

INSTALLATION

INSTALLING THE OUTDOOR KEY PAD

See Figures 58 - 60.

- Locate the following items:

Outdoor Key Pad

Screws (**need size**)

! WARNING:

Do not use garage door opener if keypads or remotes do not start and stop the motor. An opener that cannot be controlled with a keypad or remote is dangerous, can result in death or serious personal injury, and must be repaired.

! WARNING:

Make sure the key pad is mounted high enough to prevent unauthorized activation of the garage door opener. It should be placed at least 5 feet above the floor so that it is inaccessible to children. Unauthorized activation of the opener can result in death or serious personal injury.

! WARNING:

Do not start or stop the garage door opener if there is a person or object in the path of the door, the door has not been properly balanced, or if you cannot see the doorway. Failure to follow these instructions can result in death or serious personal injury.

- Find desired location outdoors and in sight of the garage door.

NOTE: The key pad should be at least 5 feet above the floor so it is inaccessible to children.

- Use a pencil to mark screw hole placement and install top screw.
- Place the wide portion of the key hole over the head of the top screw.
- Slide the keypad down until the top screw is inside the narrow portion of the key hole.
- Remove the battery cover.
- Use a level to be sure the keypad is in a vertical position, then install bottom screw into the screw hole.
- Install 9-volt battery.
- Replace battery cover.
- For programming instructions, see **Programming the Outdoor Keypad** in the *Operations* section.

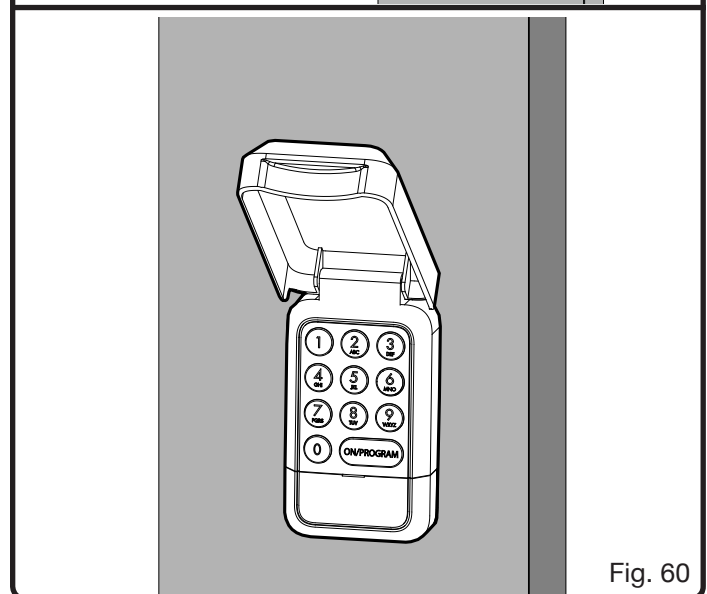
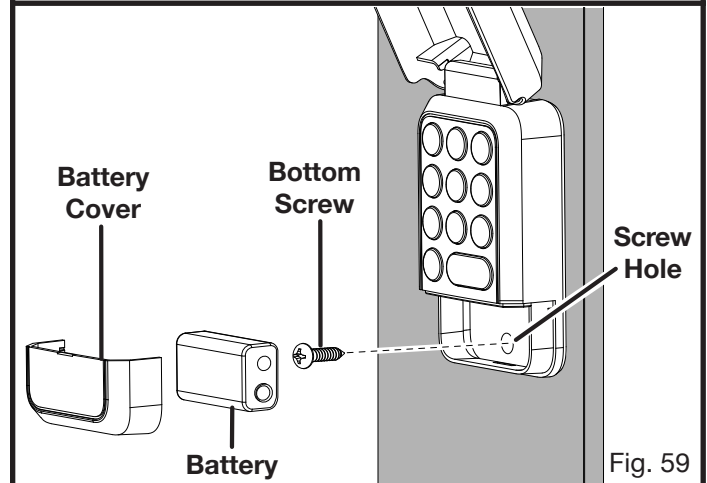
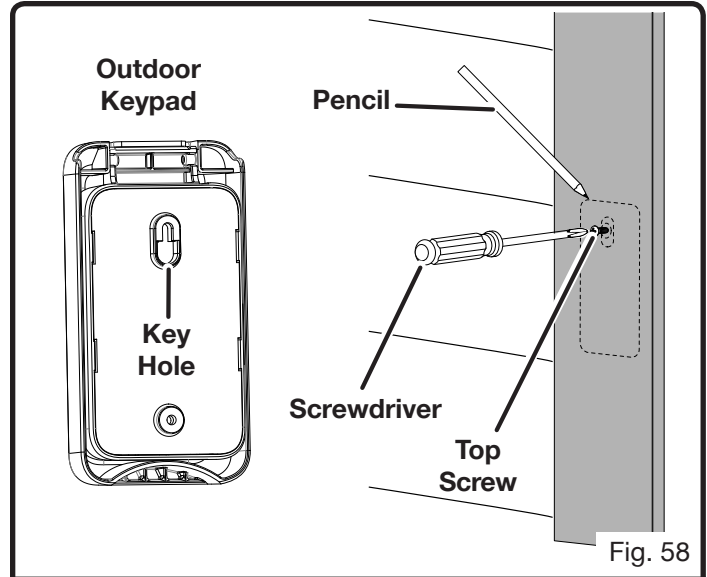

OPERATION

WARNING:

Do not allow familiarity with products to make you careless. Remember that a careless fraction of a second is sufficient to cause death or serious injury.

WARNING:

Do not use any attachments or accessories not recommended by the manufacturer of this product. The use of attachments or accessories not recommended can result in serious death or personal injury.

NOTICE:

Before each use, inspect the entire product for damaged, missing, or loose parts such as screws, nuts, bolts, caps, etc. Tighten securely all fasteners and caps and do not operate this product until all missing or damaged parts are replaced. Please contact customer service or a qualified service center for assistance.

For complete charging instructions, refer to the Operator's Manuals for your Ryobi One+ battery pack and charger models.

NOTICE:

This product is designed to be powered by either a Ryobi One+ 18V battery pack (DC mode) or by electric power (AC mode). The unit will operate in AC mode whenever it is connected to an electric power source. It will switch to DC mode when an approved battery pack is installed and the unit is not connected to an AC power source.

CONNECTING THE GARAGE DOOR OPENER TO A POWER SUPPLY

See Figures 61 and 62.

For AC power:

- Assemble and mount the garage door opener as described earlier in the *Installation* section.
- Connect the garage door opener to an AC power supply.
NOTE: Make sure the power supply is normal household voltage, 120 volts, AC only, 60 Hz.
- Ensure that the power cord does not droop excessively or contact moving parts.

For DC power:

- Unplug the garage door opener.
- Open the battery door.
- Insert the battery pack into the product as shown.

- Make sure the latches on each side of the battery pack snap into place and the battery pack is secured before beginning operation.

WARNING:

Make sure the latches on the battery pack snap in place and the battery pack is fully seated and secure in the battery port before beginning operation. Failure to securely seat the battery pack could cause the battery pack to fall out, resulting in serious personal injury or property damage.

- Close the battery door.
- Open the battery door and depress the latches to remove the battery pack.

When a battery pack is installed and the power cord is plugged in, the garage door operator will begin charging the battery pack.

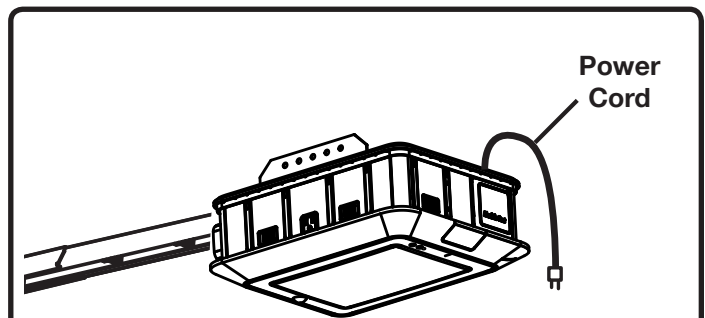

Fig. 61

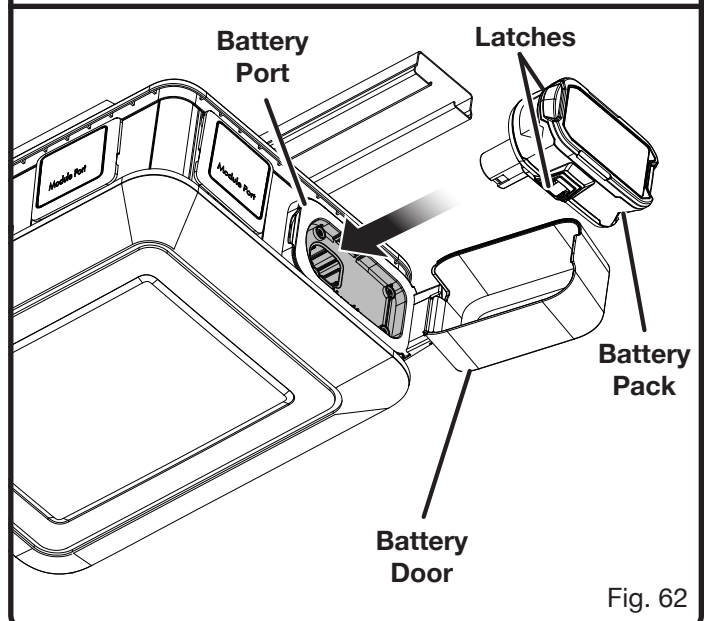

Fig. 62

OPERATION

CHARGING A BATTERY PACK

See Figure 62.

Battery packs are shipped in a low charge condition to prevent possible problems. Therefore, you should charge them before first use. If the garage door opener does not charge the battery pack under normal circumstances, return both the battery pack and garage door opener to your nearest repair center for electrical check.

- Connect the garage door opener to an AC power supply.
- Install battery pack into the garage door opener as described earlier.
- Press on the battery pack to be sure contacts on the battery pack engage properly with contacts in the garage door opener.
- The battery pack may become slightly warm to the touch while charging. This is normal and does not indicate a problem.
- When the battery pack is fully charged, remove the battery pack or leave it in the battery port to provide DC power if needed.

INSTALLING MODULES

See Figures 63 and 64.

The garage door opener can power a variety of AC and DC modules. For a complete list of modules, visit ryobitools.com/garagehub.

⚠ WARNING:

Use only recommended accessories listed on our website, in this manual, or in addendums. Use of accessories that are not listed may cause the risk of personal injury. Instructions for safe use of accessories are included with the accessory.

⚠ WARNING:

Ensure modules are properly and securely connected to their port on the garage door opener. Failure to properly secure the module can cause it to fall and could result in serious personal injury or property damage.

For DC modules:

- Select one of the seven DC module ports to power your DC module.
- Hook the module to the top of the garage door opener and insert it into the module port. Ensure the bottom latch on the module is secured to the port on the garage door opener.

NOTE: DC modules will not receive power unless the module port has been activated. See **Using the Indoor Keypad** later in this section.

- Depress latches to release and remove the module.

For AC modules:

- Remove both module port covers on the side where you will install the module.
- Insert AC module into the AC receptacle as shown.
- Secure the module in place by hooking it to the top of the garage door opener and ensure the bottom latch on the module is secured to the port on the garage door opener.
- Depress latches to release and remove the module.

NOTE: If the garage door opener is unplugged and a charged battery pack is installed, the AC receptacles and DC module ports will be disabled but the sensors and LED lights will continue to function normally.

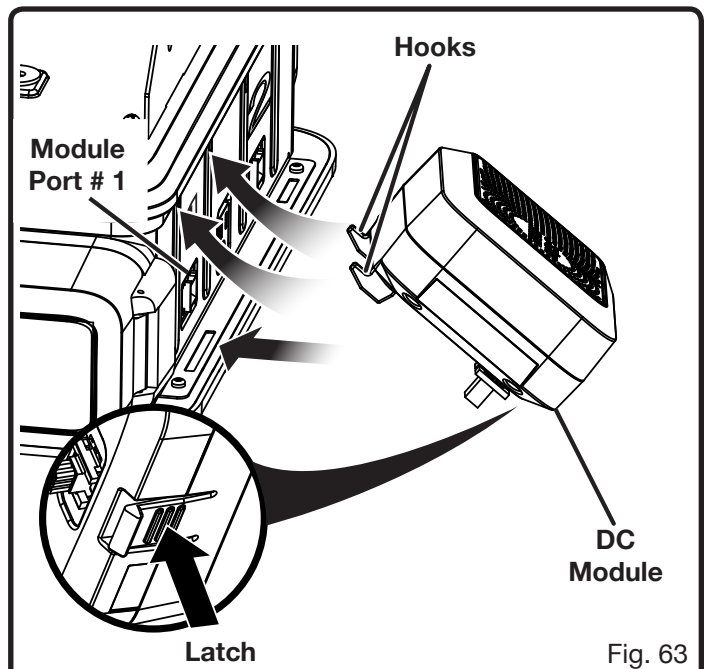

Fig. 63

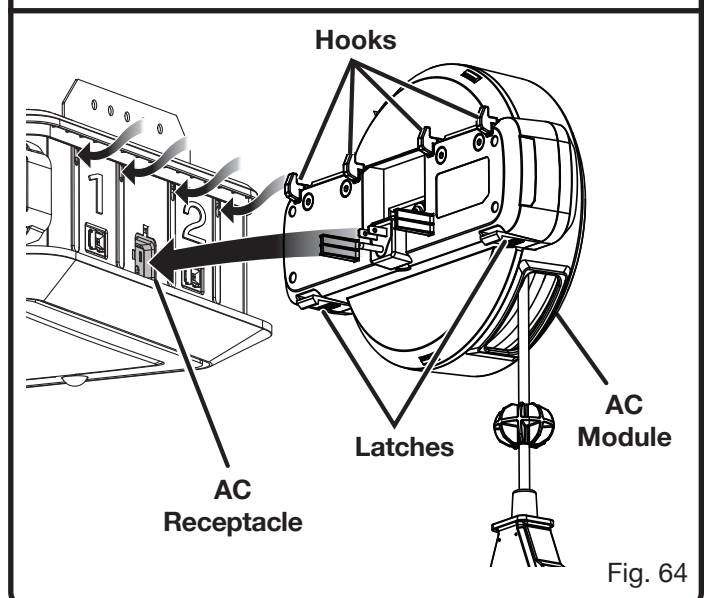

Fig. 64

OPERATION

ALIGNING THE SAFETY SENSORS

See Figure 65.

WARNING:

DO NOT operate the garage door opener unless the safety sensors are installed and working correctly. Failure to properly install and ensure that the safety sensors are working correctly can result in death or serious personal injury.

WARNING:

The effectiveness of the safety sensors included in this system directly relates to the placement and installation of the sensors. Incorrect placement or installation could prevent the sensors from working as intended and result in death or serious personal injury.

NOTICE:

The garage door will not close unless the safety sensors are installed, wired, and aligned correctly.

- Install and wire the safety sensors as described earlier in the *Installation* section.

- Connect the garage door opener to an AC power supply.
NOTE: Make sure the power supply is normal household voltage, 120 volts, AC only, 60 Hz
- If wired correctly, the LED lights on both sensors should shine continuously. **If one or both LEDs do not come on, unplug the garage door opener and ensure that the sensors are wired correctly.** If problem persists, refer to the **Safety Sensor Diagnostic Feedback** chart later in the manual.
- **If the LED lights on both sensors shine continuously, then the sensors are aligned and no adjustments are needed.**
- **If the red LED light is ON but the green LED light is off, then the sensors may need to be aligned.**
- **Loosen, but do not remove, the fasteners securing the sensors in place and adjust the position of the sensors until the lens on the transmitter and receiver are directly facing one another.**
- **When the sensor lenses are in the correct position, the invisible light beam emitted by the transmitter will be captured by the receiver and the LEDs will shine continuously.**
NOTE: If an object crosses the path of the beam, an open garage door will not close and a closing garage door should stop and reverse to the fully open position.
- **After the sensors have been aligned, retighten fasteners.**

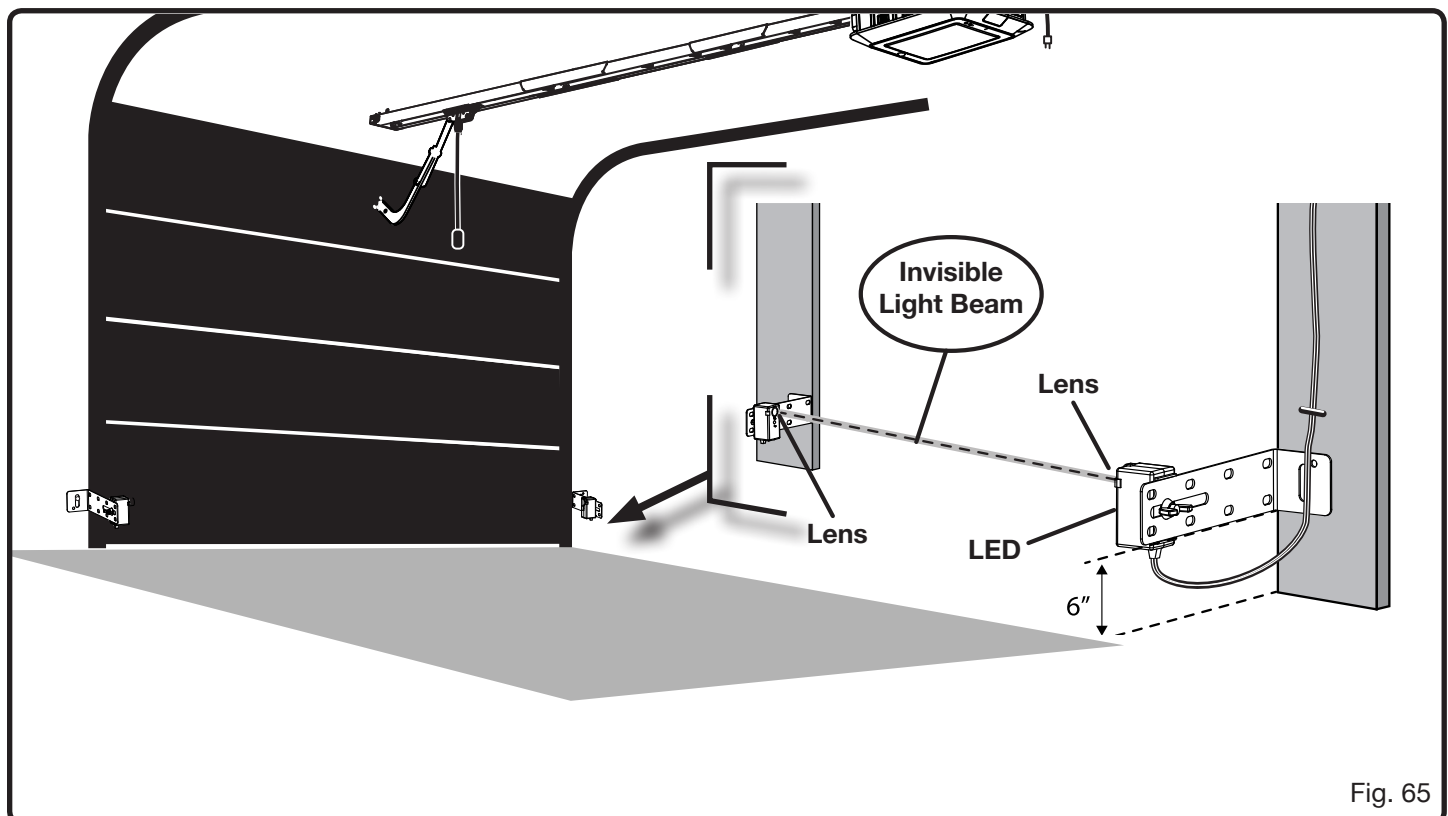

Fig. 65

OPERATION

SAFETY SENSOR DIAGNOSTIC FEEDBACK

LED FUNCTIONS			
RED LED (TRANSMITTER)	GREEN LED (RECEIVER)	PROBLEM	SOLUTION
ON	ON	No problem indicated	No action required
OFF	OFF	Garage door operator is unplugged or the battery is depleted Wires from garage door operator may be damaged Wires not connected Wires connected to the wrong terminal One or both sensors are defective	Connect to power supply or charge the battery pack Replace damaged or broken wires Connect wires to garage door operator Connect wires to the correct terminal Contact customer service or a qualified service center for assistance
OFF	ON	One or both sensors are defective	Contact customer service or a qualified service center for assistance
ON	OFF	The safety sensors are out of alignment The safety sensors are obstructed One or both sensors are defective Safety sensor (receiver) is in direct sunlight Safety sensor (transmitter) is not sending beam	Align the safety sensors Remove all objects between the safety sensors Contact customer service or a qualified service center for assistance Change the position of the sensor Contact customer service or a qualified service center for assistance

OPERATION

SETTING THE DOOR TRAVEL LIMITS

See Figures 66 - 73.

⚠ DANGER:

Ensure that the safety sensors are installed and working properly. Without the proper safety devices in place, a closing garage door could kill or seriously injure someone in its path.

The console on your garage door opener makes it easy to set the open and close positions of your door. The opener will automatically sense the weight of your door and provide the force required to open and close it.

When a garage door is fully closed, there shouldn't be any space between the door and the garage floor. When a door is fully open, it should provide enough clearance for vehicles to travel safely underneath it. Use caution when setting the open position for single-panel garage doors. If a single-panel door is opened so far that it begins to slant backwards, excessive bouncing and jerking may occur as the door moves, see figure 62.

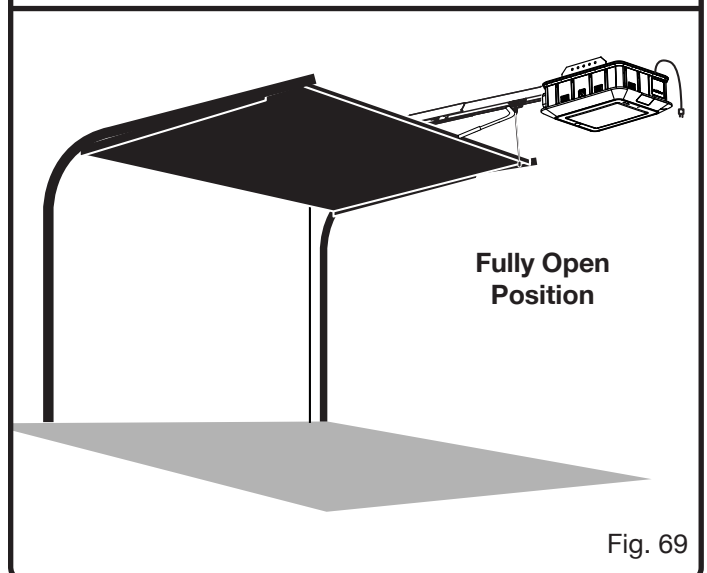
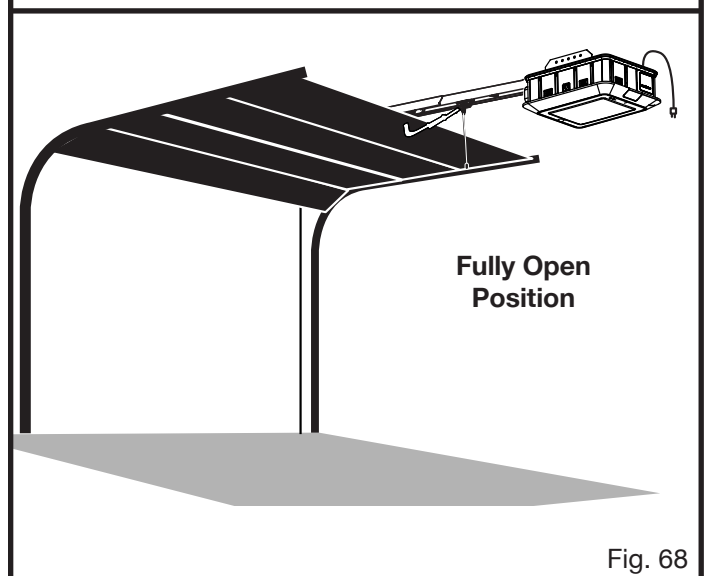
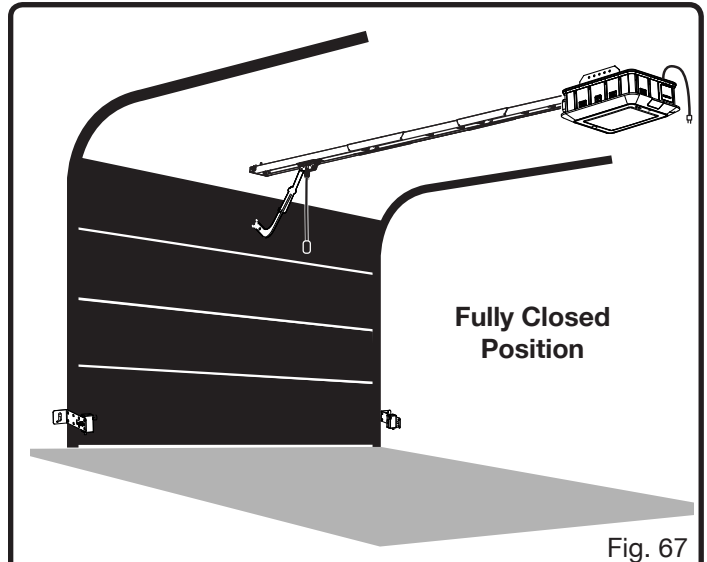
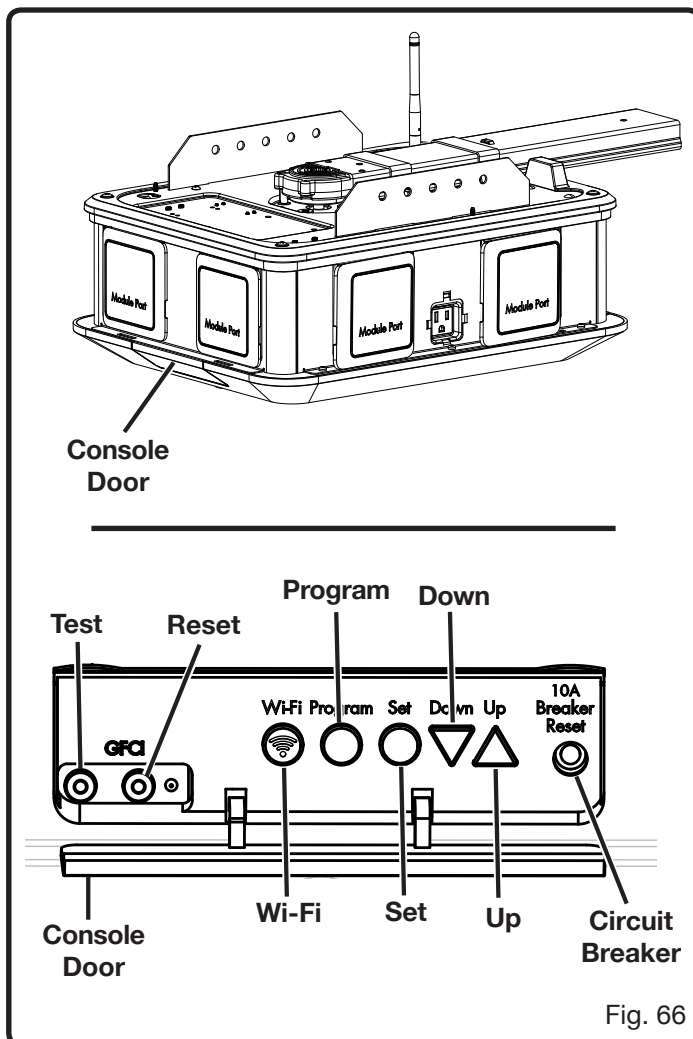

OPERATION

NOTICE:

Do not open or close the garage door using the indoor keypad or remotes until the travel limits have been properly set. Doing so could cause severe damage to the garage door or the garage door operator.

Before setting the travel limit:

- Pull the emergency release rope down and manually open the garage door until the carriage (trolley) engages the **bullet**.

To set the travel limit for the open position:

- Open the console door.
- Press and hold the **UP** button for three seconds. After you release the button, it will begin blinking and continue blinking until the travel limit has been set.
- Press and hold the **UP** button to move the garage door to the open position.
- For fine adjustments, press and release the **UP** or **DOWN** buttons.
- Once the door is in the open position, press the **SET** button to store the travel limit. Once the travel limit is stored, the **UP** button will stop blinking and shine continuously.

NOTE: If the safety sensors are obstructed during this process, travel limit information for the open and closed position will be erased.

To set the travel limit for the closed position:

- Open the console door.
- Press and hold the **DOWN** button for three seconds. After you release the button, it will begin blinking and continue blinking until the travel limit has been set.
- Press and hold the **DOWN** button to move the garage door to the closed position.
- For fine adjustments, press and release the **UP** or **DOWN** buttons.
- Once the door is in the closed position, press the **SET** button to program the travel limit. Once the travel limit is set, the **DOWN** button will stop blinking and shine continuously.

NOTE: If the safety sensors are obstructed during this process, travel limit information for the open and closed position will be erased.

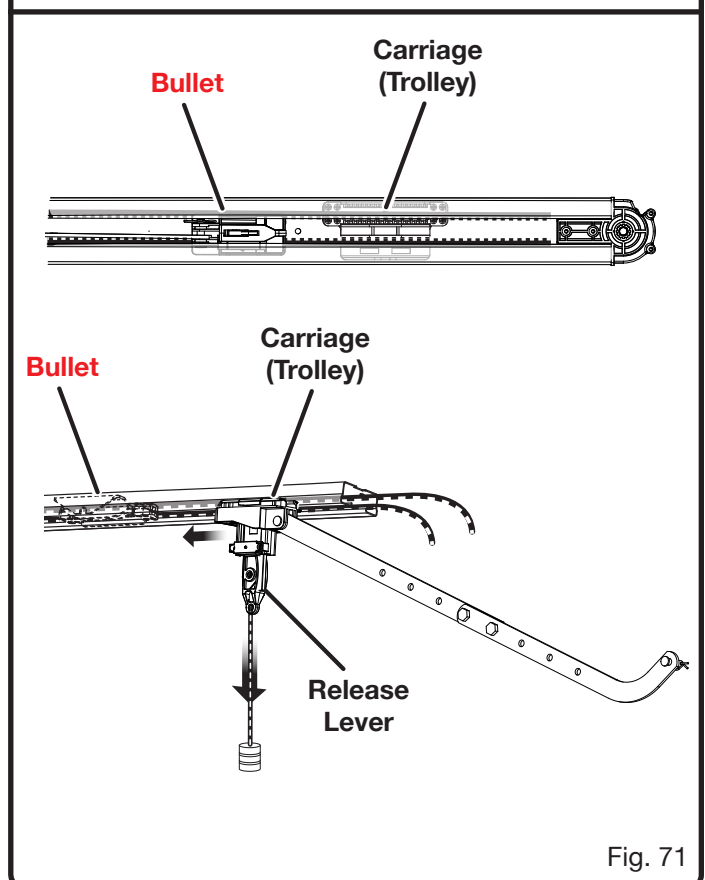
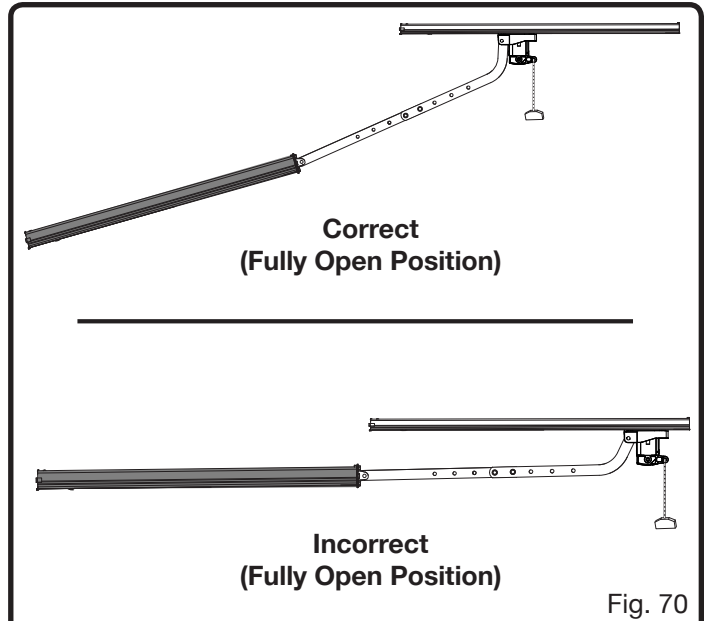

OPERATION

To test the travel limits:

NOTE: The garage door opener will not respond to the remotes or keypads until the travel limits have been tested.

- Open the console door.
- Press and release the **UP** button and ensure that the door moves to the programmed open position. The button will blink as the door moves then shine continuously once the door is in the open position.
- Press and release the **DOWN** button to ensure that the door moves to the programmed down position. The button will blink as the door moves then shine continuously once the door is in the down position.

NOTE: After testing is complete, the light for both the **UP** and **DOWN** buttons will turn off.

- If the travel limits were set incorrectly, they can be cleared by pressing and holding the **SET** button for five seconds. The **UP** and **DOWN** buttons will blink two times indicating that the unit is ready to be reprogrammed.
- If you attempt to operate the garage door opener before setting the travel limits, a buzzer will sound and the **UP** and **DOWN** buttons will blink seven times.
- If the safety sensors become misaligned or obstructed during testing, a buzzer will sound twice and the **UP** and **DOWN** buttons will blink eleven times.

NOTE: To align the sensors, refer to **Aligning The Safety Sensors** earlier in this manual.

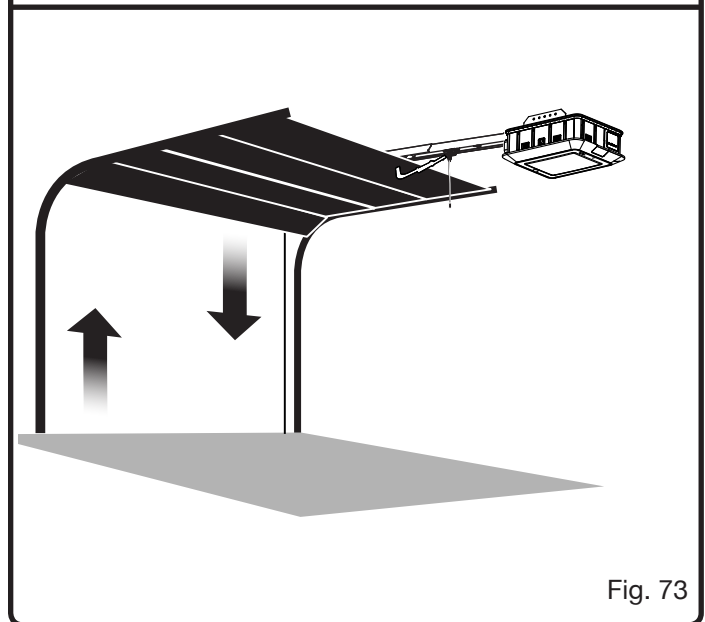
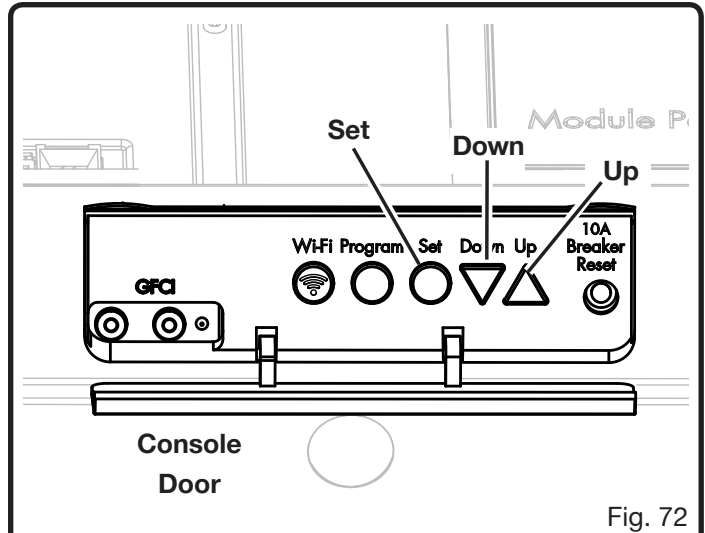

OPERATION

TESTING THE AUTOMATIC REVERSAL SYSTEM

See Figure 74.

! DANGER:

Test the automatic reversal system every month and after any adjustments are made to the garage door travel limits. If the door contacts an object higher than 1-1/2 in. off the garage floor (approx. the size of a 2x4 laid flat), it should stop and reverse to the fully open position. If the automatic reversal system does not function properly, a closing garage door could kill or seriously injure someone in its path.

! WARNING:

DO NOT operate the garage door opener unless the automatic reversal system is working correctly. Following this rule will reduce the risk of death or serious personal injury.

- Press and release the **UP** button to raise the garage door.
- Place a 1-1/2 in. board (approx. the size of a 2x4 laid flat) on the garage floor beneath the door.
- Press and release the **DOWN** button to lower the garage door. When the door strikes the board, it should reverse direction immediately.
- If the garage door reverses direction after contacting the board, the reversal system is working properly and no adjustments are needed.
- If the garage door stops before striking the board or strikes the board and then stops, increase the travel limit for the closed position and repeat the test.
- If the automatic reversal system continues to fail, contact customer service or a qualified service technician for assistance.

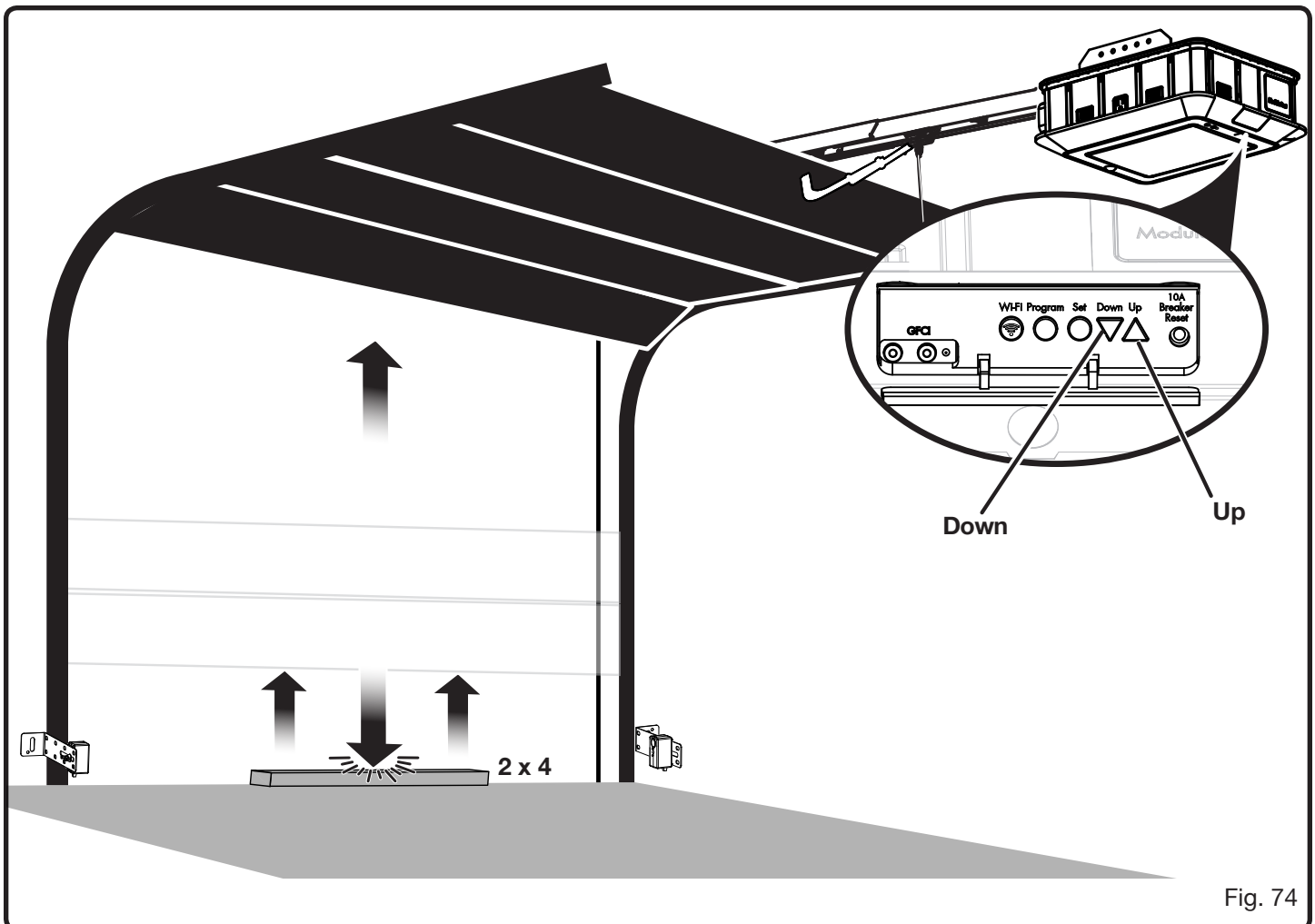

Fig. 74

OPERATION

USING THE INDOOR KEYPAD

See Figure 75.

- Install and wire the indoor keypad as described earlier in the *Installation* section.
- To raise or lower the garage door, press and release the **UP/DOWN** button.
- To lock or unlock a closed garage door, press and release the **LOCK** button. When the garage door is locked, it can only be controlled using the indoor keypad. A locked garage door cannot be opened or unlocked with a remote, outdoor keypad, or smart phone.
- To turn the LED light on and off, press and release the **LIGHT** button.

NOTE: When the light button is pressed, the LED lights will illuminate for four minutes.

Activating and Deactivating DC Module Ports:

- To activate a DC module port, press the number on the indoor keypad corresponding with the desired port. For example, **to activate module port #2 press NUMBER 2** on your keypad.

NOTE: An active module port can be used to power DC modules. Multiple ports can be activated at once.

- To deactivate a DC module port, press the number on the indoor keypad corresponding with the port.

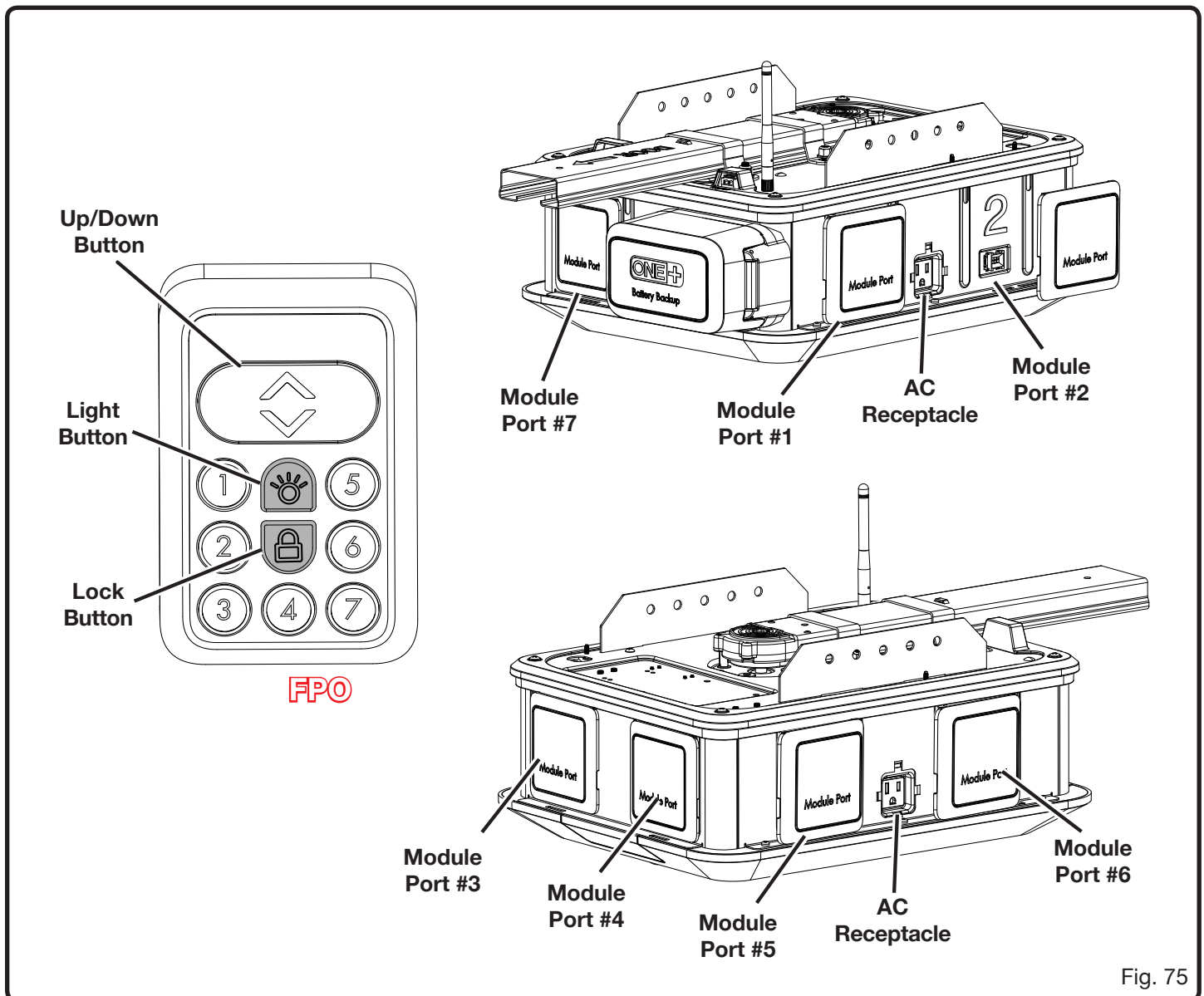

Fig. 75

OPERATION

PROGRAMMING THE OUTDOOR KEYPAD

See Figures 76 - 77.

- Install outdoor keypad and battery as described earlier in the *Installation* section.
- Open the garage door.
- Press and hold the **PROGRAM** button on the garage door opener's console until the LED lights on the bottom of the opener flash three times, indicating the console is in programming mode.
- Open the cover on the outdoor keypad and press the **ON/PROGRAM** button. The keypad will light up.
- Enter your desired PIN (4 digits), then press the **0** button and hold until the door moves.
- When the **0** button is released, the opener's LED lights should illuminate to indicate the set-up is complete.
- Once the outdoor keypad is programmed, press the **ON/PROGRAM** button and enter your PIN to open or close the garage door.

PROGRAMMING THE REMOTE CONTROLS

See Figure 78.

- Press and hold the **PROGRAM** button on the garage door opener's console until the LED lights on the bottom of the opener flash three times, indicating the console is in programming mode.
- Press and hold either button on the remote control for three seconds to sync the button to the garage door opener. The LED lights on the garage door opener will flash three times to confirm that the button and the opener are synced.

NOTE: The second button can be synced to another garage door opener.

- Repeat this process to sync the other remote.
- After the remote controls have been synced, press the left or right button on either remote control to open and close the garage door.
- Store the remotes on your car's visor using the visor clip.

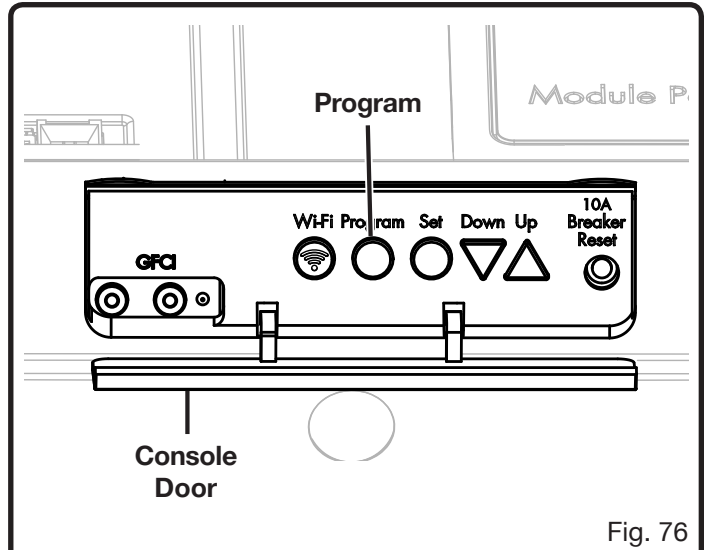

Fig. 76

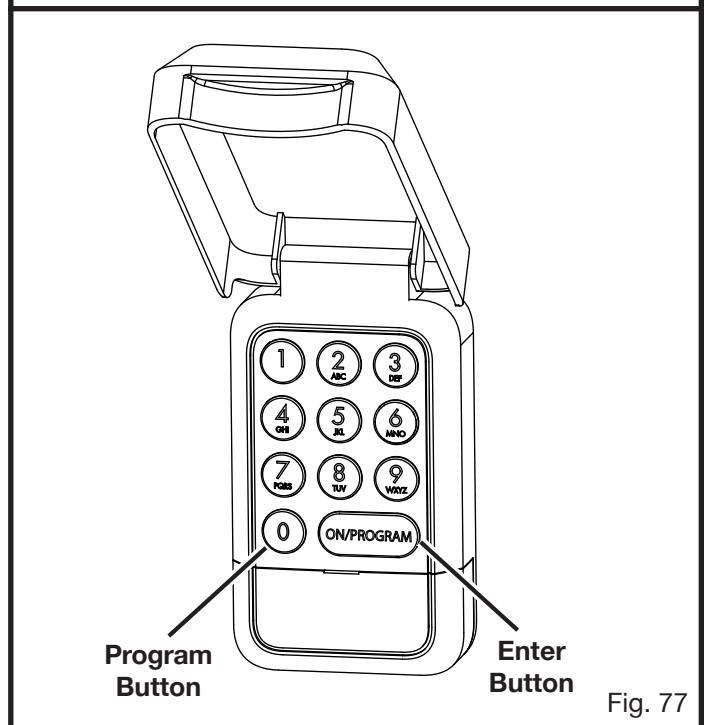

Fig. 77

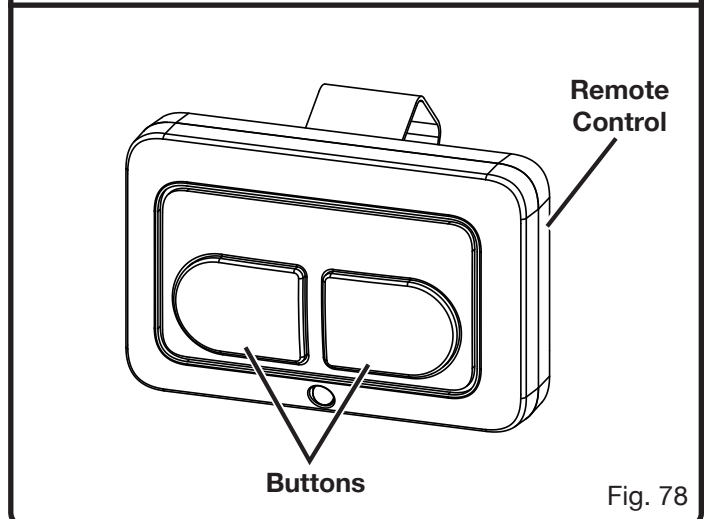

Fig. 78

OPERATION

USING THE SMARTPHONE APP

See Figure 79.



WARNING:

To reduce the risk of injury to persons – Only enable the Ryobi Garage Door Opener Module System App feature when installed with a sectional door.



WARNING:

Devices or features, such as the Ryobi Garage Door Opener Module System App, that allow you to open and close the garage without the garage door being in view should only be used with sectional garage doors.

- Download the Ryobi Garage Door Opener Module System App from the **App Store** or **Google Play Store**.
- Follow the instructions provided in the app and app guide to control your garage door opener and modules. For more information, visit www.ryobitools.com.

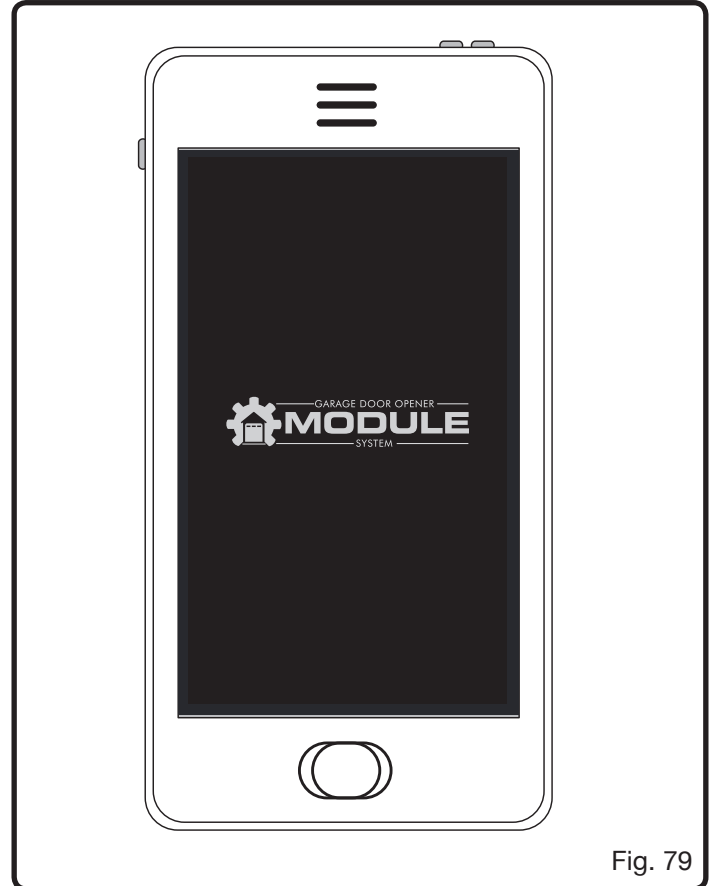

Fig. 79

MAINTENANCE

! WARNING:

Before inspecting, cleaning or servicing the machine, lower the garage door, shut off motor, wait for all moving parts to stop, disconnect unit from power supply, and remove all modules. Failure to follow these instructions can result in serious personal injury or property damage.

! WARNING:

When servicing, use only identical replacement parts. Use of any other parts could create a personal injury hazard or cause product damage.

! WARNING:

Periodically inspect the entire product for damaged, missing, or loose parts such as screws, nuts, bolts, caps, etc. Tighten securely all fasteners and caps and do not operate this product until all missing or damaged parts are replaced. Please contact customer service or a qualified service center for assistance. Loose, missing, or damaged parts can result in death, serious personal injury, or property damage.

GENERAL MAINTENANCE

Avoid using solvents when cleaning plastic parts. Most plastics are susceptible to damage from various types of commercial solvents and may be damaged by their use. Use clean cloths to remove dirt, dust, oil, grease, etc.

! WARNING:

Do not at any time let brake fluids, gasoline, petroleum-based products, penetrating oils, etc., come in contact with plastic parts. Chemicals can damage, weaken or destroy plastic which could result in serious personal injury.

POWER SUPPLY CORD REPLACEMENT

If replacement of the power supply cord is necessary, this must be done by an authorized service center in order to avoid a safety hazard.

REPLACING CAR REMOTE BATTERIES

See Figure 80.

- Remove the battery cover by inserting the edge of a coin into the slot and twisting.
- Install the battery or batteries according to the polarity indicators.

NOTE: The remote can be powered by one 2032-size battery, or two 2016-size batteries stacked together.

- Reassemble the remote by aligning the sections as shown.
- Snap the sections together to close.
- Make sure the remote is securely reassembled before attaching the visor clip.

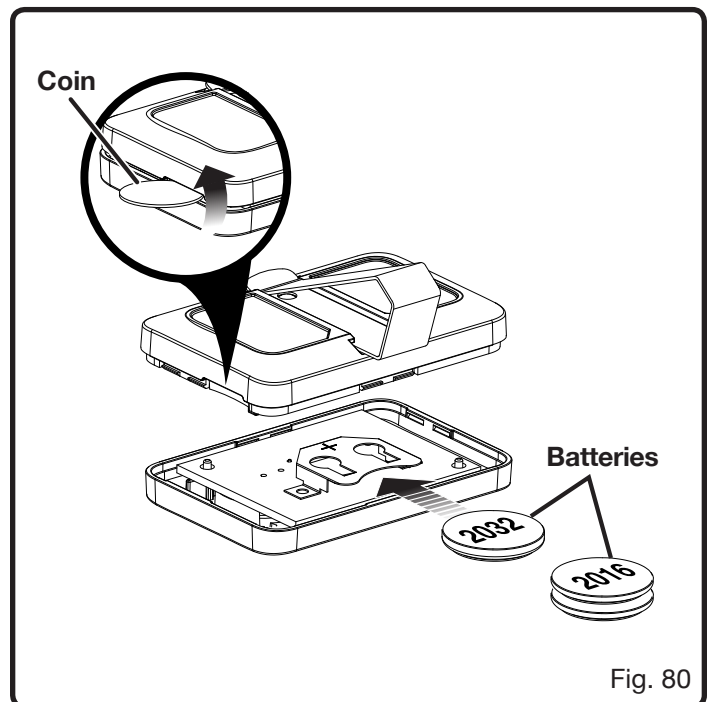

Fig. 80

MAINTENANCE

PERIODIC MAINTENANCE SCHEDULE	
Each Week	<ul style="list-style-type: none"> ■ Check the garage door operator, rail, brackets, door arms, track, and rollers for loose or damaged parts. Replace or tighten as needed.
Each Month	<ul style="list-style-type: none"> ■ Manually open and close the garage door. If the door does not move smoothly, binds, or is out of balance, have the garage door or door springs repaired by a qualified service person. ■ Test the automatic reversal system as described in the <i>Installation</i> section.
Every 3 Months	<ul style="list-style-type: none"> ■ Test the travel limits of the garage door, as described in the <i>Operation</i> section, and ensure it opens and closes fully. ■ Check the condition of the power supply cord and battery pack. Replace as needed.
Each Year	<ul style="list-style-type: none"> ■ Lubricate the garage door rollers and hinges. The garage door operator is lubricated with a sufficient amount of lubricant for the life of the unit under normal operating conditions. Therefore, no further lubrication of the operator is required. DO NOT ADD LUBRICANT TO TRACKS. ■ Unplug the garage door operator and test the battery backup. If the unit cannot run on DC power alone, charge or replace the battery pack.

ACCESSORIES

Look for these accessories where you purchased this product or call [1-877-205-5714](tel:1-877-205-5714):

- Garage Door Expander GDE50
- Bluetooth Speaker GDM120
- Dual Laser Park Assist GDM222
- Extension Cord Reel GDM330
- Security Camera GDM610
- Motion Detector GDM623
- Speed Control Fan GDM421
- Environmental Sensor GDM920
- Car Remote GDA100
- Safety Sensor GDA200
- Outdoor Keypad GDA300



WARNING:

Current attachments and accessories available for use with this product are listed above. Do not use any attachments or accessories not recommended by the manufacturer of this product. The use of attachments or accessories not recommended can result in serious personal injury.

TROUBLESHOOTING

PROBLEM	POSSIBLE CAUSE	SOLUTION
Garage door opener does not activate when indoor keypad is pressed	Battery is low in charge or power supply not connected	Charge the battery or connect to power supply
	Garage operator is locked	Press the LOCK button on the indoor keypad to unlock the operator
	The wire connecting the keypad to the operator has been damaged	Replace damaged or broken wires
Garage door operator activates, but the garage door does not move	Circuit breaker is tripped	Reset circuit breaker
	The carriage (trolley) is not engaged with the bullet	Pull the emergency release rope and raise the garage door until the carriage (trolley) engages the bullet
	The door arms are not connected to the carriage (trolley)	Secure the door arms to the carriage (trolley) using clevis and hitch pin
Garage door cannot be opened or closed with remote control, smart phone, or outdoor keypad	The door arms are not connected to the garage door	Secure the door arms to the garage door using clevis and hitch pin
	The garage door is locked	Press the LOCK button on the indoor keypad to unlock the operator
Garage door begins to close then stops and reverses	The travel limits have been set incorrectly	Adjust the travel limits as described in the <i>Operation</i> section
	The safety sensors are out of alignment	Align the safety sensors
	The safety sensors are obstructed	Remove all objects between the safety sensors
	The garage door is damaged	Check the condition of the door. If the door does not move smoothly, binds, or is out of balance, have the garage door or door springs repaired by a qualified service person.
Garage door moves downward, but stops before closing completely	The open travel limit has been set incorrectly	Adjust the travel limit as described in the <i>Operation</i> section
Garage door moves upward, but stops before opening completely	The close travel limit has been set incorrectly	Adjust the travel limit as described in the <i>Operation</i> section
Garage door operator is loud or noisy	Fasteners may not be tightened securely	Inspect the entire product for loose parts such as screws, nuts, bolts, caps, etc. Tighten all parts securely
	The open travel limit has been set incorrectly (Single Panel Doors Only)	Adjust the travel limits as described in the <i>Operation</i> section
AC modules not working	AC power supply is disconnected	Connect AC power supply
	GFCI is tripped	Press the reset button on the console

WARRANTY

LIMITED WARRANTY STATEMENT

One World Technologies, Inc., warrants to the original retail purchaser that this RYOBI™ brand garage door opener is free from defect in material and workmanship and agrees to repair or replace, at One World Technologies, Inc.'s discretion, any defective product free of charge within these time periods from the date of purchase.

Garage Door Operator/Gearbox/Rails/Door Arms

- Three year limited warranty

Motor/Belt

- Lifetime limited warranty

Sensors/Remotes/Keypads

- One year limited warranty

This warranty extends to the original retail purchaser only and commences on the date of the original retail purchase.

Any part of this product manufactured or supplied by One World Technologies, Inc., and found in the reasonable judgment of One World Technologies, Inc., to be defective in material or workmanship will be repaired or replaced without charge for parts and labor by a RYOBI™ Authorized Service Center.

The product, including any defective part, must be returned to a RYOBI™ Authorized Service Center within the warranty period. The expense of delivering the product to the service center for warranty work and the expense of returning it back to the owner after repair or replacement will be paid by the owner. One World Technologies, Inc.'s responsibility in respect to claims is limited to making the required repairs or replacements and no claim of breach of warranty shall be cause for cancellation or rescission of the contract of sale of any RYOBI™ brand product. Proof of purchase will be required to substantiate any warranty claim. All warranty work must be performed by a RYOBI™ Authorized Service Center.

This warranty does not cover any product that has been subject to misuse, neglect, negligence, or accident, or that has been operated in any way contrary to the operating instructions as specified in the operator's manual. This warranty does not apply to any damage to the product that is the result of improper maintenance or to any product that has been altered or modified so as to adversely affect the product's operation, performance or durability or that has been altered or modified so as to change its intended use. The warranty does not extend to repairs made necessary by normal wear or by the use of parts or accessories which

are either incompatible with the RYOBI™ brand garage door opener or adversely affect its operation, performance or durability.

One World Technologies, Inc., reserves the right to change or improve the design of any RYOBI™ brand garage door opener without assuming any obligation to modify any product previously manufactured.

ALL IMPLIED WARRANTIES ARE LIMITED IN DURATION TO THE STATED WARRANTY PERIOD. ACCORDINGLY, ANY SUCH IMPLIED WARRANTIES INCLUDING MERCHANTABILITY, FITNESS FOR A PARTICULAR PURPOSE, OR OTHERWISE, ARE DISCLAIMED IN THEIR ENTIRETY AFTER THE EXPIRATION OF THE STATED THREE-YEAR OR 90-DAY EXPRESS WARRANTY PERIOD. ONE WORLD TECHNOLOGIES, INC.'S OBLIGATION UNDER THIS WARRANTY IS STRICTLY AND EXCLUSIVELY LIMITED TO THE REPAIR OR REPLACEMENT OF DEFECTIVE PARTS AND ONE WORLD TECHNOLOGIES, INC., DOES NOT ASSUME OR AUTHORIZE ANYONE TO ASSUME FOR THEM ANY OTHER OBLIGATION. SOME STATES DO NOT ALLOW LIMITATIONS ON HOW LONG AN IMPLIED WARRANTY LASTS, SO THE ABOVE LIMITATION MAY NOT APPLY TO YOU. ONE WORLD TECHNOLOGIES, INC., ASSUMES NO RESPONSIBILITY FOR INCIDENTAL, CONSEQUENTIAL OR OTHER DAMAGES INCLUDING, BUT NOT LIMITED TO EXPENSE OF RETURNING THE PRODUCT TO AN AUTHORIZED RYOBI™ SERVICE CENTER AND EXPENSE OF DELIVERING IT BACK TO THE OWNER, MECHANIC'S TRAVEL TIME, TELEPHONE OR TELEGRAM CHARGES, RENTAL OF A LIKE PRODUCT DURING THE TIME WARRANTY SERVICE IS BEING PERFORMED, TRAVEL, LOSS OR DAMAGE TO PERSONAL PROPERTY, LOSS OF REVENUE, LOSS OF USE OF THE PRODUCT, LOSS OF TIME, OR INCONVENIENCE, SOME STATES DO NOT ALLOW THE EXCLUSION OR LIMITATION OF INCIDENTAL OR CONSEQUENTIAL DAMAGES, SO THE ABOVE LIMITATION OR EXCLUSION MAY NOT APPLY TO YOU.

This warranty gives you specific legal rights, and you may also have other rights which vary from state to state.

This warranty applies to all RYOBI™ brand garage door opener distributed by One World Technologies, Inc., and sold in the United States, Mexico, and Canada.

To locate your nearest RYOBI™ Authorized Service Center, dial 1-800-860-4050 or log on to our website at www.ryobitools.com.

FCC COMPLIANCE

WARNING:

Changes or modifications to this unit not expressly approved by the party responsible for compliance could void the user's authority to operate the equipment.

This device complies with part 15 of the FCC rules. Operation is subject to the following two conditions: (1) this device may not cause harmful interference, and (2) this device must accept any interference received, including interference that may cause undesired operation.

NOTE: The grantee is not responsible for any changes or modifications not expressly approved by the party responsible for compliance. Such modifications could void the user's authority to operate the equipment.

NOTE: This equipment has been tested and found to comply with the limits for a Class B digital device, pursuant to part 15 of the FCC Rules. These limits are designed to provide reasonable protection against harmful interference in a residential installation. This equipment generates, uses and can radiate radio frequency energy and, if not installed and used in accordance with the instructions, may cause harmful interference to radio communications. However, there is no guarantee that interference will not occur in a particular installation. If this equipment does cause harmful interference to radio or television reception, which can be determined by turning the equipment off and on, the user is encouraged to try to correct the interference by one or more of the following measures:

- Reorient or relocate the receiving antenna.
- Increase the separation between the equipment and receiver.
- Connect the equipment into an outlet on a circuit different from that to which the receiver is connected.
- Consult the dealer or an experienced radio/TV technician for help.

This device complies with Industry Canada license-exempt RSS standard(s). Operation is subject to the following two conditions: (1) this device may not cause interference, and (2) this device must accept any interference, including interference that may cause undesired operation of the device.

Under Industry Canada regulations, this radio transmitter may only operate using an antenna of a type and maximum (or lesser) gain approved for the transmitter by Industry Canada. To reduce potential radio interference to other users, the antenna type and its gain should be so chosen that the equivalent isotropically radiated power (e.i.r.p.) is not more than that necessary for successful communication.

The applicant is responsible for providing proper instructions to the user of the radio device, and any usage restrictions, including limits of exposure durations. The user manual shall provide installation and operation instructions, as well as any special usage conditions, to ensure compliance with SAR and/or RF field strength limits. For instance, compliance distance shall be clearly stated in the user manual.

The user manual of devices intended for controlled use shall also include information relating to the operating characteristics of the device; the operating instructions to ensure compliance with SAR and/or RF field strength limits; information on the installation and operation of accessories to ensure compliance with SAR and/or RF field strength limits; and contact information where the user can obtain Canadian information on RF exposure and compliance. Other related information may also be included.



OPERATOR'S MANUAL / GARAGE DOOR OPENER
MANUEL D'UTILISATION / GARAGE DOOR OPENER
MANUAL DEL OPERADOR / GARAGE DOOR OPENER
GD200

To request service, purchase replacement parts,
locate an Authorized Service Center and obtain Customer or Technical Support:

Visit **www.ryobitools.com** or call **1-877-205-5714**

If any parts or accessories are damaged or missing,
do not return this product to the store. Call **1-877-205-5714** for immediate service.

Please obtain your model and serial number from the product data plate.

MODEL NUMBER _____ SERIAL NUMBER _____

RYOBI is a registered trademark of Ryobi Limited and is used pursuant to a license granted by Ryobi Limited.

Pour faire une demande de réparations ou obtenir des pièces de rechange, trouver un
Centre de réparations agréé pour obtenir un soutien technique ou le Service à la clientèle :

Visiter **www.ryobitools.com** ou en téléphonant au **1-877-205-5714**

Si des pièces ou accessoires sont manquantes ou endommagées, ne pas retourner
ce produit au magasin. Appeler immédiatement au **1-877-205-5714** pour obtenir de l'aide.

Inscrire les numéros de modèle et de série inscrits sur la plaque d'identification du produit.

NUMÉRO DE MODÈLE _____ NUMÉRO DE SÉRIE _____

RYOBI est une marque déposée de Ryobi Limited et est utilisée en vertu d'une licence accordée par Ryobi Limited.

Para obtener servicio, comprar piezas de repuesto, localizar un centro de servicio autorizado
y obtener Servicio o Asistencia Técnica al Consumidor:

Visite **www.ryobitools.com** o llame al **1-877-205-5714**

Si hay alguna pieza ou accesorios dañada o faltante, no devuelva este producto a la tienda.
Llame al **1-877-205-5714** para servicio técnico inmediato.

Obtenga su modelo y número de serie de la placa de datos del producto.

NÚMERO DE MODELO _____ NÚMERO DE SERIE _____

RYOBI es una marca registrada de Ryobi Limited y se utiliza conforme a una licencia otorgada por Ryobi Limited.

ONE WORLD TECHNOLOGIES, INC.

1428 Pearman Dairy Road, Anderson, SC 29625 • Phone **1-877-205-5714**
États-Unis, Téléphone **1-877-205-5714** • USA, Teléfono **1-877-205-5714**

www.ryobitools.com