

iDECT X3 Twin Label for Warlmart order

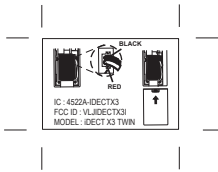

' iDECT X3 series '

- Details: handset batteries label for battery compartment
- 1) one colour: red, pantone 485c on white background
 - 2) material: adhesive label with plastic lamination on top
 - 3) Size: 18L*12W mm, scale 1:1 fit on battery compartment



' iDECT X3 Twin '

- Rating label on Base Unit back
- 1) Black background White letters
 - 2) Material: label paper with plastic lamination on top
 - 3) Size: 35L*29W MM, Fit on unit back

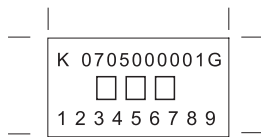

Date code and serial no.
label for base unit -back

' iDECT X3 series '

Date code and service no. label on base unit back
and handset battery compartment

Your factory code is 'K'

07 = Year (2007) _____ Produce date "G" for RoHS
05 = Month (May.)

Serial no. start from '000001' (6 digits)

= 3 check boxes for Binatone inspection purpose.

1 > 9 for version number

white background black letters
size: fit on unit back

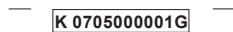

Date code and serial no.
label for cordless
handset-battery compartment

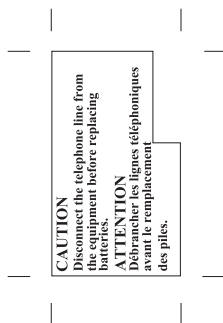

' iDECT X3 series '

Details: handset batteries label for battery compartment

- 1) one colour: white
- 2) material: label paper
- 3) scale: 1:1 fit on battery compartment

' iDECT X3 Twin '

Rear of the Base Unit

- 1) Whitebackground Black letters
- 2) Material: label paper with plastic lamination on top
- 3) Size: Fit on unit back

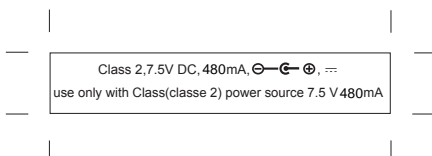

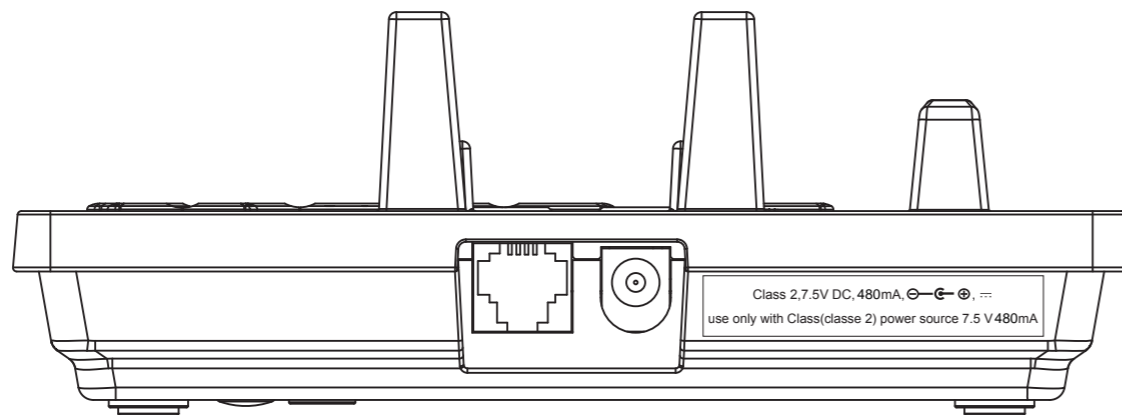
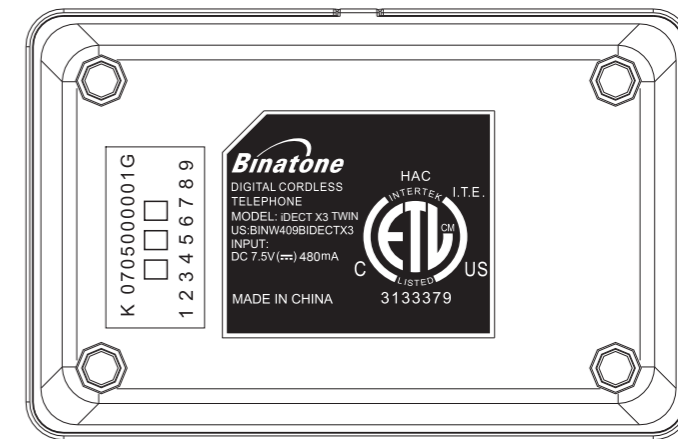
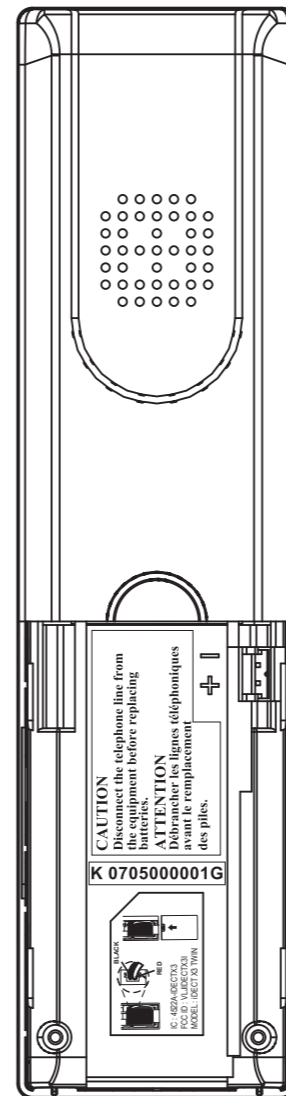
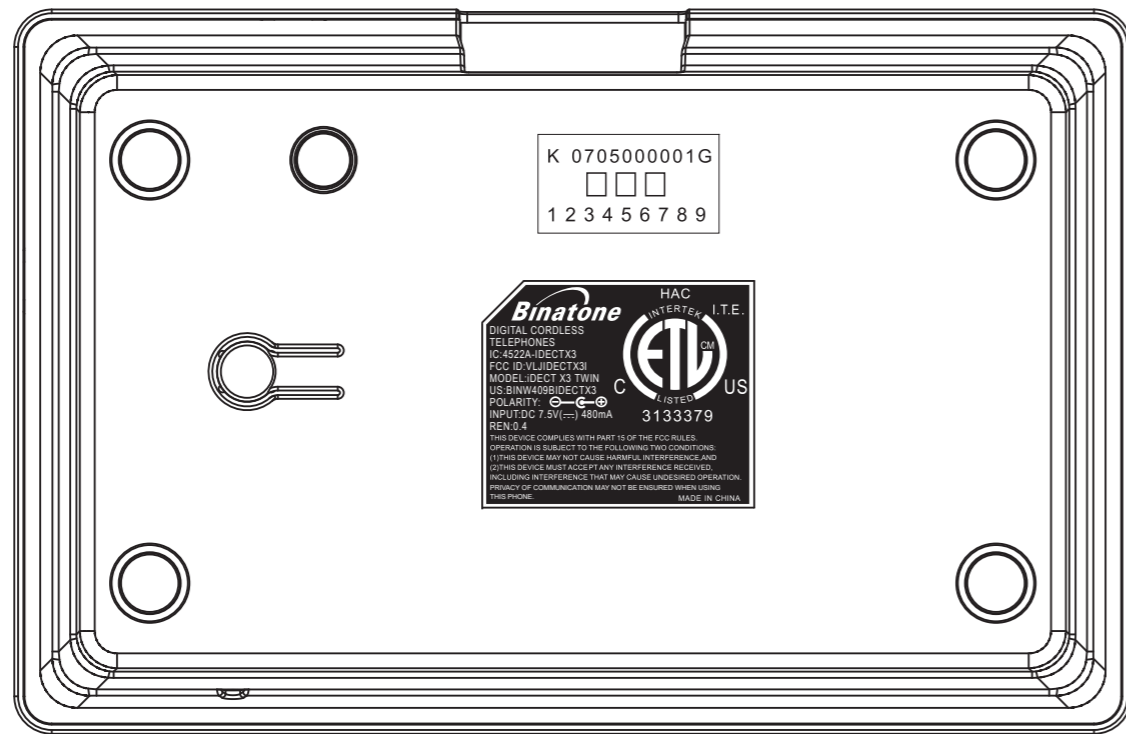

iDECT X3i Twin Label for Canada Walmart order

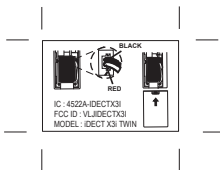

' iDECT X3i series '

- Details: handset batteries label for battery compartment
- 1) one colour: red, pantone 485c on white background
 - 2) material: adhesive label with plastic lamination on top
 - 3) Size: 18L*12W mm, scale 1:1 fit on battery compartment



' iDECT X3i Twin '

- Rating label on Base Unit back
- 1) Black background White letters
 - 2) Material: label paper with plastic lamination on top
 - 3) Size: 35L*29W MM, Fit on unit back

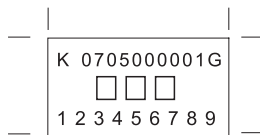

Date code and serial no.
label for base unit -back

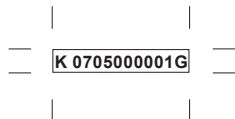

Date code and serial no.
label for cordless
handset-battery compartment

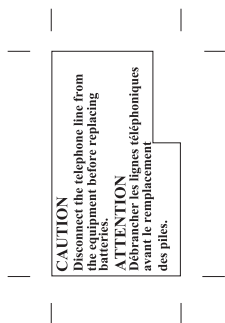

' iDECT X3i series '

- Details: handset batteries label for battery compartment
- 1) one colour: white
 - 2) material: label paper
 - 3) scale: 1:1 fit on battery compartment

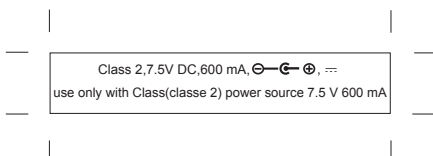

' iDECT X3i Twin '

- Rear of the Base Unit
- 1) Whitebackground Black letters
 - 2) Material: label paper with plastic lamination on top
 - 3) Size: Fit on unit back

