

Test Report

FCC Part15 Subpart C

Product Name : Verve Ones/Verve Ones+
Model No. : SH001
FCC ID : VLJ-SH001
IC : 4522A-SH001

Applicant : Binatone Electronics International Limited
Address : Floor 23A, 9 Des Voeux Road West, Sheung
Wan, Hong Kong

Date of Receipt : Dec. 30, 2015
Test Date : Jan. 06, 2016~ Jan. 19, 2016
Issued Date : Mar. 02, 2016
Report No. : 15C2093R-RF-US-P06V01
Report Version : V 1.1

The test results relate only to the samples tested.

The test results shown in the test report are traceable to the national/international standard through the calibration of the equipment and evaluated measurement uncertainty herein.

This report must not be used to claim product endorsement by TAF, CNAS or any agency of the government.

The test report shall not be reproduced without the written approval of QuieTek Corporation.

Test Report Certification

Issued Date :. Mar. 02, 2016

Report No. : 15C2093R-RF-US-P06V01



Product Name : Verve Ones/Verve Ones+
Applicant : Binatone Electronics International Limited
Address : Floor 23A, 9 Des Voeux Road West, Sheung Wan, Hong Kong
Manufacturer : Weifang GoerTek Electronics Co.,Ltd
Address : Gaoxin 2 Road, Free Trade Zone, Weifang, Shandong,
261205, P.R.China
Model No. : SH001
FCC ID : VLJ-SH001
IC : 4522A-SH001
EUT Voltage : DC 3.7V
Brand Name : Motorola
Applicable Standard : FCC CFR Title 47 Part 15 Subpart C: 2014
ANSI C63.4: 2014; ANSI C63.10: 2013
Industry Canada RSS-Gen Issue 4/RSS-247 Issue 1
Test Result : Complied
Performed Location : Suzhou EMC Laboratory
No.99 Hongye Rd., Suzhou Industrial Park, Suzhou, 215006,
Jiangsu, China
TEL: +86-512-6251-5088 / FAX: +86-512-6251-5098
FCC Registration Number: 800392; IC Lab Code: 4075B

Documented By : Alice Ni
(Senior Engineering Adm. Specialist: Alice Ni)

Reviewed By : Jack Zhang
(Senior Engineer: Jack Zhang)

Approved By : Harry Zhao
(Engineering Manager : Harry Zhao)

Laboratory Information

We, **Quietek Corporation**, are an independent EMC and safety consultancy that was established the whole facility in our laboratories. The test facility has been accredited/accepted(audited or listed) by the following related bodies in compliance with ISO 17025, EN 45001 and specified testing scope:

Taiwan R.O.C.	:	BSMI, NCC, TAF
USA	:	FCC
Japan	:	VCCI
China	:	CNAS

The related certificate for our laboratories about the test site and management system can be downloaded from Quietek Corporation's Web Site : <http://www.quietek.com/english/about/certificates.aspx?bval=5>
The address and introduction of Quietek Corporation's laboratories can be founded in our Web site : http://www.quietek.com/index_en.aspx
If you have any comments, Please don't hesitate to contact us. Our contact information is as below:

HsinChu Testing Laboratory :

No.75-2, 3rd Lin, Wangye Keng, Yonghxing Tsuen, Qionglin Shiang, Hsinchu County 307, Taiwan, R.O.C.
TEL:+886-3-592-8858 / FAX:+886-3-592-8859 E-Mail : service@quietek.com

LinKou Testing Laboratory :

No.5-22, Ruishukeng, Linkou Dist., New Taipei City 24451, Taiwan, R.O.C.
TEL : 886-2-8601-3788 / FAX : 886-2-8601-3789 E-Mail : service@quietek.com

Suzhou Testing Laboratory :

No.99 Hongye Rd., Suzhou Industrial Park, Suzhou, 215006, Jiangsu, China
TEL : +86-512-6251-5088 / FAX : 86-512-6251-5098 E-Mail : service@quietek.com

TABLE OF CONTENTS

Description	Page
1. General Information.....	8
1.1. EUT Description	8
1.2. Mode of Operation	10
1.3. Tested System Details.....	11
1.4. Configuration of Tested System	12
1.5. EUT Exercise Software	13
2. Technical Test.....	14
2.1. Summary of Test Result	14
2.2. Test Environment	16
3. Conducted Emission	17
3.1. Test Equipment	17
3.2. Test Setup	17
3.3. Limit.....	18
3.4. Test Procedure	18
3.5. Uncertainty	18
3.6. Test Result	19
4. Radiated Emission	21
4.1. Test Equipment	21
4.2. Test Setup	22
4.3. Limit.....	23
4.4. Test Procedure	23
4.5. Uncertainty	25
4.6. Test Result	26
5. 20dB Bandwidth	31
5.1. Test Equipment	31
5.2. Test Setup	31
5.3. Limit.....	31
5.4. Test Procedure	32
5.5. Uncertainty	32
5.6. Test Result	33
6. Carrier Frequency Separation	39
6.1. Test Equipment	39
6.2. Test Setup	39
6.3. Limit.....	39
6.4. Test Procedure	40
6.5. Uncertainty	40
6.6. Test Result	41

7.	Number of Hopping Frequencies	47
7.1.	Test Equipment	47
7.2.	Test Setup	47
7.3.	Limit.....	47
7.4.	Test Procedure	48
7.5.	Uncertainty	48
7.6.	Test Result	49
8.	Time of Occupancy (Dwell Time).....	55
8.1.	Test Equipment	55
8.2.	Test Setup	55
8.3.	Limit.....	55
8.4.	Test Procedure	56
8.5.	Uncertainty	56
8.6.	Test Result	57
9.	Peak Output Power	63
9.1.	Test Equipment	63
9.2.	Test Setup	63
9.3.	Limit.....	63
9.4.	Test Procedure	64
9.5.	Uncertainty	64
9.6.	Test Result	65
10.	Band-edge Compliance of RF Conducted Emissions	71
10.1.	Test Equipment	71
10.2.	Test Setup	71
10.3.	Limit.....	71
10.4.	Test Procedure	72
10.5.	Uncertainty	72
10.6.	Test Result	73
11.	Spurious RF Conducted Emissions.....	77
11.1.	Test Equipment	77
11.2.	Test Setup	77
11.3.	Limit.....	77
11.4.	Test Procedure	78
11.5.	Uncertainty	78
11.6.	Test Result	79
12.	Radiated Emission Band Edge.....	82
12.1.	Test Equipment	82
12.2.	Test Setup	83

12.3. Limit..... 83
12.4. Test Procedure 83
12.5. Uncertainty 84
12.6. Test Result 85

History of This Test Report

REPORT NO.	VERSION	DESCRIPTION	ISSUED DATE
15C2093R-RF-US-P06V01	V1.0	Initial Issued Report	Feb. 16, 2016
15C2093R-RF-US-P06V01	V1.1	(1) On page 65, update the power data (2) On page 79, update the Conducted Emissions data	Mar. 02, 2016

1. General Information

1.1. EUT Description

Product Name	Verve Ones/Verve Ones+
Model No.	SH001
Working Voltage	DC 3.7V
Bluetooth Specification	V3.0+V4.1
Frequency Range	2402- 2480 MHz
Channel Number	V3.0: 79
Channel Separation	V3.0: 1MHz
Type of Modulation	V3.0: GFSK, Pi/4 DQPSK, 8DPSK
Data Rate	V3.0: 1Mbps(GFSK), 2Mbps(Pi/4 DQPSK), 3Mbps (8DPSK)
Antenna Type	Reference to Antenna List
Peak Antenna Gain	Reference to Antenna List

Note: The EUT is not supporting BLE.

Bluetooth Working Frequency of Each Channel: (For V3.0)							
Channel	Frequency	Channel	Frequency	Channel	Frequency	Channel	Frequency
00	2402 MHz	01	2403 MHz	02	2404 MHz	03	2405 MHz
04	2406 MHz	05	2407 MHz	06	2408 MHz	07	2409 MHz
08	2410 MHz	09	2411 MHz	10	2412 MHz	11	2413 MHz
12	2414 MHz	13	2415 MHz	14	2416 MHz	15	2417 MHz
16	2418 MHz	17	2419 MHz	18	2420 MHz	19	2421 MHz
20	2422 MHz	21	2423 MHz	22	2424 MHz	23	2425 MHz
24	2426 MHz	25	2427 MHz	26	2428 MHz	27	2429 MHz
28	2430 MHz	29	2431 MHz	30	2432 MHz	31	2433 MHz
32	2434 MHz	33	2435 MHz	34	2436 MHz	35	2437 MHz
36	2438 MHz	37	2439 MHz	38	2440 MHz	39	2441 MHz
40	2442 MHz	41	2443 MHz	42	2444 MHz	43	2445 MHz
44	2446 MHz	45	2447 MHz	46	2448 MHz	47	2449 MHz
48	2450 MHz	49	2451 MHz	50	2452 MHz	51	2453 MHz
52	2454 MHz	53	2455 MHz	54	2456 MHz	55	2457 MHz
56	2458 MHz	57	2459 MHz	58	2460 MHz	59	2461 MHz
60	2462 MHz	61	2463 MHz	62	2464 MHz	63	2465 MHz
64	2466 MHz	65	2467 MHz	66	2468 MHz	67	2469 MHz
68	2470 MHz	69	2471 MHz	70	2472 MHz	71	2473 MHz
72	2474 MHz	73	2475 MHz	74	2476 MHz	75	2477 MHz
76	2478 MHz	77	2479 MHz	78	2480 MHz	N/A	N/A

Bluetooth Antenna List

Antenna	Manufacturer	Model No.	Peak Gain
Stamping antenna	Goertek	N/A	1.71dBi for 2.4GHz

1.2 Mode of Operation

QuieTek has verified the construction and function in typical operation. All the test modes were carried out with the EUT in normal operation, which was shown in this test report and defined as:

Test Mode
Mode 1: Transmitter-1Mbps(GFSK_DH5)
Mode 2: Transmitter-2Mbps(Pi/4 DQPSK_DH5)
Mode 3: Transmitter-3Mbps(8DPSK_DH5)

Note:

1. For portable device, radiated spurious emission was verified over X, Y, Z Axis, and shown the worst case on this report.
2. Regards to the frequency band operation for systems using FHSS modulation: normal operation (hopping) was selected to test for conducted, and the lowest, highest frequency channel for radiation spurious test.
3. The extreme test condition for voltage and temperature were declared by the manufacturer.
4. The reading values of all the test items contain cable loss.

1.3 Tested System Details

The types for all equipments, plus descriptions of all cables used in the tested system (including inserted cards) are:

Product	Manufacturer	Model No.	Serial No.	Power Cord
1 Notebook	Think Pad	2526	LV-A3285	Power by adapter

1.4 Configuration of Tested System

Connection Diagram(Conducted Emission)

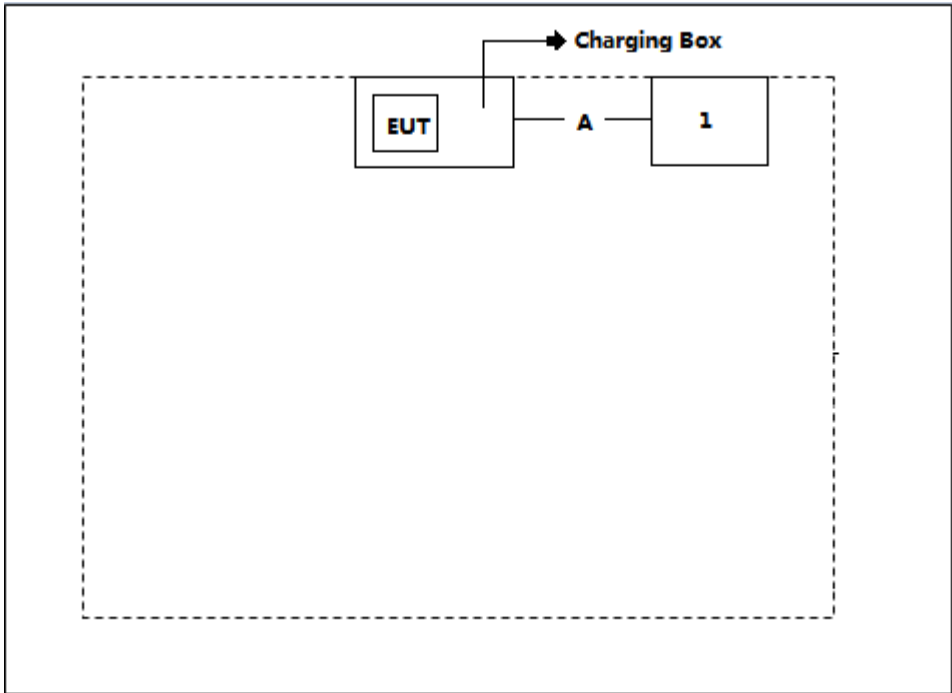

Connection Diagram(Radiated Emission)

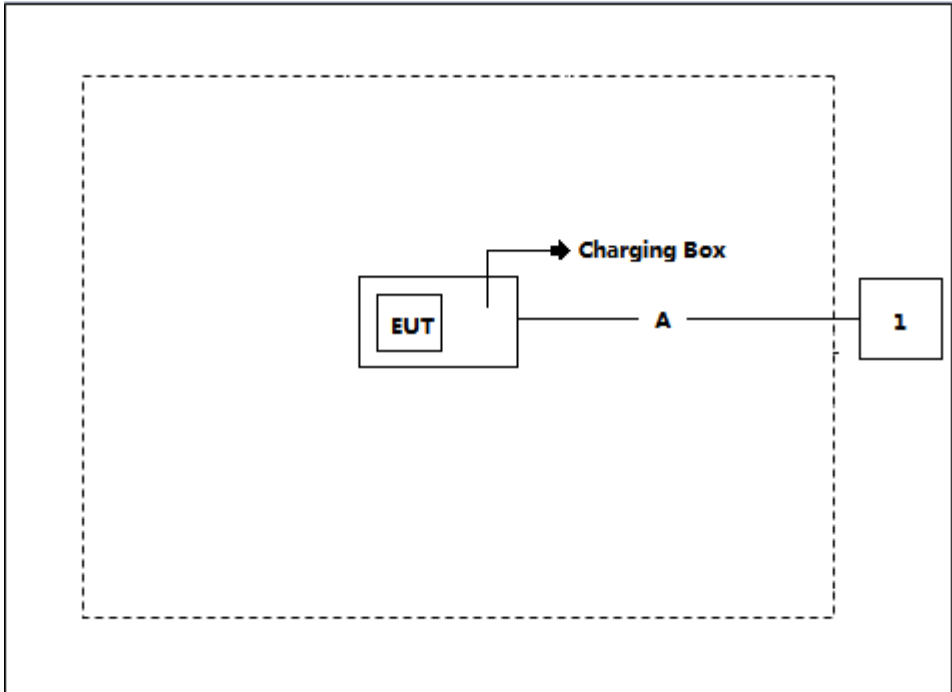

Signal Cable Type		Signal cable Description
A	USB Control Cable	Shielded, 70cm

1.5 EUT Exercise Software

1	Setup the EUT and simulators as shown on above.
2	Turn on the power of all equipment.
3	Run the RF test software, and set the test mode and channel, then press OK to start continue Transmit.

2. Technical Test

2.1. Summary of Test Result

- No deviations from the test standards
- Deviations from the test standards as below description:

For FCC

Performed Test Item	Normative References	Test Performed	Deviation
Conducted Emission	FCC CFR Title 47 Part 15 Subpart C: 2014 Section 15.207	Yes	No
Radiated Emission	FCC CFR Title 47 Part 15 Subpart C: 2014 Section 15.209	Yes	No
20dB Bandwidth	FCC CFR Title 47 Part 15 Subpart C: 2014 Section 15.247(a)(1)	Yes	No
Carrier Frequency Separation	FCC CFR Title 47 Part 15 Subpart C: 2014 Section 15.247(a)(1)	Yes	No
Number of Hopping Frequencies	FCC CFR Title 47 Part 15 Subpart C: 2014 Section 15.247(a)(1)(iii)	Yes	No
Time of Occupancy (Dwell Time)	FCC CFR Title 47 Part 15 Subpart C: 2014 Section 15.247(a)(1)(iii)	Yes	No
Peak Output Power	FCC CFR Title 47 Part 15 Subpart C: 2014 Section 15.247(b)(1)	Yes	No
Band-edge Compliance of RF Conducted Emissions	FCC CFR Title 47 Part 15 Subpart C: 2014 Section 15.215(c), 15.247(d)	Yes	No
Spurious RF Conducted Emissions	FCC CFR Title 47 Part 15 Subpart C: 2014 15.247(d)	Yes	No
Radiated Emission Band Edge	FCC CFR Title 47 Part 15 Subpart C: 2014 15.247(d)	Yes	No

For IC

Performed Test Item	Normative References	Test Performed	Deviation
Conducted Emission	RSS-Gen Issue 4 Section 8.8	Yes	No
Radiated Emission	RSS-Gen Issue 4 Section 8.9	Yes	No
20dB Bandwidth	RSS-247 Issue 1 Section 5.1	Yes	No
Carrier Frequency Separation	RSS-247 Issue 1 Section 5.1	Yes	No
Number of Hopping Frequencies	RSS-247 Issue 1 Section 5.1	Yes	No
Time of Occupancy (Dwell Time)	RSS-247 Issue 1 Section 5.1	Yes	No
Peak Output Power	RSS-247 Issue 1 Section 5.4	Yes	No
Band-edge Compliance of RF Conducted Emissions	RSS-247 Issue 1 Section 5.5	Yes	No
Spurious RF Conducted Emissions	RSS-247 Issue 1 Section 5.5	Yes	No
Radiated Emission Band Edge	RSS-Gen Issue 4 Section 8.10	Yes	No

2.2. Test Environment

Items	Required (IEC 68-1)	Actual
Temperature (°C)	15-35	21
Humidity (%RH)	25-75	50
Barometric pressure (mbar)	860-1060	950-1000

3. Conducted Emission

3.1. Test Equipment

Conducted Emission / TR-1

Instrument	Manufacturer	Type No.	Serial No.	Cal. Due Date
EMI Test Receiver	R&S	ESCI	100726	2016.03.10
Two-Line V-Network	R&S	ENV216	100043	2016.03.10
Two-Line V-Network	R&S	ENV216	100044	2016.09.16
50ohm Coaxial Switch	Anritsu	MP59B	6200464462	2016.03.01
50ohm Termination	SHX	TF2	07081401	2016.09.16
Temperature/Humidity Meter	zhicheng	ZC1-2	TR1-TH	2017.01.07

Note: All equipments are calibrated with traceable calibrations. Each calibration is traceable to the national or international standards.

3.2. Test Setup

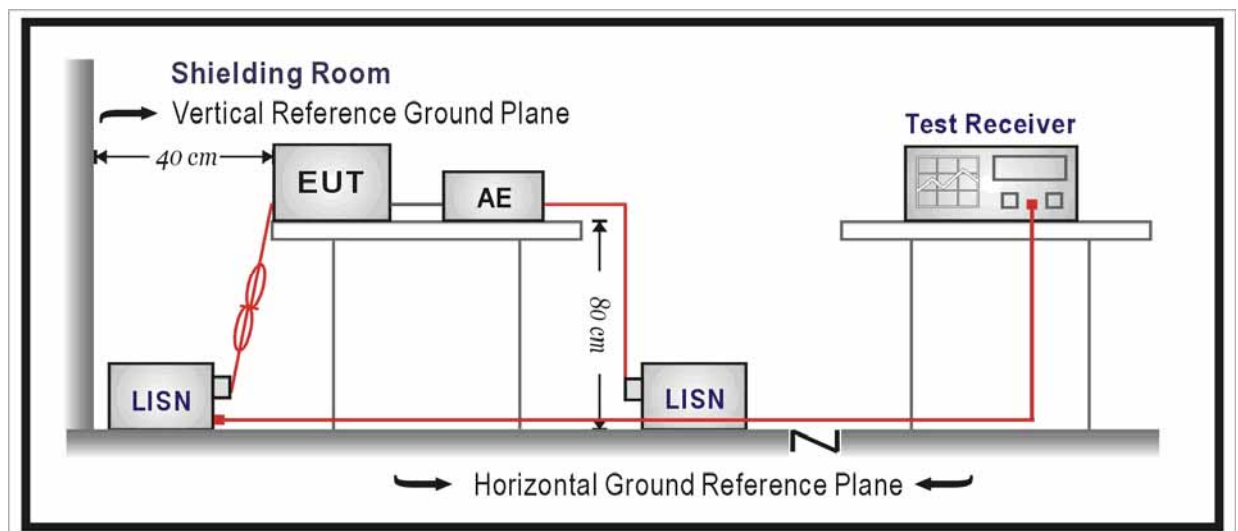

3.3. Limit

FCC Part 15 Subpart C Paragraph 15.207 Limits		
Frequency (MHz)	QP (dBuV)	AV (dBuV)
0.15 - 0.50	66 - 56	56 - 46
0.50 - 5.0	56	46
5.0 - 30	60	50

Note 1: The lower limit shall apply at the transition frequencies.

Note 2: The limit decreases linearly with the logarithm of the frequency in the range 0.15 MHz to 0.5 MHz.

3.4. Test Procedure

According to FCC ANSI C63.4: 2014 & ANSI C63.10: 2013.

The EUT was placed on a platform of nominal size, 1 m by 1.5 m, raised 80 cm above the conducting ground plane. The vertical conducting plane was located 40 cm to the rear of the EUT. All other surfaces of EUT were at least 80 cm from any other grounded conducting surface. The EUT and simulators are connected to the main power through a line impedance stabilization network (LISN). The LISN provides a 50 ohm /50uH coupling impedance for the measuring equipment. The peripheral devices are also connected to the main power through a LISN. (Please refer to the block diagram of the test setup and photographs)

Each current-carrying conductor of the EUT power cord, except the ground (safety) conductor, was individually connected through a LISN to the input power source.

The excess length of the power cord between the EUT and the LISN receptacle were folded back and forth at the center of the lead to form a bundle not exceeding 40 cm in length.

Conducted emissions were investigated over the frequency range from 0.15MHz to 30MHz using a receiver bandwidth of 9kHz.

3.5. Uncertainty

The measurement uncertainty is defined as ± 2.02 dB

3.6. Test Result

Engineer: Jack	
Site: TR1	Time: 2015/12/31
Limit: FCC_Part15.207_CE_AC Power_ClassB	Margin: 0
Probe: ENV216_101044(0.009-30MHz)	Polarity: Line
EUT: Verve Ones/Verve Ones+	Power: AC 120V/60Hz
Note: Mode 1	

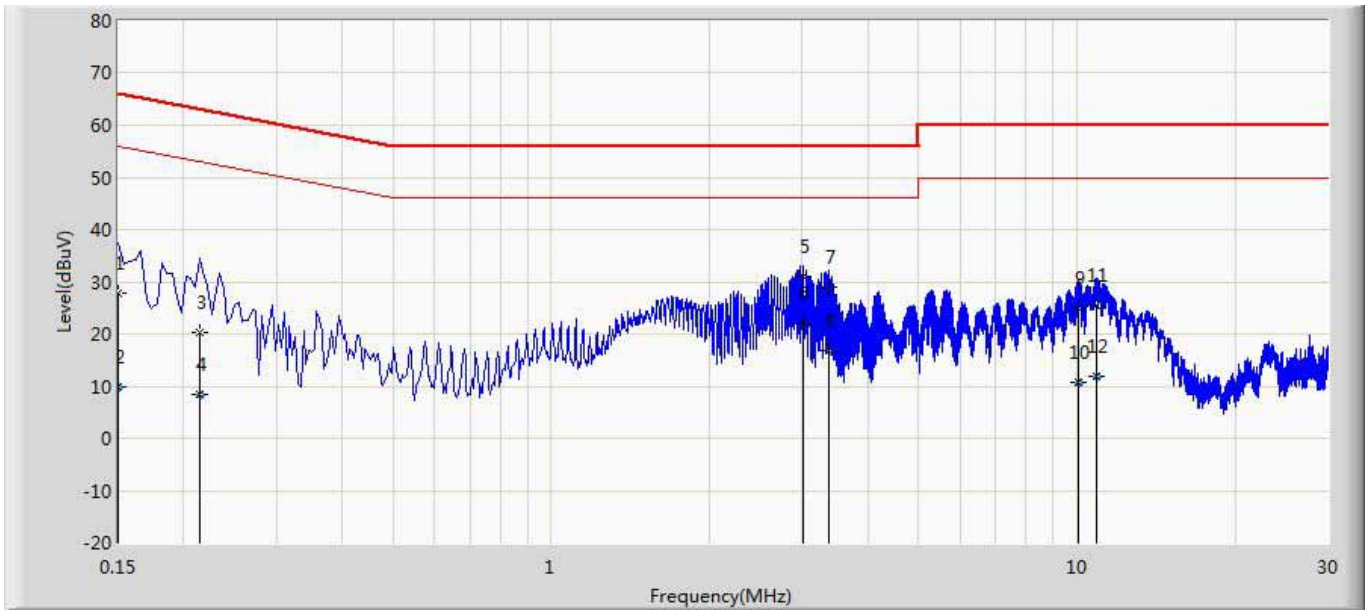

No	Mark	Frequency (MHz)	Measure Level (dBuV)	Reading Level (dBuV)	Over Limit (dB)	Limit (dBuV)	Probe (dB)	Cable (dB)	Amp (dB)	Type
1		0.150	27.876	18.057	-38.124	66.000	9.798	0.021	0.000	QP
2		0.150	9.854	0.035	-46.146	56.000	9.798	0.021	0.000	AV
3		0.214	20.248	10.413	-42.801	63.049	9.802	0.032	0.000	QP
4		0.214	8.455	-1.379	-44.593	53.049	9.802	0.032	0.000	AV
5		3.014	30.968	21.165	-25.032	56.000	9.693	0.111	0.000	QP
6	*	3.014	22.171	12.368	-23.829	46.000	9.693	0.111	0.000	AV
7		3.378	29.082	19.267	-26.918	56.000	9.695	0.120	0.000	QP
8		3.378	16.928	7.113	-29.072	46.000	9.695	0.120	0.000	AV
9		10.090	24.960	15.022	-35.040	60.000	9.731	0.207	0.000	QP
10		10.090	10.675	0.737	-39.325	50.000	9.731	0.207	0.000	AV
11		10.906	25.575	15.621	-34.425	60.000	9.739	0.215	0.000	QP
12		10.906	11.941	1.987	-38.059	50.000	9.739	0.215	0.000	AV

Engineer: Jack	
Site: TR1	Time: 2015/12/31
Limit: FCC_Part15.207_CE_AC Power_ClassB	Margin: 0
Probe: ENV216_101044(0.009-30MHz)	Polarity: Neutral
EUT: Verve Ones/Verve Ones+	Power: AC 120V/60Hz
Note: Mode 1	

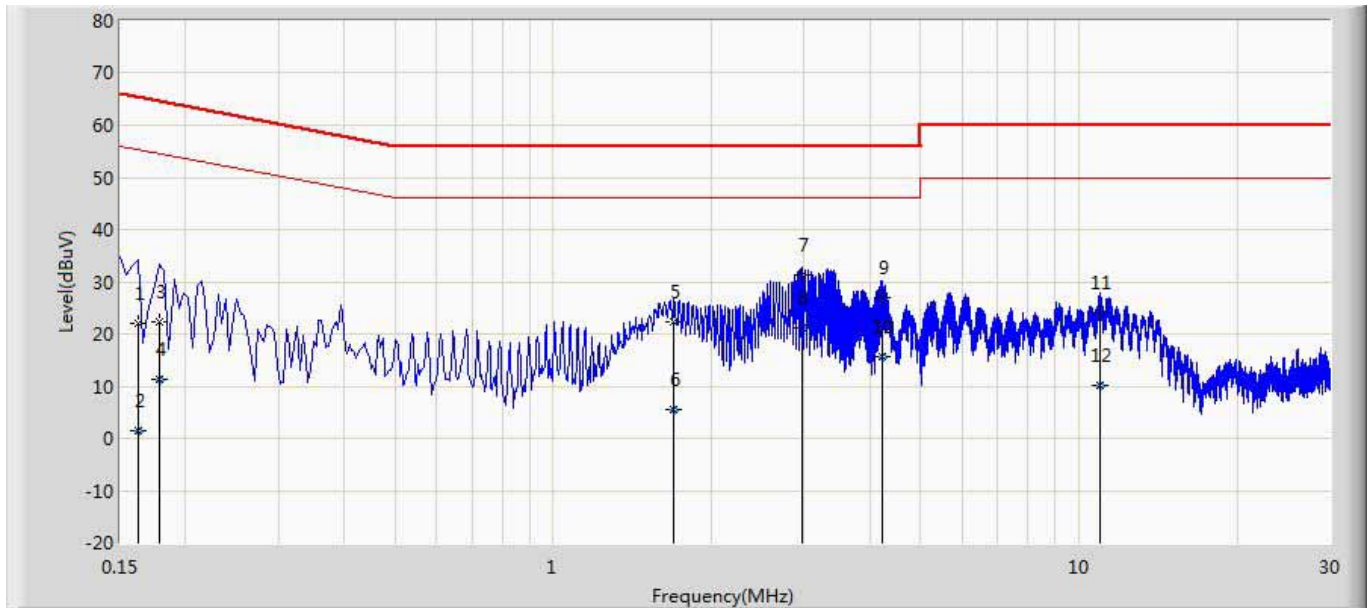

No	Mark	Frequency (MHz)	Measure Level (dBuV)	Reading Level (dBuV)	Over Limit (dB)	Limit (dBuV)	Probe (dB)	Cable (dB)	Amp (dB)	Type
1		0.162	22.049	12.095	-43.312	65.361	9.932	0.023	0.000	QP
2		0.162	1.430	-8.524	-53.931	55.361	9.932	0.023	0.000	AV
3		0.178	22.303	12.385	-42.275	64.578	9.893	0.025	0.000	QP
4		0.178	11.329	1.411	-43.249	54.578	9.893	0.025	0.000	AV
5		1.698	22.378	12.413	-33.622	56.000	9.883	0.081	0.000	QP
6		1.698	5.369	-4.595	-40.631	46.000	9.883	0.081	0.000	AV
7	*	2.982	31.392	21.408	-24.608	56.000	9.879	0.105	0.000	QP
8		2.982	21.245	11.260	-24.755	46.000	9.879	0.105	0.000	AV
9		4.234	26.992	16.944	-29.008	56.000	9.917	0.131	0.000	QP
10		4.234	15.538	5.489	-30.462	46.000	9.917	0.131	0.000	AV
11		10.958	23.930	13.653	-36.070	60.000	10.061	0.216	0.000	QP
12		10.958	10.110	-0.166	-39.890	50.000	10.061	0.216	0.000	AV

Note: All the low ,middle and high channels of all different modes are investigated, and only report the worst case.

4. Radiated Emission

4.1. Test Equipment

Radiated Emission / AC-2

Instrument	Manufacturer	Type No.	Serial No.	Cal. Due Date
EMI Test Receiver	R&S	ESCI	100573	2016.03.10
Loop Antenna	R&S	HFH2-Z2	833799/003	2016.11.25
Bilog Antenna	Teseq GmbH	CBL6112D	27611	2016.10.10
Coaxial Cable	Huber+Suhner	SUCOFLEX 106	AC2-C	2016.03.01
Temperature/Humidity Meter	Zhicheng	ZC1-2	AC2-TH	2017.01.07

Radiated Emission / AC-5

Instrument	Manufacturer	Type No.	Serial No.	Cal. Due Date
Spectrum Analyzer	Agilent	N9010A	MY48030494	2016.03.10
Preamplifier	Miteq	NSP1800-25	1364185	2016.05.03
Preamplifier	Quietek	AP-040G	CHM-0906001	2016.05.03
Bilog Antenna	Teseq GmbH	CBL6112D	27612	2016.10.15
Broad-Band Horn Antenna	Schwarzbeck	BBHA9120D	499	2016.06.08
Broad-Band Horn Antenna	Schwarzbeck	BBHA9170	294	2016.04.10
Coaxial Cable	Huber+Suhner	SUCOFLEX 106	AC5-C1	2016.03.01
Coaxial Cable	Huber+Suhner	SUCOFLEX 106	AC5-C2	2016.03.01
Coaxial Cable	Huber+Suhner	SUCOFLEX 102	AC5-C3	2016.03.01
Temperature/Humidity Meter	Zhicheng	ZC1-2	AC5-TH	2017.01.07

4.2. Test Setup

Below 30MHz Test Setup:

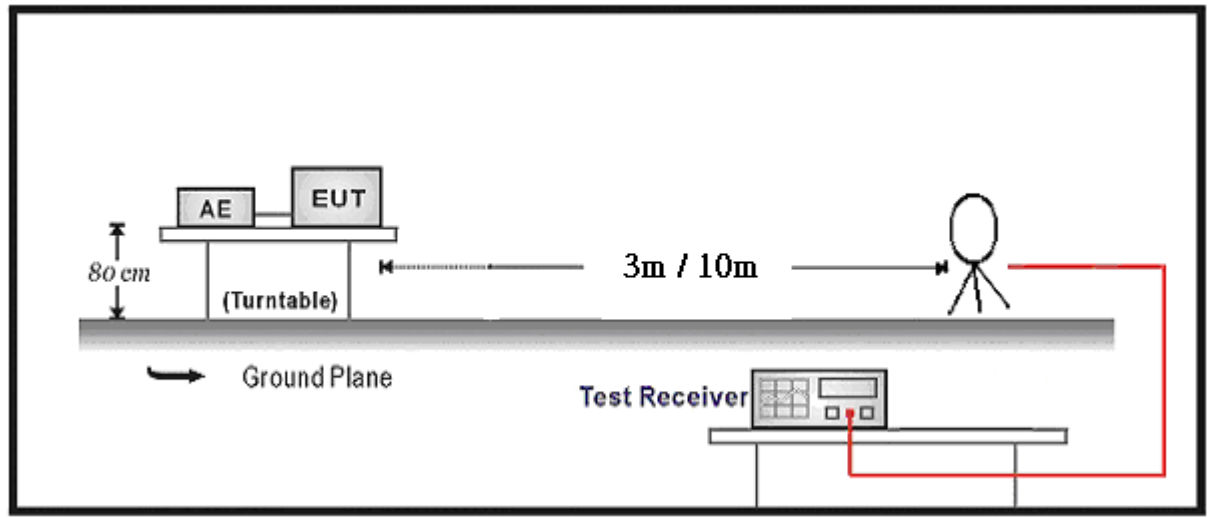

Below 1GHz Test Setup:

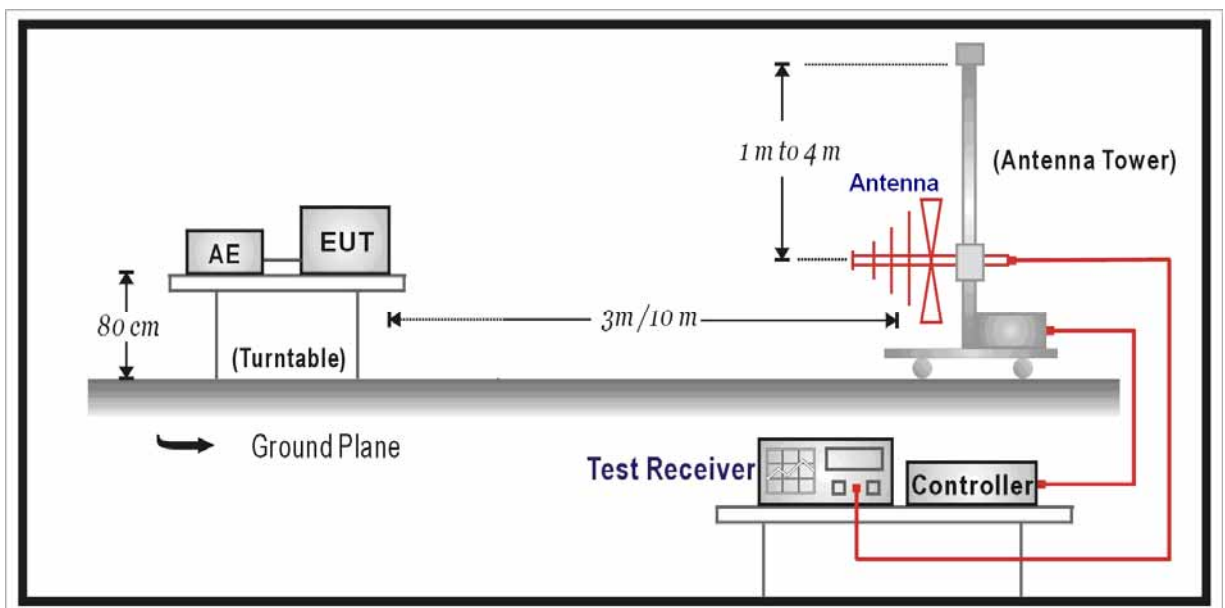

Above 1GHz Test Setup:

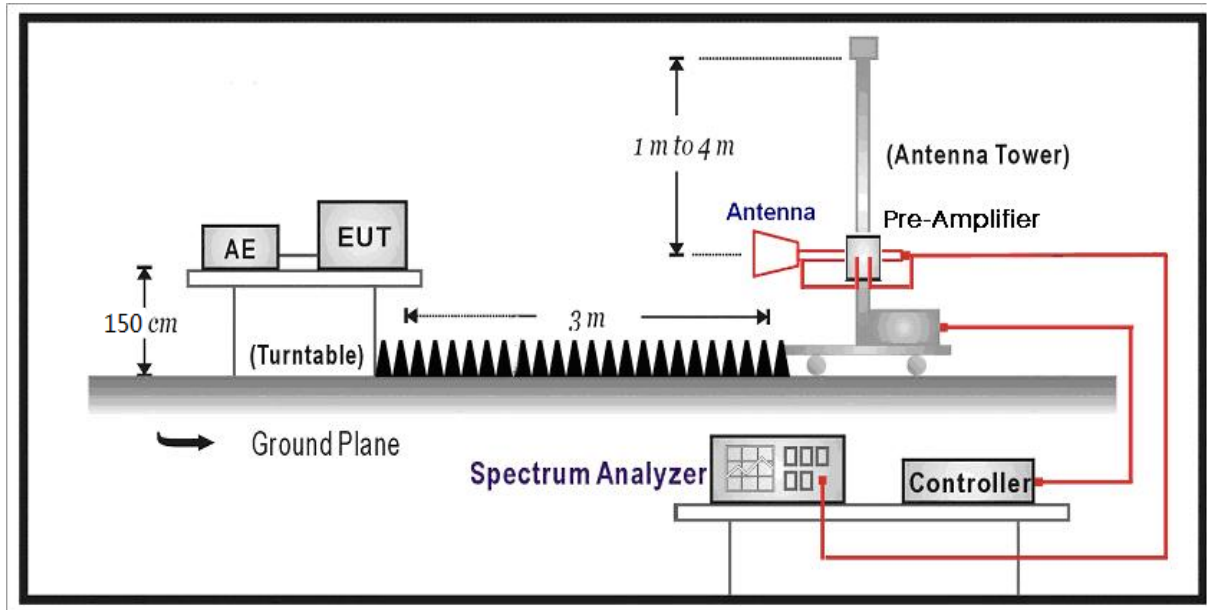

4.3. Limit

FCC Part 15 Subpart C Paragraph 15.209		
Frequency (MHz)	Distance (m)	Level (dBuV/m)
30 - 88	3	40
88 - 216	3	43.5
216 - 960	3	46
Above 960	3	54

Note 1: The lower limit shall apply at the transition frequency.

Note 2: Distance refers to the distance in meters between the measuring instrument antenna and the closed point of any part of the device or system.

Note 3: E field strength (dBuV/m) = $20 \log E$ field strength (μ V/m)

4.4. Test Procedure

According to ANSI C63.4: 2014; ANSI C63.10: 2013.

The EUT is placed on a turn table which is 1.5 meter for above 1G and 0.8 meter for below 1G above ground. The turn table is rotated 360 degrees to determine the position of the maximum emission level. The EUT was positioned such that the distance from antenna to the EUT was 3 meters.

The antenna is scanned from 1 meter to 4 meters to find out the maximum emission level. This is repeated for both horizontal and vertical polarization of the antenna. In order to find the maximum emission, all of the interface cables were manipulated according to ANSI C63.4: 2014 on radiated measurement.

The resolution bandwidth below 1GHz setting on the field strength meter is 120 kHz and above 1GHz is 1MHz.

The frequency range from 30MHz to 10th harmonic is checked.

Note: When doing emission measurement above 1GHz, the horn antenna will be bended down a little (as horn antenna has the narrow beamwidth) in order to keeping the antenna in the “cone of radiation” of EUT. The 3dB beamwidth is 60~10 degrees for H-plane and 90~10 degrees for E-plane.

According to ANSI C63.10: 2013& ANSI C63.4: 2014

This test is required for any spurious emission or modulation product that falls in a Restricted Band, as defined in Section 15.205 of FCC part 15. It must be performed with the highest gain of each type of antenna proposed for use with the EUT. Use the following spectrum analyzer settings:

Span = wide enough to fully capture the emission being measured

RBW = 1 MHz for $f \geq 1$ GHz, 100 kHz for $f < 1$ GHz

VBW \geq RBW

Sweep = auto

Detector function = peak

Trace = max hold

Follow the guidelines in ANSI C63.4 with respect to maximizing the emission by rotating the EUT, measuring the emission while the EUT is situated in three orthogonal planes (if appropriate), adjusting the measurement antenna height and polarization, etc. A pre-amp and a high pass filter are required for this test, in order to provide the measuring system with sufficient sensitivity. Allow the trace to stabilize. The peak reading of the emission, after being corrected by the antenna factor, cable loss, pre-amp gain, etc., is the peak field strength, which must comply with the limit specified in Section 15.35(b) of FCC part 15.

Now set the VBW to 10 Hz, while maintaining all of the other instrument settings. This peak level, once corrected, must comply with the limit specified in Section 15.209 of FCC Part 15. If the dwell time per channel of the hopping signal is less than 100 ms, then the reading obtained with the 10 Hz VBW may be further adjusted by a “duty cycle correction factor”, derived from $20\log(\text{dwell time}/100 \text{ ms})$, in an effort to demonstrate compliance with the 15.209 limit of FCC part 15.

If the emission on which a radiated measurement must be made is located at the edge of the authorized band of operation, then the alternative “marker-delta” method may be employed.

4.5. Uncertainty

The measurement uncertainty above 1G is defined as ± 3.9 dB
below 1G is defined as ± 3.8 dB

4.6. Test Result

Mode 1: Transmitter-1Mbps(GFSK_DH5)

CH	Antenna	Frequency (MHz)	Reading Level (dBuV/m)	Factor (dB)	Measure Level (dBuV/m)	Limit (dBuV/m)	Margin (dB)	Detector
0	H	4804.0	31.4	8.0	39.4	54(Note3)	-14.6	PK
	V	4804.0	31.9	8.0	39.9	54(Note3)	-14.1	PK
	H	7206.0	29.7	12.8	42.5	54(Note3)	-11.5	PK
	V	7206.0	29.6	12.8	42.4	54(Note3)	-11.6	PK
	H	9608.0	28.5	16.1	44.6	54(Note3)	-9.4	PK
	V	9608.0	28.4	16.0	44.4	54(Note3)	-9.6	PK
39	H	4882.0	30.8	8.2	39.0	54(Note3)	-15.0	PK
	V	4882.0	31.2	8.2	39.4	54(Note3)	-14.6	PK
	H	7324.0	29.9	13.0	42.9	54(Note3)	-11.1	PK
	V	7323.1	29.2	13.0	42.2	54(Note3)	-11.8	PK
	H	9764.0	26.5	16.2	42.7	54(Note3)	-11.3	PK
	V	9764.0	27.2	16.3	43.5	54(Note3)	-10.5	PK
78	H	4960.0	30.1	8.5	38.6	54(Note3)	-15.4	PK
	V	4960.0	30.2	8.5	38.7	54(Note3)	-15.3	PK
	H	7443.0	28.2	13.2	41.4	54(Note3)	-12.6	PK
	V	7440.0	29.8	13.2	43.0	54(Note3)	-11.0	PK
	H	9920.0	27.0	16.1	43.1	54(Note3)	-10.9	PK
	V	9920.0	27.1	16.1	43.2	54(Note3)	-10.8	PK

Note 1: The test frequency range, 9kHz~30MHz, 18GHz~25GHz, both of the worst case are at least 6dB below the limits, therefore no data appear in the report.

2: This limit applies for using average detector, if the test result on peak is lower than average limit, then average measurement needn't be performed.

3: Measure Level = Reading Level + Factor.

Mode 2: Transmitter-2Mbps(Pi/4 DQPSK _DH5)

CH	Antenna	Frequency (MHz)	Reading Level (dBuV/m)	Factor (dB)	Measure Level (dBuV/m)	Limit (dBuV/m)	Margin (dB)	Detector
0	H	4804.0	31.3	7.9	39.2	54(Note3)	-14.8	PK
	V	4804.0	32.5	8.0	40.5	54(Note3)	-13.5	PK
	H	7206.0	29.0	12.8	41.8	54(Note3)	-12.2	PK
	V	7206.0	32.1	12.8	44.9	54(Note3)	-9.1	PK
	H	9608.0	26.9	16.1	43.0	54(Note3)	-11.0	PK
	V	9608.0	28.8	16.1	44.9	54(Note3)	-9.1	PK
39	H	4882.0	30.5	8.2	38.7	54(Note3)	-15.3	PK
	V	4882.0	30.4	8.2	38.6	54(Note3)	-15.4	PK
	H	7324.0	28.9	13.0	41.9	54(Note3)	-12.1	PK
	V	7323.0	28.0	13.0	41.0	54(Note3)	-13.0	PK
	H	9764.0	28.1	16.3	44.4	54(Note3)	-9.6	PK
	V	9764.0	27.0	16.3	43.3	54(Note3)	-10.7	PK
78	H	4960.0	30.6	8.5	39.1	54(Note3)	-14.9	PK
	V	4960.0	30.4	8.6	39.0	54(Note3)	-15.0	PK
	H	7443.0	29.1	13.2	42.3	54(Note3)	-11.7	PK
	V	7440.0	29.0	13.2	42.2	54(Note3)	-11.8	PK
	H	9920.0	27.3	16.1	43.4	54(Note3)	-10.6	PK
	V	9920.0	28.0	16.1	44.1	54(Note3)	-9.9	PK

Note 1: The test frequency range, 9kHz~30MHz, 18GHz~25GHz, both of the worst case are at least 6dB below the limits, therefore no data appear in the report.

2: This limit applies for using average detector, if the test result on peak is lower than average limit, then average measurement needn't be performed.

3: Measure Level = Reading Level + Factor.

Mode 3: Transmitter-3Mbps(8DPSK_DH5)

CH	Antenna	Frequency (MHz)	Reading Level (dBuV/m)	Factor (dB)	Measure Level (dBuV/m)	Limit (dBuV/m)	Margin (dB)	Detector
0	H	4808.0	31.5	8.0	39.5	54(Note3)	-14.5	PK
	V	4808.0	31.8	7.9	39.7	54(Note3)	-14.3	PK
	H	7206.0	29.3	12.8	42.1	54(Note3)	-11.9	PK
	V	7206.0	29.3	12.8	42.1	54(Note3)	-11.9	PK
	H	9608.0	28.4	16.1	44.5	54(Note3)	-9.5	PK
	V	9608.0	27.9	16.0	43.9	54(Note3)	-10.1	PK
39	H	4882.0	30.9	8.2	39.1	54(Note3)	-14.9	PK
	V	4882.0	30.9	8.2	39.1	54(Note3)	-14.9	PK
	H	7323.0	28.8	13.0	41.8	54(Note3)	-12.2	PK
	V	7323.0	29.5	12.9	42.4	54(Note3)	-11.6	PK
	H	9764.0	27.8	16.3	44.1	54(Note3)	-9.9	PK
	V	9764.0	28.2	15.9	44.1	54(Note3)	-9.9	PK
78	H	4960.0	29.6	8.5	38.1	54(Note3)	-15.9	PK
	V	4960.0	30.7	8.6	39.3	54(Note3)	-14.7	PK
	H	7440.0	29.0	13.2	42.2	54(Note3)	-11.8	PK
	V	7440.0	29.0	13.2	42.2	54(Note3)	-11.8	PK
	H	9920.0	26.9	16.0	42.9	54(Note3)	-11.1	PK
	V	9920.0	28.3	16.0	44.3	54(Note3)	-9.7	PK

Note 1: The test frequency range, 9kHz~30MHz, 18GHz~25GHz, both of the worst case are at least 6dB below the limits, therefore no data appear in the report.

2: This limit applies for using average detector, if the test result on peak is lower than average limit, then average measurement needn't be performed.

3: Measure Level = Reading Level + Factor.

The worst case of Radiated Emission below 1GHz:

Engineer: Jack	
Site: AC3	Time: 2015/12/31
Limit: FCC_Part15.109_RE(3m)_ClassB	Margin: 0
Probe: AC3_10m (30-1000MHz)	Polarity: Horizontal
EUT: Verve Ones/Verve Ones+	Power: AC 120V/60Hz
Note: Mode 1	

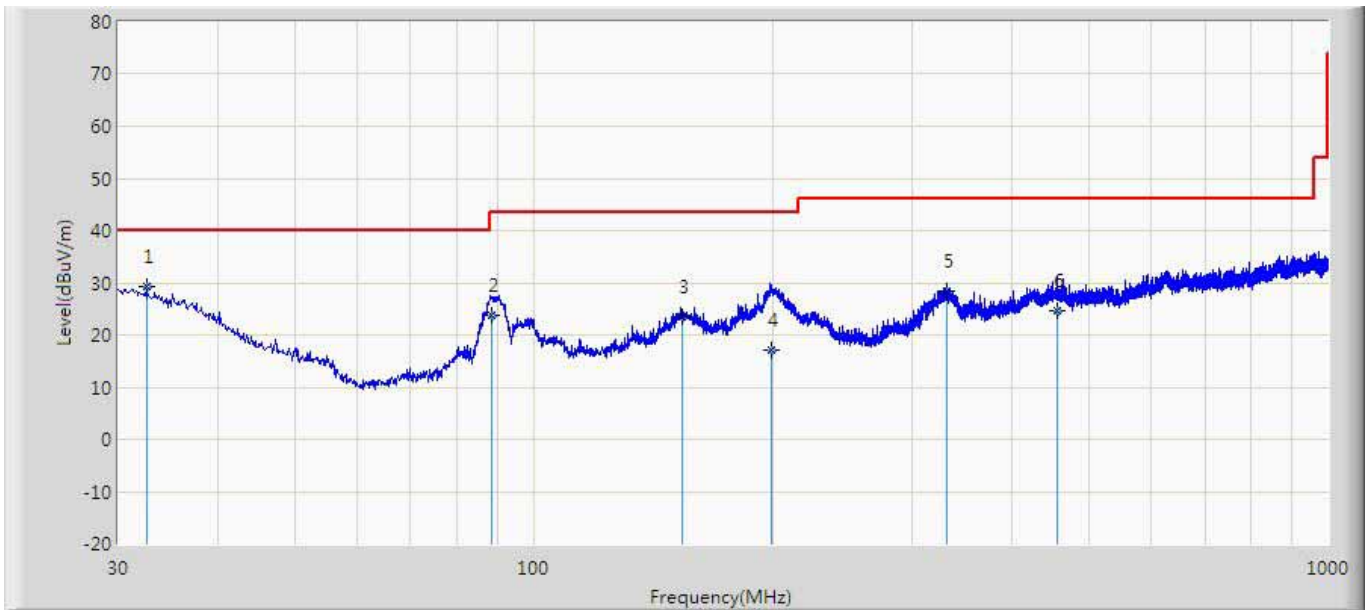

No	Mark	Frequency (MHz)	Measure Level (dBuV/m)	Reading Level (dBuV)	Over Limit (dB)	Limit (dBuV/m)	Probe (dB/m)	Cable (dB)	Amp (dB)	Ant Pos (cm)	Table Pos (deg)	Type
1	*	32.615	29.351	2.835	-10.649	40.000	20.048	6.469	0.000	175	360	QP
2		88.625	23.662	10.434	-19.838	43.500	6.432	6.796	0.000	200	36	QP
3		153.712	23.487	6.160	-20.013	43.500	10.235	7.092	0.000	200	63	QP
4		199.167	17.165	-0.578	-26.335	43.500	10.457	7.285	0.000	200	70	QP
5		331.700	28.482	5.703	-17.518	46.000	15.067	7.712	0.000	100	10	QP
6		455.518	24.648	-2.418	-21.352	46.000	19.015	8.051	0.000	100	136	QP

Note:

1. " * ", means this data is the worst emission level.
2. Measurement Level = Reading Level + Factor(Probe+Cable-Amp).

Engineer: Jack	
Site: AC3	Time: 2015/12/31
Limit: FCC_Part15.109_RE(3m)_ClassB	Margin: 0
Probe: AC3_10m (30-1000MHz)	Polarity: Vertical
EUT: Verve Ones/Verve Ones+	Power: AC 120V/60Hz
Note: Mode 1	

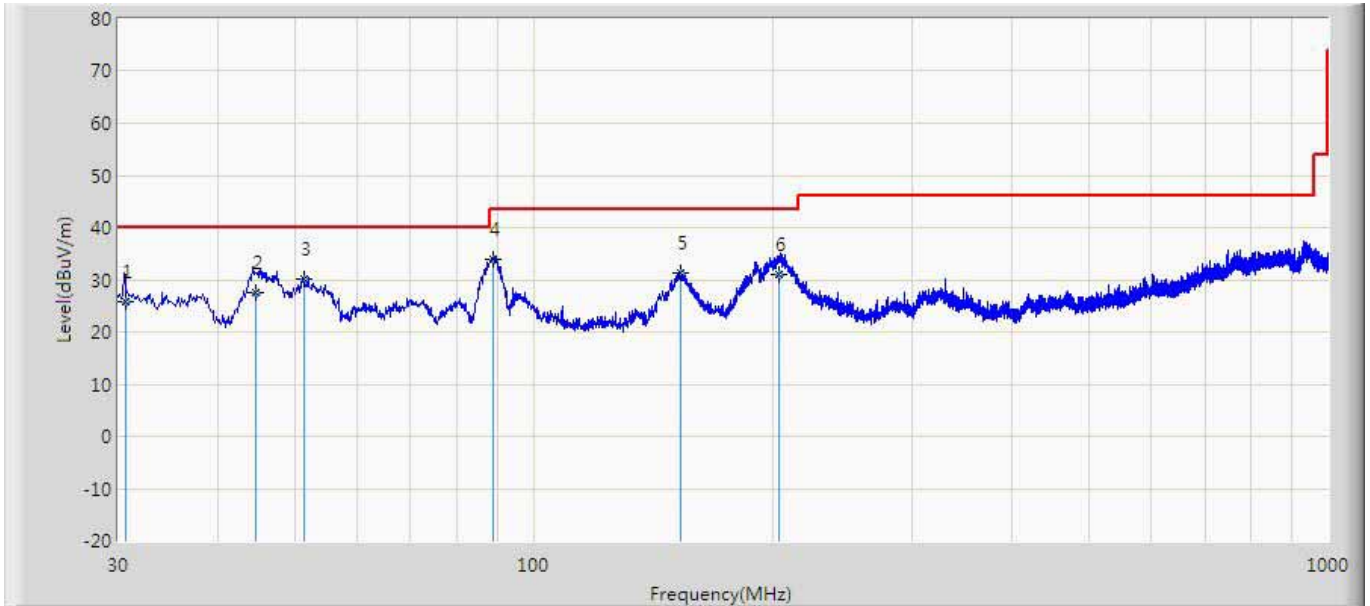

No	Mark	Frequency (MHz)	Measure Level (dBuV/m)	Reading Level (dBuV)	Over Limit (dB)	Limit (dBuV/m)	Probe (dB/m)	Cable (dB)	Amp (dB)	Ant Pos (cm)	Table Pos (deg)	Type
1		30.665	25.779	1.888	-14.221	40.000	17.433	6.458	0.000	100	193	QP
2		44.672	27.508	9.907	-12.492	40.000	11.044	6.557	0.000	100	158	QP
3		51.426	30.003	12.132	-9.997	40.000	11.276	6.595	0.000	100	198	QP
4	*	88.918	33.830	17.046	-9.670	43.500	9.985	6.799	0.000	100	240	QP
5		152.902	31.356	12.683	-12.144	43.500	11.586	7.087	0.000	100	329	QP
6		203.657	30.980	8.068	-12.520	43.500	15.617	7.296	0.000	100	2	QP

Note:

1. " * ", means this data is the worst emission level.
2. Measurement Level = Reading Level + Factor(Probe+Cable-Amp).

5. 20dB Bandwidth

5.1 Test Equipment

20dB Bandwidth / TR8

Instrument	Manufacturer	Type No.	Serial No.	Cal. Due Date
Spectrum Analyzer	Agilent	N9010A	MY48030494	2016.03.10
Temperature/Humidity Meter	Zhicheng	ZC1-2	TR8-TH	2016.04.09

Note: All equipments are calibrated with traceable calibrations. Each calibration is traceable to the national or international standards.

5.2 Test Setup

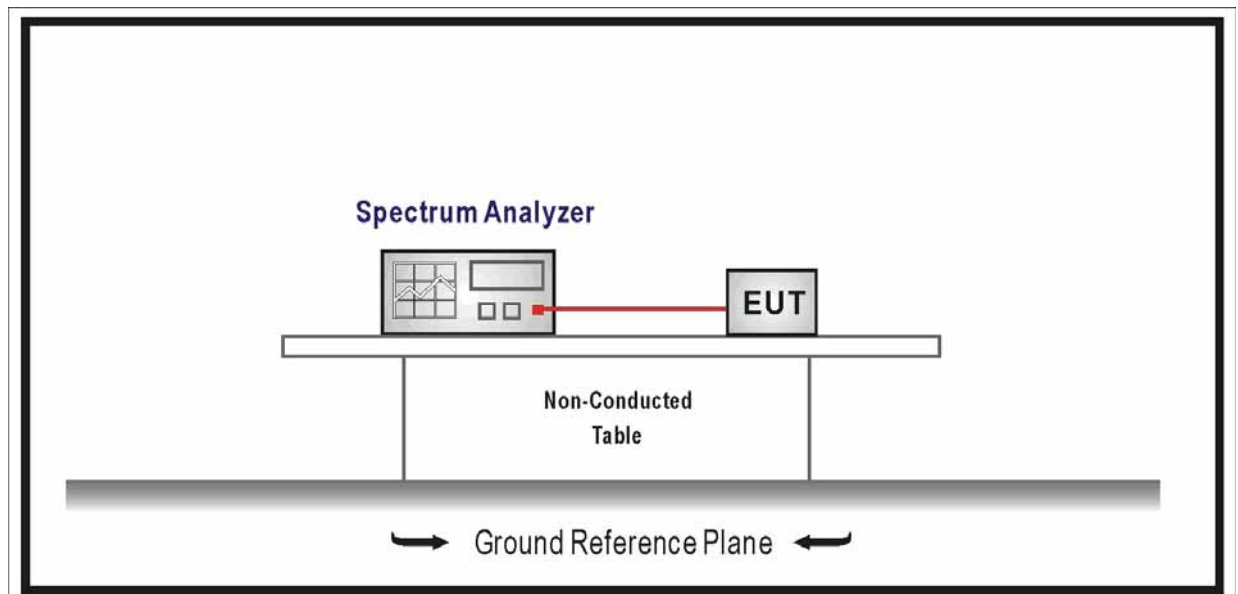

5.3 Limit

- For frequency hopping systems operating in 2400-2483.5 MHz band, no limitation.
- For frequency hopping systems operating in 902-928 MHz band, the maximum allowed 20 dB bandwidth of the hopping channel is 500 kHz.
- For frequency hopping systems operating in 5725-5850 MHz band, the maximum 20 dB bandwidth of the hopping channel is 1 MHz.

5.4 Test Procedure

According to ANSI C63.10: 2013& ANSI C63.4: 2014

Use the following spectrum analyzer settings:

Span = approximately 2 to 3 times the 20dB bandwidth, centered on a hopping channel

RBW \cong 1% of the 20dB bandwidth

VBW \cong RBW

Sweep = auto

Detector function = peak

Trace = max hold

The EUT should be transmitting at its maximum data rate. Allow the trace to stabilize.

Use the marker-to-peak function to set the marker to the peak of the emission. Use the marker-delta function to measure 20 dB down one side of the emission. Reset the marker-delta function, and move the marker to the other side of the emission, until it is (as close as possible to) even with the reference marker level. The marker-delta reading at this point is the 20 dB bandwidth of the emission. If this value varies with different modes of operation (e.g., data rate, modulation format, etc.), repeat this test for each variation.

5.5 Uncertainty

The measurement uncertainty is defined as ± 1 kHz

5.6 Test Result

Product	:	Verve Ones/Verve Ones+
Test Item	:	Occupied Bandwidth
Test Site	:	TR-8
Test Mode	:	Mode 1: Transmitter-1Mbps (GFSK_DH5)

Channel No.	Frequency (MHz)	20dB Bandwidth (kHz)	99% Bandwidth (kHz)
00	2402	927.30	882.93
39	2441	927.40	869.46
78	2480	926.10	866.17

Channel 00 (2402MHz)

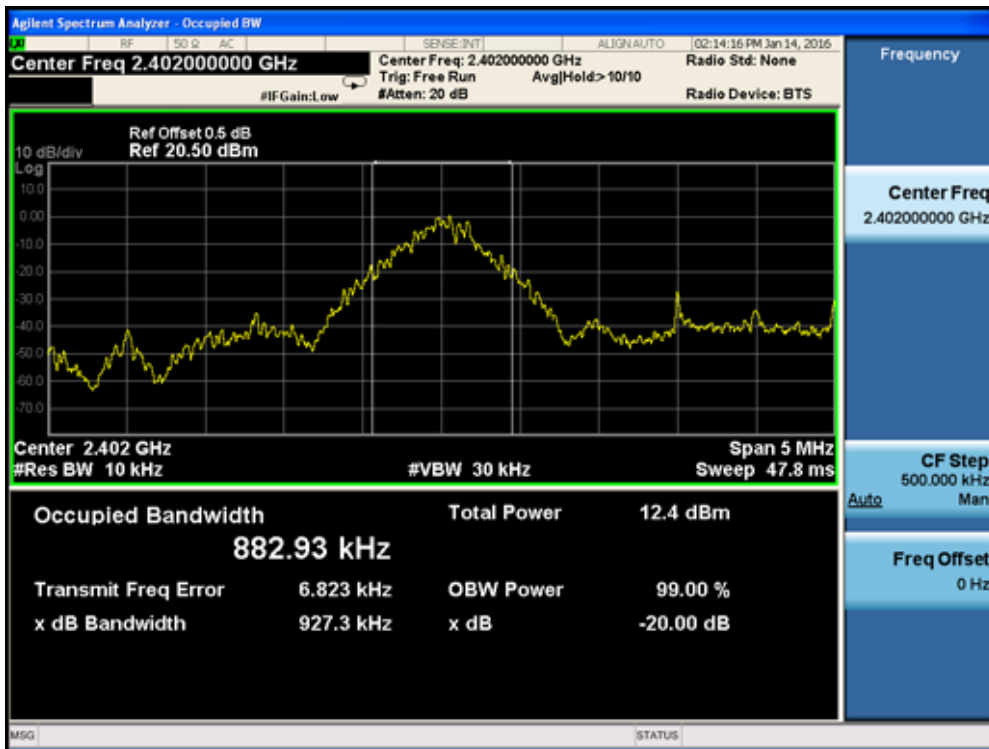

Channel 39 (2441MHz)

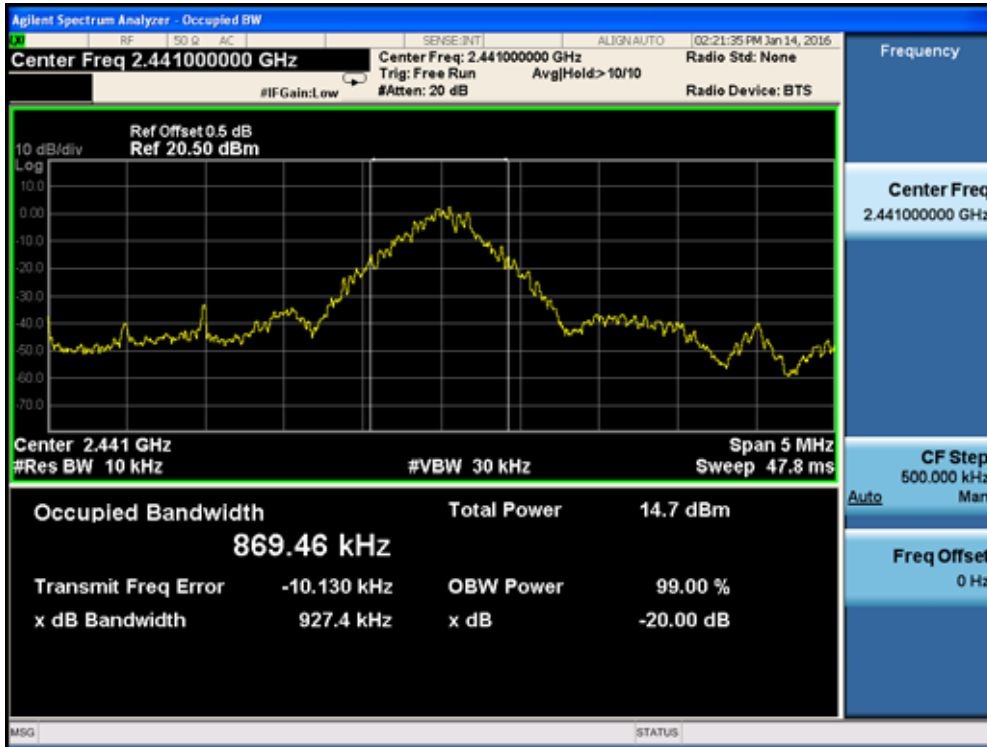

Channel 78 (2480MHz)

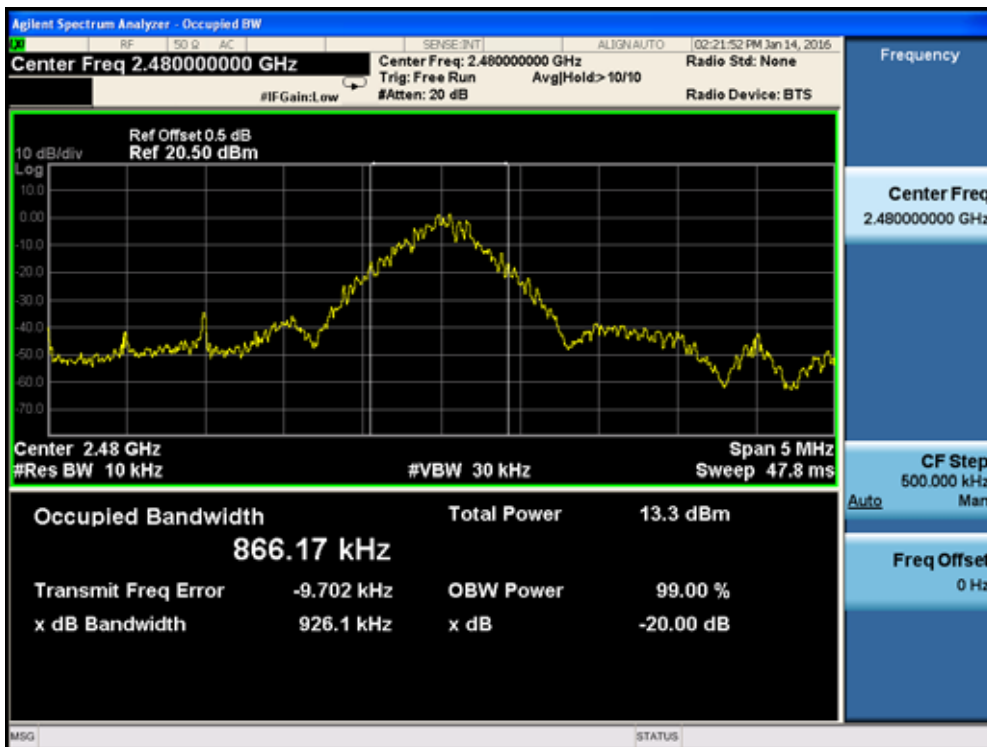

Product	: Verve Ones/Verve Ones+
Test Item	: Occupied Bandwidth
Test Site	: TR-8
Test Mode	: Mode 2: Transmitter-2Mbps (Pi/4 DQPSK_DH5)

Channel No.	Frequency (MHz)	20dB Bandwidth (kHz)	99% Bandwidth (kHz)
00	2402	1219.0	1166.7
39	2441	1219.0	1165.2
78	2480	1220.0	1166.5

Channel 00 (2402MHz)

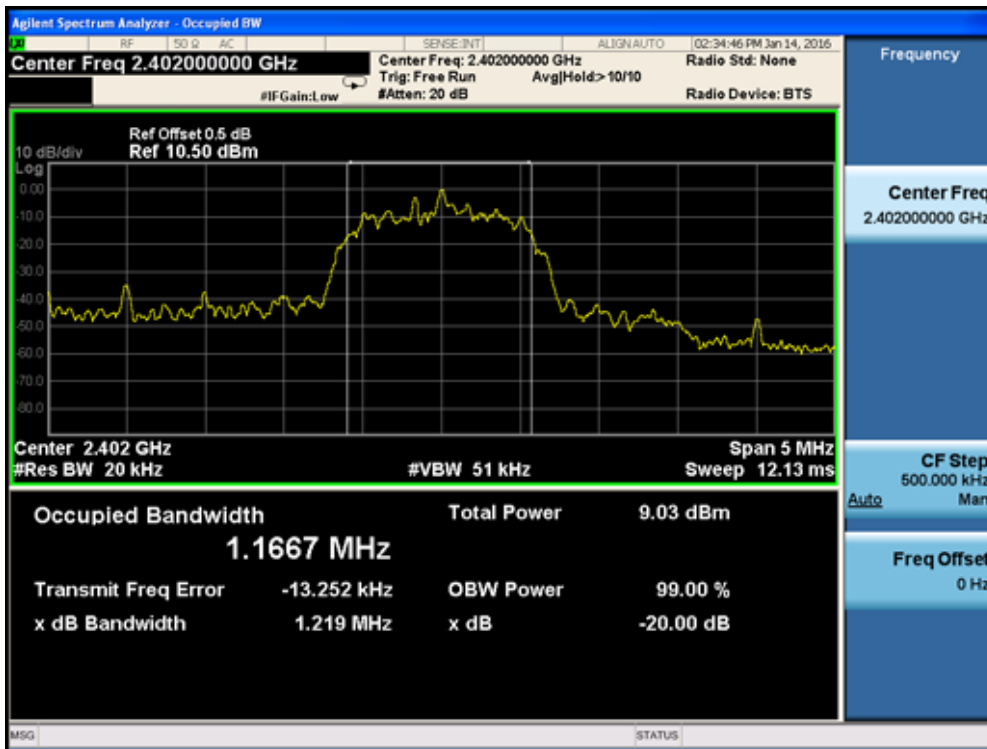

Channel 39 (2441MHz)

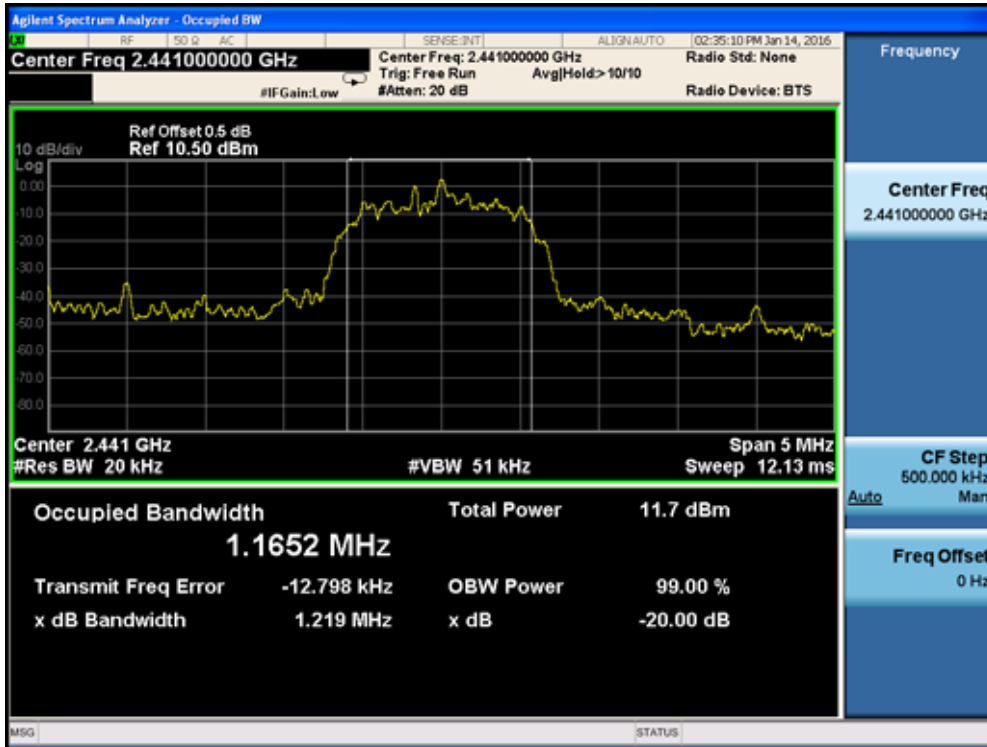

Channel 78 (2480MHz)



Product	: Verve Ones/Verve Ones+
Test Item	: Occupied Bandwidth
Test Site	: TR-8
Test Mode	: Mode 3: Transmitter-3Mbps (8DPSK_DH5)

Channel No.	Frequency (MHz)	20dB Bandwidth (kHz)	99% Bandwidth (kHz)
00	2402	1219.0	1166.4
39	2441	1223.0	1168.5
78	2480	1209.0	1163.4

Channel 00 (2402MHz)

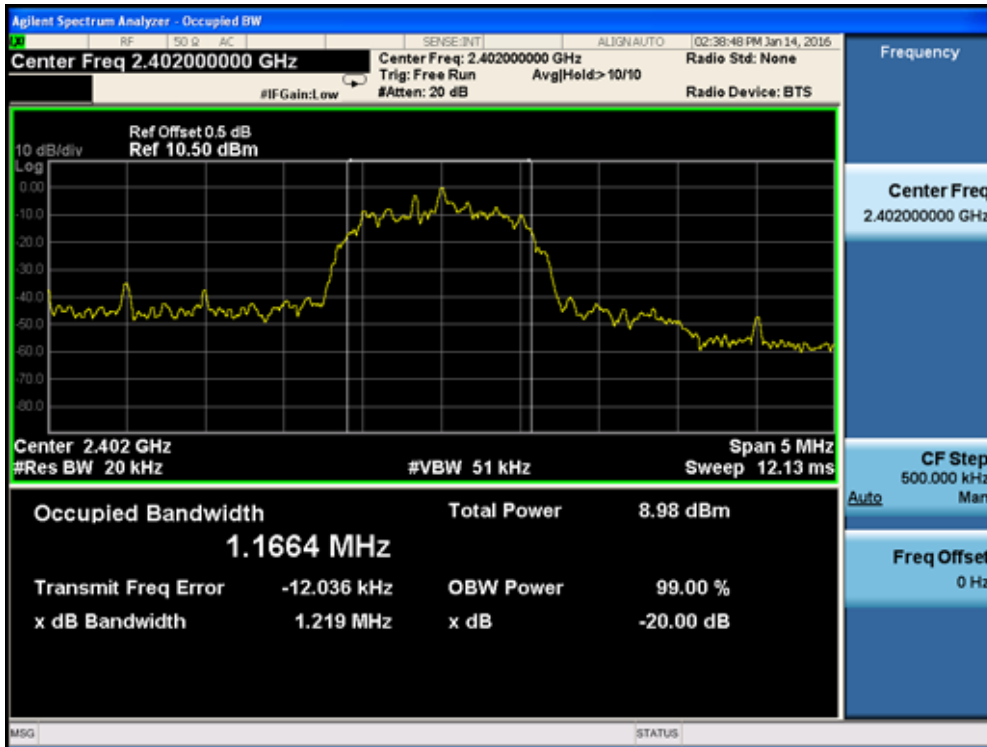

Channel 39 (2441MHz)

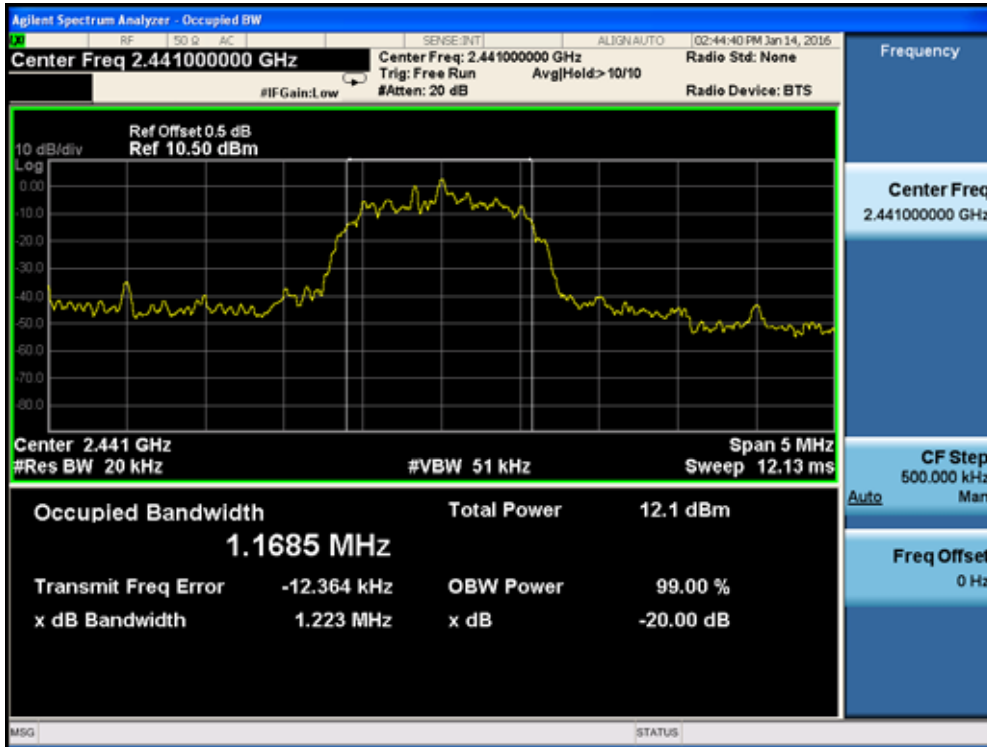

Channel 78 (2480MHz)



6. Carrier Frequency Separation

6.1. Test Equipment

Carrier Frequency Separation / TR-8

Instrument	Manufacturer	Type No.	Serial No.	Cal. Due Date
Spectrum Analyzer	Agilent	N9010A	MY48030494	2016.03.10
Temperature/Humidity Meter	Zhicheng	ZC1-2	TR8-TH	2016.04.09

Note: All equipments are calibrated with traceable calibrations. Each calibration is traceable to the national or international standards.

6.2. Test Setup

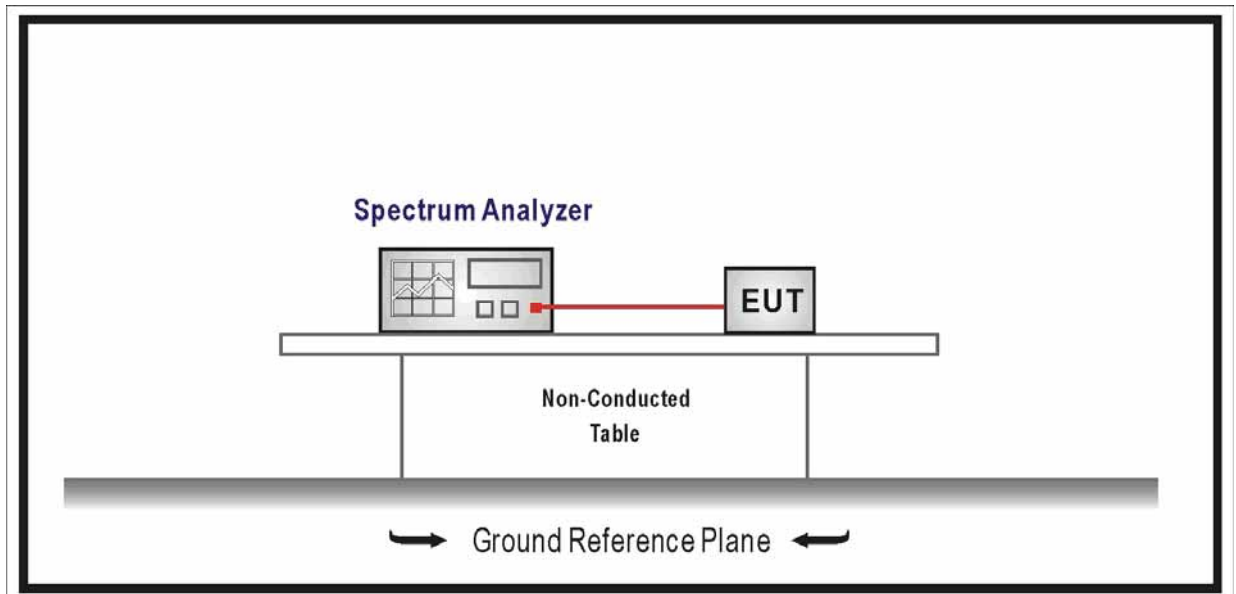

6.3. Limit

- Frequency hopping systems shall have hopping channel carrier frequencies separated by a minimum of 25 kHz or the 20 dB bandwidth of the hopping channel, whichever is greater. Alternatively, frequency hopping systems operating in the 2400-2483.5 MHz band may have hopping channel carrier frequencies that are separated by 25 kHz or two-thirds of the 20 dB bandwidth of the hopping channel, whichever is greater, provided the systems operate with an output power no greater than 125mW. The system shall hop to channel frequencies that are selected at the system hopping rate from a pseudorandomly ordered list of hopping frequencies. Each frequency must be used equally on the average by each transmitter. The system receivers shall have input bandwidths that match the hopping

channel bandwidths of their corresponding transmitters and shall shift frequencies in synchronization with the transmitted signals.

- For frequency hopping systems operating in the 902-928 MHz band: if the 20 dB bandwidth of the hopping channel is less than 250 kHz, the system shall use at least 50 hopping frequencies and the average time of occupancy on any frequency shall not be greater than 0.4 seconds within a 20 second period; If the 20 dB bandwidth of the hopping channel is 250 kHz or greater, the system shall use at least 25 hopping frequencies and the average time of occupancy on any frequency shall not be greater than 0.4 seconds within a 10 second period. The maximum allowed 20 dB bandwidth of the hopping channel is 500 kHz.
- Frequency hopping systems operating in the 5725-5850 MHz band shall use at least 75 hopping frequencies. The maximum 20 dB bandwidth of the hopping channel is 1 MHz. The average time of occupancy on any frequency shall not be greater than 0.4 seconds within a 30 second period.

6.4. Test Procedure

According to ANSI C63.10: 2013& ANSI C63.4: 2014

The EUT must have its hopping function enabled. Use the following spectrum analyzer settings:

Span = wide enough to capture the peaks of two adjacent channels

Resolution (or IF) Bandwidth (RBW) \geq 1% of the span

Video (or Average) Bandwidth VBW \geq RBW

Sweep = auto

Detector function = peak

Trace = max hold

Allow the trace to stabilize. Use the marker-delta function to determine the separation between the peaks of the adjacent channels.

6.5. Uncertainty

The measurement uncertainty is defined as ± 1 kHz

6.6. Test Result

Product	:	Verve Ones/Verve Ones+
Test Item	:	Carrier Frequency Separation
Test Site	:	TR-8
Test Mode	:	Mode 1: Transmitter-1Mbps (GFSK_DH5)

Channel No.	Frequency (MHz)	Carrier Frequency Separation (kHz)	Limit (kHz)	Result
00	2402	1000	>25 kHz or 2/3 of 20 dB BW	Pass
39	2441	1000	>25 kHz or 2/3 of 20 dB BW	Pass
78	2480	1000	>25 kHz or 2/3 of 20 dB BW	Pass

Channel 00 (2402MHz)

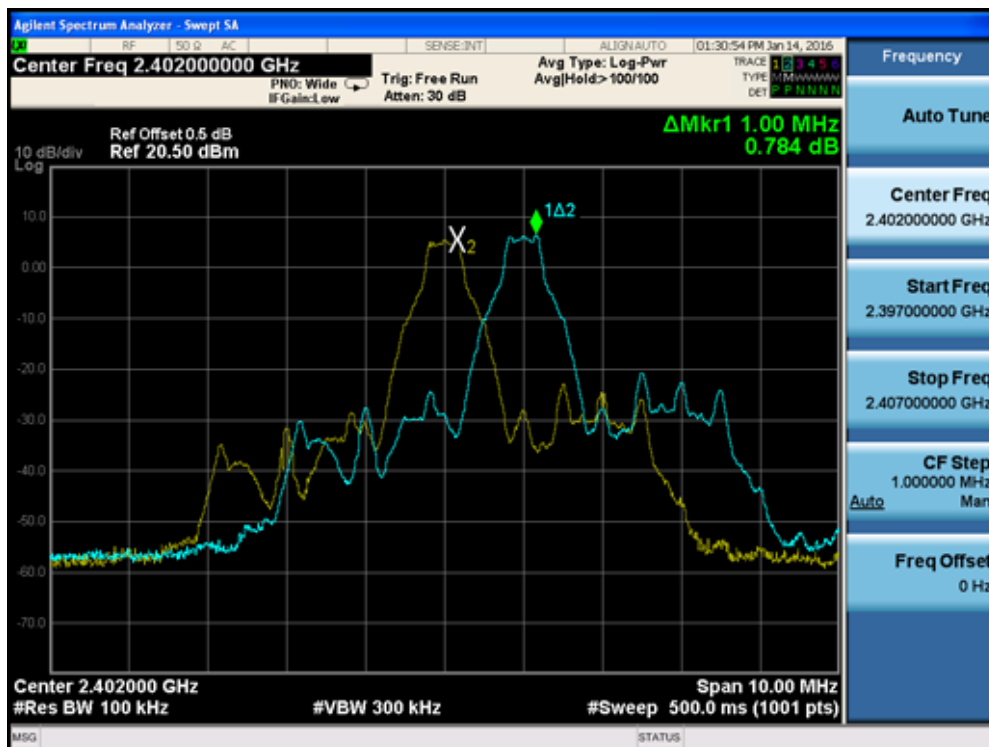

Channel 39 (2441MHz)

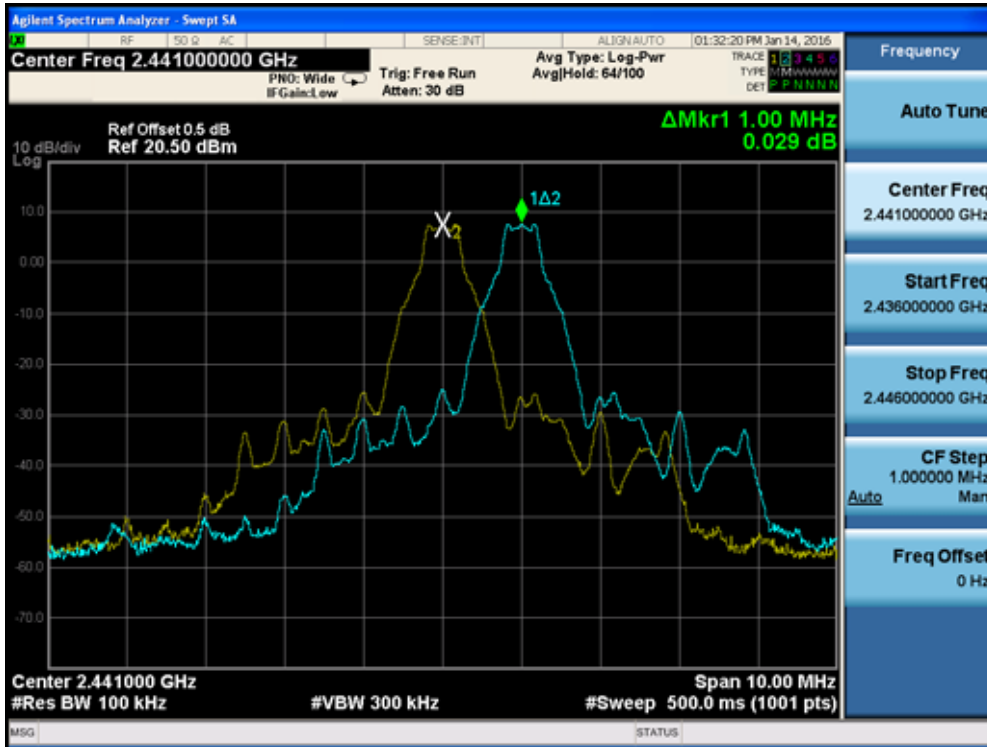

Channel 78 (2480MHz)

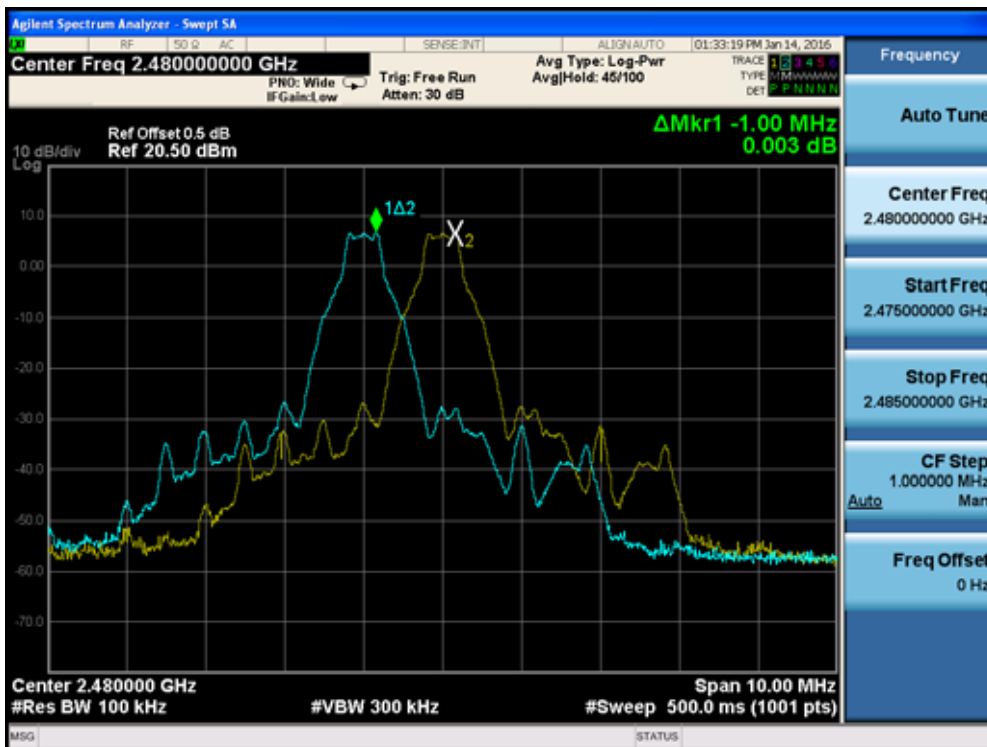

Product	:	Verve Ones/Verve Ones+
Test Item	:	Carrier Frequency Separation
Test Site	:	TR-8
Test Mode	:	Mode 2: Transmitter-2Mbps (Pi/4 DQPSK_DH5)

Channel No.	Frequency (MHz)	Carrier Frequency Separation (kHz)	Limit (kHz)	Result
00	2402	1000	>25 kHz or 2/3 of 20 dB BW	Pass
39	2441	1000	>25 kHz or 2/3 of 20 dB BW	Pass
78	2480	1000	>25 kHz or 2/3 of 20 dB BW	Pass

Channel 00 (2402MHz)

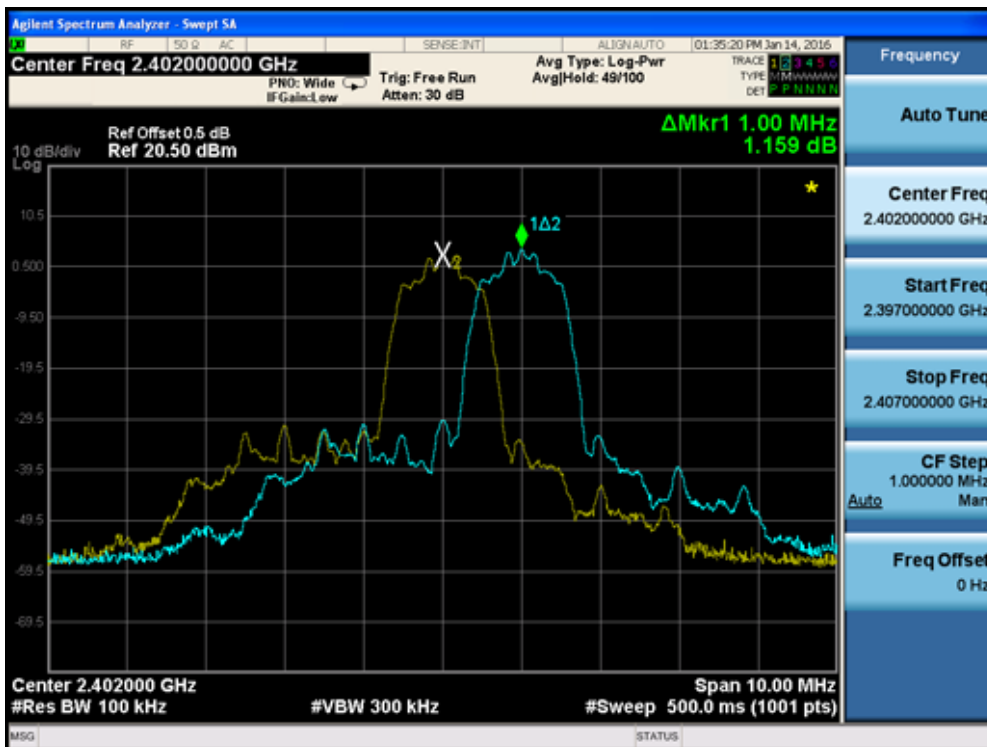

Channel 39 (2441MHz)

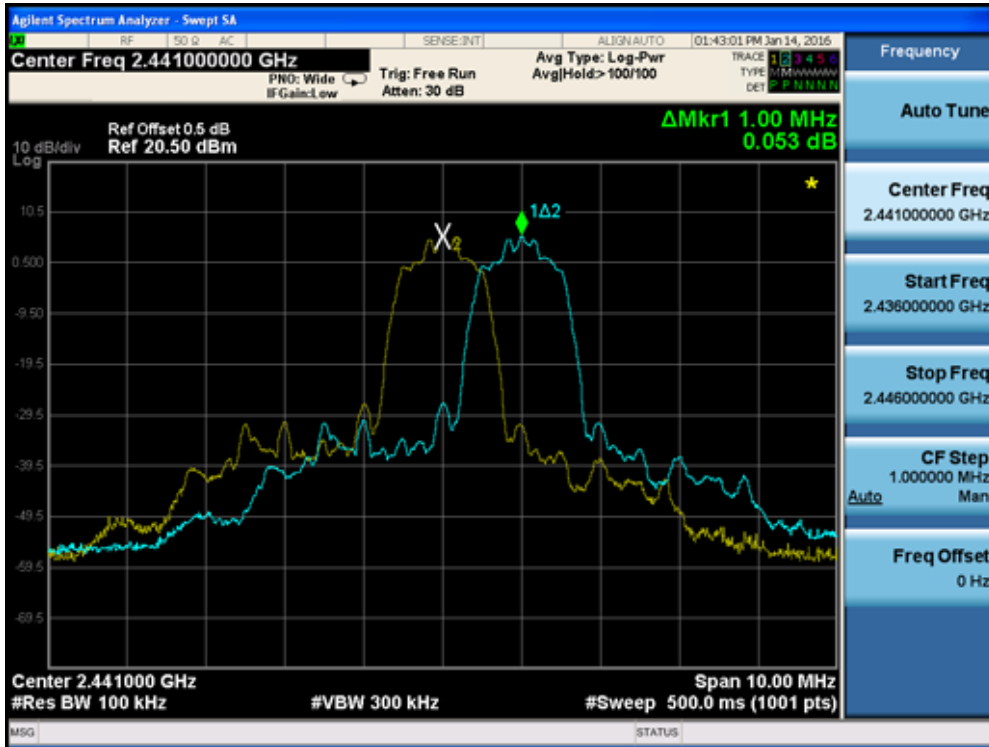

Channel 78 (2480MHz)

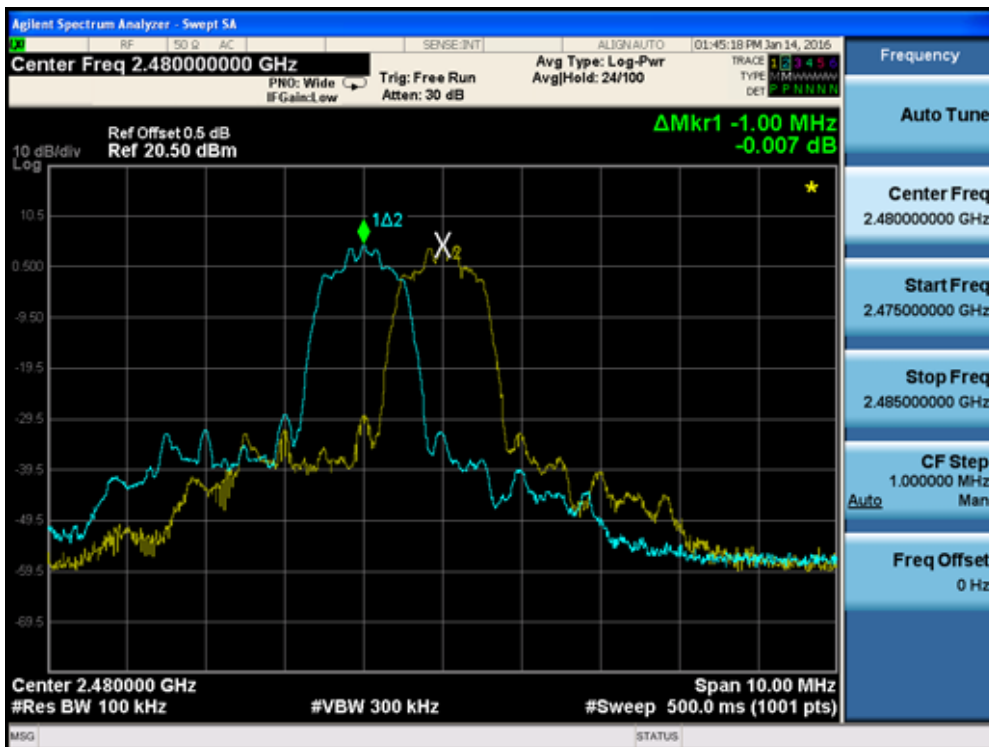

Product	:	Verve Ones/Verve Ones+
Test Item	:	Carrier Frequency Separation
Test Site	:	TR-8
Test Mode	:	Mode 3: Transmitter-3Mbps (8DPSK_DH5)

Channel No.	Frequency (MHz)	Carrier Frequency Separation (kHz)	Limit (kHz)	Result
00	2402	1000	>25 kHz or 2/3 of 20 dB BW	Pass
39	2441	1000	>25 kHz or 2/3 of 20 dB BW	Pass
78	2480	1000	>25 kHz or 2/3 of 20 dB BW	Pass

Channel 00 (2402MHz)

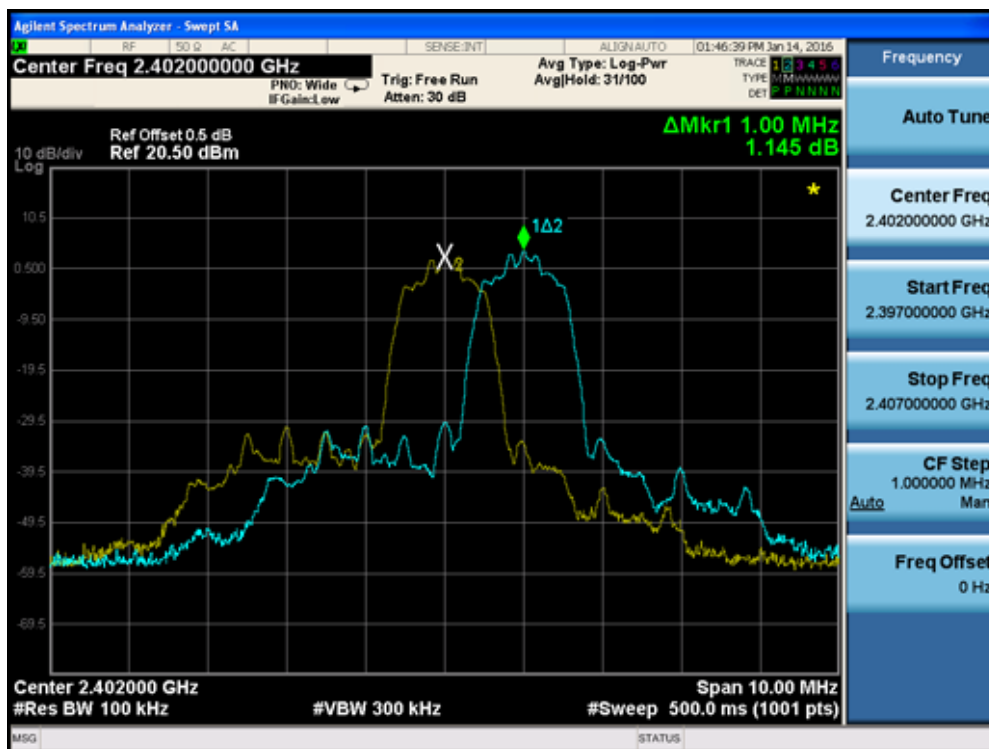

Channel 39 (2441MHz)

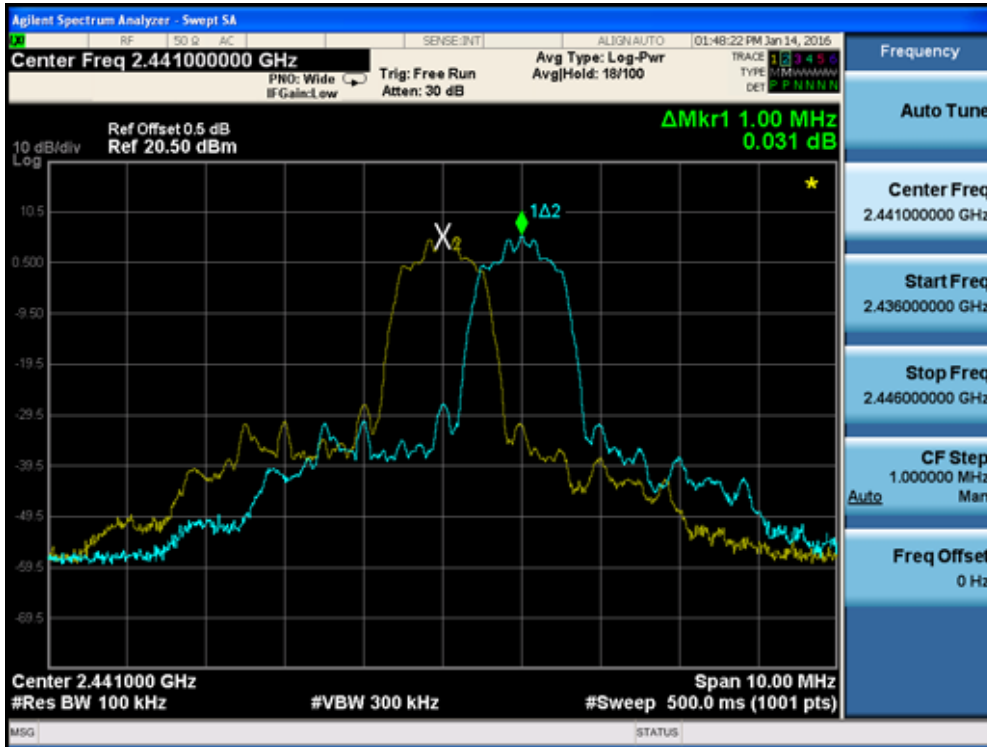

Channel 78 (2480MHz)

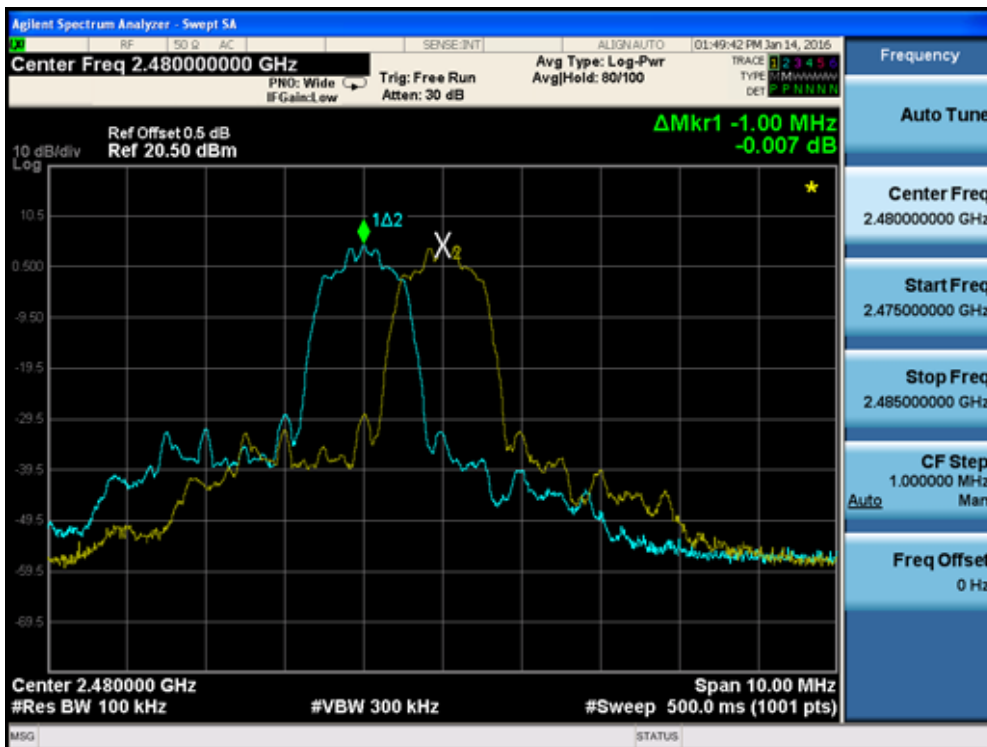

7. Number of Hopping Frequencies

7.1. Test Equipment

Number of Hopping Frequencies / TR-8

Instrument	Manufacturer	Type No.	Serial No.	Cal. Due Date
Spectrum Analyzer	Agilent	N9010A	MY48030494	2016.03.10
Temperature/Humidity Meter	Zhicheng	ZC1-2	TR8-TH	2016.04.09

Note: All equipments are calibrated with traceable calibrations. Each calibration is traceable to the national or international standards.

7.2. Test Setup

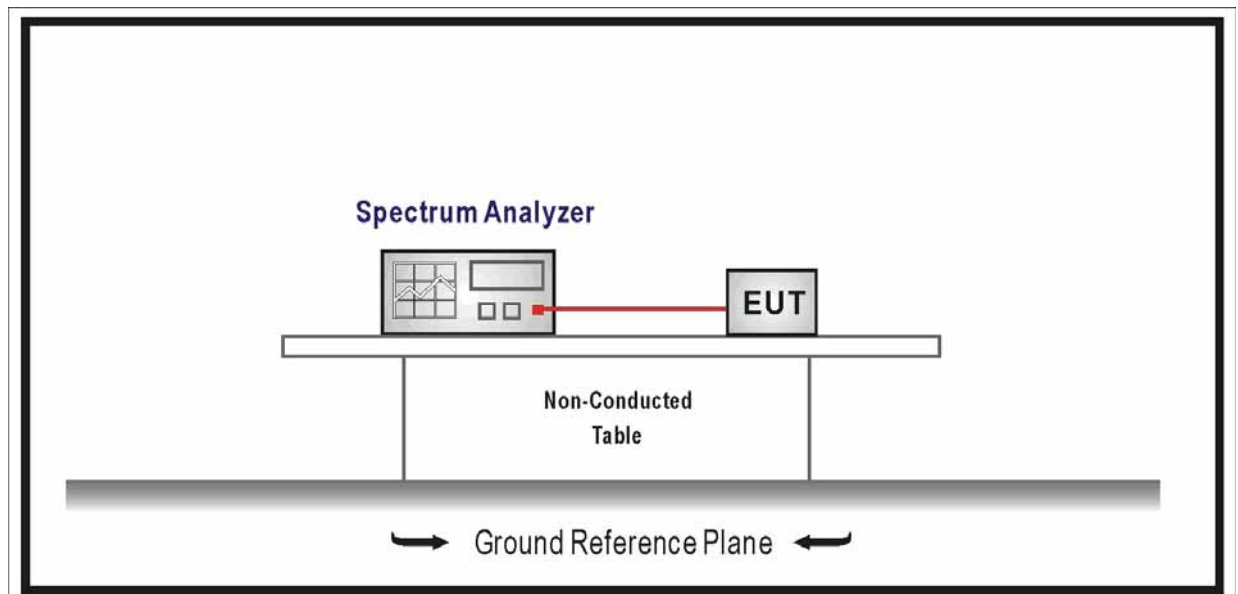

7.3. Limit

- For frequency hopping systems operating in the 2400-2483.5 MHz band shall use at least 15 hopping frequencies.
- For frequency hopping systems operating in 902-928 MHz band shall use at least 50 hopping frequencies.
- For frequency hopping systems operating in the 5725-5850 MHz band shall use at least 75 hopping frequencies.

7.4. Test Procedure

According to ANSI C63.10: 2013& ANSI C63.4: 2014

The EUT must have its hopping function enabled. Use the following spectrum analyzer settings:

Span = the frequency band of operation

RBW \cong 1% of the span

VBW \cong RBW

Sweep = auto

Detector function = peak

Trace = max hold

Allow the trace to stabilize. It may prove necessary to bread the span up to sections, in order to clearly show all of the hopping frequencies.

7.5. Uncertainty

The measurement uncertainty is defined as ± 1 kHz

7.6. Test Result

Product	:	Verve Ones/Verve Ones+
Test Item	:	Number of Hopping Frequencies
Test Site	:	TR-8
Test Mode	:	Mode 1: Transmitter-1Mbps (GFSK_DH5)

Frequency Band (MHz)	Number of Hopping Frequencies	Limit	Result
2400 - 2483.5	79	>15	Pass

2402 - 2441 MHz

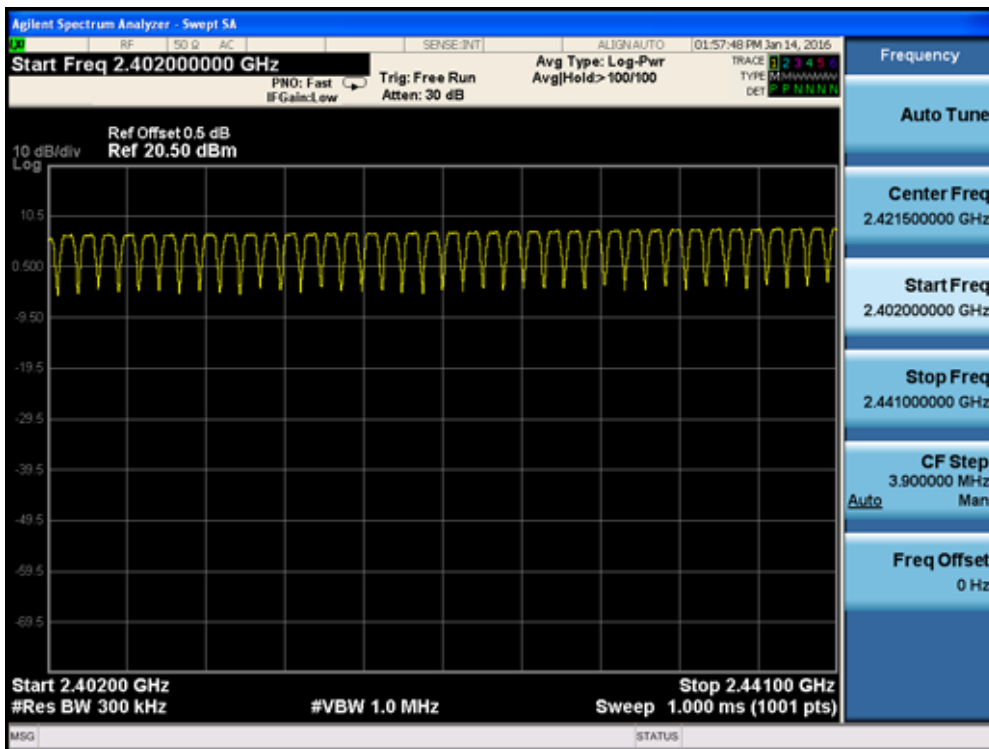

2442 - 2480 MHz

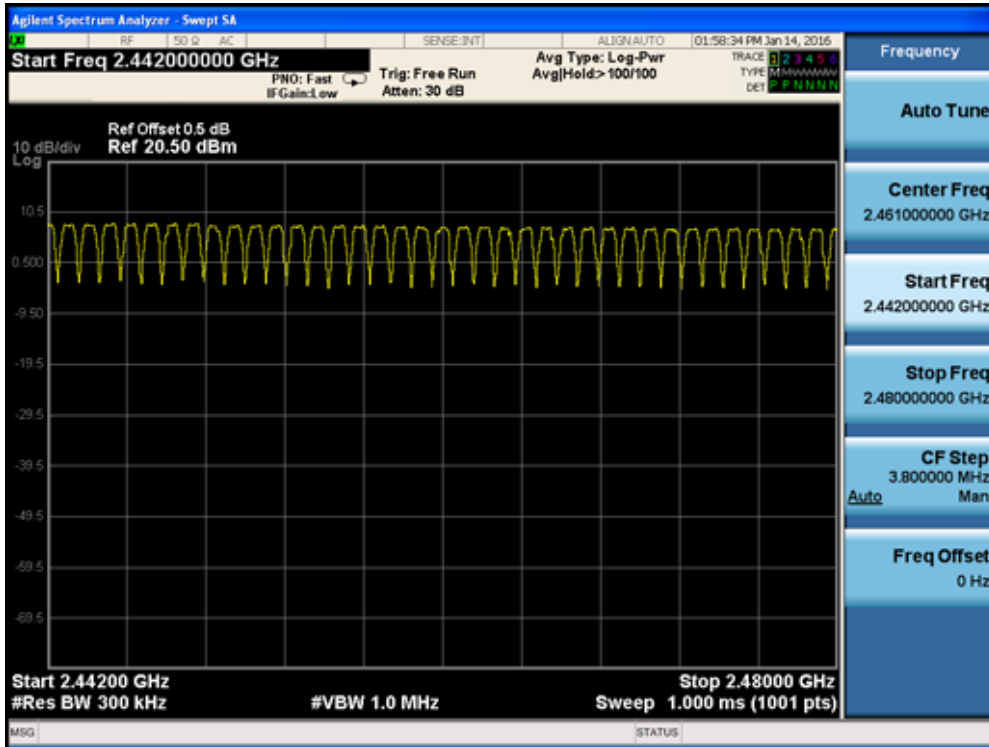

Product	:	Verve Ones/Verve Ones+
Test Item	:	Number of Hopping Frequencies
Test Site	:	TR-8
Test Mode	:	Mode 2: Transmitter-2Mbps (Pi/4 DQPSK_DH5)

Frequency Band (MHz)	Number of Hopping Frequencies	Limit	Result
2400 - 2483.5	79	>15	Pass

2402 - 2441 MHz

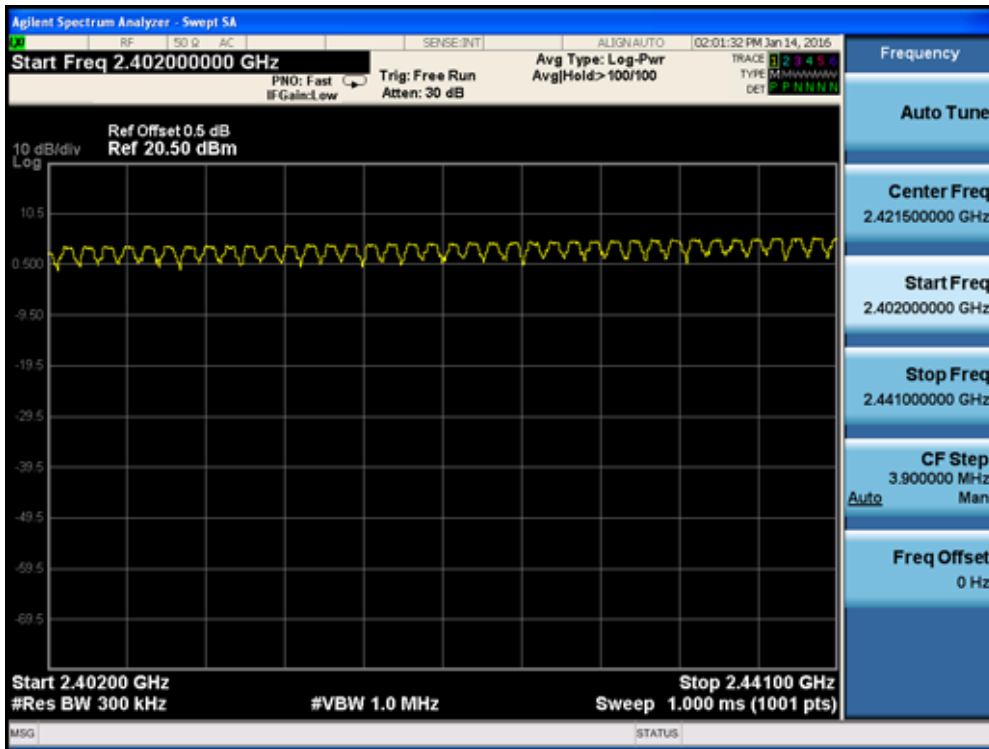

2442 - 2480 MHz

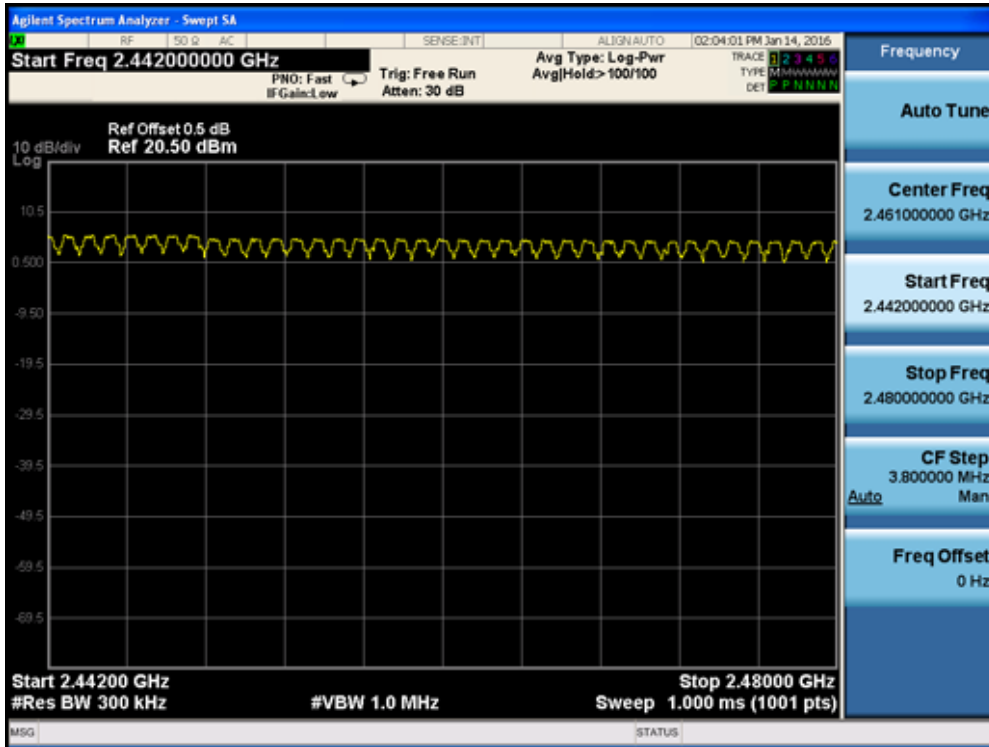

Product	:	Verve Ones/Verve Ones+
Test Item	:	Number of Hopping Frequencies
Test Site	:	TR-8
Test Mode	:	Mode 3: Transmitter-3Mbps (8DPSK_DH5)

Frequency Band (MHz)	Number of Hopping Frequencies	Limit	Result
2400 - 2483.5	79	>15	Pass

2402 - 2441 MHz

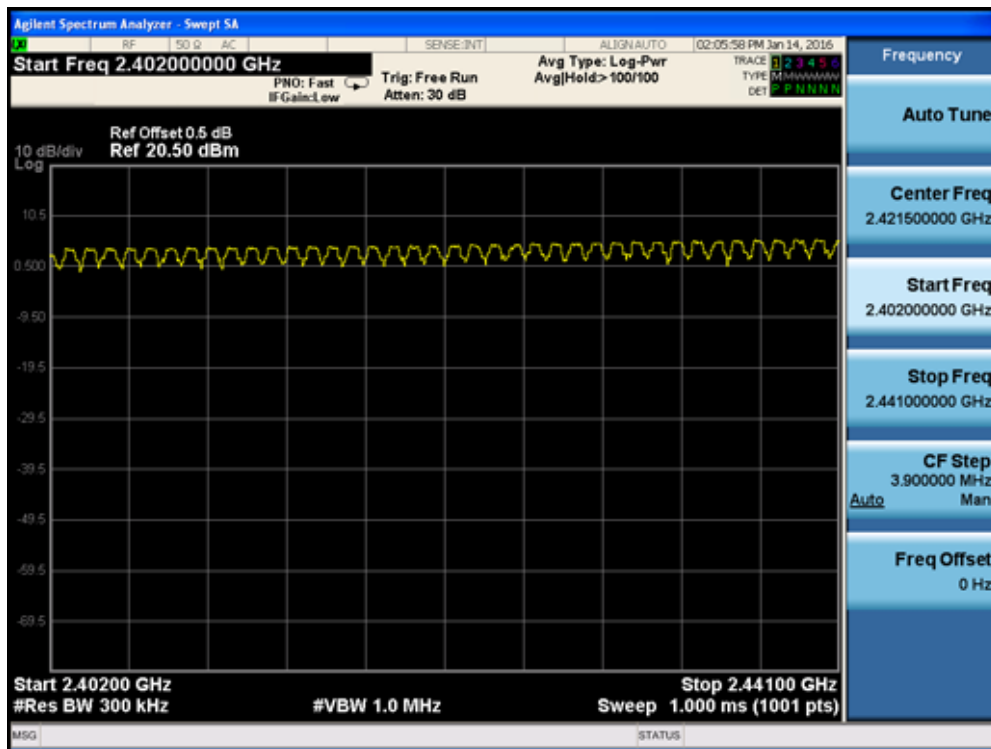

2442 - 2480 MHz

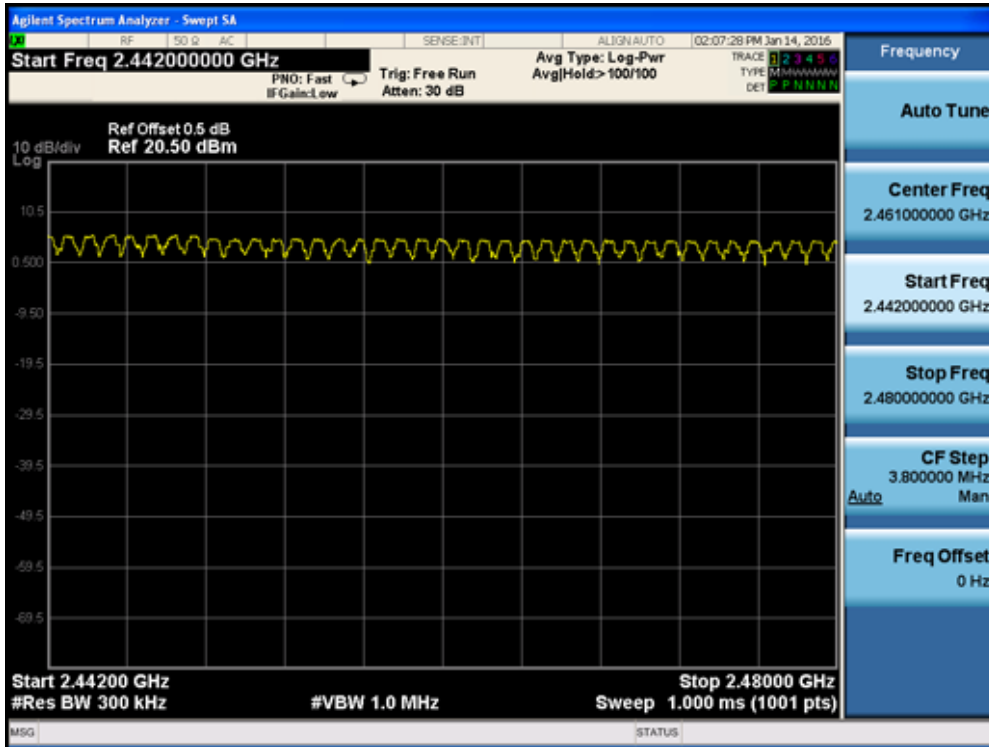

8. Time of Occupancy (Dwell Time)

8.1. Test Equipment

Time of Occupancy (Dwell Time) / TR-8

Instrument	Manufacturer	Type No.	Serial No.	Cal. Due Date
Spectrum Analyzer	Agilent	N9010A	MY48030494	2016.03.10
Temperature/Humidity Meter	Zhicheng	ZC1-2	TR8-TH	2016.04.09

Note: All equipments are calibrated with traceable calibrations. Each calibration is traceable to the national or international standards.

8.2. Test Setup

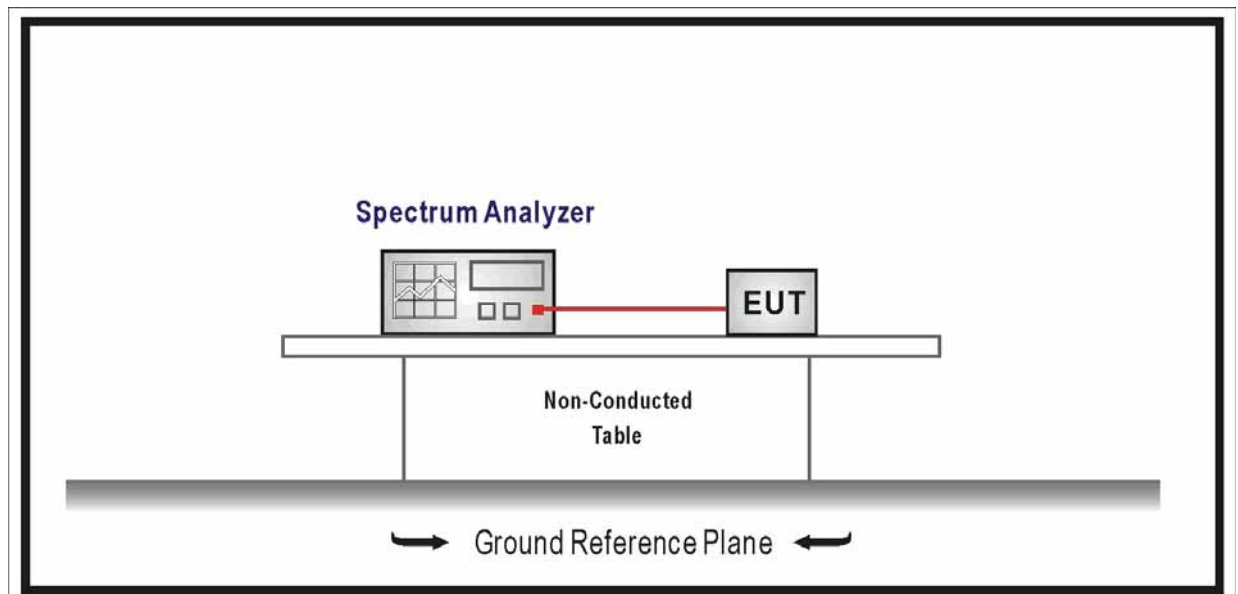

8.3. Limit

- For frequency hopping systems operating in the 902-928 MHz band: if the 20 dB bandwidth of the hopping channel is less than 250 kHz, the system shall use at least 50 hopping frequencies and the average time of occupancy on any frequency shall not be greater than 0.4 seconds within a 20 second period; If the 20 dB bandwidth of the hopping channel is 250 kHz or greater, the system shall use at least 25 hopping frequencies and the average time of occupancy on any frequency shall not be greater than 0.4 seconds within a 10 second period. The maximum allowed 20 dB bandwidth of the hopping channel is 500 kHz.
- Frequency hopping systems operating in the 5725-5850 MHz band shall use at least 75

hopping frequencies. The maximum 20 dB bandwidth of the hopping channel is 1 MHz. The average time of occupancy on any frequency shall not be greater than 0.4 seconds within a 30 second period.

- Frequency hopping systems in the 2400-2483.5 MHz band shall use at least 15 channels. The average time of occupancy on any channel shall not be greater than 0.4 seconds within a period of 0.4 seconds multiplied by the number of hopping channels employed. Frequency hopping systems may avoid or suppress transmissions on a particular hopping frequency provided that a minimum of 15 channels are used.

8.4. Test Procedure

According to ANSI C63.10: 2013& ANSI C63.4: 2014

The EUT must have its hopping function enabled. Use the following spectrum analyzer settings:

Span = zero span, centered on a hopping channel

RBW = 1MHz

VBW \geq RBW

Sweep = as necessary to capture the entire dwell time per hopping channel

Detector function = peak

Trace = max hold

If possible, use the marker-delta function to determine the dwell time. If this value varies with different modes of operation (e.g., data rate, modulation format, etc.), repeat this test for each variation.

8.5. Uncertainty

The measurement uncertainty is defined as ± 0.1 us

8.6. Test Result

Product	:	Verve Ones/Verve Ones+
Test Item	:	Time of Occupancy (Dwell Time)
Test Site	:	TR-8
Test Mode	:	Transmitter-1Mbps (GFSK_DH1)

Channel No.	Frequency (MHz)	Time of Occupancy (ms)	Limit (ms)	Result
39	2441	126.036	< 400	Pass

Test Time Period: $0.4 \times 79 = 31.6$ sec.

- 2441MHz, The Maximum Occupancy Time Within 31.6sec: $0.389\text{ms} \times 324 = 126.036\text{msec}$

Channel 39 (2441MHz)-(DH1)

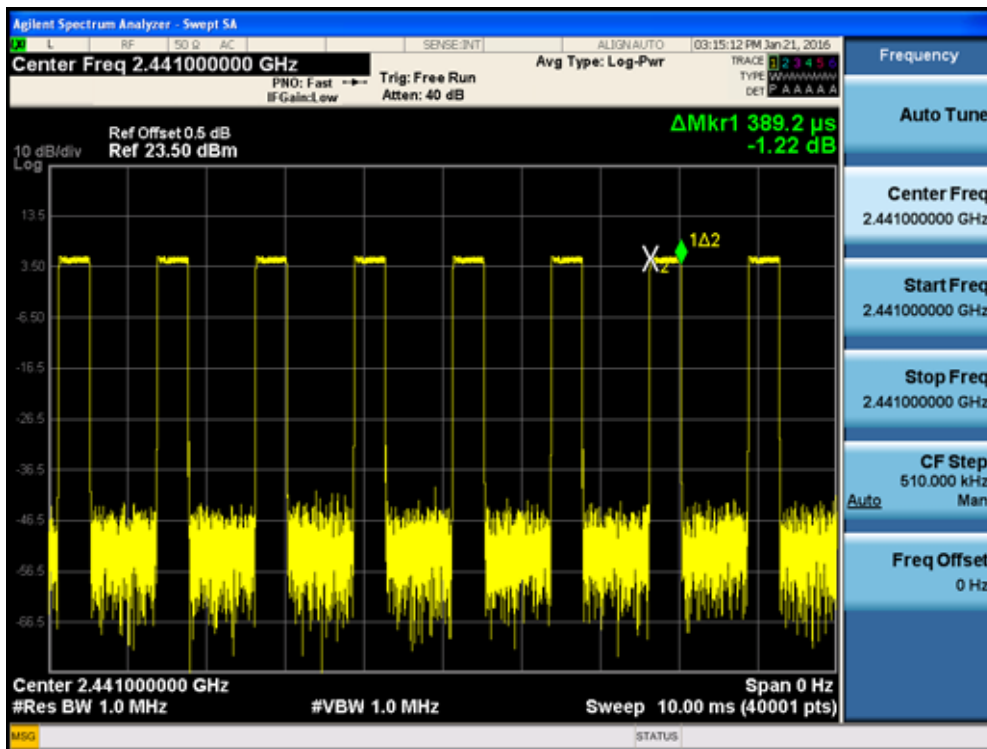

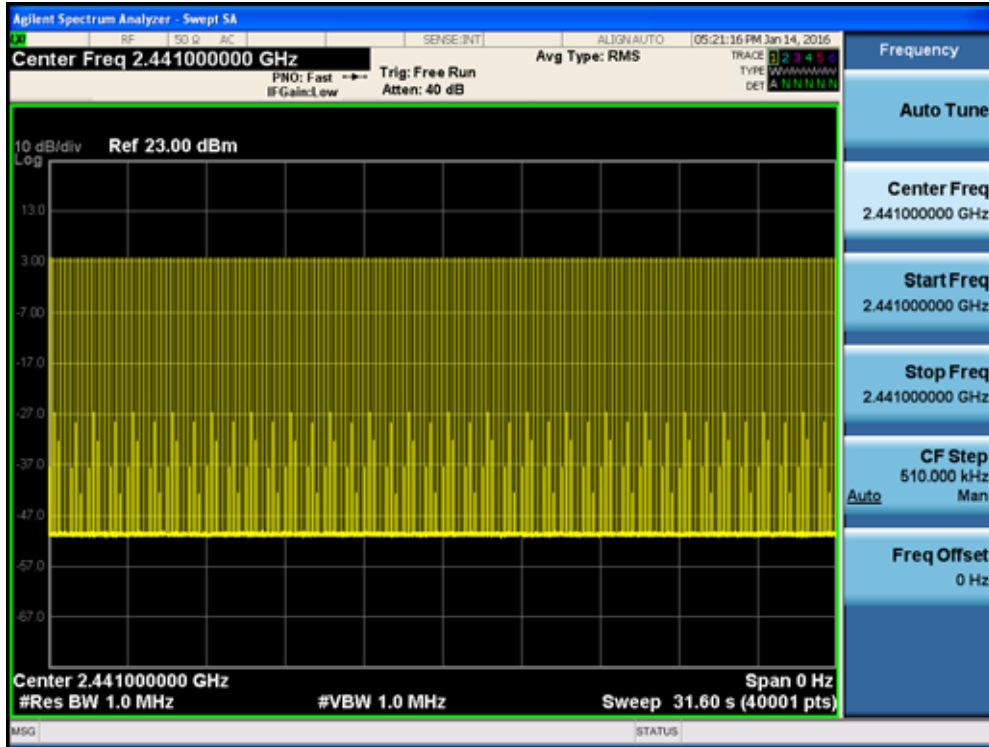

Product	: Verve Ones/Verve Ones+
Test Item	: Time of Occupancy (Dwell Time)
Test Site	: TR-8
Test Mode	: Transmitter-1Mbps (GFSK_DH3)

Channel No.	Frequency (MHz)	Time of Occupancy (ms)	Limit (ms)	Result
39	2441	175.801	< 400	Pass

Test Time Period: $0.4 \times 79 = 31.6$ sec.

- 2441MHz, The Maximum Occupancy Time Within 31.6sec: $1.643\text{ms} \times 107 = 175.801\text{msec}$

Channel 39 (2441MHz) - (DH3)

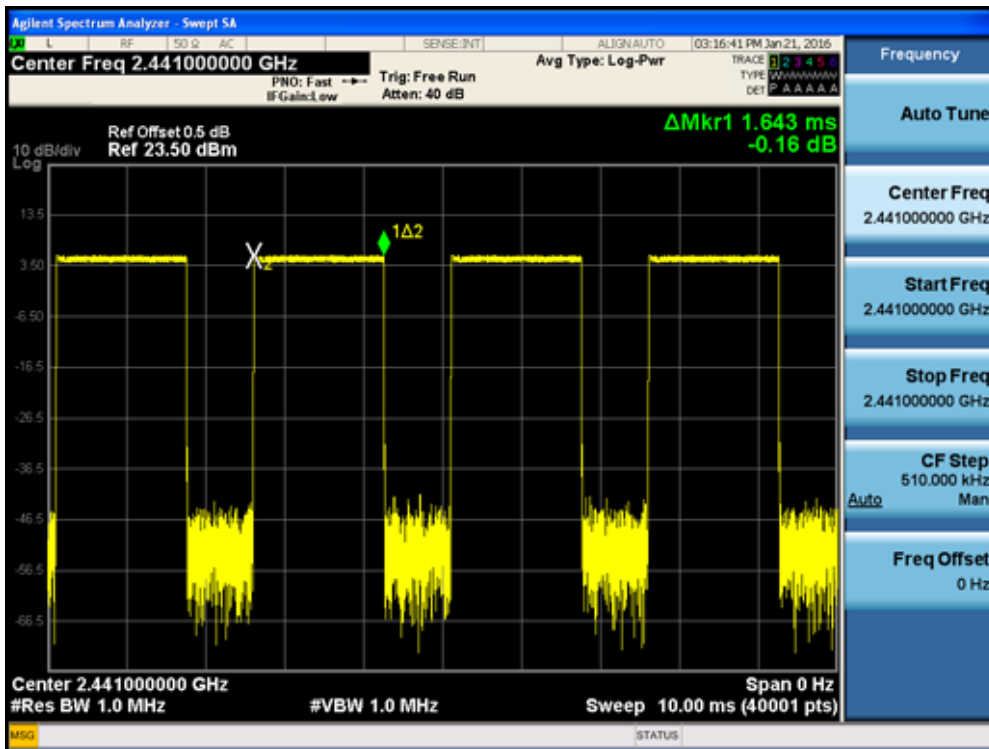

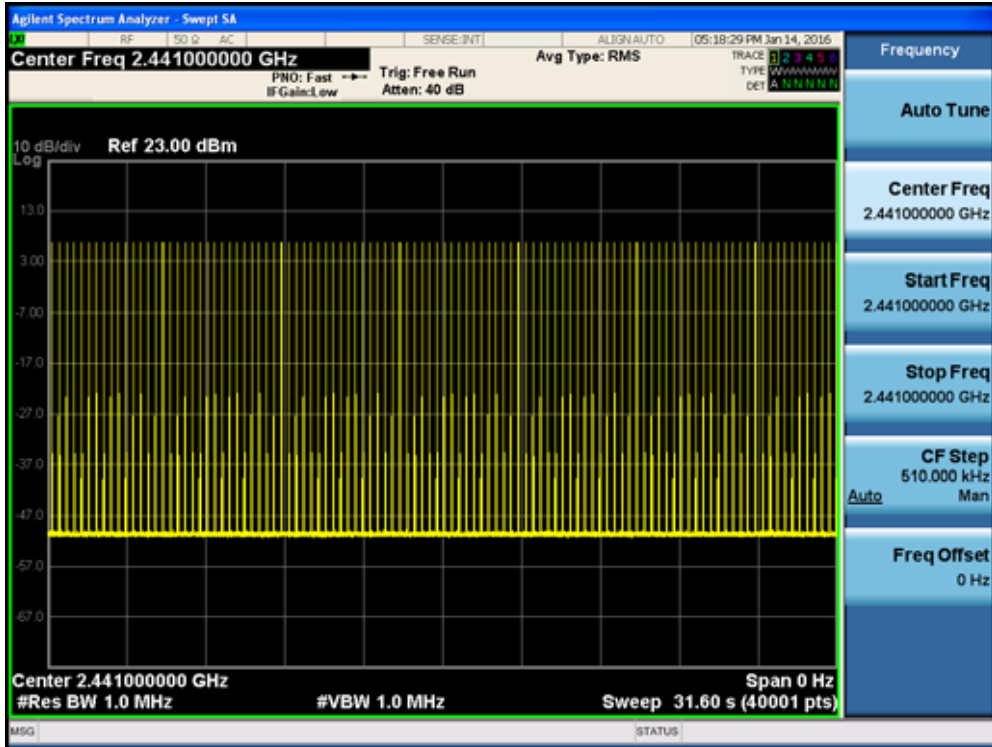

Product	:	Verve Ones/Verve Ones+
Test Item	:	Time of Occupancy (Dwell Time)
Test Site	:	TR-8
Test Mode	:	Transmitter-1Mbps (GFSK_DH5)

Channel No.	Frequency (MHz)	Time of Occupancy (ms)	Limit (ms)	Result
39	2441	306.340	< 400	Pass

Test Time Period: $0.4 \times 79 = 31.6$ sec.

- 2441MHz, The Maximum Occupancy Time Within 31.6sec: $2.890\text{ms} \times 106 = 306.340\text{msec}$

Channel 39 (2441MHz) - (DH5)

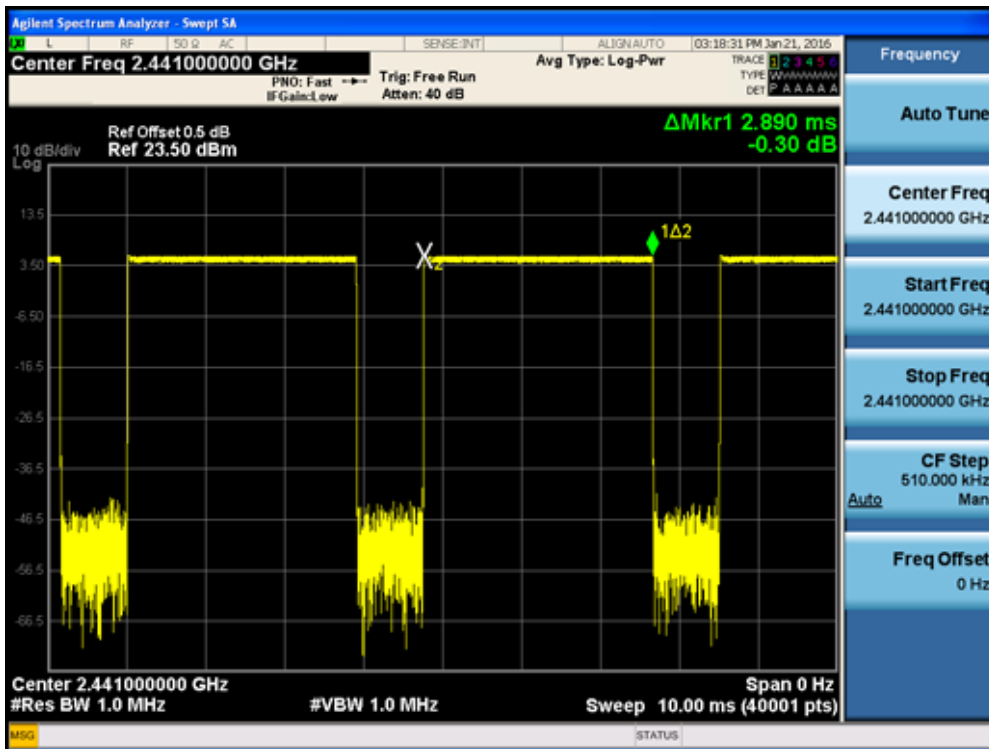

9. Peak Output Power

9.1. Test Equipment

Peak Output Power / TR-8

Instrument	Manufacturer	Type No.	Serial No.	Cal. Due Date
Spectrum Analyzer	Agilent	N9010A	MY48030494	2016.03.10
Temperature/Humidity Meter	Zhicheng	ZC1-2	TR8-TH	2016.04.09

Note: All equipments are calibrated with traceable calibrations. Each calibration is traceable to the national or international standards.

9.2. Test Setup

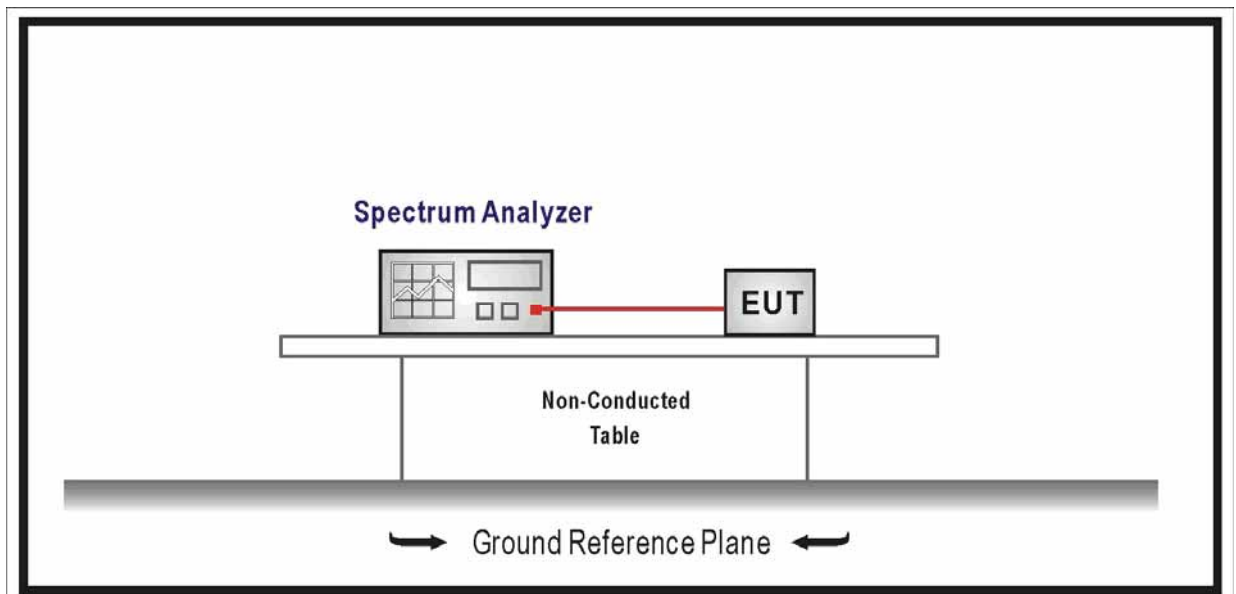

9.3. Limit

- For frequency hopping systems operating in the 2400-2483.5 MHz band employing at least 75 non-overlapping hopping channels, and all frequency hopping systems in the 5725-5850 MHz band: 1 watt. For all other frequency hopping systems in the 2400-2483.5 MHz band: 0.125 watts.
- For frequency hopping systems operating in the 902-928 MHz band: 1 watt for systems employing at least 50 hopping channels; and, 0.25 watts for systems employing less than 50 hopping channels, but at least 25 hopping channels.

Note: the conducted output power limit specified above is based on the use the antennas with

directional gains that do not exceed 6 dBi are used, the conducted output power from the intentional radiator shall be reduced below the stated values above, as appropriate, by the amount in dB that the directional gain of antenna exceeds 6 dBi.

9.4. Test Procedure

According to ANSI C63.10: 2013& ANSI C63.4: 2014

Use the following spectrum analyzer settings:

Span = approximately 5 times the 20dB bandwidth, centered on a hopping channel

RBW > the 20 dB bandwidth of the emission being measured.

VBW \cong RBW

Sweep = auto

Detector function = peak

Trace = max hold

Allow the trace to stabilize. Use the marker-to-peak function to set the marker to the peak of the emission. The indicated level is the peak output power (don't forget added the external attenuation and cable loss).

9.5. Uncertainty

The measurement uncertainty is defined as ± 1.0 dB

9.6. Test Result

Product	:	Verve Ones/Verve Ones+
Test Item	:	Power Output
Test Site	:	TR-8
Test Mode	:	Mode 1: Transmitter-1Mbps (GFSK_DH5)

Channel No.	Frequency (MHz)	Measurement Power Output (dBm)	Limit (dBm)	Result
0	2402	7.98	30.00	Pass
39	2441	8.94	30.00	Pass
78	2480	9.02	30.00	Pass

DH5 2402MHz

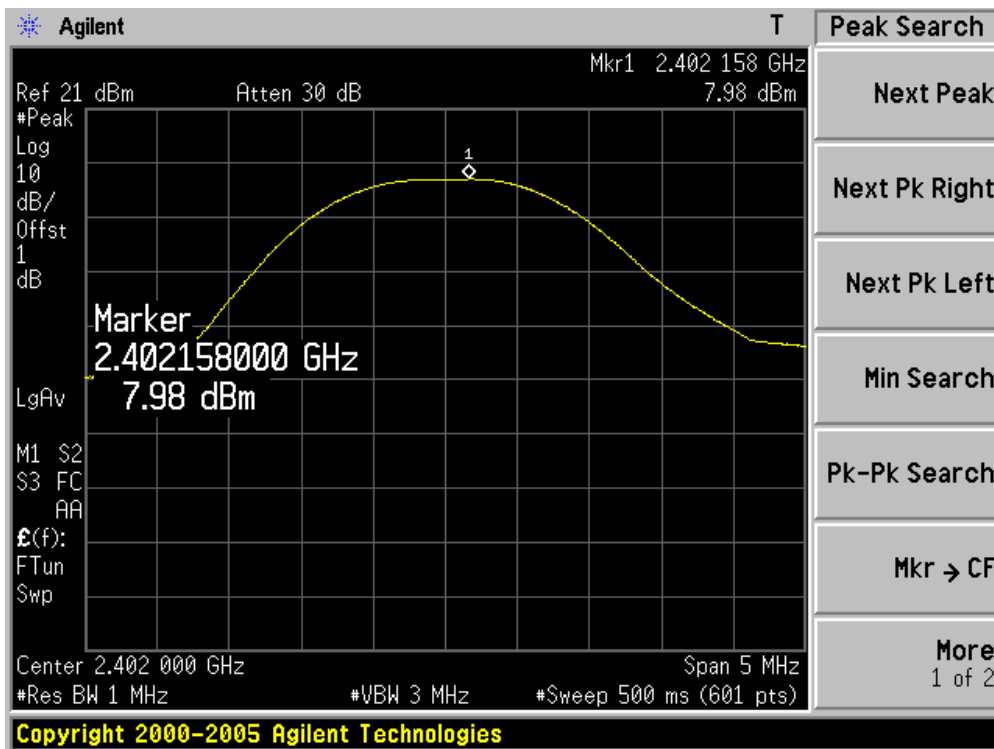

DH5 2441MHz

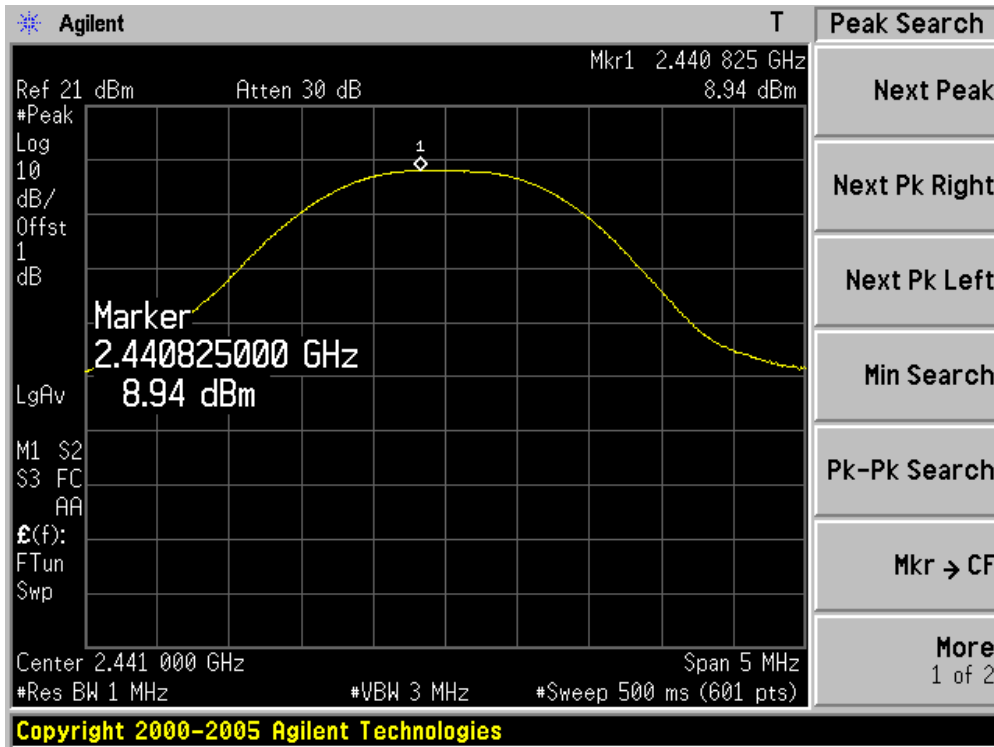

DH5 2480MHz

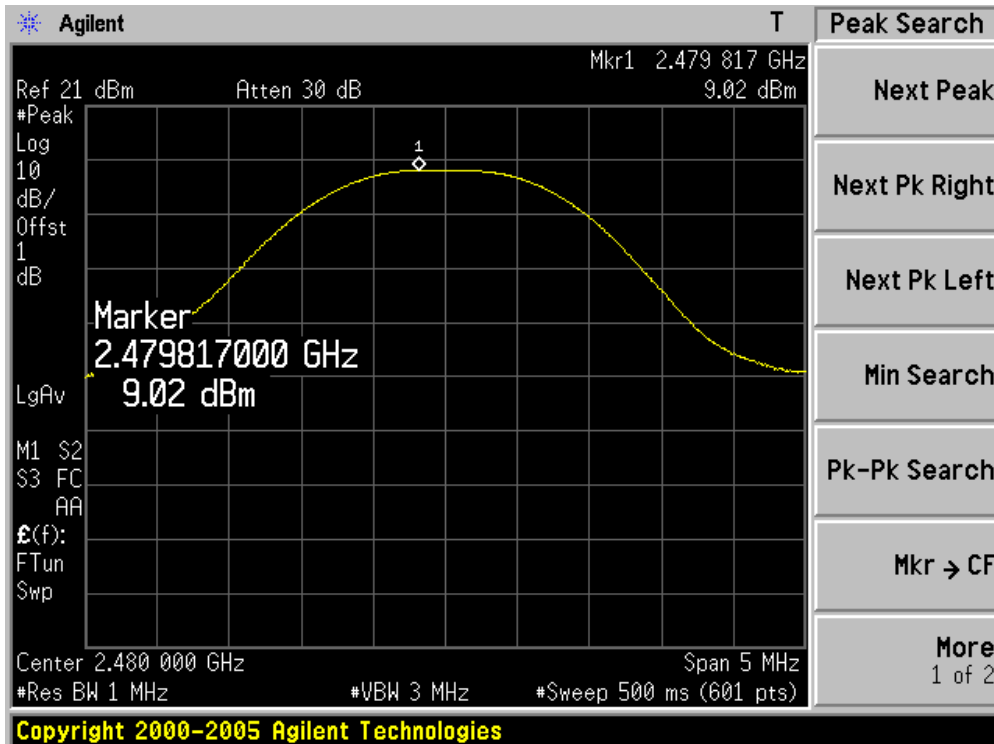

Product	: Verve Ones/Verve Ones+
Test Item	: Power Output
Test Site	: TR-8
Test Mode	: Mode 2: Transmitter-2Mbps (Pi/4 DQPSK_DH5)

Channel No.	Frequency (MHz)	Measurement Power Output (dBm)	Limit (dBm)	Result
0	2402	6.32	30.00	Pass
39	2441	7.80	30.00	Pass
78	2480	8.03	30.00	Pass

2DH5 2402MHz

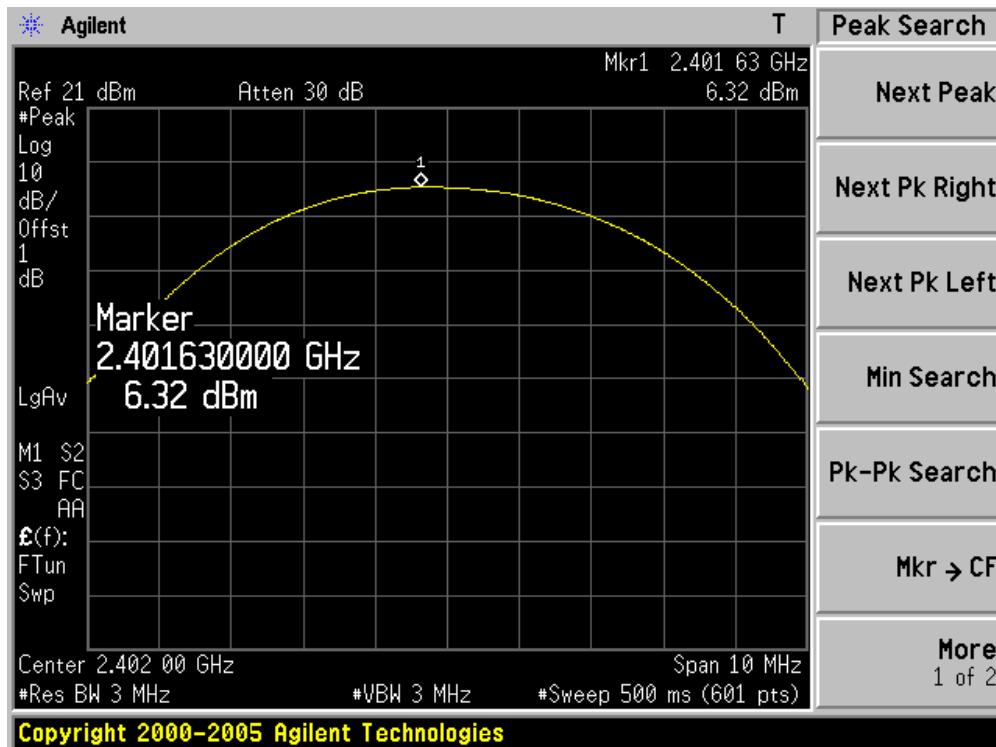

2DH5 2441MHz

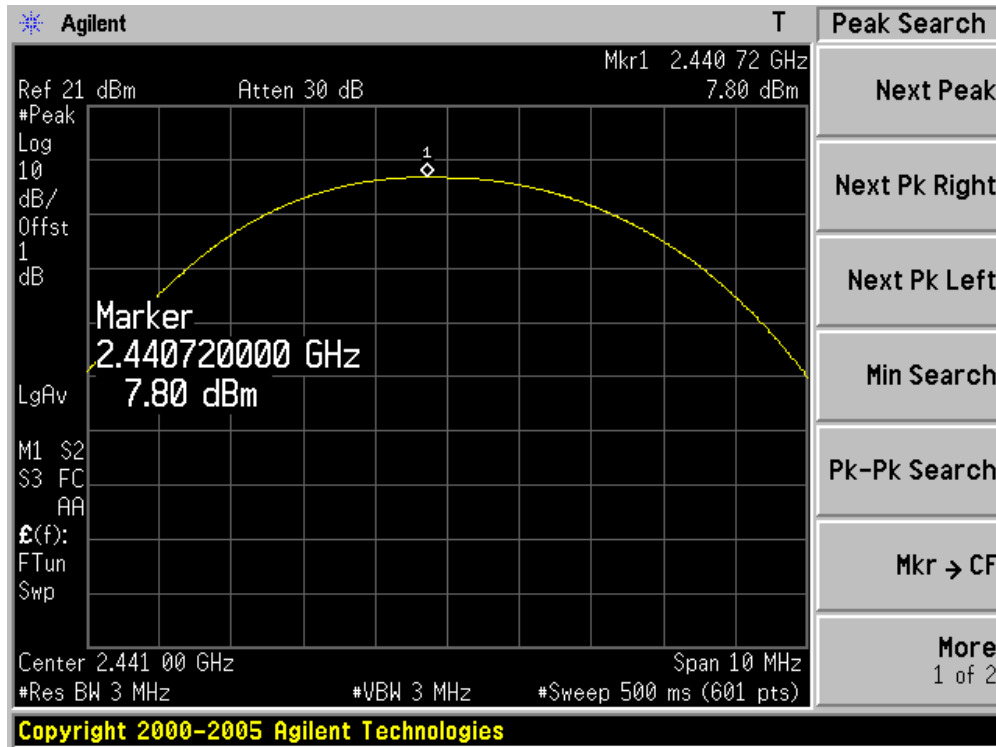

2DH5 2480MHz

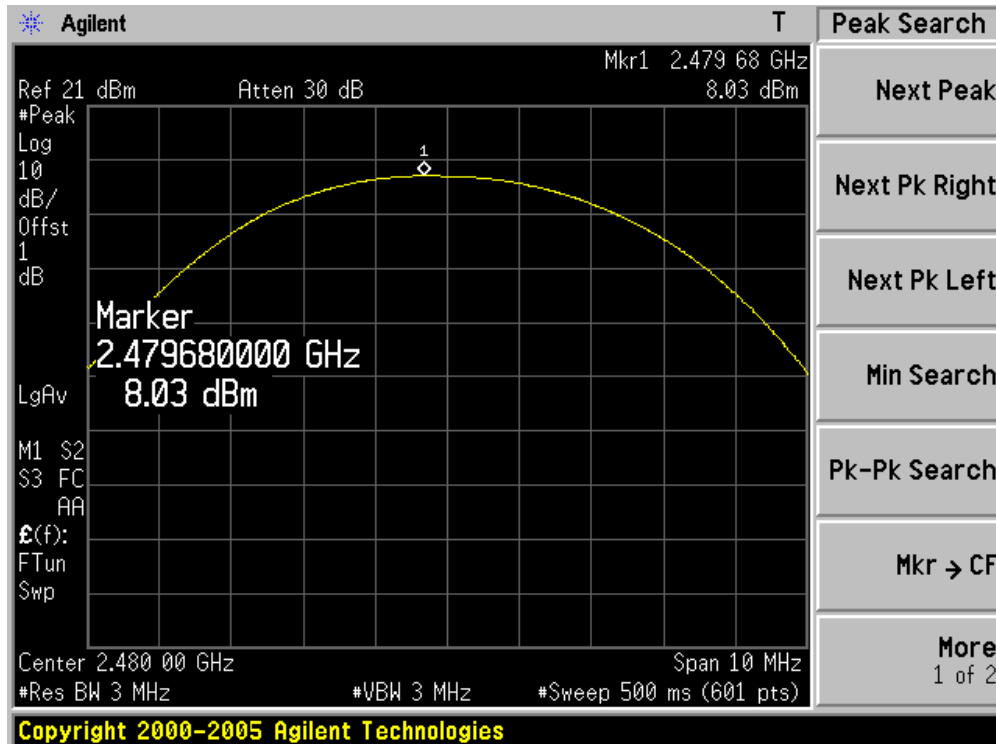

Product	: Verve Ones/Verve Ones+
Test Item	: Power Output
Test Site	: TR-8
Test Mode	: Mode 3: Transmitter-3Mbps (8DPSK_DH5)

Channel No.	Frequency (MHz)	Measurement Power Output (dBm)	Limit (dBm)	Result
0	2402	6.66	30.00	Pass
39	2441	8.06	30.00	Pass
78	2480	8.26	30.00	Pass

3DH5 2402MHz

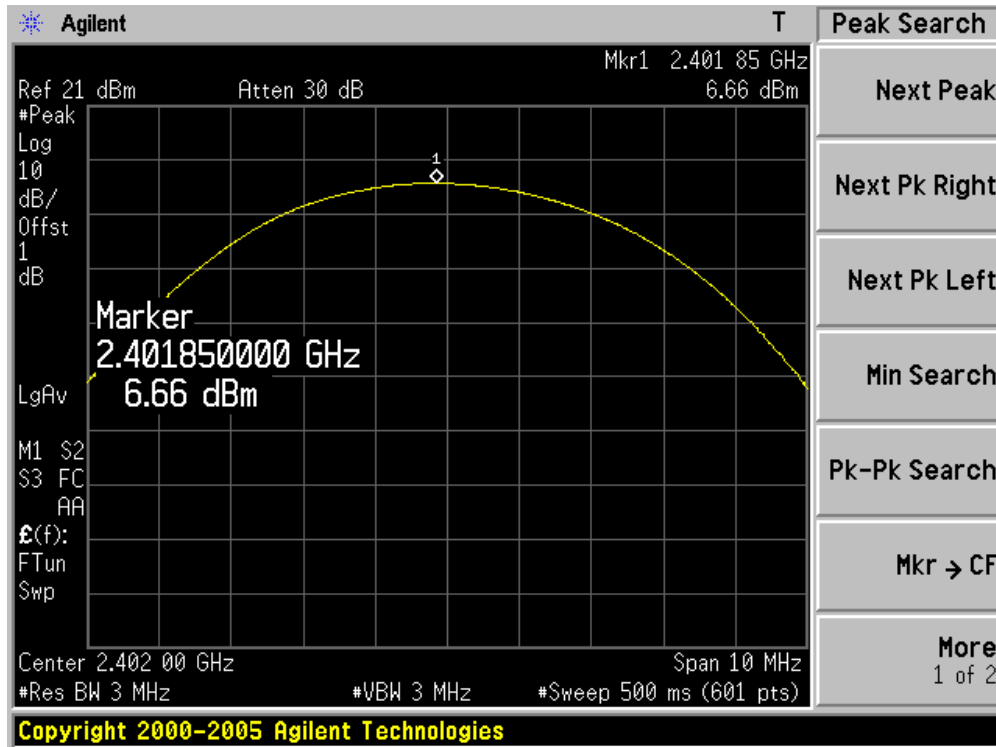

3DH5 2441MHz

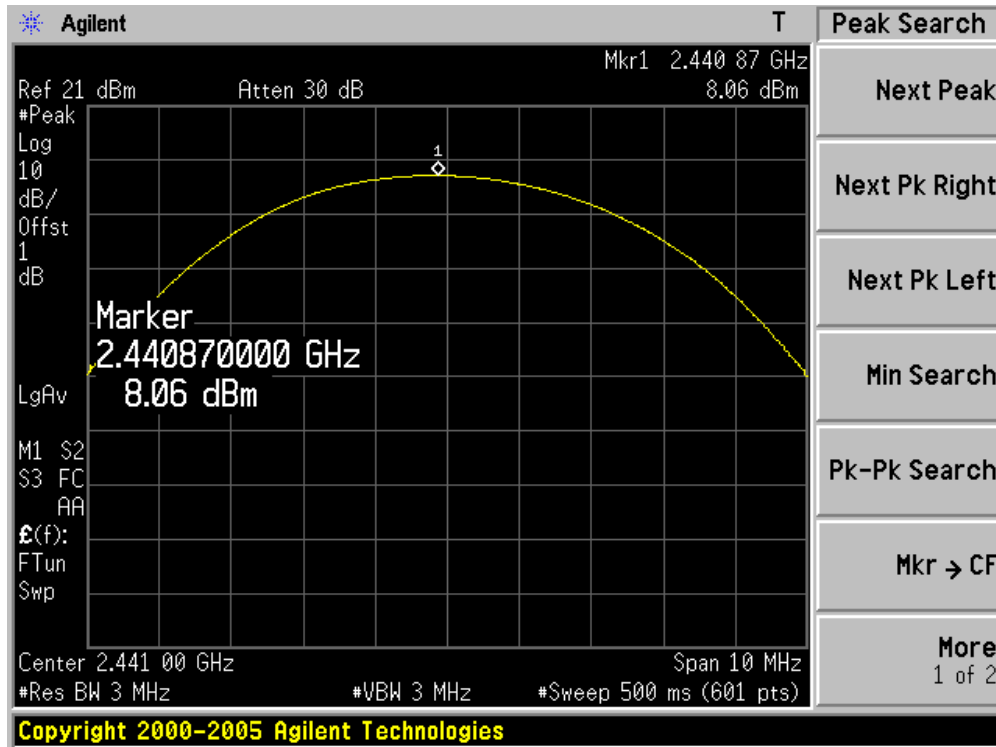

3DH5 2480MHz

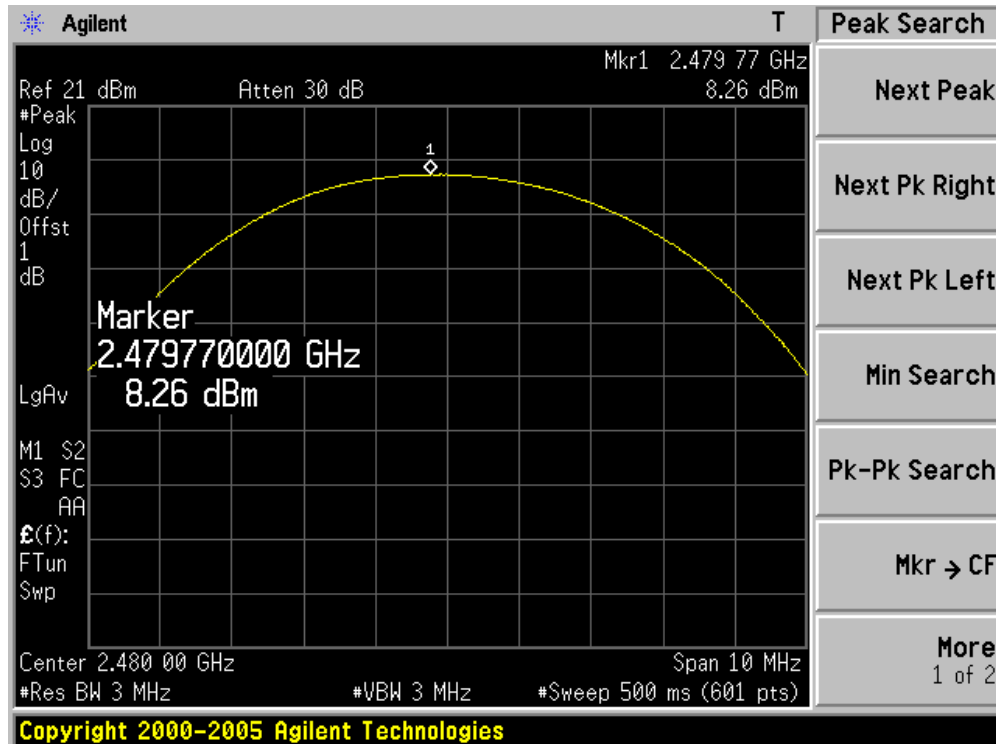

10. Band-edge Compliance of RF Conducted Emissions

10.1. Test Equipment

Band-edge Compliance of RF Conducted Emissions / TR-8

Instrument	Manufacturer	Type No.	Serial No.	Cal. Due Date
Spectrum Analyzer	Agilent	N9010A	MY48030494	2016.03.10
Temperature/Humidity Meter	Zhicheng	ZC1-2	TR8-TH	2016.04.09

Note: All equipments are calibrated with traceable calibrations. Each calibration is traceable to the national or international standards.

10.2. Test Setup

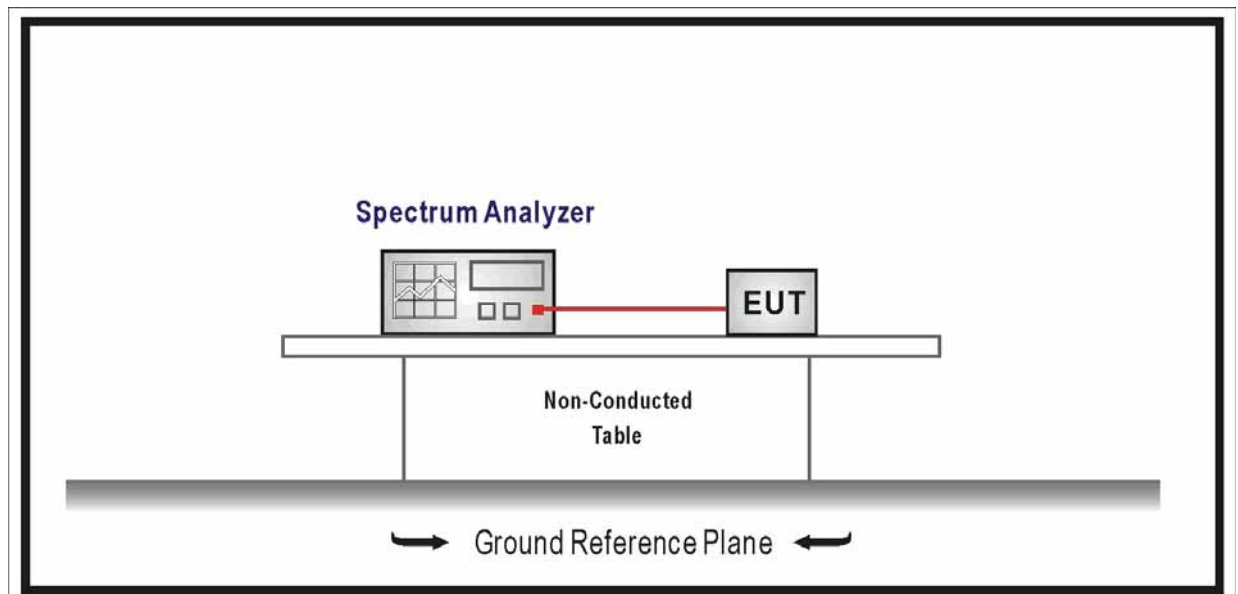

10.3. Limit

- Intentional radiators operating under the alternative provisions to the general emission limits as contained in 15.217 through 15.257 and in Subpart E of FCC part 15, must be designed to ensure that 20 dB bandwidth of the emission, or whatever bandwidth may otherwise be specified in the specific rule section under which the equipment operates, is contained within the frequency band designated in the rule section under which the equipment is operated.
- In any 100 kHz bandwidth outside the frequency band in which the spread spectrum or digitally modulated intentional radiator is operating, the radio frequency power that is produced by the intentional radiator shall be at least 20 dB below that in the 100 kHz

bandwidth within the band that contains the highest level of the desired power, based on either an RF conducted or a radiated measurement, provided the transmitter demonstrates compliance with the peak conducted or a radiated measurement, provided the transmitter demonstrates compliance with the peak conducted power limits. If the transmitter complies with the conducted power limits based on the use of RMS averaging over a time interval, the attenuation required under this paragraph shall be 30 dB instead of 20 dB. Attenuation below the general limits specified in Section 15.209(a) of FCC part 15 is not required.

10.4. Test Procedure

According to ANSI C63.10: 2013& ANSI C63.4: 2014

Use the following spectrum analyzer settings:

Span = wide enough to capture the peak level of the emission operating on the channel closest to the bandedge, as well as any modulation products which fall outside of the authorized band of operation.

RBW \cong 1% of the span

VBW \cong RBW

Sweep = auto

Detector function = peak

Trace = max hold

Allow the trace to stabilize. Set the marker on the emission at the bandedge, or on the highest modulation product outside of the band, if this level is greater than that at the bandedge.

Enable the marker-delta function, then use the marker-to-peak function to move the marker to the peak of the in-band emission. The marker-delta value now displayed must comply with the limit specified in this Section.

Now, using the same instrument settings, enable the hopping function of the EUT. Allow the trace to stabilize. Follow the same procedure listed above to determine if any spurious emissions caused by the hopping function also comply with the specified limit.

10.5. Uncertainty

The measurement uncertainty is defined as ± 1.0 dB

10.6. Test Result

Product	:	Verve Ones/Verve Ones+
Test Item	:	Band-edge Compliance of RF Conducted Emissions
Test Site	:	TR-8
Test Mode	:	Mode 1: Transmitter-1Mbps (GFSK_DH5)

Channel 00 (2402MHz)



Channel 78 (2480MHz)



Product	: Verve Ones/Verve Ones+
Test Item	: Band-edge Compliance of RF Conducted Emissions
Test Site	: TR-8
Test Mode	: Mode 2: Transmitter-2Mbps (Pi/4 DQPSK_DH5)

Channel 00 (2402MHz)

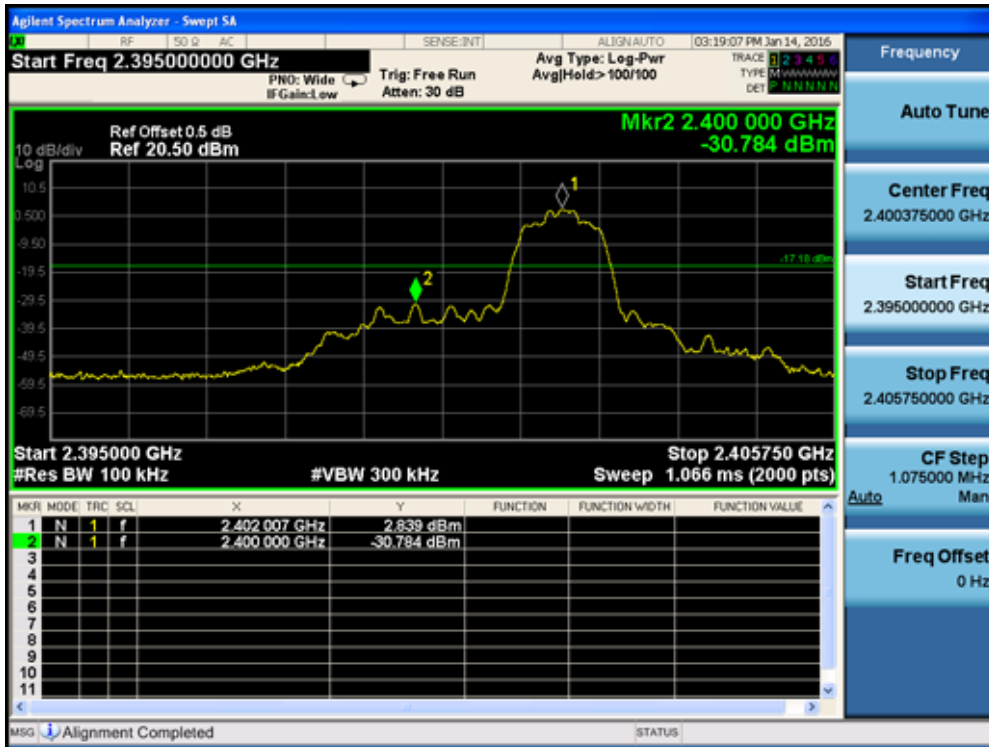

Channel 78 (2480MHz)



Product	: Verve Ones/Verve Ones+
Test Item	: Band-edge Compliance of RF Conducted Emissions
Test Site	: TR-8
Test Mode	: Mode 3: Transmitter-3Mbps (8DPSK_DH5)

Channel 00 (2402MHz)



Channel 78 (2480MHz)

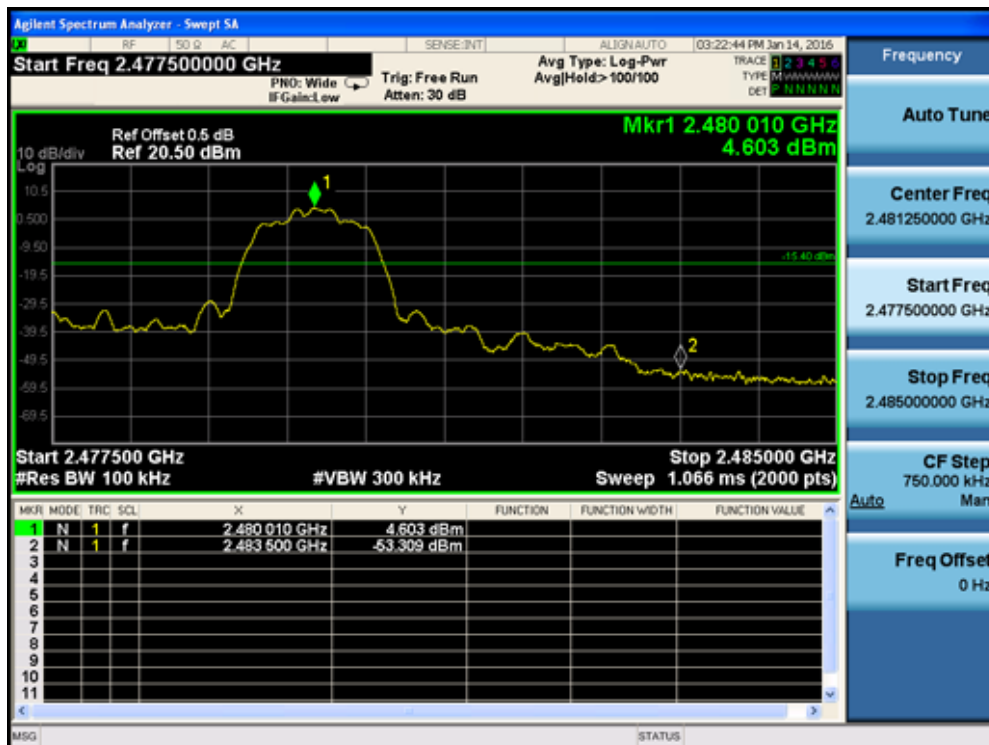

Product	: Verve Ones/Verve Ones+
Test Item	: Band-edge Compliance of RF Conducted Emissions
Test Site	: TR-8
Test Mode	: Mode: Hopping Mode

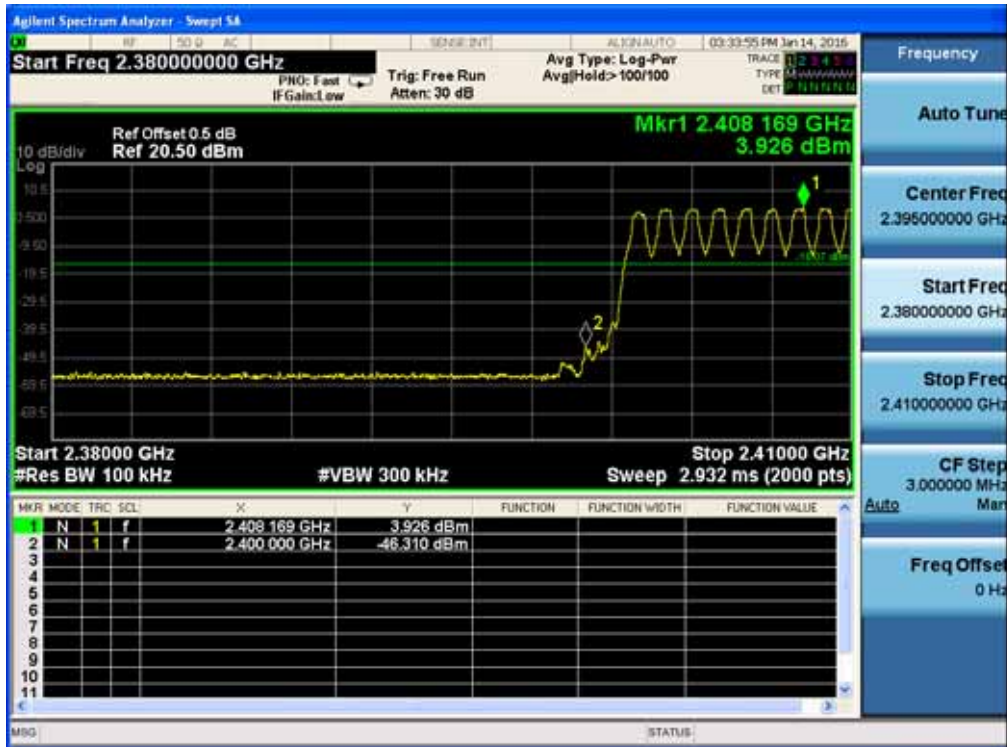

11. Spurious RF Conducted Emissions

11.1. Test Equipment

Spurious RF Conducted Emissions / TR-8

Instrument	Manufacturer	Type No.	Serial No.	Cal. Due Date
Spectrum Analyzer	Agilent	N9010A	MY48030494	2016.03.10
Temperature/Humidity Meter	Zhicheng	ZC1-2	TR8-TH	2016.04.09

Note: All equipments are calibrated with traceable calibrations. Each calibration is traceable to the national or international standards.

11.2. Test Setup

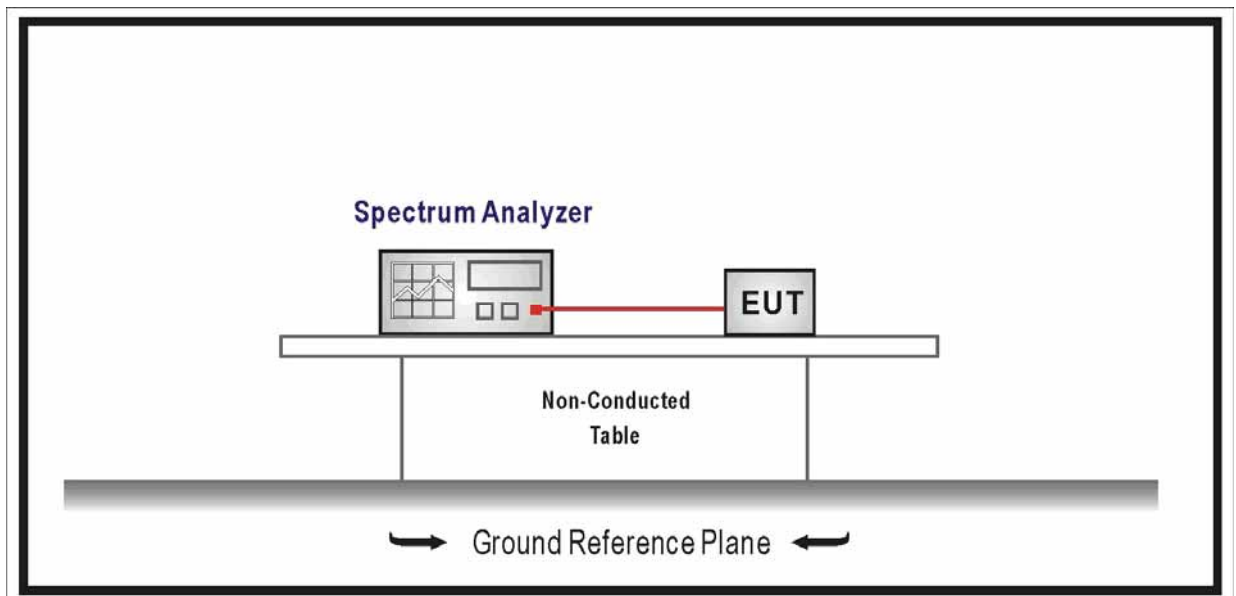

11.3. Limit

In any 100 kHz bandwidth outside the frequency band in which the spread spectrum or digitally modulated intentional radiator is operating, the radio frequency power that is produced by the intentional radiator shall be at least 20 dB below that in the 100 kHz bandwidth within the band that contains the highest level of the desired power, based on either an RF conducted or a radiated measurement, provided the transmitter demonstrates compliance with the peak conducted or a radiated measurement, provided the transmitter demonstrates compliance with the peak conducted power limits. If the transmitter complies with the conducted power limits based on the use of RMS averaging over a time interval, the attenuation required under this paragraph shall be 30 dB instead of 20 dB. Attenuation below the general limits specified in

Section 15.209(a) of FCC part 15 is not required.

11.4. Test Procedure

According to ANSI C63.10: 2013.

Use the following spectrum analyzer settings:

Span = wide enough to capture the peak level of the in-band emission and all spurious emissions (e.g., harmonics) from the lowest frequency generated in the EUT up through the 10th harmonic. Typically, several plots are required to cover this entire span.

RBW = 100 kHz

VBW \cong RBW

Sweep = auto

Detector function = peak

Trace = max hold

Allow the trace to stabilize. Set the marker on the peak of any spurious emission recorded.

The level displayed must comply with the limit specified in this section.

11.5. Uncertainty

The measurement uncertainty is defined as ± 1.0 dB

11.6. Test Result

Product	: Verve Ones/Verve Ones+
Test Item	: Spurious RF Conducted Emissions
Test Site	: TR-8
Test Mode	: Mode 1: Transmitter-1Mbps (GFSK_DH5)

Channel 00 (2402MHz)

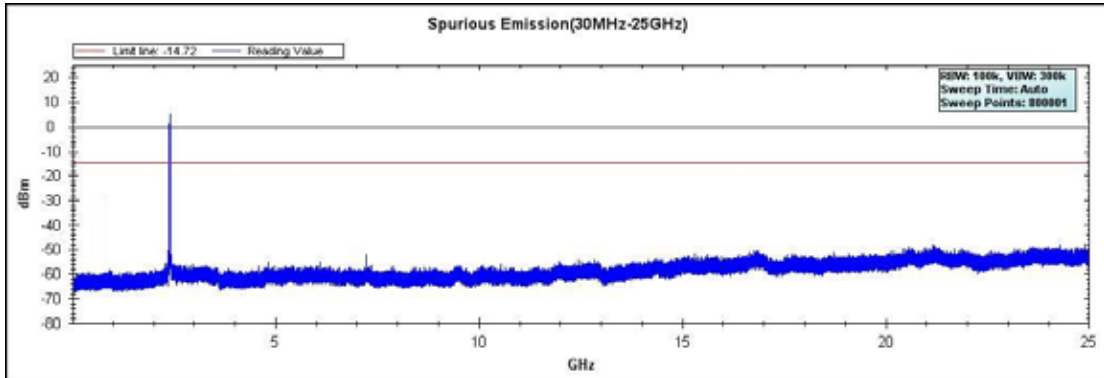

Note: The above test pattern is synthesized by multiple of the frequency range.

Channel 39 (2441MHz)

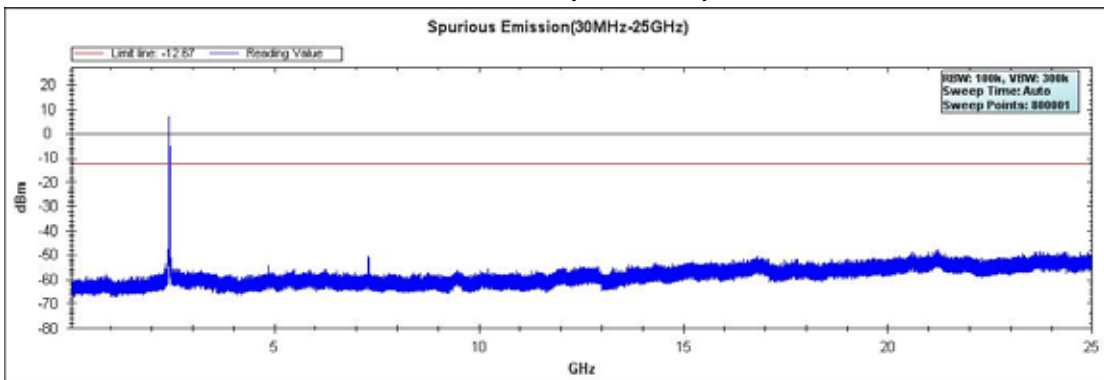

Note: The above test pattern is synthesized by multiple of the frequency range.

Channel 79 (2480MHz)

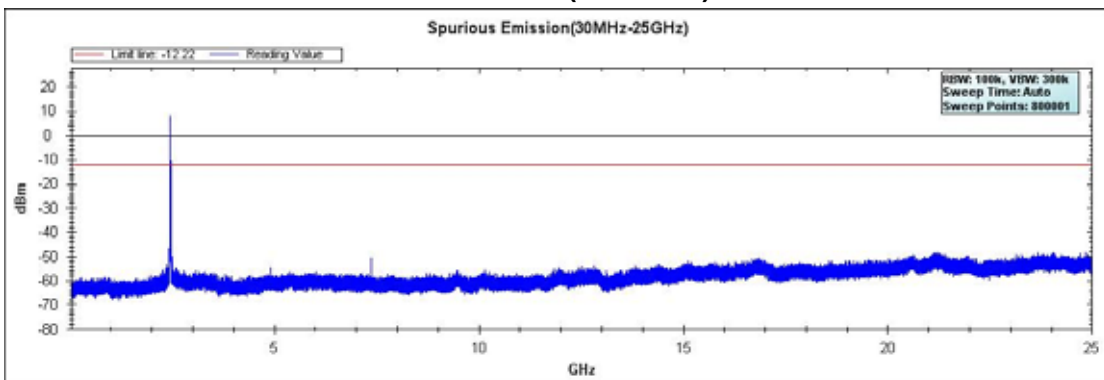

Note: The above test pattern is synthesized by multiple of the frequency range.

Product	: Verve Ones/Verve Ones+
Test Item	: Spurious RF Conducted Emissions
Test Site	: TR-8
Test Mode	: Mode 2: Transmitter-2Mbps (Pi/4 DQPSK_DH5)

Channel 00 (2402MHz)

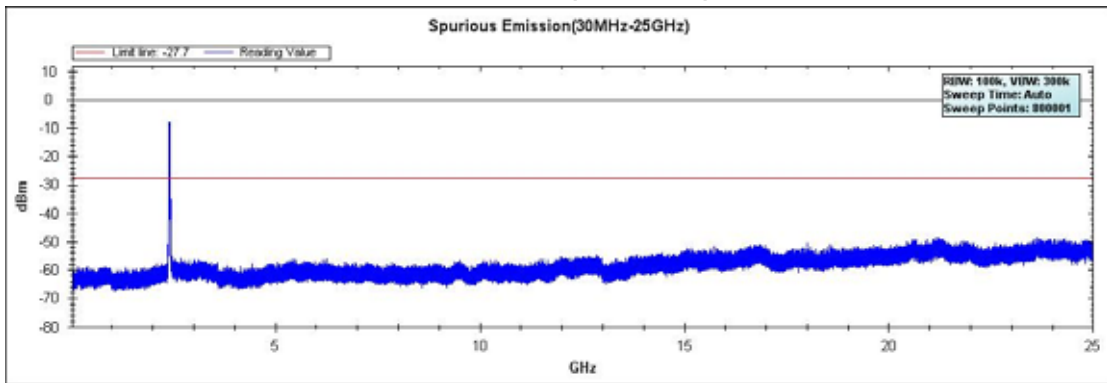

Note: The above test pattern is synthesized by multiple of the frequency range.

Channel 39 (2441MHz)

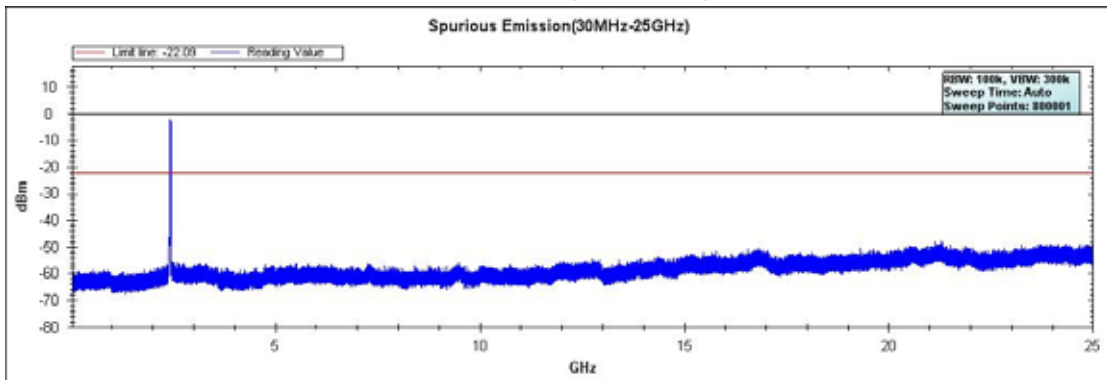

Note: The above test pattern is synthesized by multiple of the frequency range.

Channel 79 (2480MHz)

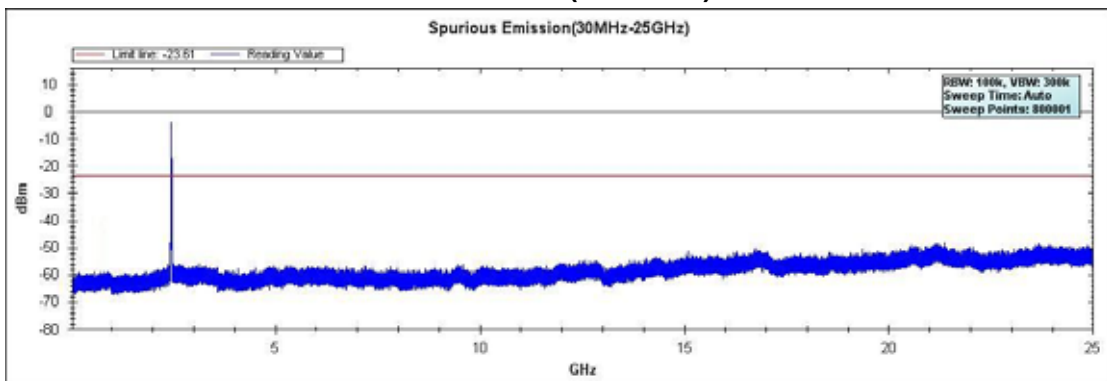

Note: The above test pattern is synthesized by multiple of the frequency range.

Product	:	Verve Ones/Verve Ones+
Test Item	:	Spurious RF Conducted Emissions
Test Site	:	TR-8
Test Mode	:	Mode 3: Transmitter-3Mbps (8DPSK_DH5)

Channel 00 (2402MHz)

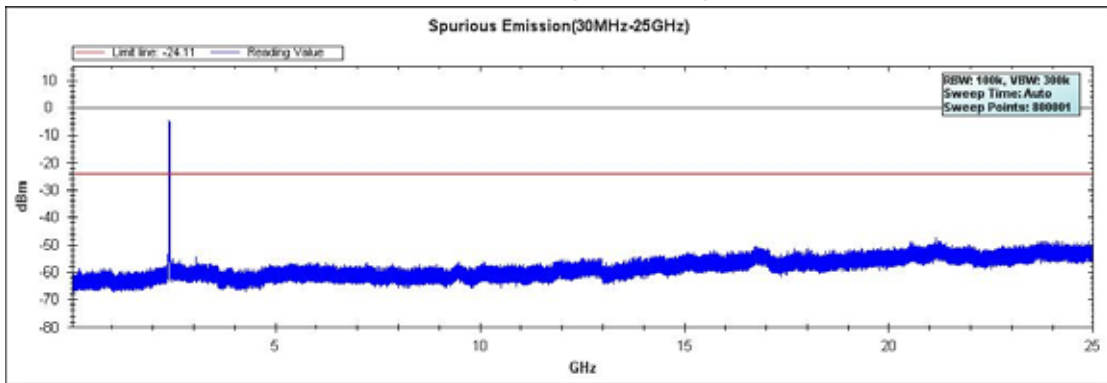

Note: The above test pattern is synthesized by multiple of the frequency range.

Channel 39 (2441MHz)

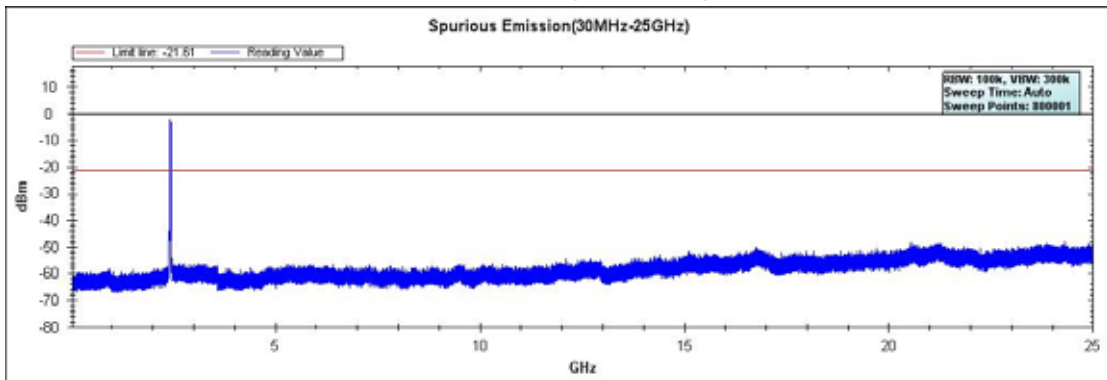

Note: The above test pattern is synthesized by multiple of the frequency range.

Channel 79 (2480MHz)

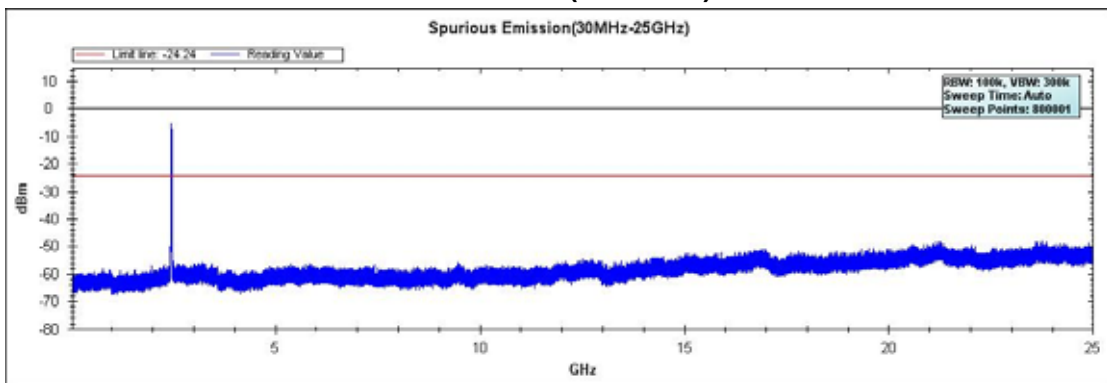

Note: The above test pattern is synthesized by multiple of the frequency range.

12. Radiated Emission Band Edge

12.1. Test Equipment

Radiated Emission Band Edge / AC-5

Instrument	Manufacturer	Type No.	Serial No.	Cal. Due Date
Spectrum Analyzer	Agilent	N9010A	MY48030494	2016.03.10
Preamplifier	Miteq	NSP1800-25	1364185	2016.05.03
Preamplifier	Quietek	AP-040G	CHM-0906001	2016.05.03
Bilog Antenna	Teseq GmbH	CBL6112D	27612	2016.10.15
Broad-Band Horn Antenna	Schwarzbeck	BBHA9120D	733	2016.02.26
DRG Horn	ETS-Lindgren	3117	00167055	2016.07.16
Broad-Band Horn Antenna	Schwarzbeck	BBHA9170	294	2016.03.01
Coaxial Cable	Huber+Suhner	SUCOFLEX 106	AC5-C1	2016.03.01
Coaxial Cable	Huber+Suhner	SUCOFLEX 106	AC5-C2	2016.03.01
Coaxial Cable	Huber+Suhner	SUCOFLEX 102	AC5-C3	2016.08.07
Temperature/Humidity Meter	Zhicheng	ZC1-2	AC5-TH	2017.01.07

12.2. Test Setup

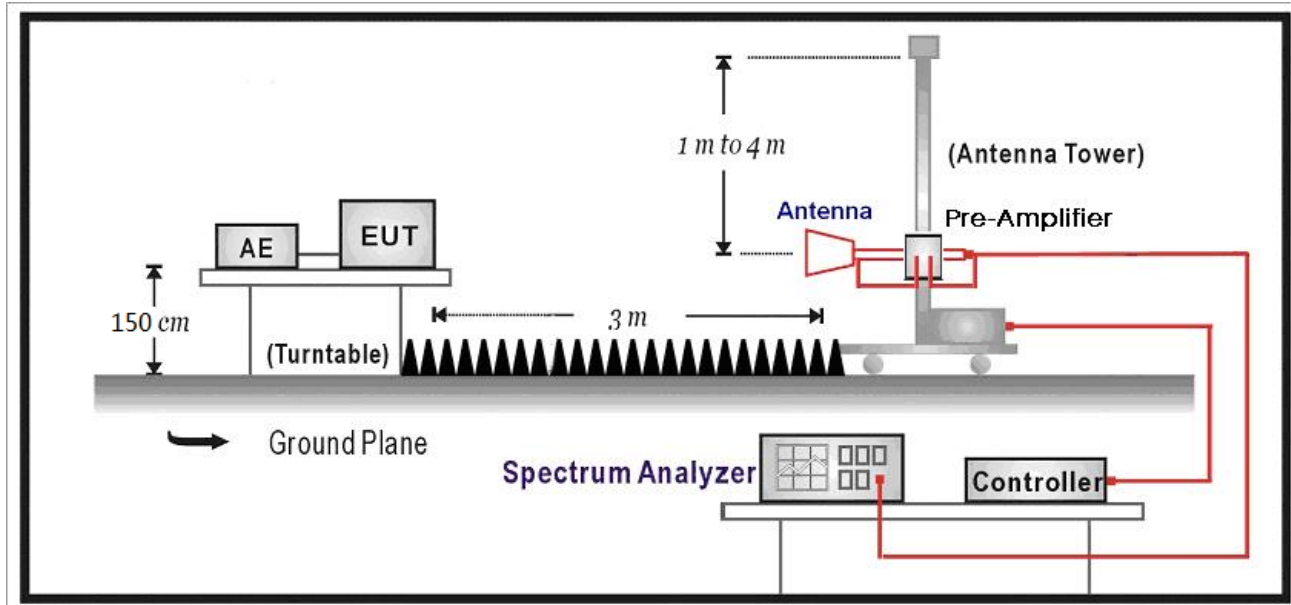

12.3. Limit

Radiated emissions which fall in the restricted bands, as defined in Section 15.205(a) of FCC part 15, must also comply with the radiated emission limits specified in Section 15.209(a) of FCC part 15.

12.4. Test Procedure

According to ANSI C63.10: 2013& ANSI C63.4: 2014

This test is required for any spurious emission or modulation product that falls in a Restricted Band, as defined in Section 15.205 of FCC part 15. It must be performed with the highest gain of each type of antenna proposed for use with the EUT. Use the following spectrum analyzer settings:

Span = wide enough to fully capture the emission being measured

RBW = 1 MHz for $f \geq 1$ GHz, 100 kHz for $f < 1$ GHz

VBW \geq RBW

Sweep = auto

Detector function = peak

Trace = max hold

Follow the guidelines in ANSI C63.4 with respect to maximizing the emission by rotating the EUT, measuring the emission while the EUT is situated in three orthogonal planes (if appropriate), adjusting the measurement antenna height and polarization, etc. A pre-amp and a high pass filter are required for this test, in order to provide the measuring system with

sufficient sensitivity. Allow the trace to stabilize. The peak reading of the emission, after being corrected by the antenna factor, cable loss, pre-amp gain, etc., is the peak field strength, which must comply with the limit specified in Section 15.35(b) of FCC part 15.

Now set the VBW to 10 Hz, while maintaining all of the other instrument settings. This peak level, once corrected, must comply with the limit specified in Section 15.209 of FCC Part 15. If the dwell time per channel of the hopping signal is less than 100 ms, then the reading obtained with the 10 Hz VBW may be further adjusted by a “duty cycle correction factor”, derived from $20\log(\text{dwell time}/100 \text{ ms})$, in an effort to demonstrate compliance with the 15.209 limit of FCC part 15.

If the emission on which a radiated measurement must be made is located at the edge of the authorized band of operation, then the alternative “marker-delta” method may be employed.

12.5. Uncertainty

The measurement uncertainty above 1G is defined as $\pm 3.9 \text{ dB}$

below 1G is defined as $\pm 3.8 \text{ dB}$

12.6. Test Result

All of the test result shown indicates the worst case, and spectrum analyzer parameters setting as shown below:

Peak detector: RBW = 1MHz, VBW = 3MHz, sweep time = 200ms;

Average = Peak Measure Level+ Duty Factor

Duty Factor= $20 \cdot \text{LOG}(\text{Pulse Number} \cdot \text{On Time}/100) = -31.37\text{dB}$ in worst condition in normal use.

Pulse Number

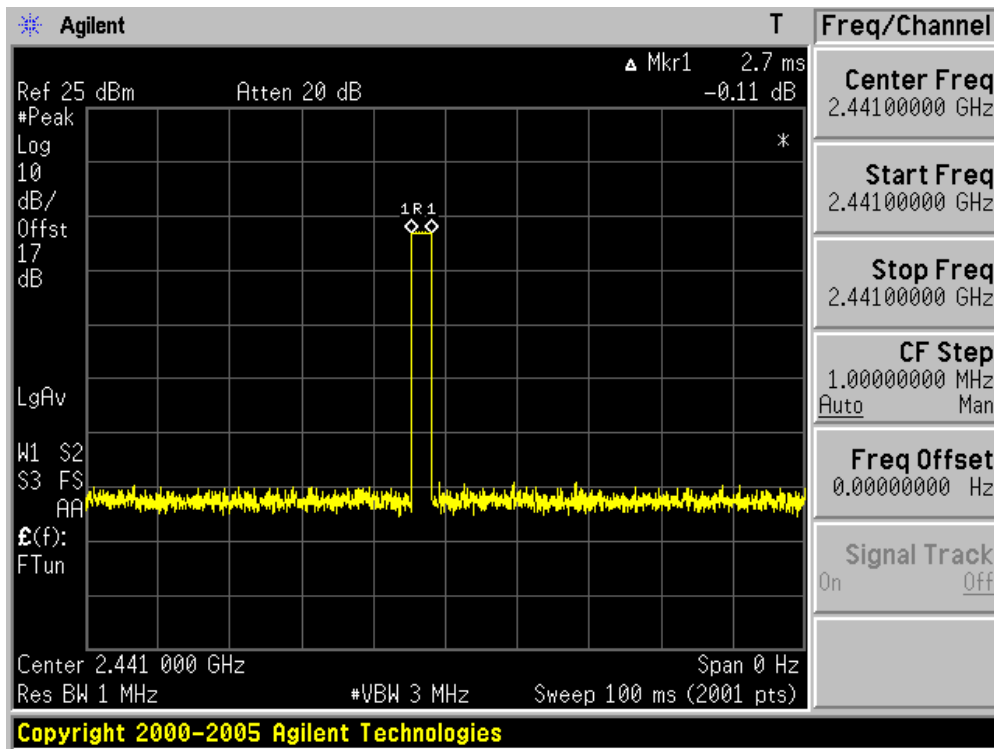

Engineer: Damon	
Site: AC5	Time: 2016/01/19 - 14:22
Limit: FCC_Part15.209_RE(3m)	Margin: 0
Probe: Horn_3117_00167055(1-18GHz)	Polarity: Horizontal
EUT: Verve Ones/Verve Ones+	Power: By PC
Note: Mode 1:Transmit at CH2402Mhz by DH5	

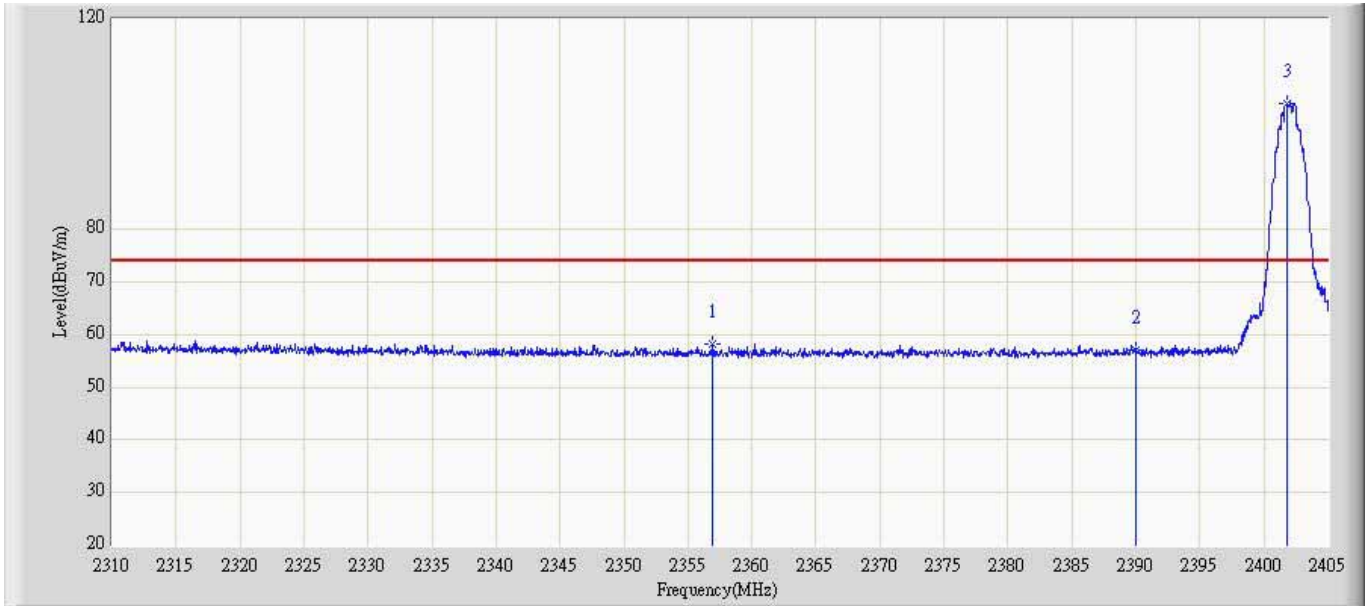

No	Mark	Frequency (MHz)	Measure Level (dBuV/m)	Reading Level (dBuV)	Over Limit (dB)	Limit (dBuV/m)	Factor (dB)	Type
1		2356.930	58.236	26.103	-15.764	74.000	32.133	PK
2		2390.000	57.125	24.891	-16.875	74.000	32.234	PK
3	*	2401.865	104.010	71.746	N/A	N/A	32.264	PK

No	Mark	Frequency (MHz)	Peak Level (dBuV/m)	AV Level (dBuV)	Over Limit (dB)	Limit (dBuV/m)	Duty Factor (dB)	Type
1		2356.930	58.236	26.866	-27.134	54.000	-31.37	AV
2		2390.000	57.125	25.755	-28.245	54.000	-31.37	AV
3	*	2401.865	104.010	72.640	N/A	N/A	-31.37	AV

Engineer: Damon	
Site: AC5	Time: 2016/01/197 - 14:26
Limit: FCC_Part15.209_RE(3m)	Margin: 0
Probe: Horn_3117_00167055(1-18GHz)	Polarity: Vertical
EUT: Verve Ones/Verve Ones+	Power: By PC
Note: Mode 1:Transmit at CH2402Mhz by DH5	

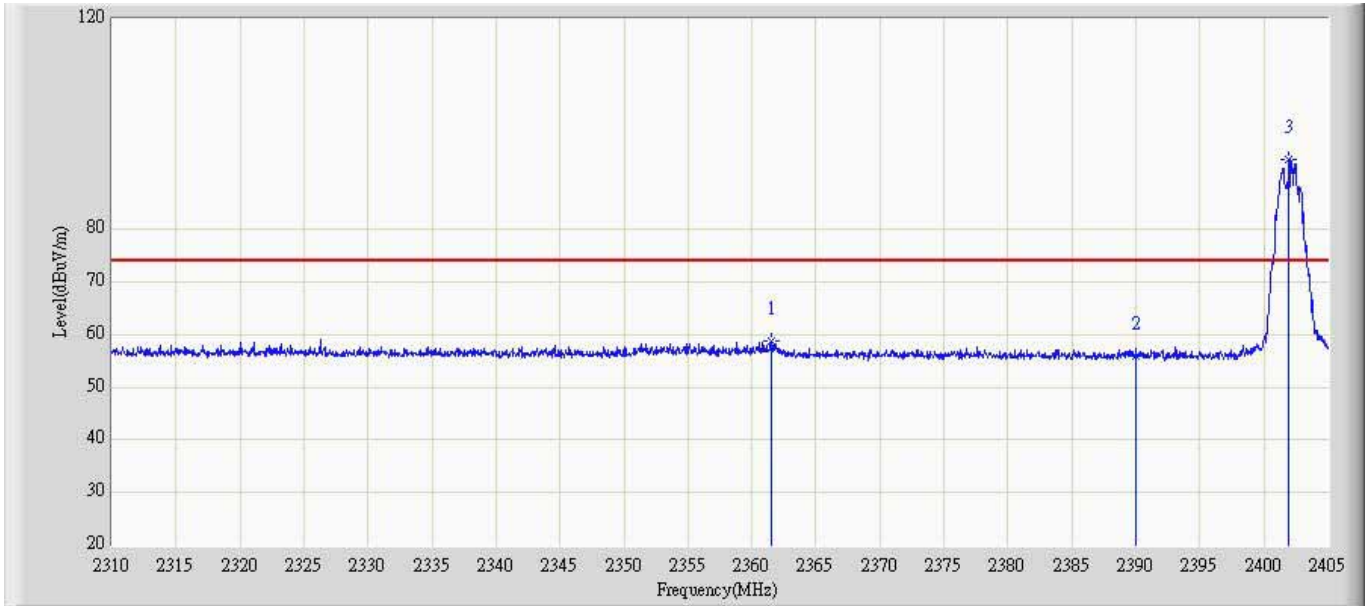

No	Mark	Frequency (MHz)	Measure Level (dBuV/m)	Reading Level (dBuV)	Over Limit (dB)	Limit (dBuV/m)	Factor (dB)	Type
1		2361.538	58.924	26.927	-15.076	74.000	31.997	PK
2		2390.000	55.836	24.228	-18.164	74.000	31.608	PK
3	*	2401.960	93.267	61.664	N/A	N/A	31.603	PK

No	Mark	Frequency (MHz)	Peak Level (dBuV/m)	AV Level (dBuV)	Over Limit (dB)	Limit (dBuV/m)	Duty Factor (dB)	Type
1		2361.538	58.924	27.554	-26.446	54.000	-31.37	AV
2		2390.000	55.836	24.466	-29.534	54.000	-31.37	AV
3	*	2401.960	93.267	61.897	N/A	N/A	-31.37	AV

Engineer: Damon	
Site: AC5	Time: 2016/01/19 - 14:32
Limit: FCC_Part15.209_RE(3m)	Margin: 0
Probe: Horn_3117_00167055(1-18GHz)	Polarity: Horizontal
EUT: Verve Ones/Verve Ones+	Power: By PC
Note: Mode 1:Transmit at CH2480Mhz by DH5	

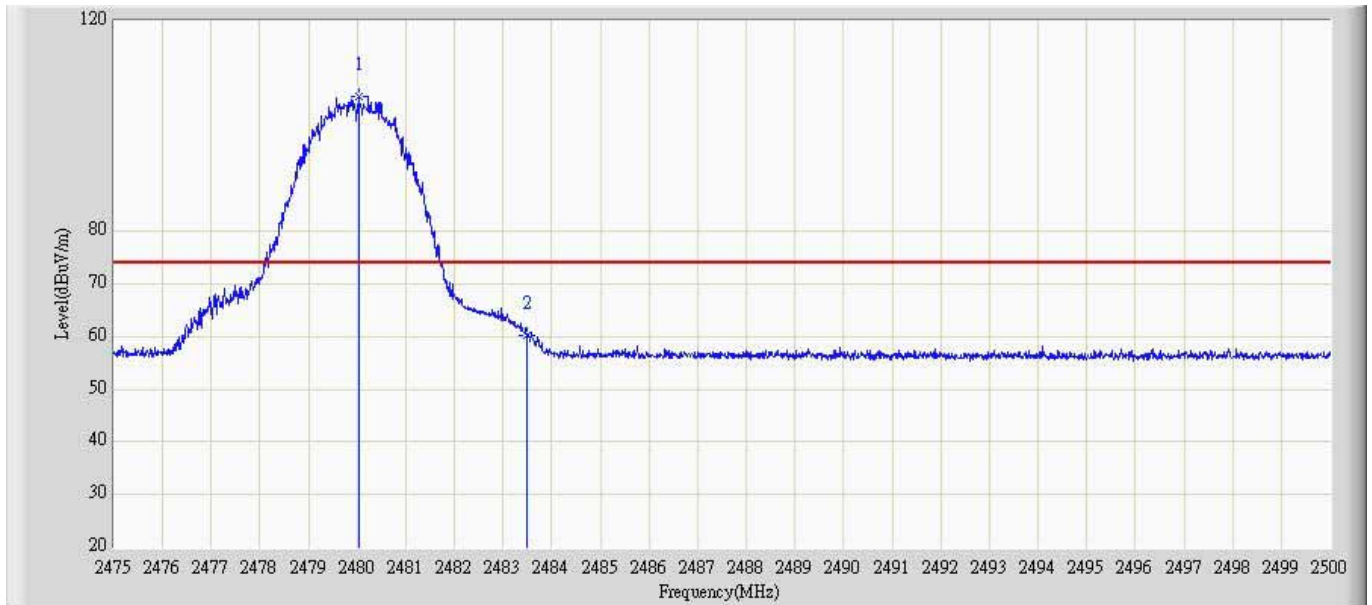

No	Mark	Frequency (MHz)	Measure Level (dBuV/m)	Reading Level (dBuV)	Over Limit (dB)	Limit (dBuV/m)	Factor (dB)	Type
1	*	2480.038	105.627	73.703	N/A	N/A	31.925	PK
2		2483.500	60.093	28.207	-13.907	74.000	31.886	PK

No	Mark	Frequency (MHz)	Peak Level (dBuV/m)	AV Level (dBuV)	Over Limit (dB)	Limit (dBuV/m)	Duty Factor (dB)	Type
1	*	2480.038	105.627	74.257	N/A	N/A	-31.37	AV
2		2483.500	60.093	28.723	-25.277	54.000	-31.37	AV

Engineer: Damon	
Site: AC5	Time: 2016/01/19 - 14:36
Limit: FCC_Part15.209_RE(3m)	Margin: 0
Probe: Horn_3117_00167055(1-18GHz)	Polarity: Vertical
EUT: Verve Ones/Verve Ones+	Power: By PC
Note: Mode 1:Transmit at CH2480Mhz by DH5	

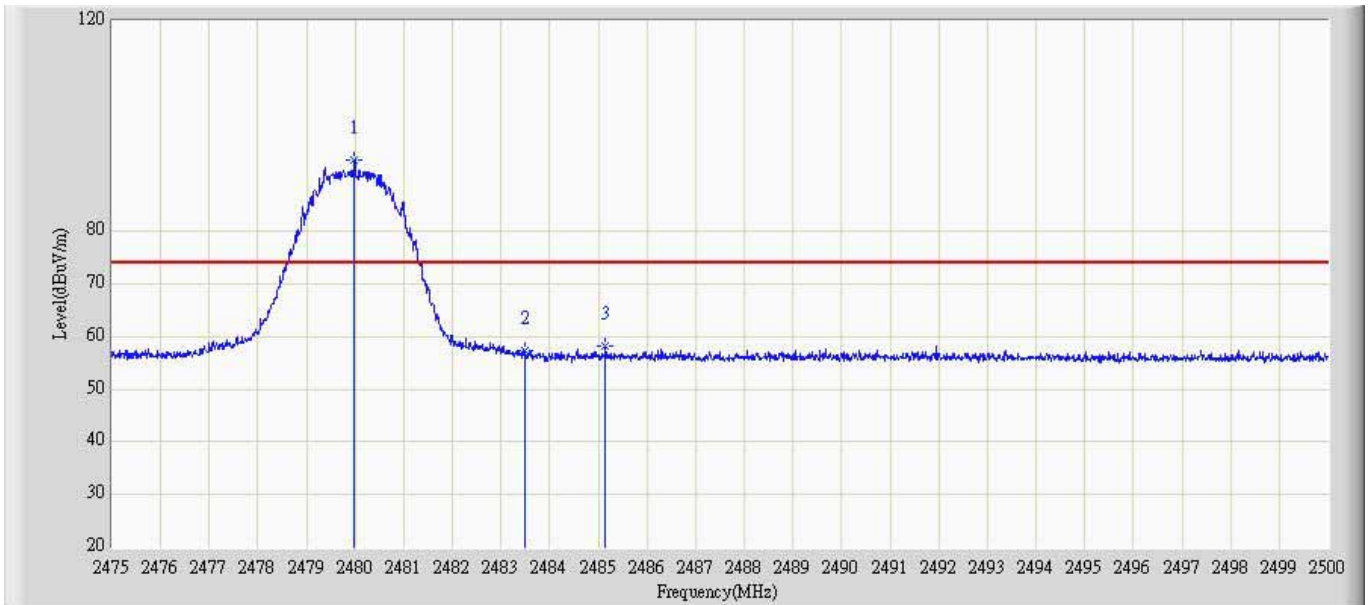

No	Mark	Frequency (MHz)	Measure Level (dBuV/m)	Reading Level (dBuV)	Over Limit (dB)	Limit (dBuV/m)	Factor (dB)	Type
1	*	2479.975	93.630	61.942	N/A	N/A	31.688	PK
2		2483.500	57.392	25.777	-16.608	74.000	31.615	PK
3		2485.150	58.146	26.566	-15.854	74.000	31.580	PK

No	Mark	Frequency (MHz)	Peak Level (dBuV/m)	AV Level (dBuV)	Over Limit (dB)	Limit (dBuV/m)	Duty Factor (dB)	Type
1	*	2479.975	93.630	62.260	N/A	N/A	-31.37	AV
2		2483.500	57.392	26.022	-27.978	54.000	-31.37	AV
3		2485.150	58.146	26.776	-27.224	54.000	-31.37	AV

Engineer: Damon	
Site: AC5	Time: 2016/01/19 - 14:40
Limit: FCC_Part15.209_RE(3m)	Margin: 0
Probe: Horn_3117_00167055(1-18GHz)	Polarity: Horizontal
EUT: Verve Ones/Verve Ones+	Power: By PC
Note: Mode 2:Transmit at CH2402Mhz by 2DH5	

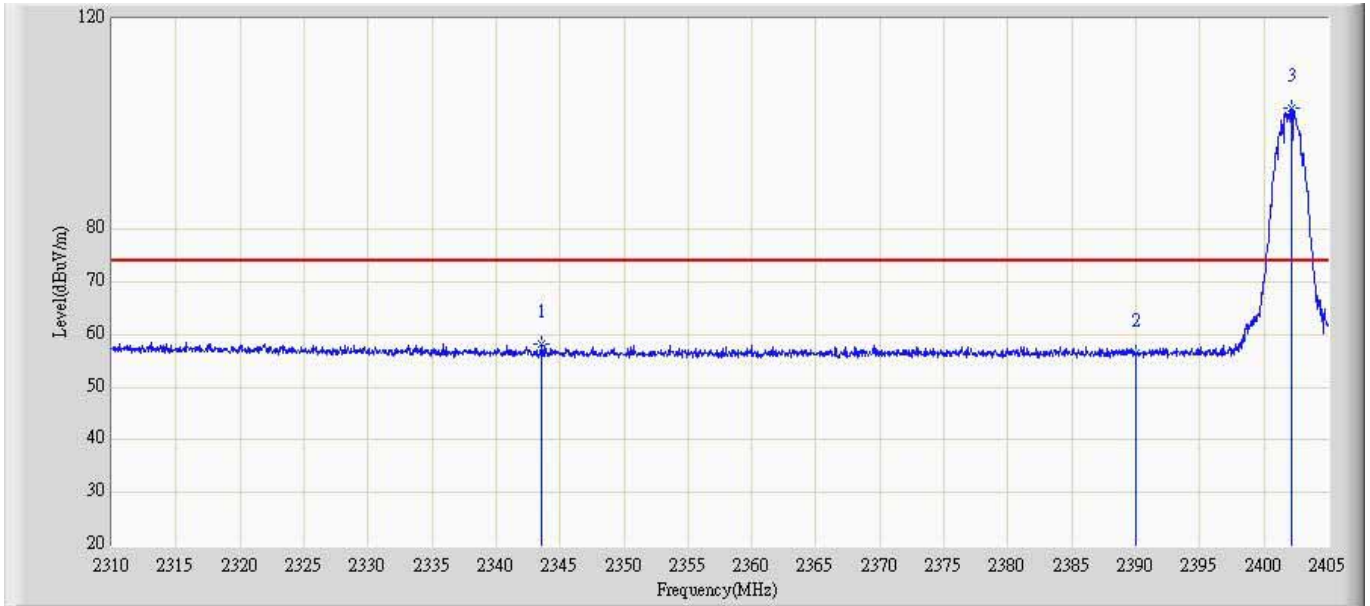

No	Mark	Frequency (MHz)	Measure Level (dBuV/m)	Reading Level (dBuV)	Over Limit (dB)	Limit (dBuV/m)	Factor (dB)	Type
1		2343.535	58.180	25.944	-15.820	74.000	32.236	PK
2		2390.000	56.416	24.182	-17.584	74.000	32.234	PK
3	*	2402.150	103.135	70.871	N/A	N/A	32.264	PK

No	Mark	Frequency (MHz)	Peak Level (dBuV/m)	AV Level (dBuV)	Over Limit (dB)	Limit (dBuV/m)	Duty Factor (dB)	Type
1		2343.535	58.180	26.810	-27.190	54.000	-31.37	AV
2		2390.000	56.416	25.046	-28.954	54.000	-31.37	AV
3	*	2402.150	103.135	71.765	N/A	N/A	-31.37	AV

Engineer: Damon	
Site: AC5	Time: 2016/01/19 - 14:43
Limit: FCC_Part15.209_RE(3m)	Margin: 0
Probe: Horn_3117_00167055(1-18GHz)	Polarity: Vertical
EUT: Verve Ones/Verve Ones+	Power: By PC
Note: Mode 2:Transmit at CH2402Mhz by 2DH5	

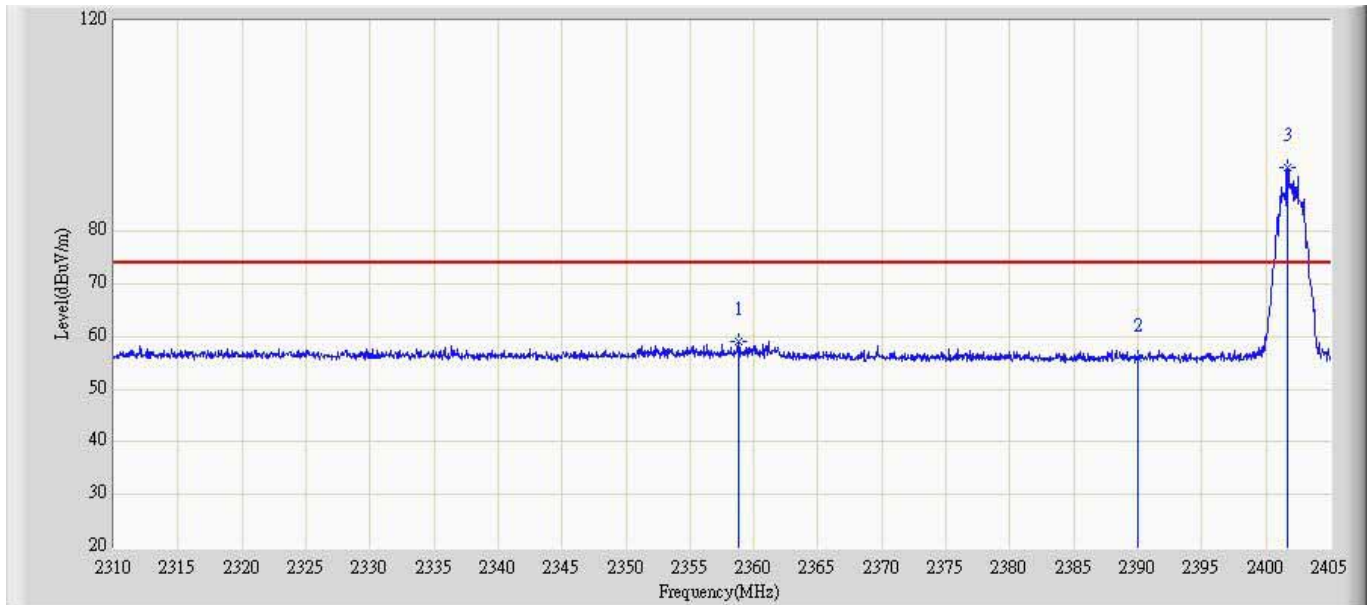

No	Mark	Frequency (MHz)	Measure Level (dBuV/m)	Reading Level (dBuV)	Over Limit (dB)	Limit (dBuV/m)	Factor (dB)	Type
1		2358.782	58.956	26.927	-15.044	74.000	32.029	PK
2		2390.000	55.953	24.345	-18.047	74.000	31.608	PK
3	*	2401.722	92.092	60.491	N/A	N/A	31.601	PK

No	Mark	Frequency (MHz)	Peak Level (dBuV/m)	AV Level (dBuV)	Over Limit (dB)	Limit (dBuV/m)	Duty Factor (dB)	Type
1		2358.782	58.956	27.586	-26.414	54.000	-31.37	AV
2		2390.000	55.953	24.583	-29.417	54.000	-31.37	AV
3	*	2401.722	92.092	60.722	N/A	N/A	-31.37	AV

Engineer: Damon	
Site: AC5	Time: 2016/01/19 - 14:48
Limit: FCC_Part15.209_RE(3m)	Margin: 0
Probe: Horn_3117_00167055(1-18GHz)	Polarity: Horizontal
EUT: Verve Ones/Verve Ones+	Power: By PC
Note: Mode 2:Transmit at CH2480Mhz by 2DH5	

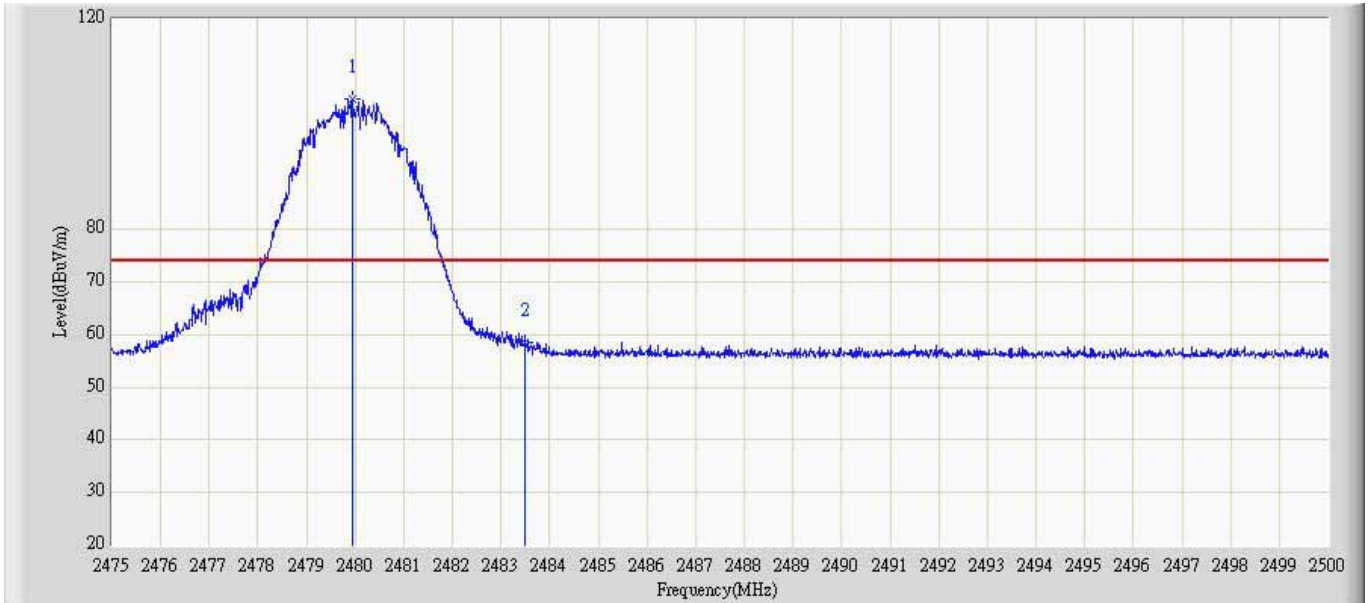

No	Mark	Frequency (MHz)	Measure Level (dBuV/m)	Reading Level (dBuV)	Over Limit (dB)	Limit (dBuV/m)	Factor (dB)	Type
1	*	2479.937	104.868	72.942	N/A	N/A	31.926	PK
2		2483.500	58.552	26.666	-15.448	74.000	31.886	PK

No	Mark	Frequency (MHz)	Peak Level (dBuV/m)	AV Level (dBuV)	Over Limit (dB)	Limit (dBuV/m)	Duty Factor (dB)	Type
1	*	2479.937	104.868	73.498	N/A	N/A	-31.37	AV
2		2483.500	58.552	27.182	-26.818	54.000	-31.37	AV

Engineer: Damon	
Site: AC5	Time: 2016/01/19 - 14:51
Limit: FCC_Part15.209_RE(3m)	Margin: 0
Probe: Horn_3117_00167055(1-18GHz)	Polarity: Vertical
EUT: Verve Ones/Verve Ones+	Power: By PC
Note: Mode 2:Transmit at CH2480Mhz by 2DH5	

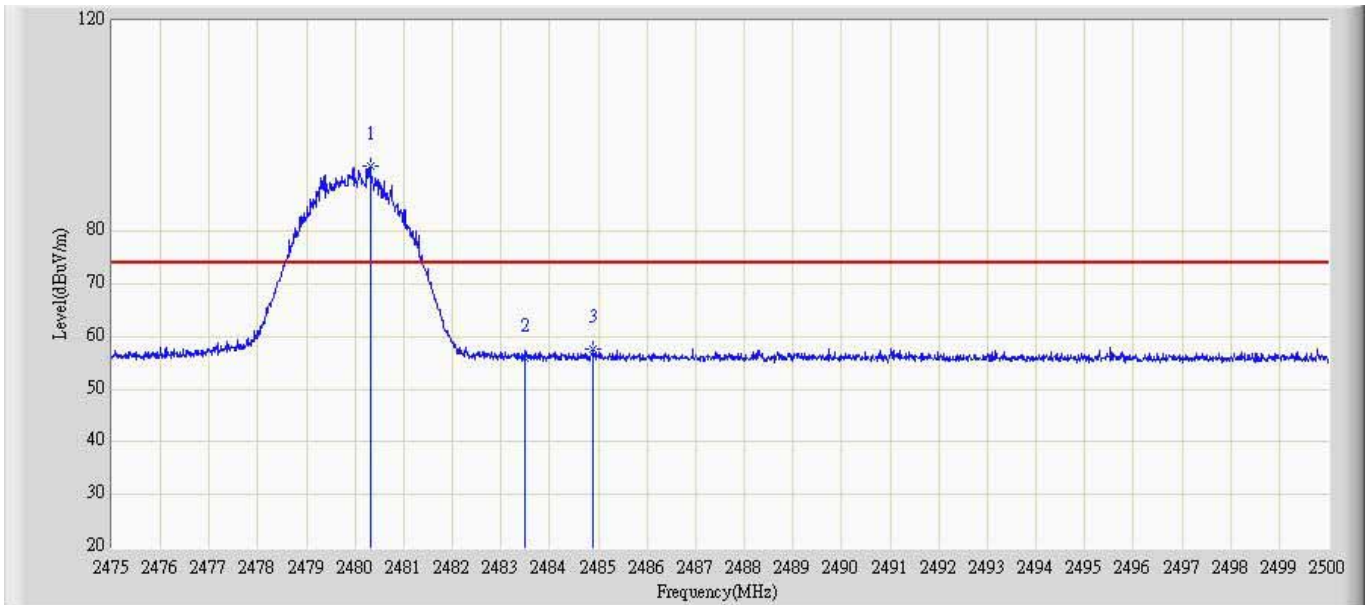

No	Mark	Frequency (MHz)	Measure Level (dBuV/m)	Reading Level (dBuV)	Over Limit (dB)	Limit (dBuV/m)	Factor (dB)	Type
1	*	2480.312	92.490	60.809	N/A	N/A	31.681	PK
2		2483.500	55.858	24.243	-18.142	74.000	31.615	PK
3		2484.900	57.636	26.051	-16.364	74.000	31.585	PK

No	Mark	Frequency (MHz)	Peak Level (dBuV/m)	AV Level (dBuV)	Over Limit (dB)	Limit (dBuV/m)	Duty Factor (dB)	Type
1	*	2480.312	92.490	61.120	N/A	N/A	-31.37	AV
2		2483.500	55.858	24.488	-29.512	54.000	-31.37	AV
3		2484.900	57.636	26.266	-27.734	54.000	-31.37	AV

Engineer: Damon	
Site: AC5	Time: 2016/01/19- 14:54
Limit: FCC_Part15.209_RE(3m)	Margin: 0
Probe: Horn_3117_00167055(1-18GHz)	Polarity: Horizontal
EUT: Verve Ones/Verve Ones+	Power: By PC
Note: Mode 3:Transmit at CH2402Mhz by 3DH5	

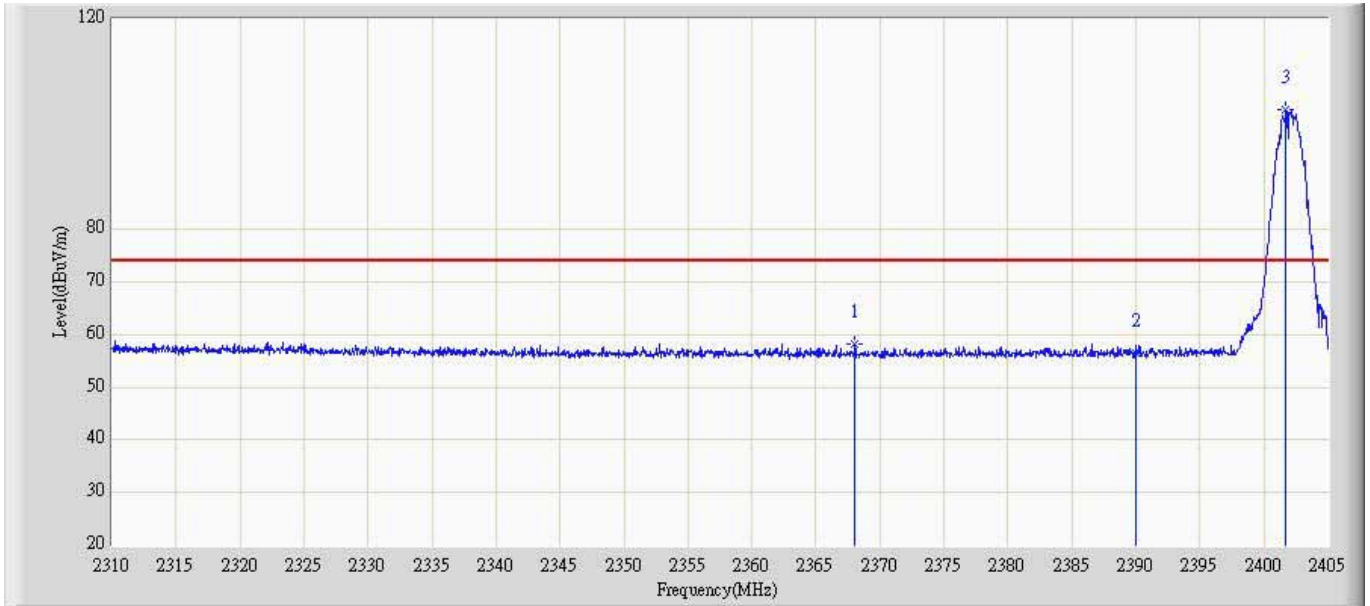

No	Mark	Frequency (MHz)	Measure Level (dBuV/m)	Reading Level (dBuV)	Over Limit (dB)	Limit (dBuV/m)	Factor (dB)	Type
1		2368.045	58.178	26.035	-15.822	74.000	32.143	PK
2		2390.000	56.376	24.142	-17.624	74.000	32.234	PK
3	*	2401.722	102.637	70.373	N/A	N/A	32.264	PK

No	Mark	Frequency (MHz)	Peak Level (dBuV/m)	AV Level (dBuV)	Over Limit (dB)	Limit (dBuV/m)	Duty Factor (dB)	Type
1		2368.045	58.178	26.808	-27.192	54.000	-31.37	AV
2		2390.000	56.376	25.006	-28.994	54.000	-31.37	AV
3	*	2401.722	102.637	71.267	N/A	N/A	-31.37	AV

Engineer: Damon	
Site: AC5	Time: 2016/01/19 - 14:58
Limit: FCC_Part15.209_RE(3m)	Margin: 0
Probe: Horn_3117_00167055(1-18GHz)	Polarity: Vertical
EUT: Verve Ones/Verve Ones+	Power: By PC
Note: Mode 3:Transmit at CH2402Mhz by 3DH5	

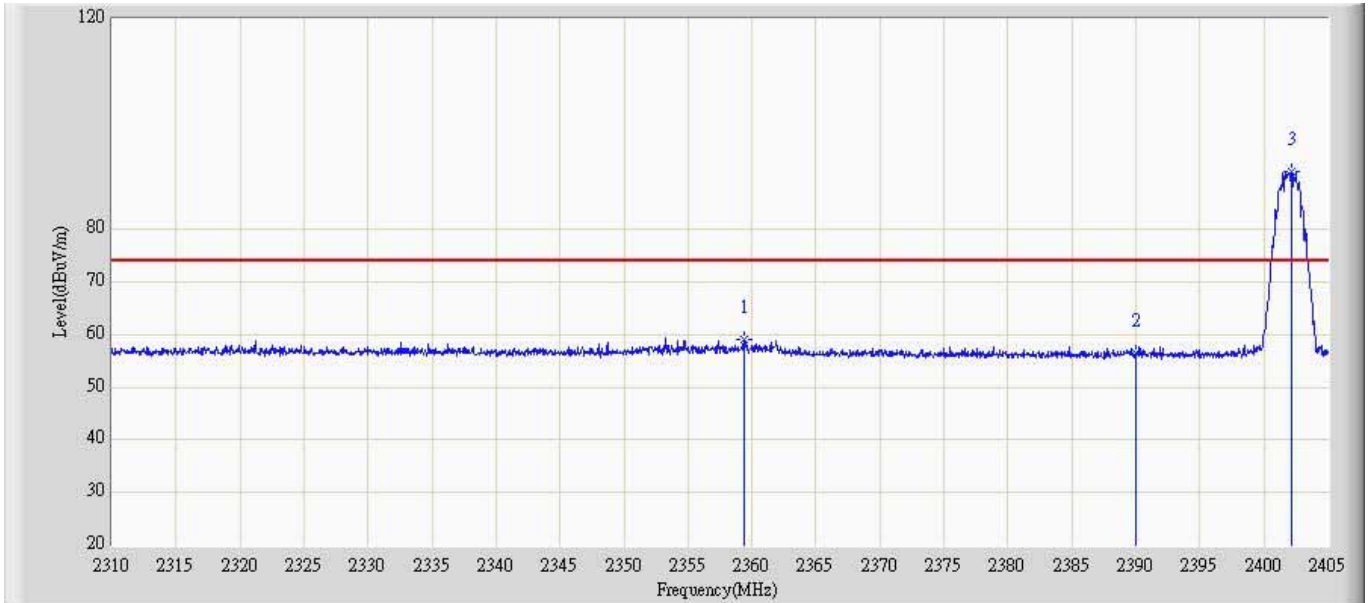

No	Mark	Frequency (MHz)	Measure Level (dBuV/m)	Reading Level (dBuV)	Over Limit (dB)	Limit (dBuV/m)	Factor (dB)	Type
1		2359.353	59.032	27.008	-14.968	74.000	32.024	PK
2		2390.000	56.356	24.748	-17.644	74.000	31.608	PK
3	*	2402.150	90.971	59.367	N/A	N/A	31.604	PK

No	Mark	Frequency (MHz)	Peak Level (dBuV/m)	AV Level (dBuV)	Over Limit (dB)	Limit (dBuV/m)	Duty Factor (dB)	Type
1		2359.353	59.032	27.662	-26.338	54.000	-31.37	AV
2		2390.000	56.356	24.986	-29.014	54.000	-31.37	AV
3	*	2402.150	90.971	59.601	N/A	N/A	-31.37	AV

Engineer: Damon	
Site: AC5	Time: 2016/01/19 - 15:03
Limit: FCC_Part15.209_RE(3m)	Margin: 0
Probe: Horn_3117_00167055(1-18GHz)	Polarity: Horizontal
EUT: Verve Ones/Verve Ones+	Power: By PC
Note: Mode 3:Transmit at CH2480Mhz by 3DH5	

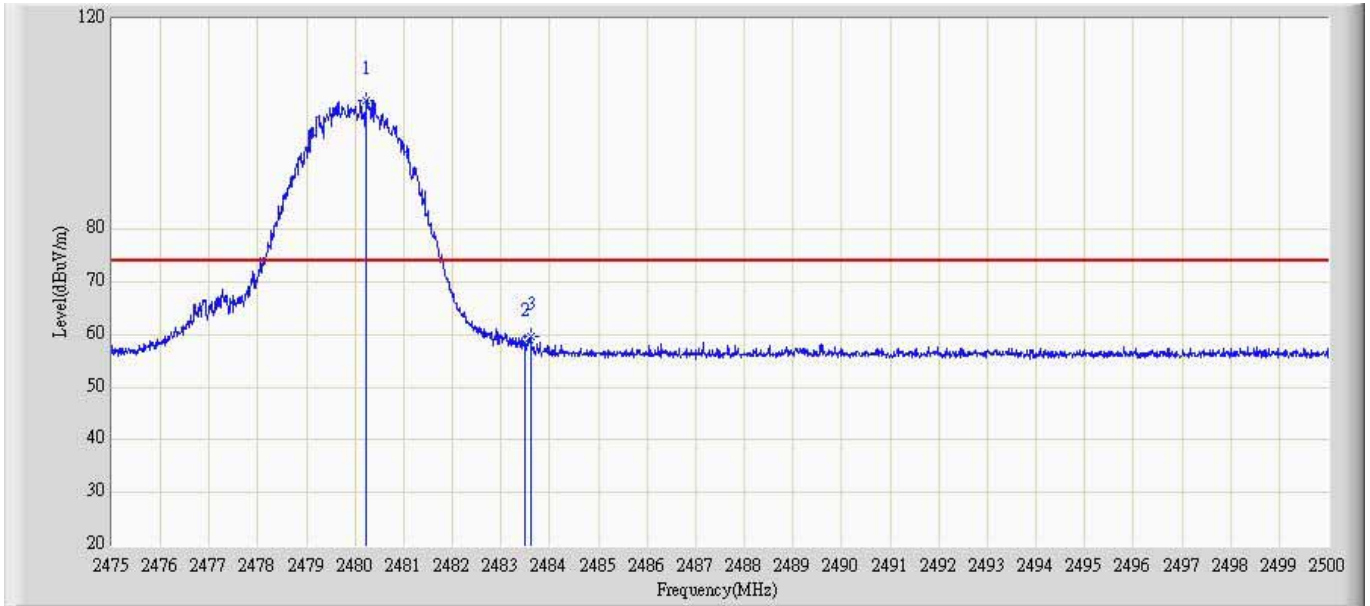

No	Mark	Frequency (MHz)	Measure Level (dBuV/m)	Reading Level (dBuV)	Over Limit (dB)	Limit (dBuV/m)	Factor (dB)	Type
1	*	2480.238	104.492	72.570	N/A	N/A	31.923	PK
2		2483.500	58.570	26.684	-15.430	74.000	31.886	PK
3		2483.600	59.585	27.700	-14.415	74.000	31.885	PK

No	Mark	Frequency (MHz)	Peak Level (dBuV/m)	AV Level (dBuV)	Over Limit (dB)	Limit (dBuV/m)	Duty Factor (dB)	Type
1	*	2480.238	104.492	73.122	N/A	N/A	-31.37	AV
2		2483.500	58.570	27.200	-26.800	54.000	-31.37	AV
3		2483.600	59.585	28.215	-25.785	54.000	-31.37	AV

Engineer: Damon	
Site: AC5	Time: 2016/01/19 - 15:06
Limit: FCC_Part15.209_RE(3m)	Margin: 0
Probe: Horn_3117_00167055(1-18GHz)	Polarity: Vertical
EUT: Verve Ones/Verve Ones+	Power: By PC
Note: Mode 3:Transmit at CH2480Mhz by 3DH5	

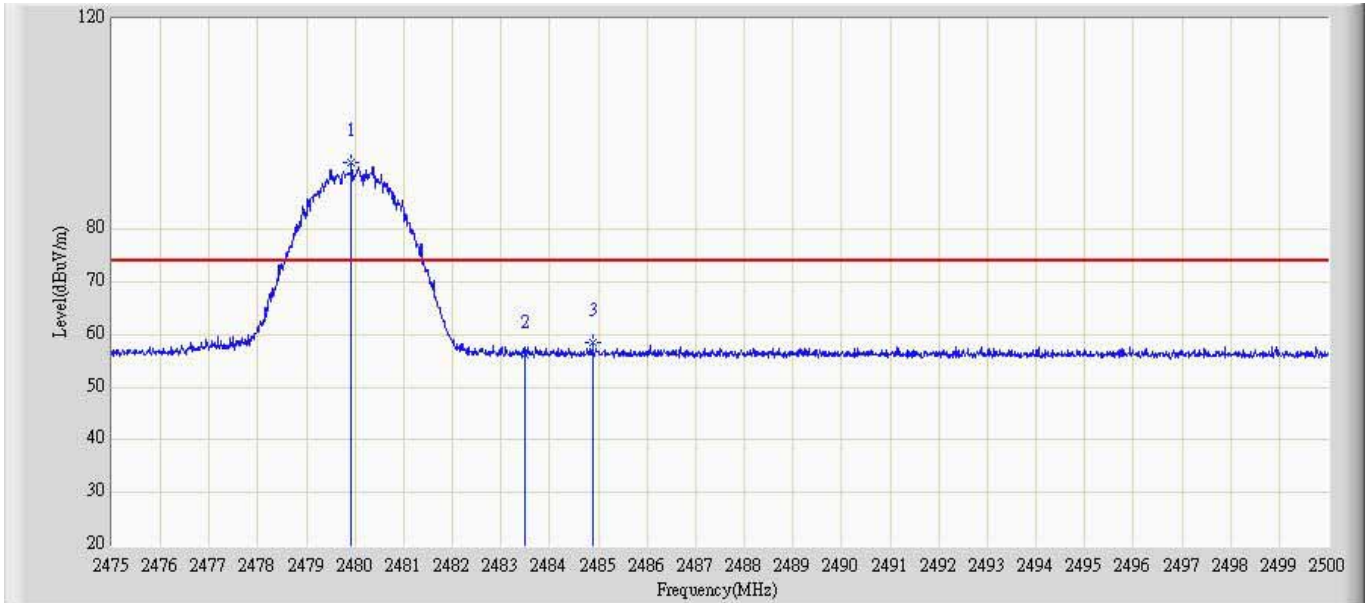

No	Mark	Frequency (MHz)	Measure Level (dBuV/m)	Reading Level (dBuV)	Over Limit (dB)	Limit (dBuV/m)	Factor (dB)	Type
1	*	2479.913	92.588	60.899	18.588	74.000	31.689	PK
2		2483.500	56.211	24.596	-17.789	74.000	31.615	PK
3		2484.887	58.436	26.850	-15.564	74.000	31.585	PK

No	Mark	Frequency (MHz)	Peak Level (dBuV/m)	AV Level (dBuV)	Over Limit (dB)	Limit (dBuV/m)	Duty Factor (dB)	Type
1	*	2479.913	92.588	61.218	N/A	N/A	-31.37	AV
2		2483.500	56.211	24.841	-29.159	54.000	-31.37	AV
3		2484.887	58.436	27.066	-26.934	54.000	-31.37	AV

————— The End —————