

TEST REPORT

Report Number: 17050111HKG-001

Application for Original Grant of 47 CFR Part 15 Certification

Single New of RSS-247 Issue 2 Equipment

FCC ID: VLJ-MBP70SN

IC: 4522A-MBP70SN

PREPARED AND CHECKED BY:

APPROVED BY:

Signed On File
Yao Xin Lu, Josie
Engineer

Koo Wai Ip
Technical Supervisor
Date: June 06, 2017

Intertek's standard Terms and Conditions can be obtained at our website <http://www.intertek.com/terms/>.

The test report only allows to be revised within the retention period unless further standard or the requirement was noticed

This report is for the exclusive use of Intertek's Client and is provided pursuant to the agreement between Intertek and its Client. Intertek's responsibility and liability are limited to the terms and conditions of the agreement. Intertek assumes no liability to any party, other than to the Client in accordance with the agreement, for any loss, expense or damage occasioned by the use of this report. Only the Client is authorized to permit copying or distribution of this report and then only in its entirety. Any use of the Intertek name or one of its marks for the sale or advertisement of the tested material, product or service must first be approved in writing by Intertek. The observations and test results in this report are relevant only to the sample tested. This report by itself does not imply that the material, product, or service is or has ever been under an Intertek certification program.

© 2017 Intertek

TEST REPORT**GENERAL INFORMATION**

Applicant Name:	Binatone Electronics International Limited
Applicant Address:	Floor 23A, 9 Des Voeux Road West, Sheung Wan, Hong Kong.
FCC Specification Standard:	FCC Part 15, October 1, 2015 Edition
FCC ID:	VLJ-MBP70SN
FCC Model(s):	MBP70SN
IC Specification Standard:	RSS-247 Issue 2, February 2017 RSS-Gen Issue 4, November 2014
IC:	4522A-MBP70SN
PMN:	Smart Touchless Forehead Thermometer
HVIN:	MBP70SN,
Type of EUT:	Spread Spectrum Transmitter Transceiver
Description of EUT:	Smart Touchless Forehead Thermometer
Serial Number:	N/A
Sample Receipt Date:	May 18, 2017
Date of Test:	June 14, 2017 to June 23, 2017
Report Date:	June 06, 2017
Environmental Conditions:	Temperature: +10 to 40°C Humidity: 10 to 90%

TEST REPORT

TABLE OF CONTENTS

1.0 Test Results Summary & Statement of Compliance 4
 1.1 Summary of Test Results 4
 1.2 Statement of Compliance 4

2.0 General Description 5
 2.1 Product Description 5
 2.2 Test Methodology 5
 2.3 Test Facility 5
 2.4 Related Submittal(s) Grants 5

3.0 System Test Configuration 6
 3.1 Justification 6
 3.2 EUT Exercising Software 6
 3.3 Details of EUT and Description of Accessories 7
 3.4 Measurement Uncertainty 7

4.0 Test Results 8
 4.1 Maximum Conducted Output Power at Antenna Terminals 8
 4.2 Minimum 6dB RF Bandwidth 9
 4.3 Maximum Power Spectral Density 12
 4.4 Out of Band Conducted Emissions 15
 4.5 Field Strength Calculation 19
 4.6 Transmitter Radiated Emissions in Restricted Bands and Spurious Emissions 20
 4.6.1 Radiated Emission Configuration Photograph 20
 4.6.2 Radiated Emission Data 20
 4.6.3 Radiated Emission Test Setup 25
 4.6.4 Transmitter Duty Cycle Calculation 26

5.0 Equipment List 27

TEST REPORT

EXHIBIT 1 TEST RESULTS SUMMARY & STATEMENT OF COMPLIANCE

1.0 TEST RESULTS SUMMARY & STATEMENT OF COMPLIANCE

1.1 Summary of Test Results

TEST ITEMS	FCC PART 15 SECTION	RSS-247/ RSS-GEN# SECTION	RESULTS	DETAILS SEE SECTION
Antenna Requirement	15.203	8.3#	Pass	2.1
Max. Conducted Output Power (Peak)	15.247(b)(3)&(4)	5.4(4)	Pass	4.1
Min. 6dB RF Bandwidth	15.247(a)(2)	5.2(1)	Pass	4.2
Max. Power Density (average)	15.247(e)	5.2(2)	Pass	4.3
Out of Band Antenna Conducted Emission	15.247(d)	5.5	Pass	4.4
Radiated Emission in Restricted Bands and Spurious Emissions	15.247(d), 15.209 & 15.109	5.5	Pass	4.6

Note: Pursuant to FCC Part 15 Section 15.215(c), the 20dB bandwidth of the emission was contained within the frequency band designated (mentioned as above) which the EUT operated. The effects, if any, from frequency sweeping, frequency hopping, other modulation techniques and frequency stability over expected variations in temperature and supply voltage were considered.

1.2 Statement of Compliance

The equipment under test is found to be complying with the following standard:

FCC Part 15, October 1, 2015 Edition
RSS-247 Issue 2, February 2017
RSS-Gen Issue 4, November 2014

TEST REPORT**EXHIBIT 2 GENERAL DESCRIPTION****2.0 GENERAL DESCRIPTION****2.1 Product Description**

The MBP70SN is a Smart Touchless Forehead Thermometer.

The Equipment Under Test (EUT) is a Bluetooth Smart Touchless Forehead Thermometer. The EUT can only support Bluetooth 4.1 BLE that occupies a frequency range of 2402MHz to 2480MHz (40 channels with channel spacing of 2MHz). The EUT is powered by 3VDC (2 X size "AAA" batteries).

The antenna(s) used in the EUT is integral, and the test sample is a prototype.

The circuit description is saved with filename: descri.pdf.

2.2 Test Methodology

Radiated emission measurements were performed according to the procedures in ANSI C63.10 (2013). Preliminary radiated scans and all radiated measurements were performed in radiated emission test sites. All Radiated tests were performed at an antenna to EUT distance of 3 meters, unless stated otherwise in the "**Justification Section**" of this Application. Antenna port conducted measurements were performed according to ANSI C63.10 (2013) and KDB Publication No.558074 D01 v04 (05-April-2017) All other measurements were made in accordance with the procedures in 47 CFR Part 2 and RSS-Gen Issue 4 (2014).

2.3 Test Facility

The radiated emission test site and antenna port conducted measurement facility used to collect the radiated data is located at Workshop No.10-1 Mingkeda Logistics Park, No.18 Huanguan South RD. Guan lan Town, Baoan Distr, Shenzhen, Guangdong, China. This test facility and site measurement data have been fully placed on file with the FCC and Industry Canada. The FCC Registration Number is 441872, IC Registration Number is 2324I-2.

2.4 Related Submittal(s) Grants

This is a single application for certification of a transceiver (Bluetooth 4.1 BLE portion)

TEST REPORT

EXHIBIT 3 SYSTEM TEST CONFIGURATION

3.0 SYSTEM TEST CONFIGURATION

3.1 Justification

For radiated emissions testing, the equipment under test (EUT) was setup to transmit / receive continuously to simplify the measurement methodology. Care was taken to ensure proper power supply voltages during testing. During testing, all cables (if any) were manipulated to produce worst case emissions.

The EUT was powered by 3.0VDC (2 X size "AAA" batteries).

For the measurements, the EUT was attached to a plastic stand if necessary and placed on the wooden turntable. If the base unit attached to peripherals, they were connected and operational (as typical as possible).

The signal was maximized through rotation and placement in the three orthogonal axes. The antenna height and polarization were varied during the search for maximum signal level. The antenna height was varied from 1 to 4 meters. Radiated emissions were taken at three meters unless the signal level was too low for measurement at that distance. If necessary, a pre-amplifier was used and/or the test was conducted at a closer distance.

Radiated emission measurement for transmitter were performed from the lowest radio frequency signal generated in the device which is greater than 9 kHz to the tenth harmonic of the highest fundamental frequency or to 40 GHz, whichever is lower.

Emission that are directly caused by digital circuits in the transmit path and transmitter portion were measured, and the limit are according to FCC Part 15 Section 15.209. Digital circuitries used to control additional functions other than the operation of the transmitter are subject to FCC Part 15 Section 15.109.

3.1 EUT Exercising Software

The EUT exercise program (if any) used during radiated and conducted testing was designed to exercise the various system components in a manner similar to a typical use.

TEST REPORT**3.2 Details of EUT and Description of Accessories***Details of EUT:*

The EUT was powered by 3.0VDC (2 X size “AAA” batteries).

Description of Accessories:

There are no accessories for compliance of this product.

3.3 Measurement Uncertainty

When determining of the test conclusion, the Measurement Uncertainty of test at a level of confidence of 95% has been considered. The values of the Measurement uncertainty for radiated emission test and RF conducted measurement test are $\pm 5.3\text{dB}$ and $\pm 0.99\text{dB}$ respectively. The value of the Measurement uncertainty for conducted emission test is $\pm 3.3\text{dB}$.

Uncertainty and Compliance - Unless the standard specifically states that measured values are to be extended by the measurement uncertainty in determining compliance, all compliance determinations are based on the actual measured value.

TEST REPORT

EXHIBIT 4 TEST RESULTS

4.0 TEST RESULTS

4.1 Maximum Conducted (peak) Output Power at Antenna Terminals

RF Conduct Measurement Test Setup

The figure below shows the test setup, which is utilized to make these measurements.

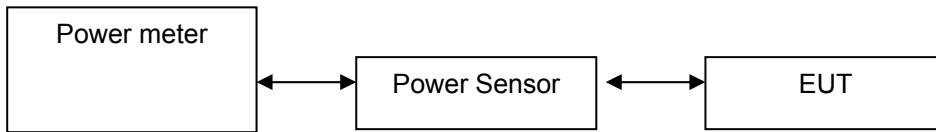

- The antenna power of the EUT was connected to the input of a power meter. Power was read directly and cable loss correction was added to the reading to the obtain power at the EUT antenna terminals. The measurement procedure 9.1.3 of KDB558074 D01 v04 (05-April-2017) was used.
- The EUT should be configured to transmit continuously (at a minimum duty cycle of 98%) at full power over the measurement duration. The measurement procedure AVG1 was used.

GFSK Antenna Gain = 0 dBi

Frequency (MHz)		Output in dBm	Output in mWatt
Low Channel:	2402	-1.12	0.77
Middle Channel:	2440	-1.37	0.73
High Channel:	2480	-1.51	0.71

TEST REPORT

4.2 Minimum 6dB RF Bandwidth

The antenna port of the EUT was connected to the input of a spectrum analyzer. The EBW measurement procedure of KDB558074 D01 v04 (05-April-2017) was used. A PEAK output reading was taken, a DISPLAY line was drawn 6dB lower than PEAK level. The 6dB bandwidth was determined from where the channel output spectrum intersected the display line.

GFSK

Frequency (MHz)		6dB Bandwidth (MHz)
Low Channel:	2402	0.6704
Middle Channel:	2440	0.6689
High Channel:	2480	0.6719

Limits

6 dB bandwidth shall be at least 500kHz

The plots of 6dB RF bandwidth are saved as below.

TEST REPORT

PLOTS OF 6dB RF BANDWIDTH

Lowest Channel

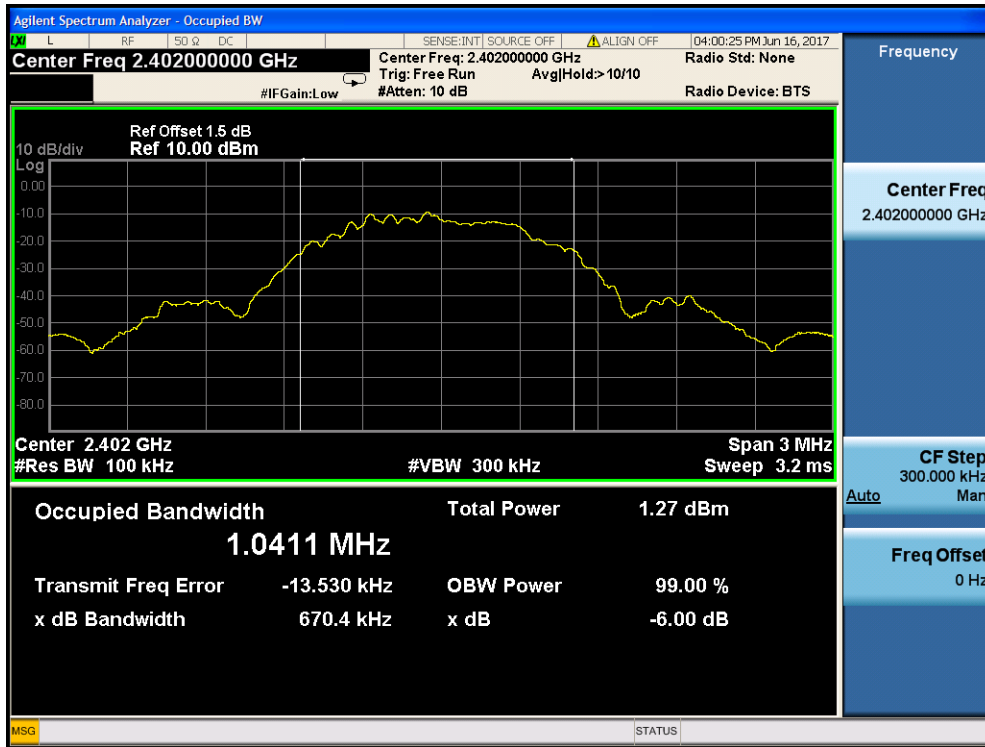

Middle Channel



TEST REPORT

PLOTS OF 6dB RF BANDWIDTH

Highest Channel

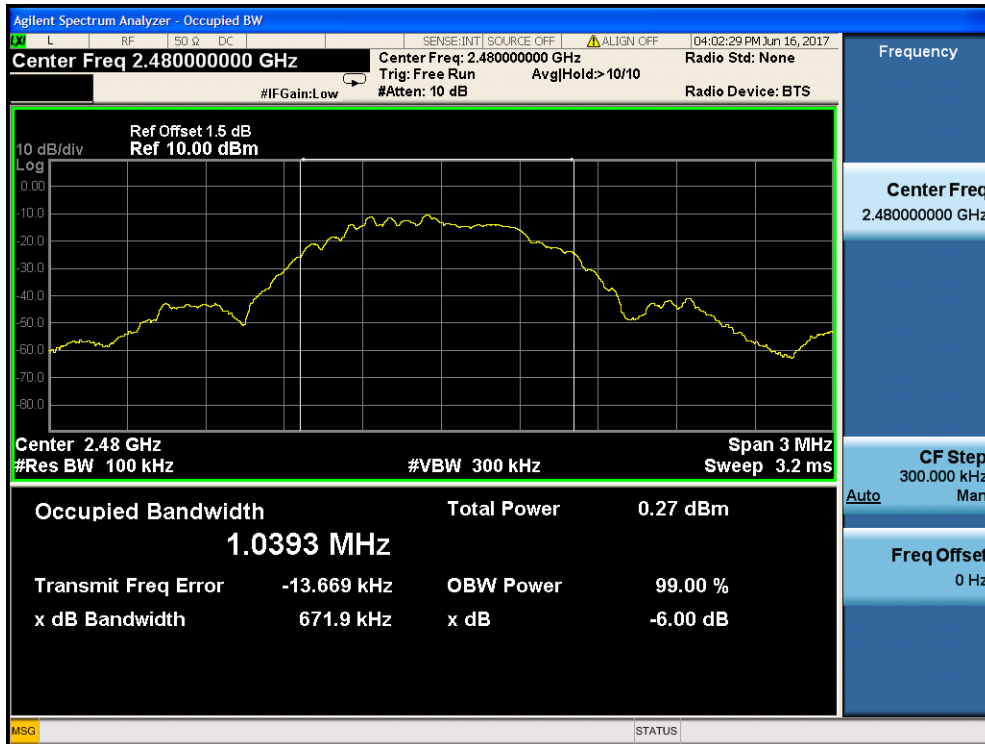

TEST REPORT**4.3 Maximum Power Spectral Density**

Antenna output of the EUT was coupled directly to spectrum analyzer. The measurement procedure 10.2 PKPSD-1 of KDB558074 D01 v04 (05-April-2017) was used. If an external attenuator and/or cable was used, these losses are compensated for using the OFFSET function of the analyser.

IEEE 802.11b (DSSS, 1 Mbps)

Frequency (MHz)	PSD in 3kHz (dBm)
Low Channel: 2402	-20.542
Middle Channel: 2440	-20.791
High Channel: 2480	-21.044

Cable Loss: 1.5 dB

Limit:
8dBm

The plots of power spectral density are as below.

TEST REPORT

PLOTS OF POWER SPECTRAL DENSITY

Lowest channel

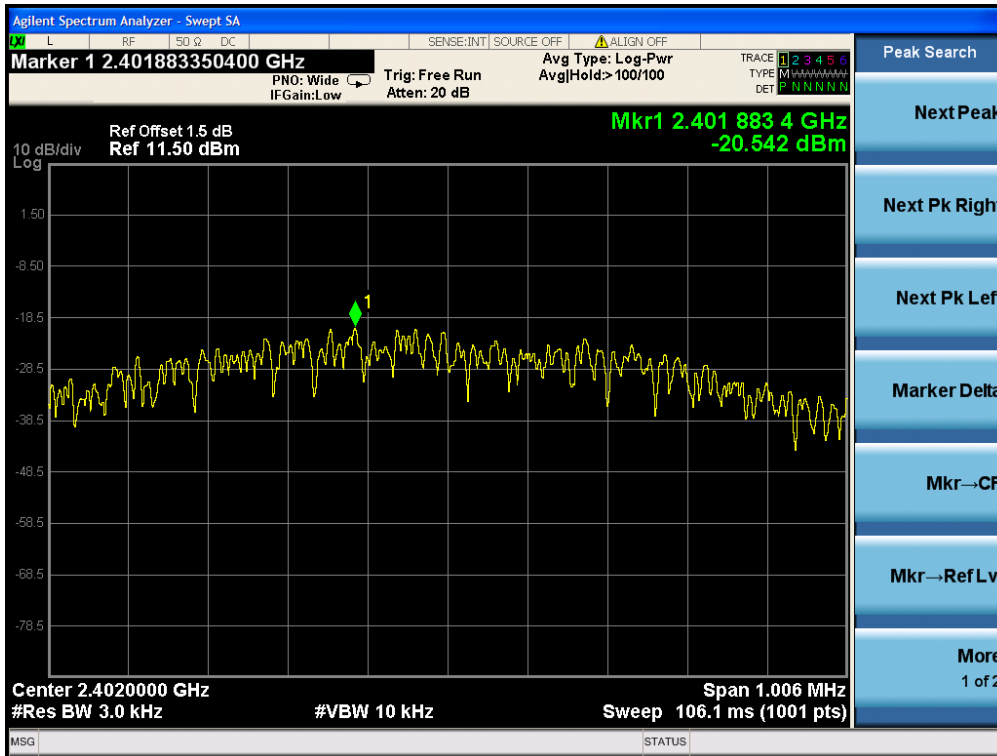

Middle channel

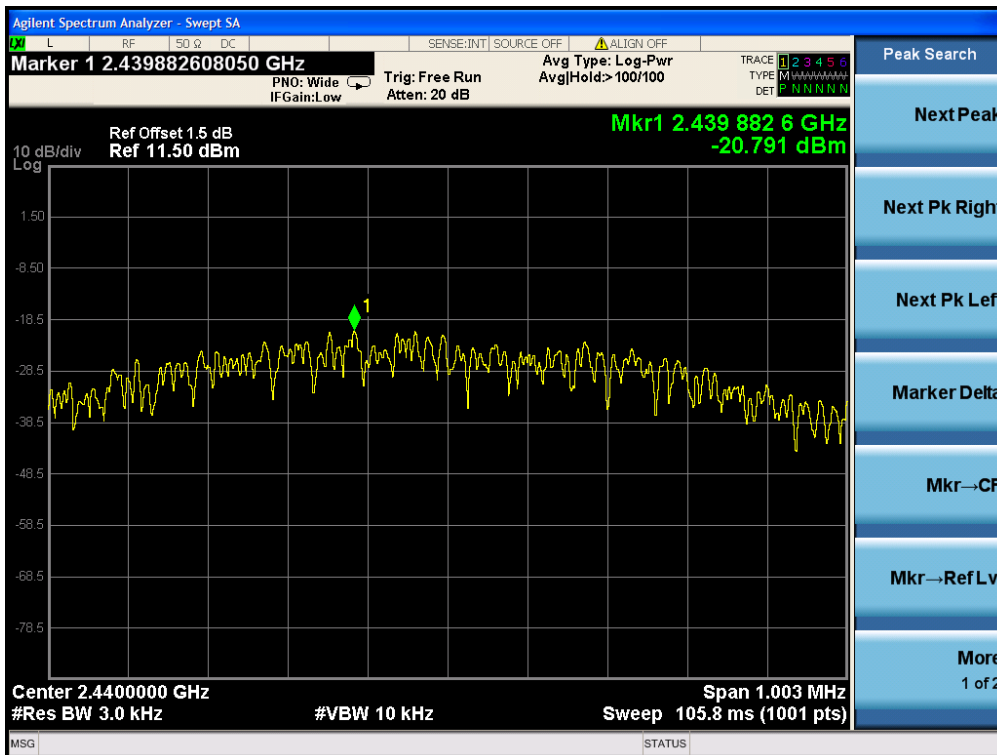

TEST REPORT

PLOTS OF POWER SPECTRAL DENSITY

Highest channel

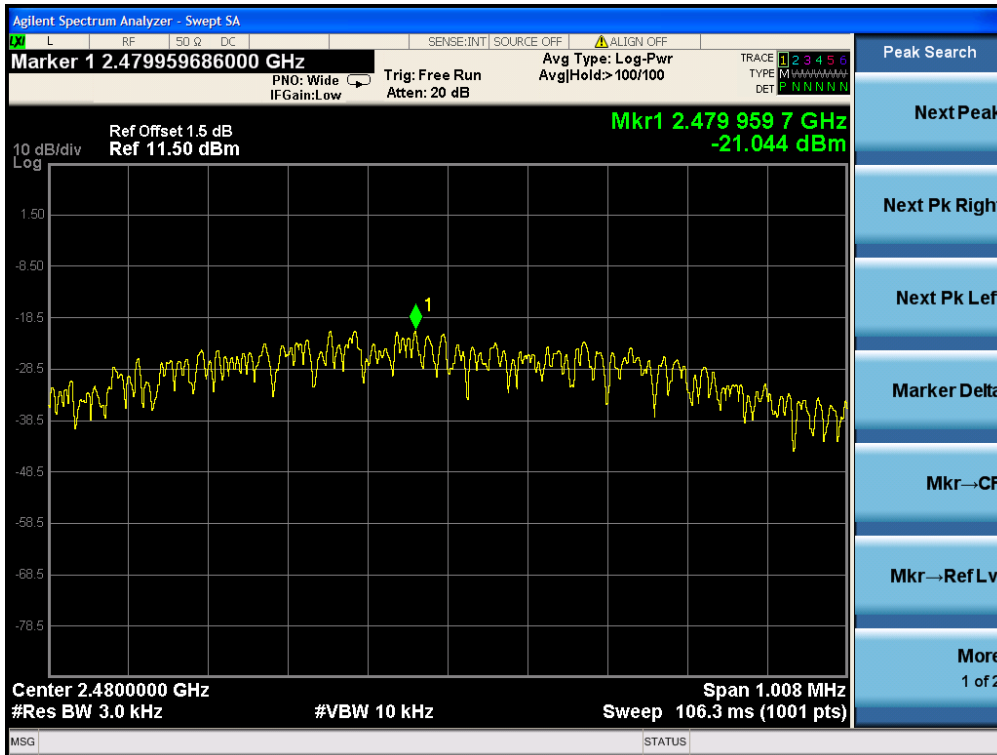

TEST REPORT

4.4 Out of Band Conducted Emissions

For GFSK, the maximum conducted (peak) output power was used to demonstrate compliance as described in 9.1. Then the display line (in red) shown in the following plots denotes the limit at 20dB below maximum measured in-band peak PSD level in 100 KHz bandwidth for GFSK.

The measurement procedures under sections 11 of KDB558074 D01 v04 (05-April-2017) were used.

Furthermore, delta measurement technique for measuring bandedge emissions was incorporated in the test of the edge at 2483.5MHz.

Limits:

All spurious emission and up to the tenth harmonic was measured and they were found to be at least for GFSK below the maximum measured in-band peak PSD level.

TEST REPORT

PLOTS OF OUT OF BAND CONDUCTED EMISSIONS

Lowest Channel, Plot A

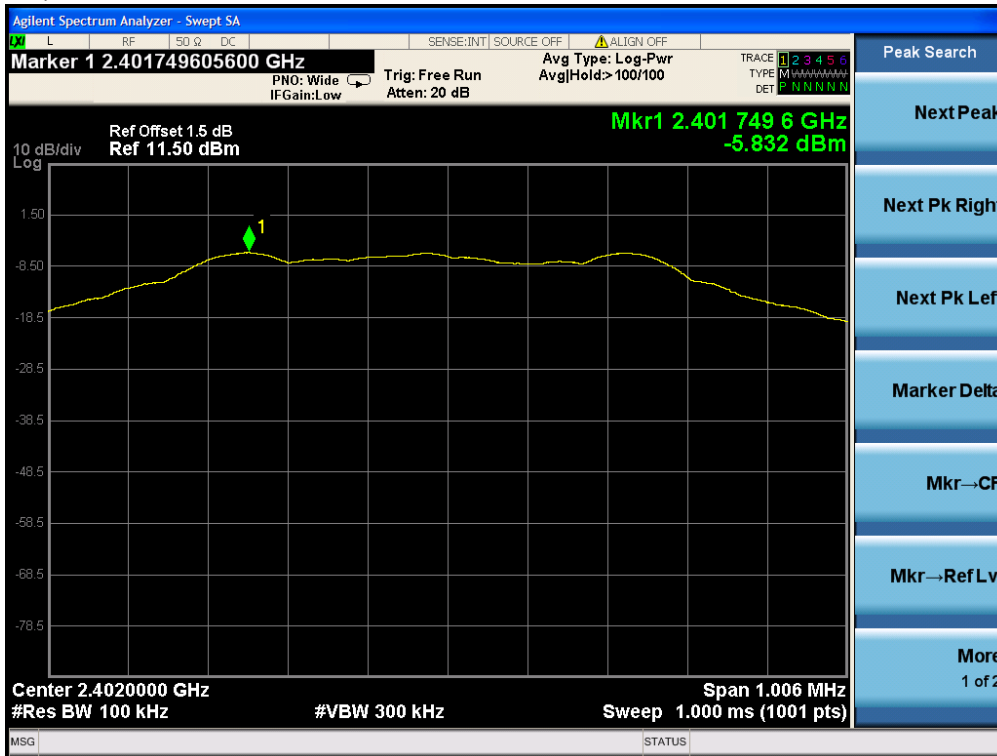

Lowest Channel, Plot B

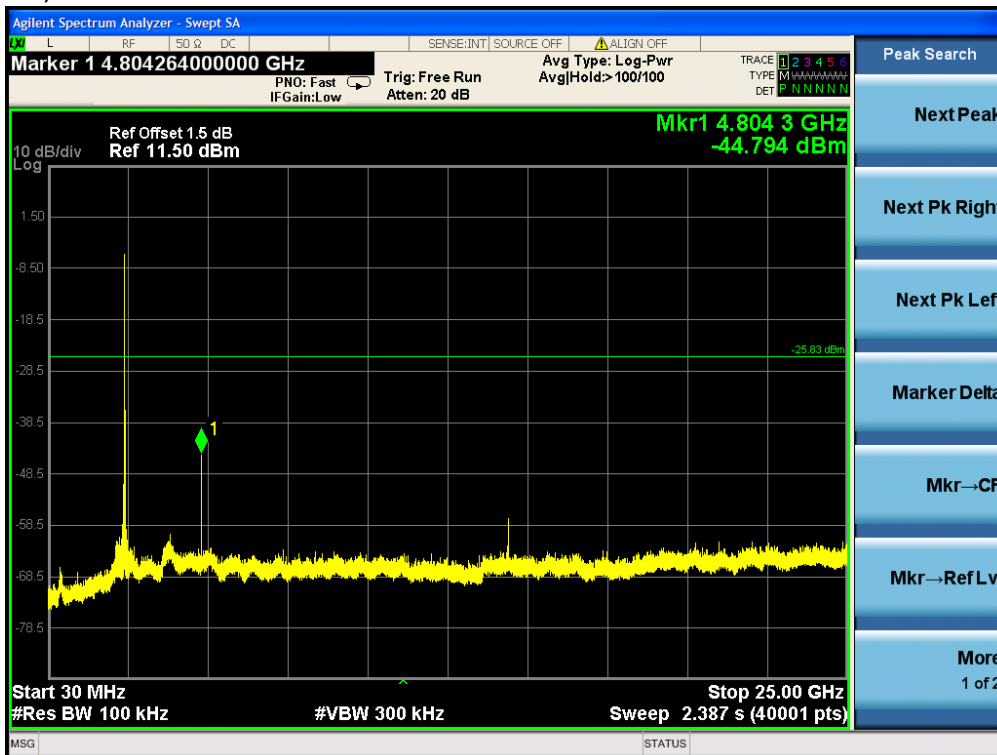

TEST REPORT

PLOTS OF OUT OF BAND CONDUCTED EMISSIONS

Middle Channel, Plot A

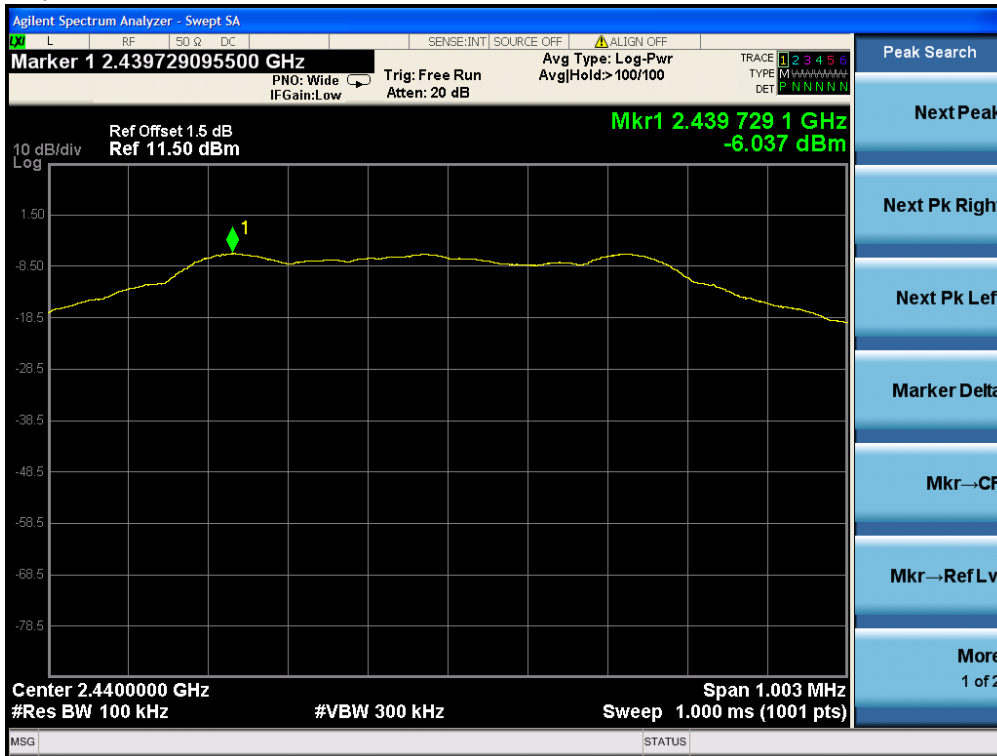

Middle Channel, Plot B

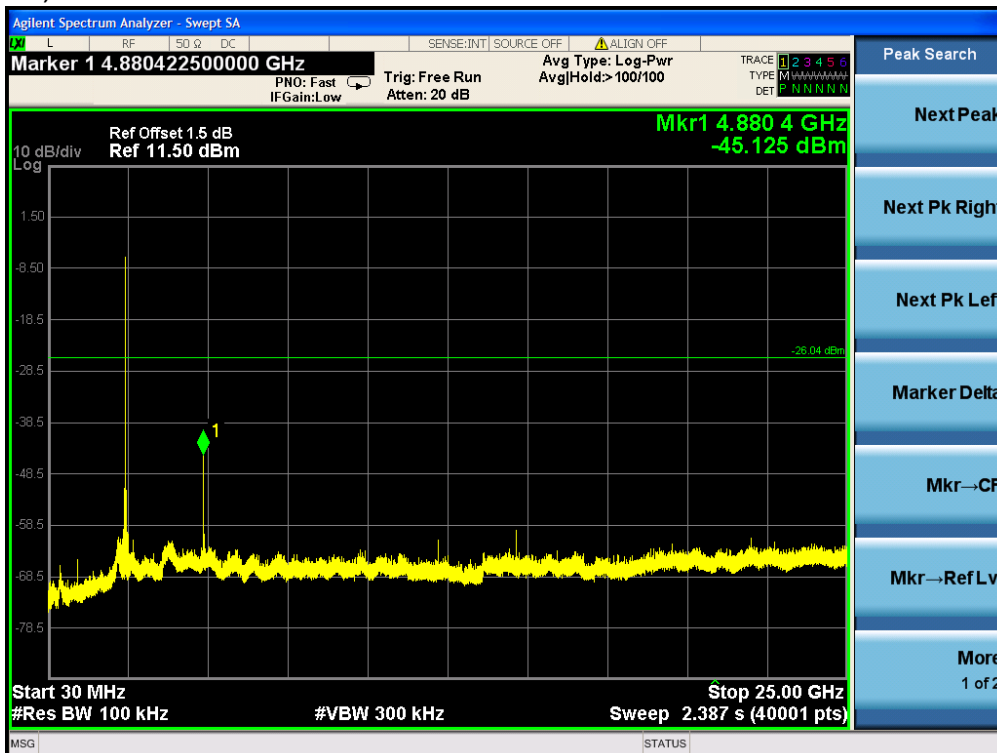

TEST REPORT

PLOTS OF OUT OF BAND CONDUCTED EMISSIONS

Highest Channel, Plot A

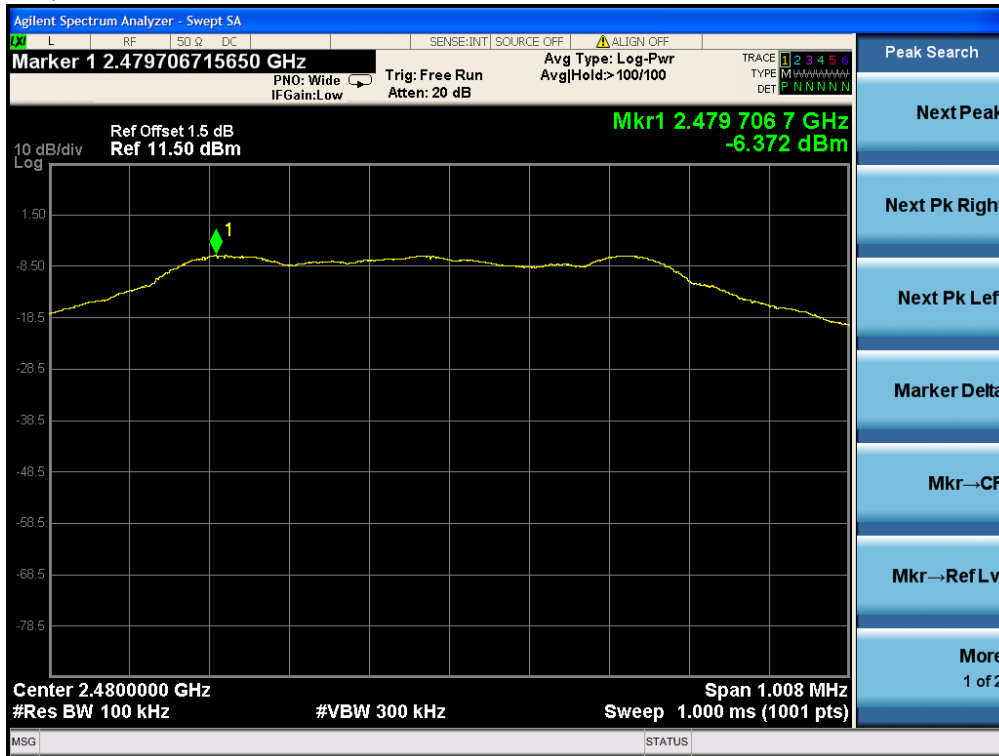

Highest Channel, Plot B

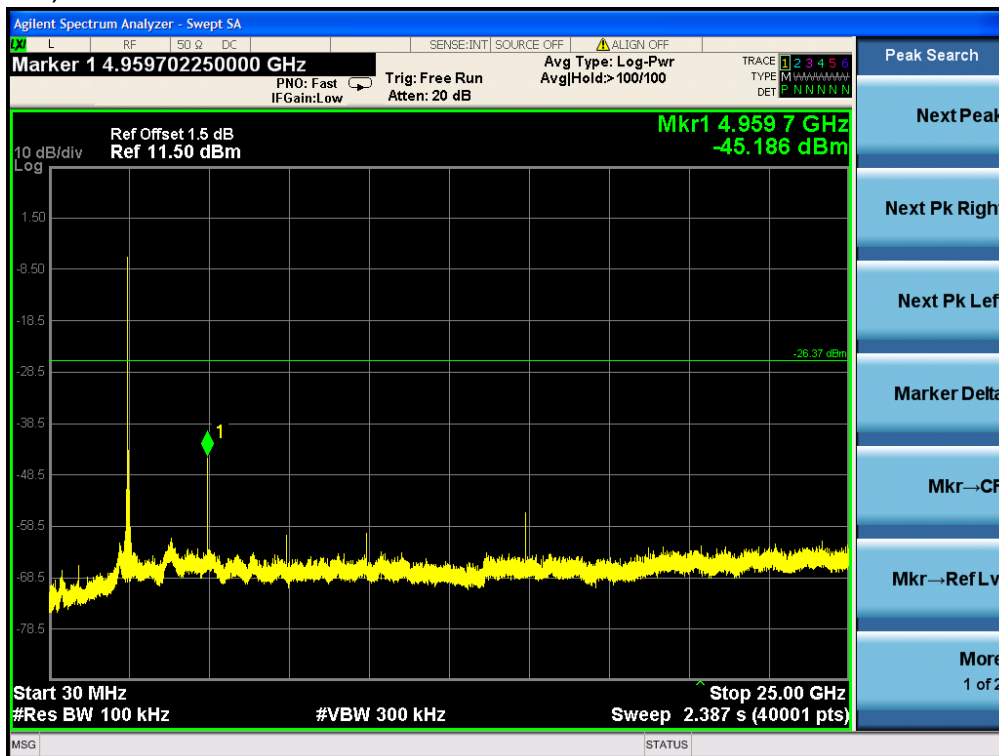

TEST REPORT

4.5 Field Strength Calculation

The field strength is calculated by adding the reading on the Spectrum Analyzer to the factors associated with preamplifiers (if any), antennas, cables, pulse desensitization and average factors (when specified limit is in average and measurements are made with peak detectors). A sample calculation is included below.

$$FS = RA + AF + CF - AG + PD + AV$$

Where FS = Field Strength in dB μ V/m

RA = Receiver Amplitude (including preamplifier) in dB μ V

CF = Cable Attenuation Factor in dB

AF = Antenna Factor in dB

AG = Amplifier Gain in dB

PD = Pulse Desensitization in dB

AV = Average Factor in -dB

In the radiated emission table which follows, the reading shown on the data table may reflect the preamplifier gain. An example of the calculations, where the reading does not reflect the preamplifier gain, follows:

$$FS = RA + AF + CF - AG + PD + AV$$

Example

Assume a receiver reading of 62.0 dB μ V is obtained. The antenna factor of 7.4 dB and cable factor of 1.6 dB is added. The amplifier gain of 29.0 dB is subtracted. The pulse desensitization factor of the spectrum analyzer is 0.0 dB, and the resultant average factor is -10.0 dB. The net field strength for comparison to the appropriate emission limit is 32.0 dB μ V/m. This value in dB μ V/m is converted to its corresponding level in μ V/m.

$$RA = 62.0 \text{ dB}\mu\text{V}$$

$$AF = 7.4 \text{ dB}$$

$$CF = 1.6 \text{ dB}$$

$$AG = 29.0 \text{ dB}$$

$$PD = 0.0 \text{ dB}$$

$$AV = -10 \text{ dB}$$

$$FS = 62.0 + 7.4 + 1.6 - 29.0 + 0.0 + (-10.0) = 32.0 \text{ dB}\mu\text{V/m}$$

$$\text{Level in } \mu\text{V/m} = \text{Common Antilogarithm } [(32.0 \text{ dB}\mu\text{V/m})/20] = 39.8 \mu\text{V/m}$$

TEST REPORT

4.6 Transmitter Radiated Emissions in Restricted Bands and Spurious Emissions

Data is included of the worst case configuration (the configuration which resulted in the highest emission levels). A sample calculation, configuration photographs and data tables of the emissions are included.

The data on the following pages list the significant emission frequencies, the limit and the margin of compliance.

4.6.1 Radiated Emission Configuration Photograph

Worst Case Restricted Band Radiated Emission
at

4880 and 4960 MHz

The worst case radiated emission configuration photographs are saved with filename: config photos.pdf

4.6.2 Radiated Emission Data

The data in tables 1-4 list the significant emission frequencies, the limit and the margin of compliance.

Judgement -

Passed by 1.8 dB margin

TEST REPORT

RADIATED EMISSION DATA

Mode: TX-Channel 00

Table 1
GFSK

Polarization	Frequency (MHz)	Reading (dBµV)	Pre-Amp Gain (dB)	Antenna Factor (dB)	Net at 3m (dBµV/m)	Average Limit at 3m (dBµV/m)	Margin (dB)
<i>V</i>	<i>2390.000</i>	<i>40.9</i>	<i>33</i>	<i>29.4</i>	<i>37.3</i>	<i>54.0</i>	<i>-16.7</i>
<i>H</i>	<i>4804.000</i>	<i>47.9</i>	<i>33</i>	<i>34.9</i>	<i>49.8</i>	<i>54.0</i>	<i>-4.2</i>

Polarization	Frequency (MHz)	Reading (dBµV)	Pre-Amp Gain (dB)	Antenna Factor (dB)	Net at 3m - Peak (dBµV/m)	Peak Limit at 3m (dBµV/m)	Margin (dB)
<i>V</i>	<i>2390.000</i>	<i>52.8</i>	<i>33</i>	<i>29.4</i>	<i>49.2</i>	<i>74.0</i>	<i>-24.8</i>
<i>H</i>	<i>4804.000</i>	<i>47.9</i>	<i>33</i>	<i>34.9</i>	<i>49.8</i>	<i>74.0</i>	<i>-24.2</i>

- NOTES:
1. Peak detector is used for the emission measurement.
 2. Average detector is used for the average data of emission measurement
 3. All measurements were made at 3 meters. Radiated emissions not detected at the 3-meter distance were measured at 0.3-meter and an inverse proportional extrapolation was performed to compare the signal level to the 3-meter limit. No other radiated emissions than those reported were detected at a test distance of 0.3-meter.
 4. Negative value in the margin column shows emission below limit.
 5. Horn antenna is used for the emission over 1000MHz.
 6. Emission (the row indicated by ***bold italic***) within the restricted band meets the requirement of FCC Part 15 Section 15.205 / RSS-Gen Section 8.10.
 7. For the measurement of radiated emission, summation method was used which numerical integrating (in terms of linear power) over the transmitter occupied bandwidth.
 8. For the linear power measurement, data in 1MHz spacing was collected by spectrum analyzer with 1MHz resolution bandwidth.

TEST REPORT

Mode: TX-Channel 19

Table 2
GFSK

Polarization	Frequency (MHz)	Reading (dBμV)	Pre-Amp Gain (dB)	Antenna Factor (dB)	Net at 3m (dBμV/m)	Average Limit at 3m (dBμV/m)	Margin (dB)
<i>H</i>	<i>4880.000</i>	<i>50.3</i>	<i>33</i>	<i>34.9</i>	<i>52.2</i>	<i>54.0</i>	<i>-1.8</i>
<i>H</i>	<i>7320.000</i>	<i>43.2</i>	<i>33</i>	<i>37.9</i>	<i>48.1</i>	<i>54.0</i>	<i>-5.9</i>

Polarization	Frequency (MHz)	Reading (dBμV)	Pre-Amp Gain (dB)	Antenna Factor (dB)	Net at 3m - Peak (dBμV/m)	Peak Limit at 3m (dBμV/m)	Margin (dB)
<i>H</i>	<i>4880.000</i>	<i>50.3</i>	<i>33</i>	<i>34.9</i>	<i>52.2</i>	<i>74.0</i>	<i>-21.8</i>
<i>H</i>	<i>7320.000</i>	<i>43.2</i>	<i>33</i>	<i>37.9</i>	<i>48.1</i>	<i>74.0</i>	<i>-25.9</i>

- NOTES:
1. Peak detector is used for the emission measurement.
 2. Average detector is used for the average data of emission measurement
 3. All measurements were made at 3 meters. Radiated emissions not detected at the 3-meter distance were measured at 0.3-meter and an inverse proportional extrapolation was performed to compare the signal level to the 3-meter limit. No other radiated emissions than those reported were detected at a test distance of 0.3-meter.
 4. Negative value in the margin column shows emission below limit.
 5. Horn antenna is used for the emission over 1000MHz.
 6. Emission (the row indicated by ***bold italic***) within the restricted band meets the requirement of FCC Part 15 Section 15.205 / RSS-Gen Section 8.10.
 7. For the measurement of radiated emission, summation method was used which numerical integrating (in terms of linear power) over the transmitter occupied bandwidth.
 8. For the linear power measurement, data in 1MHz spacing was collected by spectrum analyzer with 1MHz resolution bandwidth.

TEST REPORT

Mode: TX-Channel 39

Table 3
 GFSK

Polarization	Frequency (MHz)	Reading (dBμV)	Pre-Amp Gain (dB)	Antenna Factor (dB)	Net at 3m (dBμV/m)	Average Limit at 3m (dBμV/m)	Margin (dB)
<i>V</i>	<i>2483.500</i>	<i>41.5</i>	<i>33</i>	<i>29.4</i>	<i>37.9</i>	<i>54.0</i>	<i>-16.1</i>
<i>H</i>	<i>4960.000</i>	<i>50.3</i>	<i>33</i>	<i>34.9</i>	<i>52.2</i>	<i>54.0</i>	<i>-1.8</i>
<i>H</i>	<i>7440.000</i>	<i>44.2</i>	<i>33</i>	<i>37.9</i>	<i>49.1</i>	<i>54.0</i>	<i>-4.9</i>

Polarization	Frequency (MHz)	Reading (dBμV)	Pre-Amp Gain (dB)	Antenna Factor (dB)	Net at 3m - Peak (dBμV/m)	Peak Limit at 3m (dBμV/m)	Margin (dB)
<i>V</i>	<i>2483.500</i>	<i>53.1</i>	<i>33</i>	<i>29.4</i>	<i>49.5</i>	<i>74.0</i>	<i>-24.5</i>
<i>H</i>	<i>4960.000</i>	<i>50.3</i>	<i>33</i>	<i>34.9</i>	<i>52.2</i>	<i>74.0</i>	<i>-21.8</i>
<i>H</i>	<i>7440.000</i>	<i>44.2</i>	<i>33</i>	<i>37.9</i>	<i>49.1</i>	<i>74.0</i>	<i>-24.9</i>

- NOTES:
1. Peak detector is used for the emission measurement.
 2. Average detector is used for the average data of emission measurement
 3. All measurements were made at 3 meters. Radiated emissions not detected at the 3-meter distance were measured at 0.3-meter and an inverse proportional extrapolation was performed to compare the signal level to the 3-meter limit. No other radiated emissions than those reported were detected at a test distance of 0.3-meter.
 4. Negative value in the margin column shows emission below limit.
 5. Horn antenna is used for the emission over 1000MHz.
 6. Emission (the row indicated by ***bold italic***) within the restricted band meets the requirement of FCC Part 15 Section 15.205 / RSS-Gen Section 8.10.
 7. For the measurement of radiated emission, summation method was used which numerical integrating (in terms of linear power) over the transmitter occupied bandwidth.
 8. For the linear power measurement, data in 1MHz spacing was collected by spectrum analyzer with 1MHz resolution bandwidth.

TEST REPORT

Mode: Worst-Case Operating Mode: Normal Operation

Table 4

Polarization	Frequency (MHz)	Reading (dBµV)	Pre-amp (dB)	Antenna Factor (dB)	Net at 3m (dBµV/m)	Limit at 3m (dBµV/m)	Margin (dB)
V	34.850	30.5	16	10.0	24.5	40.0	-15.5
V	47.460	29.4	16	11.0	24.4	40.0	-15.7
V	286.080	13.7	16	22.0	19.7	46.0	-26.3
V	446.130	12.0	16	26.0	22.0	46.0	-24.0
V	604.240	9.7	16	29.0	22.7	46.0	-23.3
V	687.660	11.2	16	29.0	24.2	46.0	-21.8

- NOTES:
1. Peak detector is used for the emission measurement.
 2. All measurements were made at 3 meters. Radiated emissions not detected at the 3-meter distance were measured at 0.3-meter and an inverse proportional extrapolation was performed to compare the signal level to the 3-meter limit. No other radiated emissions than those reported were detected at a test distance of 0.3-meter.
 3. Negative value in the margin column shows emission below limit.
 4. Emission (the row indicated by ***bold italic***) within the restricted band meets the requirement of FCC Part 15 Section 15.205 / RSS-Gen Section 8.10.

TEST REPORT

4.6.3 Radiated Emission Test Setup

The figure below shows the test setup, which is utilized to make these measurements.

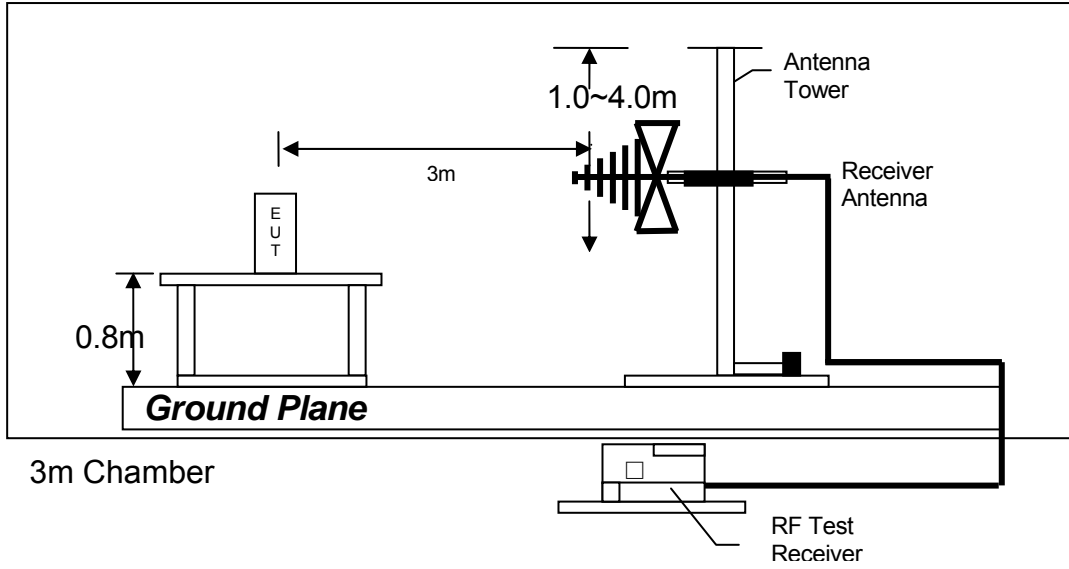

Test setup of radiated emissions up to 1GHz

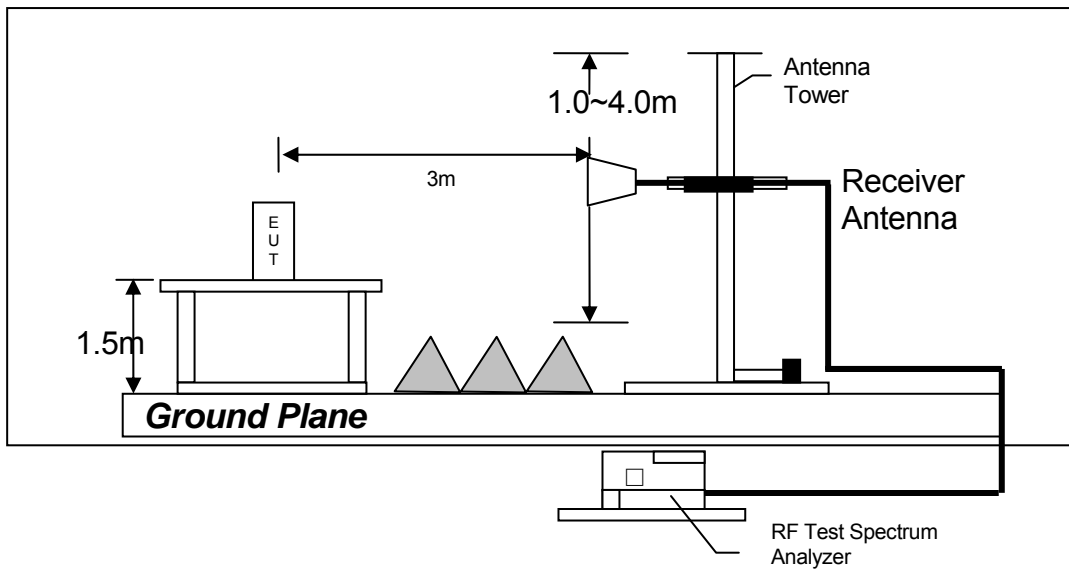

Test setup of radiated emissions above 1GHz

TEST REPORT

4.6.4 Transmitter Duty Cycle Calculation

Not applicable – No average factor is required.

TEST REPORT

EXHIBIT 5 EQUIPMENT LIST

5.0 EQUIPMENT LIST

1) Radiated Emissions Test

Equipment	EMI Test Receiver	Spectrum Analyzer	Broad-Band Horn Antenna
Registration No.	N/A	N/A	N/A
Manufacturer	Agilent	Agilent	Schwarzbeck
Model No.	E4446A	E4446A	BBHA 9170
Calibration Date	Feb. 17, 2017	Feb. 17, 2017	Feb. 11, 2017
Calibration Due Date	Feb. 16, 2018	Feb. 16, 2018	Feb. 10, 2018

Equipment	Log Periodic Antenna	High Noise Amplifier	Horn Antenna
Registration No.	N/A	EW-1133	N/A
Manufacturer	SCHAFFNER	Agilent	Schwarzbeck
Model No.	CBL6143	8449B	BBHA9120
Calibration Date	Feb. 12, 2017	Feb. 11, 2017	Feb. 12, 2017
Calibration Due Date	Feb. 11, 2018	Feb. 10, 2018	Feb. 11, 2018

2) Conductive Measurement Test

Equipment	Spectrum Analyzer
Registration No.	N/A
Manufacturer	Agilent
Model No.	E4446A
Calibration Date	Feb. 17, 2017
Calibration Due Date	Feb. 16, 2018