

TEST REPORT

Applicant: Binatone Electronics International Ltd.
Address of Applicant: Floor 23A, 9 Des Voeux Road West, Sheung Wan, Hong Kong, China

Equipment Under Test (EUT)

Product Name: Video Baby Monitor (Baby Unit)
Model Name.: MBP482NXLBU, MBP482NBU, MBP482BU
Trade mark: motorola
FCC ID: VLJ-MBP482NBU
Canada IC: 4522A-MBP482NBU
HVIN: MBP482NBU

Applicable standards: CFR47 FCC Part 15: Subpart C Section 15.247
CFR47 FCC Part 15: Subpart C Section 15.207
CFR47 FCC Part 15: Subpart C Section 15.209
CFR47 FCC Part 15: Subpart B Section 15.107
CFR47 FCC Part 15: Subpart B Section 15.109
RSS-247 Issue 2 February 2017
RSS-Gen Issue 5 April 2018
ICES-003 Issue 6 January 2016

Date of sample receipt: 08 May 2019
Date of Test: 08 May 2019 to 15 July 2019
Date of report issued: 18 July 2019
Test Result: PASS*

* In the configuration tested, the EUT complied with the standards specified above.

Authorized Signature:



Bruce Zhang
Laboratory Manager

This report details the results of the testing carried out on one sample. The results contained in this test report do not relate to other samples of the same product and does not permit the use of the CCIS product certification mark. The manufacturer should ensure that all products in series production are in conformity with the product sample detailed in this report.

This report may only be reproduced and distributed in full. If the product in this report is used in any configuration other than that detailed in the report, the manufacturer must ensure the new system complies with all relevant standards.

This document cannot be reproduced except in full, without prior written approval of the Company. Any unauthorized alteration, forgery or falsification of the content or appearance of this document is unlawful and offenders may be prosecuted to the fullest extent of the law. Unless otherwise stated the results shown in this test report refer only to the sample(s) tested and such sample(s) are retained for 90 days only.

Revision History

Rev.	Issue Date	Report NO.	Effect Page	Contents
00	18 July 2019	CCISE190708602	ALL	Initial Issue

Tested by:

Carrey Chen

Date:

08 May 2019 - 15 July 2019

Test Engineer

Reviewed by:

Wimer Zhang

Date:

18 July 2019

Project Engineer

Table of Contents		Page
1	SUMMARY OF TEST RESULTS	5
1.1	TEST FACTORY.....	6
1.2	MEASUREMENT UNCERTAINTY	6
2	GENERAL INFORMATION	7
2.1	GENERAL DESCRIPTION OF EUT	7
2.2	DESCRIPTION OF TEST MODES	9
2.3	BLOCK DIGRAM SHOWING THE CONFIGURATION OF SYSTEM TESTED	10
2.4	DESCRIPTION OF NECESSARY ACCESSORIES AND SUPPORT UNITS	10
2.5	EQUIPMENTS LIST	11
3	EMC EMISSION TEST	12
3.1	CONDUCTED EMISSION MEASUREMENT	12
3.2	RADIATED EMISSION MEASUREMENT.....	18
3.3	RADIATED SPURIOUS EMISSION MEASUREMENT	24
4	CONDUCTED SPURIOUS & BAND EDGE EMISSION	38
4.1	APPLIED PROCEDURES / LIMIT	38
4.2	TEST PROCEDURE	38
4.3	DEVIATION FROM STANDARD	38
4.4	TEST SETUP.....	38
4.5	EUT OPERATION CONDITIONS.....	38
4.6	TEST RESULTS.....	39
5	NUMBER OF HOPPING CHANNEL	43
5.1	APPLIED PROCEDURES / LIMIT	43
5.2	TEST PROCEDURE	43
5.3	DEVIATION FROM STANDARD	43
5.4	TEST SETUP.....	43
5.5	EUT OPERATION CONDITIONS.....	43
5.6	TEST RESULTS.....	44
6	AVERAGE TIME OF OCCUPANCY	45
6.1	APPLIED PROCEDURES / LIMIT	45
6.2	TEST PROCEDURE	45
6.3	DEVIATION FROM STANDARD	45
6.4	TEST SETUP.....	45
6.5	EUT OPERATION CONDITIONS.....	45

- 6.6 TEST RESULTS.....46
- 7 HOPPING CHANNEL SEPARATION MEASUREMENTS50**
 - 7.1 APPLIED PROCEDURES / LIMIT50
 - 7.2 TEST PROCEDURE50
 - 7.3 DEVIATION FROM STANDARD50
 - 7.4 TEST SETUP.....50
 - 7.5 EUT OPERATION CONDITIONS.....50
 - 7.6 TEST RESULTS.....51
- 8 BANDWIDTH TEST53**
 - 8.1 APPLIED PROCEDURES / LIMIT53
 - 8.2 TEST PROCEDURE53
 - 8.3 DEVIATION FROM STANDARD53
 - 8.4 TEST SETUP.....53
 - 8.5 EUT OPERATION CONDITIONS.....53
 - 8.6 TEST RESULTS.....54
- 9 PEAK OUTPUT POWER TEST56**
 - 9.1 APPLIED PROCEDURES / LIMIT56
 - 9.2 TEST PROCEDURE56
 - 9.3 DEVIATION FROM STANDARD56
 - 9.4 TEST SETUP.....56
 - 9.5 EUT OPERATION CONDITIONS.....56
 - 9.6 TEST RESULTS.....57
- 10 ANTENNA REQUIREMENT58**
 - 10.1 STANDARD REQUIREMENT58
 - 10.2 EUT ANTENNA58
- 11 APPENDIX - PHOTOS OF TEST SETUP59**

1 SUMMARY OF TEST RESULTS

Test procedures according to the technical standards:

KDB 558074 D01 DTS Meas Guidance v05

FCC Part 15, Subpart C RSS-247 Issue 2			
Standard Section	Test Item	Judgment	Remark
FCC Part 15.207(a) RSS-Gen Clause 8.8	Conducted Emission	PASS	
FCC Part 15.247(a)(1) RSS-247 Clause 5.1(a)	20dB Bandwidth	PASS	
RSS-Gen Clause 6.7	99% Bandwidth	PASS	
FCC Part 15.247(a)(1) RSS-247 Clause 5.4(b)	Output Power	PASS	
FCC Part 15.247(d) RSS-247 Clause 3.3	Radiated Spurious Emission	PASS	
FCC Part 15.247(d) RSS-247 Clause 5.5	Conducted Spurious & Band Edge Emission	PASS	
FCC Part 15.247(a)(1) RSS-247 Clause 5.1(b)	Hopping Channel Separation	PASS	
FCC Part 15.247(a)(1) RSS-247 Clause 5.1(d)	Number of Hopping Frequency	PASS	
FCC Part 15.247(a)(1) RSS-247 Clause 5.1(d)	Dwell Time	PASS	
FCC Part 15.205	Restricted Band Edge Emission	PASS	
FCC Part 15.247(d) & 15.209(a) RSS-247 Clause 5.5	Band Edge Emission	PASS	
FCC Part 15.247(b)(4) & 15.203	Antenna Requirement	PASS	
RSS-Gen Clause 6.11	Frequency Stability	PASS	

FCC Part 15, Subpart B ICES-003 Issue 6			
StandardSection	Test Item	Judgment	Remark
FCC Part 15.107(a) ICES-003	Conducted Emission	PASS	Class B limit
FCC Part 15.109(a) ICES-003	Radiated Emission	PASS	Class B limit

NOTE:

- 1) 'N/A' denotes test is not applicable in this test report
- 2) All tests were performed according to the procedures in ANSI C63.10: 2013 and ANSI C63.4: 2014.

1.1 TEST FACTORY

Shenzhen Zhongjian Nanfang Testing Co., Ltd.
 Address: No. B-C, 1/F., Building 2, Laodong No.2 Industrial Park, Xixiang Road,
 Bao'an District, Shenzhen, Guangdong, China
 Tel: +86-755-23118282, Fax: +86-755-23116366
 Email: info@ccis-cb.com, Website: http://www.ccis-cb.com

The test facility is recognized, certified, or accredited by the following organizations:

- FCC - Designation No.: CN1211

Shenzhen Zhongjian Nanfang Testing Co., Ltd. has been accredited as a testing laboratory by FCC(Federal Communications Commission). The test firm Registration No. is 727551.

- ISED - CAB identifier.: CN0021

The 3m Semi-anechoic chamber of Shenzhen Zhongjian Nanfang Testing Co., Ltd. has been Registered by Certification and Engineering Bureau of Industry Canada for radio equipment testing with Registration No.: 10106A-1.

- CNAS - Registration No.: CNAS L6048

Shenzhen Zhongjian Nanfang Testing Co., Ltd. is accredited to ISO/IEC 17025:2005 General Requirements for the Competence of Testing and Calibration laboratories for the competence of testing. The Registration No. is CNAS L6048.

A2LA - Registration No.: 4346.01

This laboratory is accredited in accordance with the recognized International Standard ISO/IEC 17025:2005 General requirements for the competence of testing and calibration laboratories.

The test scope can be found as below link: <https://portal.a2la.org/scopepdf/4346-01.pdf>

1.2 MEASUREMENT UNCERTAINTY

Parameters	Expanded Uncertainty
Conducted Emission (9kHz ~ 30MHz)	±2.22 dB (k=2)
Radiated Emission (9kHz ~ 30MHz)	±2.76 dB (k=2)
Radiated Emission (30MHz ~ 1000MHz)	±4.28 dB (k=2)
Radiated Emission (1GHz ~ 18GHz)	±5.72 dB (k=2)
Radiated Emission (18GHz ~ 40GHz)	±2.88 dB (k=2)

2 GENERAL INFORMATION

2.1 GENERAL DESCRIPTION OF EUT

Product Name	Video Baby Monitor (Baby Unit)	
Trade Name	motorola	
Model Name	MBP482NXLBU,	
Series Model	MBP482NBU, MBP482BU	
Model Difference	All models are fully identical except model name.	
Product Description	The EUT is a Video Baby Monitor (Baby Unit) which supports 2.4GHz FHSS wireless technology.	
	Operation Frequency:	2405 – 2475 MHz
	Modulation Type:	FSK
	Bit Rate of Transmitter:	2MHz, 2.5MHz, 3MHz, 4MHz, 4.5MHz
	Number Of Channel:	32 channels (16 active channels)
	Antenna Designation:	Please see Note 4
	Antenna Gain (dBi):	0 dBi
Channel List	Please refer to the Note 2.	
Adapter	Model: S003GU0600050 (Tenpao) Input: AC 100-240V~50/60Hz 150mA Output: DC 6.0V@0.5A	
Battery	N/A	
Hardware version	N/A	
Software version	N/A	
Radio Hardware version	N/A	
Radio Software version	N/A	
Test Software	SecureCRT	
RF Power Setting TEST Software (power class)	1	
Connecting I/O Port(s)	Please refer to the User's Manual	

Note:

- 1 For a more detailed features description, please refer to the manufacturer's specifications or the User's Manual.

2

RF Channel and Frequency			
RF Channel	Freq.(MHz)	RF Channel	Freq.(MHz)
01	2405.00	17	2439.00
02	2407.00	18	2441.00
03	2409.00	19	2444.00
04	2411.00	20	2446.00
05	2413.00	21	2450.00
06	2415.00	22	2452.00
07	2418.00	23	2454.00
08	2420.00	24	2456.00
09	2422.00	25	2458.50
10	2424.00	26	2460.50
11	2426.00	27	2462.50
12	2428.00	28	2467.00
13	2430.00	29	2469.00
14	2433.00	30	2471.00
15	2435.00	31	2473.00
16	2437.00	32	2475.00

3 Note:

- 1) In section 15.31(m), regards to the operating frequency range over 10 MHz, the Lowest frequency, the middle frequency, and the highest frequency of channel were selected to perform the test;
- 2) Test frequencies are lowest channel: 2405 MHz, middle channel: 2439 MHz and highest channel: 2475 MHz

4

Ant	Brand	Model Name	Antenna Type	Connector	Gain (dBi)	NOTE
1	motorola	MBP482NXLBU	Integral Antenna	N/A	0	2.4G Antenna

2.2 DESCRIPTION OF TEST MODES

Each of these EUT operation mode(s) or test configuration mode(s) mentioned above was evaluated respectively.

Worst Mode	Description	Data Rate
Mode 1	TX GFSK LOW CHANNEL	/
Mode 2	TX GFSK MID CHANNEL	/
Mode 3	TX GFSK HIGH CHANNEL	/
Mode 4	Transmitting mode	/
Mode 5	Charging mode	/

Note:

- 1) The measurements are performed at all Bit Rate of Transmitter, the worst data was reported
- 2) We have be tested for all avaiable U.S. voltage and frequencies(For 120V,50/60Hz and 240V, 50/60Hz) for which the device is capable of operation , and the worst case of 120V/60Hz is shown in the report
- 3) Controlled using a bespoke application on the laptop PC supplied by the customer. The application was used to enable a continuous transmission mode and to select the test channels, data rates and modulation schemes as required.

2.3 BLOCK DIGRAM SHOWING THE CONFIGURATION OF SYSTEM TESTED

Radiation Test Set

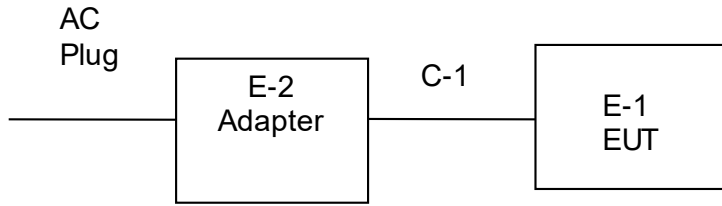

Conduction Test Set

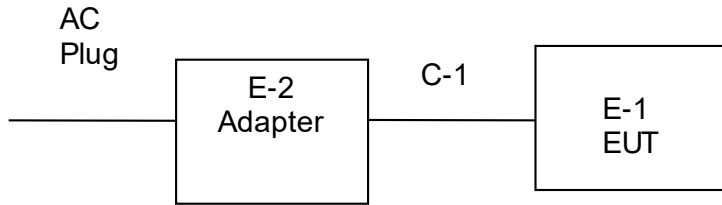

2.4 DESCRIPTION OF NECESSARY ACCESSORIES AND SUPPORT UNITS

The EUT has been tested as an independent unit together with other necessary accessories or support units. The following support units or accessories were used to form a representative test configuration during the tests.

Item	Equipment	Mfr/Brand	Model/Type No.	Serial No.	Note
E-2	Adapter	Tenpao	S003GU0600050	N/A	Accessories Equipment

Item	Shielded Type	Ferrite Core	Length	Note
C-1	Adapter DC Cable	NO	180cm	N/A

Note:

- 1) The support equipment was authorized by Declaration of Confirmation.
- 2) For detachable type I/O cable should be specified the length in cm in 『Length』 column.
- 3) “YES” is means “shielded” “with core”; “NO” is means “unshielded” “without core”.

2.5 EQUIPMENTS LIST

Radio Spectrum Testing				
Equipment	Manufacturer	Model No.	Serial No.	Cal. Until
USB RF power sensor	DARE	RPR3006W	15I00041SNO09	05.03.2020
Spectrum analyzer	Agilent	N9020A	MY51110123	01.03.2020
Spurious Emission				
Equipment	Manufacturer	Model No.	Serial No.	Cal. Until
Loop Antenna	Schwarzbeck	FMZB1519B	00044	14.03.2020
Bilog Antenna	Schwarzbeck	VULB9163	497	14.03.2020
Horn Antenna	Schwarzbeck	BBHA 9120D	1805	21.06.2020
SHF-EHF Horn Antenna	Schwarzbeck	BBHA 9170	BBHA9170582	20.11.2019
Pre-amplifier	HP	8447D	2944A09358	05.03.2020
Pre-amplifier	CD	PAP-1G18	11804	05.03.2020
EMI Test Receiver	R&S	ESRP7	101070	05.03.2020
Spectrum analyzer	R&S	FSP30	101454	05.03.2020
Spectrum analyzer	R&S	FSP40	100363	05.03.2020
Cable	ZDECL	Z108-NJ-NJ-81	1608458	05.03.2020
Cable	MICRO-COAX	MFR64639	K10742-5	05.03.2020
Cable	SUHNER	SUCOFLEX100	58193/4PE	05.03.2020
Conducted Emission on AC Mains				
Equipment	Manufacturer	Model No.	Serial No.	Cal. Until
EMI Test Receiver	R&S	ESCI	101189	05.03.2020
Pulse Limiter	Schwarzbeck	OSRAM 2306	9731	05.03.2020
LISN	CHASE	MN2050D	1447	17.03.2020
LISN	R&S	ESH3-Z5	8438621/010	20.07.2019

3 EMC EMISSION TEST

3.1 CONDUCTED EMISSION MEASUREMENT

3.1.1 POWER LINE CONDUCTED EMISSION LIMITS

operating frequency band. In case the emission fall within the restricted band specified on Part 15. 207(a), 107(a), RSS-Gen Table3 and ICES-003 Table2 limit in the table below has to be followed. This item was performed according to the procedures in ANSI C63.10: 2013 and ANSI C63.4: 2014.

FREQUENCY (MHz)	Conducted Emission limit (dBuV)	
	Quasi-peak	Average
0.15 -0.5	66 - 56 *	56 - 46 *
0.50 -5.0	56.00	46.00
5.0 -30.0	60.00	50.00

Note:

- 1) The tighter limit applies at the band edges.
- 2) The limit of " * " marked band means the limitation decreases linearly with the logarithm of the frequency in the range.

The following table is the setting of the receiver

Receiver Parameters	Setting
Attenuation	10 dB
Start Frequency	0.15 MHz
Stop Frequency	30 MHz
IF Bandwidth	9 kHz

3.1.2 TEST PROCEDURE

- a. The EUT was 0.8 meters from the horizontal ground plane and 0.4 meters from the vertical ground plane with EUT being connected to the power mains through a line impedance stabilization network (LISN). All other support equipments powered from additional LISN(s). The LISN provide 50 Ohm/ 50uH of coupling impedance for the measuring instrument.
- b. Interconnecting cables that hang closer than 40 cm to the ground plane shall be folded back and forth in the center forming a bundle 30 to 40 cm long.
- c. I/O cables that are not connected to a peripheral shall be bundled in the center. The end of the cable may be terminated, if required, using the correct terminating impedance. The overall length shall not exceed 1 m.
- d. LISN at least 80 cm from nearest part of EUT chassis.
- e. For the actual test configuration, please refer to the related Item –EUT Test Photos.

3.1.3 TEST SETUP

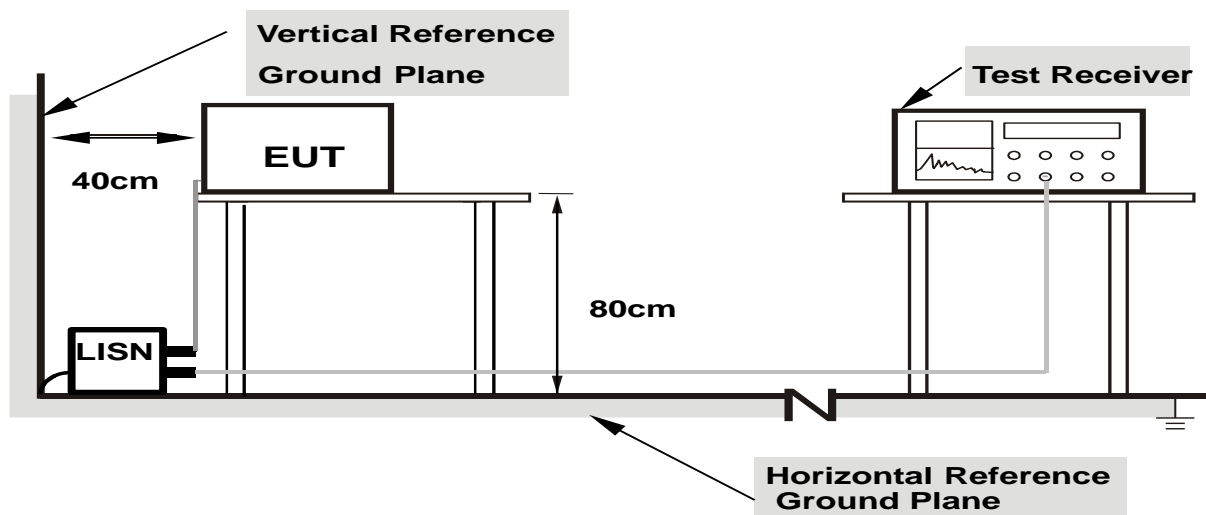

- Note: 1.Support units were connected to second LISN.**
2.Both of LISNs (AMN) are 80 cm from EUT and at least 80 from other units and other metal planes

3.1.4 EUT OPERATING CONDITIONS

The EUT was configured for testing in a typical fashion (as a customer would normally use it). The EUT has been programmed to continuously transmit during test. This operating condition was tested and used to collect the included data.

3.1.5 TEST RESULT

Temperature:	24 °C	Relative Humidity:	66%
Test Voltage:	AC 120V/60Hz	Phase:	L
Test Mode:	Mode 4	Test Date:	2019-07-11
Note:	Adapter(Tenpao)		

Frequency (MHz)	Reading (dBuV)	Correct Factor(dB)	Result (dBuV)	Limit (dBuV)	Margin (dB)	Remark
0.2940	20.82	20.69	41.51	60.41	-18.90	QP
0.2940	1.65	20.69	22.34	50.41	-28.07	AVG
0.3740	19.92	20.55	40.47	58.41	-17.94	QP
0.3740	2.85	20.55	23.40	48.41	-25.01	AVG
1.2700	25.41	20.13	45.54	56.00	-10.46	QP
1.2700	10.17	20.13	30.30	46.00	-15.70	AVG
2.1060	23.87	20.05	43.92	56.00	-12.08	QP
2.1060	9.48	20.05	29.53	46.00	-16.47	AVG
3.1020	26.82	19.97	46.79	56.00	-9.21	QP
3.1020	13.04	19.97	33.01	46.00	-12.99	AVG
10.8260	18.23	20.11	38.34	60.00	-21.66	QP
10.8260	3.48	20.11	23.59	50.00	-26.41	AVG

Remark:

1. All readings are Quasi-Peak and Average values.
2. Margin = Result (Result = Reading + Factor) – Limit

100.0 dBuV

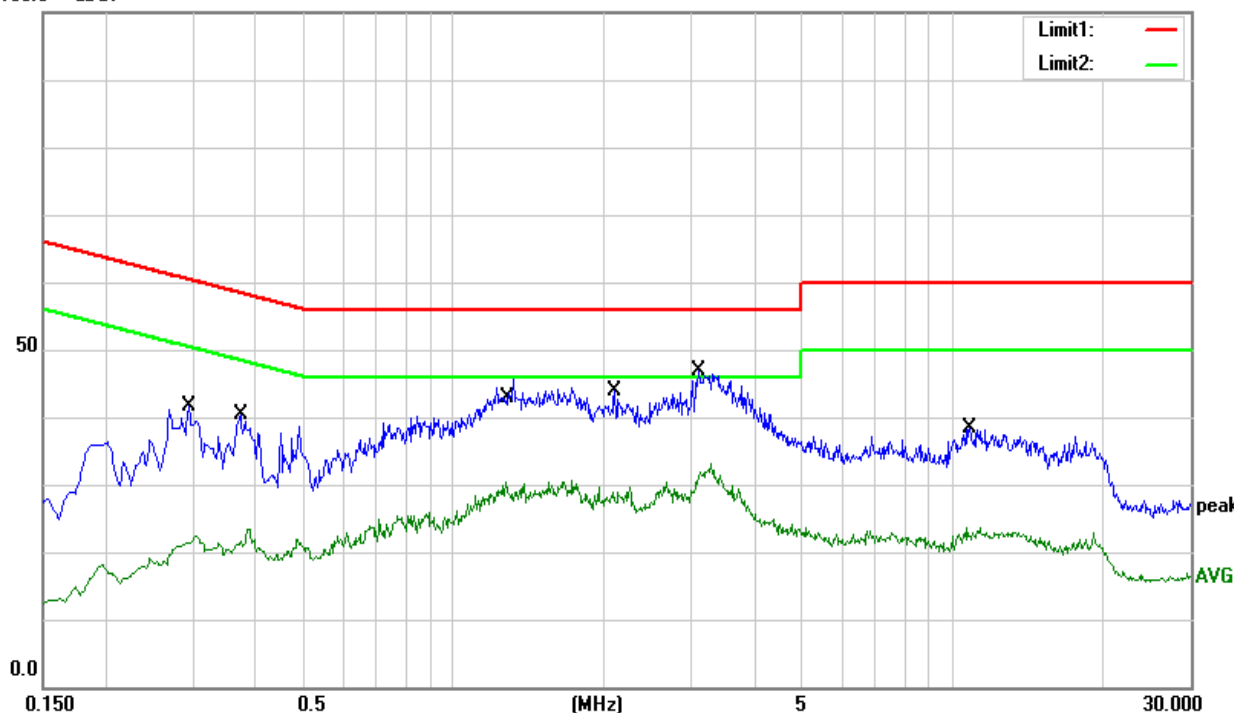

Temperature:	24 °C	Relative Humidity:	66%
Test Voltage:	AC 120V/60Hz	Phase:	N
Test Mode:	Mode 4	Test Date:	2019-07-11
Note:	Adapter(Tenpao)		

Frequency (MHz)	Reading (dBuV)	Correct Factor(dB)	Result (dBuV)	Limit (dBuV)	Margin (dB)	Remark
0.3620	26.32	20.58	46.90	58.68	-11.78	QP
0.3620	17.06	20.58	37.64	48.68	-11.04	AVG
0.4860	21.47	20.48	41.95	56.24	-14.29	QP
0.4860	11.08	20.48	31.56	46.24	-14.68	AVG
0.9900	25.29	20.16	45.45	56.00	-10.55	QP
0.9900	12.08	20.16	32.24	46.00	-13.76	AVG
1.4660	23.83	20.11	43.94	56.00	-12.06	QP
1.4660	9.97	20.11	30.08	46.00	-15.92	AVG
3.2980	24.79	19.98	44.77	56.00	-11.23	QP
3.2980	9.12	19.98	29.10	46.00	-16.90	AVG
5.5220	14.02	19.92	33.94	60.00	-26.06	QP
5.5220	1.85	19.92	21.77	50.00	-28.23	AVG

Remark:

1. All readings are Quasi-Peak and Average values.
2. Margin = Result (Result = Reading + Factor) – Limit

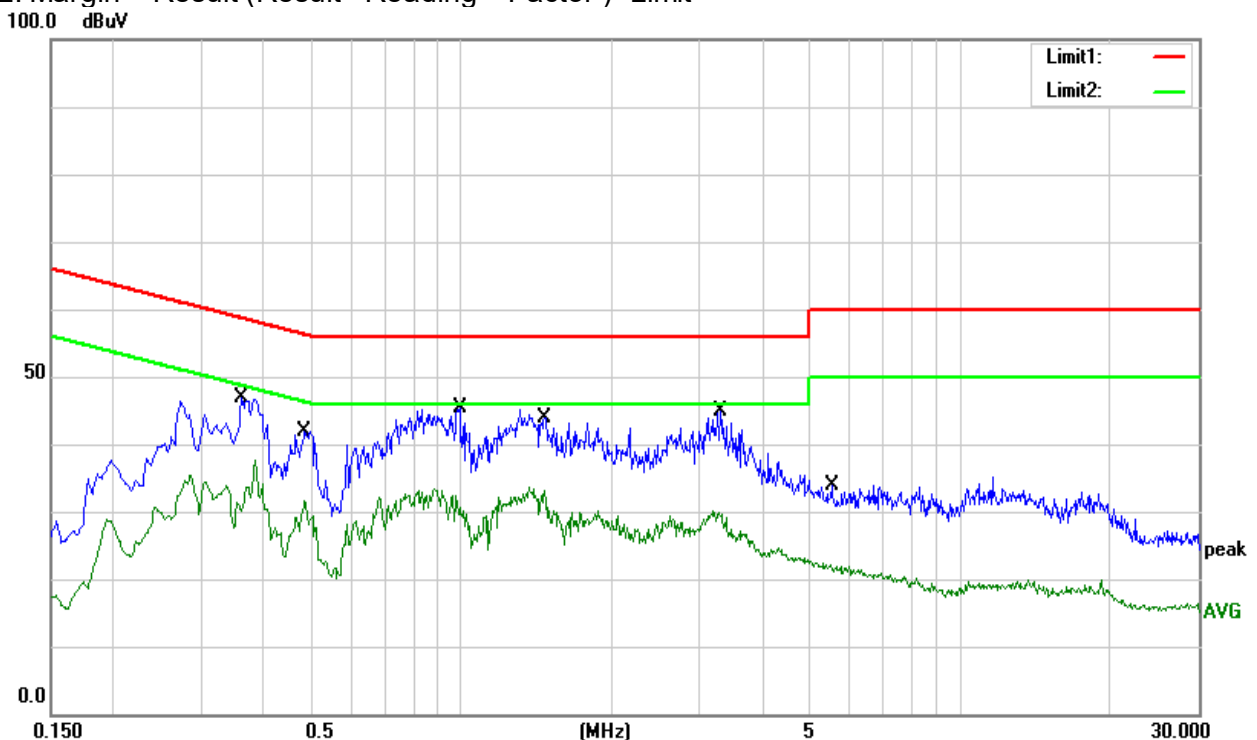

Temperature:	24 °C	Relative Humidity:	66%
Test Voltage:	AC 120V/60Hz	Phase:	L
Test Mode:	Mode 5 (Part 15B & ICES-003)	Test Date:	2019-07-11
Note:	Adapter(Tenpao)		

Frequency (MHz)	Reading (dBuV)	Correct Factor(dB)	Result (dBuV)	Limit (dBuV)	Margin (dB)	Remark
0.3980	18.56	20.49	39.05	57.90	-18.85	QP
0.3980	11.91	20.49	32.40	47.90	-15.50	AVG
0.9220	13.73	20.18	33.91	56.00	-22.09	QP
0.9220	4.44	20.18	24.62	46.00	-21.38	AVG
1.9700	16.76	20.06	36.82	56.00	-19.18	QP
1.9700	4.17	20.06	24.23	46.00	-21.77	AVG
4.7980	14.32	19.95	34.27	56.00	-21.73	QP
4.7980	3.59	19.95	23.54	46.00	-22.46	AVG
14.3980	14.99	19.99	34.98	60.00	-25.02	QP
14.3980	3.46	19.99	23.45	50.00	-26.55	AVG
19.1980	14.55	19.95	34.50	60.00	-25.50	QP
19.1980	4.06	19.95	24.01	50.00	-25.99	AVG

Remark:

1. All readings are Quasi-Peak and Average values.
2. Margin = Result (Result =Reading + Factor)–Limit

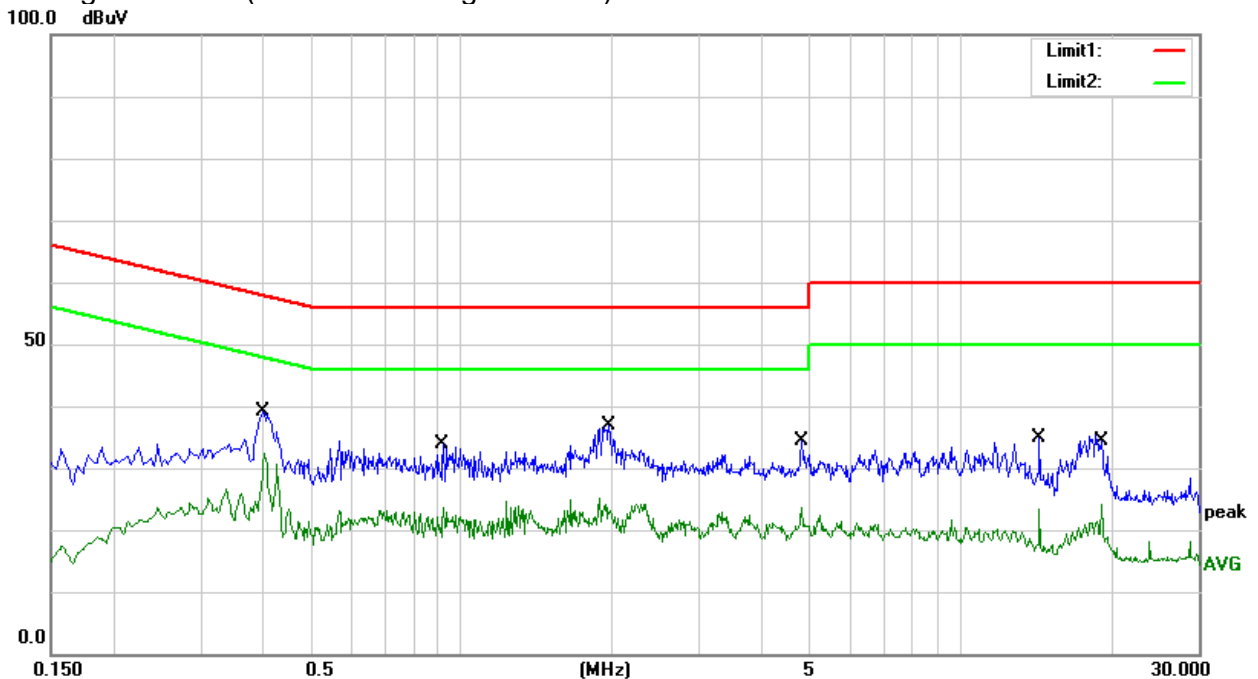

Temperature:	24 °C	Relative Humidity:	66%
Test Voltage:	AC 120V/60Hz	Phase:	N
Test Mode:	Mode 5 (Part 15B & ICES-003)	Test Date:	2019-07-11
Note:	Adapter(Tenpao)		

Frequency (MHz)	Reading (dBuV)	Correct Factor(dB)	Result (dBuV)	Limit (dBuV)	Margin (dB)	Remark
0.3620	26.22	20.58	46.80	58.68	-11.88	QP
0.3620	16.96	20.58	37.54	48.68	-11.14	AVG
0.4860	21.37	20.48	41.85	56.24	-14.39	QP
0.4860	10.98	20.48	31.46	46.24	-14.78	AVG
0.9900	25.19	20.16	45.35	56.00	-10.65	QP
0.9900	11.98	20.16	32.14	46.00	-13.86	AVG
1.4660	23.73	20.11	43.84	56.00	-12.16	QP
1.4660	9.87	20.11	29.98	46.00	-16.02	AVG
3.2980	24.69	19.98	44.67	56.00	-11.33	QP
3.2980	9.02	19.98	29.00	46.00	-17.00	AVG
5.5220	13.92	19.92	33.84	60.00	-26.16	QP
5.5220	1.75	19.92	21.67	50.00	-28.33	AVG

Remark:

1. All readings are Quasi-Peak and Average values.
2. Margin = Result (Result =Reading + Factor)–Limit

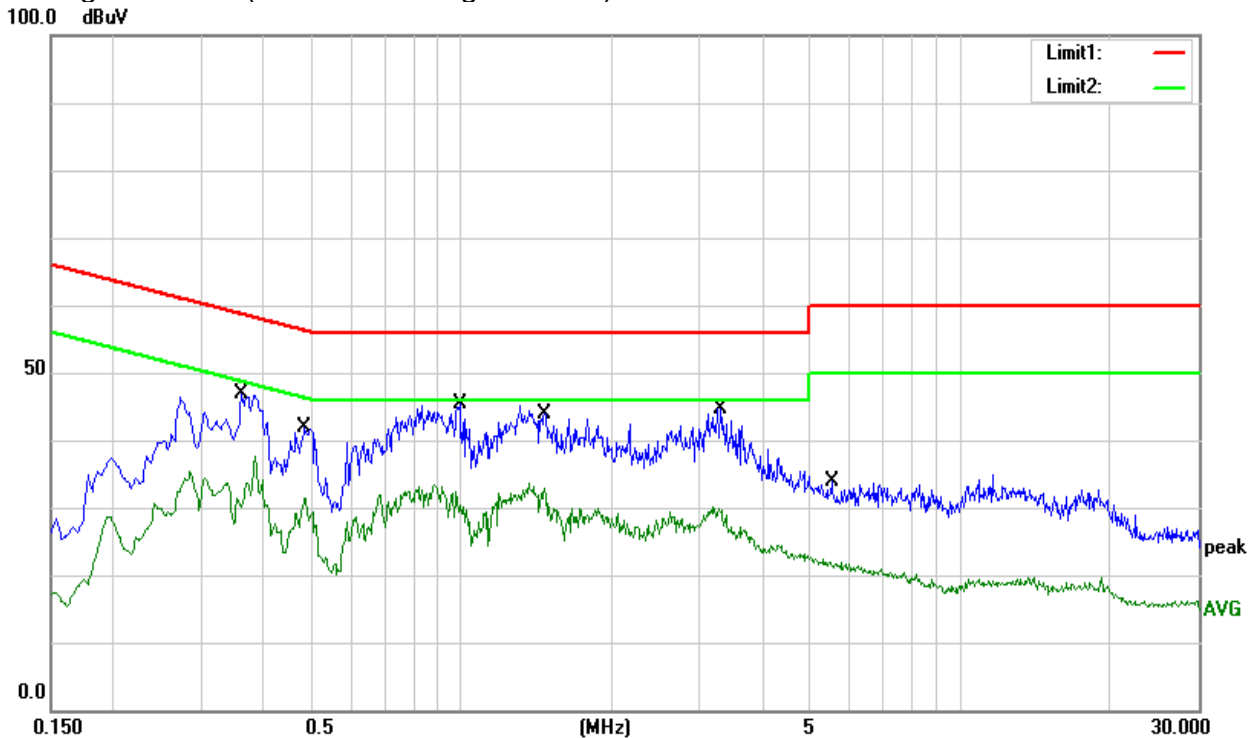

3.2 RADIATED EMISSION MEASUREMENT

3.2.1 RADIATED EMISSION LIMITS

Frequencies (MHz)	Class A (at 10m) dBuV/m	Class B (at 3m) dBuV/m
30~88	39.0	40.0
88~216	43.5	43.5
216~960	46.5	46.0
Above 960	49.5	54.0

LIMITS OF RADIATED EMISSION MEASUREMENT (Above 1000MHz)

FREQUENCY (MHz)	Class A (dBuV/m) (at 3M)		Class B (dBuV/m) (at 3M)	
	PEAK	AVERAGE	PEAK	AVERAGE
Above 1000	80	60	74	54

Note:

- 1) The tighter limit applies at the band edges.
- 2) Emission level (dBuV/m)=20log Emission level (uV/m).

3.2.2 TEST PROCEDURE

- a) The measuring distance of at 3 m shall be used for measurements at frequency up to 1GHz. For frequencies above 1GHz, any suitable measuring distance may be used.
- b) The EUT was placed on the top of a rotating table 0.8 meters above the ground at a 3 meter open area test site. The table was rotated 360 degrees to determine the position of the highest radiation.
- c) The height of the equipment or of the substitution antenna shall be 0.8 m; the height of the test antenna shall vary between 0.8 m to 4 m. Both horizontal and vertical polarizations of the antenna are set to make the measurement.
- d) The initial step in collecting conducted emission data is a spectrum analyzer peak detector mode pre-scanning the measurement frequency range. Significant peaks are then marked and then Quasi Peak detector mode re-measured.
- e) If the Peak Mode measured value compliance with and lower than Quasi Peak Mode Limit, the EUT shall be deemed to meet QP Limits and then no additional QP Mode measurement performed.
- f) For the actual test configuration, please refer to the related Item –EUT Test Photos.

Note: Both horizontal and vertical antenna polarities were tested and performed pretest to three orthogonal axis. The worst case emissions were reported

3.2.3 TEST SETUP

a) Radiated Emission Test-Up Frequency 30MHz~1GHz

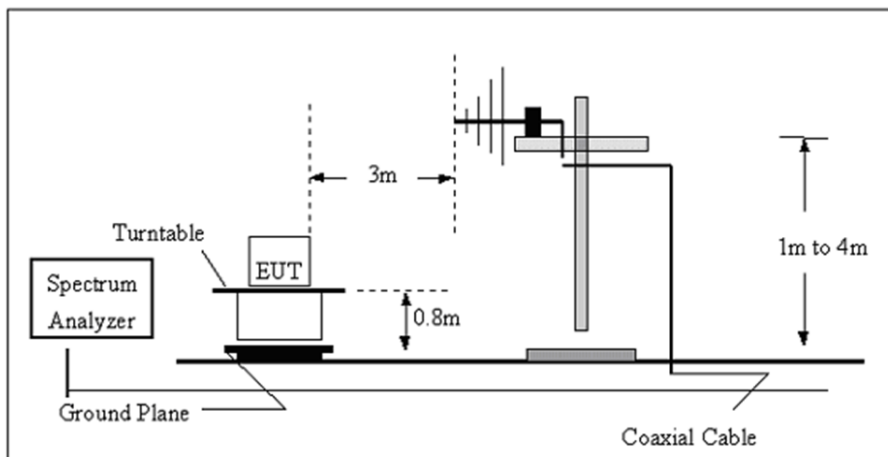

b) Radiated Emission Test-Up Frequency Above 1GHz

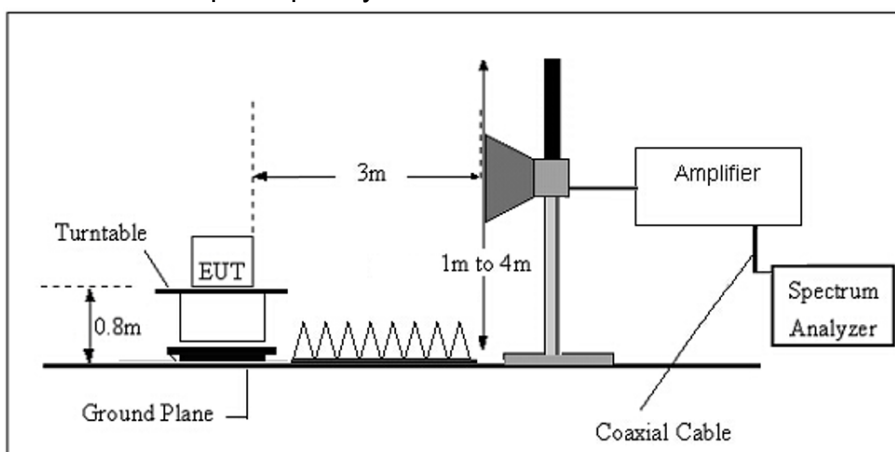

3.2.4 EUT OPERATING CONDITIONS

The EUT tested system was configured as the statements of 2.4 Unless otherwise a special operating condition is specified in the follows during the testing.

3.2.5 TEST RESULTS

Between 30-1000MHz:

Temperature:	25°C	Relative Humidity:	55%
Pressure:	1010hPa	Phase:	Horizontal
Test Voltage:	AC 120V/60Hz	Test Mode:	Mode 5 (Part 15B & ICES-003)
Note:	Adapter(Tenpao)	Test Date:	2019-07-11

No.	Frequency (MHz)	Reading (dBuV)	Factor (dB)	Results (dBuV/m)	Limit (dBuV/m)	Margin (dB)	Detector
1	45.2165	39.58	-19.01	20.57	40.00	-19.43	QP
2	134.5592	48.65	-17.54	31.11	43.50	-12.39	QP
3	172.5988	46.11	-19.36	26.75	43.50	-16.75	QP
4	355.4273	37.14	-13.34	23.80	46.00	-22.20	QP
5	633.9072	37.84	-6.39	31.45	46.00	-14.55	QP
6	952.0937	29.04	-0.36	28.68	46.00	-17.32	QP

Remark:

1. All readings are Quasi-Peak .
2. Margin = Result (Result =Reading + Factor)–Limit

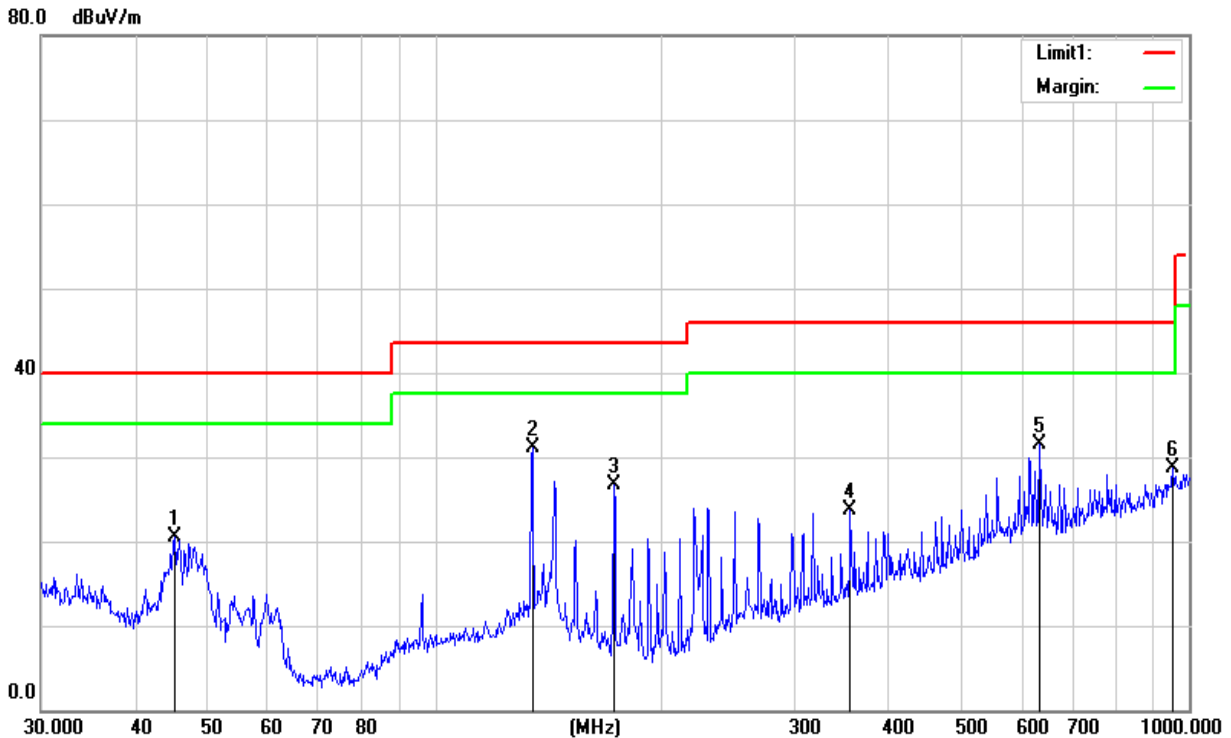

Temperature:	25°C	Relative Humidity:	55%
Pressure:	1010hPa	Phase:	Vertical
Test Voltage:	AC 120V/60Hz	Test Mode:	Mode 5 (Part 15B & ICES-003)
Note:	Adapter(Tenpao)	Test Date:	2019-07-11

No.	Frequency (MHz)	Reading (dBuV)	Factor (dB)	Results (dBuV/m)	Limit (dBuV/m)	Margin (dB)	Detector
1	57.5940	49.33	-23.65	25.68	40.00	-14.32	QP
2	134.5592	51.34	-17.54	33.80	43.50	-9.70	QP
3	172.5988	51.58	-19.36	32.22	43.50	-11.28	QP
4	249.4250	47.44	-16.41	31.03	46.00	-14.97	QP
5	595.1330	41.38	-7.05	34.33	46.00	-11.67	QP
6	912.8620	34.43	-1.82	32.61	46.00	-13.39	QP

Remark:

1. All readings are Quasi-Peak .
2. Margin = Result (Result =Reading + Factor)–Limit

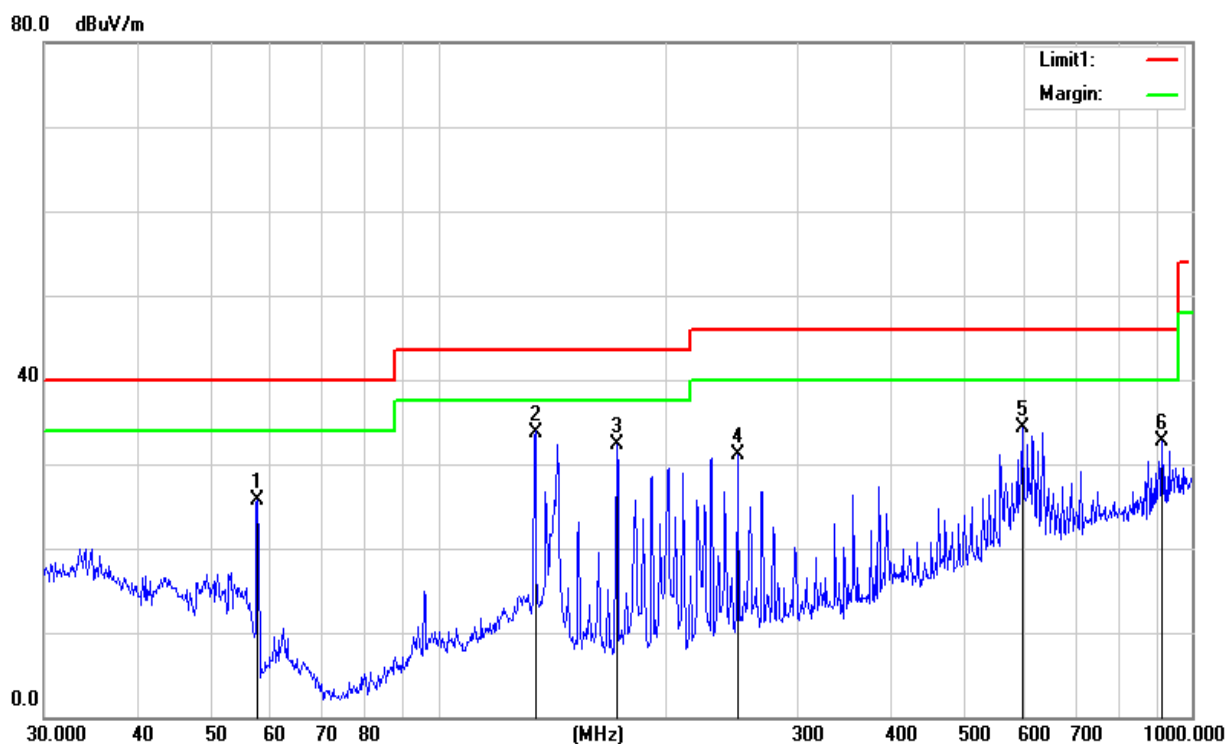

Above 1GHz:

Temperature:	22.4 °C	Relative Humidity:	68%
Pressure:	1010hPa	Phase:	Horizontal
Test Mode:	Mode 5 (Part 15B & ICES-003)	Test Date:	2019-07-11
Note:	Adapter(Tenpao)		

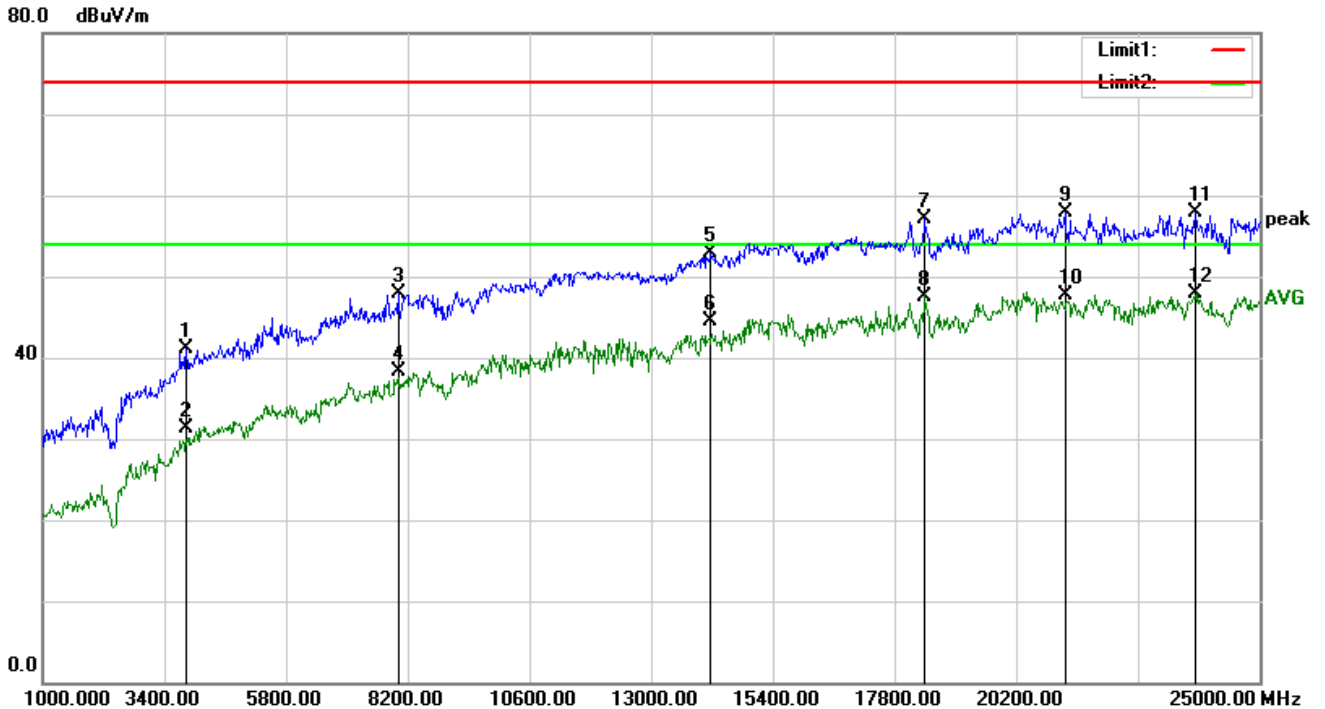

No.	Frequency (MHz)	Reading (dBuV)	Correct Factor(dB/m)	Result (dBuV/m)	Limit (dBuV/m)	Margin (dB)	Remark
1	3832.000	40.17	0.91	41.08	74.00	-32.92	peak
2	3832.000	30.34	0.91	31.25	54.00	-22.75	AVG
3	8008.000	37.19	10.64	47.83	74.00	-26.17	peak
4	8008.000	27.71	10.64	38.35	54.00	-15.65	AVG
5	14176.000	11.54	41.27	52.81	74.00	-21.19	peak
6	14176.000	3.15	41.27	44.42	54.00	-9.58	AVG
7	18400.000	16.52	40.50	57.02	74.00	-16.98	peak
8	18400.000	7.10	40.50	47.60	54.00	-6.40	AVG
9	21160.000	17.40	40.50	57.90	74.00	-16.10	peak
10	21160.000	7.14	40.50	47.64	54.00	-6.36	AVG
11	23728.000	17.43	40.50	57.93	74.00	-16.07	peak
12	23728.000	7.32	40.50	47.82	54.00	-6.18	AVG

Temperature:	22.4 °C	Relative Humidity:	68%
Pressure:	1010hPa	Phase:	Vertical
Test Mode:	Mode 5 (Part 15B & ICES-003)	Test Date:	2019-07-11
Note:	Adapter(Tenpao)		

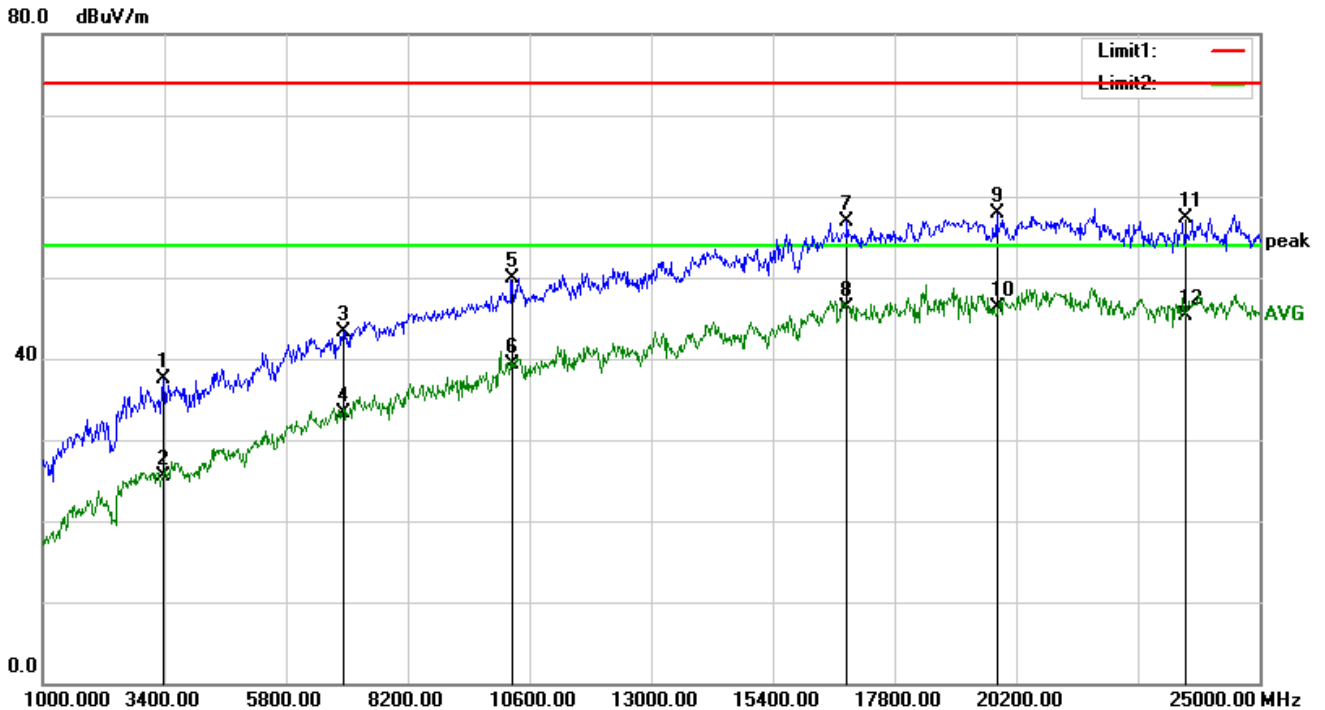

No.	Frequency (MHz)	Reading (dBuV)	Correct Factor(dB/m)	Result (dBuV/m)	Limit (dBuV/m)	Margin (dB)	Remark
1	3376.000	39.01	-1.54	37.47	74.00	-36.53	peak
2	3376.000	27.06	-1.54	25.52	54.00	-28.48	AVG
3	6928.000	33.96	9.30	43.26	74.00	-30.74	peak
4	6928.000	23.94	9.30	33.24	54.00	-20.76	AVG
5	10264.000	35.94	13.97	49.91	74.00	-24.09	peak
6	10264.000	25.25	13.97	39.22	54.00	-14.78	AVG
7	16864.000	17.40	39.43	56.83	74.00	-17.17	peak
8	16864.000	6.90	39.43	46.33	54.00	-7.67	AVG
9	19816.000	17.38	40.50	57.88	74.00	-16.12	peak
10	19816.000	5.85	40.50	46.35	54.00	-7.65	AVG
11	23536.000	16.88	40.50	57.38	74.00	-16.62	peak
12	23536.000	4.80	40.50	45.30	54.00	-8.70	AVG

3.3 RADIATED SPURIOUS EMISSION MEASUREMENT

3.3.1 RADIATED EMISSION LIMITS

in any 100 kHz bandwidth outside the operating frequency band. In case the emission fall within the Restricted band specified on Part15.205(a)&209(a) and RSS-247 Issue 2 limit in the table and according to ANSI C63.10-2013 below has to be followed.

LIMITS OF RADIATED EMISSION MEASUREMENT (0.009MHz - 1000MHz)

Frequencies (MHz)	Field Strength (microvolts/meter)	Measurement Distance (meters)
0.009~0.490	2400/F(KHz)	300
0.490~1.705	24000/F(KHz)	30
1.705~30.0	30	30
30~88	100	3
88~216	150	3
216~960	200	3
Above 960	500	3

LIMITS OF RADIATED EMISSION MEASUREMENT (1000MHz-25GHz)

FREQUENCY (MHz)	(dBuV/m) (at 3M)	
	PEAK	AVERAGE
Above 1000	74	54

Notes:

- (1) The limit for radiated test was performed according to FCC PART 15C.
- (2) The tighter limit applies at the band edges.
- (3) Emission level (dBuV/m)=20log Emission level (uV/m).

For Radiated Emission

Spectrum Parameter	Setting
Attenuation	Auto
Detector	Peak/AV
Start Frequency	1000 MHz(Peak/AV)
Stop Frequency	10th carrier hamonic(Peak/AV)
RB / VB (emission in restricted	1 MHz /3MHz

For Band edge

Spectrum Parameter	Setting
Detector	Peak/AV
Start/Stop Frequency	Lower Band Edge: 2300 to 2422 MHz Upper Band Edge: 2452 to 2500 MHz
RB / VB (emission in restricted band)	1 MHz /3MHz

Receiver Parameter	Setting
Start ~ Stop Frequency	9kHz~90kHz / RB 200Hz for PK & AV
Start ~ Stop Frequency	90kHz~110kHz / RB 200Hz for QP
Start ~ Stop Frequency	110kHz~490kHz / RB 200Hz for PK & AV
Start ~ Stop Frequency	490kHz~30MHz / RB 9kHz for QP
Start ~ Stop Frequency	30MHz~1000MHz / RB 120kHz for QP

3.3.2 TEST PROCEDURE

- a) The measuring distance of at 3 m shall be used for measurements at frequency 0.009MHz up to 1GHz. For frequencies above 1GHz, any suitable measuring distance may be used.
- b) The EUT was placed on the top of a rotating table 0.8 meters(above 1GHz is 1.5 m) above the ground at a 3 meter anechoic chamber. The table was rotated 360 degrees to determine the position of the highest radiation.
- c) The height of the equipment shall be 0.8 m(above 1GHz is 1.5 m); the height of the test antenna shall vary between 1 m to 4 m. Horizontal and vertical polarizations of the antenna are set to make the measurement
- d) The initial step in collecting conducted emission data is a spectrum analyzer peak detector mode pre-scanning the measurement frequency range. Significant peaks are then marked and then Quasi Peak detector mode re-measured.
- e) If the Peak Mode measured value compliance with and lower than Quasi Peak Mode Limit, the EUT shall be deemed to meet QP Limits and then no additional QP Mode measurement performed.
- f) For the actual test configuration, please refer to the related Item –EUT Test Photos.

Note:

Both horizontal and vertical antenna polarities were tested and performed test to three orthogonal axis. The worst case emissions were reported

3.3.3 TEST SETUP

a) Radiated Emission Test-Up Frequency Below 30MHz

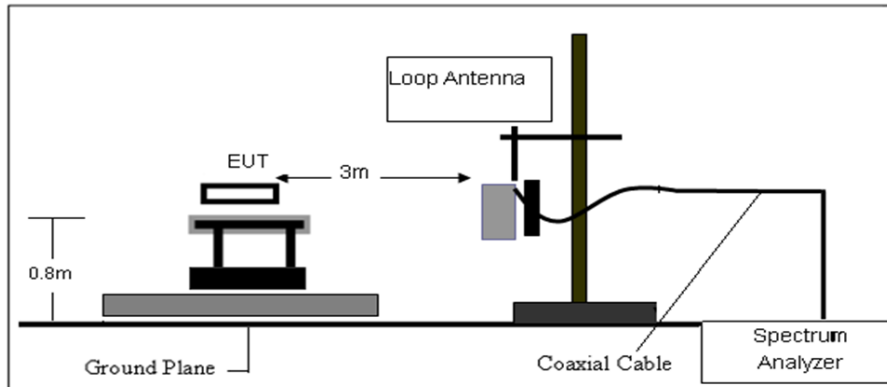

b) Radiated Emission Test-Up Frequency 30MHz~1GHz

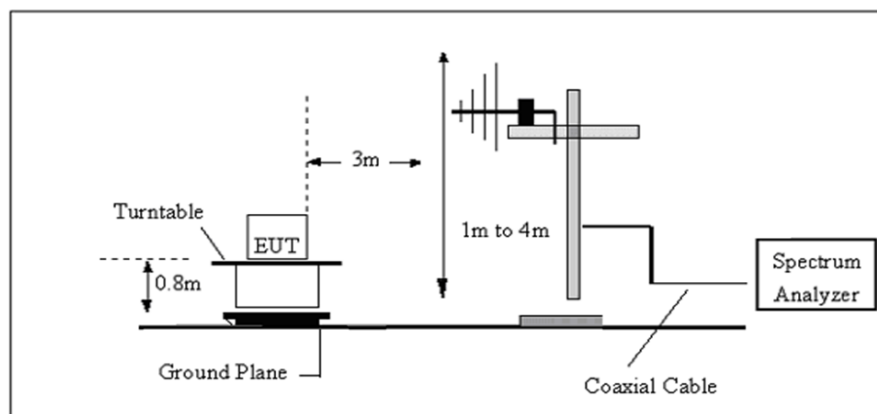

c) Radiated Emission Test-Up Frequency Above 1GHz

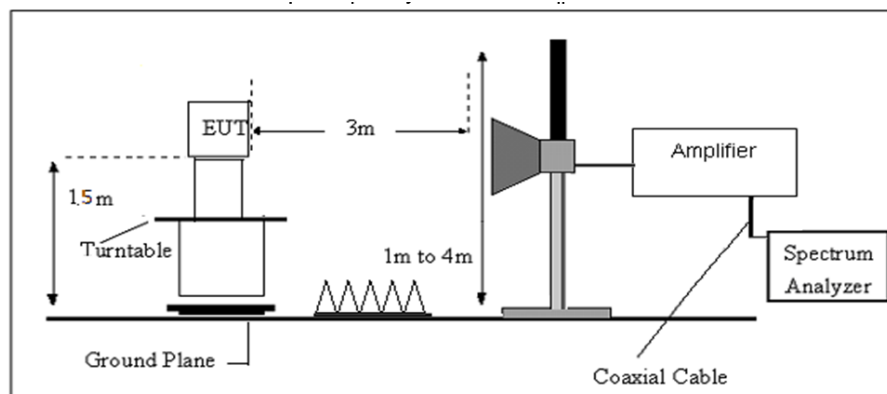

3.3.4 EUT OPERATING CONDITIONS

The EUT tested system was configured as the statements of 2.3 Unless otherwise a special operating condition is specified in the follows during the testing.

3.3.5 FIELD STRENGTH CALCULATION

The field strength is calculated by adding the Antenna Factor and Cable Factor and subtracting the Amplifier Gain and Duty Cycle Correction Factor (if any) from the measured reading. The basic equation with a sample calculation is as follows:

$$FS = RA + AF + CL - AG$$

Where

FS = Field Strength

CL = Cable Attenuation Factor (Cable Loss)

RA = Reading Amplitude

AG = Amplifier Gain

AF = Antenna Factor

For example

Frequency (MHz)	FS (dB μ V/m)	RA (dB μ V/m)	AF (dB)	CL (dB)	AG (dB)	Factor (dB)
300	40	58.1	12.2	1.6	31.9	-18.1

$$\text{Factor} = \text{AF} + \text{CL} - \text{AG}$$

3.3.6 TEST RESULT

9KHz-30MHz

Temperature:	23.2 °C	Relative Humidity:	56%
Test Voltage:	AC 120V/60Hz	Polarization:	--
Test Mode:	TX Mode		

Freq. (MHz)	Reading (dBuV/m)	Limit (dBuV/m)	Margin (dB)	State P/F	Test Result
--	--	--	--	--	PASS
--	--	--	--	--	PASS

Note:

The amplitude of spurious emissions which are attenuated by more than 20dB below the permissible value has no need to be reported.

Distance extrapolation factor = $40 \log (\text{specific distance}/\text{test distance})(\text{dB})$;

Limit line = specific limits(dBuV) + distance extrapolation factor.

(30MHz - 1000MHz)

Temperature:	23.2 °C	Relative Humidity:	56%
Test Voltage:	AC 120V/60Hz	Polarization:	Horizontal
Test Mode:	Mode 1/2/3 (Mode 3 worst mode)	Test Date:	2019-07-11
Note:	Adapter(Tenpao)		

Frequency (MHz)	Reading (dBuV)	Correct Factor(dB/m)	Result (dBuV/m)	Limit (dBuV/m)	Margin (dB)	Remark
41.4215	39.06	-17.06	22.00	40.00	-18.00	QP
117.7724	40.64	-17.83	22.81	43.50	-20.69	QP
209.3130	38.36	-19.78	18.58	43.50	-24.92	QP
359.1860	34.47	-13.17	21.30	46.00	-24.70	QP
494.1983	33.40	-9.05	24.35	46.00	-21.65	QP
774.1584	34.31	-3.25	31.06	46.00	-14.94	QP

Remark:

1. Margin = Result (Result =Reading + Factor)–Limit

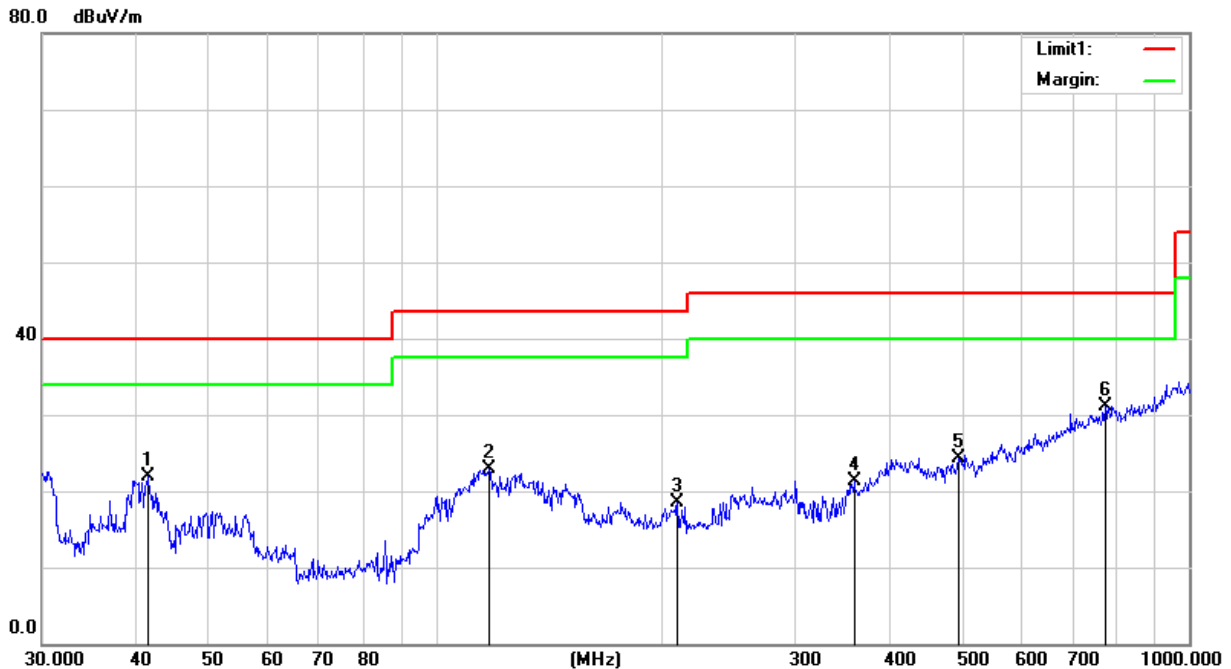

Temperature:	23.2 °C	Relative Humidity:	56%
Test Voltage:	AC 120V/60Hz	Polarization:	Vertical
Test Mode:	Mode 1/2/3 (Mode 3 worst mode)	Test Date:	2019-07-11
Note:	Adapter(Tenpao)		

Frequency (MHz)	Reading (dBuV)	Correct Factor(dB/m)	Result (dBuV/m)	Limit (dBuV/m)	Margin (dB)	Remark
37.8121	43.42	-15.20	28.22	40.00	-11.78	QP
67.6751	38.93	-24.16	14.77	40.00	-25.23	QP
131.7572	40.01	-17.54	22.47	43.50	-21.03	QP
260.1444	36.82	-15.07	21.75	46.00	-24.25	QP
404.6664	35.45	-11.15	24.30	46.00	-21.70	QP
640.6110	37.55	-6.35	31.20	46.00	-14.80	QP

Remark:.

1. Margin = Result (Result =Reading + Factor)–Limit

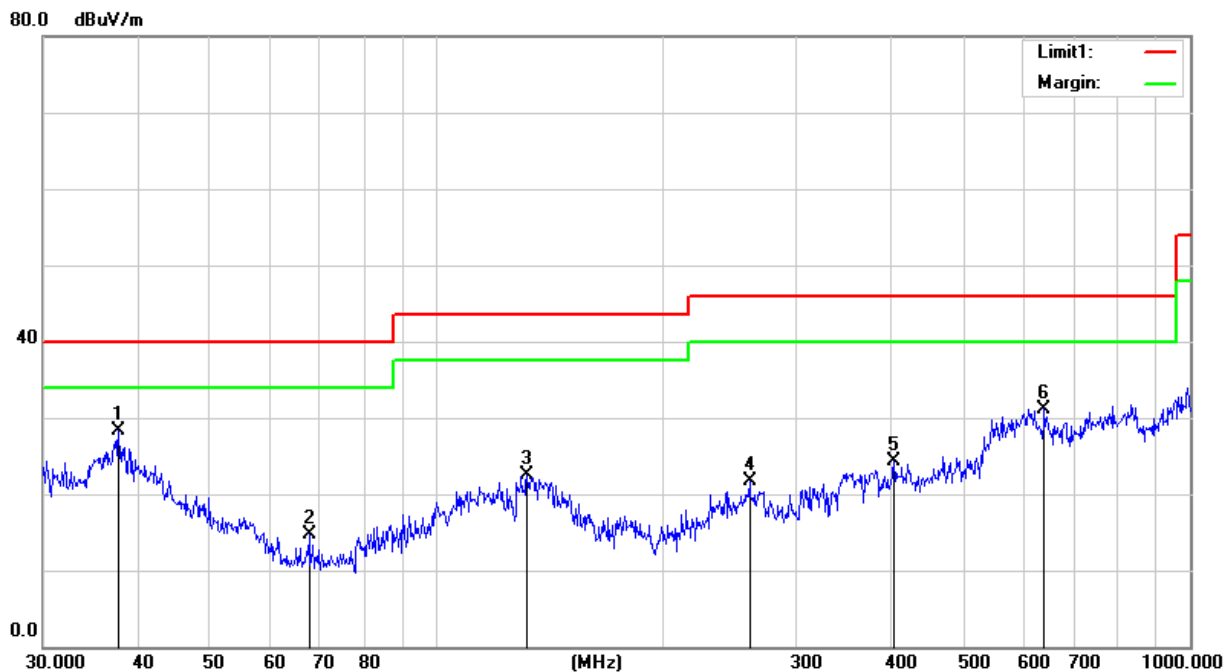

CH Low vertical

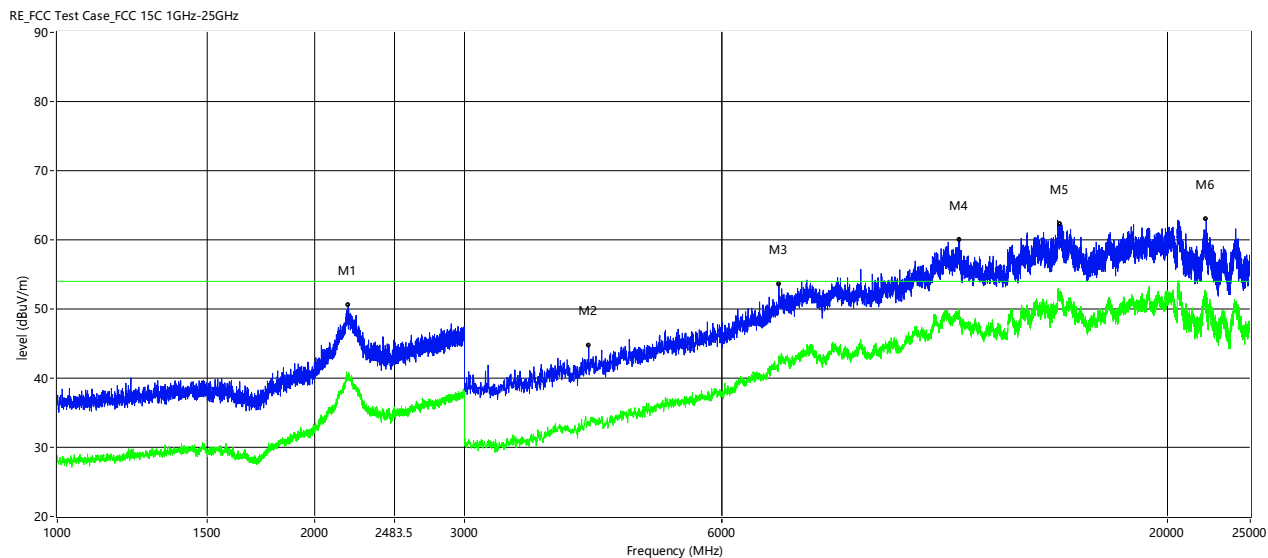

Frequency (MHz)	Peak Level (dBuV/m)	Q-peak Level (dBuV/m)	Average Level (dBuV/m)	Factor (dB)	PK Limit (dBuV/m)	QP Limit (dBuV/m)	AV Limit (dBuV/m)	Over Limit (dB)	ANT	Verdict
2192.000	50.57	--	39.97	10.13	74.0	--	54.0	-14.03	Vertical	Pass
4195.000	44.64	--	33.46	-6.75	74.0	--	54.0	-20.54	Vertical	Pass
7007.500	53.64	--	42.98	2.39	74.0	--	54.0	-11.02	Vertical	Pass
11410.000	60.00	--	48.64	9.72	74.0	--	54.0	-5.36	Vertical	Pass
14961.250	62.22	--	50.57	12.46	74.0	--	54.0	-3.43	Vertical	Pass
22194.749	63.02	--	51.34	9.88	74.0	--	54.0	-2.66	Vertical	Pass

Horizontal

RE_FCC Test Case_FCC 15C 1GHz-25GHz

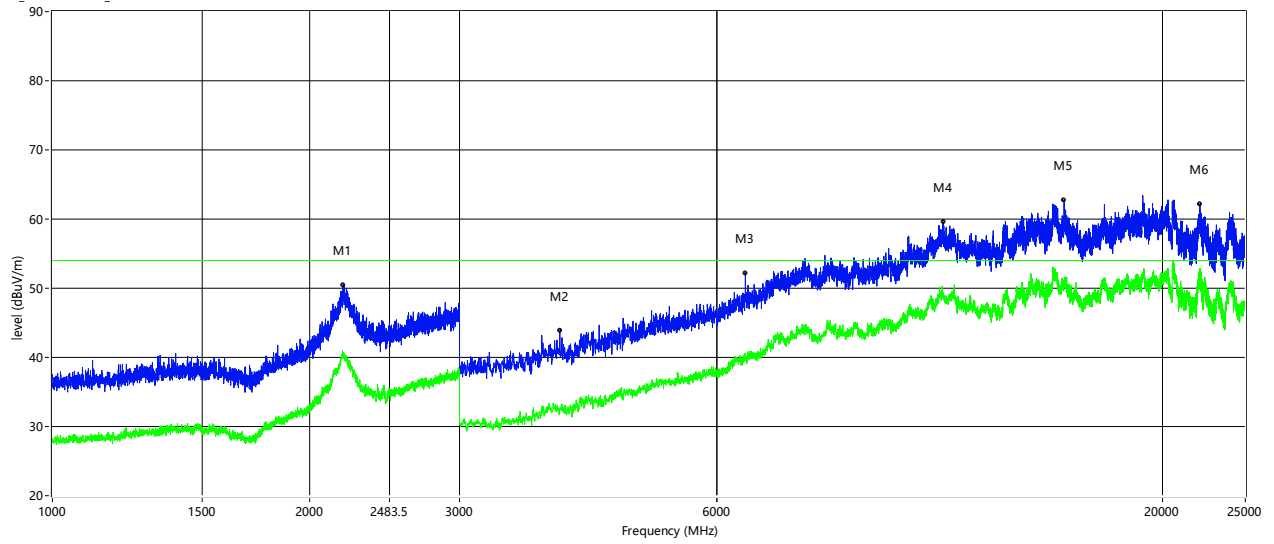

Frequency (MHz)	Peak Level (dBuV/m)	Q-peak Level (dBuV/m)	Average Level (dBuV/m)	Factor (dB)	PK Limit (dBuV/m)	QP Limit (dBuV/m)	AV Limit (dBuV/m)	Over Limit (dB)	ANT	Verdict
2192.500	50.44	--	40.44	10.13	74.0	--	54.0	-13.56	Horizontal	Pass
3932.500	43.84	--	32.65	-8.27	74.0	--	54.0	-21.35	Horizontal	Pass
6487.500	52.16	--	39.86	0.56	74.0	--	54.0	-14.14	Horizontal	Pass
11065.000	59.55	--	49.07	9.97	74.0	--	54.0	-4.93	Horizontal	Pass
15332.500	62.68	--	50.75	11.74	74.0	--	54.0	-3.25	Horizontal	Pass
22119.500	62.12	--	51.37	9.88	74.0	--	54.0	-2.63	Horizontal	Pass

CH Middle

vertical

RE_FCC Test Case_FCC 15C 1GHz-25GHz

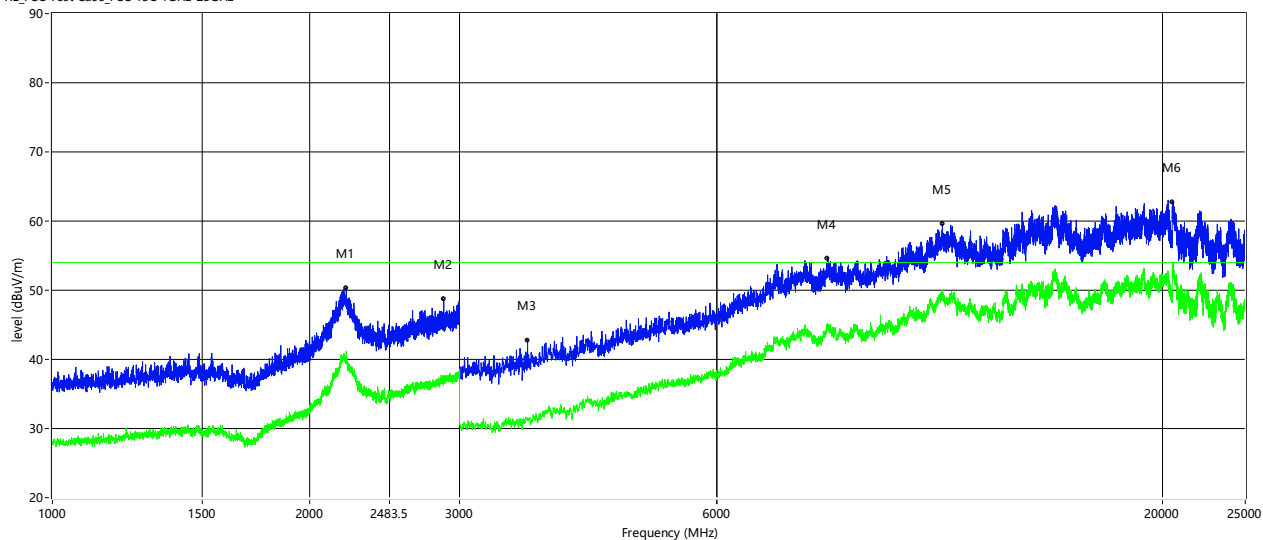

Frequency (MHz)	Peak Level (dBuV/m)	Q-peak Level (dBuV/m)	Average Level (dBuV/m)	Factor (dB)	PK Limit (dBuV/m)	QP Limit (dBuV/m)	AV Limit (dBuV/m)	OverLimit (dB)	ANT	Verdict
2210.000	50.35	--	41.13	9.62	74.0	--	54.0	-12.87	Vertical	Pass
2875.000	48.69	--	36.72	7.11	74.0	--	54.0	-17.28	Vertical	Pass
3605.000	42.77	--	31.55	-9.79	74.0	--	54.0	-22.45	Vertical	Pass
8097.500	54.55	--	45.15	5.13	74.0	--	54.0	-8.85	Vertical	Pass
11040.000	59.54	--	49.53	10.10	74.0	--	54.0	-4.47	Vertical	Pass
20544.500	62.75	--	51.44	14.09	74.0	--	54.0	-2.56	Vertical	Pass

Horizontal

RE_FCC Test Case_FCC 15C 1GHz-25GHz

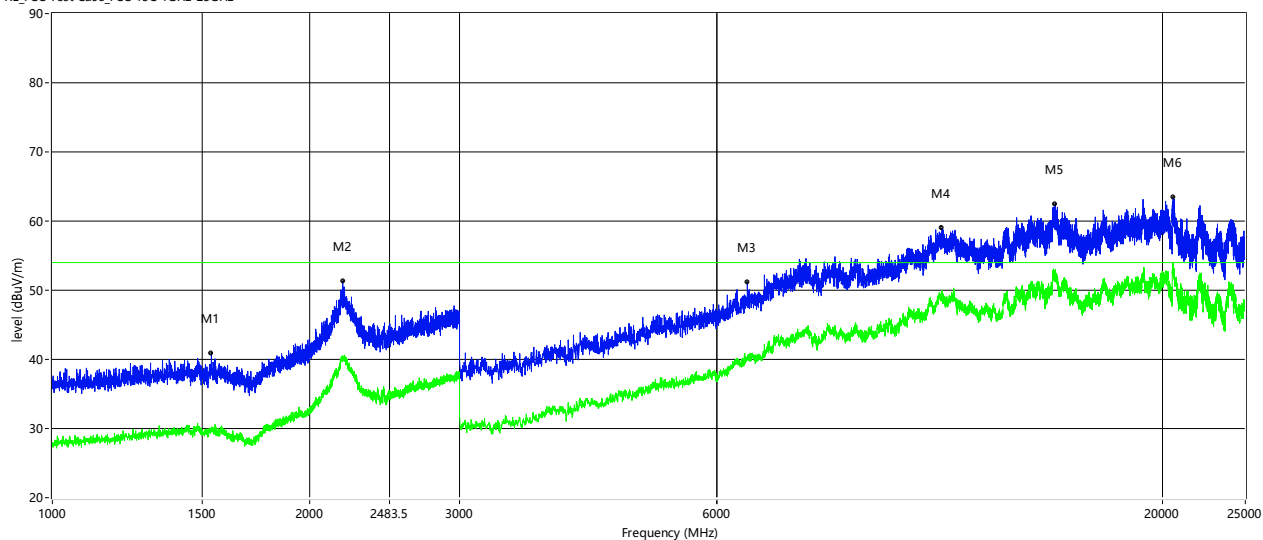

Frequency (MHz)	Peak Level (dBuV/m)	Q-peak Level (dBuV/m)	Average Level (dBuV/m)	Factor (dB)	PK Limit (dBuV/m)	QP Limit (dBuV/m)	AV Limit (dBuV/m)	OverLimit (dB)	ANT	Verdict
1536.000	40.85	--	30.25	0.36	74.0	--	54.0	-23.75	Horizontal	Pass
2189.000	51.25	--	40.48	10.10	74.0	--	54.0	-13.52	Horizontal	Pass
6522.500	51.12	--	40.44	0.70	74.0	--	54.0	-13.56	Horizontal	Pass
11030.000	58.96	--	49.49	10.16	74.0	--	54.0	-4.51	Horizontal	Pass
14967.500	62.45	--	50.90	12.44	74.0	--	54.0	-3.10	Horizontal	Pass
20574.251	63.38	--	51.39	14.13	74.0	--	54.0	-2.61	Horizontal	Pass

CH High vertical

RE_FCC Test Case_FCC 15C 1GHz-25GHz

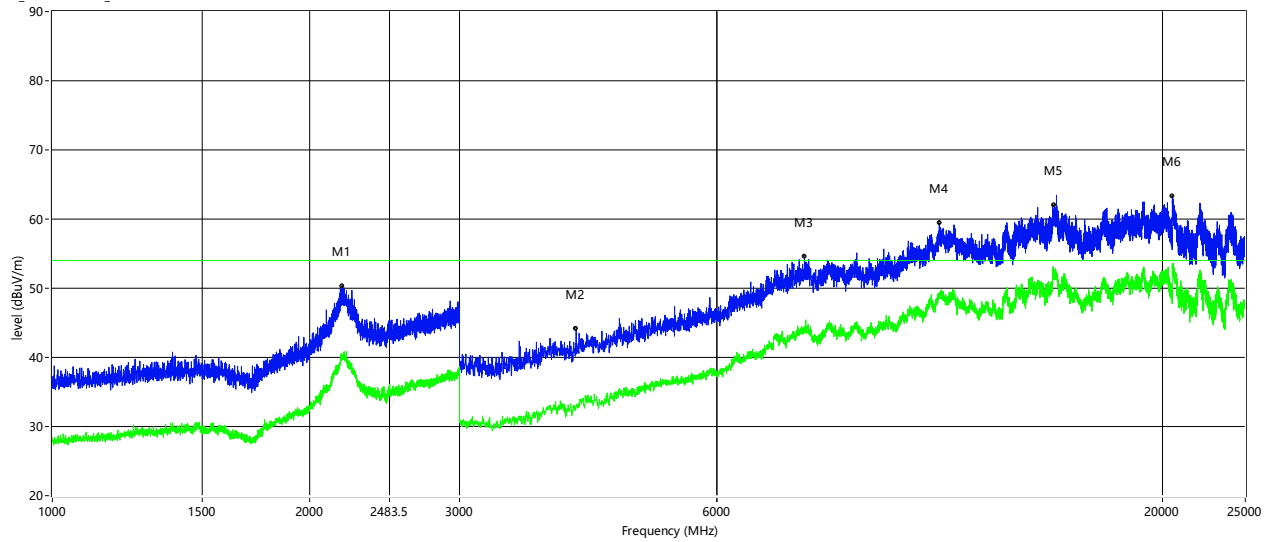

Frequency (MHz)	Peak Level (dBuV/m)	Q-peak Level (dBuV/m)	Average Level (dBuV/m)	Factor (dB)	PK Limit (dBuV/m)	QP Limit (dBuV/m)	AV Limit (dBuV/m)	Over Limit (dB)	ANT	Verdict
2188.500	50.31	--	39.90	10.10	74.0	--	54.0	-14.10	Vertical	Pass
4110.000	44.07	--	33.11	-7.52	74.0	--	54.0	-20.89	Vertical	Pass
7610.000	54.51	--	44.53	4.29	74.0	--	54.0	-9.47	Vertical	Pass
10947.500	59.42	--	49.41	10.01	74.0	--	54.0	-4.59	Vertical	Pass
14932.500	62.05	--	51.04	12.54	74.0	--	54.0	-2.96	Vertical	Pass
20537.500	63.28	--	51.47	14.08	74.0	--	54.0	-2.53	Vertical	Pass

Horizontal

RE_FCC Test Case_FCC 15C 1GHz-25GHz

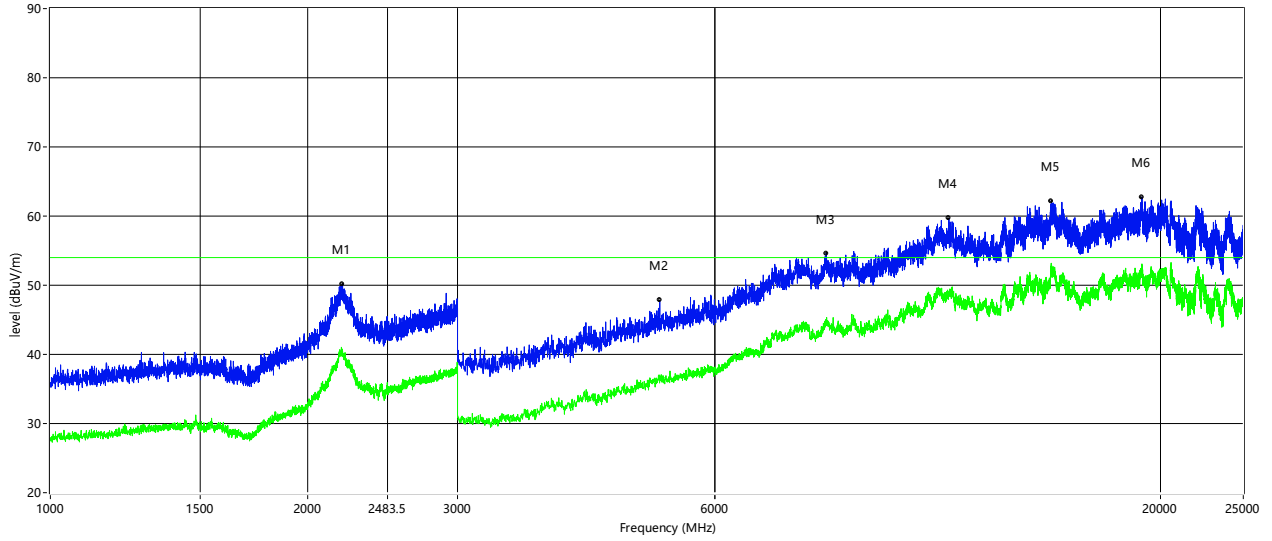

Frequency (MHz)	Peak Level (dBuV/m)	Q-peak Level (dBuV/m)	Average Level (dBuV/m)	Factor (dB)	PK Limit (dBuV/m)	QP Limit (dBuV/m)	AV Limit (dBuV/m)	Over Limit (dB)	ANT	Verdict
2200.000	50.21	--	40.53	10.19	74.0	--	54.0	-13.47	Horizontal	Pass
5177.500	47.82	--	36.72	-3.53	74.0	--	54.0	-17.28	Horizontal	Pass
8112.500	54.64	--	45.02	5.01	74.0	--	54.0	-8.98	Horizontal	Pass
11297.500	59.67	--	48.34	9.59	74.0	--	54.0	-5.66	Horizontal	Pass
14892.500	62.19	--	51.10	12.53	74.0	--	54.0	-2.90	Horizontal	Pass
19020.249	62.75	--	51.33	15.22	74.0	--	54.0	-2.67	Horizontal	Pass

3.3.7 TEST RESULTS (RESTRICTED BAND)

CH Low Horizontal

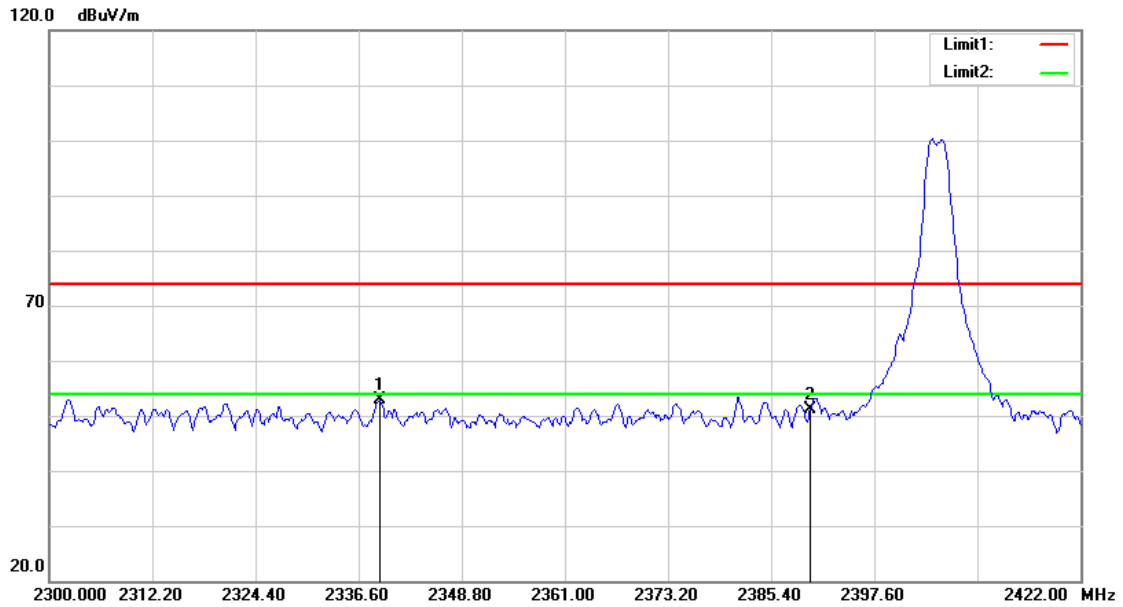

No.	Frequency (MHz)	Reading (dBuV)	Correct Factor(dB/m)	Result (dBuV/m)	Limit (dBuV/m)	Margin (dB)	Remark
1	2339.040	25.74	27.05	52.79	74.00	-21.21	peak
2	2390.000	23.98	27.23	51.21	74.00	-22.79	peak

Vertical

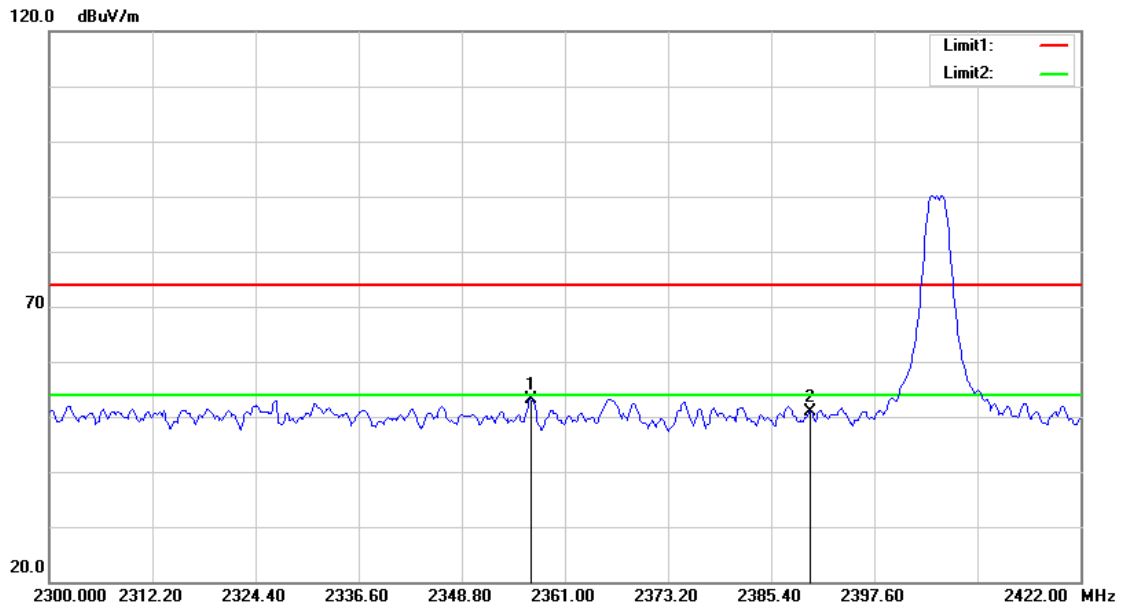

No.	Frequency (MHz)	Reading (dBuV)	Correct Factor(dB/m)	Result (dBuV/m)	Limit (dBuV/m)	Margin (dB)	Remark
1	2356.974	26.14	27.11	53.25	74.00	-20.75	peak
2	2390.000	23.69	27.23	50.92	74.00	-23.08	peak

CH High Horizontal

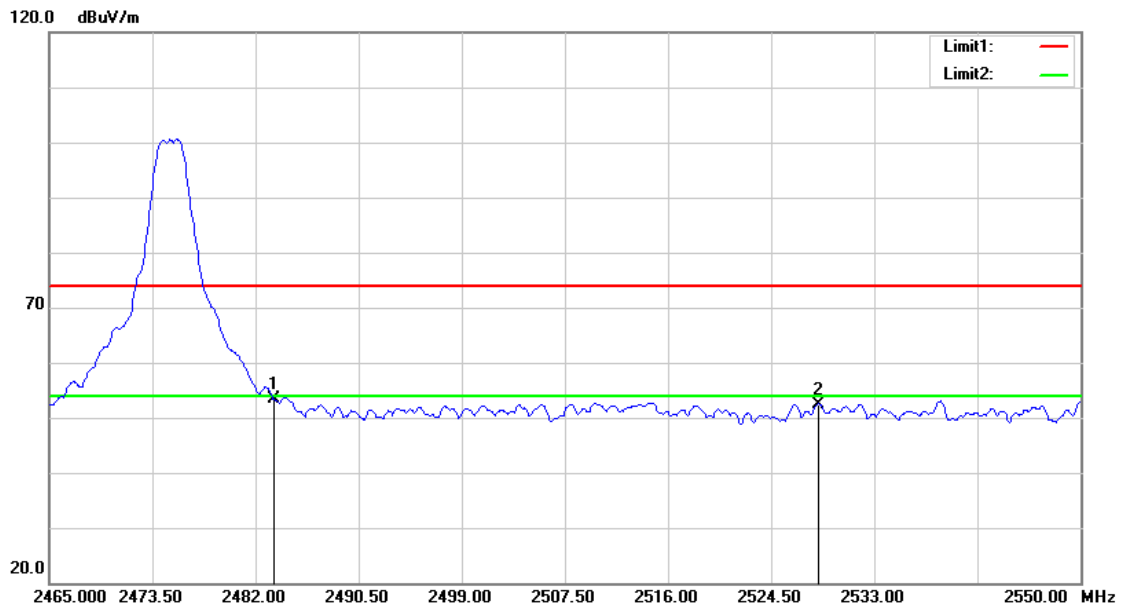

No.	Frequency (MHz)	Reading (dBuV)	Correct Factor(dB/m)	Result (dBuV/m)	Limit (dBuV/m)	Margin (dB)	Remark
1	2483.500	25.73	27.54	53.27	74.00	-20.73	peak
2	2528.410	24.87	27.63	52.50	74.00	-21.50	peak

Vertical

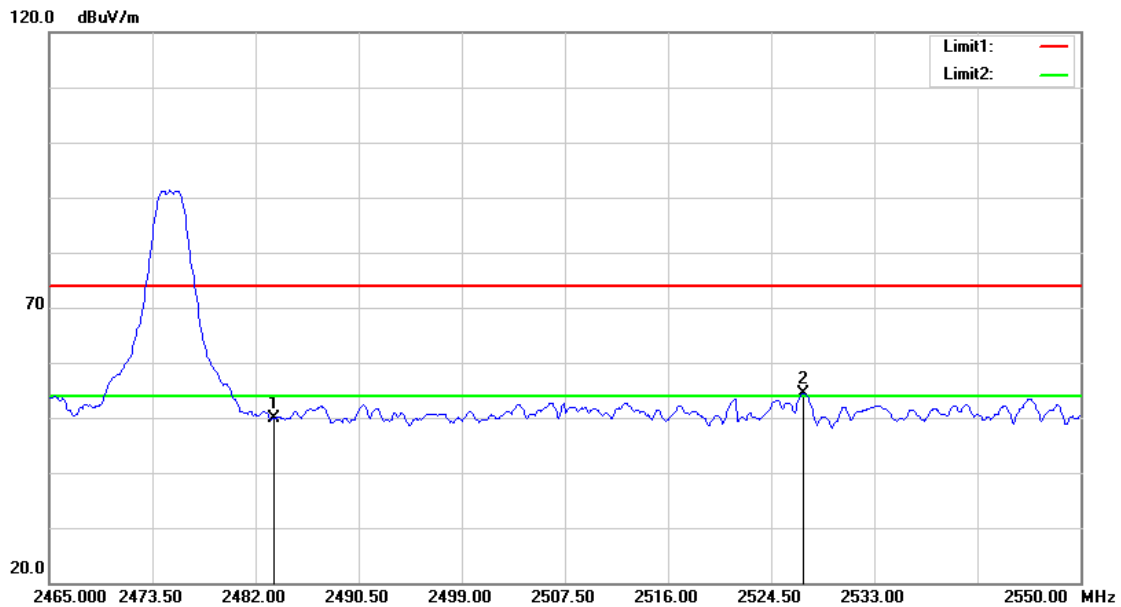

No.	Frequency (MHz)	Reading (dBuV)	Correct Factor(dB/m)	Result (dBuV/m)	Limit (dBuV/m)	Margin (dB)	Remark
1	2483.500	22.24	27.54	49.78	74.00	-24.22	peak
2	2527.135	26.81	27.63	54.44	74.00	-19.56	peak

4 CONDUCTED SPURIOUS & BAND EDGE EMISSION

4.1 APPLIED PROCEDURES / LIMIT

According to FCC Part 15.247(d) and RSS-247 Clause 5.5, in any 100kHz bandwidth outside the frequency band in which the spread spectrum or digitally modulated intentional radiator is operating, the radio frequency power that is produced by the intentional radiator shall be at least 20dB below that in the 100kHz bandwidth within the band that contains the highest level of the desired power, based on either an RF conducted or a radiated measurement.

4.2 TEST PROCEDURE

Spectrum Parameter	Setting
Detector	Peak
Start/Stop Frequency	30 MHz to 10th carrier harmonic
RB / VB (emission in restricted band)	100 KHz/300 KHz
Trace-Mode:	Max hold

For Band edge

Spectrum Parameter	Setting
Detector	Peak
Start/Stop Frequency	Lower Band Edge: 2300 to 2422 MHz Upper Band Edge: 2452 to 2500 MHz
RB / VB (emission in restricted band)	100 KHz/300 KHz
Trace-Mode:	Max hold

4.3 DEVIATION FROM STANDARD

No deviation.

4.4 TEST SETUP

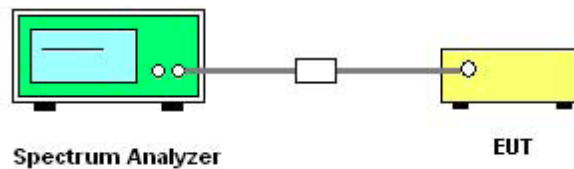

The EUT which is powered by the Adapter, is coupled to the Spectrum Analyzer; the RF load attached to the EUT antenna terminal is 50Ohm; the path loss as the factor is calibrated to correct the reading.

Make the measurement with the spectrum analyzer's resolution bandwidth (RBW) = 100 kHz. In order to make an accurate measurement, set the span greater than RBW.

4.5 EUT OPERATION CONDITIONS

The EUT tested system was configured as the statements of 2.3 Unless otherwise a special operating condition is specified in the follows during the testing.

4.6 TEST RESULTS

Temperature :	25 °C	Relative Humidity :	60%
Test Voltage :	AC 120V/60Hz	Test Mode :	TX Mode

CH Low

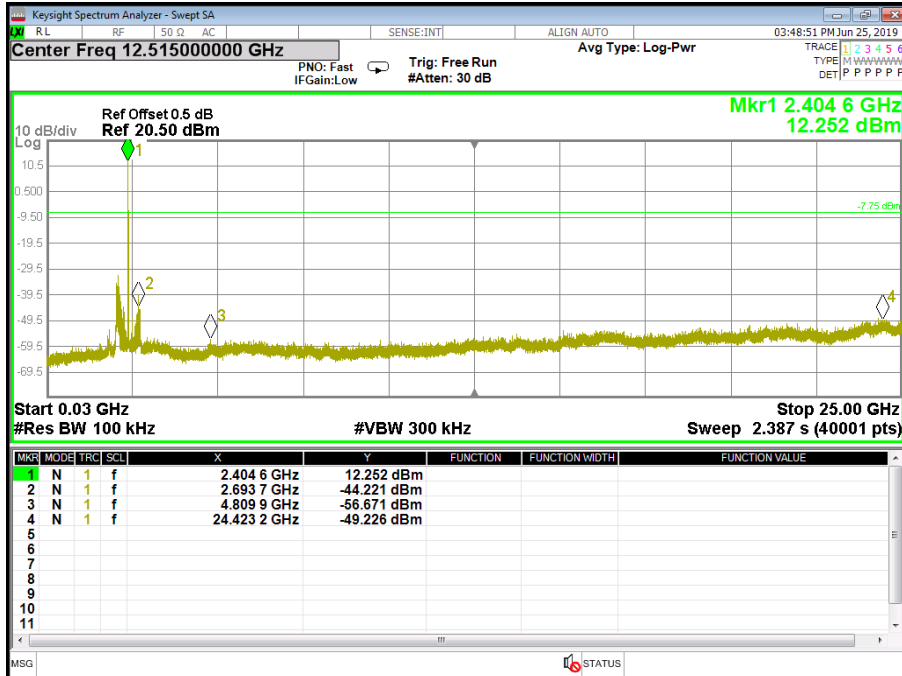

CH Middle

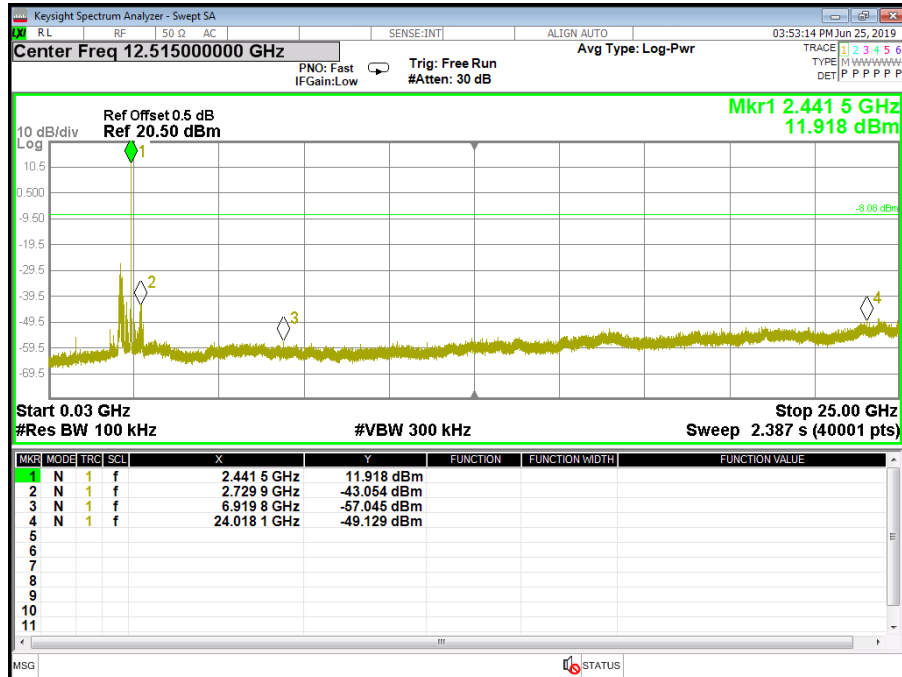

CH High

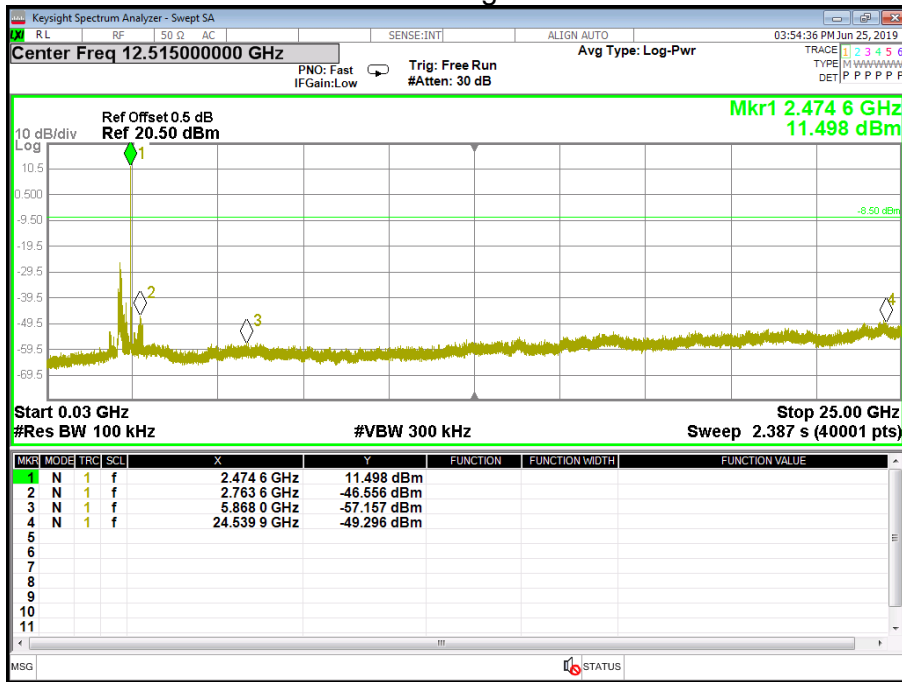

CH Low

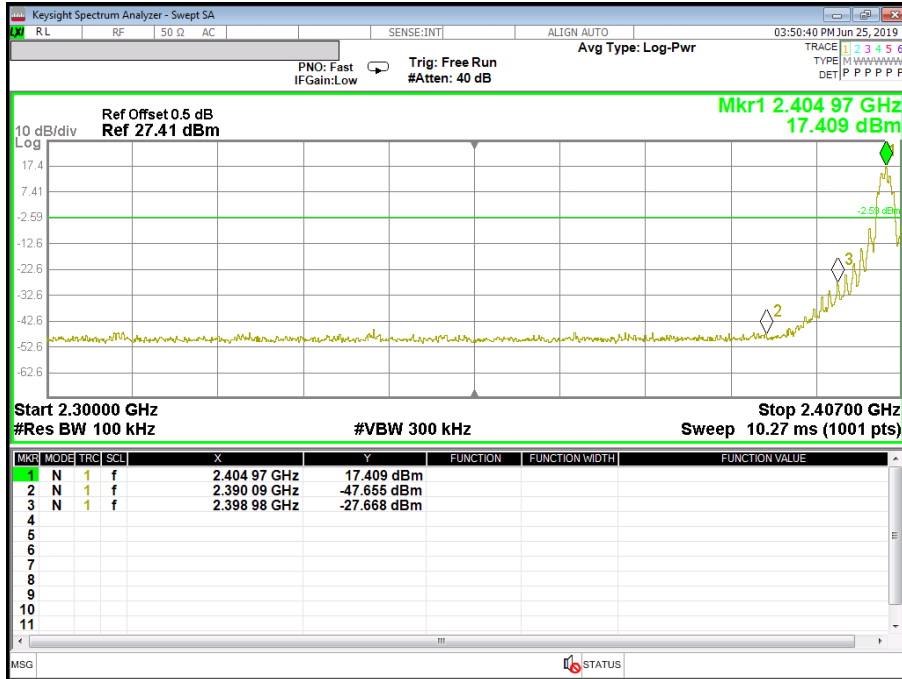

CH High

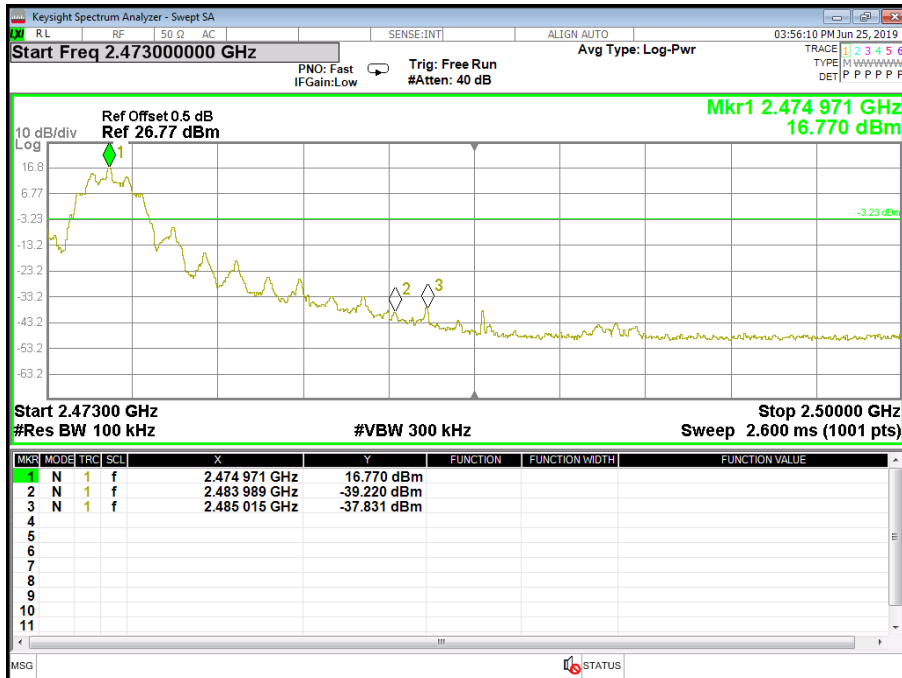

CH Low

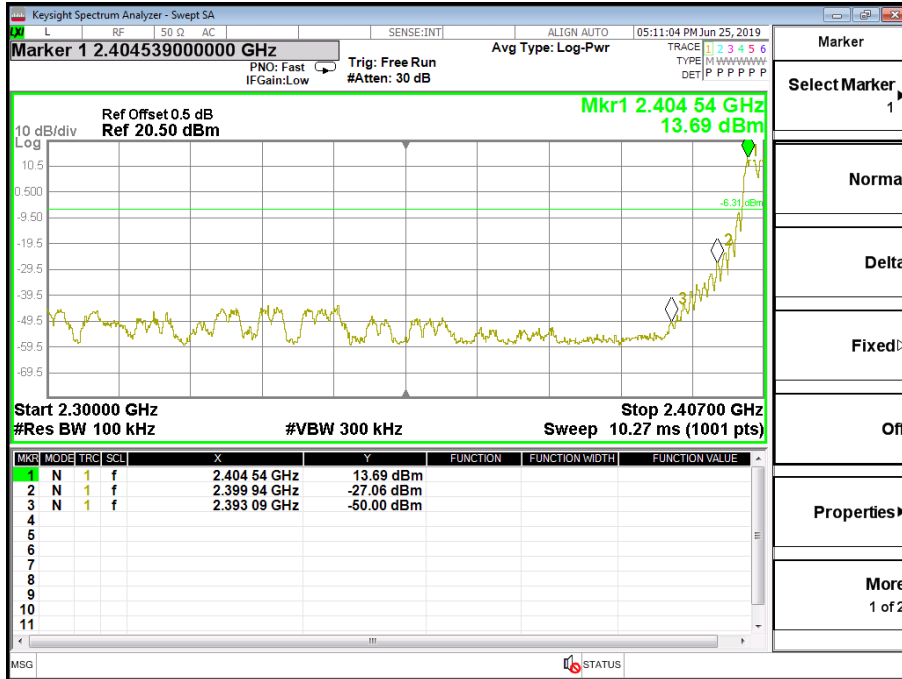

CH High

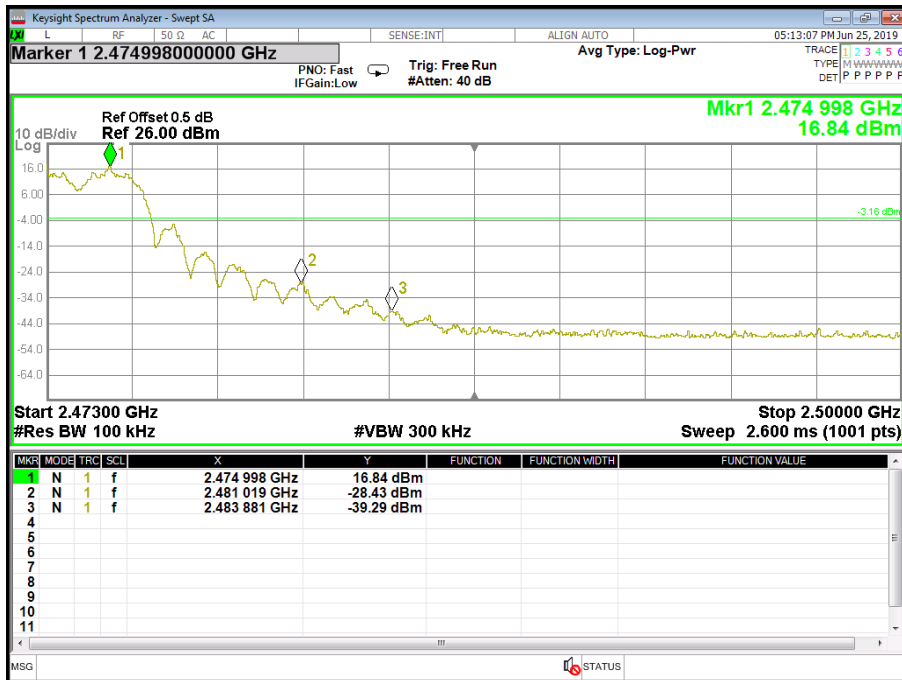

5 NUMBER OF HOPPING CHANNEL

5.1 APPLIED PROCEDURES / LIMIT

FCC Part 15.247, Subpart C RSS-247 Issue 2				
Section	Test Item	Limit	Frequency Range (MHz)	Result
FCC Part 15.247(a)(1) RSS-247 Clause 5.1(d)	Number of Hopping Channel	≥15	2400-2483.5	PASS

Spectrum Parameters	Setting
Attenuation	Auto
Span Frequency	> Operating FrequencyRange
RB	1MHz
VB	1MHz
Detector	Peak
Trace	Max Hold
Sweep Time	Auto

5.2 TEST PROCEDURE

- 1) The EUT was directly connected to the spectrum analyzer and antenna output port as show in the block diagram below
- 2) Spectrum Setting : RBW= 1MHz, VBW=1MHz, Sweep time = Auto.

5.3 DEVIATION FROM STANDARD

No deviation.

5.4 TEST SETUP



5.5 EUT OPERATION CONDITIONS

The EUT tested system was configured as the statements of 2.3 Unless otherwise a special operating condition is specified in the follows during the testing.

5.6 TEST RESULTS

Temperature:	25 °C	Relative Humidity:	60%
Test Voltage:	AC 120V/60Hz	Test Mode:	Hopping mode

Number of Hopping Channel

16

Hopping channel

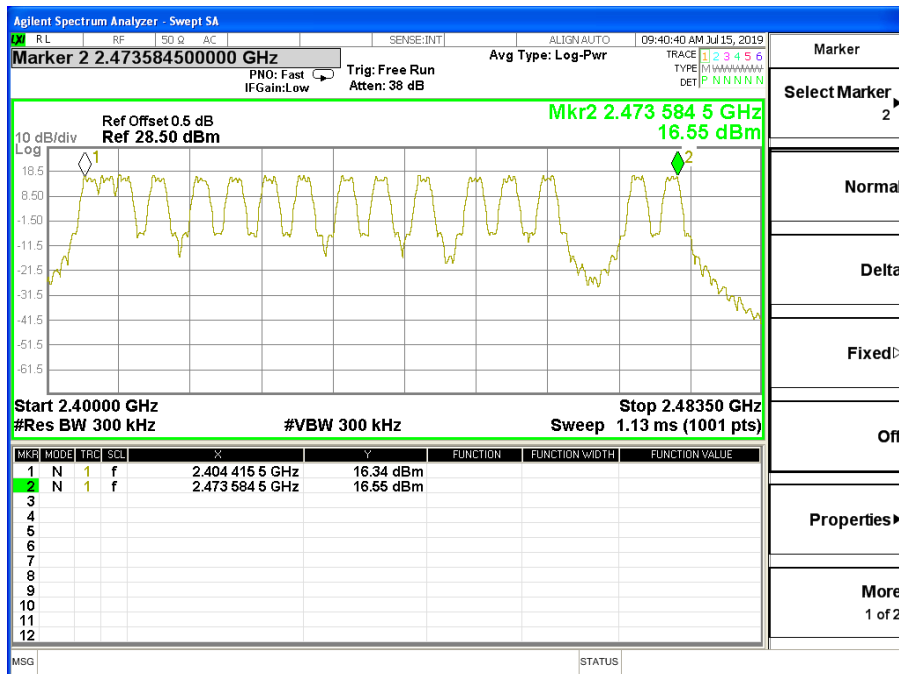

6 AVERAGE TIME OF OCCUPANCY

6.1 APPLIED PROCEDURES / LIMIT

FCC Part 15.247, Subpart C RSS-247 Issue 2				
Section	Test Item	Limit	Frequency Range (MHz)	Result
FCC Part 15.247(a)(1) RSS-247 Clause 5.1(d)	Average Time of Occupancy	0.4sec	2400-2483.5	PASS

6.2 TEST PROCEDURE

- 1) The transmitter output (antenna port) was connected to the spectrum analyzer
- 2) Set RBW =1MHz/VBW =3MHz.
- 3) Use a video trigger with the trigger level set to enable triggering only on full pulses.
- 4) Sweep Time is more than once pulse time.
- 5) Set the center frequency on any frequency would be measure and set the frequency span to zero span.
- 6) Measure the maximum time duration of one single pulse.
- 7) Measure the maximum burst number of one hopping period.
- 8) A Period Time = $16 \times 0.4 = 6.4$ S

6.3 DEVIATION FROM STANDARD

No deviation.

6.4 TEST SETUP

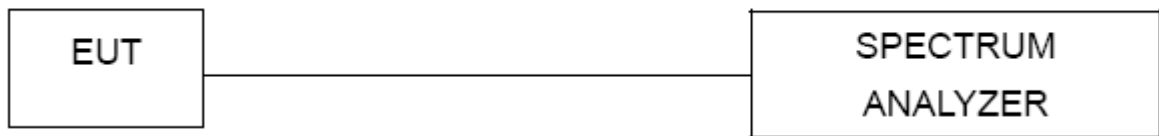

6.5 EUT OPERATION CONDITIONS

The EUT tested system was configured as the statements of 2.3 Unless otherwise a special operating condition is specified in the follows during the testing.

6.6 TEST RESULTS

Temperature:	25 °C	Relative Humidity:	60%
Test Voltage:	AC 120V/60Hz	Test Mode:	Hopping mode

Frequency (MHz)	Pulse Duration(ms)	Pulse number	Dwell Time(s)	Limits(s)
CH Low	7.76	40.00	0.3103	0.4
CH Middle	7.76	40.00	0.3103	0.4
CH High	7.76	40.00	0.3103	0.4

CH Low Dwell Time

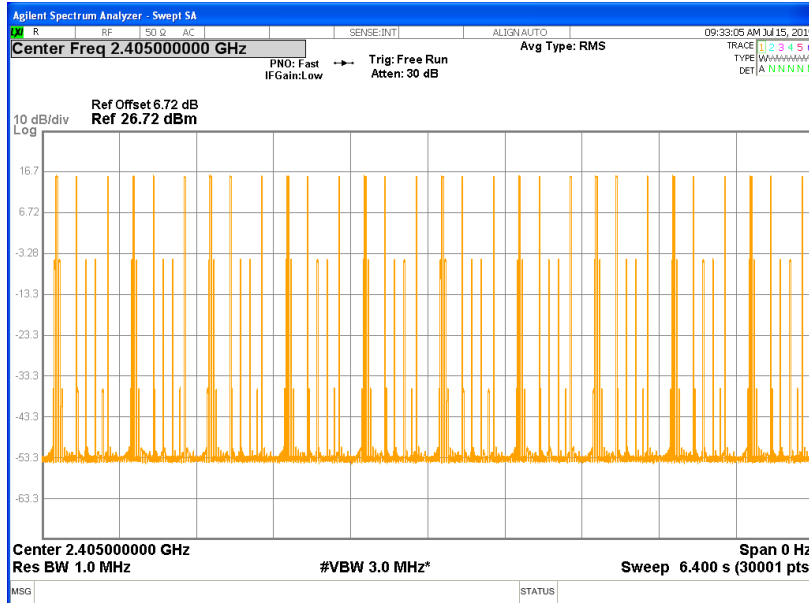

One Pulse

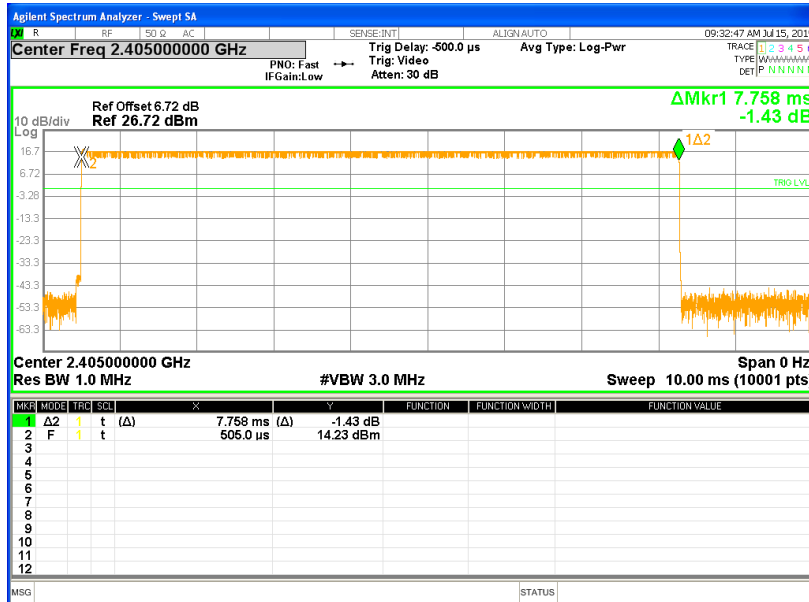

CH Middle Dwell Time

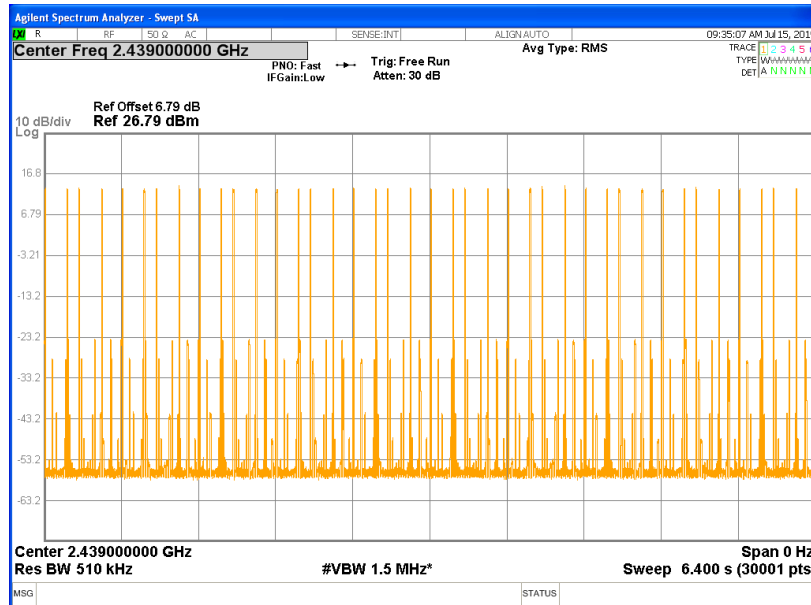

One Pulse

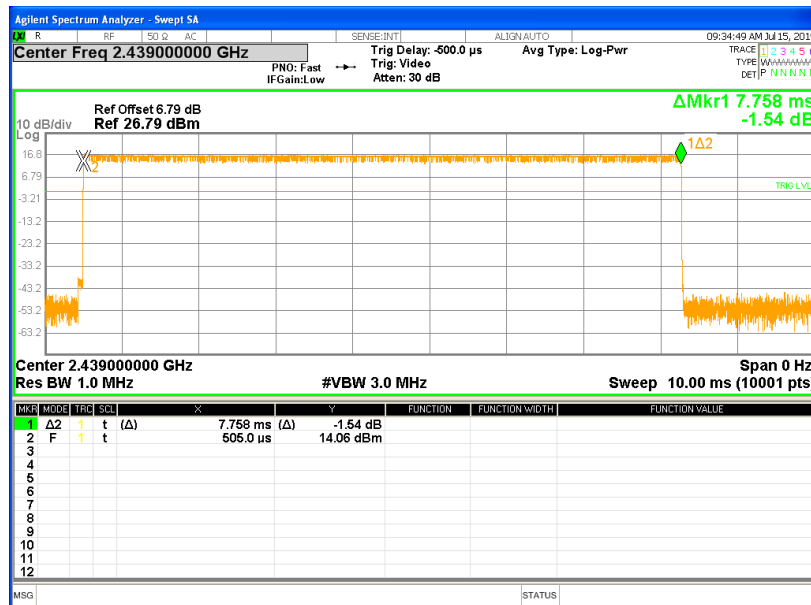

CH High Dwell Time

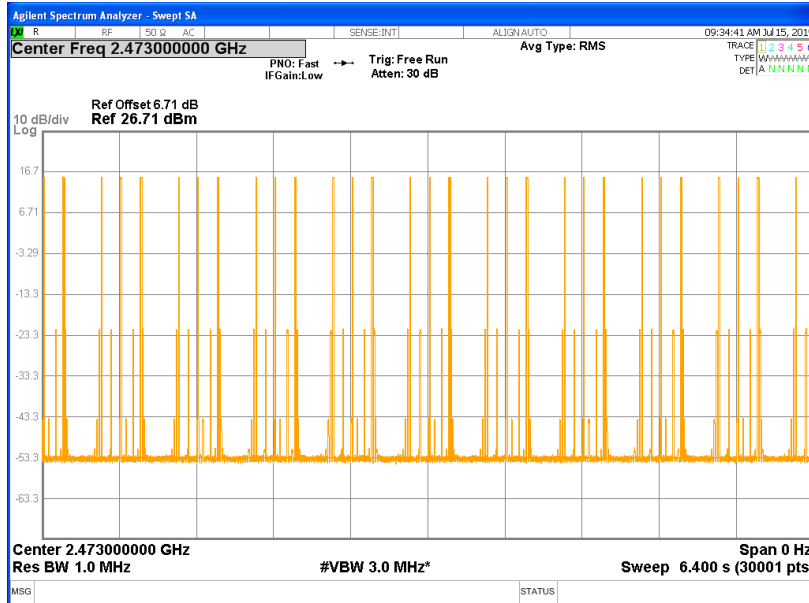

One Pulse

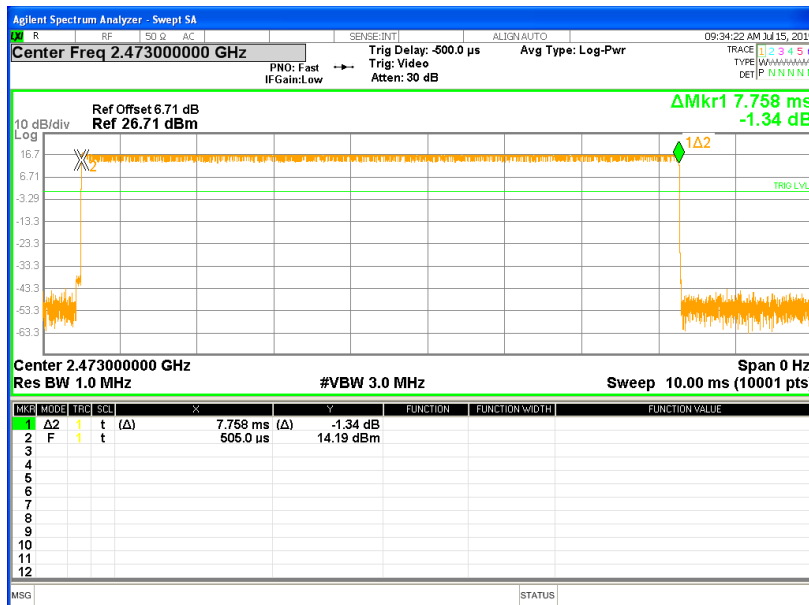

7 HOPPING CHANNEL SEPARATION MEASUREMENT

7.1 APPLIED PROCEDURES / LIMIT

Frequency hopping systems shall have hopping channel carrier frequencies separated by a minimum of 25 kHz or the 20 dB bandwidth of the hopping channel, whichever is greater. Alternatively, frequency hopping systems operating in the 2400-2483.5 MHz band may have hopping channel carrier frequencies that are separated by 25 kHz or two-thirds of the 20 dB bandwidth of the hopping channel, whichever is greater, provided the systems operate with an output power no greater than 125 mW.

Spectrum Parameter	Setting
Attenuation	Auto
Span Frequency	> 20 dB Bandwidth or Channel Separation
RB	30 kHz (20dB Bandwidth) / 30 kHz (Channel Separation)
VB	100 kHz (20dB Bandwidth) / 100 kHz (Channel Separation)
Detector	Peak
Trace	Max Hold
Sweep Time	Auto

7.2 TEST PROCEDURE

- 1) The transmitter output (antenna port) was connected to the spectrum analyser in peak hold mode.
- 2) The resolution bandwidth of 30 kHz and the video bandwidth of 100 kHz were utilised for 20 dB bandwidth measurement.
- 3) The resolution bandwidth of 30 kHz and the video bandwidth of 100 kHz were utilised for channel separation measurement.

7.3 DEVIATION FROM STANDARD

No deviation.

7.4 TEST SETUP

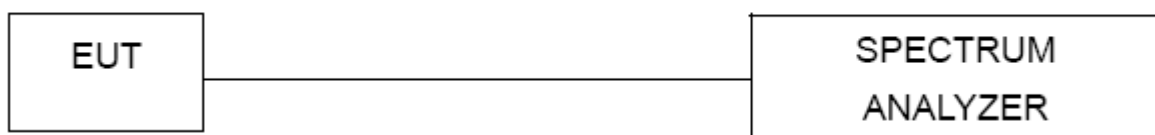

7.5 EUT OPERATION CONDITIONS

The EUT was programmed to be in continuously transmitting mode.

7.6 TEST RESULTS

Temperature:	25 °C	Relative Humidity:	60%
Test Voltage:	AC 120V/60Hz	Test Mode:	Hopping mode

Test Mode	Frequency	Ch. Separation (MHz)	Limit	Result
TX	CH Low	2.000	1.456	Complies
	CH Middle	4.970	1.410	Complies
	CH High	2.024	1.415	Complies

Ch. Separation Limits: > two-thirds 20dB bandwidth

CH Low

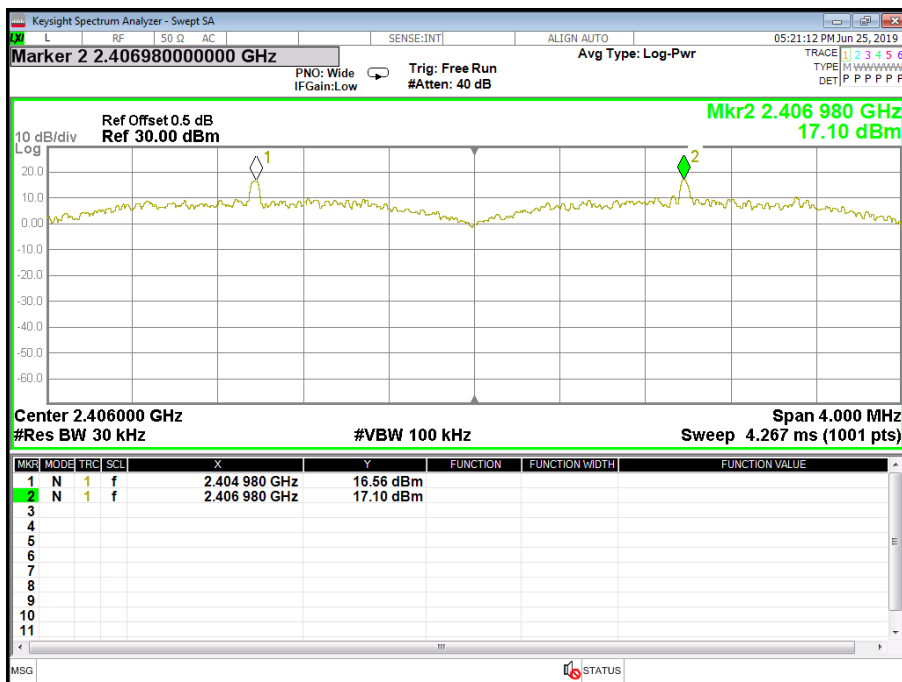

CH Middle

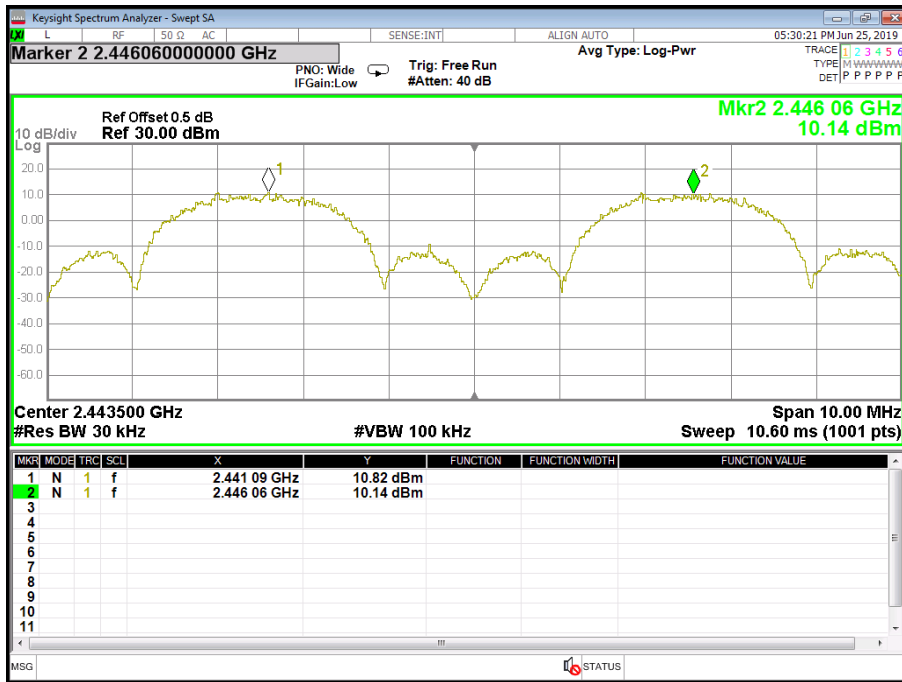

CH High

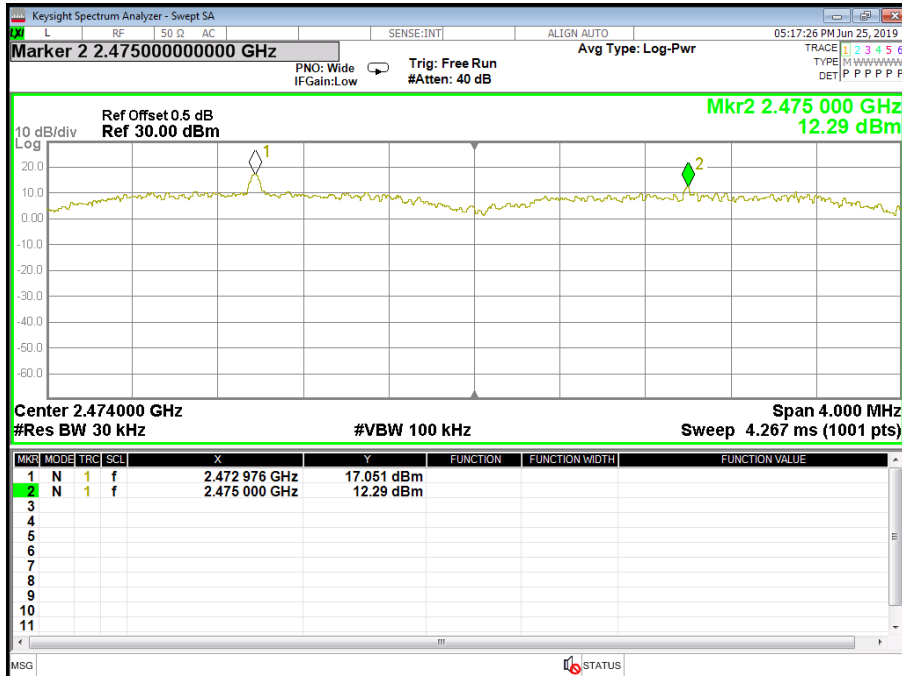

8 BANDWIDTH TEST

8.1 APPLIED PROCEDURES / LIMIT

FCC Part 15.247, Subpart C RSS-247 Issue 2 & RSS-Gen Issue 5				
Section	Test Item	Limit	Frequency Range (MHz)	Result
FCC Part 15.247(a)(1) RSS-247 Clause 5.1(a)	Bandwidth	(20dB Bandwidth)	2400-2483.5	PASS
RSS-Gen Clause 6.7	99% Bandwidth	-	2400-2483.5	PASS

8.2 TEST PROCEDURE

The automatic bandwidth measurement capability of an instrument may be employed using the X dB bandwidth mode with X set to 6 dB, if the functionality described above (i.e., RBW = 1% - 5% OBW, VBW ≥ 3RBW, peak detector with maximum hold) is implemented by the instrumentation function. When using this capability, care shall be taken so that the bandwidth measurement is not influenced by any intermediate power nulls in the fundamental emission that might be ≥ 6 dB.

8.3 DEVIATION FROM STANDARD

No deviation.

8.4 TEST SETUP



8.5 EUT OPERATION CONDITIONS

The EUT tested system was configured as the statements of 2.3 Unless otherwise a special operating condition is specified in the follows during the testing.

8.6 TEST RESULTS

Temperature:	25 °C	Relative Humidity:	60%
Test Voltage:	AC 120V/60Hz	Test Mode:	TX Mode

Remark: PEAK DETECTOR IS USED

Test Mode	Frequency (MHz)	20dB Bandwidth (MHz)	99% Bandwidth (MHz)	Limit of 20dB Bandwidth (MHz)	Result
TX	CH Low	2.184	2.1575	N/A	PASS
	CH Middle	2.195	2.1488	N/A	PASS
	CH High	2.123	2.1608	N/A	PASS

CH Low

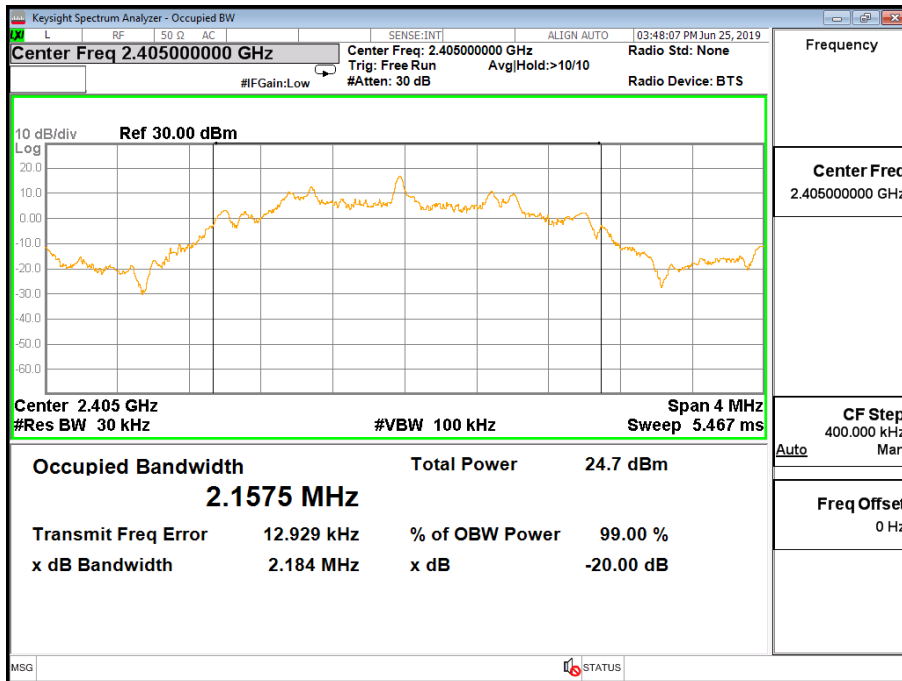

CH Middle

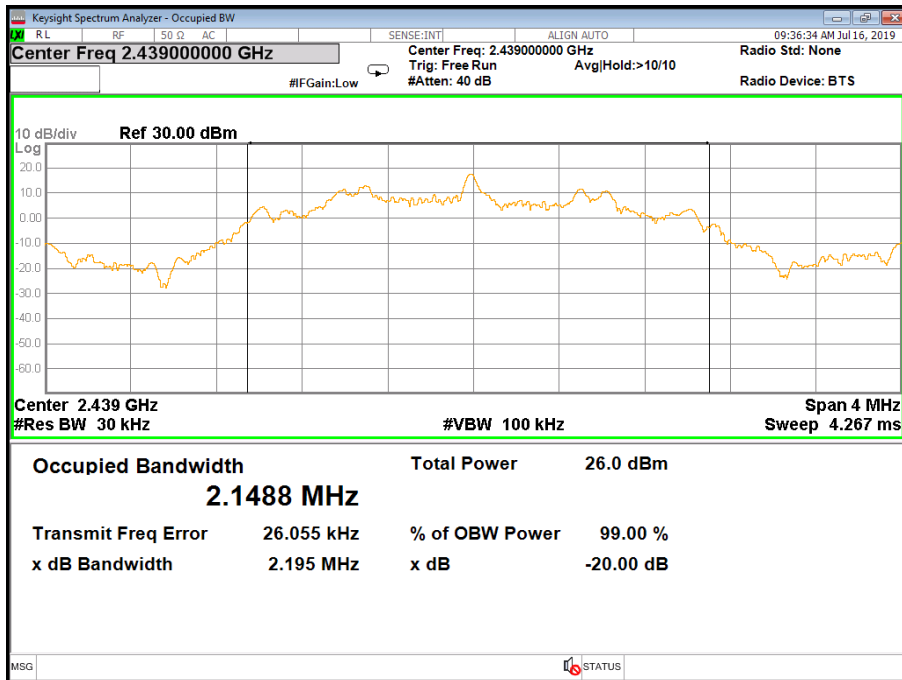

CH High

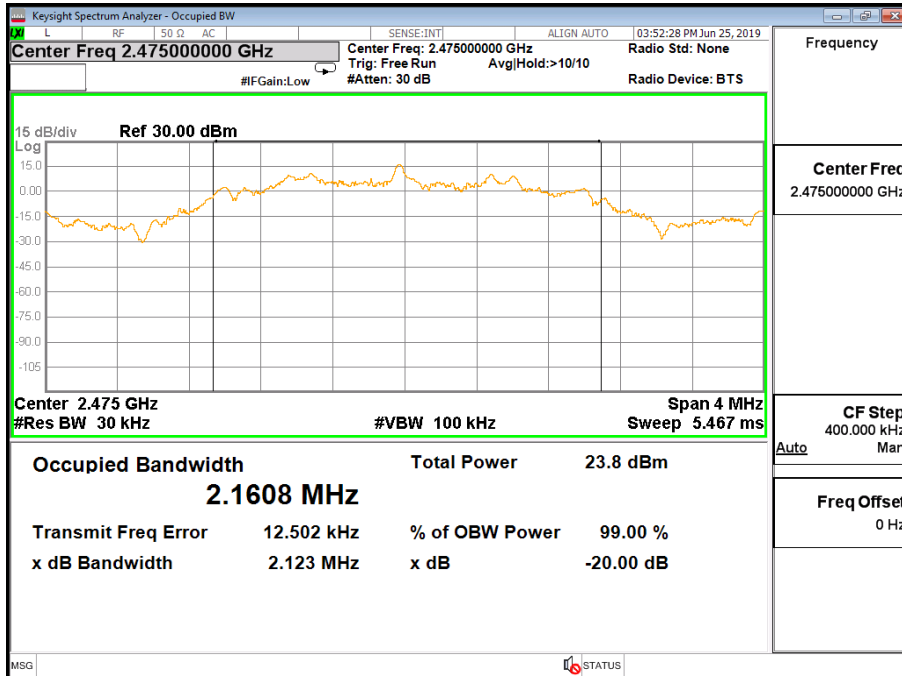

9 PEAK OUTPUT POWER TEST

9.1 APPLIED PROCEDURES / LIMIT

FCC Part 15.247, Subpart C RSS-247 Issue 2				
Section	Test Item	Limit	Frequency Range (MHz)	Result
FCC Part 15.247(a)(1) RSS-247 Clause 5.4(b)	Output Power	1 W or 0.125W if channel separation > 2/3 bandwidth provided the systems operate with an output power no greater than 125 mW (20.97dBm)	2400-2483.5	PASS

9.2 TEST PROCEDURE

- a. The EUT was directly connected to the Power Sensor & PC

9.3 DEVIATION FROM STANDARD

No deviation.

9.4 TEST SETUP

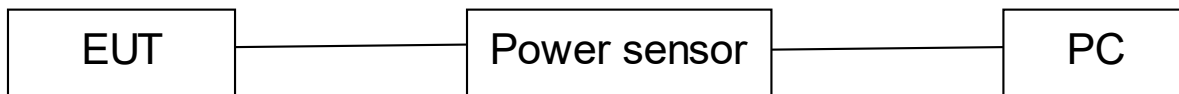

9.5 EUT OPERATION CONDITIONS

The EUT tested system was configured as the statements of 2.3 Unless otherwise a special operating condition is specified in the follows during the testing.

9.6 TEST RESULTS

Temperature :	25 °C	Relative Humidity :	60%
Test Voltage :	AC 120V/60Hz		

Test Channel	Frequency (MHz)	Conducted Output Power		Limit (dBm)
		Peak(dBm)	AVG(dBm)	
Low	2405	19.00	17.52	20.97
Middle	2439	19.07	17.59	20.97
High	2475	19.13	17.65	20.97

Note:

- 1) The cable loss and antenna gain are taken into account in results.
- 2) Antenna gain(G): 0 dBi
- 3) The max e.i.r.p = conducted power + antenna gain = 19.13 dBm

10 ANTENNA REQUIREMENT

10.1 STANDARD REQUIREMENT

15.203 and RSS-Gen Issue 5 requirement: For intentional device, according to 15.203 and RSS-Gen Issue 5: an intentional radiator shall be designed to ensure that no antenna other than that furnished by the responsible party shall be used with the device.

10.2 EUT ANTENNA

The EUT antenna is Integral Antenna. It comply with the standard requirement.