

6

5

4

3

2

1

REVISION RECORD			
LTR	ECO NO:	APPROVED:	DATE:

D

D

C

C

B

B

A

A

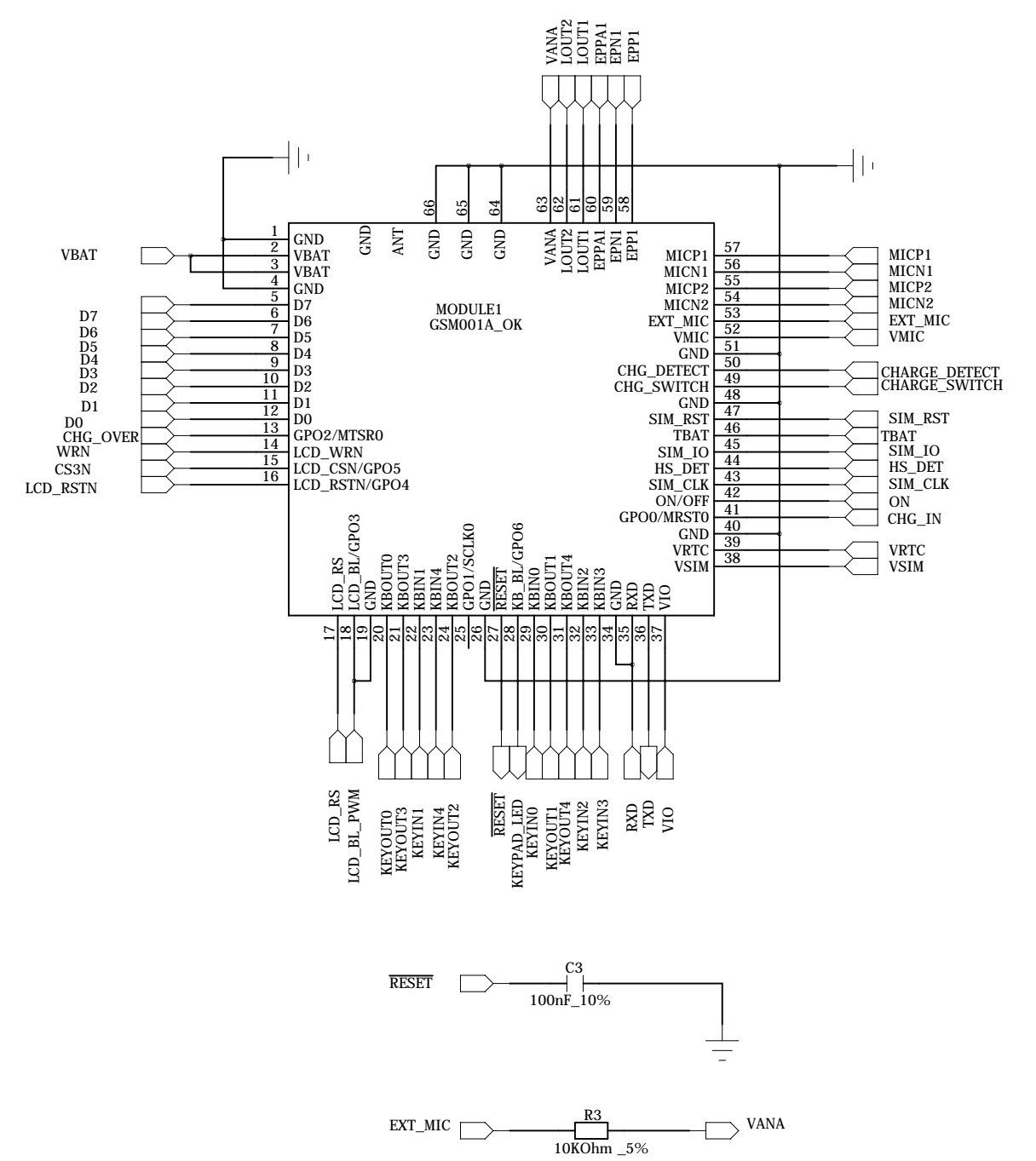
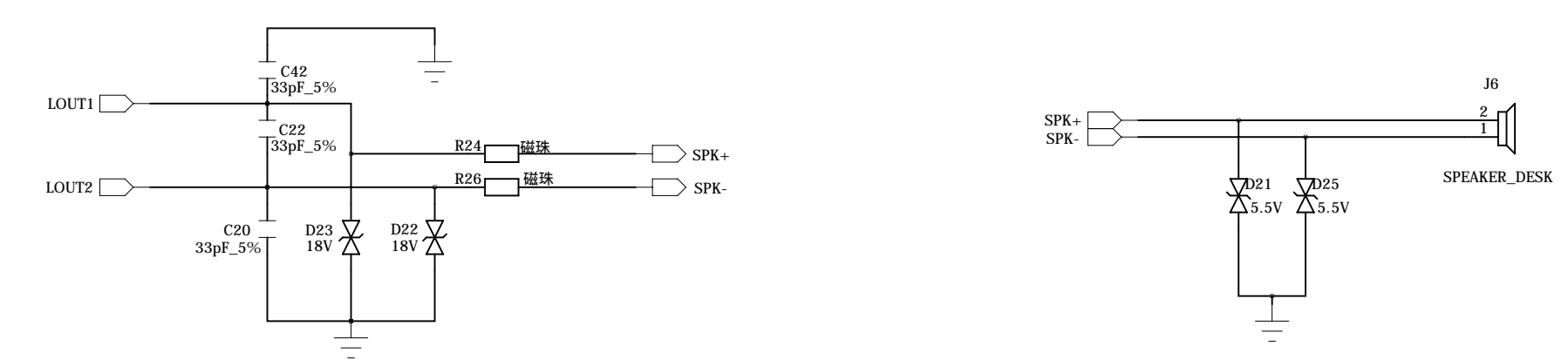
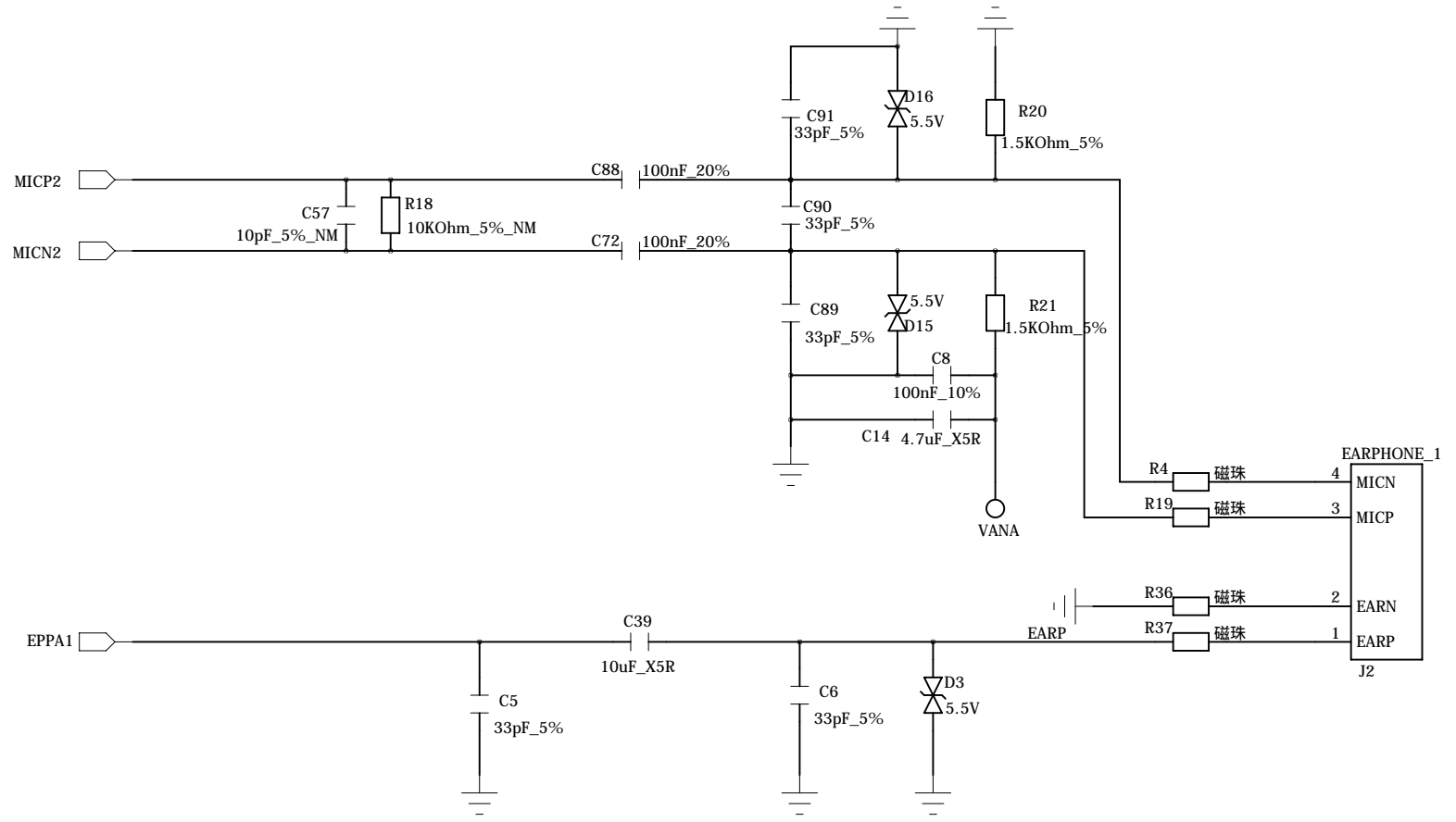
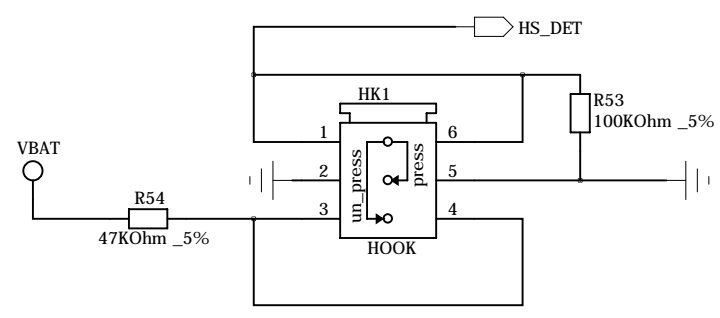
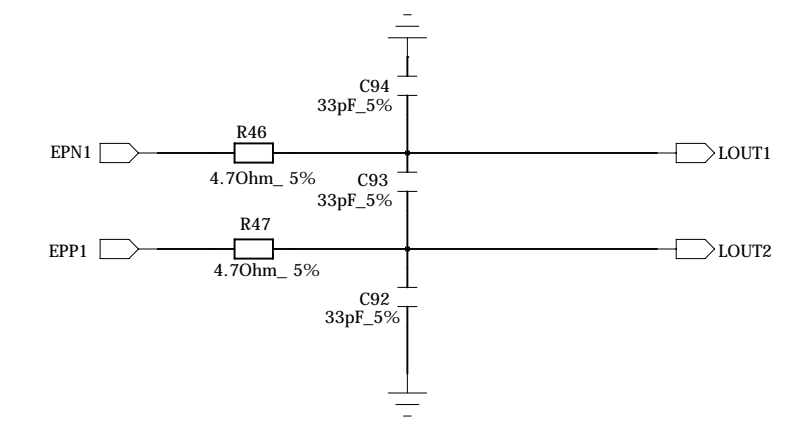
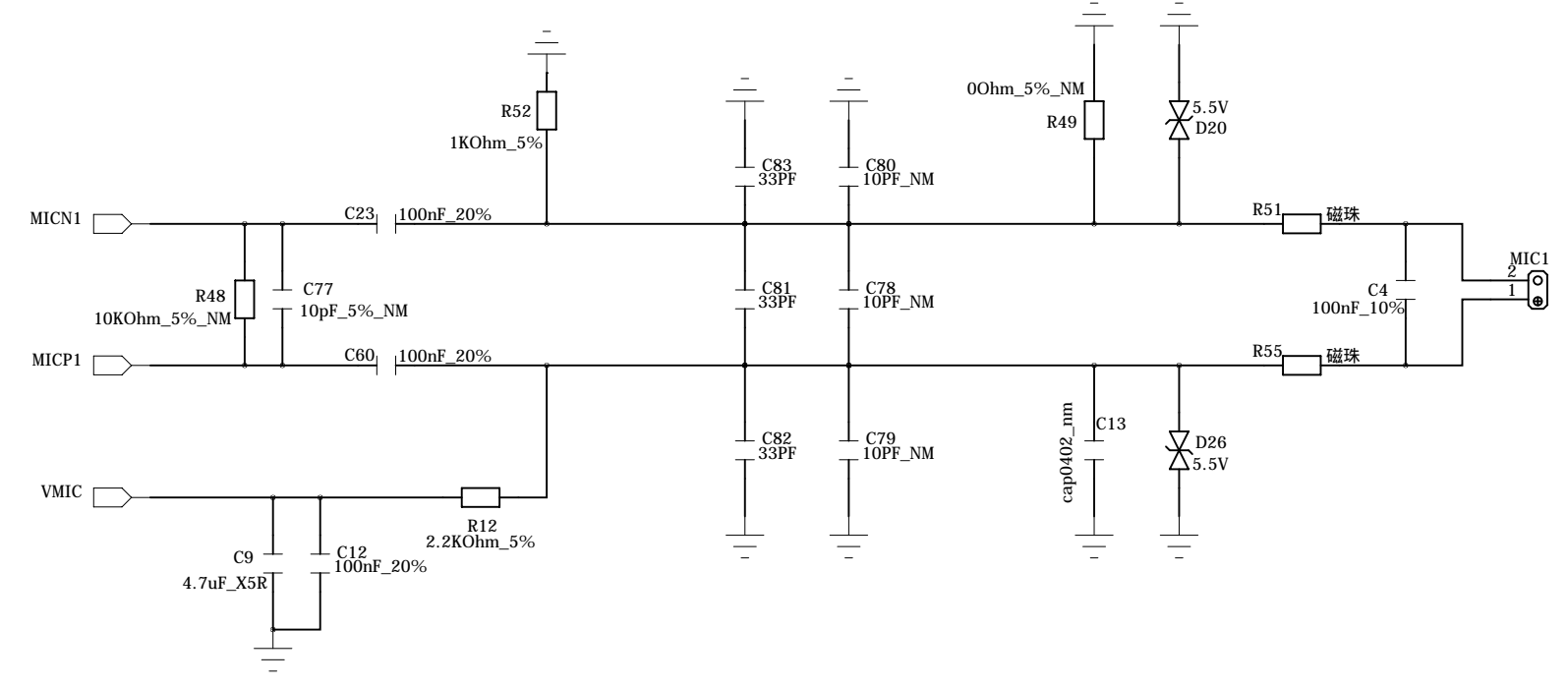

COMPANY: PuTian YiTong			
TITLE: Mainboard of GSM Desktop			
DRAWN: <Drawn By>	DATED: 2007-5-29	CODE: <Code>	SIZE: A2
CHECKED: <Checked By>	DATED: <Checked Date>	DRAWING NO: 2	REV: V0.1
QUALITY CONTROL: <QC By>	DATED: <QC Date>	SCALE: <Scale>	SHEET: 1 of 2
RELEASED: <Released By>	DATED: <Release Date>		

6

5

4

3

2

1

REVISION RECORD			
LTR	ECO NO.	APPROVED:	DATE:

LCD_INTERFACE

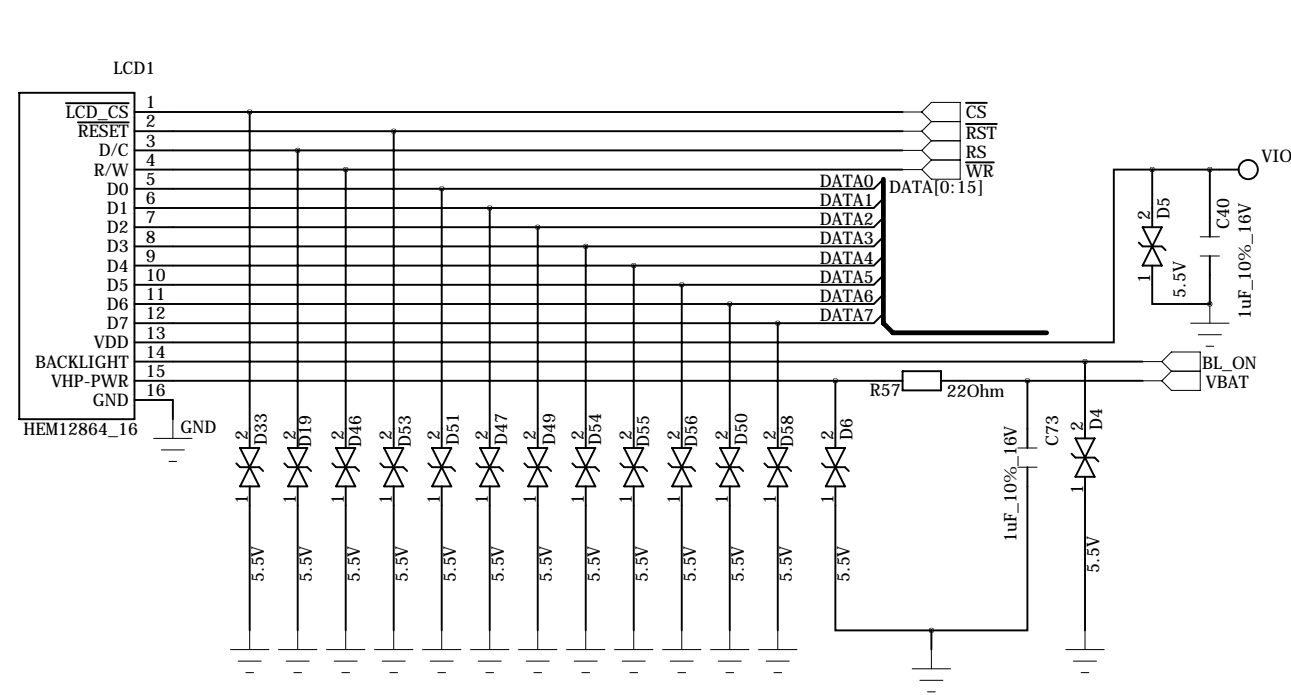

SIM_INTERFACE

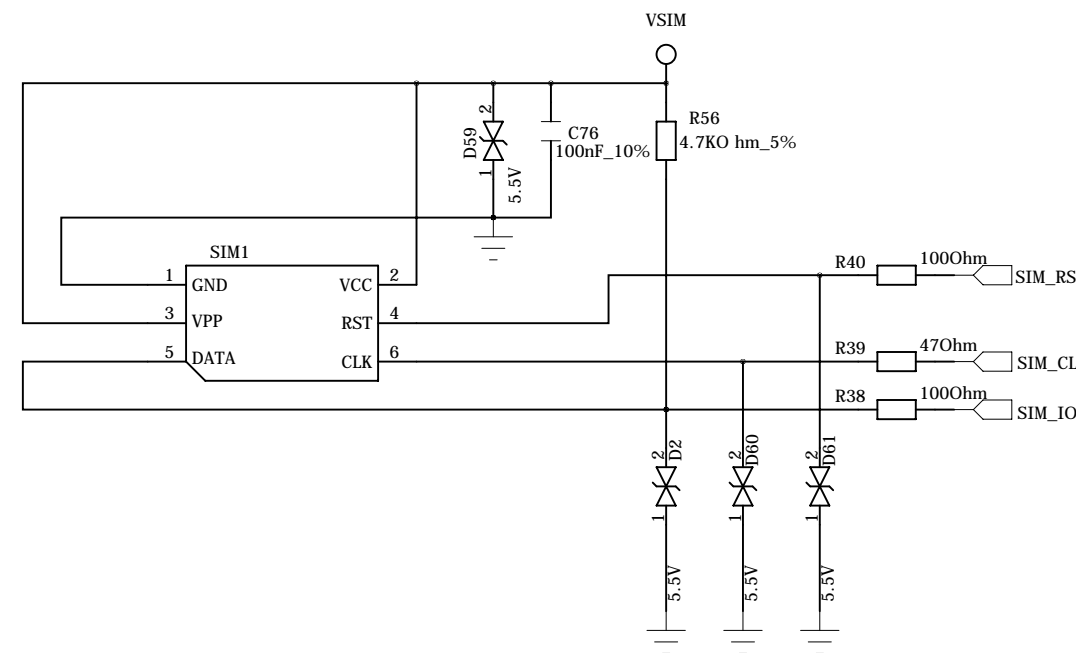

UART_INTERFACE

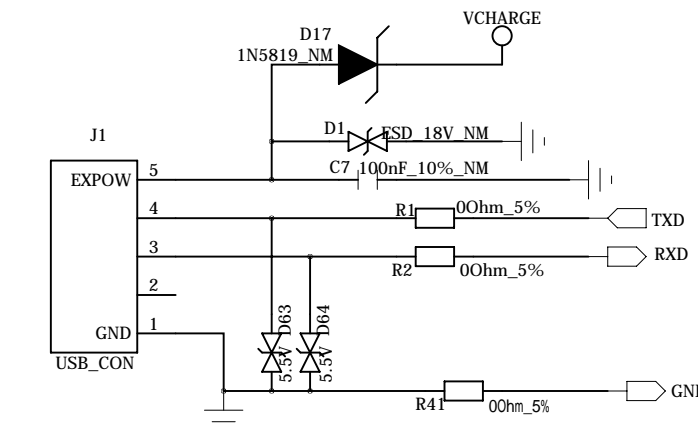

D

D

C

C

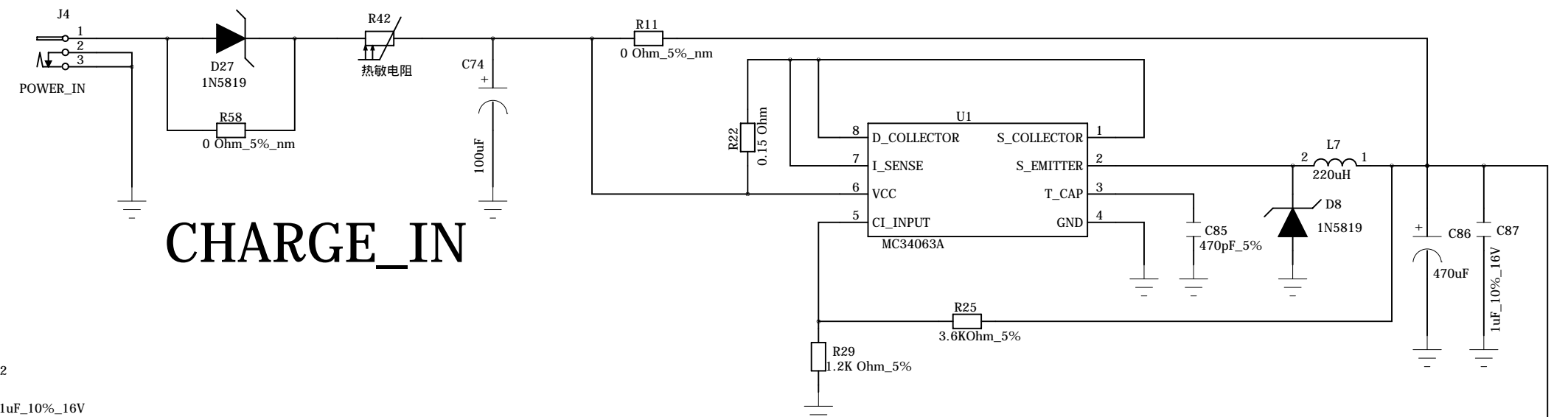
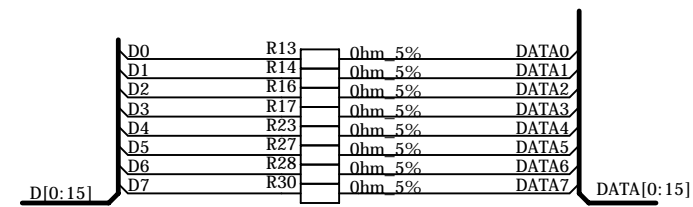

CHARGE_IN

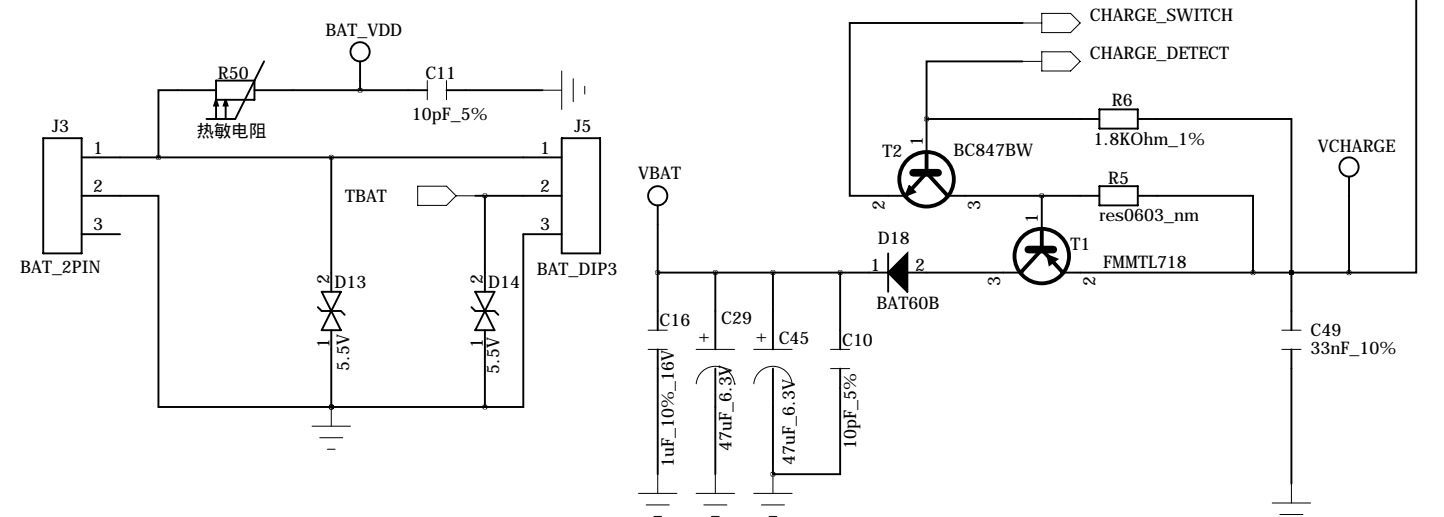
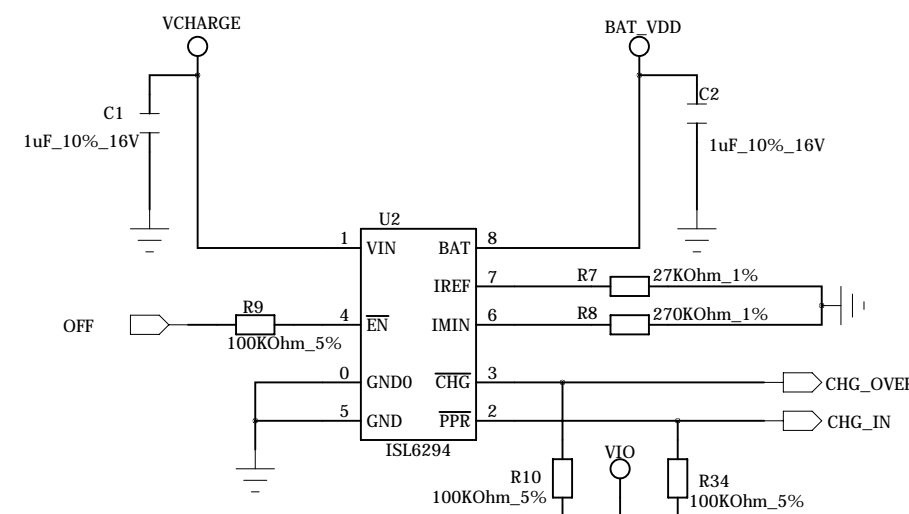

BATTERY_IN

B

B

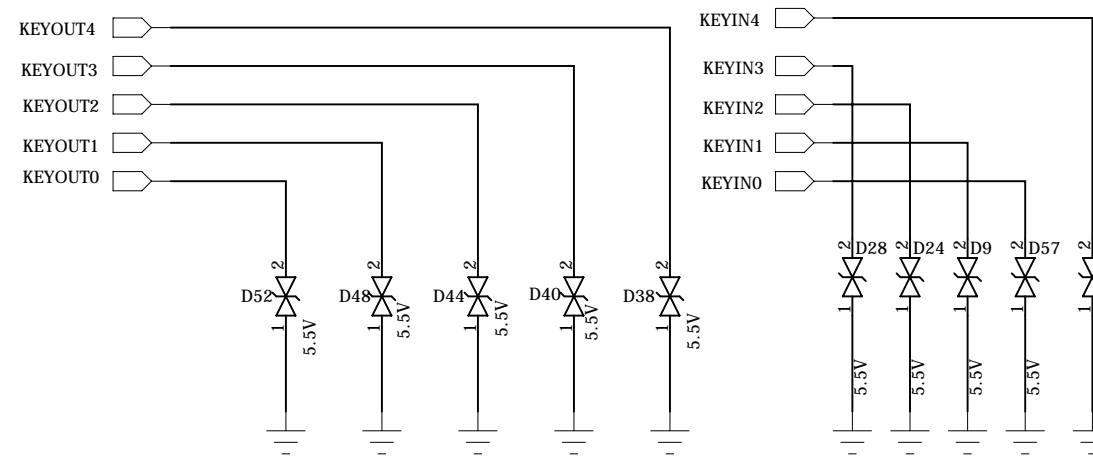
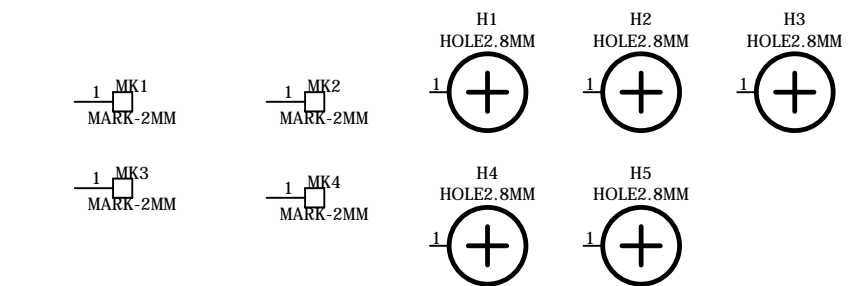

KEYBOARD_INTERFACE

A

A

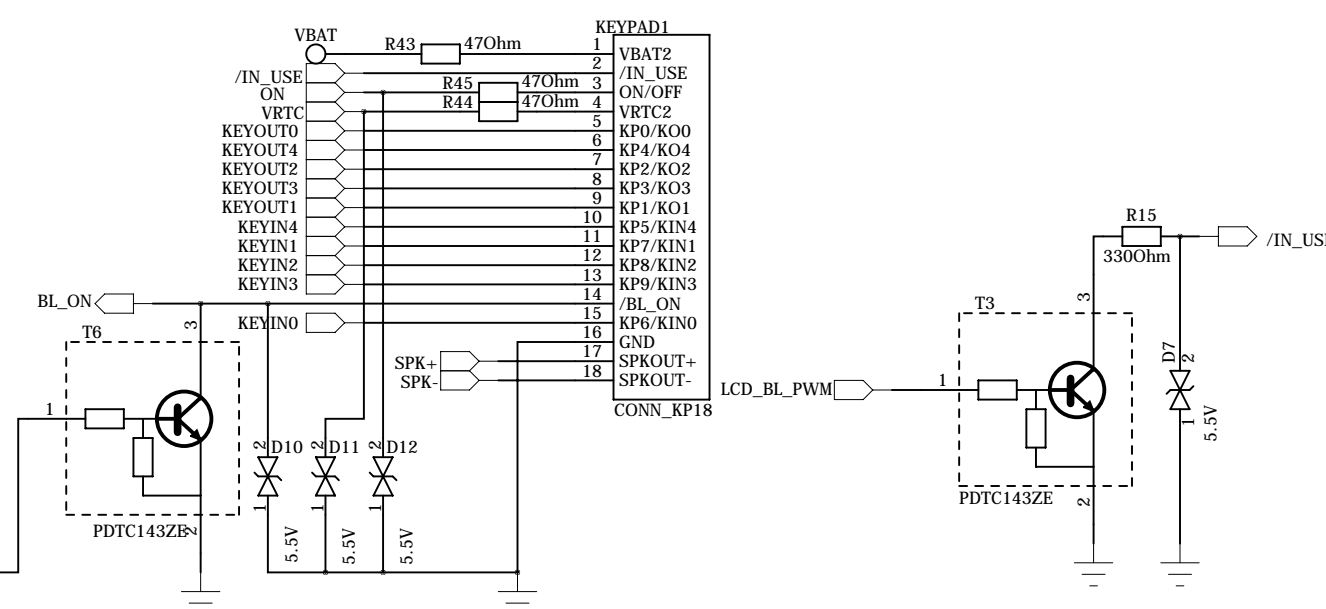

COMPANY: PuTian YiTong			
TITLE: Mainboard of GSM Desktop			
DRAWN: <Drawn By>	DATED: 2007-5-29	CODE: <Code>	SIZE: A2
CHECKED: <Checked By>	DATED: <Checked Date>	DRAWING NO: 2	REV: V0.1
QUALITY CONTROL: <QC By>	DATED: <QC Date>	SCALE: <Scale>	SHEET: 2 OF 2
RELEASED: <Released By>	DATED: <Release Date>		