



No.198 Kezhu Road, Science Town Economic& Technology
Development District Guangzhou, China 510663
Telephone: +86 (0) 20 82155555
Fax: +86 (0) 20 82075059
Email: sgs_internet_operations@sgs.com

FEDERAL COMMUNICATIONS COMMISSION
Registration number: 282399

Report No.: GLEMR070802391RFT
Page: 1 of 45
FCC ID: VJS-IMT525

TEST REPORT

Application No. : GLEMR070802391RF
Applicant: Altec Lansing a Division of Plantronics, Inc.
FCC ID: VJS-IMT525
Fundamental Carrier Frequency : 2.402GHz to 2.480GHz
Equipment Under Test (EUT):
Name: Bluetooth Speaker
Model: iMT525 ; iMT521 ♣
♣ Please refer to section 2 of this report which indicates which item was actually tested and which were electrically identical.
Serial No.: Not supplied by client
Standards: FCC PART 15, SUBPART C: 2006 (Section 15.247);
FCC PART 15, SUBPART B: 2006.
Date of Receipt: 02 August 2007
Date of Test: 03 to 18 August 2007
Date of Issue: 23 August 2007

Test Result :	PASS *
----------------------	---------------

* In the configuration tested, the EUT complied with the standards specified above.

Authorized Signature:

Stephen Guo
Manager

This report refers to the General Conditions for Inspection and Testing Services, printed overleaf
This report details the results of the testing carried out on one sample. The results contained in this test report do not relate to other samples of the same product. The manufacturer should ensure that all products in series production are in conformity with the product sample detailed in this report.
This report may only be reproduced and distributed in full. If the product in this report is used in any configuration other than that detailed in the report, the manufacturer must ensure the new system complies with all relevant standards. Any mention of SGS International Electrical Approvals or testing done by SGS International Electrical Approvals in connection with, distribution or use of the product described in this report must be approved by SGS International Electrical Approvals in writing.



2 Test Summary

Test	Test Requirement	Standard Paragraph	Result
Maximum Peak Output Power	FCC PART 15 :2006	Section 15.247 (b1)	PASS
Conducted Emission (150KHz to 30MHz)	FCC PART 15 :2006	Section 15.107 Section 15.207	PASS
Conducted Spurious Emission (30MHz to 25GHz)	FCC PART 15 :2006	Section 15.247 (d)	PASS
Radiated Spurious Emission (30MHz to 25GHz)	FCC PART 15 :2006	Section 15.109 Section 15.209	PASS
Band Edges Measurement	FCC PART 15 :2006	Section 15.247 (c)	PASS
Hopping Channel Number	FCC PART 15 :2006	Section 15.247 (b1)	PASS
Occupied Bandwidth	FCC PART 15 :2006	Section 15.247 (a1)	PASS
Carrier Frequencies Separated	FCC PART 15 :2006	Section 15.247 (a1,iii)	PASS
Dell Time	FCC PART 15 :2006	Section 15.247 (a1)	PASS
Antenna Requirement	FCC PART 15 :2006	Section 15.247 (b)(c)	PASS

♣Remark:

Model: iMT525, iMT521

Only the Item **iMT525** was tested, since the electrical circuit design, PCB layout, components used and internal wiring were identical for the above items, model numbers were different according to declaration by the applicant.



3 Contents

	Page
1 COVER PAGE	1
2 TEST SUMMARY	2
3 CONTENTS	3
4 GENERAL INFORMATION	4
4.1 CLIENT INFORMATION.....	4
4.2 GENERAL DESCRIPTION OF E.U.T.	4
4.3 DESCRIPTION OF SUPPORT UNITS	4
4.4 STANDARDS APPLICABLE FOR TESTING.....	4
4.5 TEST LOCATION.....	4
4.6 OTHER INFORMATION REQUESTED BY THE CUSTOMER	4
4.7 TEST FACILITY	5
5 EQUIPMENTS USED DURING TEST.....	6
6 TEST RESULTS	7
6.1 E.U.T. OPERATION	7
6.2 CONDUCTED EMISSIONS MAINS TERMINALS, 150KHZ TO 30MHZ.....	8
6.3 MAXIMUM PEAK OUTPUT POWER	13
6.4 CONDUCTED SPURIOUS EMISSIONS.....	16
6.5 RADIATED SPURIOUS EMISSIONS.....	20
6.5.1 <i>Harmonics Emissions</i>	22
6.6 RADIATED EMISSIONS	26
6.7 BAND EDGES REQUIREMENT	27
6.7.1 <i>100 kHz Bandwidth Outside the Frequency Band</i>	27
6.7.2 <i>Radiated Emissions which fall in the restricted bands</i>	29
6.8 HOPPING CHANNEL NUMBER.....	34
6.9 OCCUPIED BANDWIDTH.....	35
6.10 CARRIER FREQUENCIES SEPARATED	37
6.11 DWELL TIME	39
6.12 ANTENNA REQUIREMENT.....	45
6.12.1 <i>Standard Applicable</i>	45
6.12.2 <i>Antenna Construction</i>	45



4 General Information

4.1 Client Information

Applicant Name: Altec Lansing, a Division of Plantronics, Inc.
Applicant Address: 535 Routes 6 & 209, Milford, PA United States.

4.2 General Description of E.U.T.

Product Name: Bluetooth Speaker
Model: iMT525; iMT525
Bluetooth Specification: Bluetooth V1.2
Number of Channels 79 Channels
Channel Separation 1 MHz
Type of Modulation FHSS (Frequency Hopping Spread Spectrum);
Adaptive Frequency Hopping (AFH) is used.
Dwell time Per channel is less than 0.4S.
Antenna Type Integral
Power supply: Batteries supplied: 9VDC (6 x "AA" size batteries) or
AC/DC Adapter supplied.
Adapter information Model no.: S012BU900160; input AC100V~240V; output: DC 9.0V;
Adapter DC output cable: 1.5m x 2 wires unshielded cable.
Which provide the applicant.

4.3 Description of Support Units

The EUT has been tested as an independent unit.

4.4 Standards Applicable for Testing

The customer requested FCC tests for a speaker with Bluetooth function.
The standard used was FCC PART 15, SUBPART B&C.

4.5 Test Location

All tests were performed at:

SGS-CSTC Standards Technical Services Co., Ltd., Guangzhou EMC Laboratory, No.198 Kezhu Road, Science Town Economic& Technology Development District Guangzhou, China 510663

Tel: +86 20 82155555 Fax: +86 20 82075059

No tests were sub-contracted.

4.6 Other Information Requested by the Customer

None.



4.7 Test Facility

The test facility is recognized, certified, or accredited by the following organizations:

- **NVLAP – Lab Code: 200611-0**
SGS-CSTC Standards Technical Services Co., Ltd., Guangzhou EMC Laboratory is recognized under the National Voluntary Laboratory Accreditation Program (NVLAP/NIST). NVLAP Code: 200611-0. Effective through December 31, 2006.
- **FCC – Registration No.: 282399**
SGS-CSTC Standards Technical Services Co., Ltd., EMC Laboratory has been registered and fully described in a report filed with the (FCC) Federal Communications Commission. The acceptance letter from the FCC is maintained in our files. Registration 282399, May 31, 2002. With the above and NVLAP, SGS-CSTC is an authorized test laboratory for the DoC process.



5 Equipments Used during Test

Conducted Emission						
No:	Test Equipment	Manufacturer	Model No.	Serial No.	Cal. Date (dd-mm-yy)	Cal.Due date (dd-mm-yy)
EMC0306	Shielding Room	Zhong Yu	8 x 3 x 3.8 m ³	N/A	N/A	N/A
EMC0102	LISN	Schaffner Chase	MNZ050D/1	1421	05-12-2006	05-12-2007
EMC0506	EMI Test Receiver	Rohde & Schwarz	ESCS30	100085	05-12-2006	05-12-2007
EMC0107	Coaxial Cable	SGS	2m	N/A	25-11-2006	25-11-2007
EMC0106	Voltage Probe	SGS	N/A	N/A	N/A	N/A

RE in Chamber/OATS						
No:	Test Equipment	Manufacturer	Model No.	Serial No.	Cal. Date (dd-mm-yy)	Cal.Due date (dd-mm-yy)
EMC0525	Compact Semi-Anechoic Chamber	ChangZhou ZhongYu	N/A	N/A	06-03-2007	06-03-2008
EMC0522	EMI Test Receiver	Rohde & Schwarz	ESIB26	100249	05-12-2006	05-12-2007
N/A	EMI Test Software	Audix	E3	N/A	N/A	N/A
EMC0514	Coaxial cable	SGS	N/A	N/A	04-12-2006	04-12-2007
EMC0524	Bi-log Type Antenna	Schaffner -Chase	CBL6112B	2966	12-08-2007	12-08-2008
EMC0519	Bilog Type Antenna	Schaffner -Chase	CBL6143	5070	12-08-2007	12-08-2008
EMC0517	Horn Antenna	Rohde & Schwarz	HF906	100095	12-08-2007	12-08-2008
EMC0040	Spectrum Analyzer	Rohde & Schwarz	FSP30	100324	05-12-2006	05-12-2007
EMC0520	0.1-1300 MHz Pre-Amplifier	HP	8447D OPT 010	2944A06252	28-03-2007	28-03-2008
EMC0521	1-26.5 GHz Pre-Amplifier	Agilent	8449B	3008A01649	28-03-2007	28-03-2008
EMC0523	Active Loop Antenna	EMCO	6502	00042963	09-08-2006	09-08-2008
EMC0530	10m Semi- Anechoic Chamber	ETS	N/A	N/A	22-08-2006	22-08-2007

General used equipment						
No:	Test Equipment	Manufacturer	Model No.	Serial No.	Cal. Date (dd-mm-yy)	Cal.Due date (dd-mm-yy)
EMC0050-EMC0053	Temperature, & Humidity	ZHENGZHOU BO YANG	WSB	N/A	05-12-2006	05-12-2007
EMC0054	Temperature, & Humidity	Shenzhen Tai Kong	THG-1	N/A	04-01-2007	04-01-2008
EMC0006	DMM	Fluke	73	70681569	27-09-2006	27-09-2007
EMC0007	DMM	Fluke	73	70671122	27-09-2006	27-09-2007



6 Test Results

6.1 E.U.T. Operation

Input voltage: Batteries supplied: 9VDC (6 x "AA" size batteries) or
AC/DC Adapter supplied: Input 120V AC/ 60Hz.

Operating Environment:

Temperature: 24.0 -25.0 °C

Humidity: 50-56 % RH

Atmospheric Pressure: 1008 -1012 mbar

EUT Operation:

Test the EUT as a product which has frequency hopping system. The total hopping channels are 79 channels (0 to 78 channels), the fundamental frequencies are from 2.402GHz to 2.480GHz.

The test procedure provided by applicant enabled the EUT to transmit and receive data at lowest (**Channel 0: 2.402GHz**), middle (**Channel 39: 2.441GHz**) and highest channel (**Channel 78: 2.480GHz**), frequencies individually.



6.2 Conducted Emissions Mains Terminals, 150kHz to 30MHz

Test Requirement: FCC 15.207 & FCC 15.107
Test Method: ANSI C63.4.
Test Date: 14 August 2007
Frequency Range: 150KHz to 30MHz
Class / Severity: Class B
Detector: Peak for pre-scan (9kHz Resolution Bandwidth)
Quasi-Peak if maximised peak within 6dB of Quasi-Peak limit
EUT Operation: Test in 1. AUX in mode; 2.Test in Bluetooth function on.



LISN line with Aux in

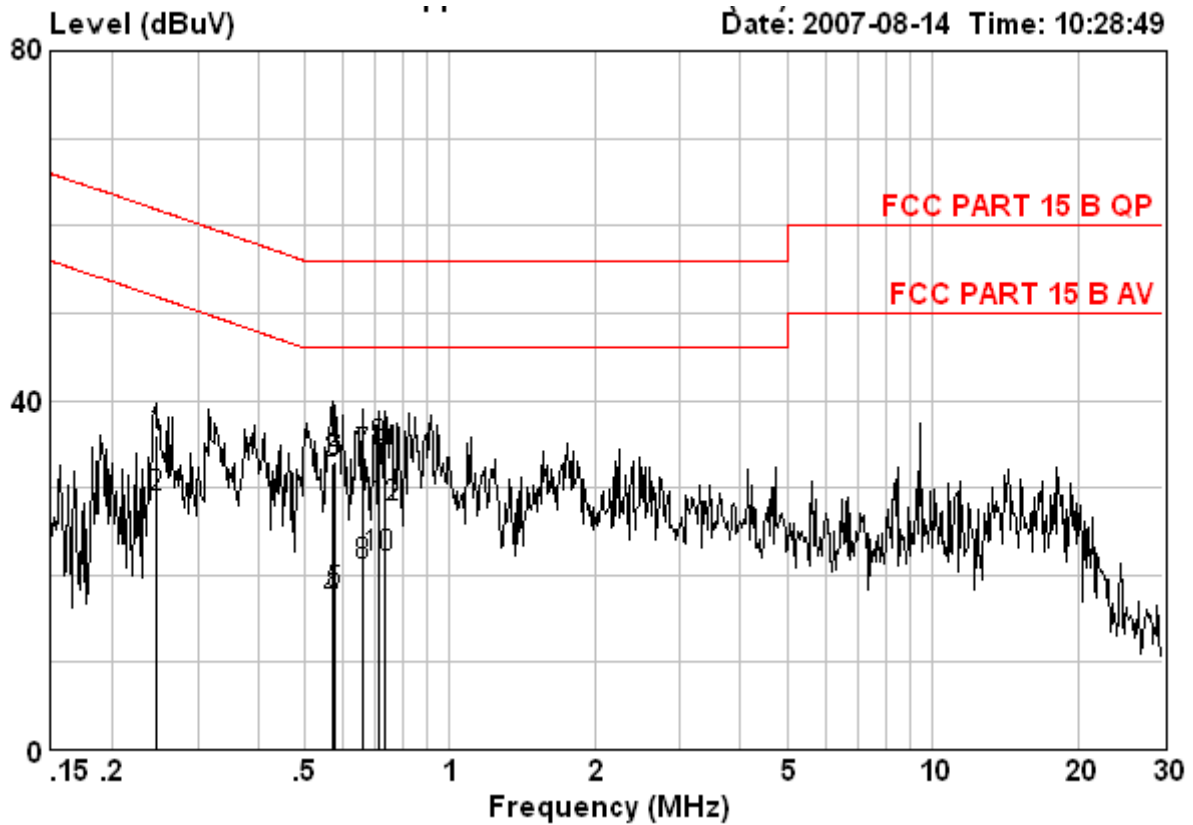

	Read Freq	Cable Loss	LISN Factor	Limit Line	Over Limit	Remark
	MHz	dB	dB	dBuV	dB	
1	0.246	35.83	0.00	0.10	35.93	61.91 -25.98 QP
2	0.246	28.88	0.00	0.10	28.98	51.91 -22.93 AVERAGE
3	0.570	32.67	0.00	0.06	32.73	56.00 -23.27 QP
4	0.570	17.00	0.00	0.06	17.06	46.00 -28.94 AVERAGE
5	0.579	17.86	0.00	0.06	17.92	46.00 -28.08 AVERAGE
6	0.579	32.97	0.00	0.06	33.03	56.00 -22.97 QP
7	0.658	33.73	0.00	0.02	33.75	56.00 -22.25 QP
8	0.658	21.12	0.00	0.02	21.14	46.00 -24.86 AVERAGE
9	0.712	34.56	0.00	0.00	34.56	56.00 -21.44 QP
10	0.712	21.99	0.00	0.00	21.99	46.00 -24.01 AVERAGE
11	0.731	33.89	0.00	0.01	33.90	56.00 -22.10 QP
12 @	0.731	27.82	0.00	0.01	27.83	46.00 -18.17 AVERAGE



Neutral Line with Aux in

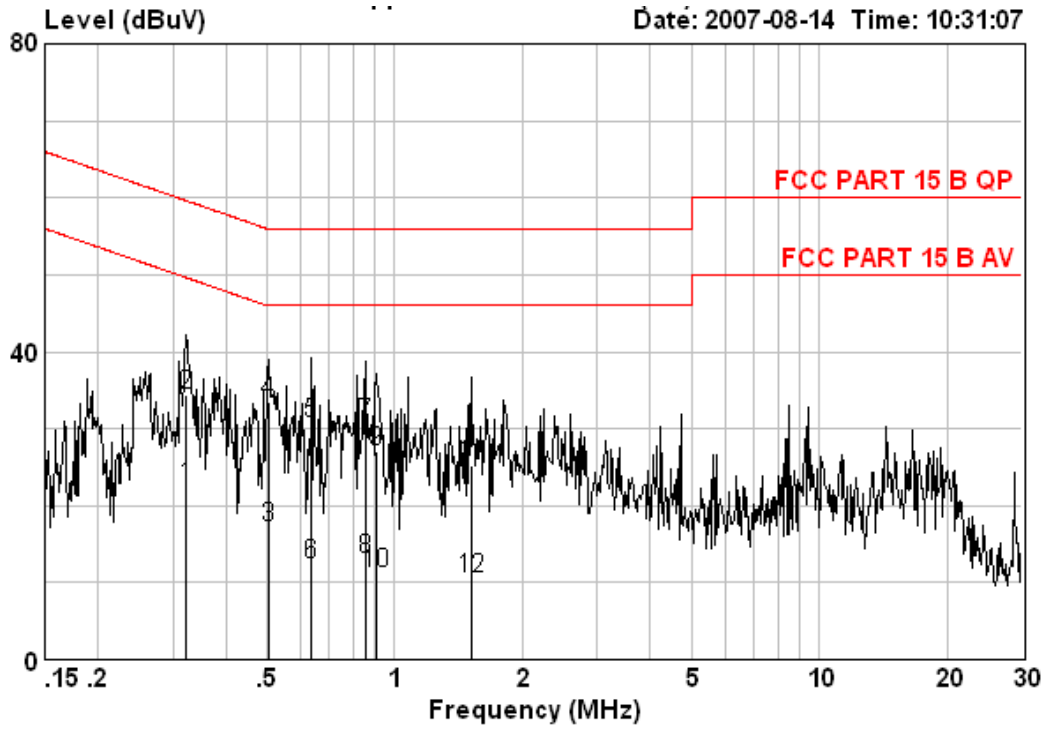

	Freq	Read Level	Cable Loss	LISN Factor	Level	Limit Line	Over Limit	Remark
	MHz	dBuV	dB	dB	dBuV	dBuV	dB	
1	0.322	22.38	0.00	0.10	22.48	49.66	-27.18	AVERAGE
2	0.322	34.25	0.00	0.10	34.35	59.66	-25.31	QP
3	0.507	17.15	0.00	0.10	17.25	46.00	-28.75	AVERAGE
4	0.507	33.31	0.00	0.10	33.41	56.00	-22.59	QP
5	0.637	30.74	0.00	0.03	30.77	56.00	-25.23	QP
6	0.637	12.30	0.00	0.03	12.33	46.00	-33.67	AVERAGE
7	0.853	30.57	0.00	0.05	30.62	56.00	-25.38	QP
8	0.853	12.92	0.00	0.05	12.97	46.00	-33.03	AVERAGE
9	0.909	26.91	0.00	0.07	26.98	56.00	-29.02	QP
10	0.909	11.06	0.00	0.07	11.13	46.00	-34.87	AVERAGE
11	1.511	25.24	0.02	0.04	25.30	56.00	-30.70	QP
12	1.511	10.39	0.02	0.04	10.45	46.00	-35.55	AVERAGE



Neutral line with Bluetooth

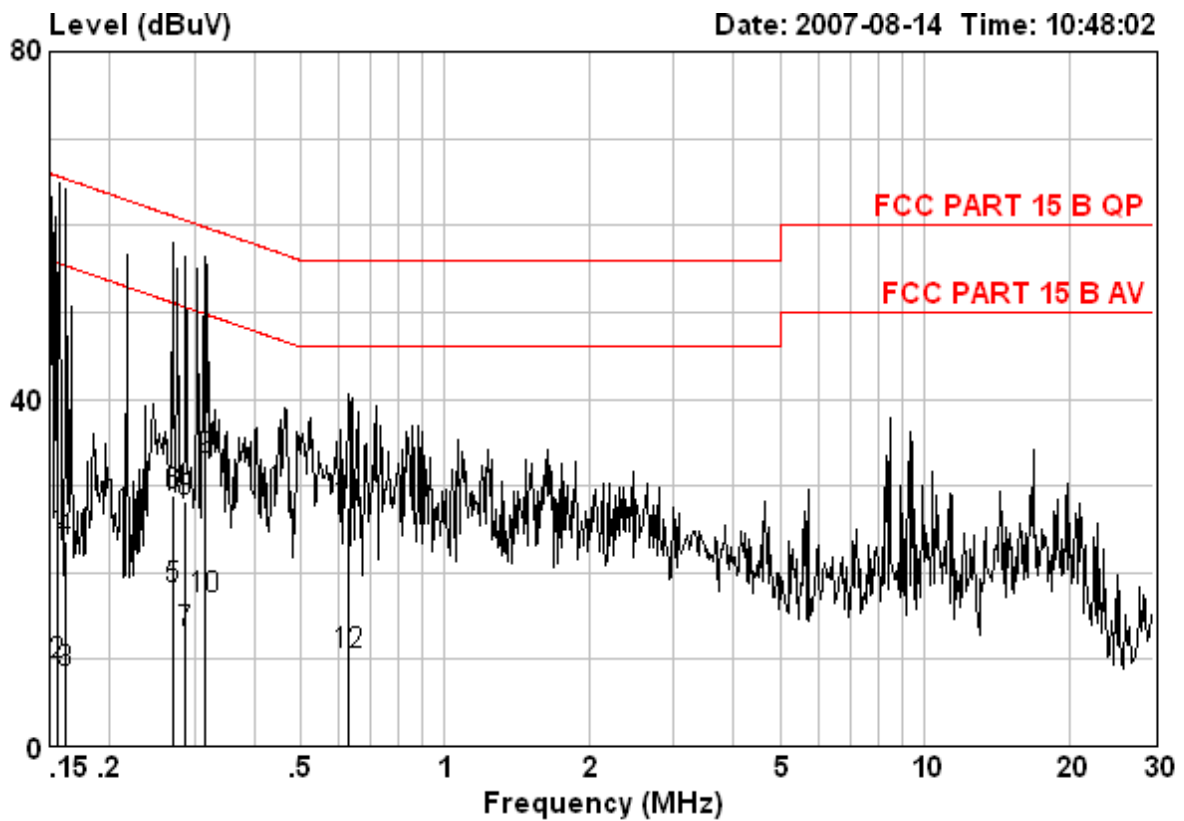

	Read Freq	Read Level	Cable Loss	LISN Factor	Level	Limit Line	Over Limit	Remark
	MHz	dBuV	dB	dB	dBuV	dBuV	dB	
1	0.156	24.03	0.00	0.10	24.13	65.65	-41.52	QP
2	0.156	9.24	0.00	0.10	9.34	55.65	-46.31	AVERAGE
3	0.162	8.48	0.00	0.10	8.58	55.34	-46.76	AVERAGE
4	0.162	23.42	0.00	0.10	23.52	65.34	-41.82	QP
5	0.270	17.95	0.00	0.10	18.05	51.12	-33.07	AVERAGE
6	0.270	28.75	0.00	0.10	28.85	61.12	-32.27	QP
7	0.288	12.97	0.00	0.10	13.07	50.59	-37.52	AVERAGE
8	0.288	28.04	0.00	0.10	28.14	60.59	-32.45	QP
9	0.315	32.98	0.00	0.10	33.08	59.84	-26.76	QP
10	0.315	16.91	0.00	0.10	17.01	49.84	-32.83	AVERAGE
11	0.627	27.59	0.00	0.03	27.62	56.00	-28.38	QP
12	0.627	10.46	0.00	0.03	10.49	46.00	-35.51	AVERAGE



LISN Line with Bluetooth

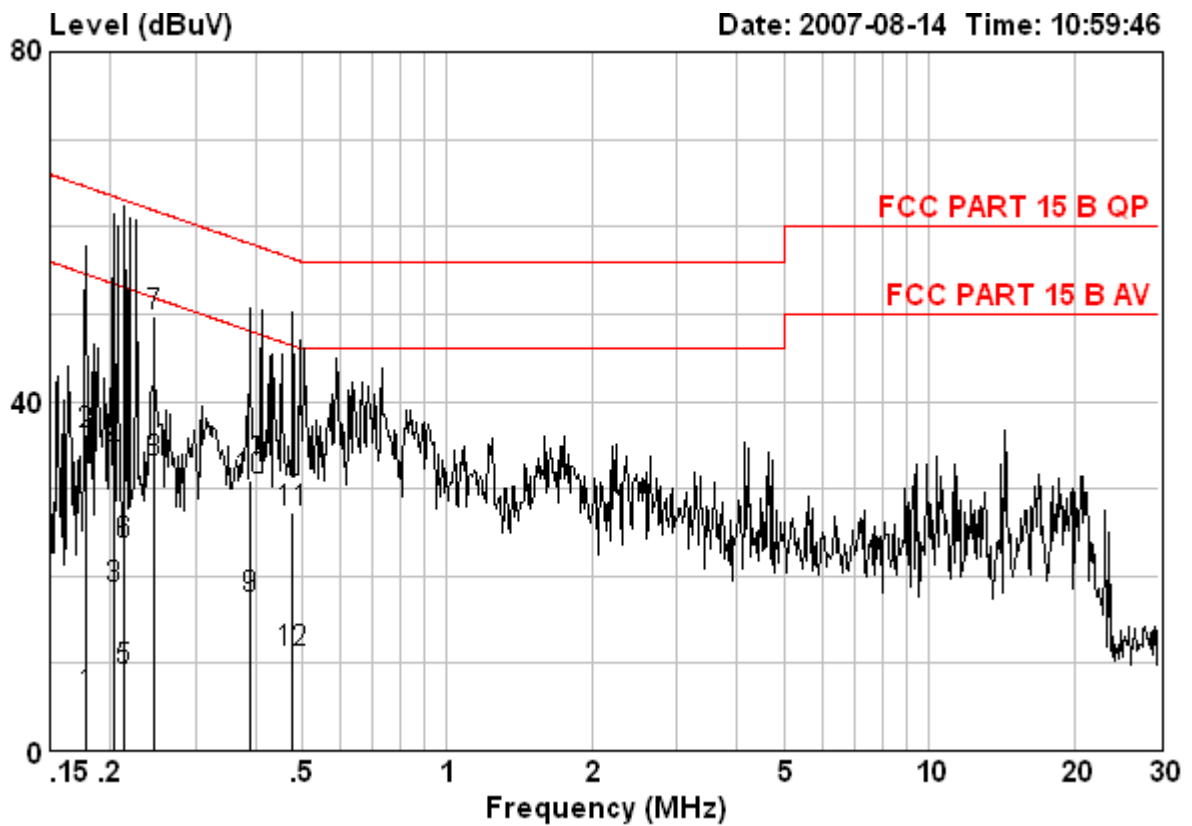

	Read Freq	Cable Loss	LISN Factor	Limit Line	Over Limit	Remark
	MHz	dB	dB	dBuV	dB	
1	0.179	6.17	0.06	54.55	-48.32	AVERAGE
2	0.179	36.13	0.06	64.55	-28.36	QP
3	0.203	18.54	0.10	53.49	-34.85	AVERAGE
4	0.203	33.84	0.10	63.49	-29.55	QP
5	0.214	9.11	0.10	53.05	-43.84	AVERAGE
6	0.214	23.58	0.10	63.05	-39.37	QP
7 @	0.247	49.54	0.10	61.87	-12.23	QP
8	0.247	33.02	0.10	51.87	-18.75	AVERAGE
9	0.389	17.37	0.10	48.08	-30.61	AVERAGE
10	0.389	30.82	0.10	58.08	-27.16	QP
11	0.479	27.12	0.10	56.36	-29.14	QP
12	0.479	11.20	0.10	46.36	-35.06	AVERAGE

6.3 Maximum Peak Output Power

Test Requirement: FCC Part15 C
 Test Method: Base on ANSI 63.4.
 Test Date: 15 Aug 2007
 Test Limit: Regulation 15.247 (b) The Limit of Maximum Peak Output Power For frequency hopping systems operating in the 2400-2483.5 MHz band employing at least 75 non-overlapping hopping channels, and all frequency hopping systems in the 5725-5850 MHz band: 1 watt. For all other frequency hopping systems in the 2400-2483.5 MHz band: 0.125 watts.

Test mode: Test in transmitting mode: Channel 0, Channel 39, Channel 78.

Test Configuration:

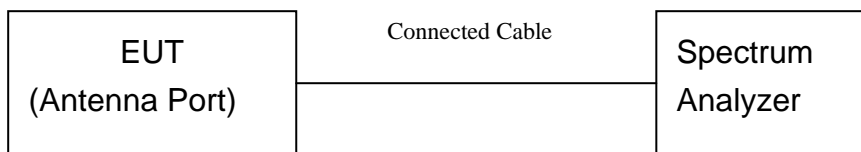

Test Procedure:

1. Remove the antenna from the EUT and then connect a low RF cable from the antenna port to the spectrum.
2. Set the spectrum analyzer: RBW = 1 MHz, VBW = 1 MHz, Sweep = auto; Detector Function = Peak.
3. Keep the EUT in transmitting at lowest, medium and highest channel individually. Record the max. reading.

Test Result:

Test Channel	Fundamental Frequency (GHz)	Reading Power (dBm)	Cable Loss (dB)	Output Power (dBm)	Limit (dBm)	PASS/FAIL
0	2.402	1.10	0.20	1.30	30.0	Pass
39	2.441	1.40	0.20	1.60	30.0	Pass
78	2.480	0.68	0.20	0.88	30.0	Pass

TEST RESULTS: The unit does meet the FCC requirements.



Max. Power Output Data Plot:

1. Lowest Channel:

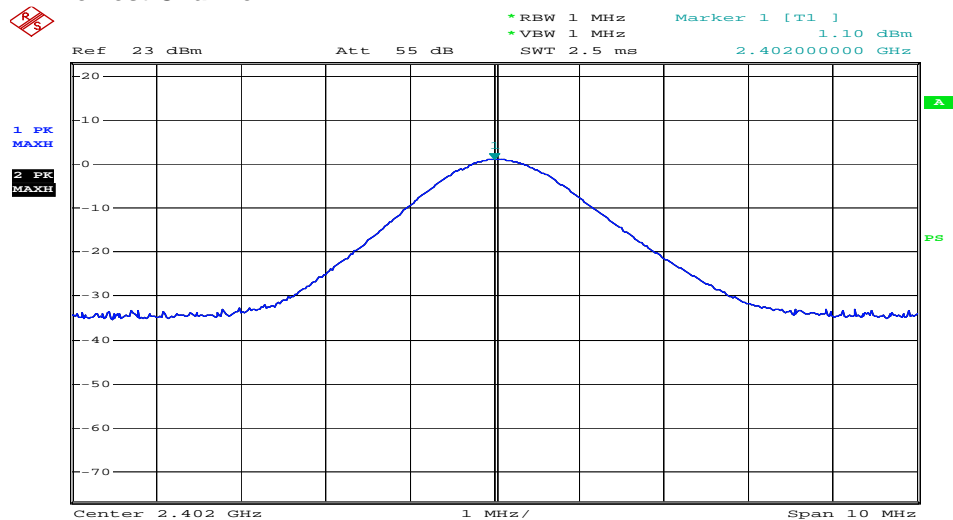

Date: 15.AUG.2007 13:44:05

2. Medium Channel:

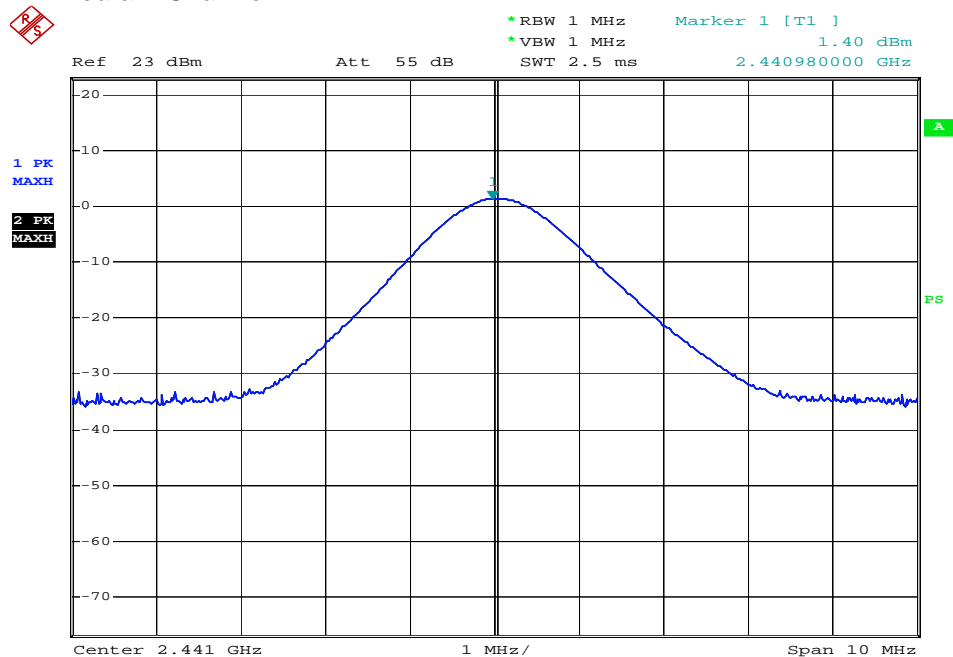

Date: 15.AUG.2007 13:45:06



3. Highest Channel:

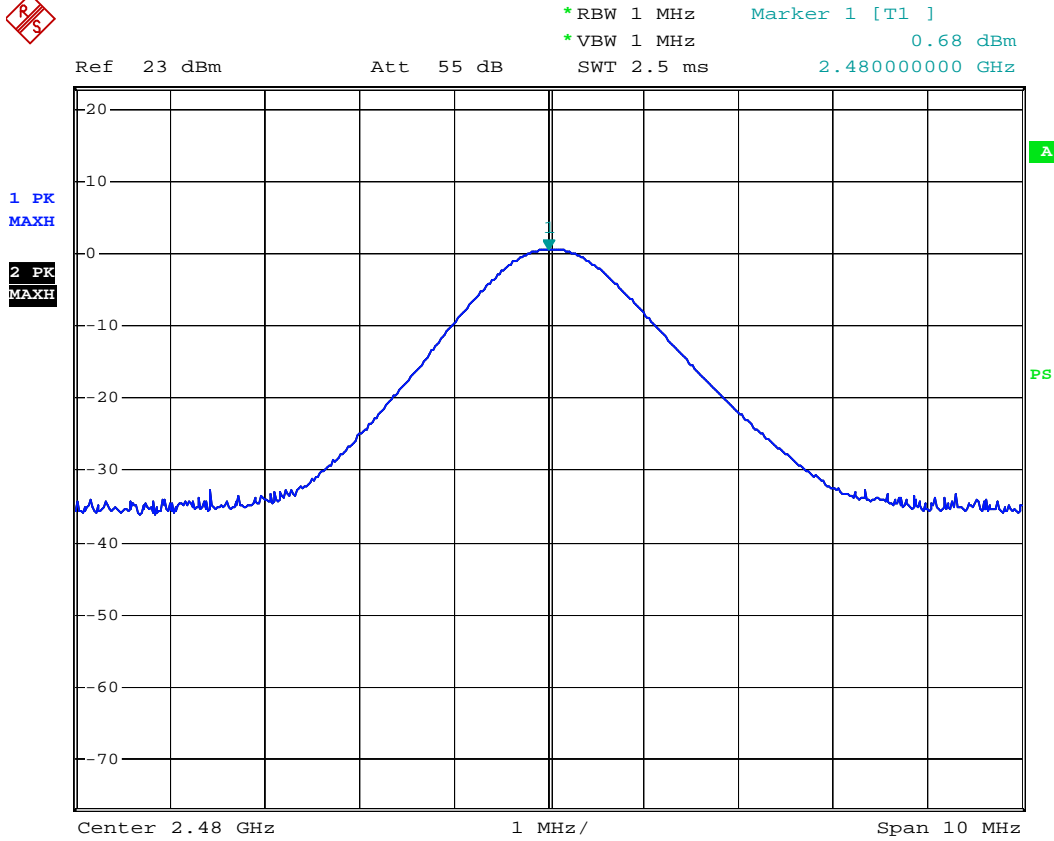

Date: 15.AUG.2007 13:45:52



6.4 Conducted Spurious Emissions

Test Requirement: FCC Part 15 C

Test Method: Based on FCC Part15 C Section 15.247:

Test requirements: (d) In any 100 kHz bandwidth outside the frequency band in which the spread spectrum or digitally modulated intentional radiator is operating, the radio frequency power that is produced by the intentional radiator shall be at least 20 dB below that in the 100 kHz bandwidth within the band that contains the highest level of the desired power, based on either an RF conducted or a radiated measurement, provided the transmitter demonstrates compliance with the peak conducted power limits.

Test Procedure:

1. Remove the antenna from the EUT and then connect a low RF cable from the antenna port to the spectrum.
2. Set the spectrum analyzer: RBW = 100KHz, VBW \geq RBW (set 100KHz), Sweep = auto; Detector Function = Peak (Max. hold).

Test result:



Lowest Channel (channel 0)

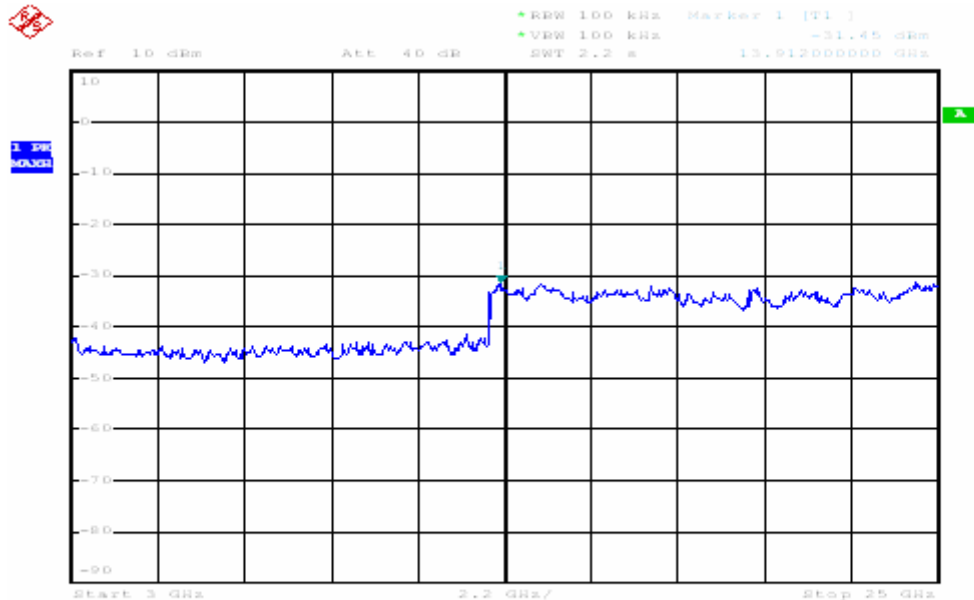
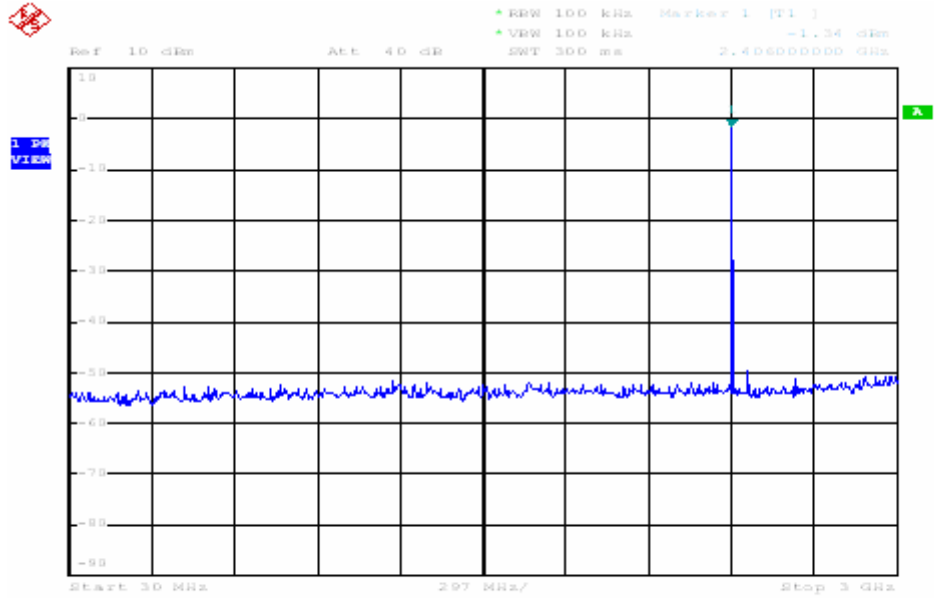



Medium Channel (channel 39)

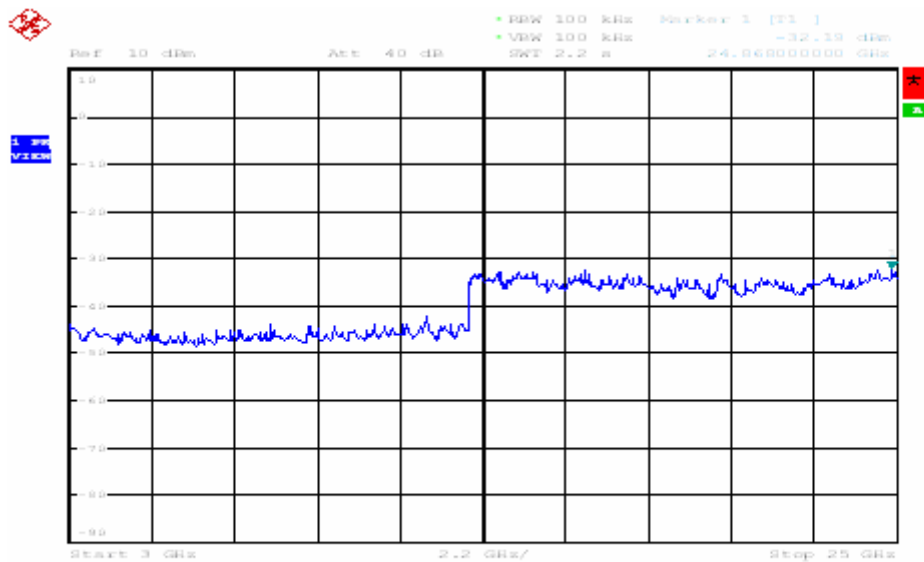
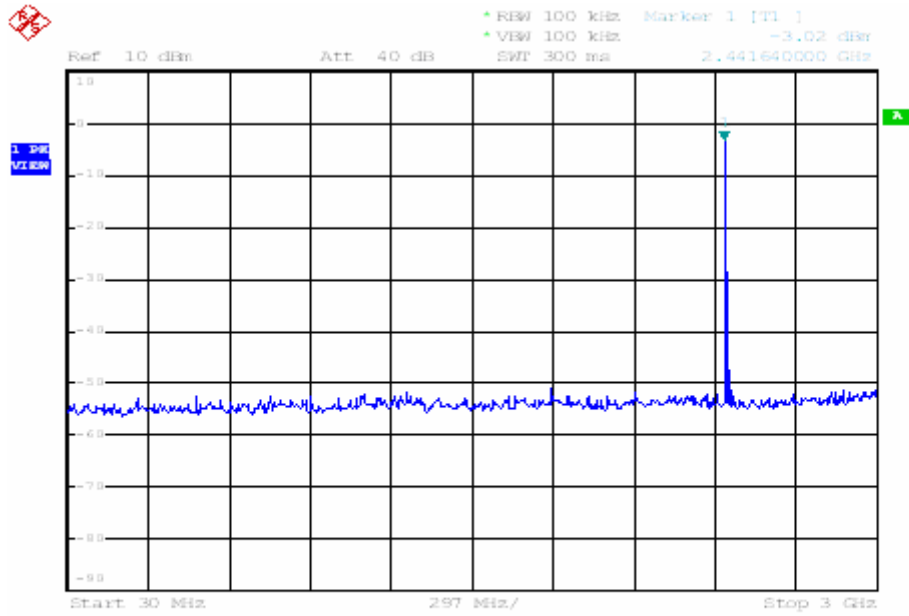



Highest Channel (channel 78)

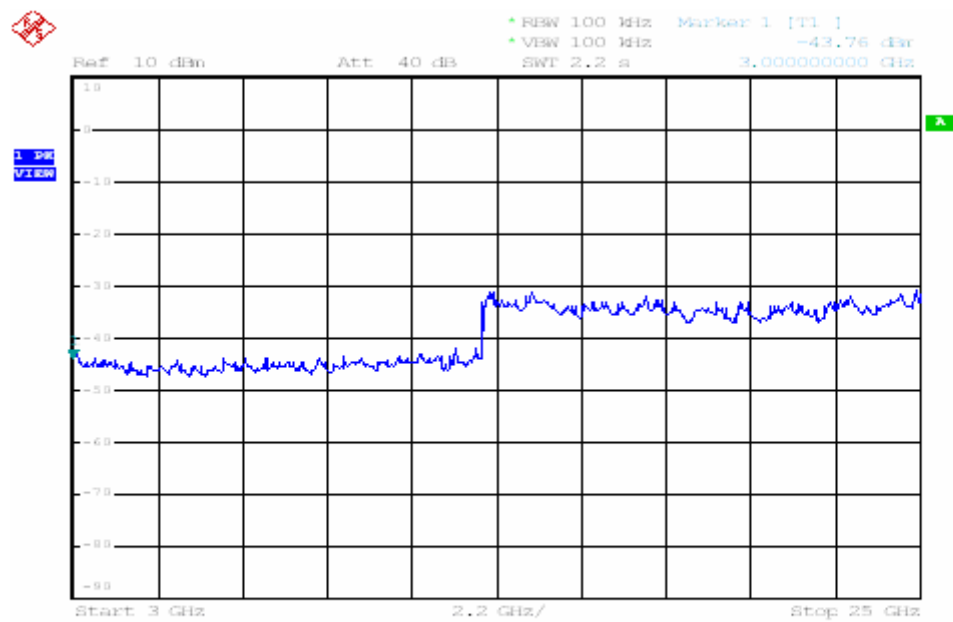
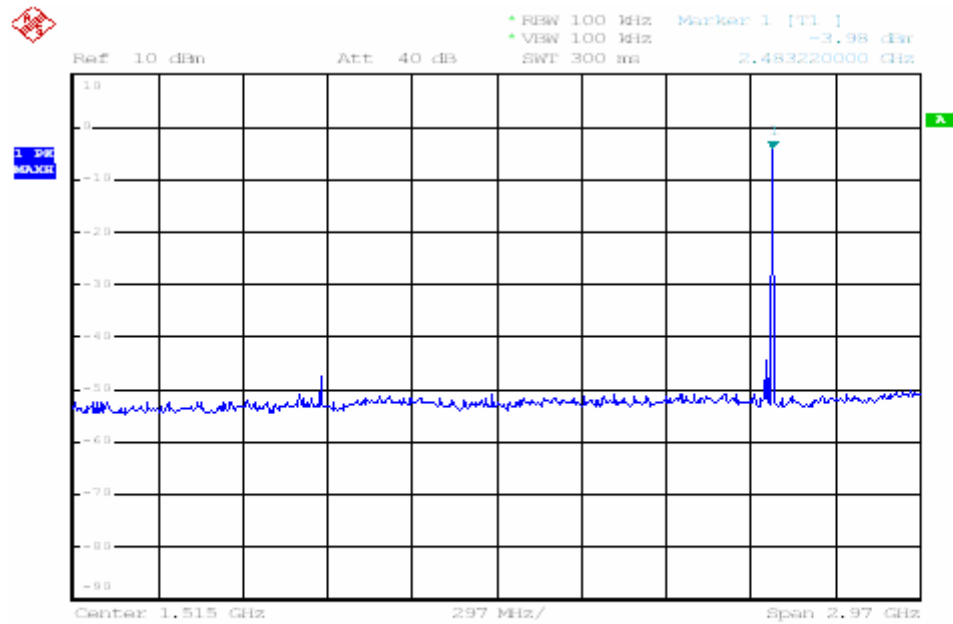

6.5 Radiated Spurious Emissions

Test Requirement: FCC 15.209 & FCC 15.109
 Test Method: ANSI C63.4 section 8 & 13
 Test Date: 15 Aug 2007
 Measurement Distance: 3m (Semi-Anechoic Chamber and OATS)
 Frequency range 30 MHz – 25GHz for transmitting mode.
 Test instrumentation resolution bandwidth 120 kHz (30 MHz - 1000 MHz)
 1 MHz (1000 MHz – 25GHz)
 Receive antenna scan height 1 m - 4 m, polarization Vertical / Horizontal

Limit: 40.0 dB μ V/m between 30MHz & 88MHz
 43.5 dB μ V/m between 88MHz & 216MHz
 46.0 dB μ V/m between 216MHz & 960MHz
 54.0 dB μ V/m above 960MHz

Test Configuration:

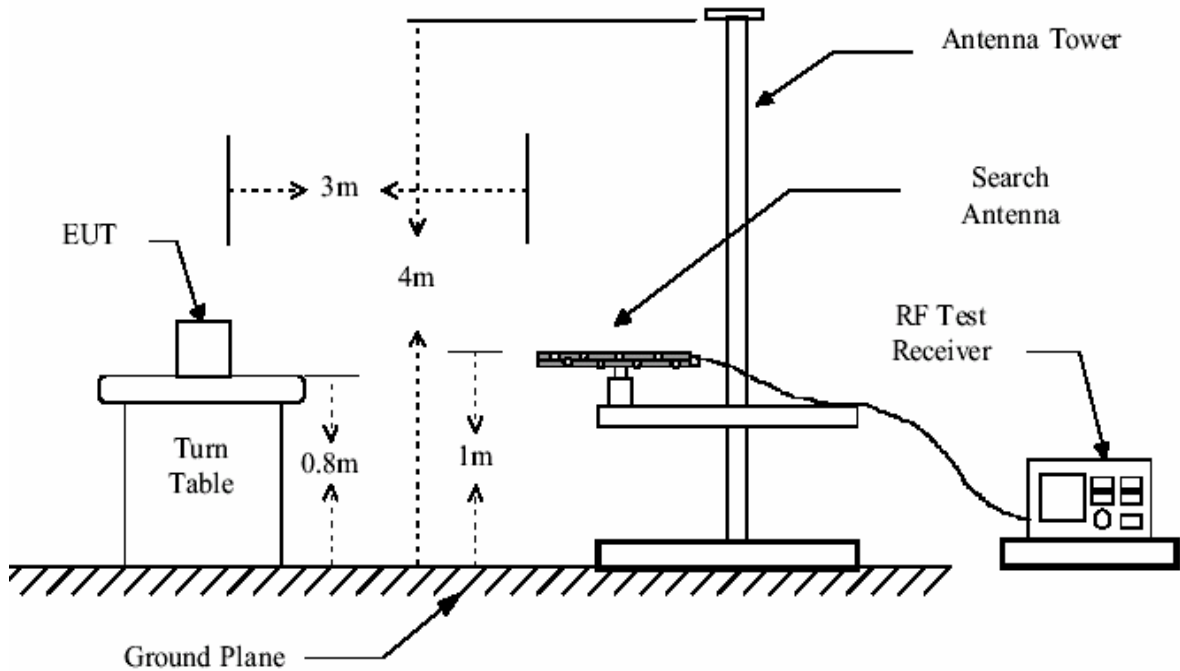

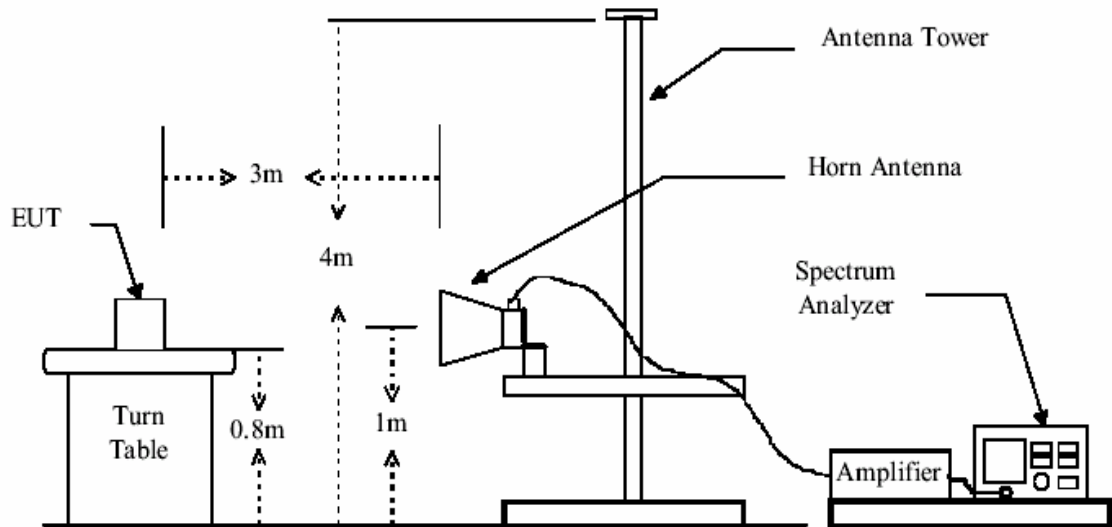

Test Procedure: The procedure used was ANSI Standard C63.4-2001. The receive was scanned from 30MHz to 25GHz. When an emission was found, the table was rotated to produce the maximum signal strength. An initial pre-scan was performed for in peak detection mode using the receiver. The EUT was measured for both the Horizontal and Vertical polarities and performed a pre-test three orthogonal planes. For intentional radiators, measurements of the variation of the input power or the radiated signal level of the fundamental frequency component of the emission, as appropriate, shall be performed with the supply voltage varied between 85% and 115% of the nominal rated supply voltage. The worst case emissions were reported.

The field strength is calculated by adding the Antenna Factor, Cable Factor & Peramplifier. The basic equation with a sample calculation is as follows:

$$\text{Final Test Level} = \text{Receiver Reading} + \text{Antenna Factor} + \text{Cable Factor} - \text{Peramplifier Factor}$$

The following test results were performed on the EUT



6.5.1 Harmonics Emissions

Test in Channel 0 in transmitting status:

Harmonics & Spurious Emissions

Peak Measurement

Test Frequency (GHz)	Measuring Level (dBuV/m)		Limits (dBuV/m)	Margin (dB)	
	Vertical	Horizontal		Vertical	Horizontal
2) 4.804	55.0	54.8	74.0	19.0	19.2
3) 7.206	56.0	55.5	74.0	18.0	18.5
4) 9.608	N/A	N/A	74.0	N/A	N/A
5) 12.010	N/A	N/A	74.0	N/A	N/A
6) 14.412	N/A	N/A	74.0	N/A	N/A
7) 16.814	N/A	N/A	74.0	N/A	N/A
8) 19.216	N/A	N/A	74.0	N/A	N/A
9) 21.618	N/A	N/A	74.0	N/A	N/A
10) 24.020	N/A	N/A	74.0	N/A	N/A

Average Measurement

2) 4.804	42.5	42.6	54.0	11.5	11.4
3) 7.206	43.2	43.5	54.0	10.8	10.5
4) 9.608	N/A	N/A	54.0	N/A	N/A
5) 12.010	N/A	N/A	54.0	N/A	N/A
6) 14.412	N/A	N/A	54.0	N/A	N/A
7) 16.814	N/A	N/A	54.0	N/A	N/A
8) 19.216	N/A	N/A	54.0	N/A	N/A
9) 21.618	N/A	N/A	54.0	N/A	N/A
10) 24.020	N/A	N/A	54.0	N/A	N/A

N/A: refer to remark 1).



Test in Channel 39 in transmitting status:

Harmonics & Spurious Emissions:

Peak Measurement

Test Frequency (GHz)	Measuring Level (dBuV/m)		Limits (dBuV/m)	Margin (dB)	
	Vertical	Horizontal		Vertical	Horizontal
11) 4.882	55.0	56.0	74.0	19.0	18.0
12) 7.323	64.0	65.0	74.0	10.0	9.0
13) 9.764	N/A	N/A	74.0	N/A	N/A
14) 12.205	N/A	N/A	74.0	N/A	N/A
15) 14.646	N/A	N/A	74.0	N/A	N/A
16) 17.087	N/A	N/A	74.0	N/A	N/A
17) 19.528	N/A	N/A	74.0	N/A	N/A
18) 21.969	N/A	N/A	74.0	N/A	N/A
19) 24.410	N/A	N/A	74.0	N/A	N/A

Average Measurement

11) 4.882	44.0	43.0	54.0	10.0	11.0
12) 7.323	43.0	41.0	54.0	11.0	13.0
13) 9.764	N/A	N/A	54.0	N/A	N/A
14) 12.205	N/A	N/A	54.0	N/A	N/A
15) 14.646	N/A	N/A	54.0	N/A	N/A
16) 17.087	N/A	N/A	54.0	N/A	N/A
17) 19.528	N/A	N/A	54.0	N/A	N/A
18) 21.969	N/A	N/A	54.0	N/A	N/A
19) 24.410	N/A	N/A	54.0	N/A	N/A

N/A: refer to remark 1).



Test in Channel 78 in transmitting status:

Harmonics & Spurious Emissions:

Peak Measurement

Test Frequency (GHz)	Measuring Level (dBuV/m)		Limits (dBuV/m)	Margin (dB)	
	Vertical	Horizontal		Vertical	Horizontal
20) 4.960	46.0	42.0	74.0	28.0	32.0
21) 7.440	53.0	50.8	74.0	21.0	23.2
22) 9.920	N/A	N/A	74.0	N/A	N/A
23) 12.400	N/A	N/A	74.0	N/A	N/A
24) 14.880	N/A	N/A	74.0	N/A	N/A
25) 17.360	N/A	N/A	74.0	N/A	N/A
26) 19.840	N/A	N/A	74.0	N/A	N/A
27) 22.320	N/A	N/A	74.0	N/A	N/A
28) 24.800	N/A	N/A	74.0	N/A	N/A

Average Measurement

20) 4.960	33.8	34.5	54.0	20.2	19.5
21) 7.440	30.5	32.4	54.0	23.5	21.6
22) 9.920	N/A	N/A	54.0	N/A	N/A
23) 12.400	N/A	N/A	54.0	N/A	N/A
24) 14.880	N/A	N/A	54.0	N/A	N/A
25) 17.360	N/A	N/A	54.0	N/A	N/A
26) 19.840	N/A	N/A	54.0	N/A	N/A
27) 22.320	N/A	N/A	54.0	N/A	N/A
28) 24.800	N/A	N/A	54.0	N/A	N/A

N/A: refer to remark 1).



Remark:

- 1). N/A: For this intentional radiator operates below 25 GHz, the spectrum shall be investigated to the tenth harmonic of the highest fundamental frequency. And above the third harmonic of this intentional radiator, the disturbance is very low. So the test result only displays to 3rd harmonic.

- 2). According to 15.249 (d) As shown in Section 15.35(b), for frequencies above 1000 MHz, the above field strength limits are based on average limits. However, the peak field strength of any emission shall not exceed the maximum permitted average limits specified above by more than 20 dB under any condition of modulation.

- 3). The test only perform the EUT in transmitting status since the test frequencies were over 1GHz only required transmitting status.

TEST RESULTS: The unit does meet the FCC requirements.



6.6 Radiated Emissions

Test Requirement: FCC Part15 Section 15.109
 Test Method: Based on ANSI C63.4
 Test Date: 14 August 2007
 Measurement Distance: 3m
 Limit: 40.0 dB μ V/m between 30MHz & 88MHz
 43.5 dB μ V/m between 88MHz & 216MHz
 46.0 dB μ V/m between 216MHz & 960MHz
 54.0 dB μ V/m above 960MHz
 Detector: Peak for pre-scan, 120kHz resolution bandwidth within 1GHz.
 Quasi-Peak if maximised peak within 6dB of limit

Test in Aux in function with AC/DC adapter.

The following measurement result were performed on the EUT:

Frequency (MHz)	Antenna Polarization	Emission Level (dB μ V/m)	Limit dB μ V/m)	Margin (dB)
49.400	Vertical	27.6	40.0	12.4
124.090	Vertical	30.4	43.5	13.1
170.650	Vertical	25.5	43.5	18.0
219.150	Vertical	30.6	46.0	15.4
393.750	Vertical	25.0	46.0	21.0
797.270	Vertical	31.9	46.0	14.1
71.71	Horizontal	28.1	40.0	11.9
124.090	Horizontal	25.6	43.5	18.0
164.830	Horizontal	32.1	43.5	11.4
225.940	Horizontal	30.7	46.0	15.3
309.360	Horizontal	26.4	46.0	19.6
389.870	Horizontal	25.6	46.0	20.4

Remark: No any other emission level margin less than 10dB and no emission distinct from 1GHz to 25GHz can be detected.

The field strength is calculated by adding the Antenna Factor, Cable Factor & Preamplifier.

The basic equation with a sample calculation is as follows:

Final Test Level =Receiver Reading + Antenna Factor + Cable Factor – Preamplifier Factor

TEST RESULTS: The unit does meet the FCC requirements



6.7 Band Edges Requirement

Test Requirement:	FCC Part 15 C
Test Method:	Based on FCC Part15 C Section 15.247: Operation within the band 2400 – 2483.5 MHz
Test Date:	14 Aug 2007
Requirements:	Section 15.247 (c) In any 100 kHz bandwidth outside the frequency band in which the spread spectrum intentional radiator is operating, the radio frequency power that is produced by the intentional radiator shall be at least 20 dB below that in the 100 kHz bandwidth within the band that contains the highest level of the desired power, based on either an RF conducted or a radiated measurement. Attenuation below the general limits specified in Section 15.209(a) is not required. In addition, radiated emissions which fall in the restricted bands, as defined in Section 15.205(a), must also comply with the radiated emission limits specified in Section 15.209(a) (see Section 15.205(c)).

6.7.1 100 kHz Bandwidth Outside the Frequency Band

Method of Measurement:	Set RBW of spectrum analyzer to 100 kHz and VBW of spectrum analyzer to 100 kHz with suitable frequency span including 100 kHz bandwidth from band edge. Detector = Peak Detector, Trace= Max Hold. The band edges was measured and recorded.
------------------------	--

The band edges was measured and recorded Result:

The Lower Edges: the value is -51.81dB that is attenuated more than 20dB.

The Upper Edges: the value is -52.79dB that is attenuated more than 20dB.

The unit does meet the FCC requirements.

The graph as below, represents the emissions take for this device.



1. For Lowest Channel: the fundamental frequency is **2.402G Hz**.

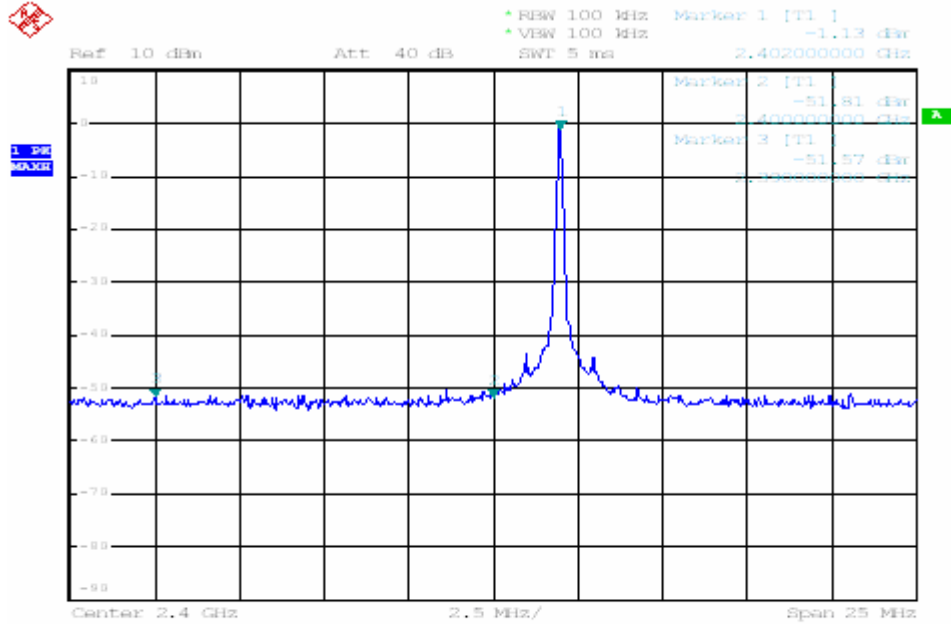

2. For Highest Channel: the fundamental frequency is **2.480GHz**.

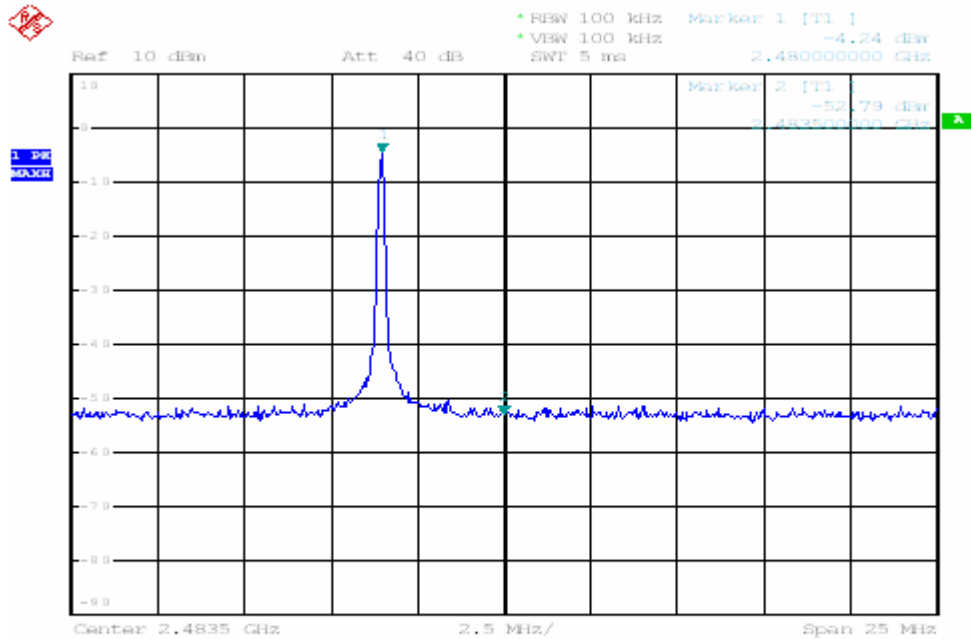

6.7.2 Radiated Emissions which fall in the restricted bands

Test Requirement:	Section 15.247 (c) In addition, radiated emissions which fall in the restricted bands, as defined in Section 15.205(a), must also comply with the radiated emission limits specified in Section 15.209(a) (see Section 15.205(c)).
Test Method:	Base on ANSI 63.4.
Test Date:	14 Aug 2007
Measurement Distance:	3m (Semi-Anechoic Chamber)
Limit:	40.0 dB μ V/m between 30MHz & 88MHz 43.5 dB μ V/m between 88MHz & 216MHz 46.0 dB μ V/m between 216MHz & 960MHz 54.0 dB μ V/m above 960MHz
Detector:	Peak for pre-scan , 120kHz resolution bandwidth within 1GHz, 1MHz resolution bandwidth above 1GHz

Test Configuration:

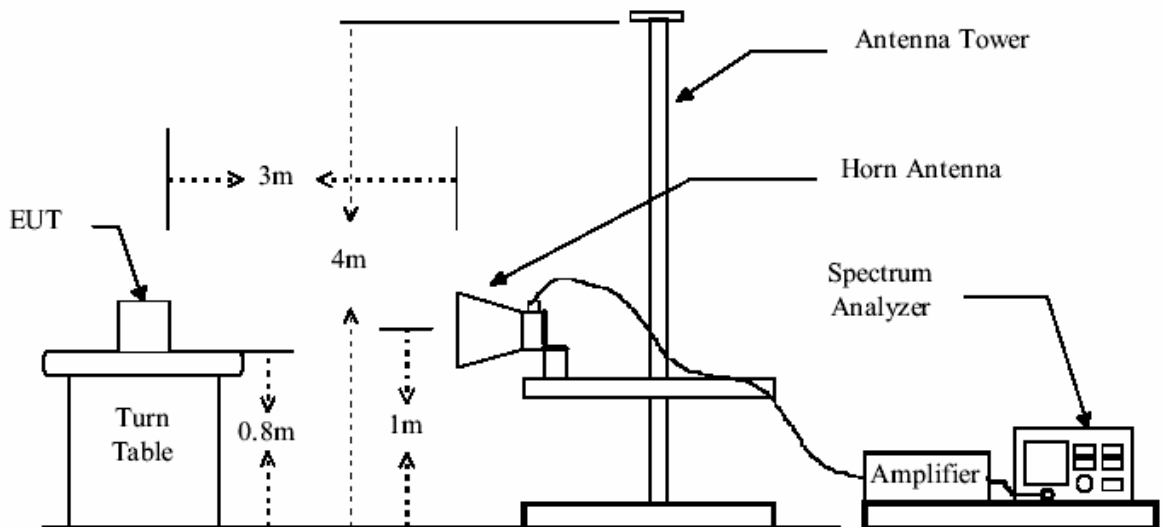



Test Procedure: The procedure used was ANSI Standard C63.4-2003. The receiver was scanned from 30MHz to 25GHz. When an emission was found, the table was rotated to produce the maximum signal strength. An initial pre-scan was performed for in peak detection mode using the receiver. The EUT was measured for both the Horizontal and Vertical polarities and performed a pre-test three orthogonal planes. For intentional radiators, measurements of the variation of the input power or the radiated signal level of the fundamental frequency component of the emission, as appropriate, shall be performed with the supply voltage varied between 85% and 115% of the nominal rated supply voltage. The worst case emissions were reported.

The field strength is calculated by adding the Antenna Factor, Cable Factor & Preamplifier. The basic equation with a sample calculation is as follows:

$$\text{Final Test Level} = \text{Receiver Reading} + \text{Antenna Factor} + \text{Cable Factor} - \text{Preamplifier Factor}$$

Test Result:

1. Channel 0 (2.402GHz)

Test Frequency (MHz)	Peak Level (dBuV/m)	Average Level (dBuV/m)	Peak Limit (dBuV/m)	Average Limit (dBuV/m)	Margin (dB)	
					Peak	AV
2390.000	44.0	37.2	74.0	54.0	30.0	16.8
2483.500	48.5	36.7	74.0	54.0	25.5	17.3

2. Channel 79 (2.480GHz)

Test Frequency (MHz)	Peak Level (dBuV/m)	Average Level (dBuV/m)	Peak Limit (dBuV/m)	Average Limit (dBuV/m)	Margin (dB)	
					Peak	AV
2390.000	48.7	37.2	74.0	54.0	25.3	16.8
2483.500	47.9	36.7	74.0	54.0	26.1	17.3

Remark: No any other emission which fall in restricted bands can be detected and be reported.

The test result graph as follows:

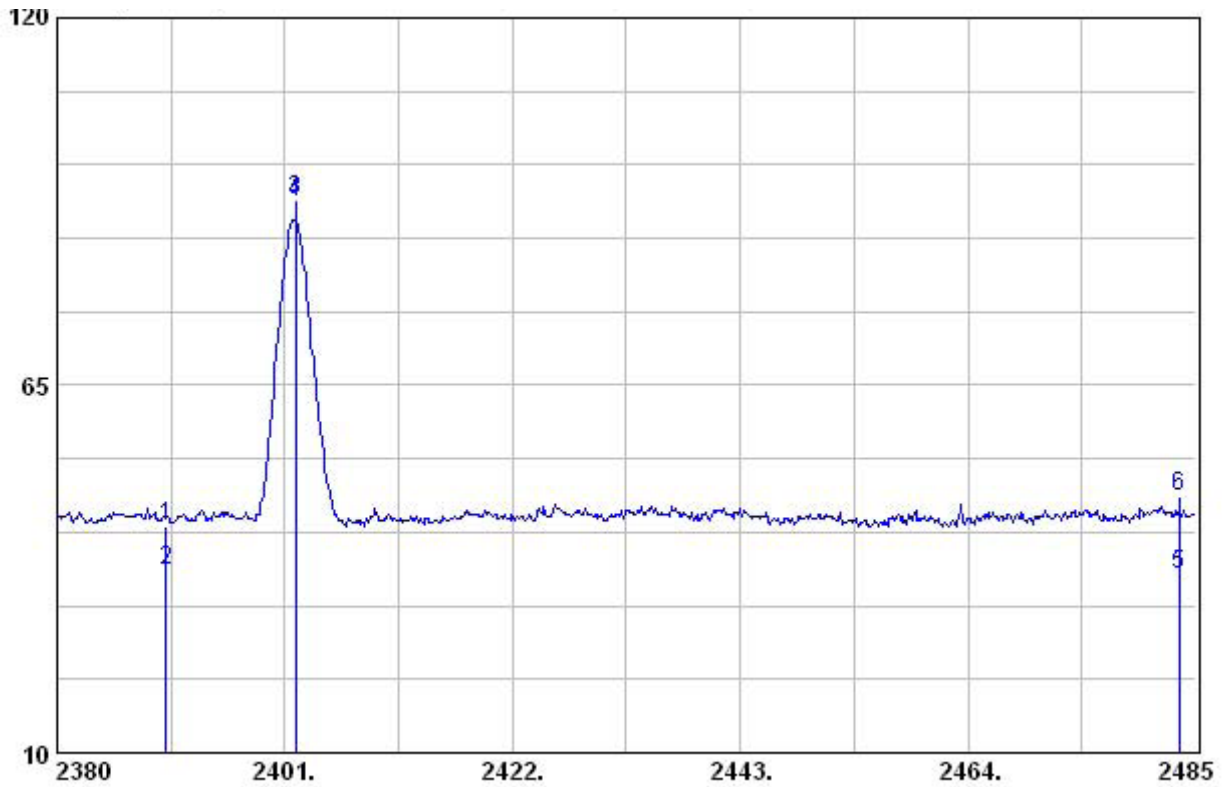

	Frequency (MHz)								Remark
	ReadAntenna	Cable	Preamp	Limit	Over				
1	2	3	4	5	6	7	8	9	
MHz	dBuV	dB/m	dB	dB	dBuV/m	dBuV/m	dB		
1	2390.000	45.50	28.55	4.60	34.77	43.88	-----	-----	Peak
2	2390.000	38.78	28.55	4.60	34.77	37.17	-----	-----	AVERAGE
3 @	2402.000	94.25	28.55	4.60	34.77	92.63	-----	-----	PEAK
4	2402.000	94.03	28.55	4.60	34.77	92.42	-----	-----	AVERAGE
5	2483.500	37.96	28.78	4.67	34.72	36.69	-----	-----	AVERAGE
6	2483.500	49.73	28.78	4.67	34.72	48.46	-----	-----	PEAK

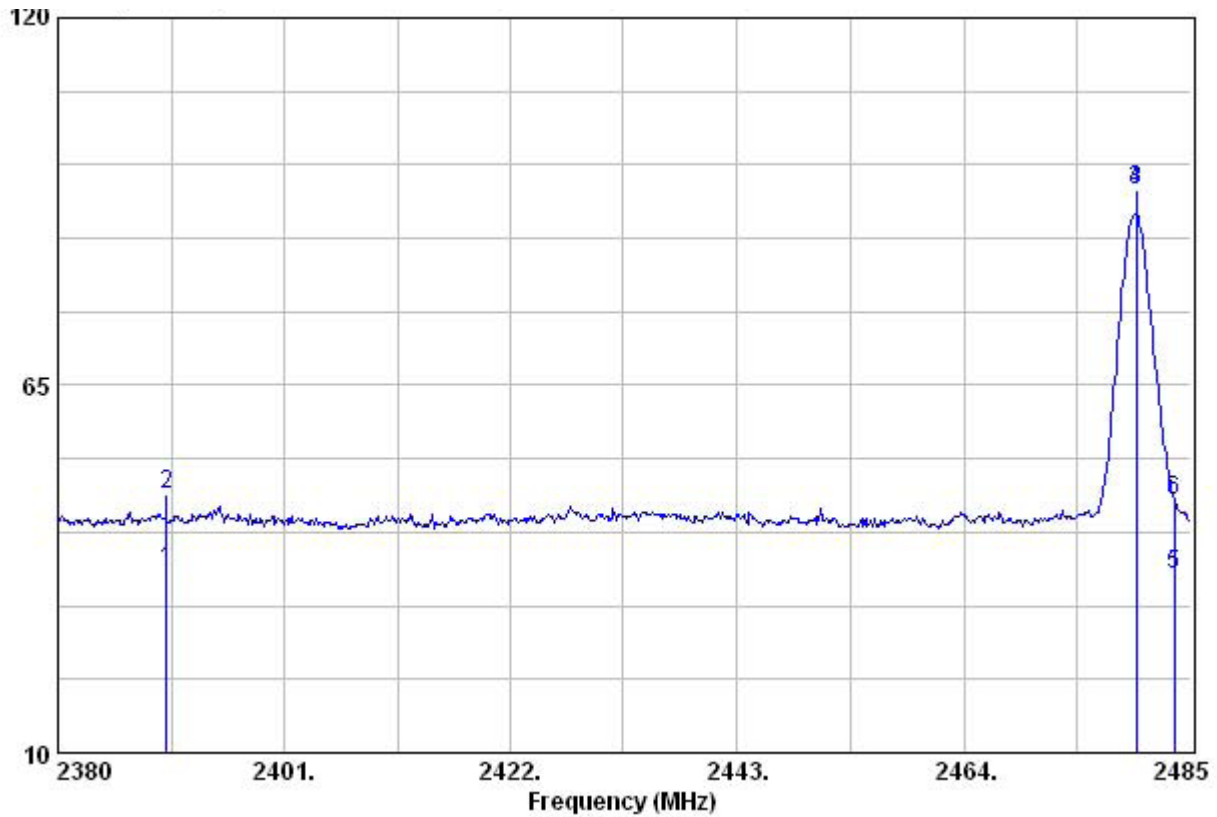

	Read	Antenna	Cable	Preamp	Limit	Over		
Freq	Level	Factor	Loss	Factor	Line	Limit	Remark	
MHz	dBuV	dB/m	dB	dB	dBuV/m	dBuV/m	dB	
1	2390.000	38.77	28.55	4.60	34.77	37.16	-----	AVERAGE
2	2390.000	50.26	28.55	4.60	34.77	48.65	-----	PEAK
3 @	2480.000	95.55	28.78	4.67	34.72	94.28	-----	AVERAGE
4 @	2480.000	95.60	28.78	4.67	34.72	94.33	-----	PEAK
5	2483.500	37.99	28.78	4.67	34.72	36.73	-----	AVERAGE
6	2483.500	49.16	28.78	4.67	34.72	47.89	-----	PEAK

The unit does meet the FCC requirements.



Section 15.205 Restricted bands of operation.

(a) Except as shown in paragraph (d) of this section, only spurious emissions are permitted in any of the frequency bands listed below:

MHz	MHz	MHz	GHz
0.090 - 0.110	16.42 - 16.423	399.9 - 410	4.5 - 5.15
¹ 0.495 - 0.505	16.69475 - 16.69525	608 - 614	5.35 - 5.46
2.1735 - 2.1905	16.80425 - 16.80475	960 - 1240	7.25 - 7.75
4.125 - 4.128	25.5 - 25.67	1300 - 1427	8.025 - 8.5
4.17725 - 4.17775	37.5 - 38.25	1435 - 1626.5	9.0 - 9.2
4.20725 - 4.20775	73 - 74.6	1645.5 - 1646.5	9.3 - 9.5
6.215 - 6.218	74.8 - 75.2	1660 - 1710	10.6 - 12.7
6.26775 - 6.26825	108 - 121.94	1718.8 - 1722.2	13.25 - 13.4
6.31175 - 6.31225	123 - 138	2200 - 2300	14.47 - 14.5
8.291 - 8.294	149.9 - 150.05	2310 - 2390	15.35 - 16.2
8.362 - 8.366	156.52475 - 156.52525	2483.5 - 2500	17.7 - 21.4
8.37625 - 8.38675	156.7 - 156.9	2655 - 2900	22.01 - 23.12
8.41425 - 8.41475	162.0125 - 167.17	3260 - 3267	23.6 - 24.0
12.29 - 12.293	167.72 - 173.2	3332 - 3339	31.2 - 31.8
12.51975 - 12.52025	240 - 285	3345.8 - 3358	36.43 - 36.5
12.57675 - 12.57725	322 - 335.4	3600 - 4400	(²)
13.36 - 13.41			

6.8 Hopping Channel Number

Test Requirement:	FCC Part15 C
Test Method:	Based on FCC Part15 C Section 15.247
Test Date:	15 Aug 2007
Requirements:	Regulation 15.247 (b) (1) For frequency hopping systems operating in the 2400-2483.5 MHz band employing at least 75 hopping channels.

Test Procedure:

1. Remove the antenna from the EUT and then connect a low RF cable from the antenna port to the spectrum.
2. Set the spectrum analyzer: RBW = 100KHz, VBW = 100KHz, Sweep = auto; Detector Function = Peak.
3. Set the spectrum analyzer: start frequency = 2400MHz, stop frequency = 2483.5MHz. Record the max. hold reading graph.

Test result: Total channels are 79 channels, channel 0 to channel 78.

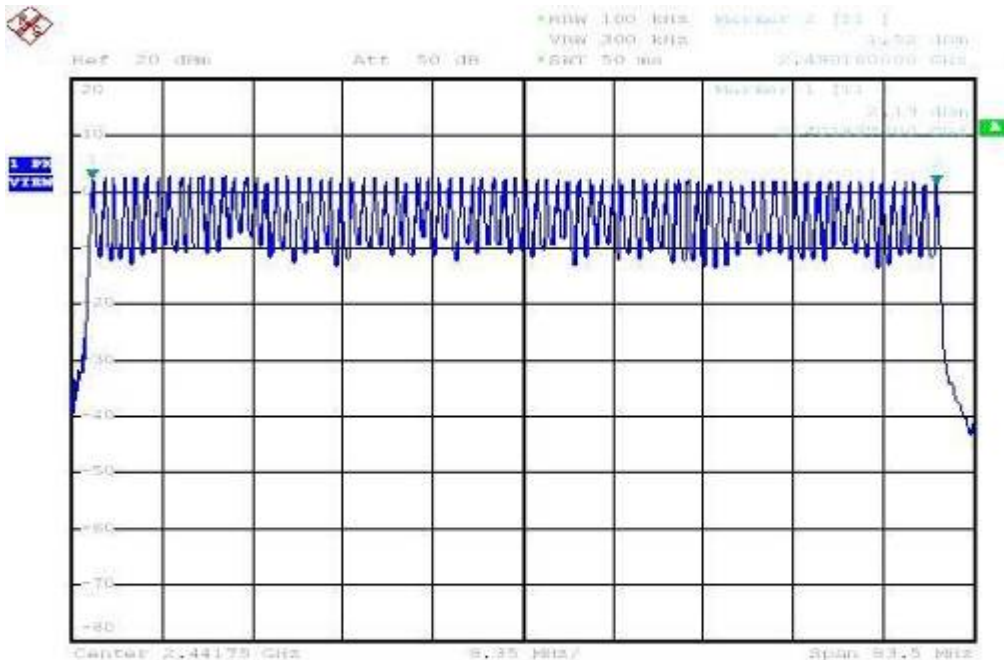

6.9 Occupied Bandwidth

Test Requirement: FCC Part 15 C
 Test Method: Based on FCC Part15 C Section 15.247:
 Test Date: 15 Aug 2007
 Test requirements: (a) Operation under the provisions of this Section is limited to frequency hopping and direct sequence spread spectrum intentional radiators that comply with the following provisions: (1) Frequency hopping systems shall have hopping channel carrier frequencies separated by a minimum of 25 kHz or the 20 dB bandwidth of the hopping channel, whichever is greater.

Test Procedure:

1. Remove the antenna from the EUT and then connect a low RF cable from the antenna port to the spectrum.
2. Set the spectrum analyzer: RBW >= 1% of the 20dB bandwidth (set 10KHz), VBW >= RBW (set 10KHz), Span = 3MHz, Sweep = auto; Detector Function = Peak (Max. hold).
3. Mark the peak frequency and -20dBm.

Test result:

Test Channel	20 dB bandwidth	PASS/FAIL
0	594KHz	Pass
39	588KHz	Pass
78	594KHz	Pass

The unit does meet the FCC requirements.

Please refer the graph as below: Lowest Channel (20 dB Bandwidth)

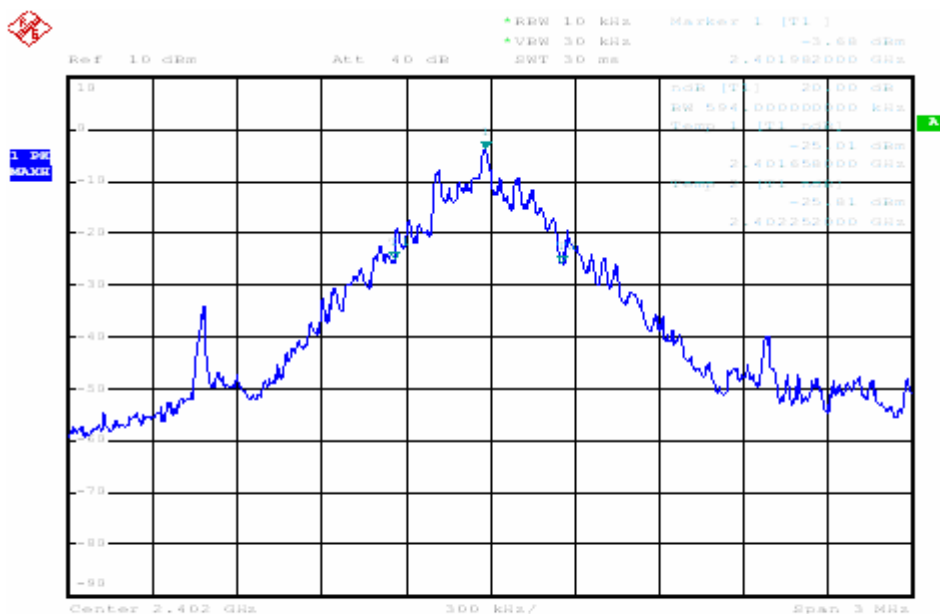



Medium Channel (20 dB Bandwidth)

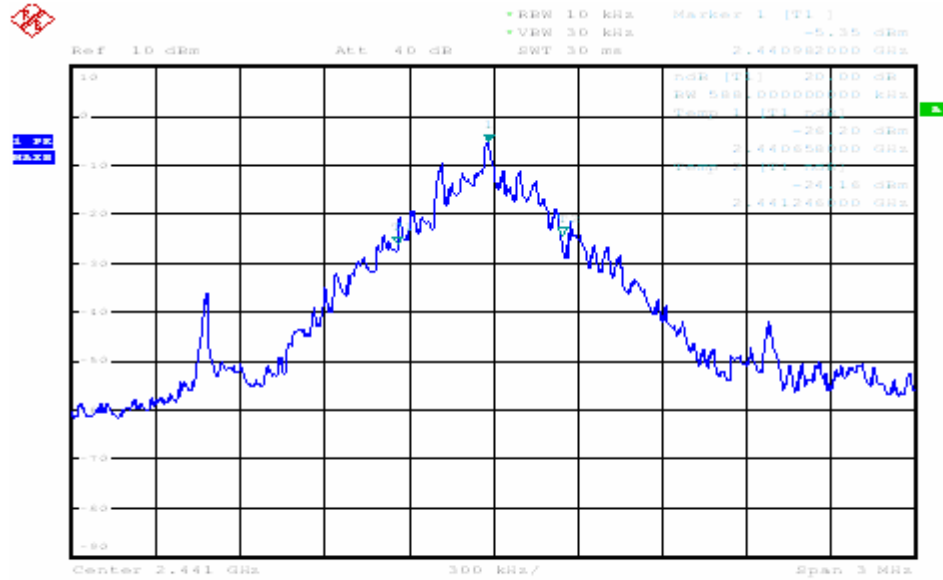

Highest Channel (20 dB Bandwidth)

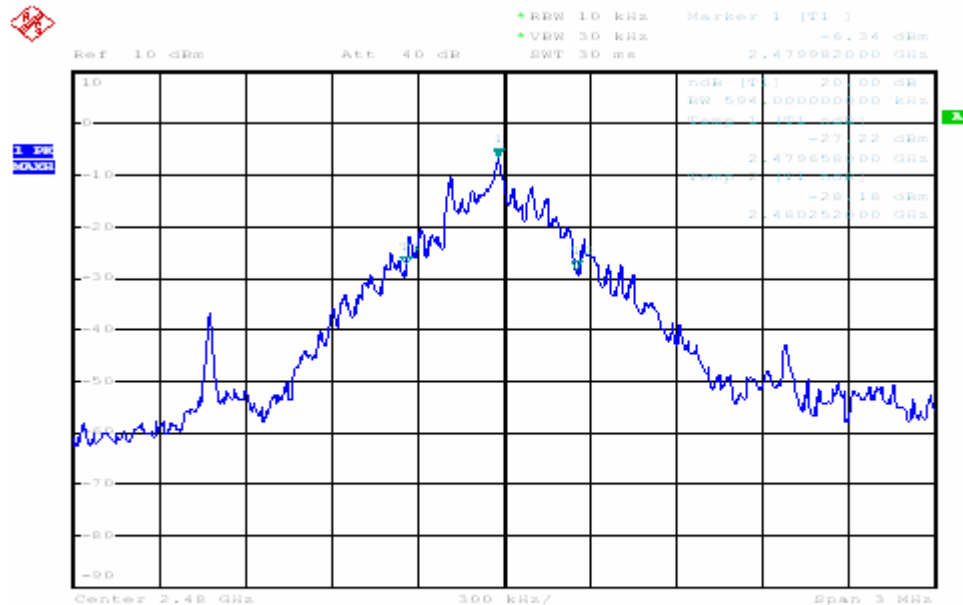

6.10 Carrier Frequencies Separated

Test Requirement: FCC Part 15 C
 Test Method: Based on FCC Part15 C Section 15.247:
 Test Date: 15 Aug 2007
 Test requirements: (a) Frequency hopping systems operating in the 2400-2483.5 MHz band may have hopping channel carrier frequencies that are separated by 25 kHz or two-thirds of the 20 dB bandwidth of the hopping channel, whichever is greater.

Test Procedure:

1. Remove the antenna from the EUT and then connect a low RF cable from the antenna port to the spectrum.
2. Set the spectrum analyzer: RBW >= 1% of the span (set 100KHz), VBW >= RBW (set 300KHz), Span = 10MHz, Sweep = auto; Detector Function = Peak (Max. hold).
3. Mark the peak frequency and -20dBm.

Test result:

Test Channel	Carrier Frequencies Separated	PASS/FAIL
Lower Channels (channel 0 and channel 1)	1.0MHz	Pass
Middle Channels (channel 39 and channel 40)	1.0MHz	Pass
Upper Channels (channel 77 and channel 78)	1.0MHz	Pass

1. Lower Channels: Carrier Frequencies Separated

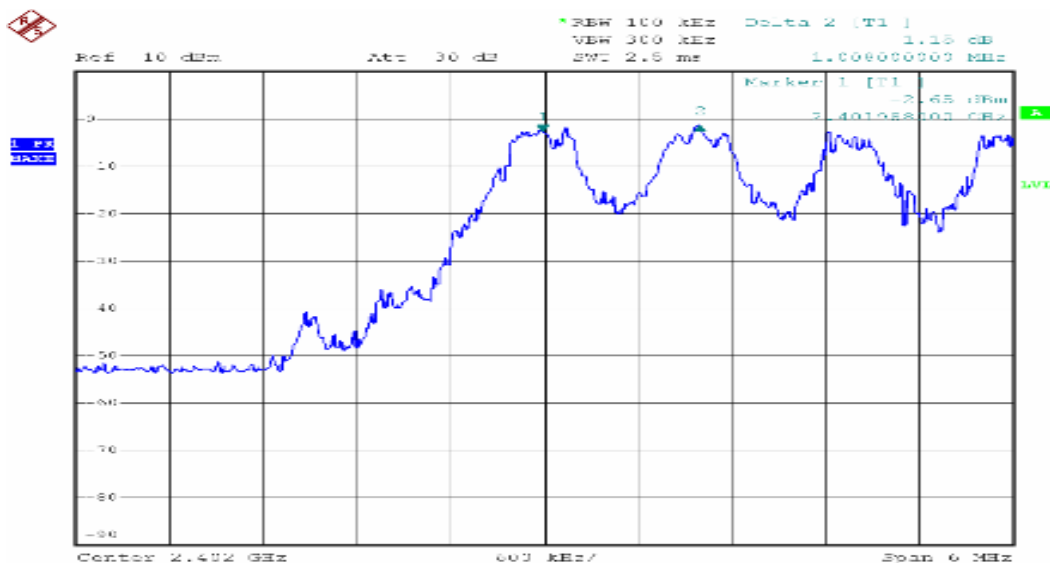

2. Middle Channels: **Carrier Frequencies Separated**

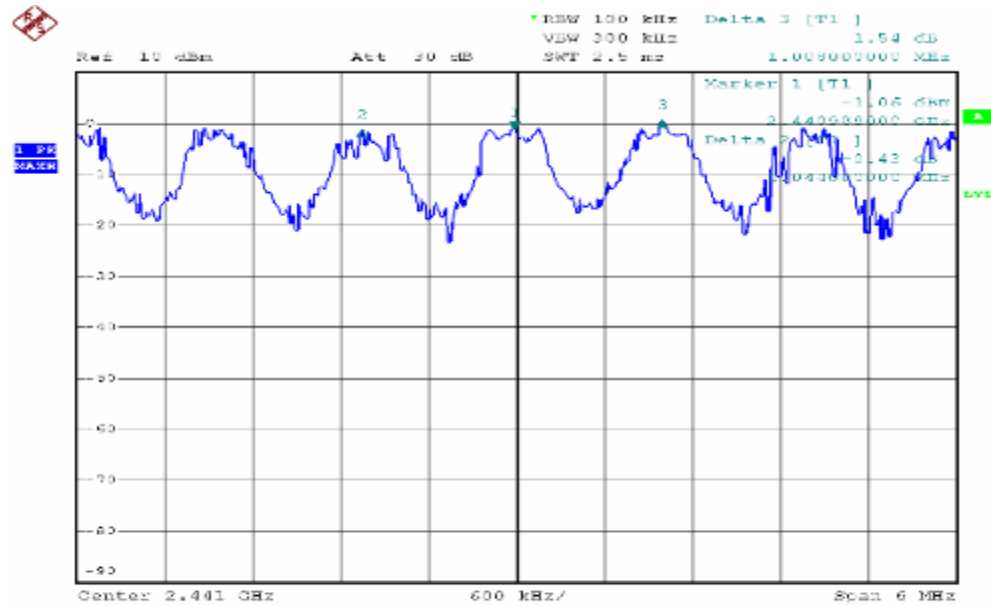

3. Higher Channels: **Carrier Frequencies Separated**

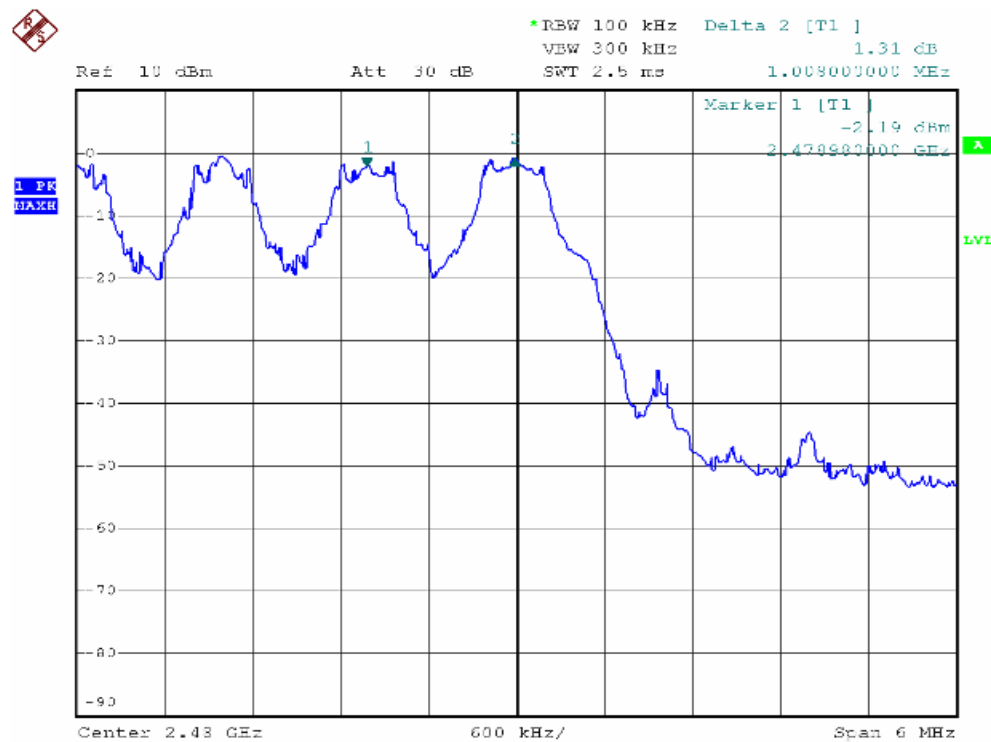



6.11 Dwell Time

Test Requirement: FCC Part 15 C
Test Method: Based on FCC Part15 C Section 15.247:
Test Date: 15 Aug 2007

Requirements: 15.247 a (1)(iii) Frequency hopping systems in the 2400-2483.5 MHz band shall use at least 15 non-overlapping channels. The average time of occupancy on any channel shall not be greater than 0.4 seconds within a period of 0.4 seconds multiplied by the number of hopping channels employed.

Test Procedure:

1. Remove the antenna from the EUT and then connect a low RF cable from the antenna port to the spectrum.
2. Set RBW of spectrum analyzer to 1MHz and VBW of spectrum analyzer to 1MHz , Set the test channel frequency span to 0.

Test Result:

The test period: $T = 0.4 \text{ Second/Channel} \times 79 \text{ Channel} = 31.6 \text{ s}$

1. Channel 0: 2.402GHz

DH1 time slot = $0.410 \text{ (ms)} \times (1600/(2 \times 79)) \times 31.6 = 131.200 \text{ ms}$

DH3 time slot = $1.660 \text{ (ms)} \times (1600/(4 \times 79)) \times 31.6 = 265.600 \text{ ms}$

DH5 time slot = $2.890 \text{ (ms)} \times (1600/(6 \times 79)) \times 31.6 = 308.267 \text{ ms}$

2. Channel 39: 2.441GHz

DH1 time slot = $0.400 \text{ (ms)} \times (1600/(2 \times 79)) \times 31.6 = 128.000 \text{ ms}$

DH3 time slot = $1.660 \text{ (ms)} \times (1600/(4 \times 79)) \times 31.6 = 265.600 \text{ ms}$

DH5 time slot = $2.900 \text{ (ms)} \times (1600/(6 \times 79)) \times 31.6 = 309.333 \text{ ms}$

3. Channel 78: 2.4835GHz

DH1 time slot = $0.410 \text{ (ms)} \times (1600/(2 \times 79)) \times 31.6 = 131.200 \text{ ms}$

DH3 time slot = $1.660 \text{ (ms)} \times (1600/(4 \times 79)) \times 31.6 = 265.600 \text{ ms}$

DH5 time slot = $2.890 \text{ (ms)} \times (1600/(6 \times 79)) \times 31.6 = 308.267 \text{ ms}$

The results are not be greater than 0.4 seconds.

The unit does meet the FCC requirements.

Please refer the graph as below:

1. Lowest channel (2.402 GHz):

(1). DH1

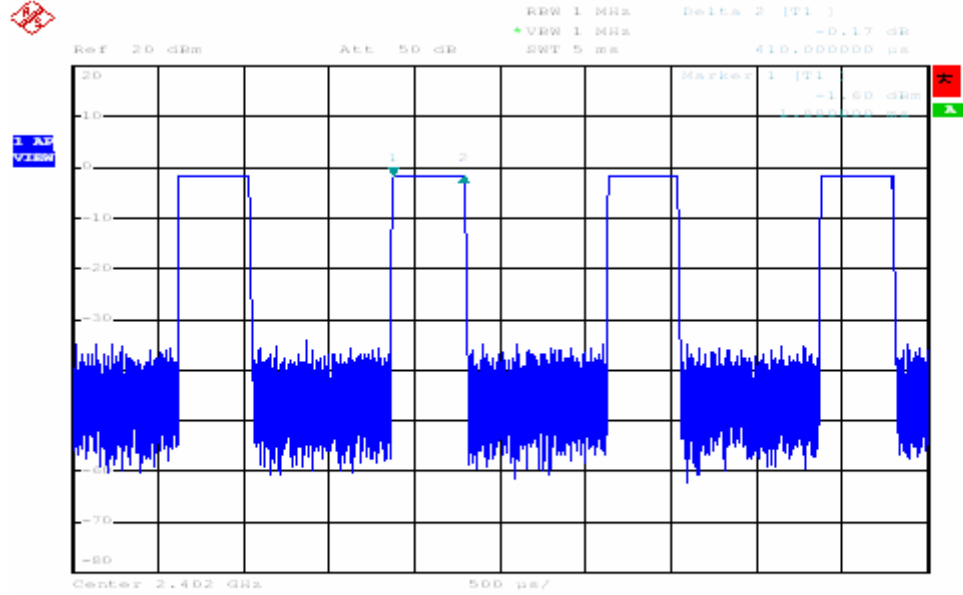

(2) DH3:

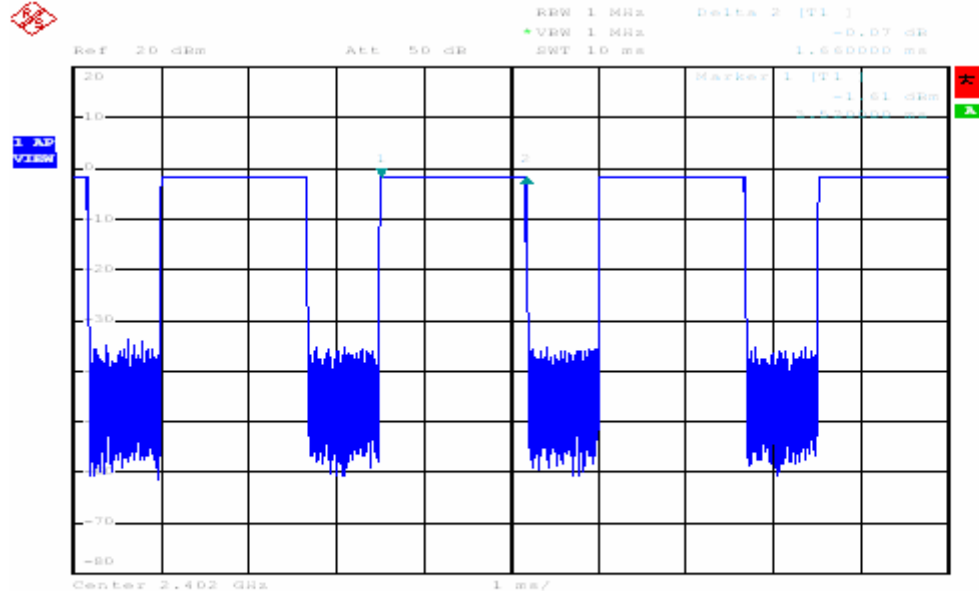

1. Lowest channel (2.402 GHz):

(3). DH5:

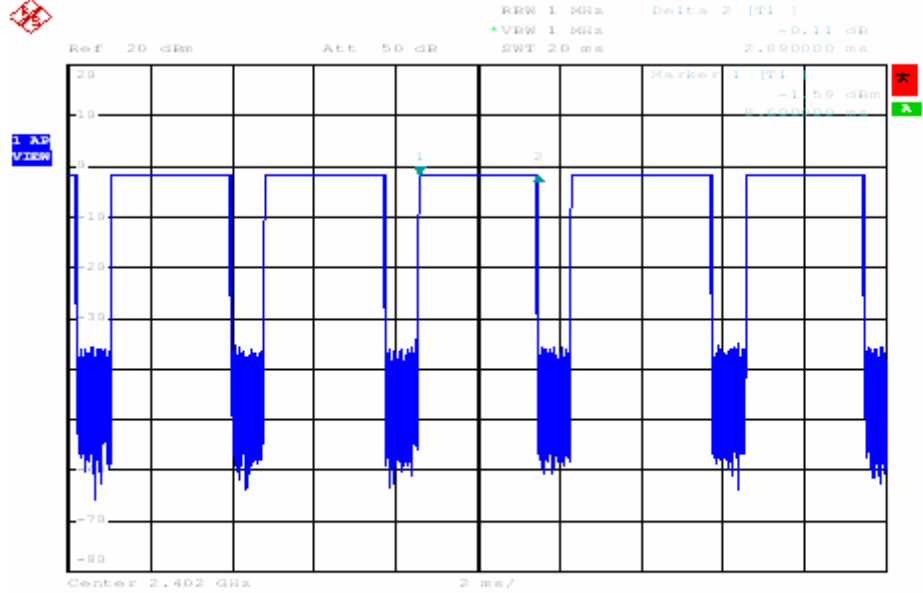

2. Middle Channel (2.441GHz)

(1) DH1

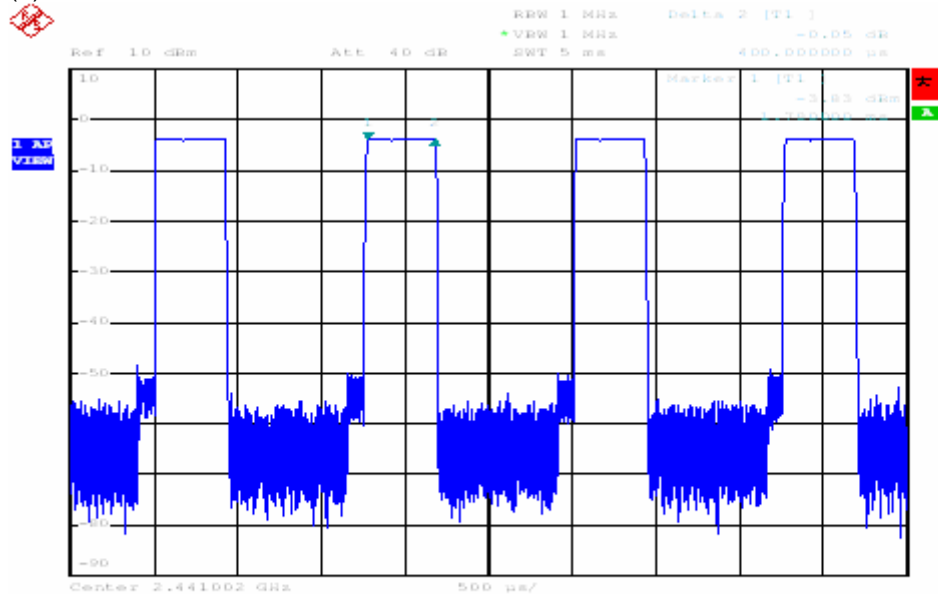



2. Middle Channel (2.441GHz)

(2) DH3

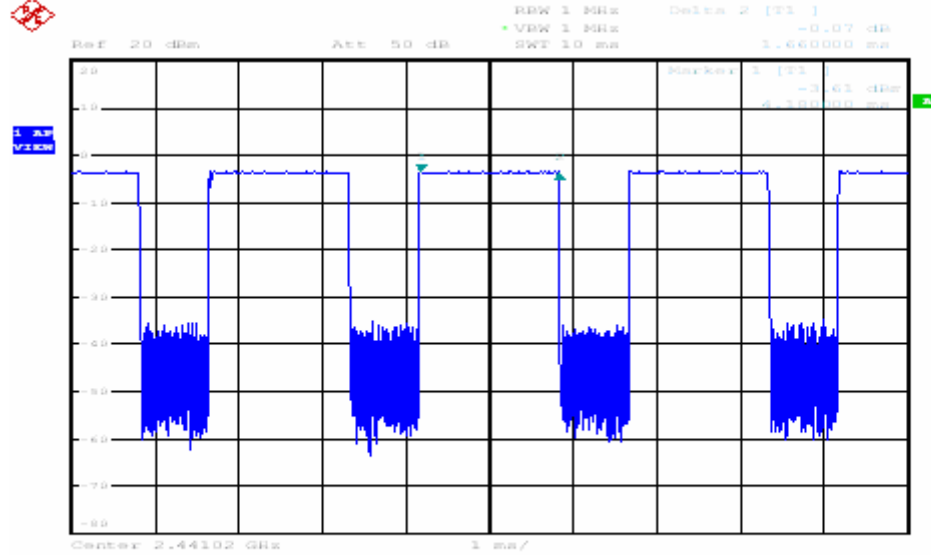

(3) DH5

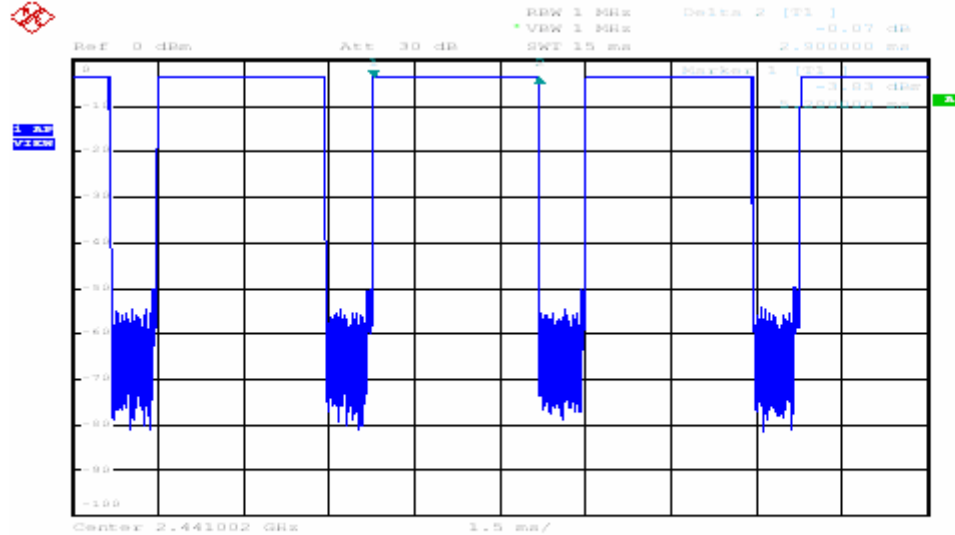

3. Highest channel (2.480GHz)

(1). DH1

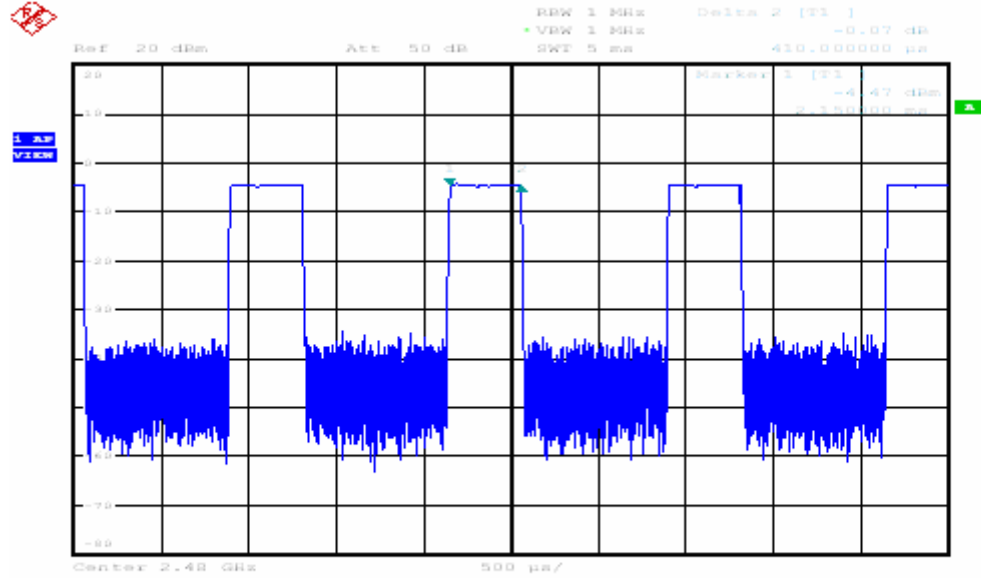

(2). DH3

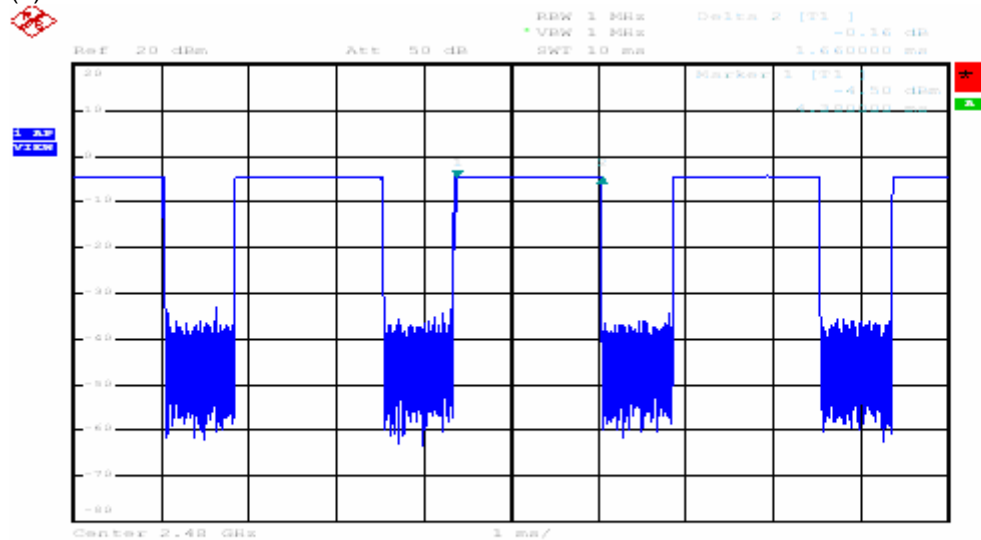

3. Highest channel (2.480GHz)

(3). DH5

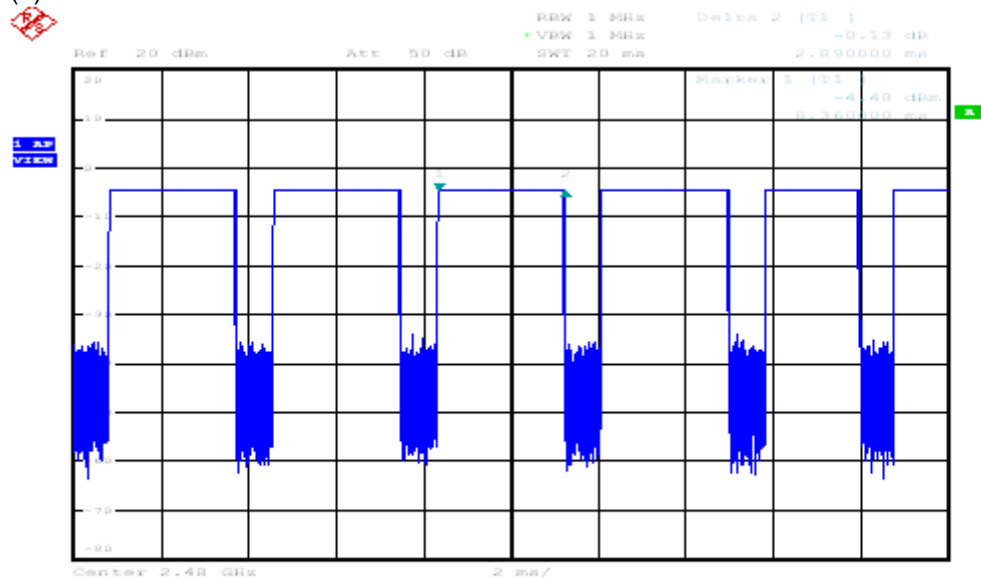



6.12 Antenna Requirement

6.12.1 Standard Applicable

For intentional device, according to 15.203, an intentional radiator shall be designed to ensure that no antenna other than that furnished by the responsible party shall be used with the device.

Systems operating in the 2400-2483.5 MHz band that are used exclusively for fixed, point-to-point operations may employ transmitting antennas with directional gain greater than 6 dBi provided the maximum conducted output power of the intentional radiator is reduced by 1 dB for every 3dB that the directional gain of the antenna exceeds 6 dBi.

6.12.2 Antenna Construction

The antenna is integral type gain 0.2dBi by antenna manufacturer described.