



RADIO TEST REPORT

Test Report No. : 32JE0006-HO-01-B

Applicant : **Hosiden Corporation**
Type of Equipment : **Bluetooth module**
Model No. : **ARC0503**
FCC ID : **VIYARC0503**
Test regulation : **FCC Part 15 Subpart C: 2012**
Test Result : **Complied**

1. This test report shall not be reproduced in full or partial, without the written approval of UL Japan, Inc.
2. The results in this report apply only to the sample tested.
3. This sample tested is in compliance with the above regulation.
4. The test results in this report are traceable to the national or international standards.
5. This test report must not be used by the customer to claim product certification, approval, or endorsement by NVLAP, NIST, or any agency of the Federal Government.

Date of test: May 28 to June 21, 2012

Representative test engineer:

Motoya Imura
Engineer of WiSE Japan,
UL Verification Service

Approved by:

Norihisa Hashimoto
Leader of WiSE Japan,
UL Verification Service



NVLAP LAB CODE: 200572-0

This laboratory is accredited by the NVLAP LAB CODE 200572-0, U.S.A. The tests reported herein have been performed in accordance with its terms of accreditation. *As for the range of Accreditation in NVLAP, you may refer to the WEB address, <http://www.ul.com/japan/jpn/pages/services/emc/about/mark1/index.jsp#nvlap>

UL Japan, Inc.

Head Office EMC Lab.

4383-326 Asama-cho, Ise-shi, Mie-ken 516-0021 JAPAN

Telephone : +81 596 24 8116

Facsimile : +81 596 24 8124

13-EM-F0429

CONTENTS	PAGE
SECTION 1: Customer information.....	3
SECTION 2: Equipment under test (E.U.T.).....	3
SECTION 3: Test specification, procedures & results.....	4
SECTION 4: Operation of E.U.T. during testing.....	7
SECTION 5: Radiated Spurious Emission	9
SECTION 6: Antenna Terminal Conducted Tests.....	10
APPENDIX 1: Data of EMI test.....	11
20dB Bandwidth and Carrier Frequency Separation.....	11
Number of Hopping Frequency	13
Dwell time.....	15
Maximum Peak Output Power.....	17
Radiated Spurious Emission	18
Conducted Spurious Emission	21
Conducted Emission Band Edge compliance	27
99%Occupied Bandwidth	28
APPENDIX 2: Test instruments	30
APPENDIX 3: Photographs of test setup.....	31
Radiated Spurious Emission	31
Worst Case Position (Horizontal: X-axis/ Vertical:Z-axis)	32

SECTION 1: Customer information

Company Name : Hosiden Corporation
Address : 1-4-33, Kitakyuhoji, Yao, Osaka, 5810071, Japan
Telephone Number : +81-72-924-1195
Facsimile Number : +81-72-993-0724
Contact Person : Keiji Mine

SECTION 2: Equipment under test (E.U.T.)

2.1 Identification of E.U.T.

Type of Equipment : Bluetooth module
Model No. : ARC0503
Serial No. : Refer to Section 4, Clause 4.2
Rating : DC 2.0 to DC 3.0V
Receipt Date of Sample : May 18, 2012
Country of Mass-production : China
Condition of EUT : Production prototype
(Not for Sale: This sample is equivalent to mass-produced items.)
Modification of EUT : No Modification by the test lab

2.2 Product Description

General Specification

Clock frequency(ies) in the system : 24MHz

Radio Specification

[Bluetooth (Ver. 3.0 without EDR function)]

Radio Type : Transceiver
Frequency of Operation : 2402-2480MHz
Modulation : FHSS, GFSK
Power Supply (radio part input) : DC 1.2V
Antenna type : PWB pattern antenna
Antenna Gain : -3dBi

UL Japan, Inc.

Head Office EMC Lab.

4383-326 Asama-cho, Ise-shi, Mie-ken 516-0021 JAPAN

Telephone : +81 596 24 8116

Facsimile : +81 596 24 8124

SECTION 3: Test specification, procedures & results

3.1 Test Specification

Test Specification : FCC Part 15 Subpart C: 2012, final revised on May 17, 2012 and effective June 18, 2012

Title : FCC 47CFR Part15 Radio Frequency Device Subpart C Intentional Radiators
Section 15.207 Conducted limits
Section 15.247 Operation within the bands 902-928MHz,
2400-2483.5MHz, and 5725-5850MHz

*The revision on May 17, 2012 does not affect the test specification applied to the EUT.

* The EUT complies with FCC Part 15 Subpart B: 2011, final revised on May 17, 2012.

3.2 Procedures and results

Item	Test Procedure	Specification	Worst Margin	Results	Remarks
Conducted Emission	FCC: ANSI C63.4:2003 7. AC powerline conducted emission measurements IC: RSS-Gen 7.2.4	FCC: Section 15.207 ----- IC: RSS-Gen 7.2.4	N/A *1)	N/A	-
Carrier Frequency Separation	FCC: FCC Public Notice DA 00-705 ----- IC: -	FCC: Section15.247(a)(1) ----- IC: RSS-210 A8.1 (b)	See data.	Complied	Conducted
20dB Bandwidth	FCC: FCC Public Notice DA 00-705 ----- IC: -	FCC: Section15.247(a)(1) ----- IC: RSS-210 A8.1 (a)		Complied	Conducted
Number of Hopping Frequency	FCC: FCC Public Notice DA 00-705 ----- IC: -	FCC: Section15.247(a)(1)(iii) ----- IC: RSS-210 A8.1 (d)		Complied	Conducted
Dwell time	FCC: FCC Public Notice DA 00-705 ----- IC: -	FCC: Section15.247(a)(1)(iii) ----- IC: RSS-210 A8.1 (d)		Complied	Conducted
Maximum Peak Output Power	FCC: FCC Public Notice DA 00-705 ----- IC: RSS-Gen 4.8	FCC: Section15.247(b)(1) ----- IC: RSS-210 A8.4 (2)		Complied	Conducted
Spurious Emission & Band Edge Compliance	FCC: FCC Public Notice DA 00-705 ----- IC: RSS-Gen 4.9	FCC: Section15.247(d) ----- IC: RSS-210 A8.5 RSS-Gen 6 and 7.2.3		7.7dB 4960.000MHz, AV, Vertical	Complied

Note: UL Japan, Inc.'s EMI Work Procedures No. 13-EM-W0420 and 13-EM-W0422.

*1) The test is not applicable since the EUT is not the device that is designed to be connected to the public utility (AC) power line.

* In case any questions arise about test procedure, ANSI C63.4: 2003 is also referred.

FCC 15.31 (e)

This EUT provides stable voltage (DC1.2V) constantly to RF Module regardless of input voltage. Therefore, this EUT complies with the requirement.

FCC Part 15.203/212 Antenna requirement

It is impossible for end users to replace the antenna, because the antenna is mounted inside of the EUT. Therefore, the equipment complies with the antenna requirement of Section 15.203.

3.3 Addition to standard

Item	Test Procedure	Specification	Worst margin	Results	Remarks
99% Occupied Bandwidth	IC: RSS-Gen 4.6.1	IC: RSS-Gen 4.6.1	N/A	-	Conducted

Other than above, no addition, exclusion nor deviation has been made from the standard.

3.4 Uncertainty

EMI

The following uncertainties have been calculated to provide a confidence level of 95% using a coverage factor k=2.

Test room (semi-anechoic chamber)	Radiated emission						
	(3m*)(+dB)				(1m*)(+dB)		(0.5m*)(+dB)
	9kHz -30MHz	30MHz -300MHz	300MHz -1GHz	1GHz -10GHz	10GHz -18GHz	18GHz -26.5GHz	26.5GHz -40GHz
No.1	4.2dB	5.0dB	5.1dB	4.7dB	5.7dB	4.4dB	4.3dB
No.2	4.1dB	5.2dB	5.1dB	4.8dB	5.6dB	4.3dB	4.2dB
No.3	4.5dB	5.0dB	5.2dB	4.8dB	5.6dB	4.5dB	4.2dB
No.4	4.7dB	5.2dB	5.2dB	4.8dB	5.6dB	5.1dB	4.2dB

*3m/1m/0.5m = Measurement distance

Power meter (+dB)	
Below 1GHz	Above 1GHz
1.0dB	1.0dB

Antenna terminal conducted emission and Power density (+dB)			Antenna terminal conducted emission (+dB)		Channel power (+dB)
Below 1GHz	1GHz-3GHz	3GHz-18GHz	18GHz-26.5GHz	26.5GHz-40GHz	
1.0dB	1.1dB	2.7dB	3.2dB	3.3dB	1.5dB

Radiated emission test(3m)

The data listed in this test report has enough margin, more than the site margin.

UL Japan, Inc.

Head Office EMC Lab.

4383-326 Asama-cho, Ise-shi, Mie-ken 516-0021 JAPAN

Telephone : +81 596 24 8116

Facsimile : +81 596 24 8124

3.5 Test Location

UL Japan, Inc. Head Office EMC Lab. *NVLAP Lab. code: 200572-0
4383-326 Asama-cho, Ise-shi, Mie-ken 516-0021 JAPAN
Telephone : +81 596 24 8116 Facsimile : +81 596 24 8124

	FCC Registration Number	IC Registration Number	Width x Depth x Height (m)	Size of reference ground plane (m) / horizontal conducting plane	Other rooms
No.1 semi-anechoic chamber	313583	2973C-1	19.2 x 11.2 x 7.7m	7.0 x 6.0m	No.1 Power source room
No.2 semi-anechoic chamber	655103	2973C-2	7.5 x 5.8 x 5.2m	4.0 x 4.0m	-
No.3 semi-anechoic chamber	148738	2973C-3	12.0 x 8.5 x 5.9m	6.8 x 5.75m	No.3 Preparation room
No.3 shielded room	-	-	4.0 x 6.0 x 2.7m	N/A	-
No.4 semi-anechoic chamber	134570	2973C-4	12.0 x 8.5 x 5.9m	6.8 x 5.75m	No.4 Preparation room
No.4 shielded room	-	-	4.0 x 6.0 x 2.7m	N/A	-
No.5 semi-anechoic chamber	-	-	6.0 x 6.0 x 3.9m	6.0 x 6.0m	-
No.6 shielded room	-	-	4.0 x 4.5 x 2.7m	4.75 x 5.4 m	-
No.6 measurement room	-	-	4.75 x 5.4 x 3.0m	4.75 x 4.15 m	-
No.7 shielded room	-	-	4.7 x 7.5 x 2.7m	4.7 x 7.5m	-
No.8 measurement room	-	-	3.1 x 5.0 x 2.7m	N/A	-
No.9 measurement room	-	-	8.0 x 4.5 x 2.8m	2.0 x 2.0m	-
No.10 measurement room	-	-	2.6 x 2.8 x 2.5m	2.4 x 2.4m	-
No.11 measurement room	-	-	3.1 x 3.4 x 3.0m	2.4 x 3.4m	-

* Size of vertical conducting plane (for Conducted Emission test) : 2.0 x 2.0m for No.1, No.2, No.3, and No.4 semi-anechoic chambers and No.3 and No.4 shielded rooms.

3.6 Data of EMI, Test instruments, and Test set up

Refer to APPENDIX.

SECTION 4: Operation of E.U.T. during testing

4.1 Operating Mode(s)

Bluetooth (BT): Transmitting (Tx), Payload: PRBS9

Details of Operating Mode(s)

Test Item	Mode	Tested frequency
Conducted Emission, Spurious Emission (Conducted/Radiated)	Tx (Hopping off) DH5	2402MHz 2441MHz 2480MHz
Carrier Frequency Separation	Tx (Hopping on) DH5	2402MHz 2441MHz 2480MHz
20dB Bandwidth	Tx (Hopping off) DH5	2402MHz 2441MHz 2480MHz
Number of Hopping Frequency	Tx (Hopping on) DH5	-
Dwell time	Tx (Hopping on), -DH1, DH3, DH5	-
Maximum Peak Output Power	Tx (Hopping off) DH5	2402MHz 2441MHz 2480MHz
Band Edge Compliance (Conducted)	Tx DH5 -Hopping on -Hopping off	2402MHz 2480MHz
99% Occupied Bandwidth	Tx DH5 -Hopping on -Hopping off	2402MHz 2441MHz 2480MHz
<p>*As a result of preliminary test, the formal test was performed with the above modes, which had the maximum payload length (except Dwell time test)</p> <p>*EUT has the power settings by the software as follows; Power settings: Tx_Power_Level: Specify Power Table Index Transmit_Power_Table_Index: 0 Software: Broadcom BlueTool Version 1.4.5.4</p> <p>*This setting of software is the worst case. Any conditions under the normal use do not exceed the condition of setting. In addition, end users cannot change the settings of the output power of the product.</p>		

UL Japan, Inc.

Head Office EMC Lab.

4383-326 Asama-cho, Ise-shi, Mie-ken 516-0021 JAPAN

Telephone : +81 596 24 8116

Facsimile : +81 596 24 8124

4.2 Configuration and peripherals

<for Radiated emission test only>

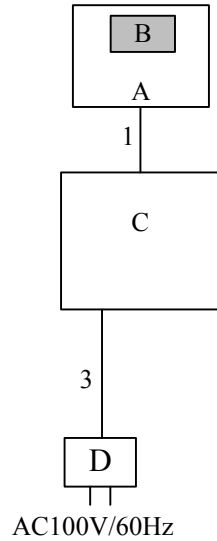

<for Antenna terminal conducted test only>

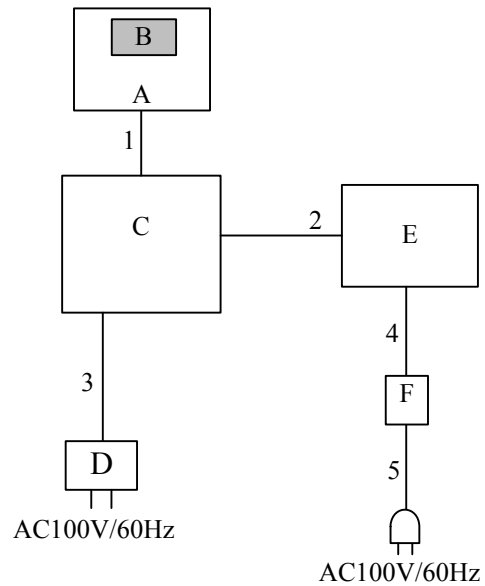

* Cabling and setup(s) were taken into consideration and test data was taken under worst case conditions.

Description of EUT

No.	Item	Model number	Serial number	Manufacturer	Remarks
A	3D Active Eyewear	TDG-BT400A	3	Sony Corporation	-
B	Bluetooth module	ARC0503	3	Hosiden Corporation	EUT
C	Interface Board	BCM920730EVAL-B64	1357705	Broadcom	-
D	AC Adapter	ACB0003A-05UR	-	Sunfone	-
E	Laptop PC	T61	L3-K0730	IBM	-
F	AC Adapter	92P1156	11S92P1156Z1Z DXN85M5PY	IBM	-

List of cables used

No.	Name	Length (m)	Shield		Remarks
			Cable	Connector	
1	Signal Cable	0.1	Unshielded	Unshielded	-
2	UART-USB Cable	1.1	Shielded	Shielded	-
3	USB Cable	1.4	Shielded	Shielded	DC Power Supply
4	DC Cable	1.8	Unshielded	Unshielded	-
5	AC Cable	0.8	Unshielded	Unshielded	-

UL Japan, Inc.

Head Office EMC Lab.

4383-326 Asama-cho, Ise-shi, Mie-ken 516-0021 JAPAN

Telephone : +81 596 24 8116

Facsimile : +81 596 24 8124

SECTION 5: Radiated Spurious Emission

Test Procedure

EUT was placed on a urethane platform of nominal size, 0.5m by 1.0m, raised 0.8m above the conducting ground plane.

The Radiated Electric Field Strength has been measured in a Semi Anechoic Chamber with a ground plane.

The height of the measuring antenna varied between 1 and 4m and EUT was rotated a full revolution in order to obtain the maximum value of the electric field strength.

The measurements were performed for both vertical and horizontal antenna polarization with the Test Receiver, or the Spectrum Analyzer.

The measurements were made with the following detector function of the test receiver and the Spectrum analyzer (in linear mode).

The test was made with the detector (RBW/VBW) in the following table.

When using Spectrum analyzer, the test was made with adjusting span to zero by using peak hold.

Test Antennas are used as below;

Frequency	Below 30MHz	30MHz to 300MHz	300MHz to 1GHz	Above 1GHz
Antenna Type	Loop	Biconical	Logperiodic	Horn

In any 100kHz bandwidth outside the restricted band in which the spread spectrum intentional radiator is operating, the radio frequency power that is produced by the intentional radiator confirmed 20dB below that in the 100kHz bandwidth within the band that contains the highest level of the desired power, based on a radiated measurement.

20dBc was applied to the frequency over the limit of FCC 15.209 / Table 5 of RSS-Gen 7.2.5 (IC) and outside the restricted band of FCC15.205 / Table 3 of RSS-Gen 7.2.2 (IC).

Frequency	Below 1GHz	Above 1GHz		20dBc
Instrument used	Test Receiver	Spectrum Analyzer		Spectrum Analyzer
Detector	QP	PK	AV	PK
IF Bandwidth	BW 120kHz(T/R)	RBW: 1MHz VBW: 3MHz	RBW: 1MHz VBW: 10Hz *1)	RBW: 100kHz VBW: 300kHz (S/A)
Test Distance	3m	3m (below 10GHz)		3m (below 10GHz)

*1) Although 00-705 accepts VBW=10Hz for AV measurements, it was confirmed that superfluous smoothing was not performed.”

- The carrier level and noise levels were confirmed at each position of X, Y and Z axes of EUT to see the position of maximum noise, and the test was made at the position that has the maximum noise.

The test results and limit are rounded off to one decimal place, so some differences might be observed.

Measurement range : 30M-25GHz
Test data : APPENDIX
Test result : Pass

UL Japan, Inc.

Head Office EMC Lab.

4383-326 Asama-cho, Ise-shi, Mie-ken 516-0021 JAPAN

Telephone : +81 596 24 8116

Facsimile : +81 596 24 8124

SECTION 6: Antenna Terminal Conducted Tests

Test Procedure

The tests were made with below setting connected to the antenna port.

Test	Span	RBW	VBW	Sweep time	Detector	Trace	Instrument used
20dB Bandwidth	3MHz	30kHz	100kHz	Auto	Peak	Max Hold	Spectrum Analyzer
99% Occupied Bandwidth	Enough width to display 20dB Bandwidth	1 to 3% of Span	Three times of RBW	Auto	Peak	Max Hold	Spectrum Analyzer
Maximum Peak Output Power	-	-	-	Auto	Peak	-	Power Meter (Sensor: 50MHz BW)
Carrier Frequency Separation	5MHz	30kHz	100kHz	Auto	Peak	Max Hold	Spectrum Analyzer
Number of Hopping Frequency	30MHz	300kHz	1MHz	Auto	Peak	Max Hold	Spectrum Analyzer
Dwell Time	Zero Span	100kHz, 1MHz	300kHz, 3MHz	As necessary capture the entire dwell time per hopping channel	Peak	Max Hold	Spectrum Analyzer
Conducted Spurious Emission *1)	9kHz to 150kHz	200Hz	620Hz	Auto	Peak	Max Hold	Spectrum Analyzer
	150kHz to 30MHz	9.1kHz	27kHz				
	30MHz to 25GHz (Less or equal to 5GHz)	100kHz	300kHz				
*1) In the frequency range below 30MHz, RBW was narrowed to separate the noise contents. Then, wide-band noise near the limit was checked separately, however the noise was not detected as shown in the chart.(9kHz-150kHz:RBW=200Hz, 150kHz-30MHz:RBW=9.1kHz)							

The test results and limit are rounded off to two decimals place, so some differences might be observed.

Test data : **APPENDIX**
Test result : **Pass**

APPENDIX 1: Data of EMI test

20dB Bandwidth and Carrier Frequency Separation

Test place Head Office EMC Lab. No.7 Shielded Room
Report No. 32JE0006-HO-01
Date 05/28/2012
Temperature/ Humidity 23 deg.C/ 46% RH
Engineer Motoya Imura
Mode Tx (Hopping on) DH5

Mode	Freq. [MHz]	20dB Bandwidth [MHz]	Carrier Frequency Separation [MHz]	Limit for Carrier Frequency separation [MHz]
DH5	2402.0	0.978	1.000	≥ 0.652
DH5	2441.0	1.008	1.000	≥ 0.672
DH5	2480.0	0.995	1.000	≥ 0.663

Limit: Two-thirds of 20dB Bandwidth or 25kHz (whichever is greater).
No limit applies to 20dB Bandwidth.

20dB Bandwidth and Carrier Frequency Separation

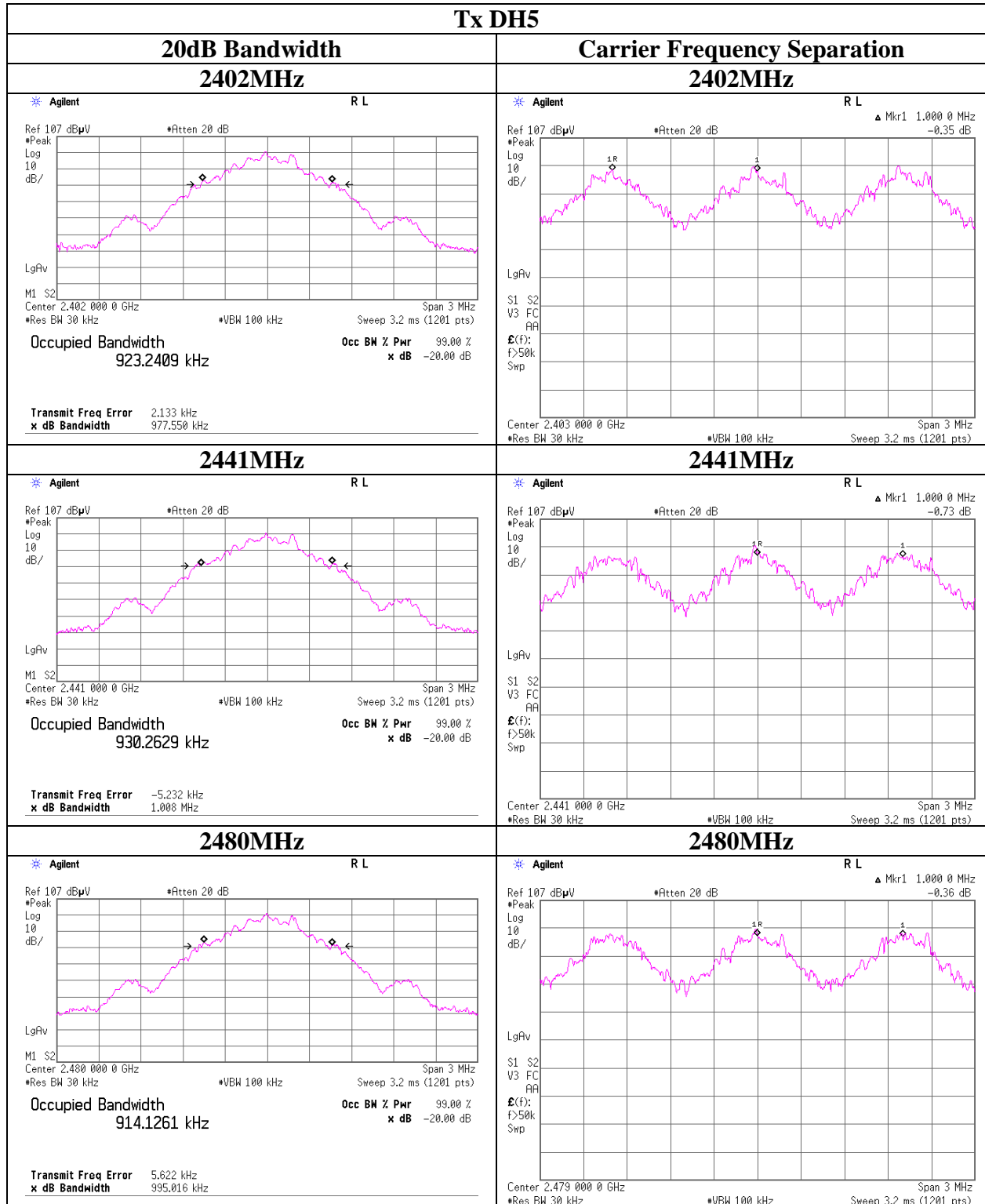

Number of Hopping Frequency

Test place Head Office EMC Lab. No.7 Shielded Room
Report No. 32JE0006-HO-01
Date 05/28/2012
Temperature/ Humidity 23 deg.C/ 46% RH
Engineer Motoya Imura
Mode Tx (Hopping on) DH5

Mode	Number of channel [times]	Limit [times]
DH5	79	>= 15

Test was not performed at AFH mode whose number of hopping channel is 20 channels because this Bluetooth radio is in compliance of Bluetooth Specification 3.0.

Number of Hopping Frequency

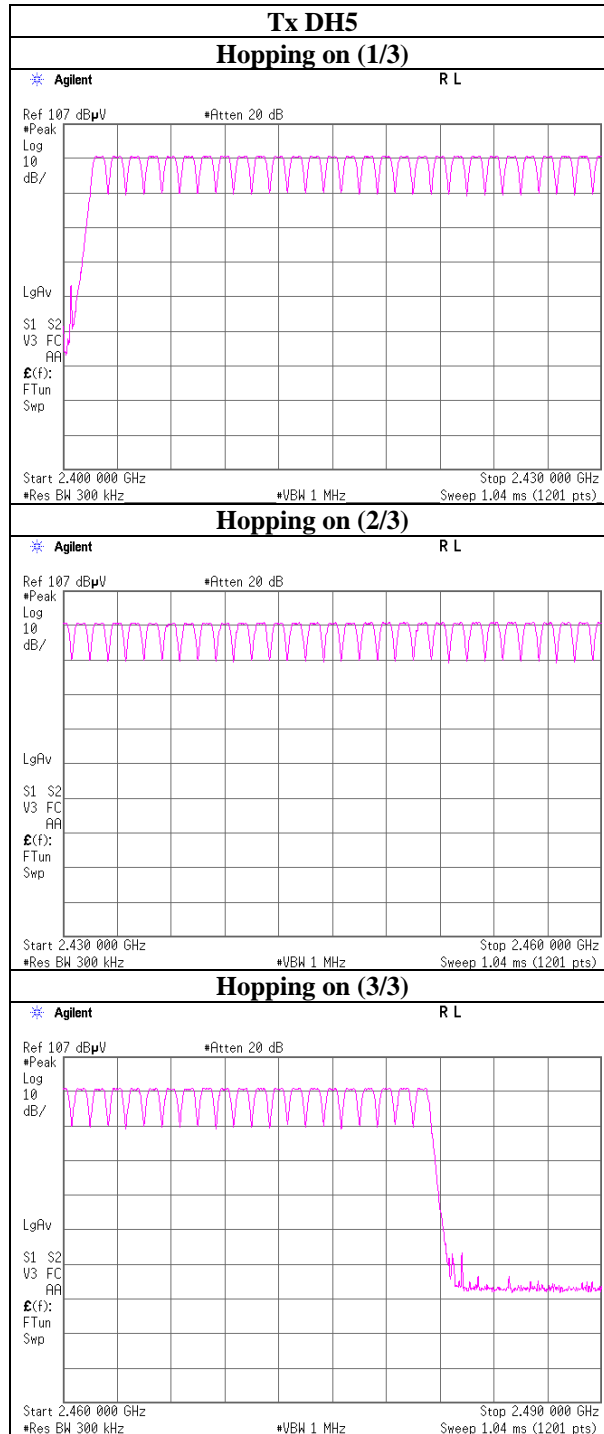

Dwell time

Test place	Head Office EMC Lab. No.7 Shielded Room
Report No.	32JE0006-HO-01
Date	05/28/2012
Temperature/ Humidity	23 deg.C/ 46% RH
Engineer	Motoya Imura
Mode	Tx (Hopping on) DH5

Mode	Number of transmission in a 31.6(79 Hopping x 0.4) / 12.8(32 Hopping x 0.4)second period	Length of transmission time [msec]	Result [msec]	Limit [msec]
DH1	51.2 times / 5 sec. x 31.6 sec. = 324 times	0.445	144	400
DH3	29.6 times / 5 sec. x 31.6 sec. = 188 times	1.705	321	400
DH5	20.4 times / 5 sec. x 31.6 sec. = 129 times	2.961	382	400

Sample Calculation

Result = Number of transmission x Length of transmission time

*Average data of 5 tests.(except Inquiry)

Mode	Sampling [times]					Average [times]
	1	2	3	4	5	
DH1	51	51	51	52	51	51.2
DH3	29	29	31	30	29	29.6
DH5	21	19	22	21	19	20.4

Sample Calculation

Average= Summation(Sampling 1 to 5) / 5

This device complies with the Bluetooth protocol for FHSS operation, employing a pseudo random channel selection and hopping rate to ensure that the occupancy time in $N \times 0.4s$, where N is the number of channels being used in the hopping sequence ($20 \leq N \leq 79$), is always less than $0.4s$ regardless of packet size (DH1, DH3 or DH5). This is confirmed in the test report for $N=79$.

Dwell time

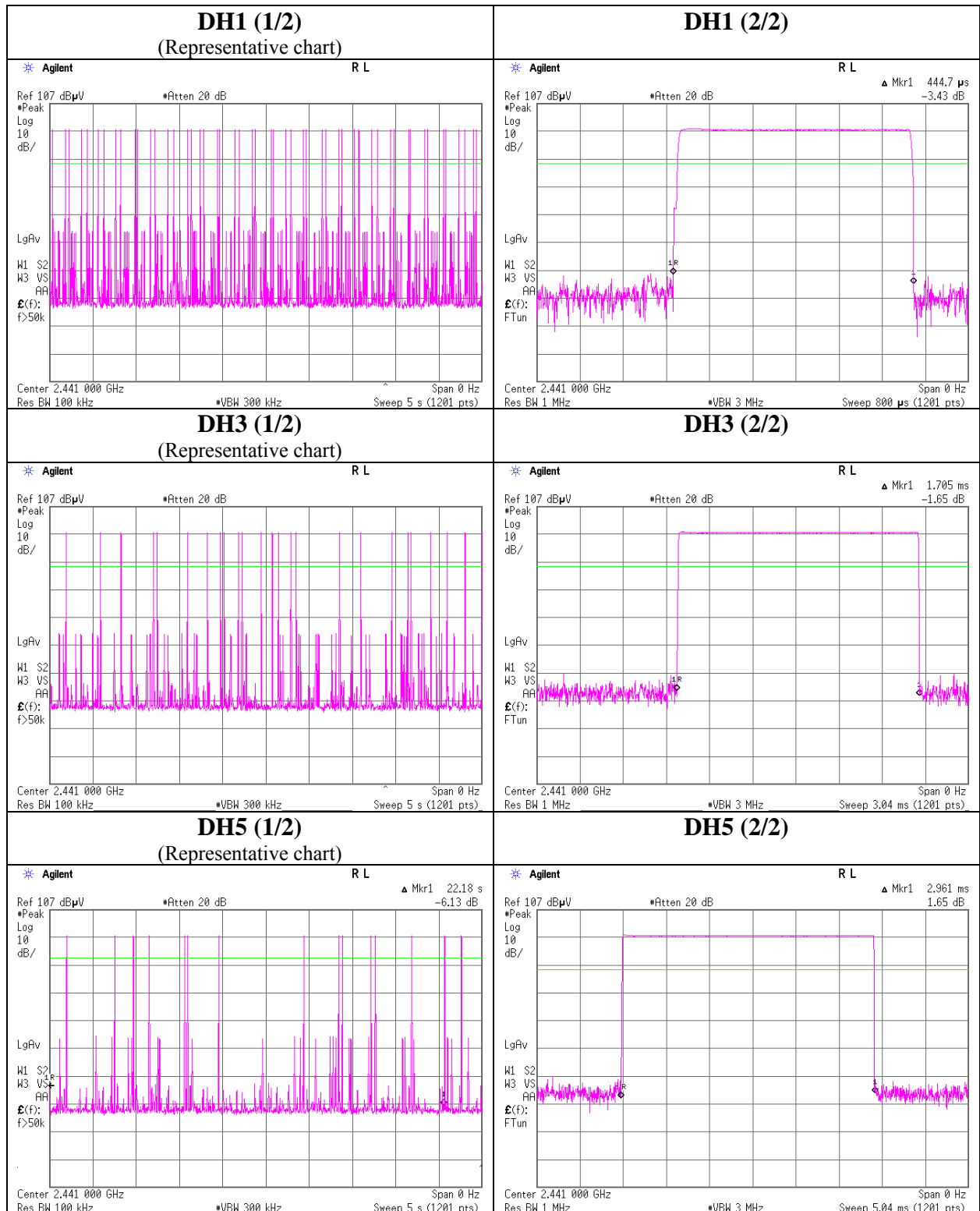

Maximum Peak Output Power

Test place Head Office EMC Lab. No.7 Shielded Room
Report No. 32JE0006-HO-01
Date 05/28/2012
Temperature/ Humidity 23 deg.C/ 46% RH
Engineer Motoya Imura
Mode Tx (Hopping off) DH5

Mode	Freq. [MHz]	Reading (P/M) [dBm]	Cable Loss [dB]	Atten. [dB]	Result		Limit		Margin [dB]
					[dBm]	[mW]	[dBm]	[mW]	
DH5	2402.0	-9.29	1.30	10.08	2.09	1.62	20.96	125	18.87
DH5	2441.0	-9.27	1.30	10.08	2.11	1.63	20.96	125	18.85
DH5	2480.0	-9.16	1.30	10.09	2.23	1.67	20.96	125	18.73

Sample Calculation:

Result = Reading + Cable Loss (including the cable(s) customer supplied)+ Attenuator

Radiated Spurious Emission

Test place Head Office EMC Lab. No.3 and No.4 Semi Anechoic Chamber
Report No. 32JE0006-HO-01
Date 06/20/2012 06/21/2012
Temperature/ Humidity 25 deg.C/ 61% RH 24 deg.C/ 59% RH
Engineer Satofumi Matsuyama Hiroshi Kukita
(Above 1GHz) (Below 1GHz)
Mode Tx, DH5 2402MHz

Polarity	Frequency [MHz]	Detector	Reading [dBuV]	Ant.Fac. [dB/m]	Loss [dB]	Gain [dB]	Result [dBuV/m]	Limit [dBuV/m]	Margin [dB]	Remark
Hori	39.538	QP	24.0	15.1	7.3	32.2	14.2	40.0	25.8	
Hori	59.718	QP	25.4	8.1	7.6	32.2	8.9	40.0	31.1	
Hori	68.938	QP	28.1	6.8	7.7	32.2	10.4	40.0	29.6	
Hori	117.026	QP	23.0	12.5	8.4	32.3	11.6	43.5	31.9	
Hori	2390.000	PK	48.5	28.1	2.4	32.3	46.7	73.9	27.2	
Hori	4804.000	PK	46.6	31.2	5.1	31.5	51.4	73.9	22.5	
Hori	7206.000	PK	45.2	35.6	5.9	32.5	54.2	73.9	19.7	
Hori	2390.000	AV	30.0	28.1	2.4	32.3	28.2	53.9	25.7	
Hori	4804.000	AV	37.4	31.2	5.1	31.5	42.2	53.9	11.7	
Hori	7206.000	AV	34.5	35.6	5.9	32.5	43.5	53.9	10.4	
Vert	39.332	QP	33.8	15.2	7.3	32.2	24.1	40.0	15.9	
Vert	59.718	QP	43.4	8.1	7.6	32.2	26.9	40.0	13.1	
Vert	68.944	QP	48.0	6.8	7.7	32.2	30.3	40.0	9.7	
Vert	117.006	QP	34.2	12.5	8.4	32.3	22.8	43.5	20.7	
Vert	2390.000	PK	47.0	28.1	2.4	32.3	45.2	73.9	28.7	
Vert	4804.000	PK	46.3	31.2	5.1	31.5	51.1	73.9	22.8	
Vert	7206.000	PK	45.3	35.6	5.9	32.5	54.3	73.9	19.6	
Vert	2390.000	AV	29.9	28.1	2.4	32.3	28.1	53.9	25.8	
Vert	4804.000	AV	38.5	31.2	5.1	31.5	43.3	53.9	10.6	
Vert	7206.000	AV	33.6	35.6	5.9	32.5	42.6	53.9	11.3	

Result = Reading + Ant Factor + Loss (Cable+Attenuator+Filter-Distance factor(above 10GHz)) - Gain(Amplifier)

*Other frequency noises omitted in this report were not seen or had enough margin (more than 20dB).

*The 10th harmonic was not seen so the result was its base noise level.

Distance factor: 10GHz-26.5GHz 20log(3.0m/1.0m)= 9.5dB

26.5GHz-40GHz 20log(3.0m/0.5m)=15.6dB

20dBc Data Sheet

Polarity	Frequency [MHz]	Detector	Reading [dBuV]	Ant Factor [dB/m]	Loss [dB]	Gain [dB]	Result [dBuV/m]	Limit [dBuV/m]	Margin [dB]	Remark
Hori	2402.000	PK	98.2	28.1	2.4	32.3	96.4	-	-	Carrier
Hori	2400.000	PK	53.9	28.1	2.4	32.3	52.1	76.4	24.3	
Vert	2402.000	PK	94.2	28.1	2.4	32.3	92.4	-	-	Carrier
Vert	2400.000	PK	50.1	28.1	2.4	32.3	48.3	72.4	24.1	

Result = Reading + Ant Factor + Loss (Cable+Attenuator+Filter-Distance factor(above 10GHz)) - Gain(Amplifier)

Radiated Spurious Emission

Test place Head Office EMC Lab. No.3 and No.4 Semi Anechoic Chamber
Report No. 32JE0006-HO-01
Date 06/20/2012 06/21/2012
Temperature/ Humidity 25 deg.C/ 61% RH 24 deg.C/ 59% RH
Engineer Satofumi Matsuyama Hiroshi Kukita
(Above 1GHz) (Below 1GHz)
Mode Tx, DH5 2441MHz

Polarity	Frequency [MHz]	Detector	Reading [dBuV]	Ant.Fac. [dB/m]	Loss [dB]	Gain [dB]	Result [dBuV/m]	Limit [dBuV/m]	Margin [dB]	Remark
Hori	39.552	QP	23.8	15.1	7.3	32.2	14.0	40.0	26.0	
Hori	59.722	QP	25.0	8.1	7.6	32.2	8.5	40.0	31.5	
Hori	68.921	QP	27.7	6.8	7.7	32.2	10.0	40.0	30.0	
Hori	117.930	QP	22.9	12.7	8.4	32.3	11.7	43.5	31.8	
Hori	4882.000	PK	46.6	31.4	5.2	31.5	51.7	73.9	22.2	
Hori	7323.000	PK	44.7	35.7	5.9	32.5	53.8	73.9	20.1	
Hori	4882.000	AV	36.7	31.4	5.2	31.5	41.8	53.9	12.1	
Hori	7323.000	AV	33.0	35.7	5.9	32.5	42.1	53.9	11.8	
Vert	39.350	QP	34.0	15.2	7.3	32.2	24.3	40.0	15.7	
Vert	59.750	QP	44.0	8.1	7.6	32.2	27.5	40.0	12.5	
Vert	68.928	QP	47.7	6.8	7.7	32.2	30.0	40.0	10.0	
Vert	117.002	QP	33.5	12.5	8.4	32.3	22.1	43.5	21.4	
Vert	4882.000	PK	47.9	31.4	5.2	31.5	53.0	73.9	20.9	
Vert	7323.000	PK	44.5	35.7	5.9	32.5	53.6	73.9	20.3	
Vert	4882.000	AV	40.9	31.4	5.2	31.5	46.0	53.9	7.9	
Vert	7323.000	AV	32.9	35.7	5.9	32.5	42.0	53.9	11.9	

Result = Reading + Ant Factor + Loss (Cable+Attenuator+Filter-Distance factor(above 10GHz)) - Gain(Amplifier)

*Other frequency noises omitted in this report were not seen or had enough margin (more than 20dB).

*The 10th harmonic was not seen so the result was its base noise level.

Distance factor: 10GHz-26.5GHz 20log(3.0m/1.0m)= 9.5dB
26.5GHz-40GHz 20log(3.0m/0.5m)=15.6dB

Radiated Spurious Emission

Test place Head Office EMC Lab. No.3 and No.4 Semi Anechoic Chamber
Report No. 32JE0006-HO-01
Date 06/20/2012 06/21/2012
Temperature/ Humidity 25 deg.C/ 61% RH 24 deg.C/ 59% RH
Engineer Satofumi Matsuyama Hiroshi Kukita
(Above 1GHz) (Below 1GHz)
Mode Tx, DH5 2480MHz

Polarity	Frequency [MHz]	Detector	Reading [dBuV]	Ant.Fac. [dB/m]	Loss [dB]	Gain [dB]	Result [dBuV/m]	Limit [dBuV/m]	Margin [dB]	Remark
Hori	39.554	QP	23.5	15.1	7.3	32.2	13.7	40.0	26.3	
Hori	59.770	QP	24.8	8.1	7.6	32.2	8.3	40.0	31.7	
Hori	68.919	QP	27.7	6.8	7.7	32.2	10.0	40.0	30.0	
Hori	117.028	QP	23.3	12.5	8.4	32.3	11.9	43.5	31.6	
Hori	2483.500	PK	53.6	28.5	2.4	32.2	52.3	73.9	21.6	
Hori	4960.000	PK	43.8	31.6	5.2	31.5	49.1	73.9	24.8	
Hori	7440.000	PK	44.9	35.8	6.0	32.6	54.1	73.9	19.8	
Hori	2483.500	AV	31.4	28.5	2.4	32.2	30.1	53.9	23.8	
Hori	4960.000	AV	33.6	31.6	5.2	31.5	38.9	53.9	15.0	
Hori	7440.000	AV	33.2	35.8	6.0	32.6	42.4	53.9	11.5	
Vert	39.340	QP	34.1	15.2	7.3	32.2	24.4	40.0	15.6	
Vert	59.732	QP	43.5	8.1	7.6	32.2	27.0	40.0	13.0	
Vert	68.930	QP	46.9	6.8	7.7	32.2	29.2	40.0	10.8	
Vert	117.013	QP	35.0	12.5	8.4	32.3	23.6	43.5	19.9	
Vert	2483.500	PK	51.5	28.5	2.4	32.2	50.2	73.9	23.7	
Vert	4960.000	PK	47.7	31.6	5.2	31.5	53.0	73.9	20.9	
Vert	7440.000	PK	45.7	35.8	6.0	32.6	54.9	73.9	19.0	
Vert	2483.500	AV	30.8	28.5	2.4	32.2	29.5	53.9	24.4	
Vert	4960.000	AV	40.9	31.6	5.2	31.5	46.2	53.9	7.7	
Vert	7440.000	AV	33.3	35.8	6.0	32.6	42.5	53.9	11.4	

Result = Reading + Ant Factor + Loss (Cable+Attenuator+Filter-Distance factor(above 10GHz)) - Gain(Amplifier)

*Other frequency noises omitted in this report were not seen or had enough margin (more than 20dB).

*The 10th harmonic was not seen so the result was its base noise level.

Distance factor: 10GHz-26.5GHz 20log(3.0m/1.0m)= 9.5dB
26.5GHz-40GHz 20log(3.0m/0.5m)=15.6dB

Conducted Spurious Emission

Tx DH5 2402MHz

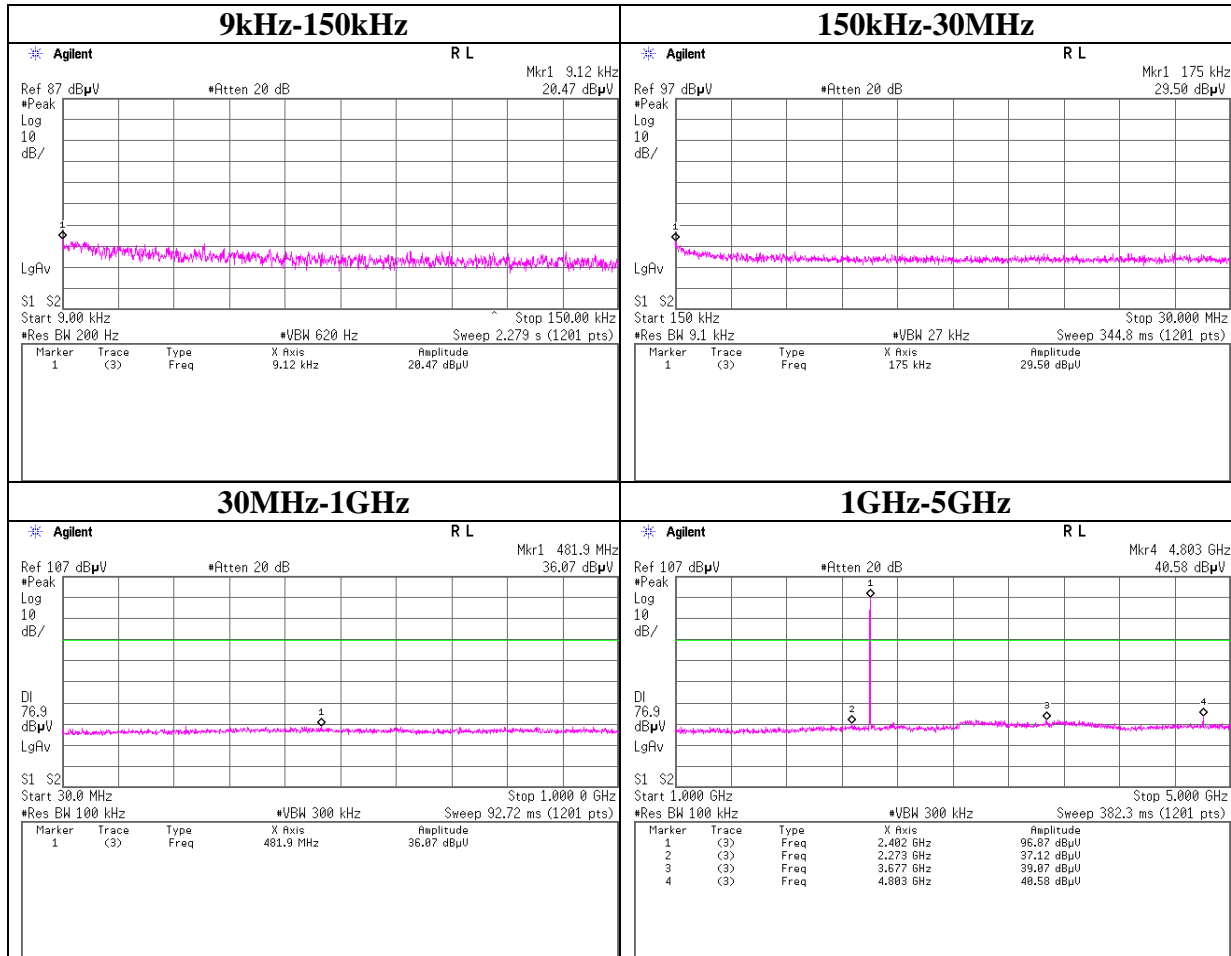

Conducted Spurious Emission

Tx DH5 2402MHz

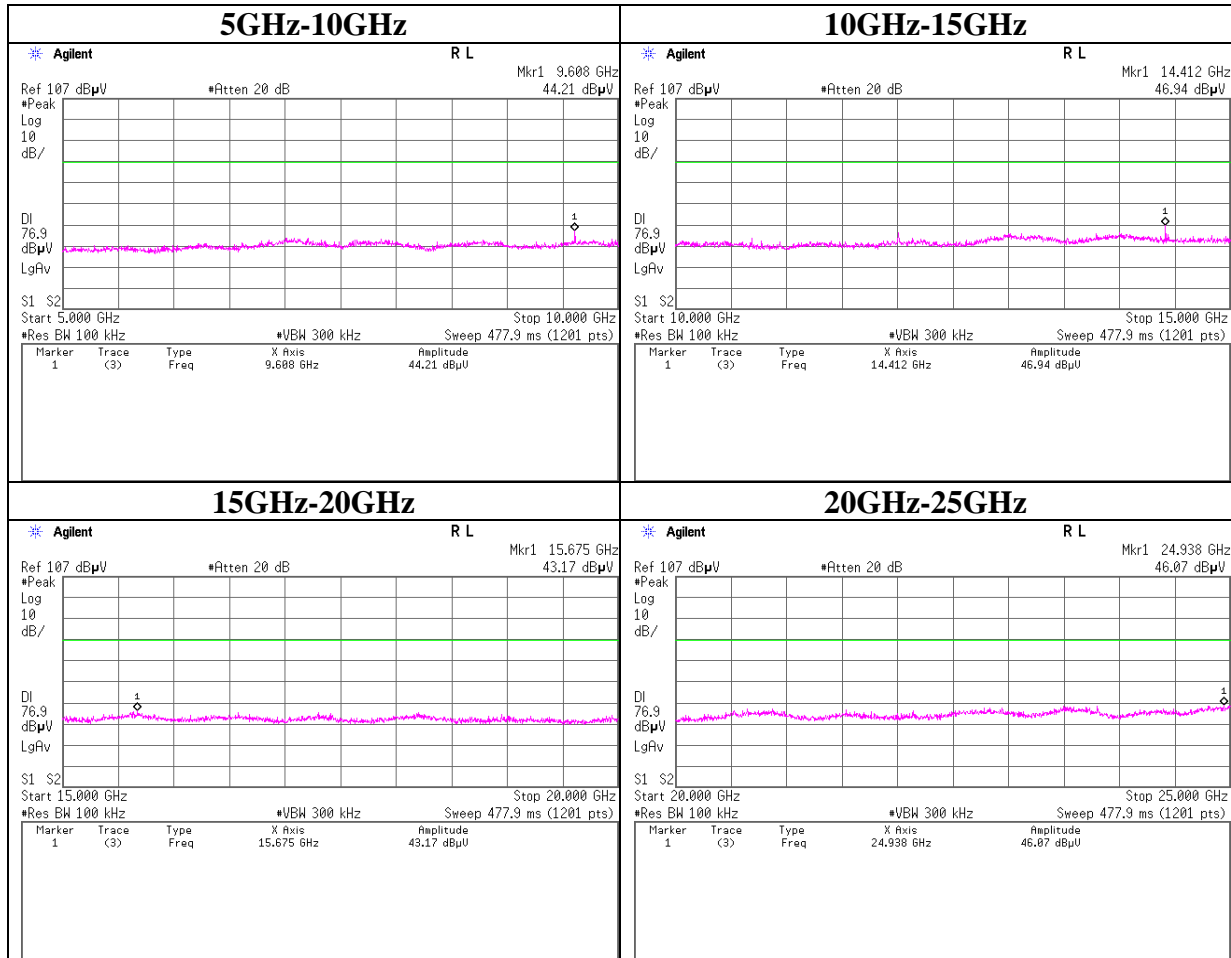

Conducted Spurious Emission

Tx DH5 2441MHz

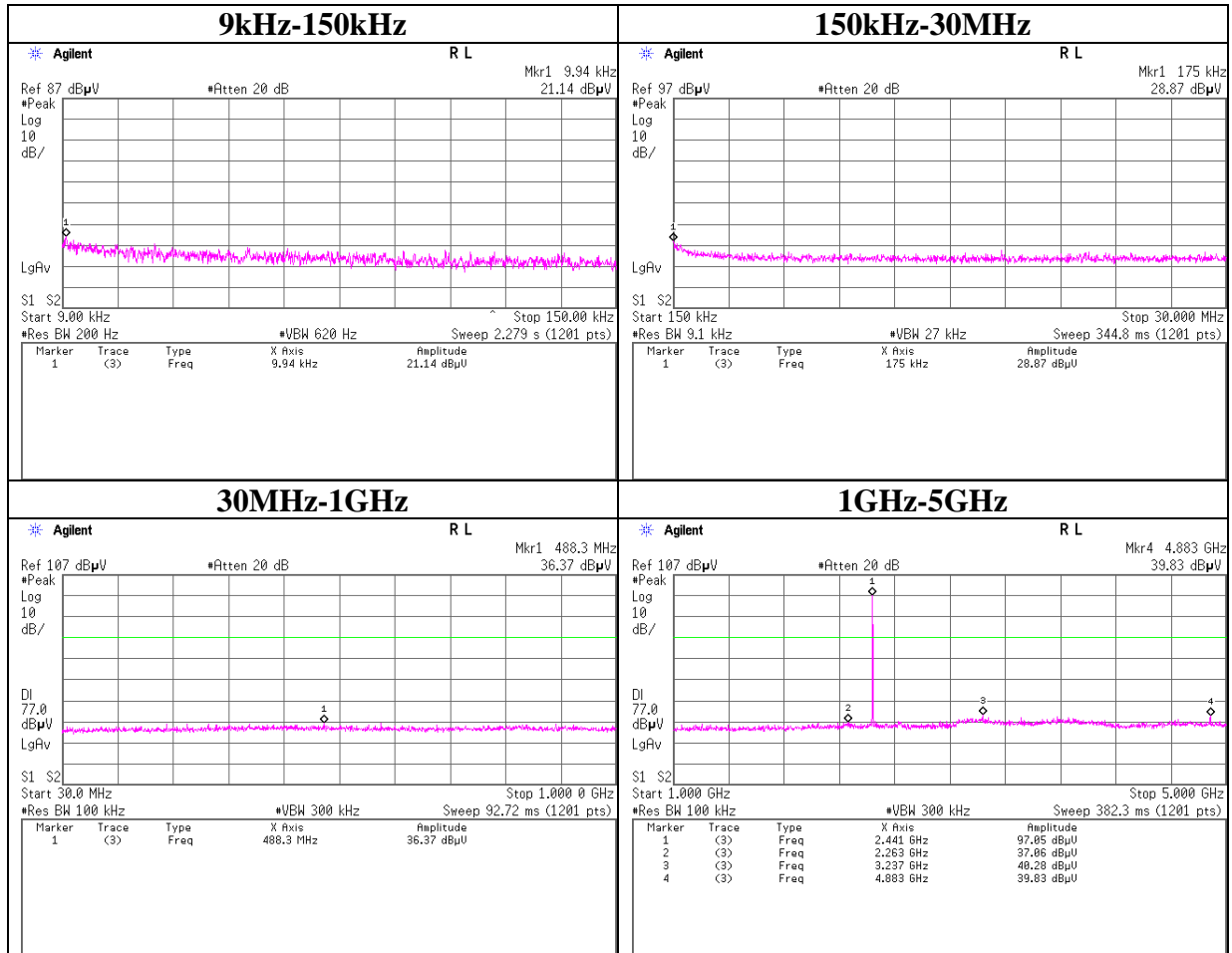

Conducted Spurious Emission

Tx DH5 2441MHz

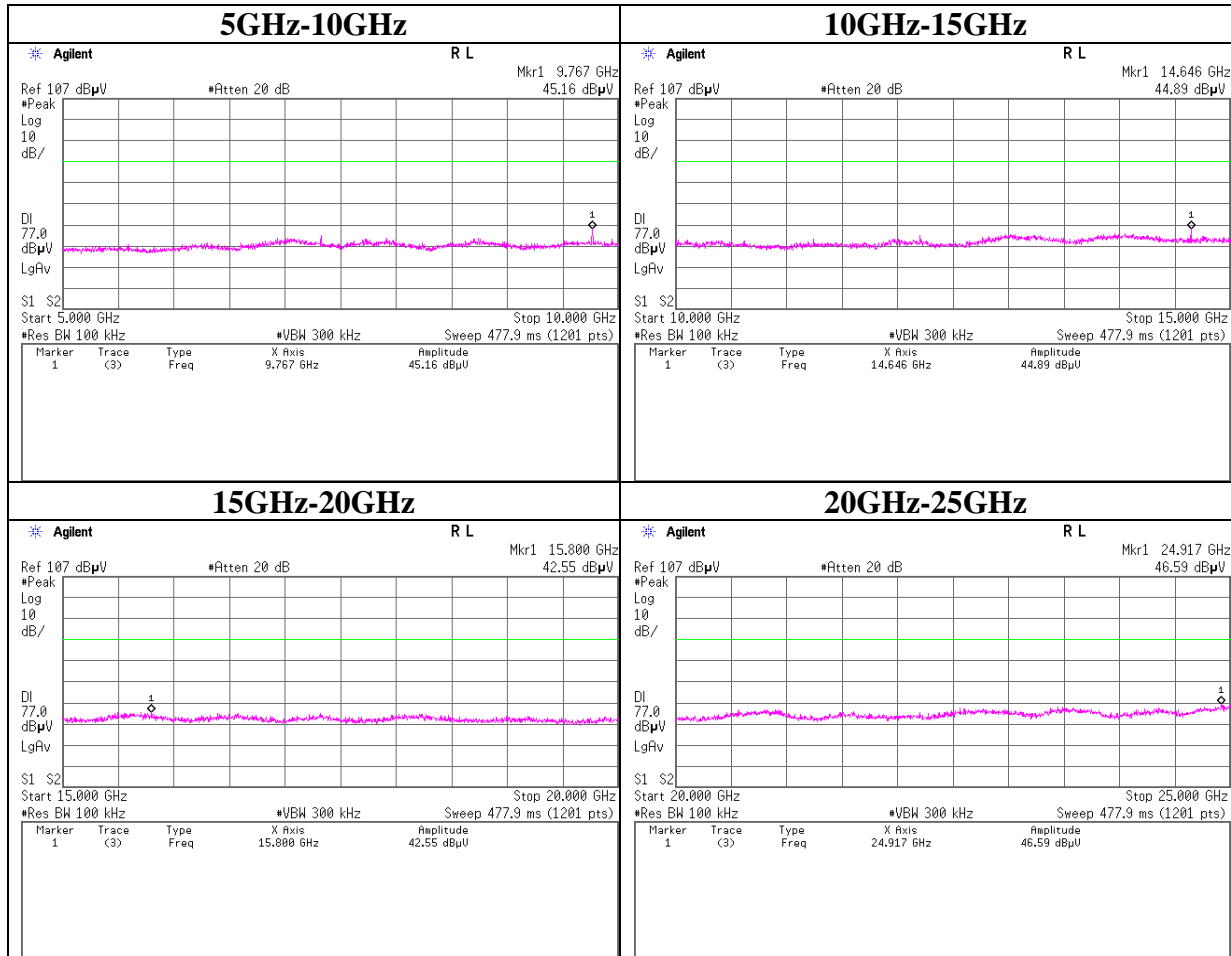

Conducted Spurious Emission

Tx DH5 2480MHz

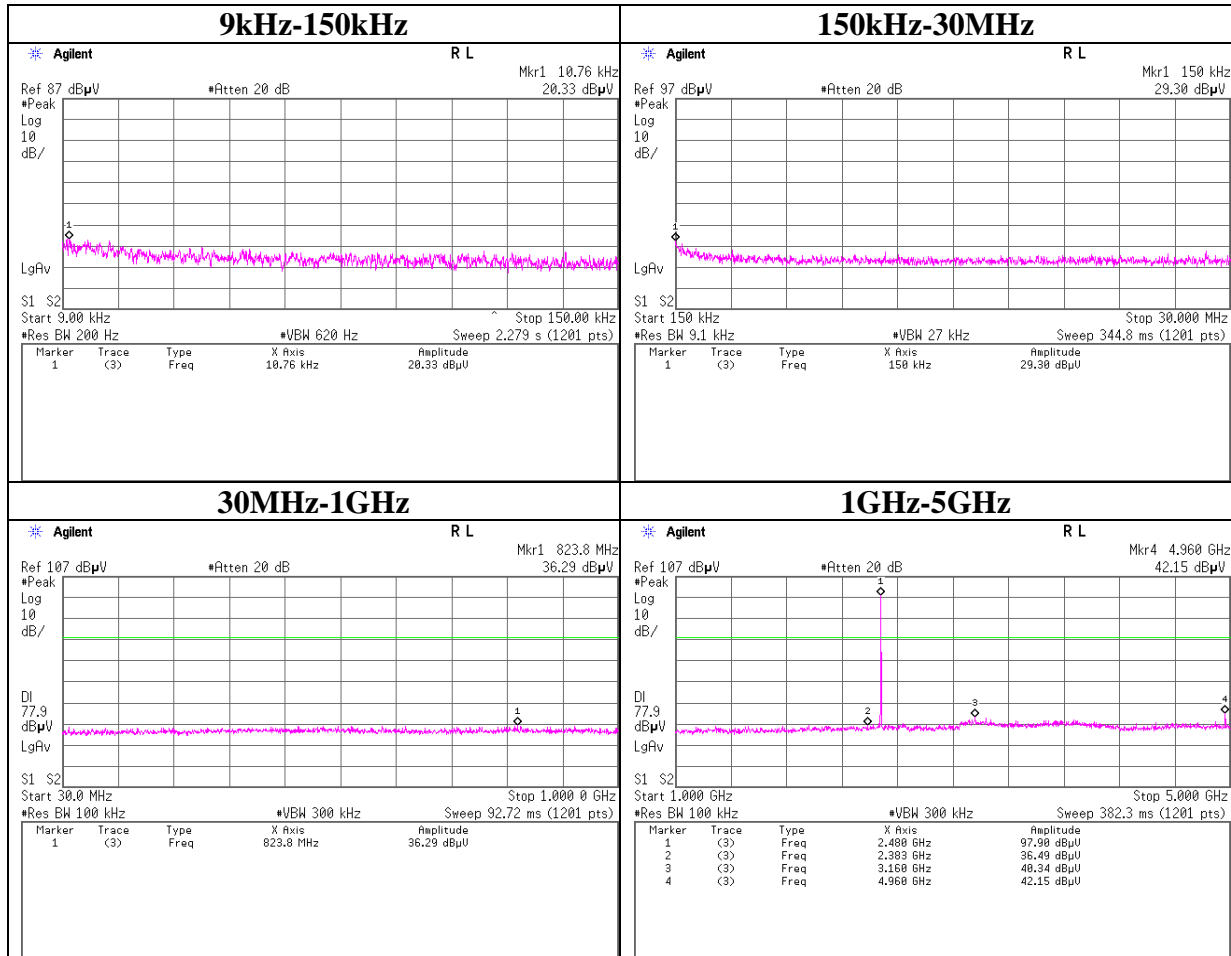

Conducted Spurious Emission

Tx DH5 2480MHz

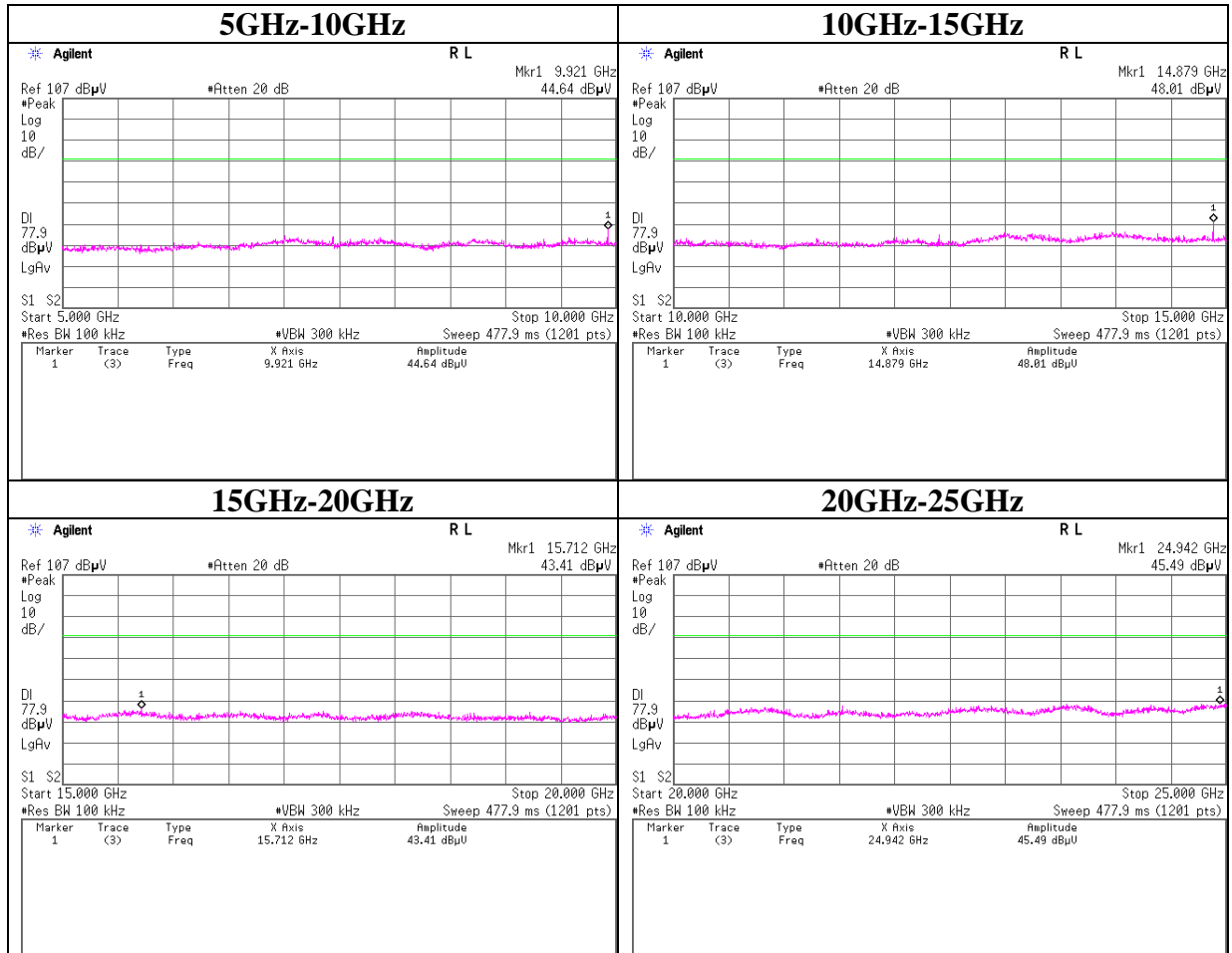

Conducted Emission Band Edge compliance

Tx DH5, Hopping on

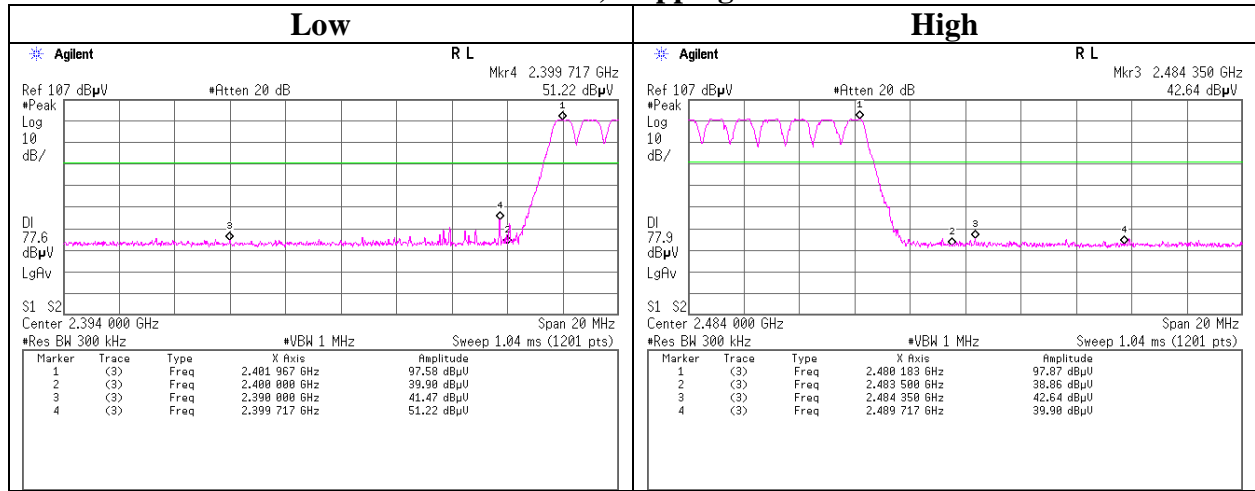

Tx DH5, Hopping off

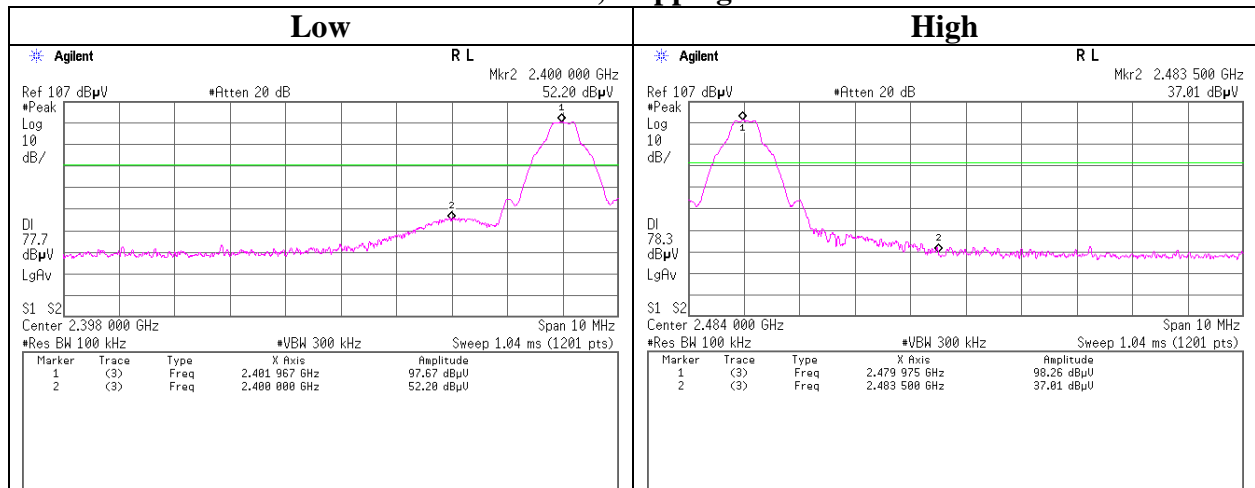

99% Occupied Bandwidth

Tx DH5, Hopping off

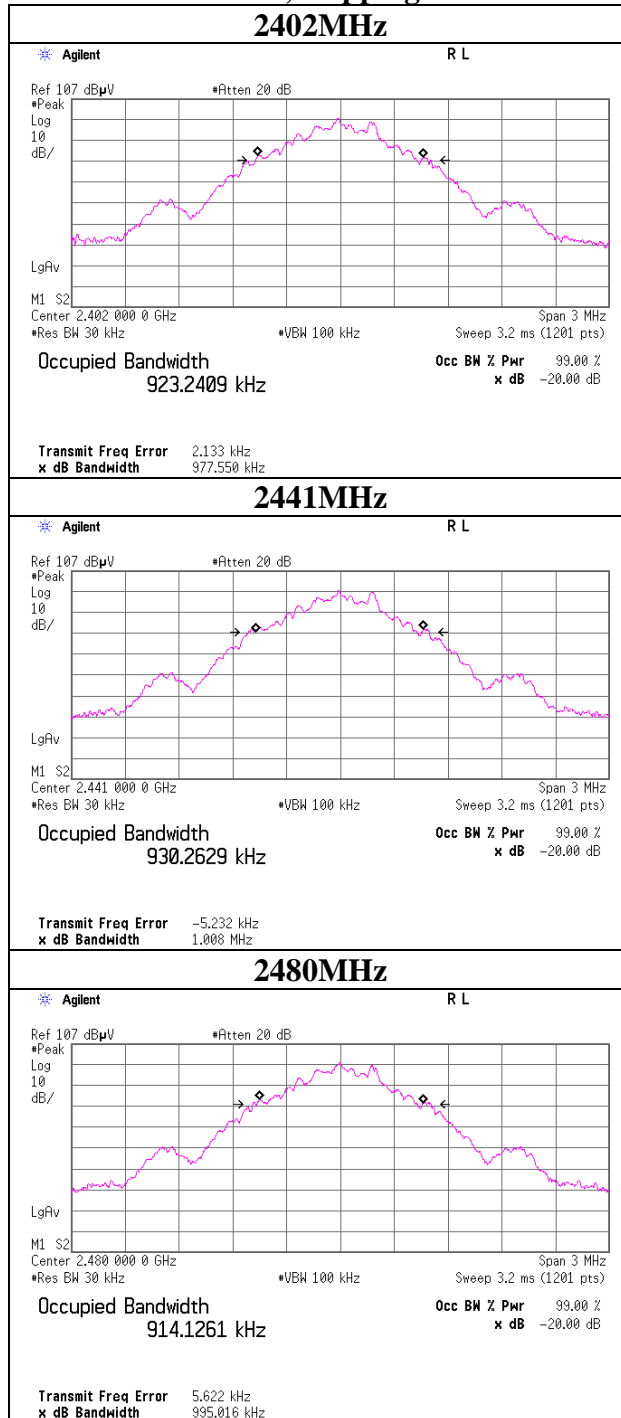

99% Occupied Bandwidth

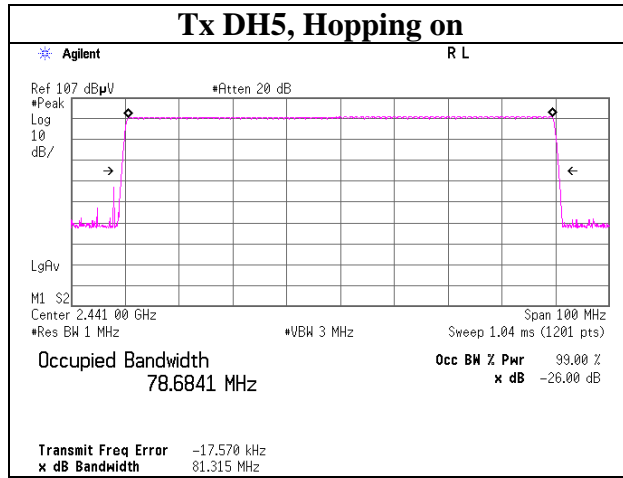

APPENDIX 2: Test instruments

EMI test equipment

Control No.	Instrument	Manufacturer	Model No	Serial No	Test Item	Calibration Date * Interval(month)
MOS-04	Digital Humidity Indicator	N.T	NT-1800	MOS04	AT	2012/02/06 * 12
MBM-11	Barometer	Sunoh	SBR121	839	AT	2010/12/13 * 36
MSA-04	Spectrum Analyzer	Agilent	E4448A	US44300523	AT	2012/04/06 * 12
MPM-09	Power Meter	Anritsu	ML2495A	6K00003348	AT	2011/09/12 * 12
MPSE-12	Power sensor	Anritsu	MA2411B	011598	AT	2011/09/12 * 12
MAT-20	Attenuator(10dB)(above1 GHz)	HIROSE ELECTRIC CO.,LTD.	AT-110	-	AT	2012/01/12 * 12
MAEC-03	Semi Anechoic Chamber(NSA)	TDK	Semi Anechoic Chamber 3m	DA-10005	RE	2012/02/24 * 12
MOS-13	Thermo-Hygrometer	Custom	CTH-180	-	RE	2012/02/06 * 12
MJM-06	Measure	PROMART	SEN1955	-	RE	
COTS-MEMI	EMI measurement program	TSJ	TEPTO-DV	-	RE	-
MSA-03	Spectrum Analyzer	Agilent	E4448A	MY44020357	RE	2011/11/23 * 12
MHA-20	Horn Antenna 1-18GHz	Schwarzbeck	BBHA9120D	258	RE	2012/05/25 * 12
MCC-133	Microwave Cable	HUBER+SUHNER	SUCOFLEX104	336164/4(1m) / 340640(5m)	RE	2011/09/07 * 12
MPA-11	MicroWave System Amplifier	Agilent	83017A	MY39500779	RE	2012/03/29 * 12
MSA-10	Spectrum Analyzer	Agilent	E4448A	MY46180655	RE	2012/02/03 * 12
MTR-07	Test Receiver	Rohde & Schwarz	ESCI	100635	RE	2012/04/05 * 12
MBA-03	Biconical Antenna	Schwarzbeck	BBA9106	1915	RE	2011/10/15 * 12
MLA-03	Logperiodic Antenna	Schwarzbeck	USLP9143	174	RE	2011/10/15 * 12
MCC-51	Coaxial cable	UL Japan	-	-	RE	2011/07/15 * 12
MAT-09	Attenuator(6dB)	Weinschel Corp	2	BK7973	RE	2011/11/02 * 12
MPA-13	Pre Amplifier	SONOMA INSTRUMENT	310	260834	RE	2012/03/16 * 12
MAEC-04	Semi Anechoic Chamber(NSA)	TDK	Semi Anechoic Chamber 3m	DA-10005	RE	2012/02/29 * 12
MOS-15	Thermo-Hygrometer	Custom	CTH-180	-	RE	2012/02/06 * 12
MJM-07	Measure	PROMART	SEN1955	-	RE	-
MSA-10	Spectrum Analyzer	Agilent	E4448A	MY46180655	RE	2012/02/03 * 12
MHA-21	Horn Antenna 1-18GHz	Schwarzbeck	BBHA9120D	9120D-557	RE	2011/08/11 * 12
MCC-141	Microwave Cable	Junkosha	MWX221	1203S212(1m) / 1204S062(5m)	RE	2012/04/23 * 12
MPA-12	MicroWave System Amplifier	Agilent	83017A	MY39500780	RE	2012/03/28 * 12
MHA-17	Horn Antenna 15-40GHz	Schwarzbeck	BBHA9170	BBHA9170307	RE	2011/06/17 * 12
MHF-20	High Pass Filter 3.5-18.0GHz	TOKIMEC	TF323DCC	607	RE	2011/09/08 * 12
MCC-79	Microwave Cable 1G-26.5GHz	Suhner	SUCOFLEX104	278923/4	RE	2011/12/08 * 12

The expiration date of the calibration is the end of the expired month.

All equipment is calibrated with valid calibrations. Each measurement data is traceable to the national or international standards.

As for some calibrations performed after the tested dates, those test equipment have been controlled by means of an unbroken chains of calibrations.

Test Item: RE: Radiated Emission

AT: Antenna Terminal Conducted test

UL Japan, Inc.

Head Office EMC Lab.

4383-326 Asama-cho, Ise-shi, Mie-ken 516-0021 JAPAN

Telephone : +81 596 24 8116

Facsimile : +81 596 24 8124