

FCC Radio Test Report

FCC ID: VIXSP201

This report concerns (check one): Original Grant Class I Change Class II Change

Project No. : 1710179
Equipment : WIRELESS SPEAKER
Model Name : SP201
Applicant : Voxx Accessories Corp.
Address : 3502 Woodview Trace, Suite 220 Indianapolis, IN
46268 USA

Date of Receipt : Nov. 01, 2017
Date of Test : Nov. 01, 2017 ~ Nov. 16, 2017
Issued Date : Nov. 17, 2017
Tested by : BTL Inc.

Testing Engineer : Rot Liang
(Rot Liang)

Technical Manager : Shawn Xiao
(Shawn Xiao)

Authorized Signatory : David Mao
(David Mao)

B T L I N C .

No.3, Jinshagang 1st Road, Shixia, Dalang Town, Dongguan,
Guangdong, China.

TEL: +86-769-8318-3000 FAX: +86-769-8319-6000



Declaration

BTL represents to the client that testing is done in accordance with standard procedures as applicable and that test instruments used has been calibrated with standards traceable to international standard(s) and/or national standard(s).

BTL's reports apply only to the specific samples tested under conditions. It is manufacture's responsibility to ensure that additional production units of this model are manufactured with the identical electrical and mechanical components. **BTL** shall have no liability for any declarations, inferences or generalizations drawn by the client or others from **BTL** issued reports.

BTL's report must not be used by the client to claim product certification, approval, or endorsement by NVLAP, NIST, or any agency of the Federal Government.

This report is the confidential property of the client. As a mutual protection to the clients, the public and **BTL-self**, extracts from the test report shall not be reproduced except in full with **BTL's** authorized written approval.

BTL's laboratory quality assurance procedures are in compliance with the **ISO Guide 17025** requirements, and accredited by the conformity assessment authorities listed in this test report.

Limitation

For the use of the authority's logo is limited unless the Test Standard(s)/Scope(s)/Item(s) mentioned in this test report is (are) included in the conformity assessment authorities acceptance respective.

| Table of Contents | Page |
|--|-------------|
| 1 . CERTIFICATION | 7 |
| 2 . SUMMARY OF TEST RESULTS | 8 |
| 2.1 TEST FACILITY | 9 |
| 2.2 MEASUREMENT UNCERTAINTY | 9 |
| 3 . GENERAL INFORMATION | 10 |
| 3.1 GENERAL DESCRIPTION OF EUT | 10 |
| 3.2 DESCRIPTION OF TEST MODES | 12 |
| 3.3 TABLE OF PARAMETERS OF TEXT SOFTWARE SETTING | 12 |
| 3.4 BLOCK DIAGRAM SHOWING THE CONFIGURATION OF SYSTEM TESTED | 13 |
| 3.5 DESCRIPTION OF SUPPORT UNITS | 13 |
| 4 . EMC EMISSION TEST | 14 |
| 4.1 CONDUCTED EMISSION MEASUREMENT | 14 |
| 4.1.1 POWER LINE CONDUCTED EMISSION LIMITS | 14 |
| 4.1.2 TEST PROCEDURE | 14 |
| 4.1.3 DEVIATION FROM TEST STANDARD | 14 |
| 4.1.4 TEST SETUP | 15 |
| 4.1.5 EUT OPERATING CONDITIONS | 15 |
| 4.1.6 EUT TEST CONDITIONS | 15 |
| 4.1.7 TEST RESULTS | 15 |
| 4.2 RADIATED EMISSION MEASUREMENT | 16 |
| 4.2.1 RADIATED EMISSION LIMITS | 16 |
| 4.2.2 TEST PROCEDURE | 17 |
| 4.2.3 DEVIATION FROM TEST STANDARD | 17 |
| 4.2.4 TEST SETUP | 18 |
| 4.2.5 EUT OPERATING CONDITIONS | 19 |
| 4.2.6 EUT TEST CONDITIONS | 19 |
| 4.2.7 TEST RESULTS (9KHZ TO 30MHZ) | 19 |
| 4.2.8 TEST RESULTS (30MHZ TO 1000MHZ) | 19 |
| 4.2.9 TEST RESULTS (ABOVE 1000MHZ) | 19 |
| 5 . NUMBER OF HOPPING CHANNEL | 20 |
| 5.1 APPLIED PROCEDURES | 20 |
| 5.1.1 TEST PROCEDURE | 20 |
| 5.1.2 DEVIATION FROM STANDARD | 20 |
| 5.1.3 TEST SETUP | 20 |
| 5.1.4 EUT OPERATION CONDITIONS | 20 |
| 5.1.5 EUT TEST CONDITIONS | 20 |
| 5.1.6 TEST RESULTS | 20 |
| 6 . AVERAGE TIME OF OCCUPANCY | 21 |

| Table of Contents | Page |
|---|-------------|
| 6.1 APPLIED PROCEDURES / LIMIT | 21 |
| 6.1.1 TEST PROCEDURE | 21 |
| 6.1.2 DEVIATION FROM STANDARD | 21 |
| 6.1.3 TEST SETUP | 21 |
| 6.1.4 EUT OPERATION CONDITIONS | 22 |
| 6.1.5 EUT TEST CONDITIONS | 22 |
| 6.1.6 TEST RESULTS | 22 |
| 7 . HOPPING CHANNEL SEPARATION MEASUREMENT | 23 |
| 7.1 APPLIED PROCEDURES / LIMIT | 23 |
| 7.1.1 TEST PROCEDURE | 23 |
| 7.1.2 DEVIATION FROM STANDARD | 23 |
| 7.1.3 TEST SETUP | 23 |
| 7.1.4 EUT TEST CONDITIONS | 23 |
| 7.1.5 TEST RESULTS | 23 |
| 8 . BANDWIDTH TEST | 24 |
| 8.1 APPLIED PROCEDURES | 24 |
| 8.1.1 TEST PROCEDURE | 24 |
| 8.1.2 DEVIATION FROM STANDARD | 24 |
| 8.1.3 TEST SETUP | 24 |
| 8.1.4 EUT OPERATION CONDITIONS | 24 |
| 8.1.5 EUT TEST CONDITIONS | 24 |
| 8.1.6 TEST RESULTS | 24 |
| 9 . PEAK OUTPUT POWER TEST | 25 |
| 9.1 APPLIED PROCEDURES / LIMIT | 25 |
| 9.1.1 TEST PROCEDURE | 25 |
| 9.1.2 DEVIATION FROM STANDARD | 25 |
| 9.1.3 TEST SETUP | 25 |
| 9.1.4 EUT OPERATION CONDITIONS | 25 |
| 9.1.5 EUT TEST CONDITIONS | 25 |
| 9.1.6 TEST RESULTS | 25 |
| 10 . ANTENNA CONDUCTED SPURIOUS EMISSION | 26 |
| 10.1 APPLIED PROCEDURES / LIMIT | 26 |
| 10.1.1 TEST PROCEDURE | 26 |
| 10.1.2 DEVIATION FROM STANDARD | 26 |
| 10.1.3 TEST SETUP | 26 |
| 10.1.4 EUT OPERATION CONDITIONS | 26 |
| 10.1.5 EUT TEST CONDITIONS | 26 |
| 10.1.6 TEST RESULTS | 26 |
| 11 . MEASUREMENT INSTRUMENTS LIST | 27 |
| 12 . EUT TEST PHOTO | 29 |

Table of Contents**Page**

| | |
|--|------------|
| APPENDIX A - CONDUCTED EMISSION | 33 |
| APPENDIX B - RADIATED EMISSION (9KHZ-30MHZ) | 36 |
| APPENDIX C - RADIATED EMISSION (30MHZ TO 1000MHZ) | 41 |
| APPENDIX D - RADIATED EMISSION (ABOVE 1000MHZ) | 48 |
| APPENDIX E - NUMBER OF HOPPING CHANNEL | 73 |
| APPENDIX F - AVERAGE TIME OF OCCUPANCY | 75 |
| APPENDIX G - HOPPING CHANNEL SEPARATION MEASUREMENT | 88 |
| APPENDIX H - BANDWIDTH | 93 |
| APPENDIX I - PEAK OUTPUT POWER | 98 |
| APPENDIX J - ANTENNA CONDUCTED SPURIOUS EMISSION | 103 |

REPORT ISSUED HISTORY

| Issued No. | Description | Issued Date |
|--------------------|-----------------|---------------|
| BTL-FCCP-1-1710179 | Original Issue. | Nov. 17, 2017 |

1. CERTIFICATION

Equipment : WIRELESS SPEAKER
Brand Name : 808
Model Name : SP201
Applicant : Voxx Accessories Corp.
Date of Test : Nov. 01, 2017 ~ Nov. 16, 2017
Test Sample : Engineering Sample
Standard(s) : FCC Part15, Subpart C (15.247)/ ANSI C63.10-2013

The above equipment has been tested and found compliance with the requirement of the relative standards by BTL Inc.

The test data, data evaluation, and equipment configuration contained in our test report (Ref No. BTL-FCCP-1-1710179) were obtained utilizing the test procedures, test instruments, test sites that has been accredited by the Authority of NVLAP according to the ISO-17025 quality assessment standard and technical standard(s).

2. SUMMARY OF TEST RESULTS

Test procedures according to the technical standard(s):

| Applied Standard(s): FCC Part15, Subpart C (15.247) | | | |
|---|-------------------------------------|----------|--------|
| Standard(s) Section | Test Item | Judgment | Remark |
| 15.207 | Conducted Emission | PASS | |
| 15.247(d) | Antenna conducted Spurious Emission | PASS | |
| 15.247 (a)(1) | Hopping Channel Separation | PASS | |
| 15.247(a)(1) | Bandwidth | PASS | |
| 15.247 (b)(1) | Peak Output Power | PASS | |
| 15.247(d) 15.209 | Radiated Spurious Emission | PASS | |
| 15.247 (a)(1)(iii) | Number of Hopping Frequency | PASS | |
| 15.247 (a)(1)(iii) | Dwell Time | PASS | |
| 15.205 | Restricted Bands | PASS | |
| 15.203 | Antenna Requirement | PASS | |

Note:

(1) "N/A" denotes test is not applicable in this test report

2.1 TEST FACILITY

The test facilities used to collect the test data in this report is at the location of No.3, Jinshagang 1st Road, Shixia, Dalang Town, Dongguan, Guangdong, China.

BTL's test firm number for FCC: 854385

BTL's designation number for FCC: CN5020

2.2 MEASUREMENT UNCERTAINTY

Where relevant, the following measurement uncertainty levels have been estimated for tests performed on the EUT as specified in CISPR 16-4-2. The measurement instrumentation uncertainty considerations contained in CISPR 16-4-2.

The reported uncertainty of measurement $y \pm U$, where expanded uncertainty U is based on a standard uncertainty multiplied by a coverage factor of $k=2$, providing a level of confidence of approximately **95** %.

A. Conducted Measurement :

| Test Site | Method | Measurement Frequency Range | U, (dB) |
|-----------|--------|-----------------------------|---------|
| DG-C02 | CISPR | 150 KHz ~ 30MHz | 2.32 |

B. Radiated Measurement :

| Test Site | Method | Measurement Frequency Range | Ant. H / V | U, (dB) |
|-----------|--------|-----------------------------|------------|---------|
| DG-CB03 | CISPR | 9KHz~30MHz | V | 3.79 |
| | | 9KHz~30MHz | H | 3.57 |
| | | 30MHz ~ 200MHz | V | 3.82 |
| | | 30MHz ~ 200MHz | H | 3.78 |
| | | 200MHz ~ 1,000MHz | V | 4.10 |
| | | 200MHz ~ 1,000MHz | H | 4.06 |
| | | 1GHz~18GHz | V | 3.12 |
| | | 1GHz~18GHz | H | 3.68 |
| | | 18GHz~40GHz | V | 4.15 |
| | | 18GHz~40GHz | H | 4.14 |

C. Other Measurement:

| Test Item | Uncertainty |
|-----------------------------|-------------|
| Conducted Spurious Emission | 2.67dB |
| Hopping Channel Separation | 53.46MHz |
| Peak Output Power | 0.95dB |
| Number of Hopping Frequency | 53.46MHz |
| Temperature | 0.08°C |
| Humidity | 1.5% |

Note: Unless specifically mentioned, the uncertainty of measurement has not been taken into account to declare the compliance or non-compliance to the specification.

3. GENERAL INFORMATION

3.1 GENERAL DESCRIPTION OF EUT

| | | |
|---------------------|---|--------------------------------------|
| Equipment | WIRELESS SPEAKER | |
| Brand Name | 808 | |
| Model Name | SP201 | |
| Model Difference | The SP201 comes in color variations but are electrically and mechanically the same. The only difference is the color. | |
| Output Power (Max.) | Operation Frequency | 2402~2480 MHz |
| | Modulation Technology | GFSK(1Mbps) π /4-DQPSK(2Mbps) |
| | Bit Rate of Transmitter | 8-DPSK(3Mbps) |
| | Output Power Max. | 2.59 dBm(1Mbps) 2.53 dBm(3Mbps) |
| Power Source | #1 DC voltage supplied from USB port. #2 Supplied from Li-ion battery. | |
| Power Rating | #1 DC 5V, 1A #2 DC 3.7V, 520mAh | |

Note:

1. For a more detailed features description, please refer to the manufacturer's specifications or the user's manual.

2. Channel List:

| Channel | Frequency (MHz) | Channel | Frequency (MHz) | Channel | Frequency (MHz) |
|---------|-----------------|---------|-----------------|---------|-----------------|
| 00 | 2402 | 27 | 2429 | 54 | 2456 |
| 01 | 2403 | 28 | 2430 | 55 | 2457 |
| 02 | 2404 | 29 | 2431 | 56 | 2458 |
| 03 | 2405 | 30 | 2432 | 57 | 2459 |
| 04 | 2406 | 31 | 2433 | 58 | 2460 |
| 05 | 2407 | 32 | 2434 | 59 | 2461 |
| 06 | 2408 | 33 | 2435 | 60 | 2462 |
| 07 | 2409 | 34 | 2436 | 61 | 2463 |
| 08 | 2410 | 35 | 2437 | 62 | 2464 |
| 09 | 2411 | 36 | 2438 | 63 | 2465 |
| 10 | 2412 | 37 | 2439 | 64 | 2466 |
| 11 | 2413 | 38 | 2440 | 65 | 2467 |
| 12 | 2414 | 39 | 2441 | 66 | 2468 |
| 13 | 2415 | 40 | 2442 | 67 | 2469 |
| 14 | 2416 | 41 | 2443 | 68 | 2470 |
| 15 | 2417 | 42 | 2444 | 69 | 2471 |
| 16 | 2418 | 43 | 2445 | 70 | 2472 |
| 17 | 2419 | 44 | 2446 | 71 | 2473 |
| 18 | 2420 | 45 | 2447 | 72 | 2474 |
| 19 | 2421 | 46 | 2448 | 73 | 2475 |
| 20 | 2422 | 47 | 2449 | 74 | 2476 |
| 21 | 2423 | 48 | 2450 | 75 | 2477 |
| 22 | 2424 | 49 | 2451 | 76 | 2478 |
| 23 | 2425 | 50 | 2452 | 77 | 2479 |
| 24 | 2426 | 51 | 2453 | 78 | 2480 |
| 25 | 2427 | 52 | 2454 | | |
| 26 | 2428 | 53 | 2455 | | |

3 Table for Filed Antenna:

| Ant. | Brand | Model Name | Antenna Type | Connector | Gain (dBi) |
|------|---------------------------|------------|--------------|-----------|------------|
| 1 | SHENZHENSIXI NZHONGXIN | F-6188 | PCB | N/A | 0 |

3.2 DESCRIPTION OF TEST MODES

To investigate the maximum EMI emission characteristics generates from EUT, the test system was pre-scanning tested base on the consideration of following EUT operation mode or test configuration mode which possible have effect on EMI emission level. Each of these EUT operation mode(s) or test configuration mode(s) mentioned above was evaluated respectively.

| Pretest Mode | Description |
|--------------|-------------------------|
| Mode 1 | TX Mode Note (1) |

The EUT system operated these modes were found to be the worst case during the pre-scanning test as following:

| For Conducted Emission | |
|------------------------|-------------|
| Final Test Mode | Description |
| Mode 1 | TX Mode |

| For Radiated Emission | |
|-----------------------|-------------------------|
| Final Test Mode | Description |
| Mode 1 | TX Mode Note (1) |

Note:

- (1) The measurements are performed at the high, middle, low available channels.
- (2) The measurements for Hopping Channel Separation, Bandwidth and Peak Output Power were tested during 1Mbps, 2Mbps and 3Mbps, the worst case are 1Mbps and 3Mbps, only worst case was documented.

3.3 TABLE OF PARAMETERS OF TEXT SOFTWARE SETTING

During testing, channel & power controlling software provided by the customer was used to control the operating channel as well as the output power level. The RF output power selection is for the setting of RF output power expected by the customer and is going to be fixed on the firmware of the final end product power parameters of FHSS

| Test Software Version | BK3256 RF Test_V1.3 | | |
|-----------------------|---------------------|----------|----------|
| Frequency | 2402 MHz | 2441 MHz | 2480 MHz |
| Parameters(1Mbps) | 3 | 3 | 3 |
| Parameters(3Mbps) | 3 | 3 | 3 |

3.4 BLOCK DIAGRAM SHOWING THE CONFIGURATION OF SYSTEM TESTED

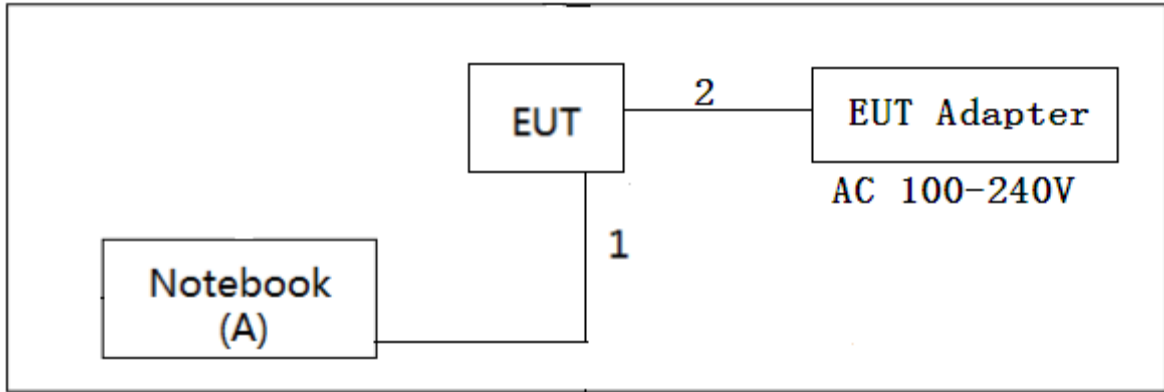

3.5 DESCRIPTION OF SUPPORT UNITS

The EUT has been tested as an independent unit together with other necessary accessories or support units. The following support units or accessories were used to form a representative test configuration during the tests.

| Item | Equipment | Mfr/Brand | Model/Type No. | FCC ID | Series No. |
|------|-----------|-----------|----------------|--------|------------|
| A | Notebook | DLEE | DLEE N4030 | DOC | GYHG9N1 |

| Item | Shielded Type | Ferrite Core | Length | Note |
|------|---------------|--------------|--------|-----------|
| 1 | NO | NO | 1m | USB Cable |
| 2 | NO | NO | 0.5m | DC Cable |

4. EMC EMISSION TEST

4.1 CONDUCTED EMISSION MEASUREMENT

4.1.1 POWER LINE CONDUCTED EMISSION LIMITS (Frequency Range 150KHz-30MHz)

| Frequency of Emission (MHz) | Conducted Limit (dB μ V) | |
|-----------------------------|------------------------------|-------------------|
| | Quasi-peak | Average \square |
| 0.15 -0.50 | 66 to 56* | 56 to 46* |
| 0.50 -5.0 | 56 | 46 |
| 5.0 -30.0 | 60 | 50 |

Note:

- (1) The limit of " * " decreases with the logarithm of the frequency
- (2) The test result calculated as following:
 Measurement Value = Reading Level + Correct Factor
 Correct Factor = Insertion Loss + Cable Loss + Attenuator Factor(if use)
 Margin Level = Measurement Value - Limit Value

The following table is the setting of the receiver

| Receiver Parameters | Setting |
|---------------------|----------|
| Attenuation | 10 dB |
| Start Frequency | 0.15 MHz |
| Stop Frequency | 30 MHz |
| IF Bandwidth | 9 KHz |

4.1.2 TEST PROCEDURE

- a. The EUT was placed 0.8 meters from the horizontal ground plane with EUT being connected to the power mains through a line impedance stabilization network (LISN). All other support equipment powered from additional LISN(s). The LISN provide 50 Ohm/ 50uH of coupling impedance for the measuring instrument.
- b. Interconnecting cables that hang closer than 40 cm to the ground plane shall be folded back and forth in the center forming a bundle 30 to 40 cm long.
- c. I/O cables that are not connected to a peripheral shall be bundled in the center. The end of the cable may be terminated, if required, using the correct terminating impedance. The overall length shall not exceed 1 m.
- d. LISN at least 80 cm from nearest part of EUT chassis.
- e. For the actual test configuration, please refer to the related Item –EUT Test Photos.

4.1.3 DEVIATION FROM TEST STANDARD

No deviation

4.1.4 TEST SETUP

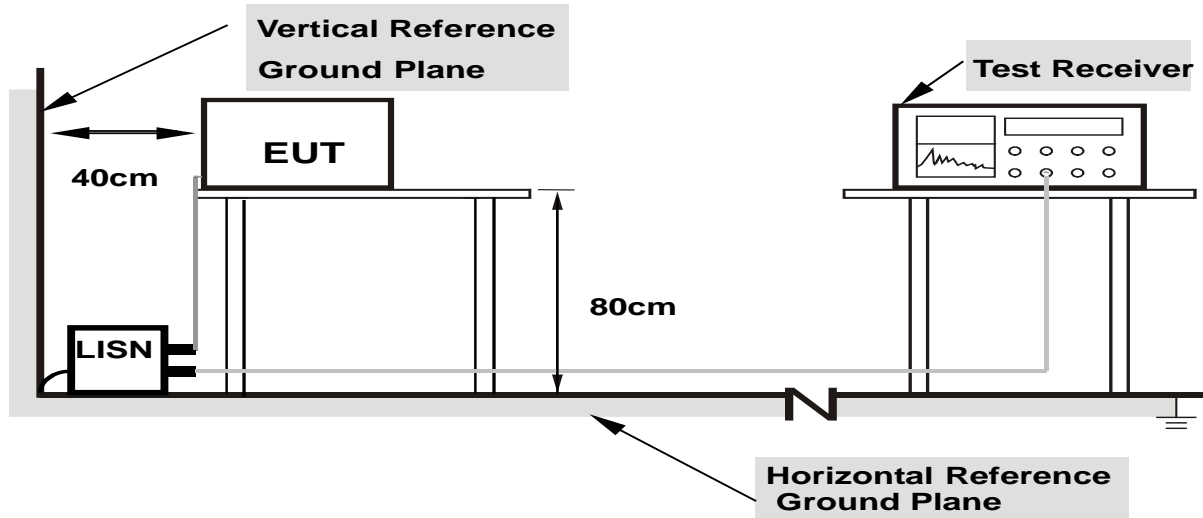

- Note:**
1. Support units were connected to second LISN.
 2. Both of LISNs (AMN) are 80 cm from EUT and at least 80 from other units and other metal planes

4.1.5 EUT OPERATING CONDITIONS

The EUT was configured for testing in a typical function (as a customer would normally use it), EUT was programmed to be in continuously transmitting/receiving data or hopping on mode.

4.1.6 EUT TEST CONDITIONS

Temperature: 25°C
 Relative Humidity: 55%
 Test Voltage: AC 120V/60Hz

4.1.7 TEST RESULTS

Please refer to the Appendix A.

Remark:

- (1) All readings are QP Mode value unless otherwise stated AVG in column of「Note」. If the QP Mode Measured value compliance with the QP Limits and lower than AVG Limits, the EUT shall be deemed to meet both QP & AVG Limits and then only QP Mode was measured, but AVG Mode didn't perform in this case, a "*" marked in AVG Mode column of Interference Voltage Measured.
- (2) Measuring frequency range from 150KHz to 30MHz.

4.2 RADIATED EMISSION MEASUREMENT

4.2.1 RADIATED EMISSION LIMITS (Frequency Range 9KHz -1000MHz)

In case the emission fall within the restricted band specified on 15.205(a), then the 15.209(a) limit in the table below has to be followed.

| Frequency (MHz) | Field Strength (microvolts/meter) | Measurement Distance (meters) |
|-----------------|-----------------------------------|-------------------------------|
| 0.009~0.490 | 2400/F(KHz) | 300 |
| 0.490~1.705 | 24000/F(KHz) | 30 |
| 1.705~30.0 | 30 | 30 |
| 30~88 | 100 | 3 |
| 88~216 | 150 | 3 |
| 216~960 | 200 | 3 |
| 960~1000 | 500 | 3 |

LIMITS OF RADIATED EMISSION MEASUREMENT (Above 1000MHz)

| Frequency (MHz) | (dBuV/m) (at 3 meters) | |
|-----------------|------------------------|---------|
| | PEAK | AVERAGE |
| Above 1000 | 74 | 54 |

Notes:

- (1) The limit for radiated test was performed according to FCC PART 15C.
- (2) The tighter limit applies at the band edges.
- (3) Emission level (dBuV/m)=20log Emission level (uV/m).
- (4) The test result calculated as following:
 Measurement Value = Reading Level + Correct Factor
 Correct Factor = Antenna Factor + Cable Loss - Amplifier Gain(if use)
 Margin Level = Measurement Value - Limit Value

LIMITS OF RADIATED EMISSION MEASUREMENT (Above 1000MHz)

| Spectrum Parameter | Setting |
|--|--|
| Attenuation | Auto |
| Start Frequency | 1000 MHz |
| Stop Frequency | 10th carrier harmonic |
| RBW / VBW (emission in restricted band) | 1 MHz / 1 MHz for Peak, 1 MHz / 10Hz for Average |

| Spectrum Receiver Parameter | Setting |
|-----------------------------|------------------------------------|
| Attenuation | Auto |
| Start ~ Stop Frequency | 9KHz ~90KHz for PK/AVG detector |
| Start ~ Stop Frequency | 90KHz ~110KHz for QP detector |
| Start ~ Stop Frequency | 110KHz ~490KHz for PK/AVG detector |
| Start ~ Stop Frequency | 490KHz ~30MHz for QP detector |
| Start ~ Stop Frequency | 30MHz~1000MHz for QP detector |

4.2.2 TEST PROCEDURE

- a. The measuring distance of 3 m shall be used for measurements. The EUT was placed on the top of a rotating table 0.8 meter above the ground at a 3 meter semi-anechoic chamber. The table was rotated 360 degrees to determine the position of the highest radiation.(below 1GHz)
- b. The measuring distance of 3 m shall be used for measurements. The EUT was placed on the top of a rotating table 1.5 meter above the ground at a 3 meter semi-anechoic chamber. The table was rotated 360 degrees to determine the position of the highest radiation.(above 1GHz)
- c. The height of the equipment or of the substitution antenna shall be 0.8m or 1.5m; the height of the test antenna shall vary between 1 m to 4 m. Both horizontal and vertical polarizations of the antenna are set to make the measurement.
- d. For each suspected emission, the EUT was arranged to its worst case and then the antenna was tuned to heights find the maximum reading (used Bore sight function).
- e. The receiver system was set to peak and average detect function and specified bandwidth with maximum hold mode when the test frequency is above 1GHz.
- f. The initial step in collecting radiated emission data is a receiver peak detector mode pre-scanning the measurement frequency range. Significant peaks are then marked and then Quasi Peak detector mode re-measured.
- g. All readings are Peak unless otherwise stated QP in column of Note. Peak denotes that the Peak reading compliance with the QP Limits and then QP Mode measurement didn't perform. (below 1GHz)
- h. All readings are Peak Mode value unless otherwise stated AVG in column of Note. If the Peak Mode Measured value compliance with the Peak Limits and lower than AVG Limits, the EUT shall be deemed to meet both Peak & AVG Limits and then only Peak Mode was measured, but AVG Mode didn't perform. (above 1GHz)
- i. For the actual test configuration, please refer to the related Item –EUT Test Photos.

4.2.3 DEVIATION FROM TEST STANDARD

No deviation

4.2.4 TEST SETUP

(A) Radiated Emission Test Set-Up Frequency Below 1 GHz

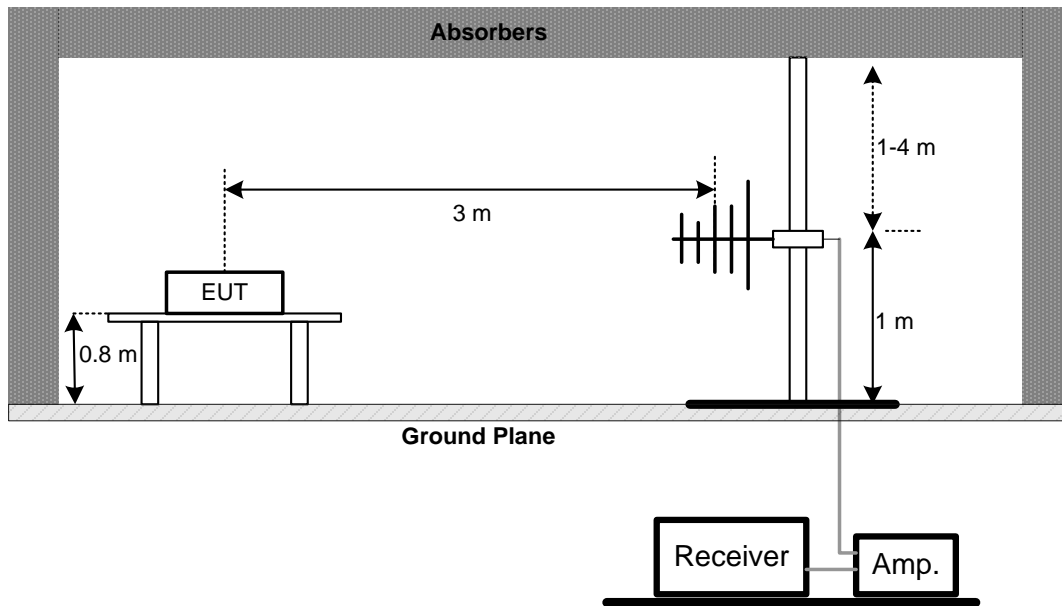

(B) Radiated Emission Test Set-Up Frequency Above 1 GHz

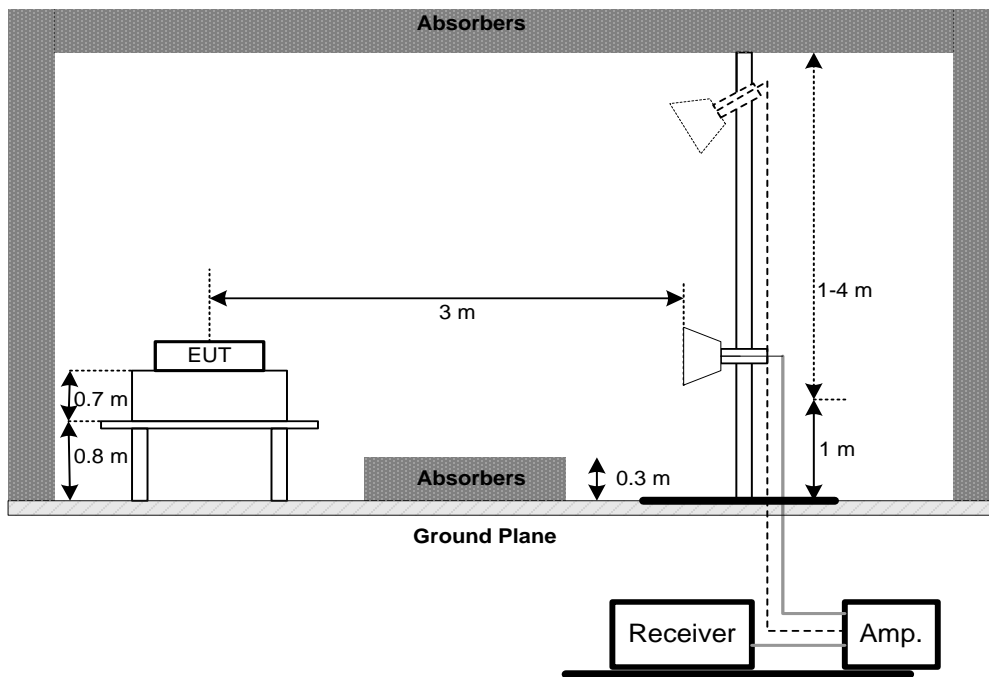

(C) For Radiated Emissions Below 30MHz

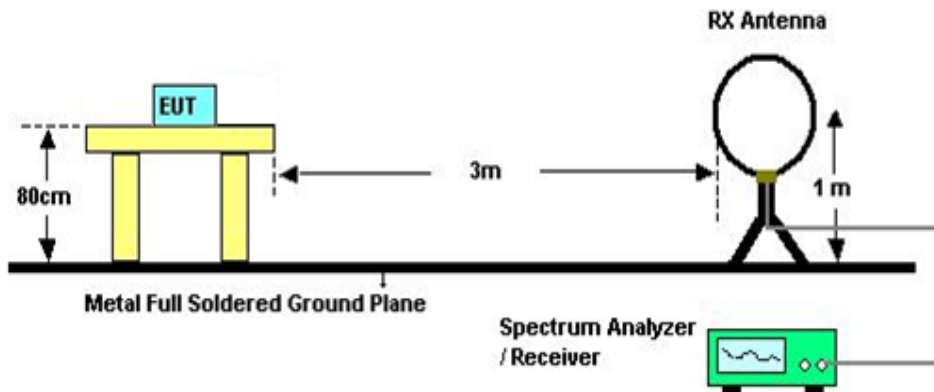

4.2.5 EUT OPERATING CONDITIONS

The EUT was programmed to be in continuously transmitting mode.

4.2.6 EUT TEST CONDITIONS

Temperature: 25°C

Relative Humidity: 55%

Test Voltage: AC 120V/60Hz

4.2.7 TEST RESULTS (9KHZ TO 30MHZ)

Please refer to the Appendix B

Remark:

- (1) The amplitude of spurious emissions which are attenuated by more than 20 dB below the permissible value has no need to be reported.
- (2) Distance extrapolation factor = $40 \log (\text{specific distance} / \text{test distance})$ (dB).
- (3) Limit line = specific limits (dBuV) + distance extrapolation factor.

4.2.8 TEST RESULTS (30MHZ TO 1000MHZ)

Please refer to the Appendix C.

4.2.9 TEST RESULTS (ABOVE 1000MHZ)

Please refer to the Appendix D.

Remark:

- (1) No limit: This is fundamental signal, the judgment is not applicable. For fundamental signal judgment was referred to Peak output test.

5. NUMBER OF HOPPING CHANNEL

5.1 APPLIED PROCEDURES

| FCC Part15 (15.247) , Subpart C | | | |
|---------------------------------|---------------------------|-----------------------|--------|
| Section | Test Item | Frequency Range (MHz) | Result |
| 15.247(a)(1)(iii) | Number of Hopping Channel | 2400-2483.5 | PASS |

| Spectrum Parameters | Setting |
|---------------------|-----------------------------|
| Attenuation | Auto |
| Span Frequency | > Operating Frequency Range |
| RBW | 100 KHz |
| VBW | 100 KHz |
| Detector | Peak |
| Trace | Max Hold |
| Sweep Time | Auto |

5.1.1 TEST PROCEDURE

- a. The EUT was directly connected to the spectrum analyzer and antenna output port as show in the block diagram below,
- b. Spectrum Setting: RBW=100KHz, VBW=100KHz, Sweep time = Auto.

5.1.2 DEVIATION FROM STANDARD

No deviation.

5.1.3 TEST SETUP

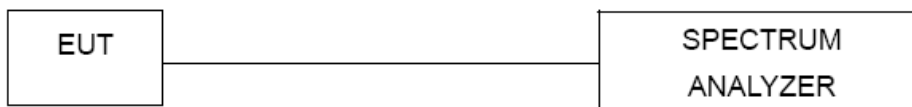

5.1.4 EUT OPERATION CONDITIONS

The EUT tested system was configured as the statements of 4.1.5 unless otherwise a special operating condition is specified in the follows during the testing.

5.1.5 EUT TEST CONDITIONS

Temperature: 25°C
 Relative Humidity: 55%
 Test Voltage: AC 120V/60Hz

5.1.6 TEST RESULTS

Please refer to the Appendix E

6. AVERAGE TIME OF OCCUPANCY

6.1 APPLIED PROCEDURES / LIMIT

| FCC Part15 (15.247) , Subpart C | | | | |
|---------------------------------|---------------------------|--------|-----------------------|--------|
| Section | Test Item | Limit | Frequency Range (MHz) | Result |
| 15.247(a)(1)(iii) | Average Time of Occupancy | 0.4sec | 2400-2483.5 | PASS |

6.1.1 TEST PROCEDURE

- a. The transmitter output (antenna port) was connected to the spectrum analyzer
- b. Set RBW of spectrum analyzer to 1MHz and VBW to 1MHz.
- c. Use a video trigger with the trigger level set to enable triggering only on full pulses.
- d. Sweep Time is more than once pulse time.
- e. Set the center frequency on any frequency would be measure and set the frequency span to zero span.
- f. Measure the maximum time duration of one single pulse.
- g. Set the EUT for DH5, DH3 and DH1 packet transmitting.
- h. Measure the maximum time duration of one single pulse.
 - i. DH5 Packet permit maximum $1600 / 79 / 6 = 3.37$ hops per second in each channel (5 time slots TX, 1 time slot RX). So, the dwell time is the time duration of the pulse times $3.37 \times 31.6 = 106.6$ within 31.6 seconds.
 - j. DH3 Packet permit maximum $1600 / 79 / 4 = 5.06$ hops per second in each channel (3 time slots TX, 1 time slot RX). So, the dwell time is the time duration of the pulse times $5.06 \times 31.6 = 160$ within 31.6 seconds.
 - k. DH1 Packet permit maximum $1600 / 79 / 2 = 10.12$ hops per second in each channel (1 time slot TX, 1 time slot RX). So, the dwell time is the time duration of the pulse times $10.12 \times 31.6 = 320$ within 31.6 seconds.

6.1.2 DEVIATION FROM STANDARD

No deviation.

6.1.3 TEST SETUP



6.1.4 EUT OPERATION CONDITIONS

The EUT tested system was configured as the statements of 4.1.5 unless otherwise a special operating condition is specified in the follows during the testing.

6.1.5 EUT TEST CONDITIONS

Temperature: 25°C

Relative Humidity: 55%

Test Voltage: AC 120V/60Hz

6.1.6 TEST RESULTS

Please refer to the Appendix F

7. HOPPING CHANNEL SEPARATION MEASUREMENT

7.1 APPLIED PROCEDURES / LIMIT

Frequency hopping systems operating in the 2400-2483.5 MHz band may have hopping channel carrier frequencies that are separated by 25 KHz or two-thirds of the 20 dB bandwidth of the hopping channel, whichever is greater.

| Spectrum Parameter | Setting |
|--------------------|---|
| Attenuation | Auto |
| Span Frequency | > Measurement Bandwidth or Channel Separation |
| RBW | 30 KHz |
| VBW | 100 KHz |
| Detector | Peak |
| Trace | Max Hold |
| Sweep Time | Auto |

7.1.1 TEST PROCEDURE

- a. The EUT must have its hopping function enabled
- b. Span = wide enough to capture the peaks of two adjacent channels
 Resolution (or IF) Bandwidth (RBW) \geq 1% of the span
 Video (or Average) Bandwidth (VBW) \geq RBW
 Sweep = Auto
 Detector function = Peak
 Trace = Max Hold

7.1.2 DEVIATION FROM STANDARD

No deviation.

7.1.3 TEST SETUP

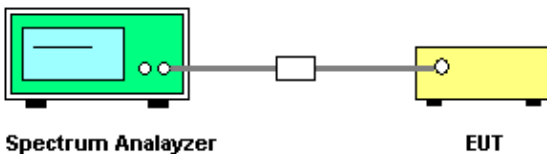

7.1.4 EUT TEST CONDITIONS

Temperature: 25°C
 Relative Humidity: 55%
 Test Voltage: AC 120V/60Hz

7.1.5 TEST RESULTS

Please refer to the Appendix G

8. BANDWIDTH TEST

8.1 APPLIED PROCEDURES

| FCC Part15 (15.247) , Subpart C | | |
|---------------------------------|-----------|-----------------------|
| Section | Test Item | Frequency Range (MHz) |
| 15.247(a)(2) | Bandwidth | 2400-2483.5 |

| Spectrum Parameter | Setting |
|--------------------|---|
| Attenuation | Auto |
| Span Frequency | > Measurement Bandwidth or Channel Separation |
| RBW | 30 KHz (20dB Bandwidth) / 30 KHz (Channel Separation) |
| VBW | 100 KHz (20dB Bandwidth) / 100 KHz (Channel Separation) |
| Detector | Peak |
| Trace | Max Hold |
| Sweep Time | Auto |

8.1.1 TEST PROCEDURE

- a. The EUT was directly connected to the spectrum analyzer and antenna output port as show in the block diagram below,
- b. Spectrum Setting: RBW= 30KHz, VBW=100KHz, Sweep Time = Auto.

8.1.2 DEVIATION FROM STANDARD

No deviation.

8.1.3 TEST SETUP



8.1.4 EUT OPERATION CONDITIONS

The EUT tested system was configured as the statements of 4.1.5 unless otherwise a special operating condition is specified in the follows during the testing.

8.1.5 EUT TEST CONDITIONS

Temperature: 25°C
 Relative Humidity: 55%
 Test Voltage: AC 120V/60Hz

8.1.6 TEST RESULTS

Please refer to the Appendix H

9. PEAK OUTPUT POWER TEST

9.1 APPLIED PROCEDURES / LIMIT

| FCC Part15 (15.247) , Subpart C | | | | |
|---------------------------------|-------------------|---|-----------------------|--------|
| Section | Test Item | Limit | Frequency Range (MHz) | Result |
| 15.247(b)(1) | Peak Output Power | 1 Watt or 30dBm (hopping channel >75) 0.125Watt or 21dBm (hopping channel <75 | 2400-2483.5 | PASS |

9.1.1 TEST PROCEDURE

- a. The EUT was directly connected to the spectrum analyzer and antenna output port as show in the block diagram below,
- b. Spectrum Setting: RBW= 1MHz/3MHz, VBW= 1MHz/3MHz, Sweep time = Auto.

9.1.2 DEVIATION FROM STANDARD

No deviation.

9.1.3 TEST SETUP

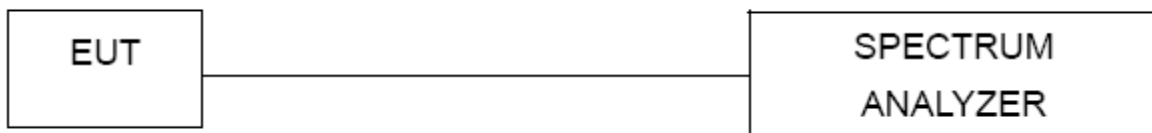

9.1.4 EUT OPERATION CONDITIONS

The EUT tested system was configured as the statements of 4.1.5 unless otherwise a special operating condition is specified in the follows during the testing.

9.1.5 EUT TEST CONDITIONS

Temperature: 25°C
Relative Humidity: 55%
Test Voltage: AC 120V/60Hz

9.1.6 TEST RESULTS

Please refer to the Appendix I

10. ANTENNA CONDUCTED SPURIOUS EMISSION

10.1 APPLIED PROCEDURES /LIMIT

In any 100 kHz bandwidth outside the frequency band in which the spread spectrum or digitally modulated device is operating, the RF power that is produced shall be at least 20 dB below that in the 100 kHz bandwidth within the band that contains the highest level of the desired power, based on either an RF conducted or a radiated measurement, provided that the transmitter demonstrates compliance with the peak conducted power limits.

10.1.1 TEST PROCEDURE

- a. The EUT was directly connected to the spectrum analyzer and antenna output port as show in the block diagram below,
- b. Spectrum Setting: RBW= 100KHz, VBW=100KHz, Sweep time = Auto.
- c. Offset=antenna gain+cable loss

10.1.2 DEVIATION FROM STANDARD

No deviation.

10.1.3 TEST SETUP



10.1.4 EUT OPERATION CONDITIONS

The EUT tested system was configured as the statements of 4.1.5 unless otherwise a special operating condition is specified in the follows during the testing.

10.1.5 EUT TEST CONDITIONS

Temperature: 25°C
 Relative Humidity: 55%
 Test Voltage: AC 120V/60Hz

10.1.6 TEST RESULTS

Please refer to the Appendix J

11. MEASUREMENT INSTRUMENTS LIST

| Conducted Emission Measurement | | | | | |
|--------------------------------|----------------------|--------------|-----------------------|------------|------------------|
| Item | Kind of Equipment | Manufacturer | Type No. | Serial No. | Calibrated until |
| 1 | EMI Test Receiver | R&S | ESCI | 100382 | Mar. 26, 2018 |
| 2 | LISN | EMCO | 3816/2 | 52765 | Mar. 26, 2018 |
| 3 | 50Ω Terminator | SHX | TF2-3G-A | 8122901 | Mar. 26, 2018 |
| 4 | TWO-LINE V-NETWORK | R&S | ENV216 | 101447 | Mar. 26, 2018 |
| 5 | Measurement Software | Farad | EZ-EMC Ver.NB-03A1-01 | N/A | N/A |
| 6 | Cable | N/A | RG223 | 12m | Oct. 19, 2018 |

| Radiated Emission Measurement - Below 1GHz | | | | | |
|--|----------------------|--------------|-----------------------------|-------------|------------------|
| Item | Kind of Equipment | Manufacturer | Type No. | Serial No. | Calibrated until |
| 1 | Antenna | Schwarbeck | VULB9160 | 9160-3232 | Mar. 26, 2018 |
| 2 | Amplifier | HP | 8447D | 2944A09673 | Oct. 19, 2018 |
| 3 | Receiver | Agilent | N9038A | MY52130039 | Aug. 20, 2018 |
| 4 | Cable | emci | LMR-400(30MHz-1 GHz)(8m+5m) | N/A | Jun. 26, 2018 |
| 5 | Controller | CT | SC100 | N/A | N/A |
| 6 | Controller | MF | MF-7802 | MF780208416 | N/A |
| 7 | Measurement Software | Farad | EZ-EMC Ver.NB-03A1-01 | N/A | N/A |

| Radiated Emission Measurement - Above 1GHz | | | | | |
|--|-------------------------------------|----------------|--------------------------|---------------|------------------|
| Item | Kind of Equipment | Manufacturer | Type No. | Serial No. | Calibrated until |
| 1 | Double Ridged Guide Antenna | ETS | 3115 | 75789 | Mar. 26, 2018 |
| 2 | Broad-Band Horn Antenna | Schwarzbeck | BBHA 9170 | 9170319 | Jun. 08, 2018 |
| 3 | Amplifier | Agilent | 8449B | 3008A02274 | May. 16, 2018 |
| 4 | Microwave Preamplifier With Adaptor | EMC INSTRUMENT | EMC2654045 | 980039 & HA01 | Mar. 26, 2018 |
| 5 | Receiver | Agilent | N9038A | MY52130039 | Aug. 20, 2018 |
| 6 | Antenna | EM | EM-6876-1 | 230 | Mar. 06, 2018 |
| 7 | Controller | CT | SC100 | N/A | N/A |
| 8 | Controller | MF | MF-7802 | MF780208416 | N/A |
| 9 | Cable | emci | EMC104-SM-SM-1 2000(12m) | N/A | Jun. 26, 2018 |
| 10 | Measurement Software | Farad | EZ-EMC Ver.NB-03A1-01 | N/A | N/A |

Number of Hopping Channel

| Item | Kind of Equipment | Manufacturer | Type No. | Serial No. | Calibrated until |
|------|-------------------|--------------|----------|------------|------------------|
| 1 | Spectrum Analyzer | R&S | FSP40 | 100185 | Aug. 20, 2018 |

Average Time of Occupancy

| Item | Kind of Equipment | Manufacturer | Type No. | Serial No. | Calibrated until |
|------|-------------------|--------------|----------|------------|------------------|
| 1 | Spectrum Analyzer | R&S | FSP40 | 100185 | Aug. 20, 2018 |

Hopping Channel Separation Measurement

| Item | Kind of Equipment | Manufacturer | Type No. | Serial No. | Calibrated until |
|------|-------------------|--------------|----------|------------|------------------|
| 1 | Spectrum Analyzer | R&S | FSP40 | 100185 | Aug. 20, 2018 |

Bandwidth

| Item | Kind of Equipment | Manufacturer | Type No. | Serial No. | Calibrated until |
|------|-------------------|--------------|----------|------------|------------------|
| 1 | Spectrum Analyzer | R&S | FSP40 | 100185 | Aug. 20, 2018 |

Peak Output Power

| Item | Kind of Equipment | Manufacturer | Type No. | Serial No. | Calibrated until |
|------|--------------------|--------------|----------|------------|------------------|
| 1 | Power Meter | ANRITSU | ML2495A | 1128009 | Mar. 26, 2018 |
| 2 | Pulse Power Sensor | ANRITSU | MA 2411B | 1027500 | Mar. 26, 2018 |

Antenna Conducted Spurious Emission

| Item | Kind of Equipment | Manufacturer | Type No. | Serial No. | Calibrated until |
|------|-------------------|--------------|----------|------------|------------------|
| 1 | Spectrum Analyzer | R&S | FSP40 | 100185 | Aug. 20, 2018 |

Remark: "N/A" denotes no model name, serial no. or calibration specified.
 All calibration period of equipment list is one year.

12. EUT TEST PHOTO

Conducted Measurement Photos



Radiated Measurement Photos

9KHz to 30MHz



Radiated Measurement Photos

30MHz to 1000MHz



Radiated Measurement Photos

Above 1000MHz

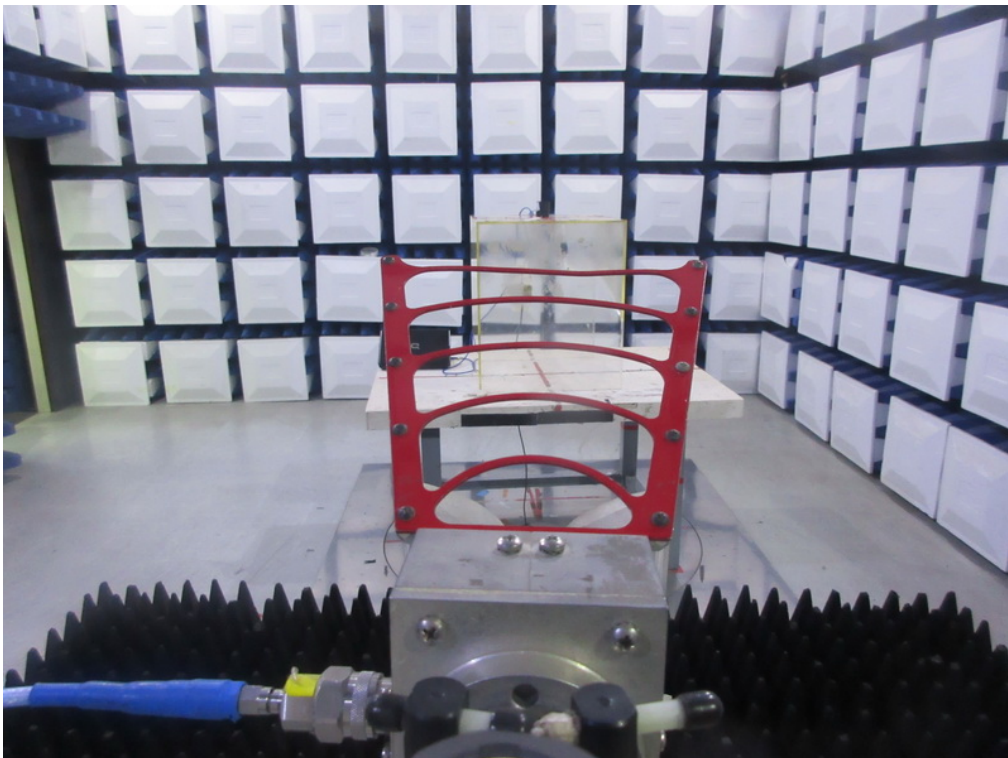
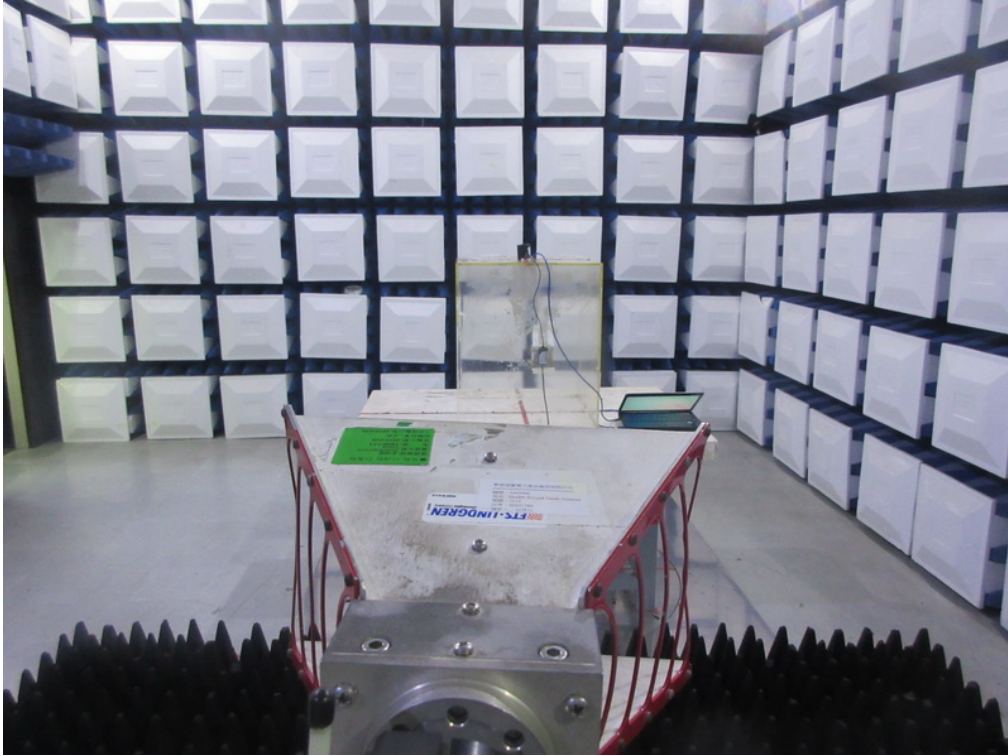

APPENDIX A - CONDUCTED EMISSION

Test Mode: TX Mode

Line

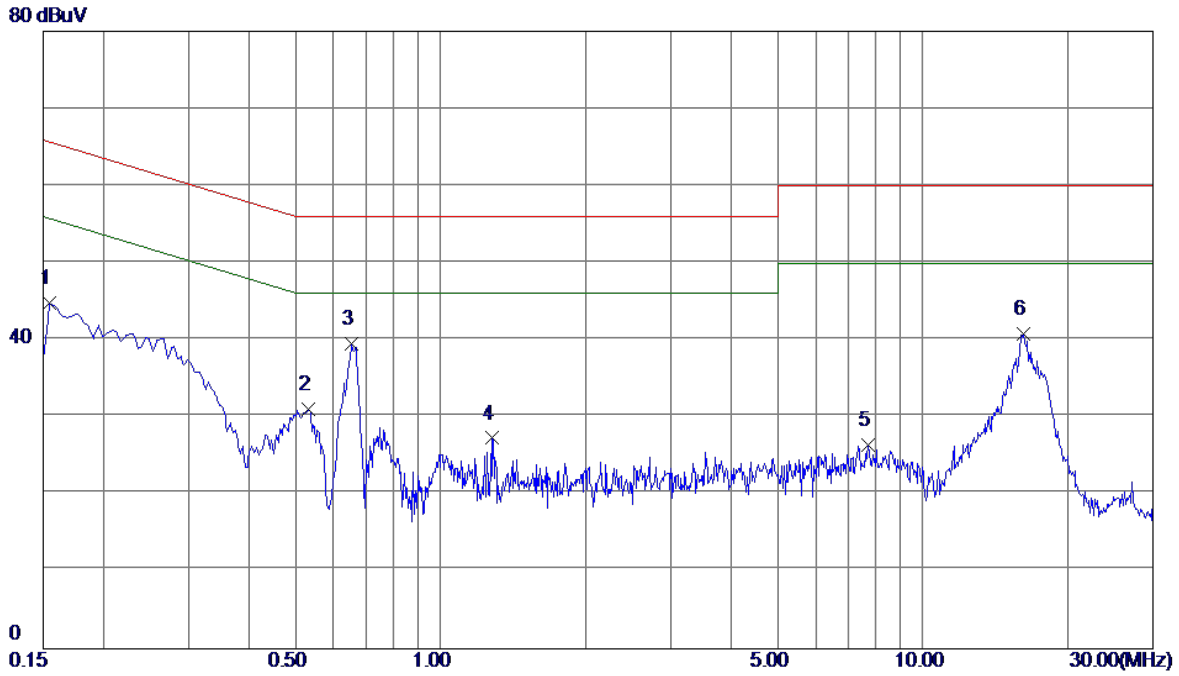

| No. | Freq. MHz | Reading Level dBuV | Correct Factor dB | Measurement dBuV | Limit dBuV | Margin dB | Detector | Comment |
|-----|-----------|--------------------|-------------------|------------------|------------|-----------|----------|---------|
| 1 | 0.1545 | 34.97 | 9.79 | 44.76 | 65.75 | -20.99 | Peak | |
| 2 | 0.5325 | 21.20 | 9.80 | 31.00 | 56.00 | -25.00 | Peak | |
| 3 * | 0.6540 | 29.76 | 9.82 | 39.58 | 56.00 | -16.42 | Peak | |
| 4 | 1.2750 | 17.40 | 9.88 | 27.28 | 56.00 | -28.72 | Peak | |
| 5 | 7.6965 | 16.22 | 10.22 | 26.44 | 60.00 | -33.56 | Peak | |
| 6 | 16.2150 | 30.17 | 10.61 | 40.78 | 60.00 | -19.22 | Peak | |

Test Mode: TX Mode

Neutral

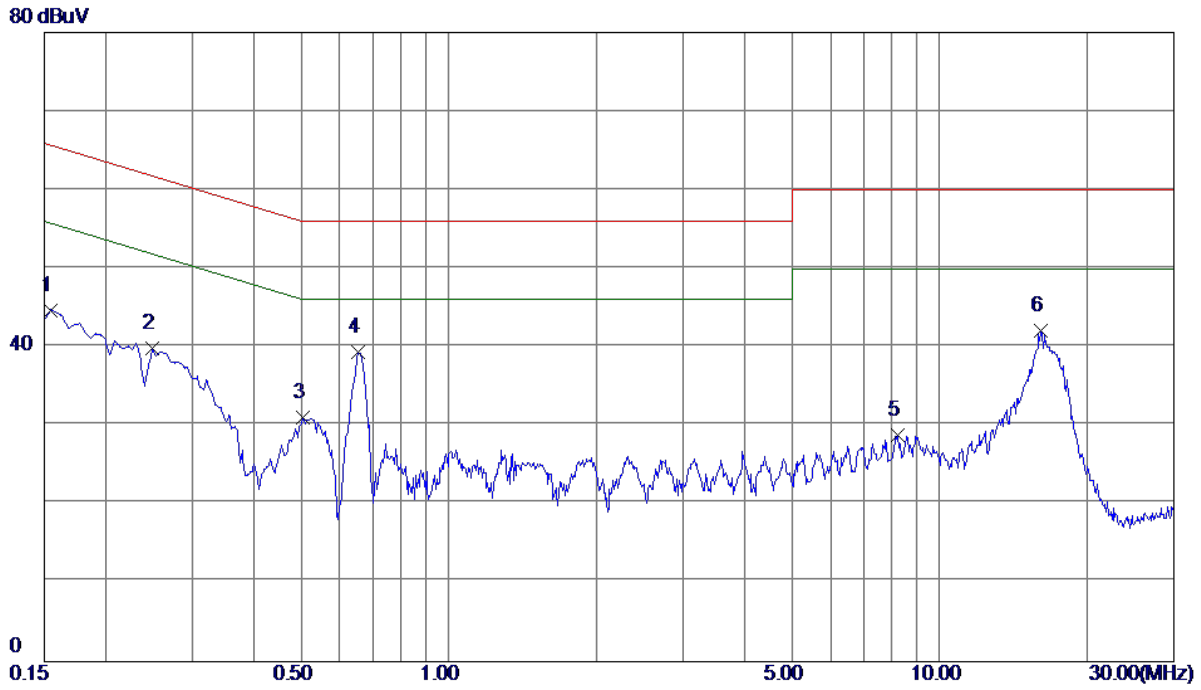

| No. | Freq. MHz | Reading Level dBuV | Correct Factor dB | Measure ment dBuV | Limit dBuV | Margin dB | Detector | Comment |
|-----|--------------|--------------------------|-------------------------|-------------------------|---------------|--------------|----------|---------|
| 1 | 0.1548 | 35.03 | 9.68 | 44.71 | 65.74 | -21.03 | Peak | |
| 2 | 0.2490 | 30.16 | 9.67 | 39.83 | 61.79 | -21.96 | Peak | |
| 3 | 0.5055 | 21.30 | 9.70 | 31.00 | 56.00 | -25.00 | Peak | |
| 4 * | 0.6540 | 29.60 | 9.72 | 39.32 | 56.00 | -16.68 | Peak | |
| 5 | 8.2050 | 18.59 | 10.17 | 28.76 | 60.00 | -31.24 | Peak | |
| 6 | 16.0665 | 31.39 | 10.66 | 42.05 | 60.00 | -17.95 | Peak | |

APPENDIX B - RADIATED EMISSION (9KHZ-30MHZ)

Test Mode: TX Mode

Ant 0°

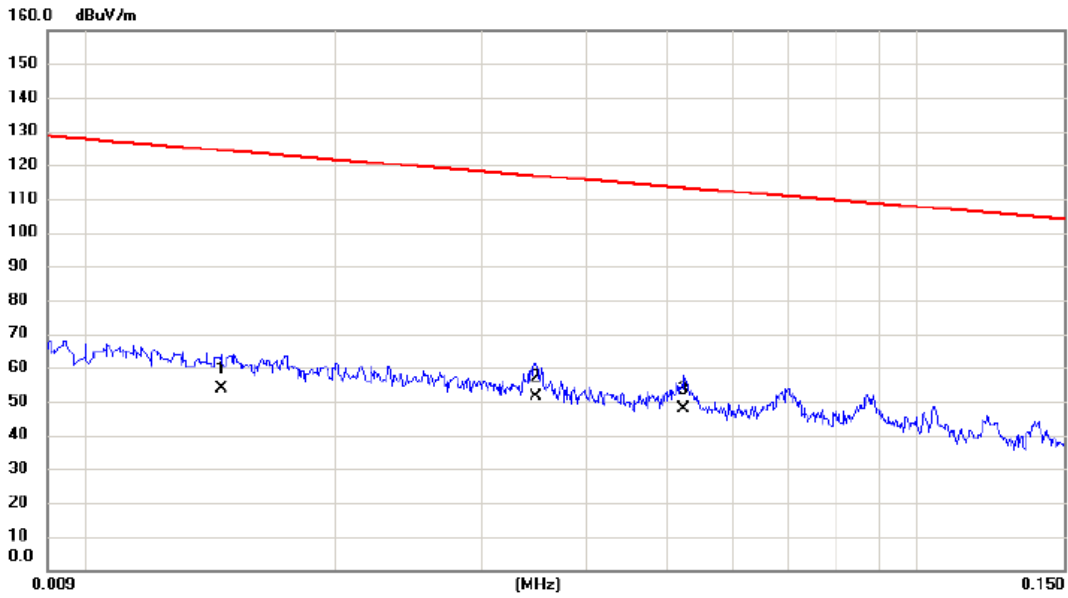

| No. | Mk. | Freq. MHz | Reading Level dBuV | Correct Factor dB | Measure- ment dBuV/m | Limit dBuV/m | Margin dB | Detector | Comment |
|-----|-----|--------------|--------------------------|-------------------------|----------------------------|-----------------|--------------|----------|---------|
| 1 | | 0.0146 | 33.67 | 20.32 | 53.99 | 124.32 | -70.33 | AVG | |
| 2 | | 0.0348 | 32.12 | 19.18 | 51.30 | 116.77 | -65.47 | AVG | |
| 3 | * | 0.0524 | 29.08 | 18.67 | 47.75 | 113.22 | -65.47 | AVG | |

Test Mode: TX Mode

Ant 0°

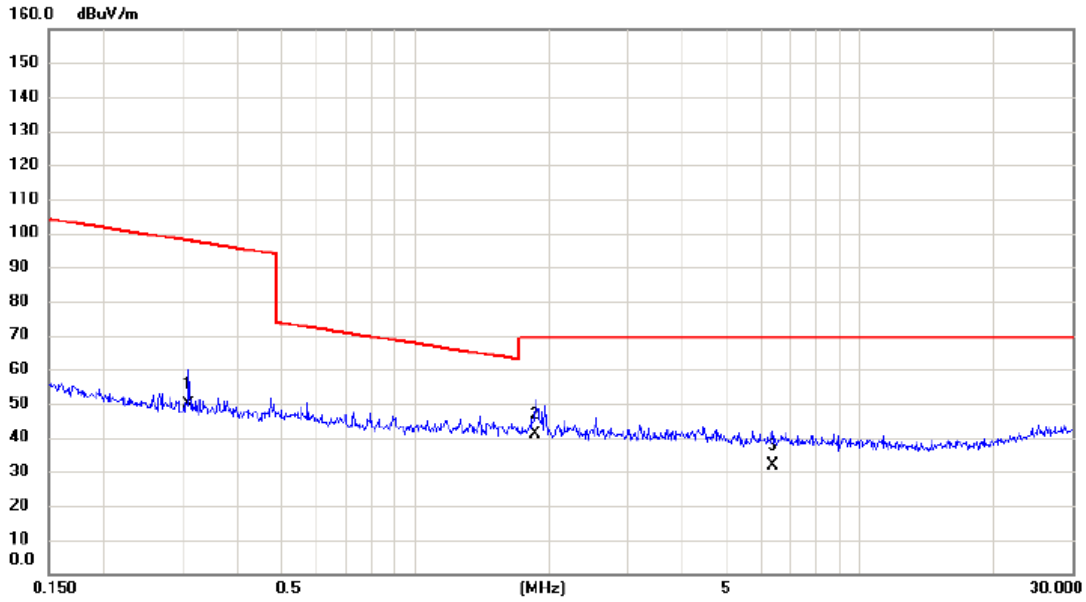

| No. | Mk. | Freq. MHz | Reading Level dBuV | Correct Factor dB | Measure- ment dBuV/m | Limit dBuV/m | Margin dB | Detector | Comment |
|-----|-----|--------------|--------------------------|-------------------------|----------------------------|-----------------|--------------|----------|---------|
| 1 | | 0.3100 | 33.16 | 16.61 | 49.77 | 97.78 | -48.01 | AVG | |
| 2 | * | 1.8581 | 25.62 | 15.57 | 41.19 | 69.54 | -28.35 | QP | |
| 3 | | 6.3520 | 17.70 | 14.20 | 31.90 | 69.54 | -37.64 | QP | |

Test Mode: TX Mode

Ant 90°

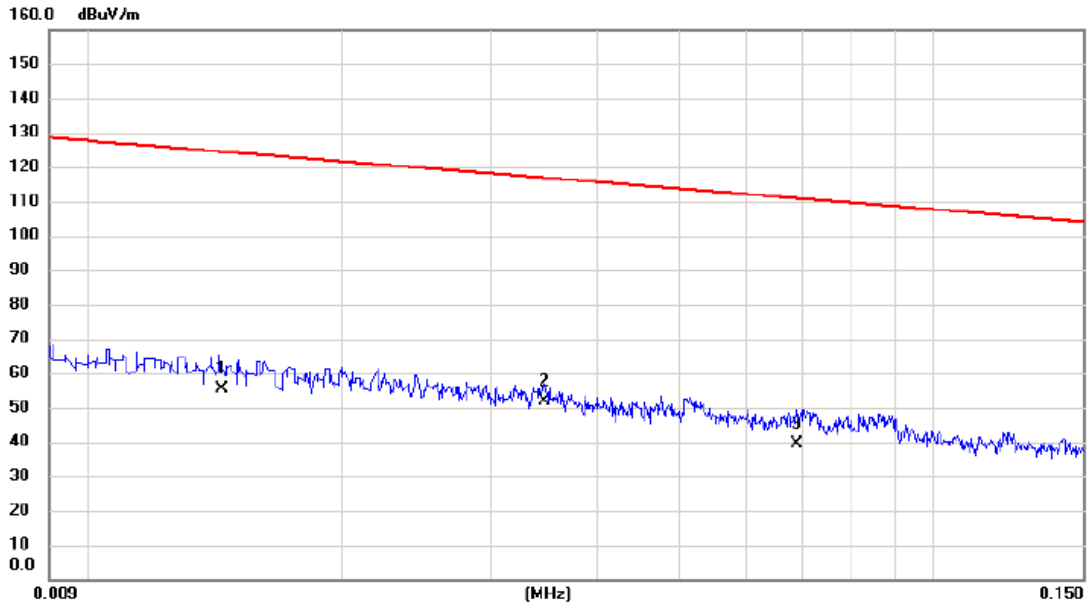

| No. | Mk. | Freq. MHz | Reading Level dBuV | Correct Factor dB | Measure- ment dBuV/m | Limit dBuV/m | Margin dB | Detector | Comment |
|-----|-----|--------------|--------------------------|-------------------------|----------------------------|-----------------|--------------|----------|---------|
| 1 | | 0.0144 | 35.14 | 20.35 | 55.49 | 124.44 | -68.95 | AVG | |
| 2 | * | 0.0347 | 32.74 | 19.18 | 51.92 | 116.80 | -64.88 | AVG | |
| 3 | | 0.0690 | 21.08 | 18.35 | 39.43 | 110.83 | -71.40 | AVG | |

Test Mode: TX Mode

Ant 90°

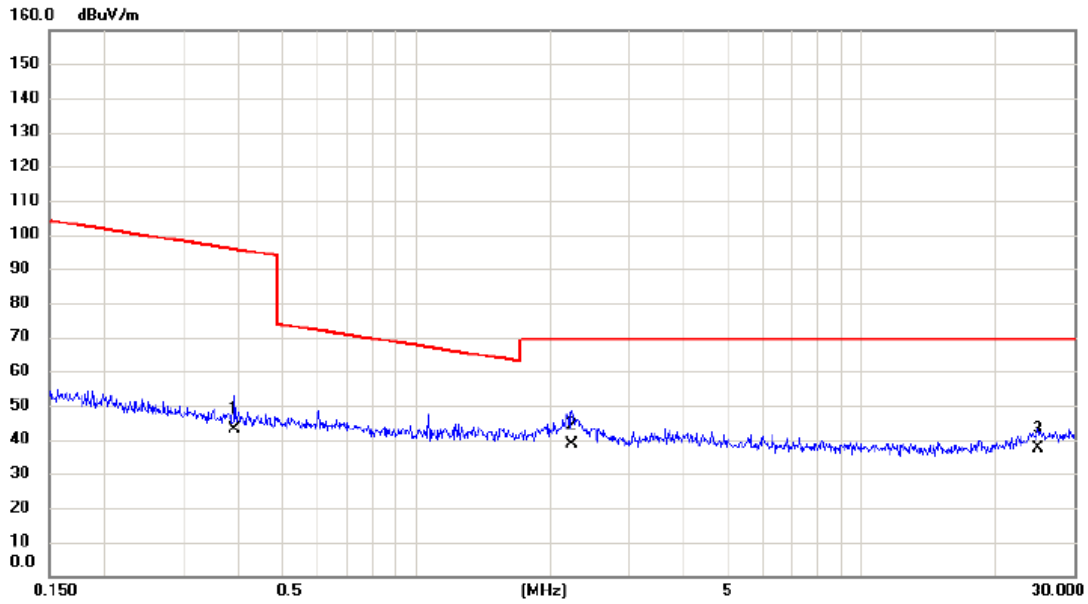

| No. | Mk. | Freq. MHz | Reading Level dBuV | Correct Factor dB | Measure- ment dBuV/m | Limit dBuV/m | Margin dB | Detector | Comment |
|-----|-----|--------------|--------------------------|-------------------------|----------------------------|-----------------|--------------|----------|---------|
| 1 | | 0.3914 | 26.28 | 16.55 | 42.83 | 95.75 | -52.92 | AVG | |
| 2 | * | 2.2367 | 23.11 | 15.44 | 38.55 | 69.54 | -30.99 | QP | |
| 3 | | 24.9221 | 17.72 | 19.64 | 37.36 | 69.54 | -32.18 | QP | |

APPENDIX C - RADIATED EMISSION (30MHZ TO 1000MHZ)

Test Mode: TX 2402MHz _CH00_1Mbps

Vertical

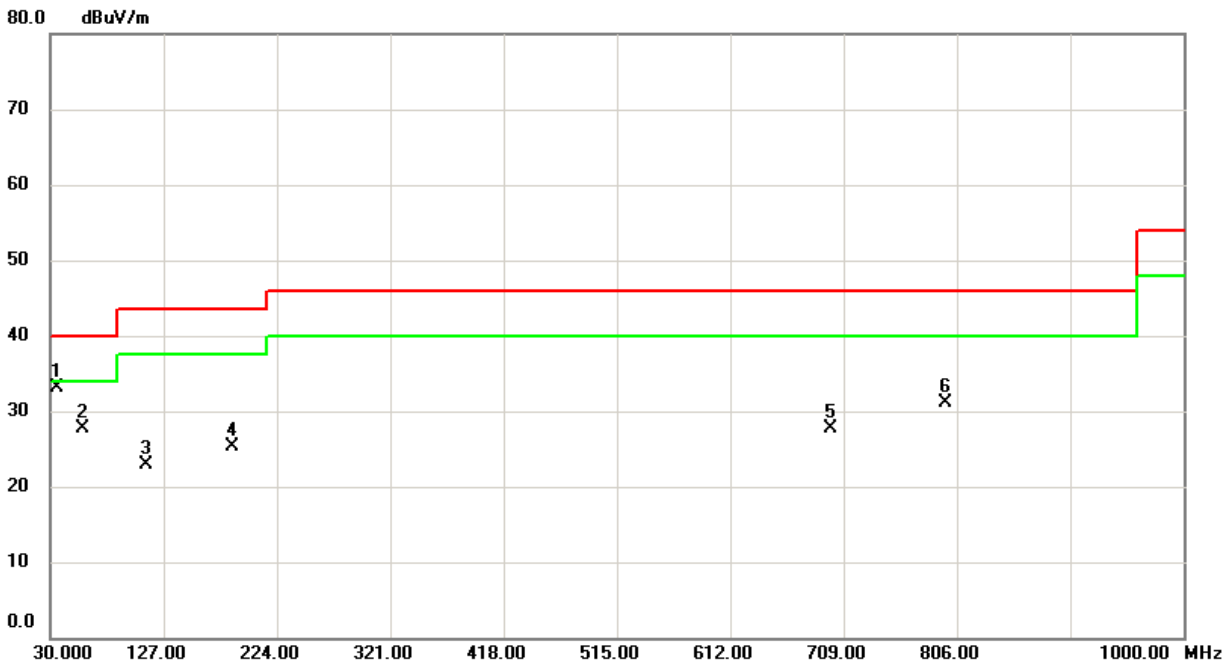

| No. | Freq. MHz | Reading Level dBuV/m | Correct Factor dB | Measurement dBuV/m | Limit dBuV/m | Margin dB | Detector | Comment |
|-----|-----------|----------------------|-------------------|--------------------|--------------|-----------|----------|---------|
| 1 * | 35.8200 | 47.69 | -14.51 | 33.18 | 40.00 | -6.82 | Peak | |
| 2 | 57.1600 | 41.73 | -14.04 | 27.69 | 40.00 | -12.31 | Peak | |
| 3 | 111.4800 | 38.95 | -16.07 | 22.88 | 43.50 | -20.62 | Peak | |
| 4 | 186.1700 | 37.88 | -12.54 | 25.34 | 43.50 | -18.16 | Peak | |
| 5 | 697.3600 | 31.67 | -4.02 | 27.65 | 46.00 | -18.35 | Peak | |
| 6 | 796.3000 | 32.47 | -1.44 | 31.03 | 46.00 | -14.97 | Peak | |

Test Mode: TX 2402MHz _CH00_1Mbps

Horizontal

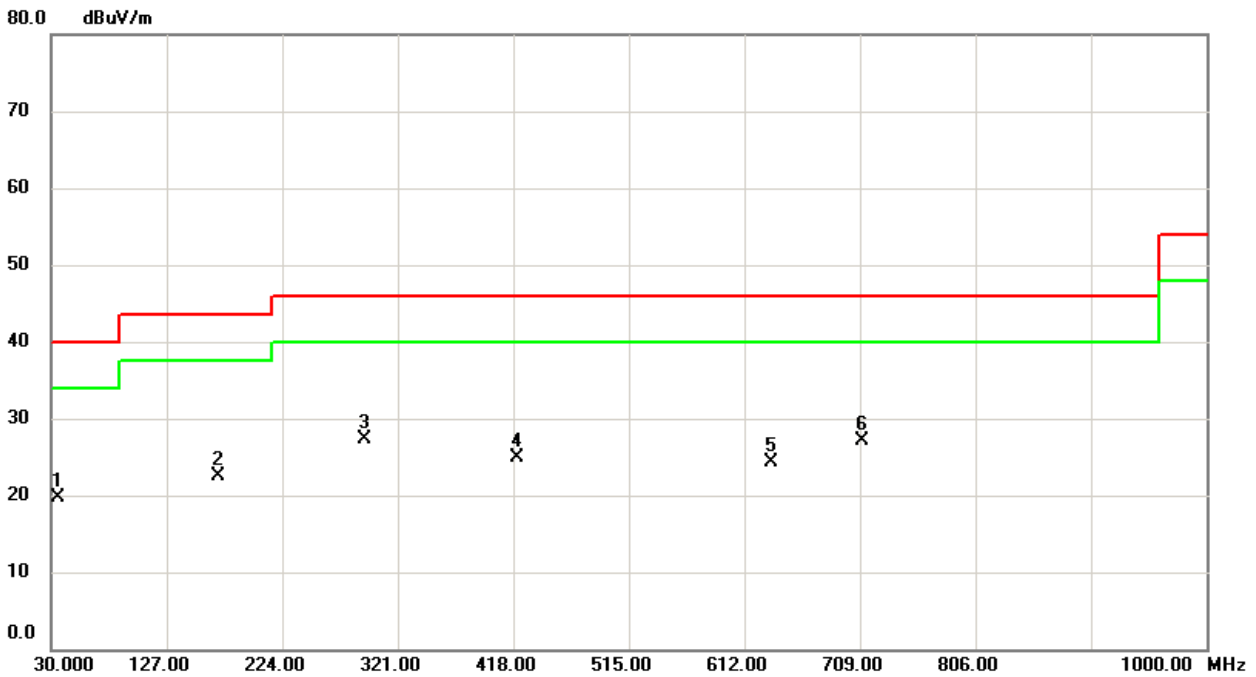

| No. | Freq. MHz | Reading Level dBuV/m | Correct Factor dB | Measure ment dBuV/m | Limit dBuV/m | Margin dB | Detector | Comment |
|-----|--------------|----------------------------|-------------------------|---------------------------|-----------------|--------------|----------|---------|
| 1 | 35.8200 | 34.19 | -14.51 | 19.68 | 40.00 | -20.32 | Peak | |
| 2 | 170.6500 | 34.81 | -12.32 | 22.49 | 43.50 | -21.01 | Peak | |
| 3 * | 293.8400 | 40.97 | -13.67 | 27.30 | 46.00 | -18.70 | Peak | |
| 4 | 420.9100 | 35.68 | -10.77 | 24.91 | 46.00 | -21.09 | Peak | |
| 5 | 634.3100 | 30.09 | -5.77 | 24.32 | 46.00 | -21.68 | Peak | |
| 6 | 710.9400 | 30.68 | -3.61 | 27.07 | 46.00 | -18.93 | Peak | |

Test Mode: TX 2441MHz _CH39_1Mbps

Vertical

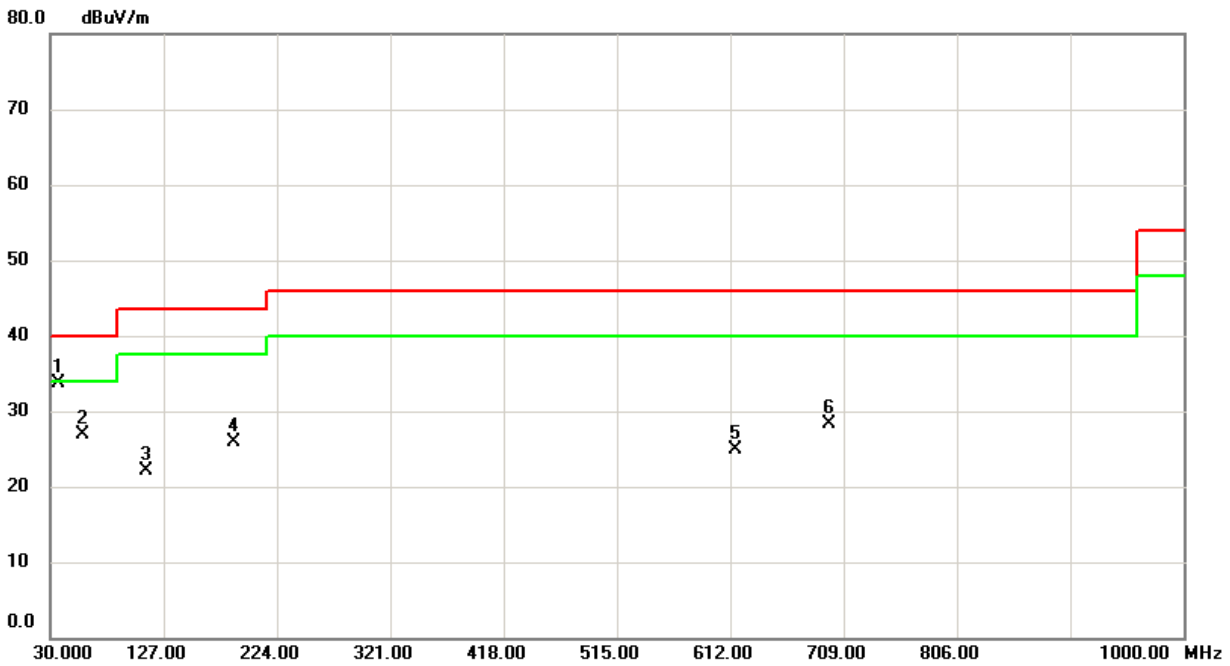

| No. | Freq. MHz | Reading Level dBuV/m | Correct Factor dB | Measurement dBuV/m | Limit dBuV/m | Margin dB | Detector | Comment |
|-----|-----------|----------------------|-------------------|--------------------|--------------|-----------|----------|---------|
| 1 * | 36.7900 | 48.21 | -14.41 | 33.80 | 40.00 | -6.20 | Peak | |
| 2 | 57.1600 | 40.94 | -14.04 | 26.90 | 40.00 | -13.10 | Peak | |
| 3 | 111.4800 | 38.21 | -16.07 | 22.14 | 43.50 | -21.36 | Peak | |
| 4 | 187.1400 | 38.46 | -12.61 | 25.85 | 43.50 | -17.65 | Peak | |
| 5 | 615.8800 | 31.10 | -6.12 | 24.98 | 46.00 | -21.02 | Peak | |
| 6 | 696.3900 | 32.30 | -4.05 | 28.25 | 46.00 | -17.75 | Peak | |

Test Mode: TX 2441MHz _CH39_1Mbps

Horizontal

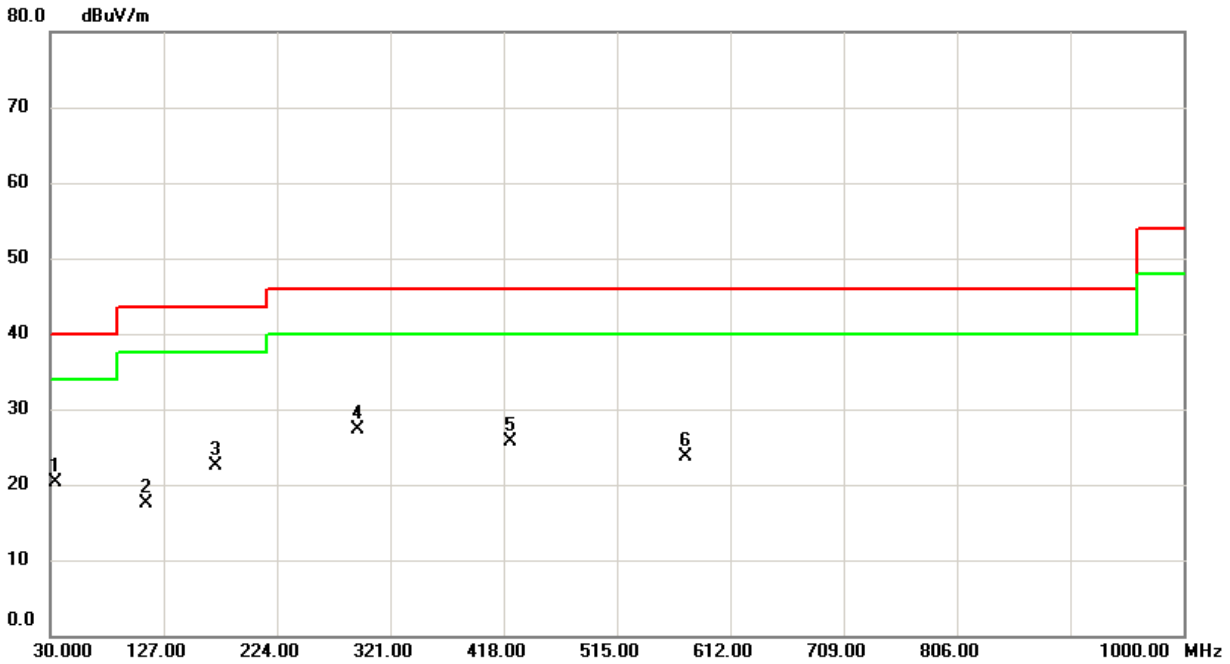

| No. | Freq. MHz | Reading Level dBuV/m | Correct Factor dB | Measure ment dBuV/m | Limit dBuV/m | Margin dB | Detector | Comment |
|-----|--------------|----------------------------|-------------------------|---------------------------|-----------------|--------------|----------|---------|
| 1 | 33.8800 | 35.08 | -14.73 | 20.35 | 40.00 | -19.65 | Peak | |
| 2 | 112.4500 | 33.42 | -16.00 | 17.42 | 43.50 | -26.08 | Peak | |
| 3 | 171.6200 | 34.86 | -12.29 | 22.57 | 43.50 | -20.93 | Peak | |
| 4 * | 292.8700 | 41.04 | -13.81 | 27.23 | 46.00 | -18.77 | Peak | |
| 5 | 423.8200 | 36.41 | -10.68 | 25.73 | 46.00 | -20.27 | Peak | |
| 6 | 573.2000 | 30.82 | -7.11 | 23.71 | 46.00 | -22.29 | Peak | |

Test Mode: TX 2480MHz _CH78_1Mbps

Vertical

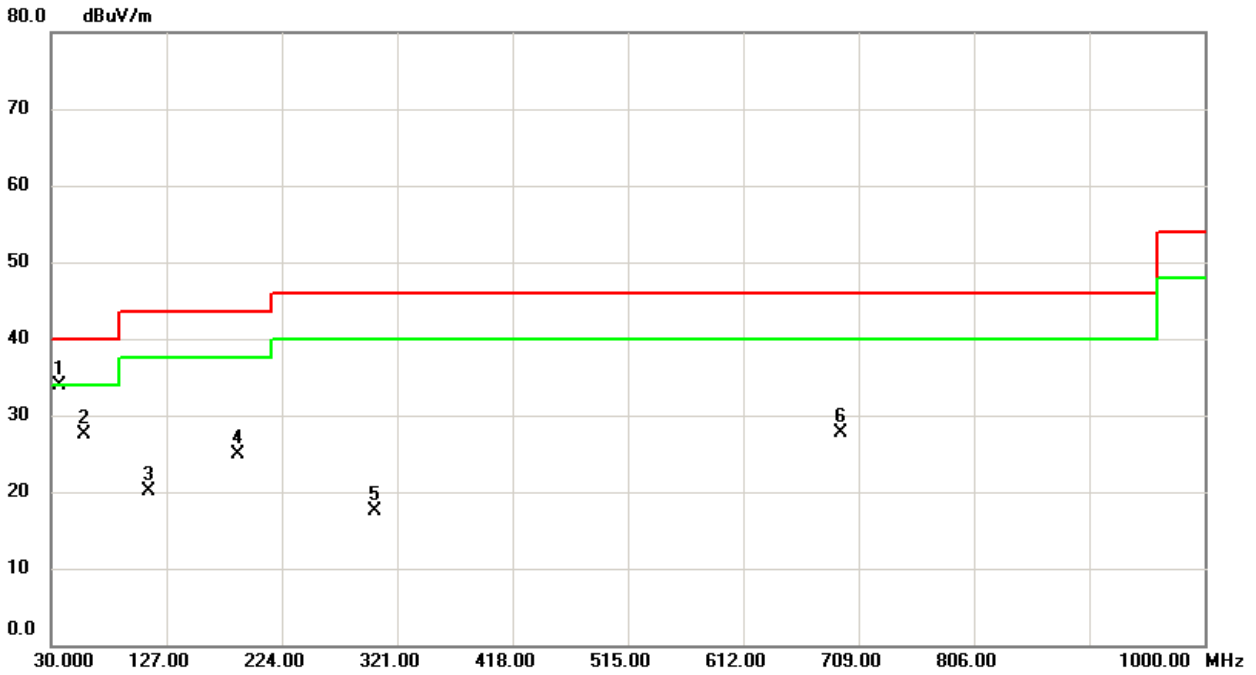

| No. | Freq. MHz | Reading Level dBuV/m | Correct Factor dB | Measure ment dBuV/m | Limit dBuV/m | Margin dB | Detector | Comment |
|-----|--------------|----------------------------|-------------------------|---------------------------|-----------------|--------------|----------|---------|
| 1 * | 36.7900 | 48.32 | -14.41 | 33.91 | 40.00 | -6.09 | Peak | |
| 2 | 57.1600 | 41.55 | -14.04 | 27.51 | 40.00 | -12.49 | Peak | |
| 3 | 111.4800 | 36.18 | -16.07 | 20.11 | 43.50 | -23.39 | Peak | |
| 4 | 187.1400 | 37.47 | -12.61 | 24.86 | 43.50 | -18.64 | Peak | |
| 5 | 302.5700 | 30.30 | -12.78 | 17.52 | 46.00 | -28.48 | Peak | |
| 6 | 693.4800 | 31.94 | -4.14 | 27.80 | 46.00 | -18.20 | Peak | |

Test Mode: TX 2480MHz _CH78_1Mbps

Horizontal

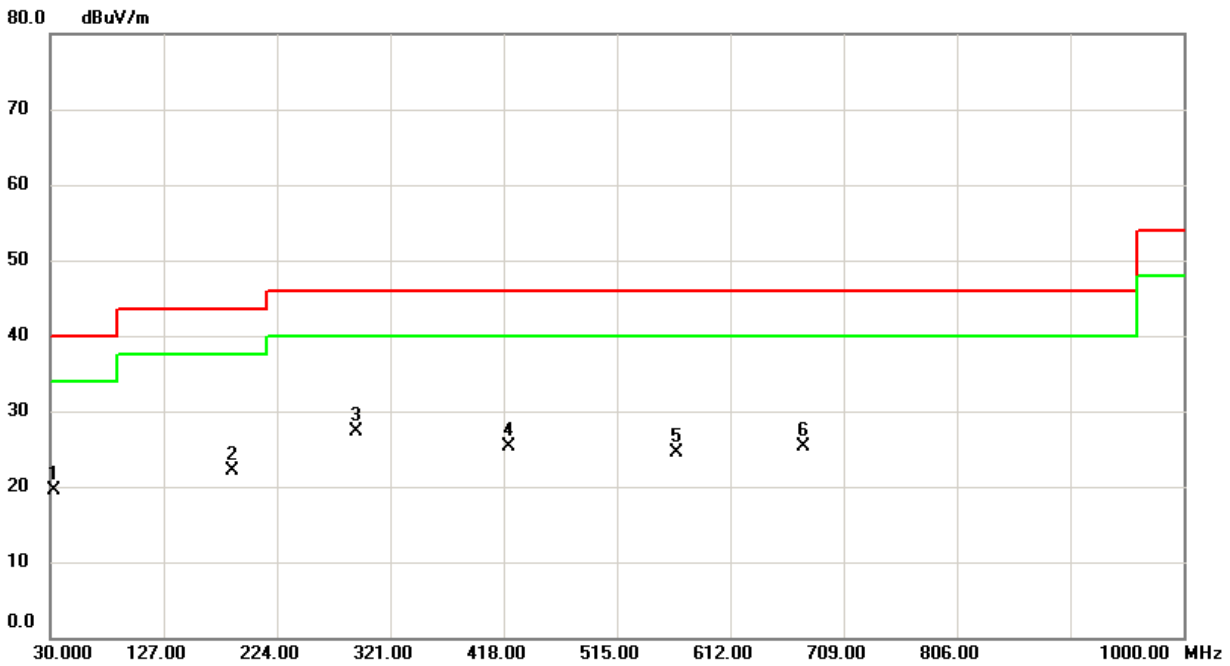

| No. | Freq. MHz | Reading Level dBuV/m | Correct Factor dB | Measure ment dBuV/m | Limit dBuV/m | Margin dB | Detector | Comment |
|-----|--------------|----------------------------|-------------------------|---------------------------|-----------------|--------------|----------|---------|
| 1 | 32.9100 | 34.31 | -14.89 | 19.42 | 40.00 | -20.58 | Peak | |
| 2 | 185.2000 | 34.64 | -12.46 | 22.18 | 43.50 | -21.32 | Peak | |
| 3 * | 291.9000 | 41.30 | -13.94 | 27.36 | 46.00 | -18.64 | Peak | |
| 4 | 421.8800 | 36.03 | -10.74 | 25.29 | 46.00 | -20.71 | Peak | |
| 5 | 565.4400 | 31.90 | -7.32 | 24.58 | 46.00 | -21.42 | Peak | |
| 6 | 674.0800 | 29.99 | -4.74 | 25.25 | 46.00 | -20.75 | Peak | |

APPENDIX D - RADIATED EMISSION (ABOVE 1000MHZ)

Test Mode : TX 2402MHz _CH00_1Mbps

Vertical

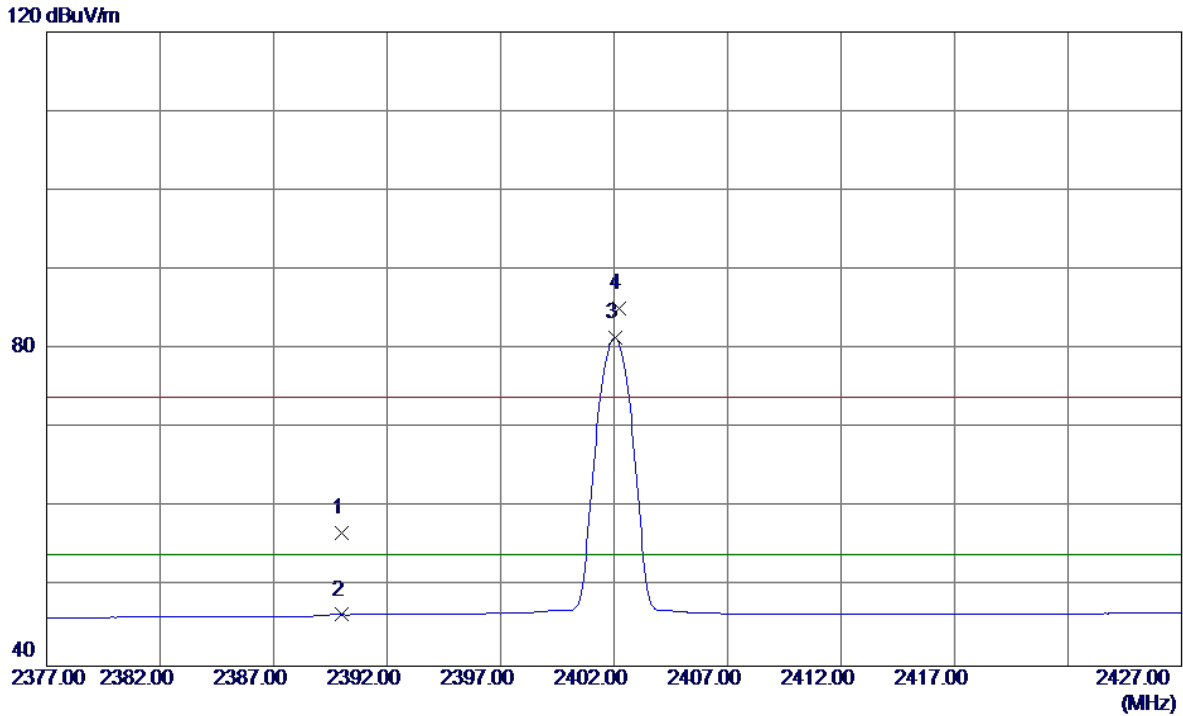

| No. | Freq. MHz | Reading Level dBuV/m | Correct Factor dB | Measure ment dBuV/m | Limit dBuV/m | Margin dB | Detector | Comment |
|-----|--------------|----------------------------|-------------------------|---------------------------|-----------------|--------------|----------|----------|
| 1 | 2390.0000 | 24.08 | 32.70 | 56.78 | 74.00 | -17.22 | Peak | |
| 2 | 2390.0000 | 13.78 | 32.70 | 46.48 | 54.00 | -7.52 | AVG | |
| 3 * | 2402.0500 | 48.63 | 32.75 | 81.38 | 54.00 | 27.38 | AVG | No Limit |
| 4 | 2402.2000 | 52.42 | 32.75 | 85.17 | 74.00 | 11.17 | Peak | No Limit |

Test Mode : TX 2402MHz _CH00_1Mbps

Vertical

80 dBuV/m

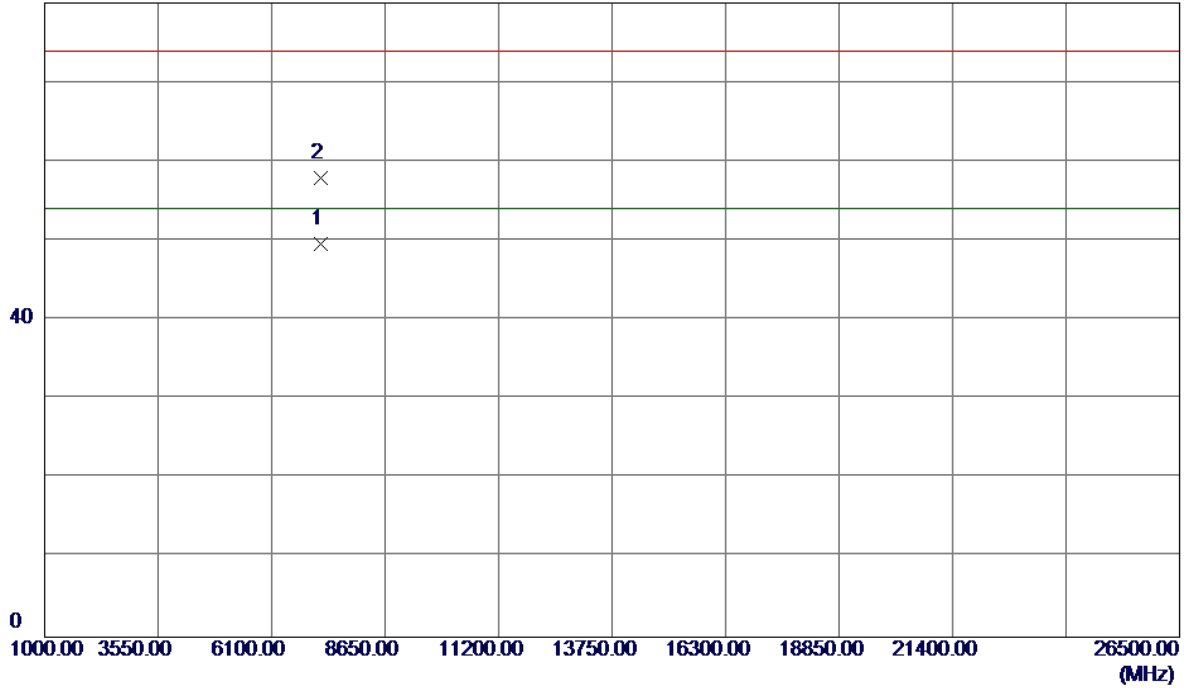

| No. | Freq. MHz | Reading Level dBuV/m | Correct Factor dB | Measure ment dBuV/m | Limit dBuV/m | Margin dB | Detector | Comment |
|-----|--------------|----------------------------|-------------------------|---------------------------|-----------------|--------------|----------|---------|
| 1 * | 7205.9220 | 36.46 | 13.13 | 49.59 | 54.00 | -4.41 | AVG | |
| 2 | 7206.4860 | 44.72 | 13.13 | 57.85 | 74.00 | -16.15 | Peak | |

Test Mode : TX 2402MHz _CH00_1Mbps

Horizontal

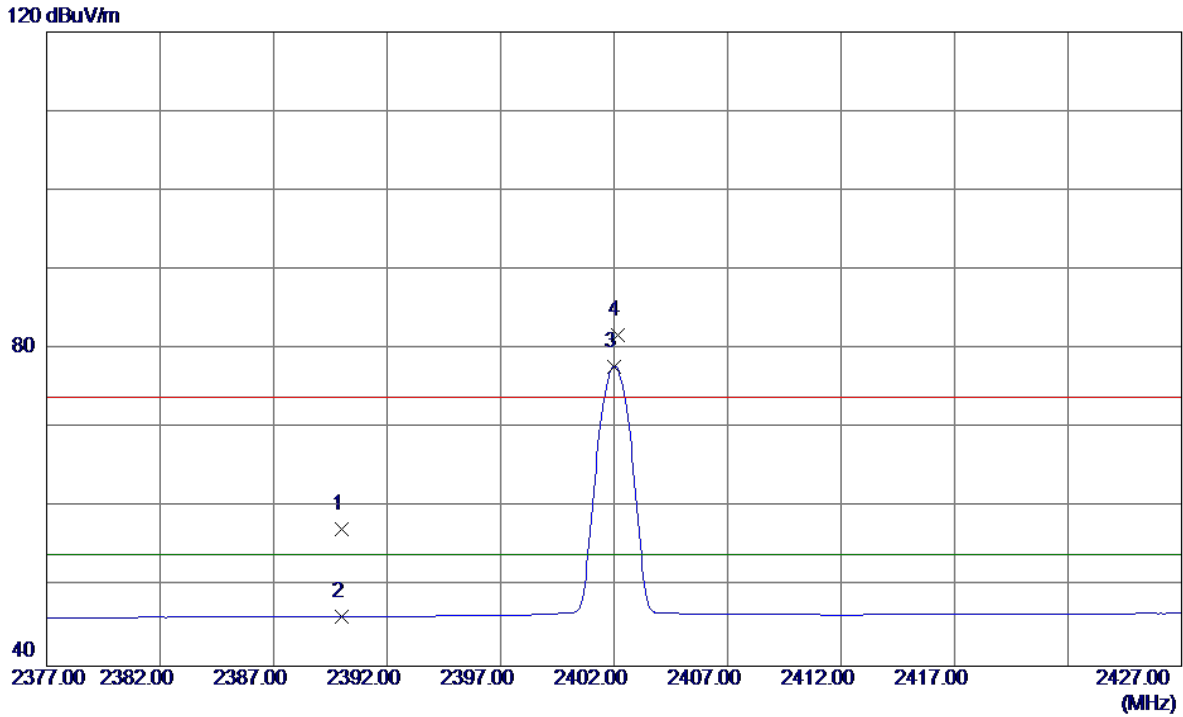

| No. | Freq. MHz | Reading Level dBuV/m | Correct Factor dB | Measure ment dBuV/m | Limit dBuV/m | Margin dB | Detector | Comment |
|-----|--------------|----------------------------|-------------------------|---------------------------|-----------------|--------------|----------|----------|
| 1 | 2390.0000 | 24.55 | 32.70 | 57.25 | 74.00 | -16.75 | Peak | |
| 2 | 2390.0000 | 13.57 | 32.70 | 46.27 | 54.00 | -7.73 | AVG | |
| 3 * | 2402.0000 | 45.06 | 32.75 | 77.81 | 54.00 | 23.81 | AVG | No Limit |
| 4 | 2402.1500 | 49.03 | 32.75 | 81.78 | 74.00 | 7.78 | Peak | No Limit |

Test Mode : TX 2402MHz _CH00_1Mbps

Horizontal

80 dBuV/m

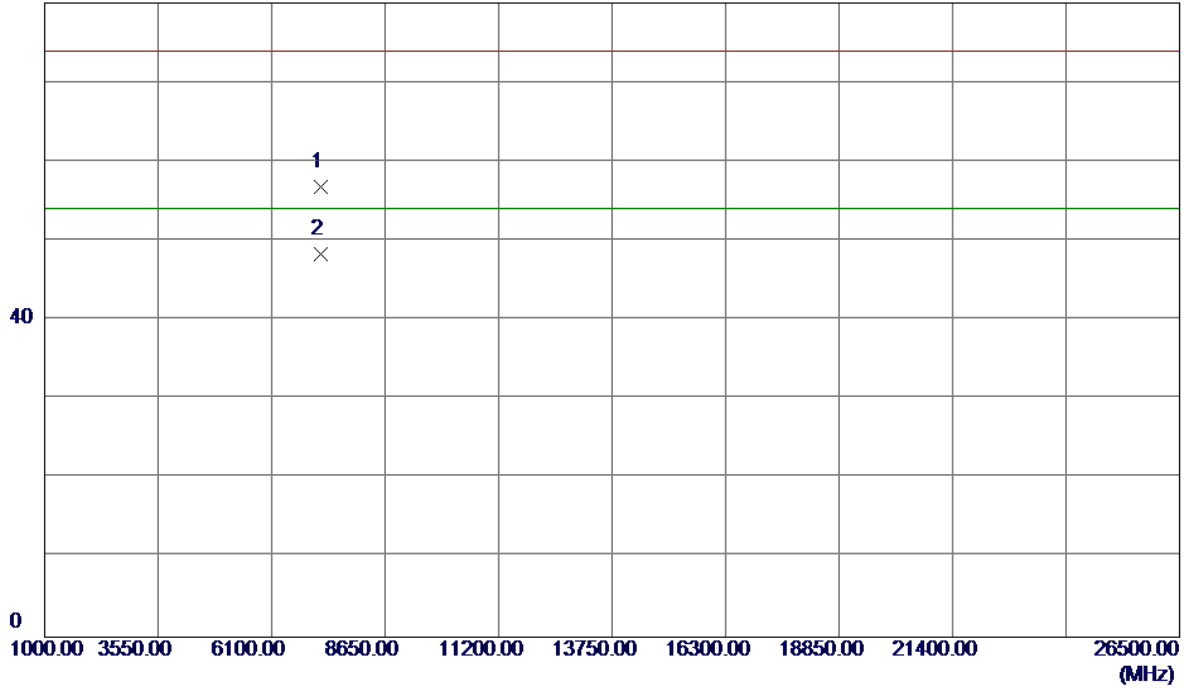

| No. | Freq. MHz | Reading Level dBuV/m | Correct Factor dB | Measure ment dBuV/m | Limit dBuV/m | Margin dB | Detector | Comment |
|-----|--------------|----------------------------|-------------------------|---------------------------|-----------------|--------------|----------|---------|
| 1 | 7205.5200 | 43.63 | 13.13 | 56.76 | 74.00 | -17.24 | Peak | |
| 2 * | 7206.0000 | 35.21 | 13.13 | 48.34 | 54.00 | -5.66 | AVG | |

Test Mode : TX 2441MHz _CH39_1Mbps

Vertical

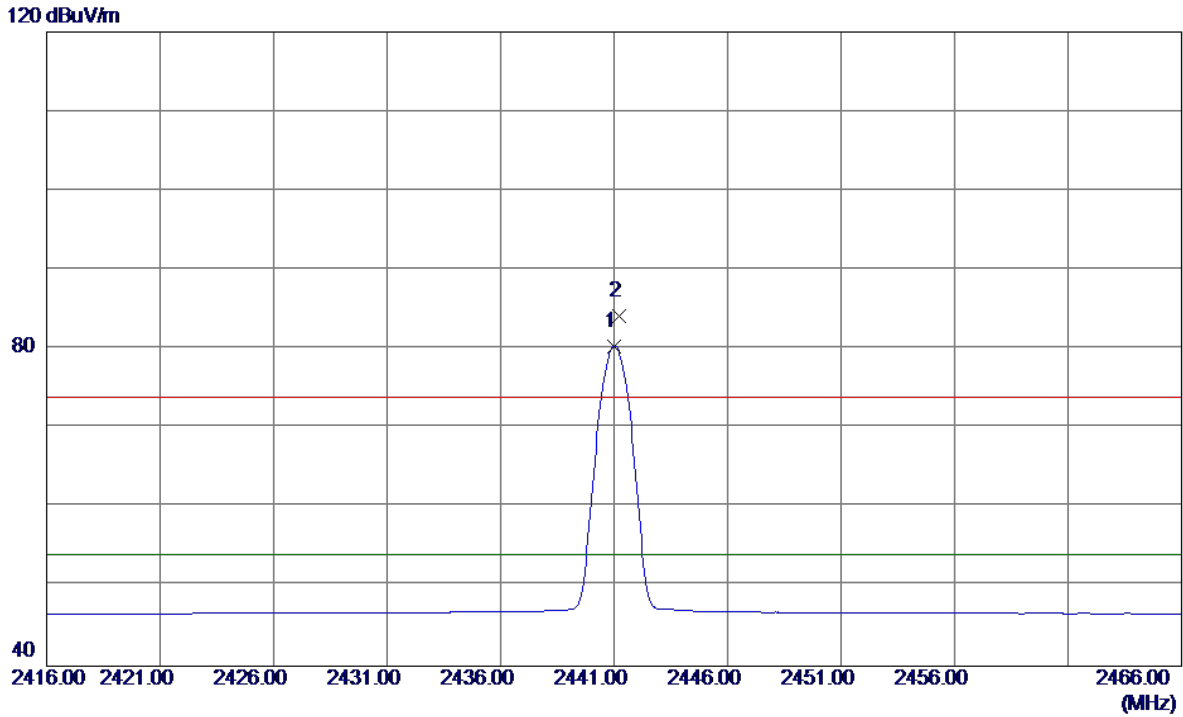

| No. | Freq. MHz | Reading Level dBuV/m | Correct Factor dB | Measure ment dBuV/m | Limit dBuV/m | Margin dB | Detector | Comment |
|-----|--------------|----------------------------|-------------------------|---------------------------|-----------------|--------------|----------|----------|
| 1 * | 2441.0000 | 47.44 | 32.89 | 80.33 | 54.00 | 26.33 | AVG | No Limit |
| 2 | 2441.2000 | 51.33 | 32.89 | 84.22 | 74.00 | 10.22 | Peak | No Limit |

Test Mode : TX 2441MHz _CH39_1Mbps

Vertical

80 dBuV/m

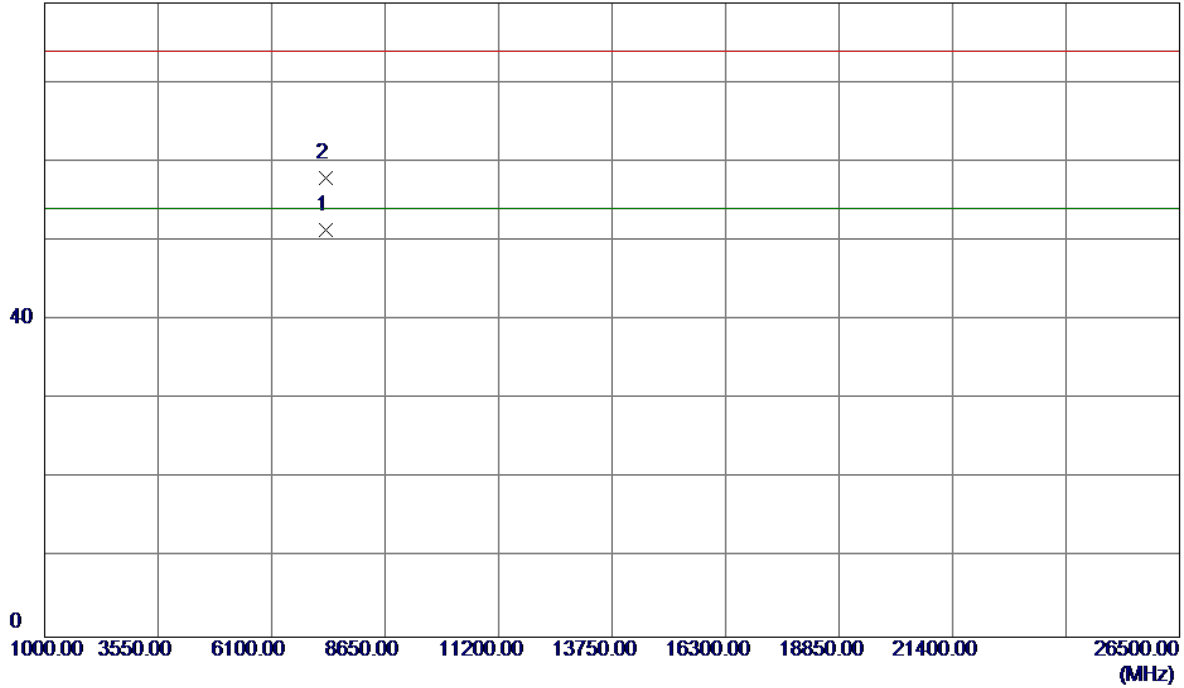

| No. | Freq. MHz | Reading Level dBuV/m | Correct Factor dB | Measure ment dBuV/m | Limit dBuV/m | Margin dB | Detector | Comment |
|-----|--------------|----------------------------|-------------------------|---------------------------|-----------------|--------------|----------|---------|
| 1 * | 7322.8060 | 38.21 | 13.22 | 51.43 | 54.00 | -2.57 | AVG | |
| 2 | 7323.4180 | 44.64 | 13.22 | 57.86 | 74.00 | -16.14 | Peak | |

Test Mode : TX 2441MHz _CH39_1Mbps

Horizontal

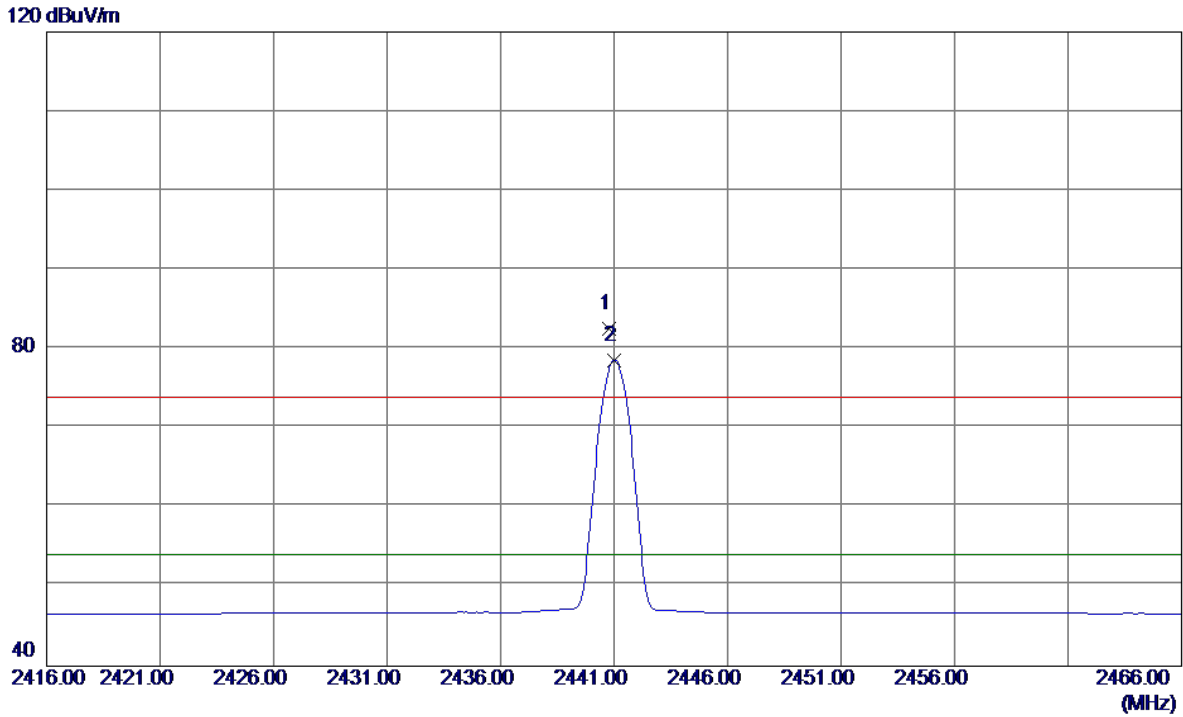

| No. | Freq. MHz | Reading Level dBuV/m | Correct Factor dB | Measure ment dBuV/m | Limit dBuV/m | Margin dB | Detector | Comment |
|-----|--------------|----------------------------|-------------------------|---------------------------|-----------------|--------------|----------|----------|
| 1 | 2440.8000 | 49.70 | 32.89 | 82.59 | 74.00 | 8.59 | Peak | No Limit |
| 2 * | 2441.0000 | 45.73 | 32.89 | 78.62 | 54.00 | 24.62 | AVG | No Limit |

Test Mode : TX 2441MHz _CH39_1Mbps

Horizontal

80 dBuV/m

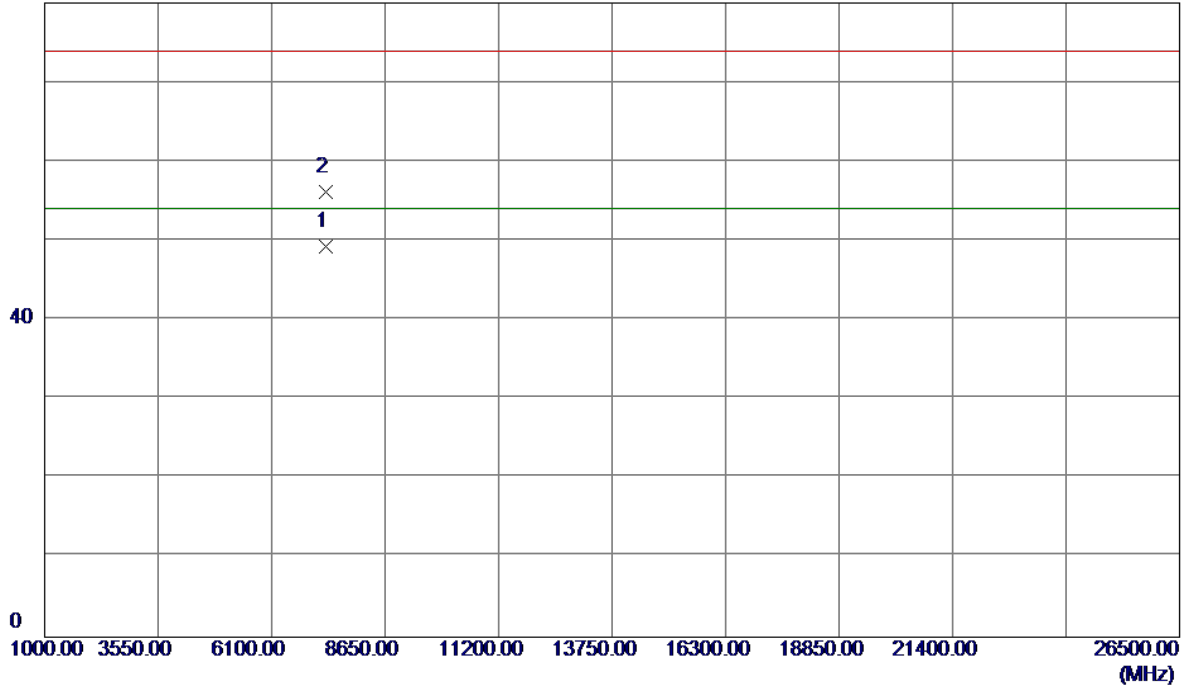

| No. | Freq. MHz | Reading Level dBuV/m | Correct Factor dB | Measure ment dBuV/m | Limit dBuV/m | Margin dB | Detector | Comment |
|-----|--------------|----------------------------|-------------------------|---------------------------|-----------------|--------------|----------|---------|
| 1 * | 7323.0280 | 36.06 | 13.22 | 49.28 | 54.00 | -4.72 | AVG | |
| 2 | 7323.5060 | 42.92 | 13.22 | 56.14 | 74.00 | -17.86 | Peak | |

Test Mode : TX 2480MHz _CH78_1Mbps

Vertical

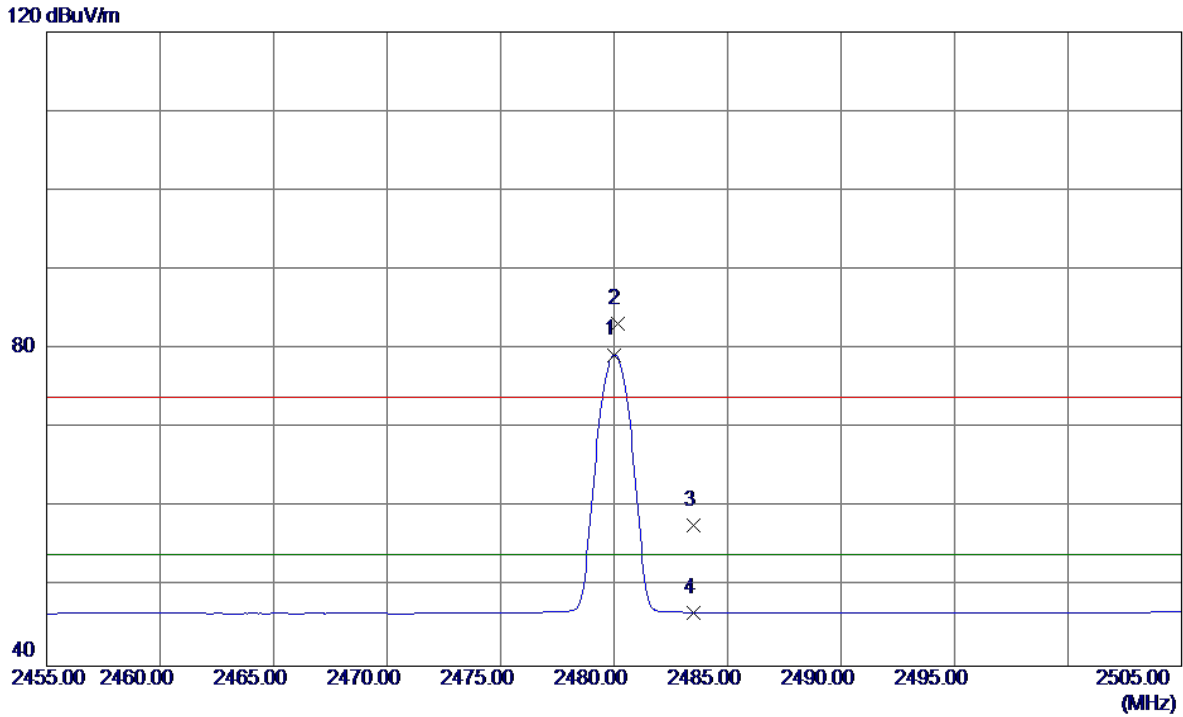

| No. | Freq. MHz | Reading Level dBuV/m | Correct Factor dB | Measure ment dBuV/m | Limit dBuV/m | Margin dB | Detector | Comment |
|-----|--------------|----------------------------|-------------------------|---------------------------|-----------------|--------------|----------|----------|
| 1 * | 2480.0000 | 46.24 | 33.04 | 79.28 | 54.00 | 25.28 | AVG | No Limit |
| 2 | 2480.1500 | 50.09 | 33.04 | 83.13 | 74.00 | 9.13 | Peak | No Limit |
| 3 | 2483.5000 | 24.69 | 33.05 | 57.74 | 74.00 | -16.26 | Peak | |
| 4 | 2483.5000 | 13.69 | 33.05 | 46.74 | 54.00 | -7.26 | AVG | |

Test Mode : TX 2480MHz _CH78_1Mbps

Vertical

80 dBuV/m

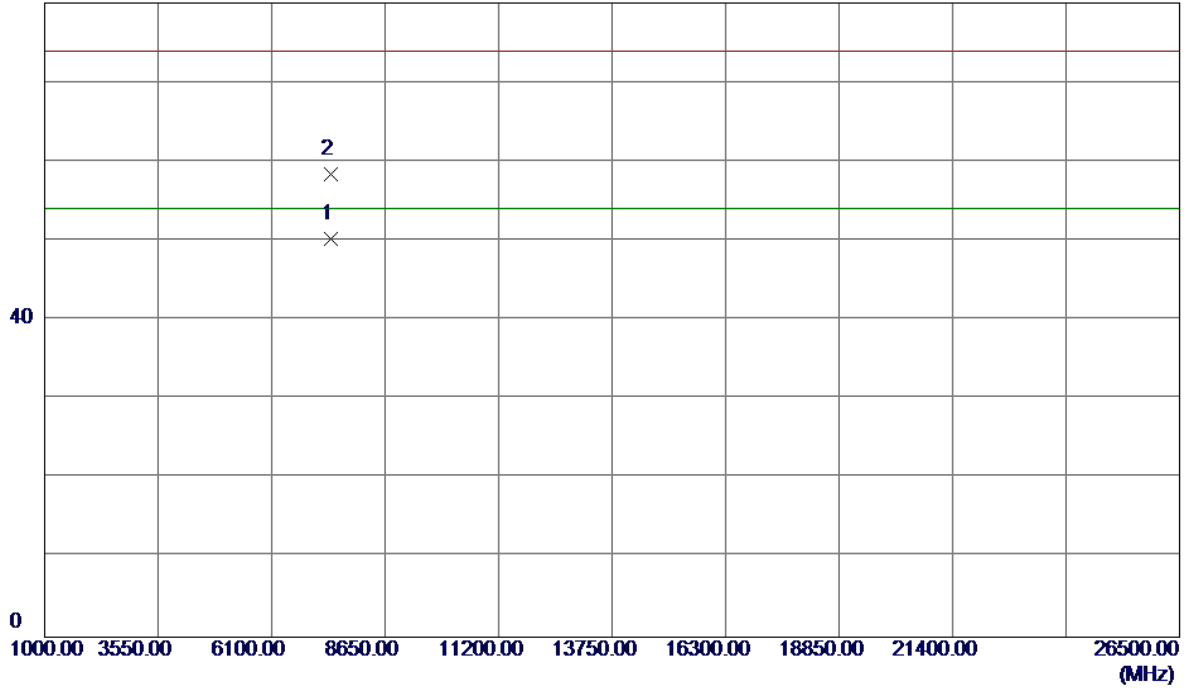

| No. | Freq. MHz | Reading Level dBuV/m | Correct Factor dB | Measure ment dBuV/m | Limit dBuV/m | Margin dB | Detector | Comment |
|-----|--------------|----------------------------|-------------------------|---------------------------|-----------------|--------------|----------|---------|
| 1 * | 7439.9840 | 36.93 | 13.31 | 50.24 | 54.00 | -3.76 | AVG | |
| 2 | 7440.3960 | 45.07 | 13.31 | 58.38 | 74.00 | -15.62 | Peak | |

Test Mode : TX 2480MHz _CH78_1Mbps

Horizontal

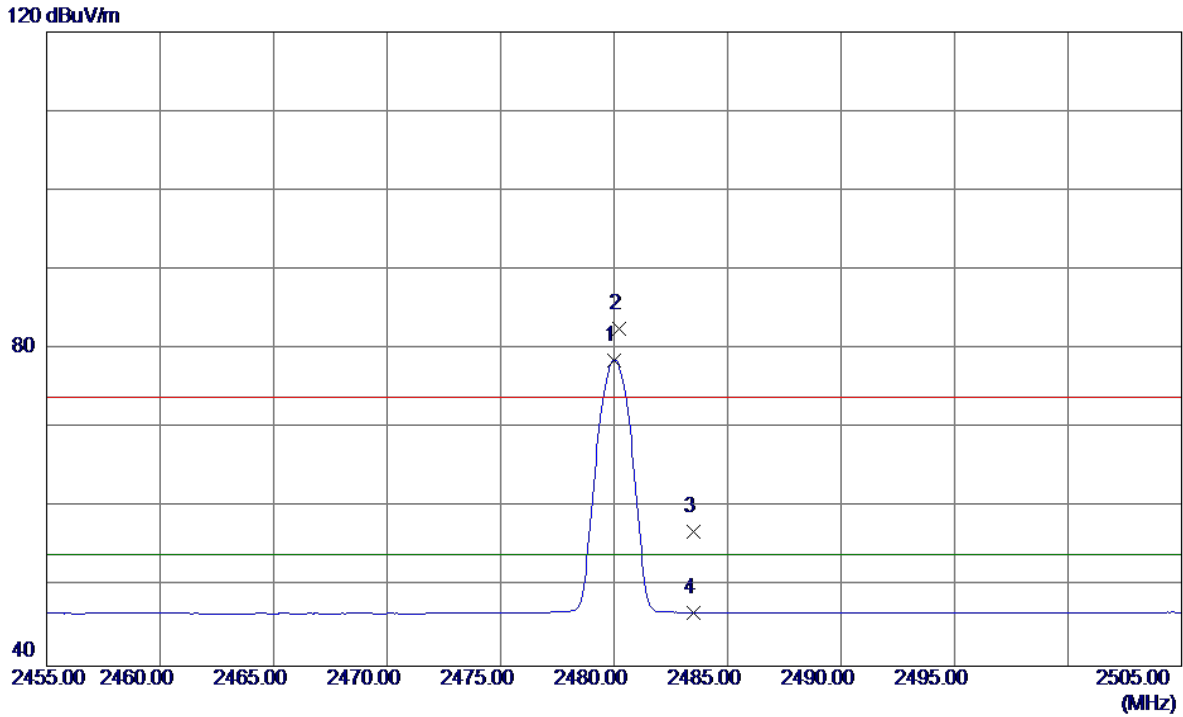

| No. | Freq. MHz | Reading Level dBuV/m | Correct Factor dB | Measure ment dBuV/m | Limit dBuV/m | Margin dB | Detector | Comment |
|-----|--------------|----------------------------|-------------------------|---------------------------|-----------------|--------------|----------|----------|
| 1 * | 2480.0000 | 45.58 | 33.04 | 78.62 | 54.00 | 24.62 | AVG | No Limit |
| 2 | 2480.2000 | 49.55 | 33.04 | 82.59 | 74.00 | 8.59 | Peak | No Limit |
| 3 | 2483.5000 | 23.96 | 33.05 | 57.01 | 74.00 | -16.99 | Peak | |
| 4 | 2483.5000 | 13.67 | 33.05 | 46.72 | 54.00 | -7.28 | AVG | |

Test Mode : TX 2480MHz _CH78_1Mbps

Horizontal

80 dBuV/m

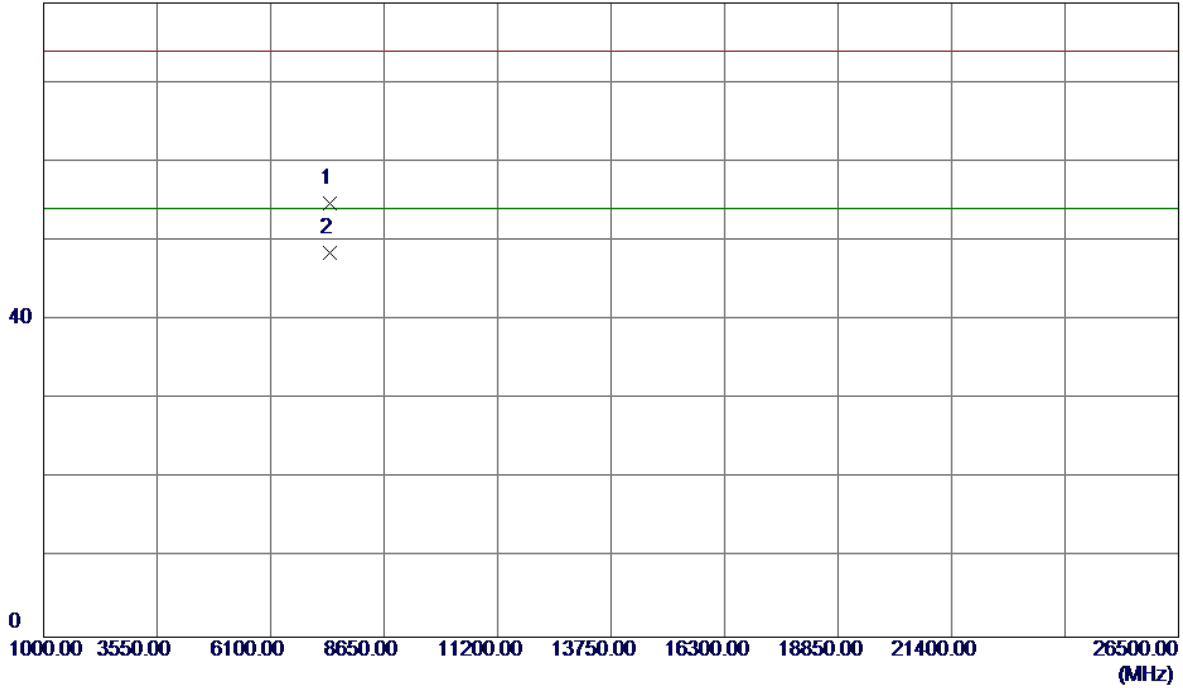

| No. | Freq. MHz | Reading Level dBuV/m | Correct Factor dB | Measure ment dBuV/m | Limit dBuV/m | Margin dB | Detector | Comment |
|-----|--------------|----------------------------|-------------------------|---------------------------|-----------------|--------------|----------|---------|
| 1 | 7439.3460 | 41.39 | 13.31 | 54.70 | 74.00 | -19.30 | Peak | |
| 2 * | 7440.0080 | 35.10 | 13.31 | 48.41 | 54.00 | -5.59 | AVG | |

Test Mode : TX 2402MHz _CH00_3Mbps

Vertical

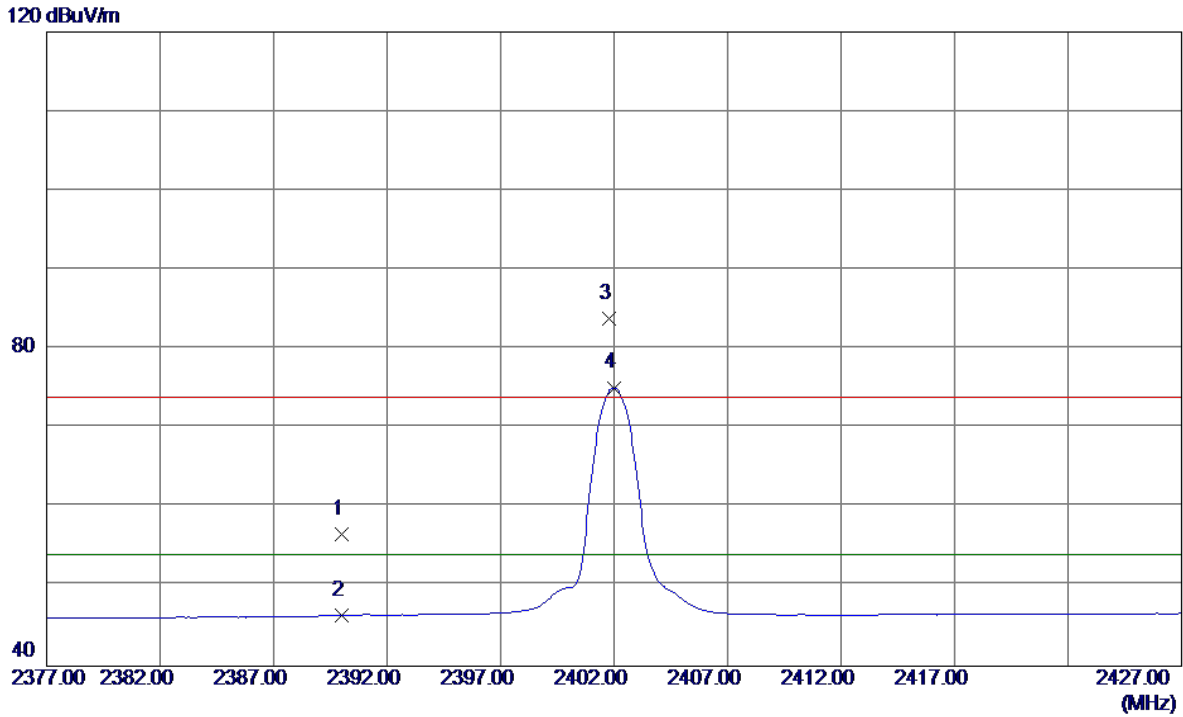

| No. | Freq. MHz | Reading Level dBuV/m | Correct Factor dB | Measure ment dBuV/m | Limit dBuV/m | Margin dB | Detector | Comment |
|-----|--------------|----------------------------|-------------------------|---------------------------|-----------------|--------------|----------|----------|
| 1 | 2390.0000 | 23.97 | 32.70 | 56.67 | 74.00 | -17.33 | Peak | |
| 2 | 2390.0000 | 13.74 | 32.70 | 46.44 | 54.00 | -7.56 | AVG | |
| 3 | 2401.8000 | 51.16 | 32.75 | 83.91 | 74.00 | 9.91 | Peak | No Limit |
| 4 * | 2402.0000 | 42.37 | 32.75 | 75.12 | 54.00 | 21.12 | AVG | No Limit |

Test Mode : TX 2402MHz _CH00_3Mbps

Vertical

80 dBuV/m

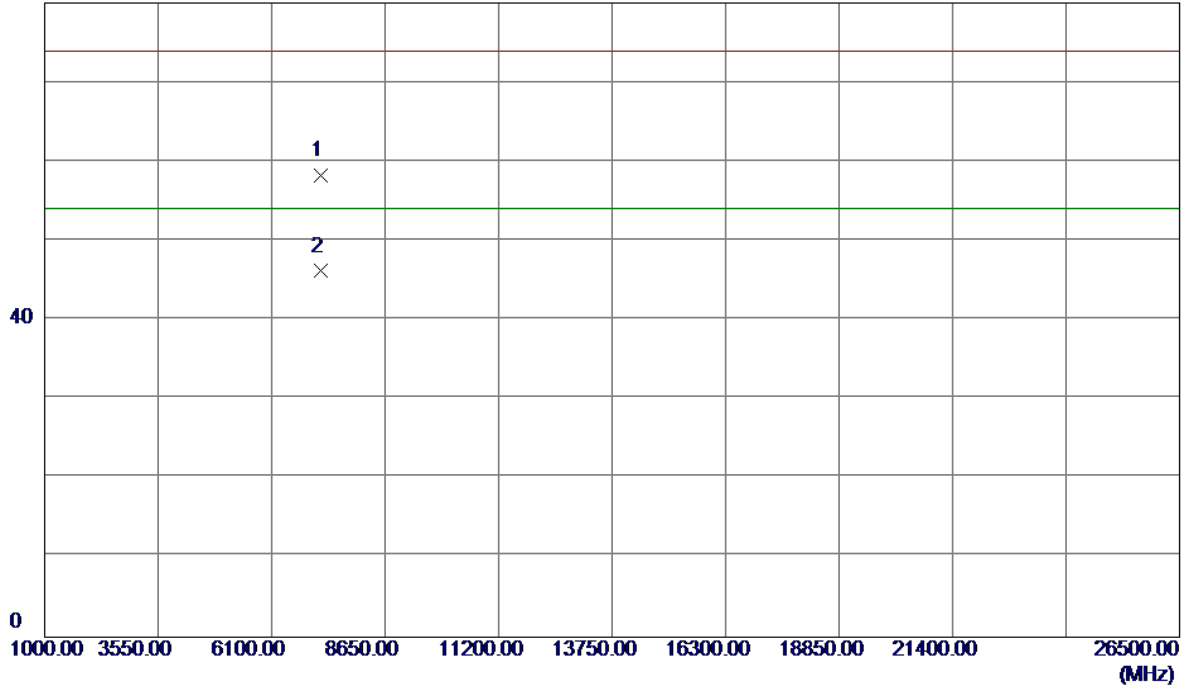

| No. | Freq. MHz | Reading Level dBuV/m | Correct Factor dB | Measure ment dBuV/m | Limit dBuV/m | Margin dB | Detector | Comment |
|-----|--------------|----------------------------|-------------------------|---------------------------|-----------------|--------------|----------|---------|
| 1 | 7205.4020 | 45.15 | 13.13 | 58.28 | 74.00 | -15.72 | Peak | |
| 2 * | 7205.7740 | 33.03 | 13.13 | 46.16 | 54.00 | -7.84 | AVG | |

Test Mode : TX 2402MHz _CH00_3Mbps

Horizontal

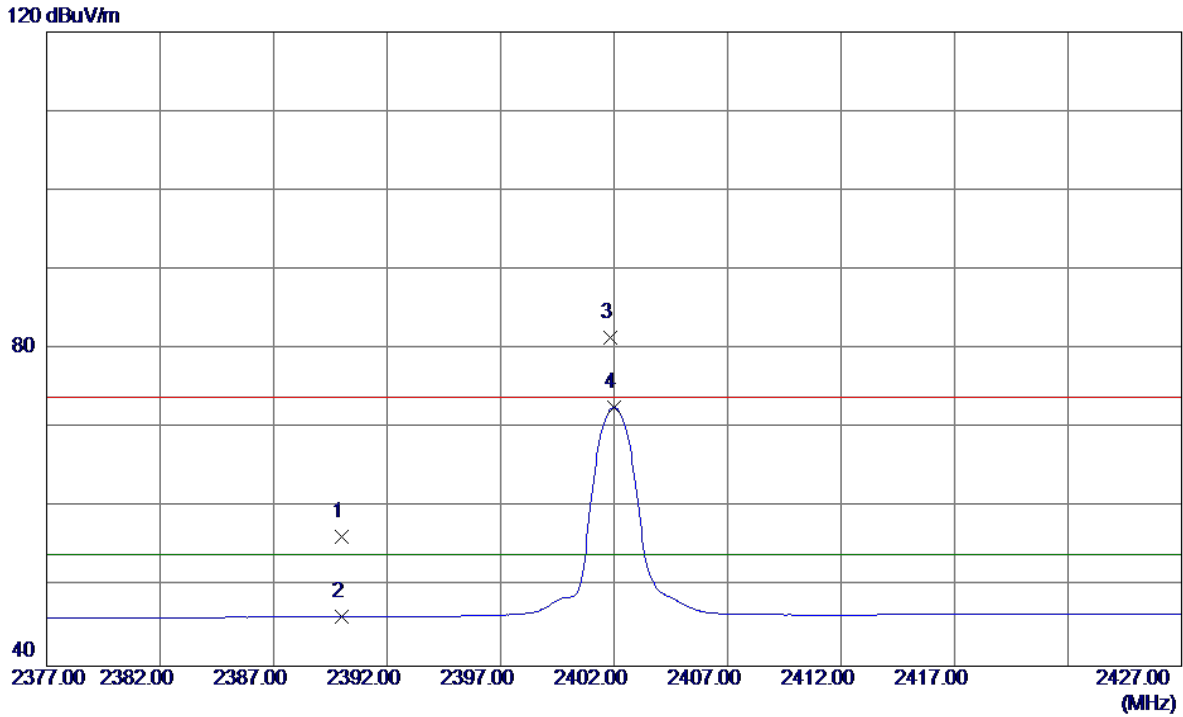

| No. | Freq. MHz | Reading Level dBuV/m | Correct Factor dB | Measure ment dBuV/m | Limit dBuV/m | Margin dB | Detector | Comment |
|-----|--------------|----------------------------|-------------------------|---------------------------|-----------------|--------------|----------|----------|
| 1 | 2390.0000 | 23.66 | 32.70 | 56.36 | 74.00 | -17.64 | Peak | |
| 2 | 2390.0000 | 13.53 | 32.70 | 46.23 | 54.00 | -7.77 | AVG | |
| 3 | 2401.8500 | 48.74 | 32.75 | 81.49 | 74.00 | 7.49 | Peak | No Limit |
| 4 * | 2402.0000 | 39.84 | 32.75 | 72.59 | 54.00 | 18.59 | AVG | No Limit |

Test Mode : TX 2402MHz _CH00_3Mbps

Horizontal

80 dBuV/m

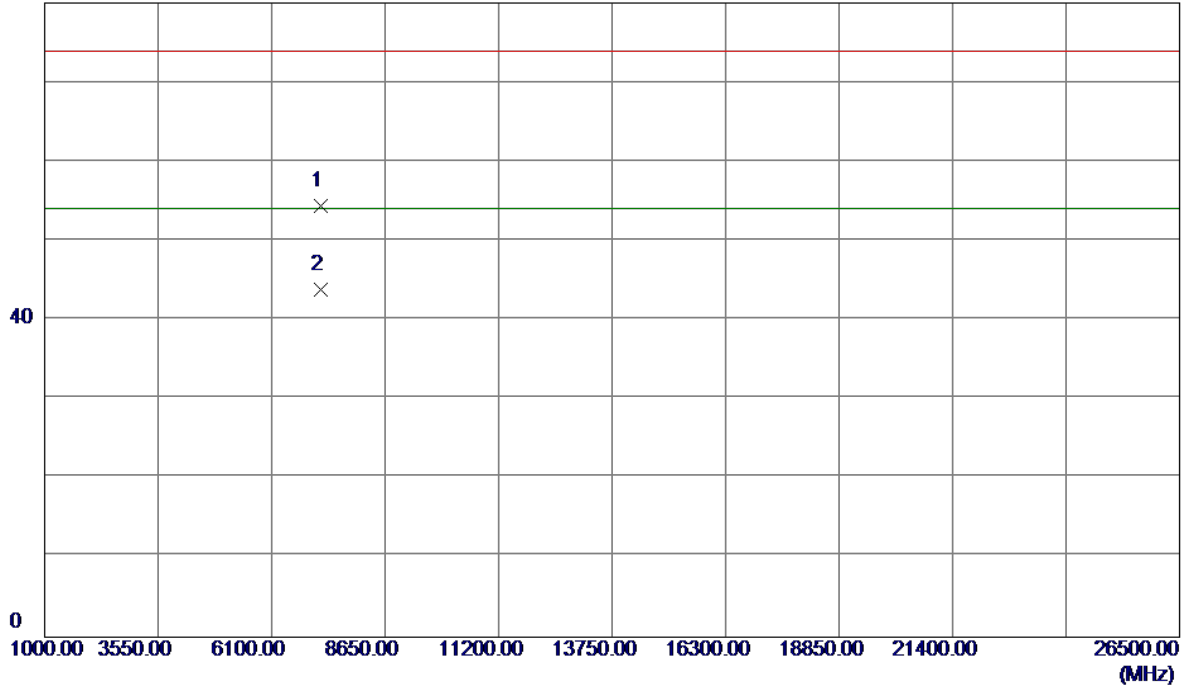

| No. | Freq. MHz | Reading Level dBuV/m | Correct Factor dB | Measure ment dBuV/m | Limit dBuV/m | Margin dB | Detector | Comment |
|-----|--------------|----------------------------|-------------------------|---------------------------|-----------------|--------------|----------|---------|
| 1 | 7205.2660 | 41.21 | 13.13 | 54.34 | 74.00 | -19.66 | Peak | |
| 2 * | 7205.5800 | 30.67 | 13.13 | 43.80 | 54.00 | -10.20 | AVG | |

Test Mode : TX 2441MHz _CH39_3Mbps

Vertical

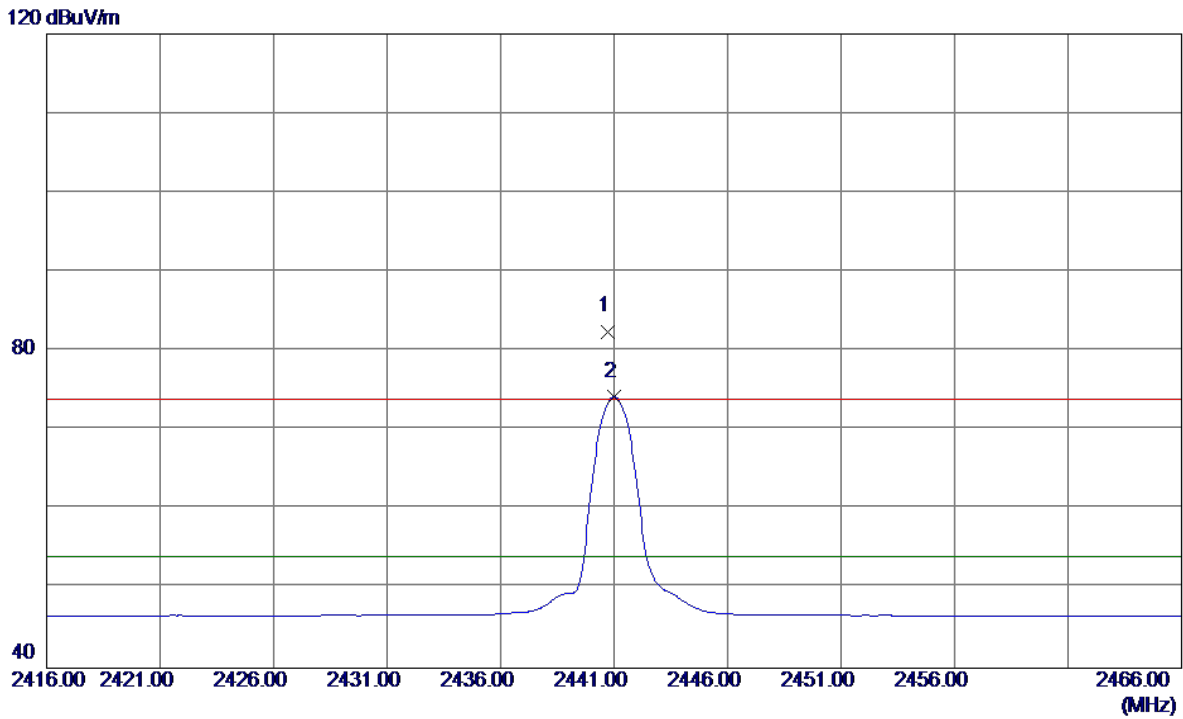

| No. | Freq. MHz | Reading Level dBuV/m | Correct Factor dB | Measure ment dBuV/m | Limit dBuV/m | Margin dB | Detector | Comment |
|-----|--------------|----------------------------|-------------------------|---------------------------|-----------------|--------------|----------|----------|
| 1 | 2440.7000 | 49.59 | 32.89 | 82.48 | 74.00 | 8.48 | Peak | No Limit |
| 2 * | 2441.0000 | 41.31 | 32.89 | 74.20 | 54.00 | 20.20 | AVG | No Limit |

Test Mode : TX 2441MHz _CH39_3Mbps

Vertical

80 dBuV/m

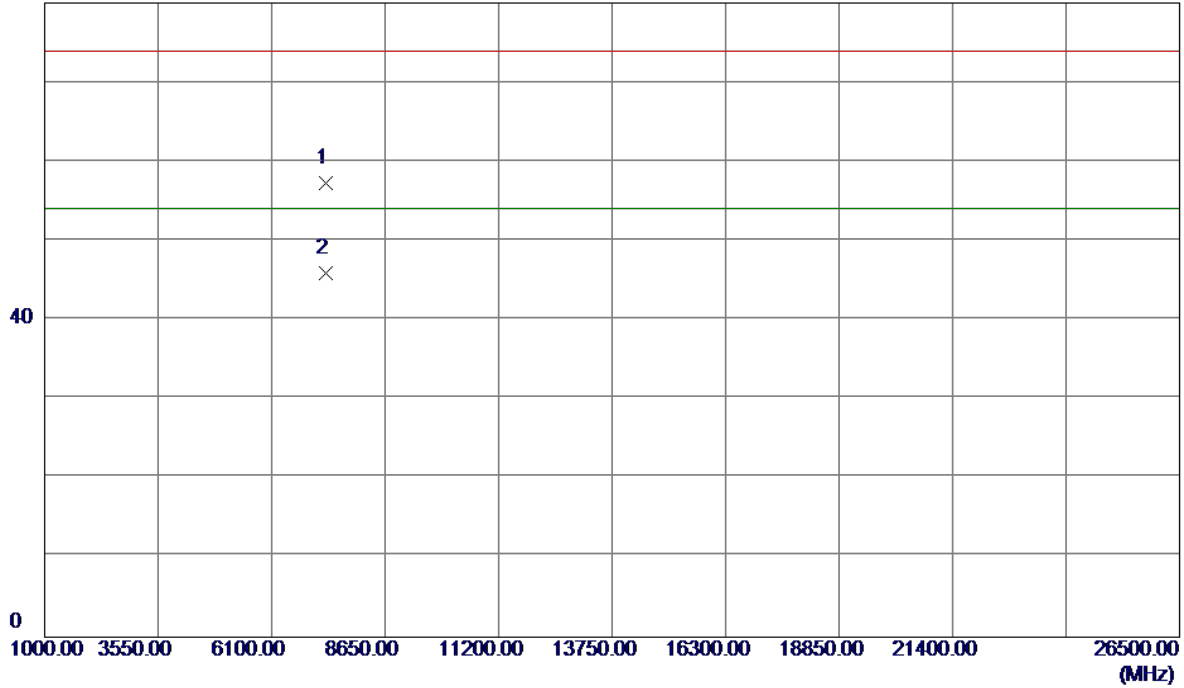

| No. | Freq. MHz | Reading Level dBuV/m | Correct Factor dB | Measure ment dBuV/m | Limit dBuV/m | Margin dB | Detector | Comment |
|-----|--------------|----------------------------|-------------------------|---------------------------|-----------------|--------------|----------|---------|
| 1 | 7322.5040 | 44.06 | 13.22 | 57.28 | 74.00 | -16.72 | Peak | |
| 2 * | 7322.5160 | 32.77 | 13.22 | 45.99 | 54.00 | -8.01 | AVG | |

Test Mode : TX 2441MHz _CH39_3Mbps

Horizontal

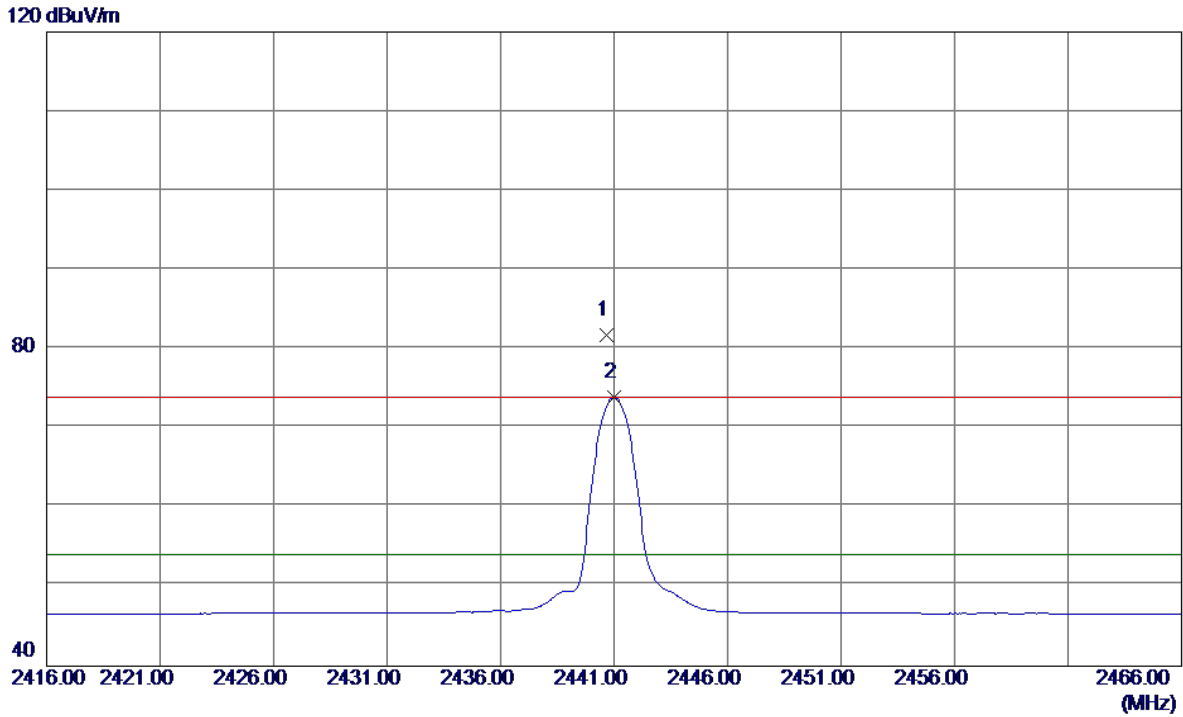

| No. | Freq. MHz | Reading Level dBuV/m | Correct Factor dB | Measure ment dBuV/m | Limit dBuV/m | Margin dB | Detector | Comment |
|-----|--------------|----------------------------|-------------------------|---------------------------|-----------------|--------------|----------|----------|
| 1 | 2440.6500 | 48.91 | 32.89 | 81.80 | 74.00 | 7.80 | Peak | No Limit |
| 2 * | 2441.0000 | 41.00 | 32.89 | 73.89 | 54.00 | 19.89 | AVG | No Limit |

Test Mode : TX 2441MHz _CH39_3Mbps

Horizontal

80 dBuV/m

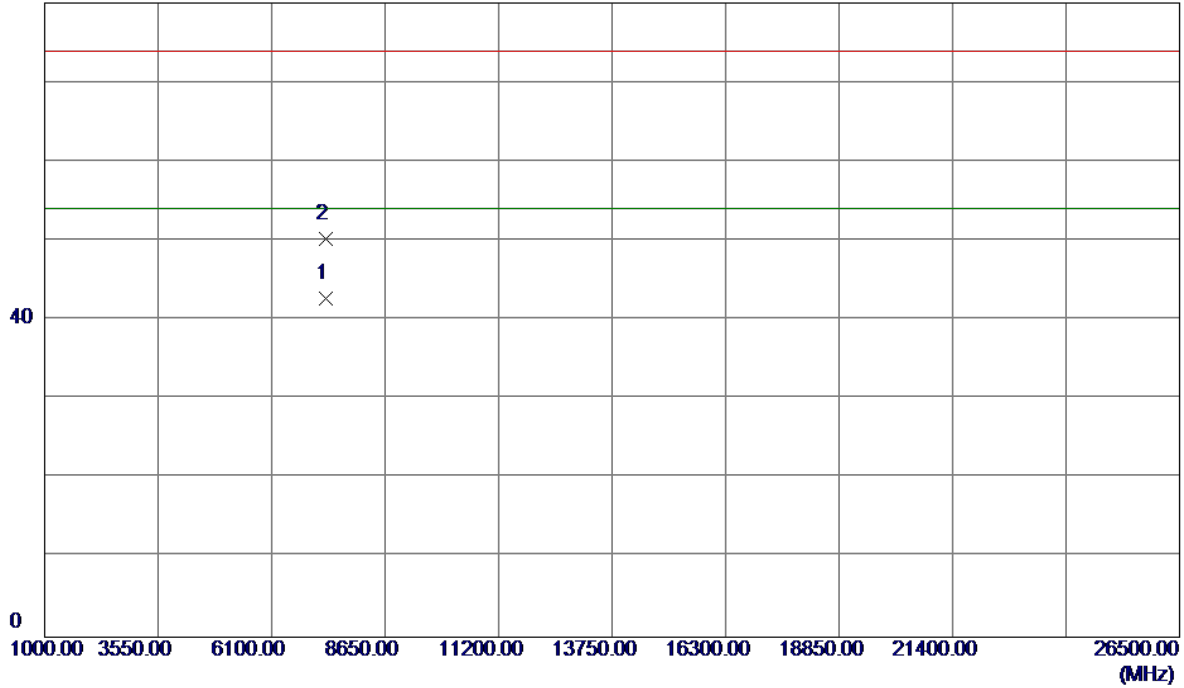

| No. | Freq. MHz | Reading Level dBuV/m | Correct Factor dB | Measure ment dBuV/m | Limit dBuV/m | Margin dB | Detector | Comment |
|-----|--------------|----------------------------|-------------------------|---------------------------|-----------------|--------------|----------|---------|
| 1 * | 7322.7860 | 29.54 | 13.22 | 42.76 | 54.00 | -11.24 | AVG | |
| 2 | 7322.8140 | 37.01 | 13.22 | 50.23 | 74.00 | -23.77 | Peak | |

Test Mode : TX 2480MHz _CH78_3Mbps

Vertical

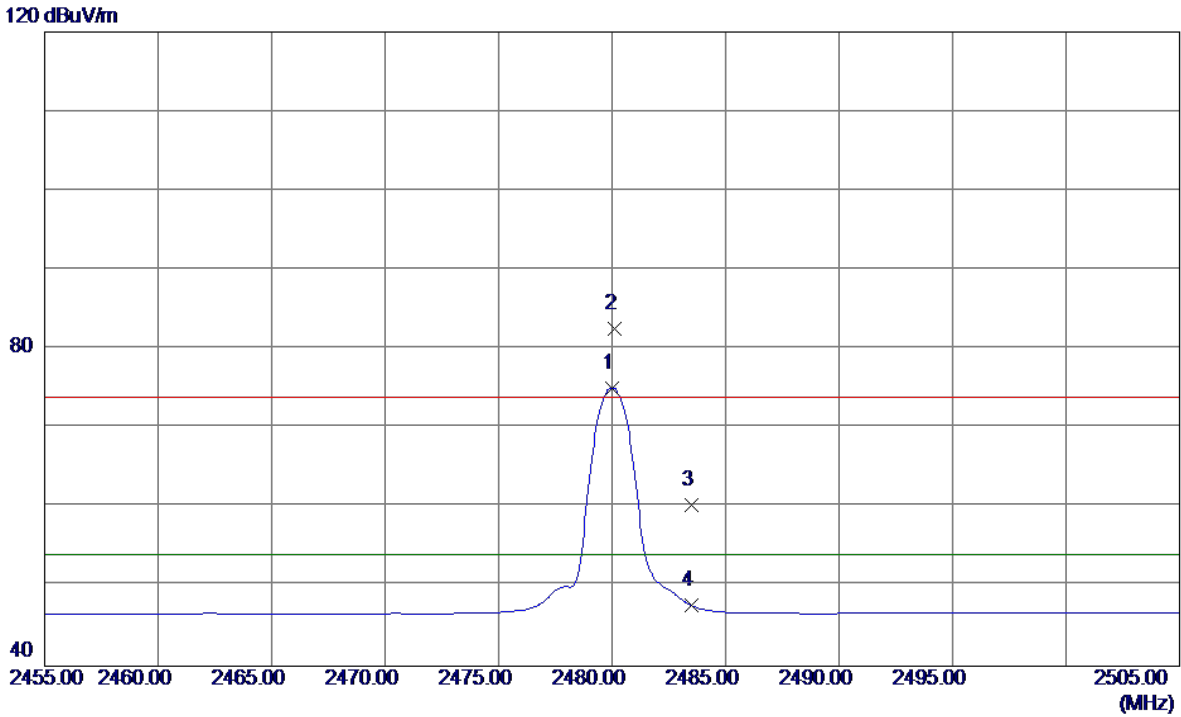

| No. | Freq. MHz | Reading Level dBuV/m | Correct Factor dB | Measure ment dBuV/m | Limit dBuV/m | Margin dB | Detector | Comment |
|-----|--------------|----------------------------|-------------------------|---------------------------|-----------------|--------------|----------|----------|
| 1 * | 2480.0000 | 42.06 | 33.04 | 75.10 | 54.00 | 21.10 | AVG | No Limit |
| 2 | 2480.1000 | 49.46 | 33.04 | 82.50 | 74.00 | 8.50 | Peak | No Limit |
| 3 | 2483.5000 | 27.20 | 33.05 | 60.25 | 74.00 | -13.75 | Peak | |
| 4 | 2483.5000 | 14.59 | 33.05 | 47.64 | 54.00 | -6.36 | AVG | |

Test Mode : TX 2480MHz _CH78_3Mbps

Vertical

80 dBuV/m

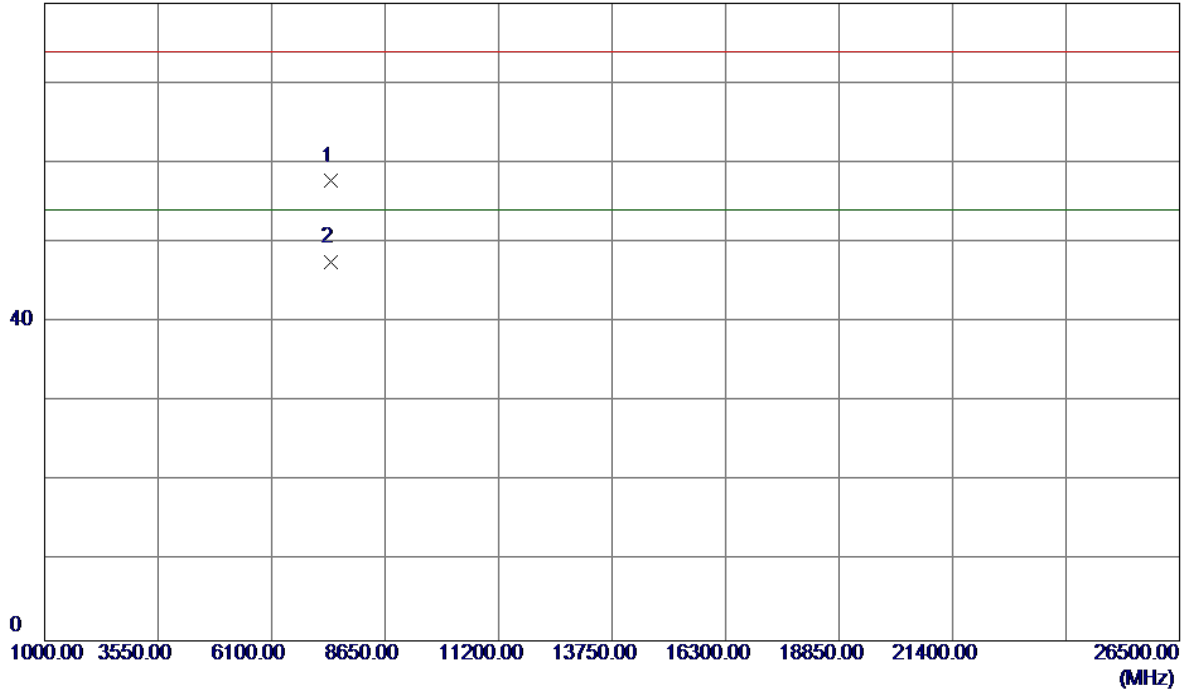

| No. | Freq. MHz | Reading Level dBuV/m | Correct Factor dB | Measure ment dBuV/m | Limit dBuV/m | Margin dB | Detector | Comment |
|-----|--------------|----------------------------|-------------------------|---------------------------|-----------------|--------------|----------|---------|
| 1 | 7439.3740 | 44.37 | 13.31 | 57.68 | 74.00 | -16.32 | Peak | |
| 2 * | 7439.8620 | 34.21 | 13.31 | 47.52 | 54.00 | -6.48 | AVG | |

Test Mode : TX 2480MHz _CH78_3Mbps

Horizontal

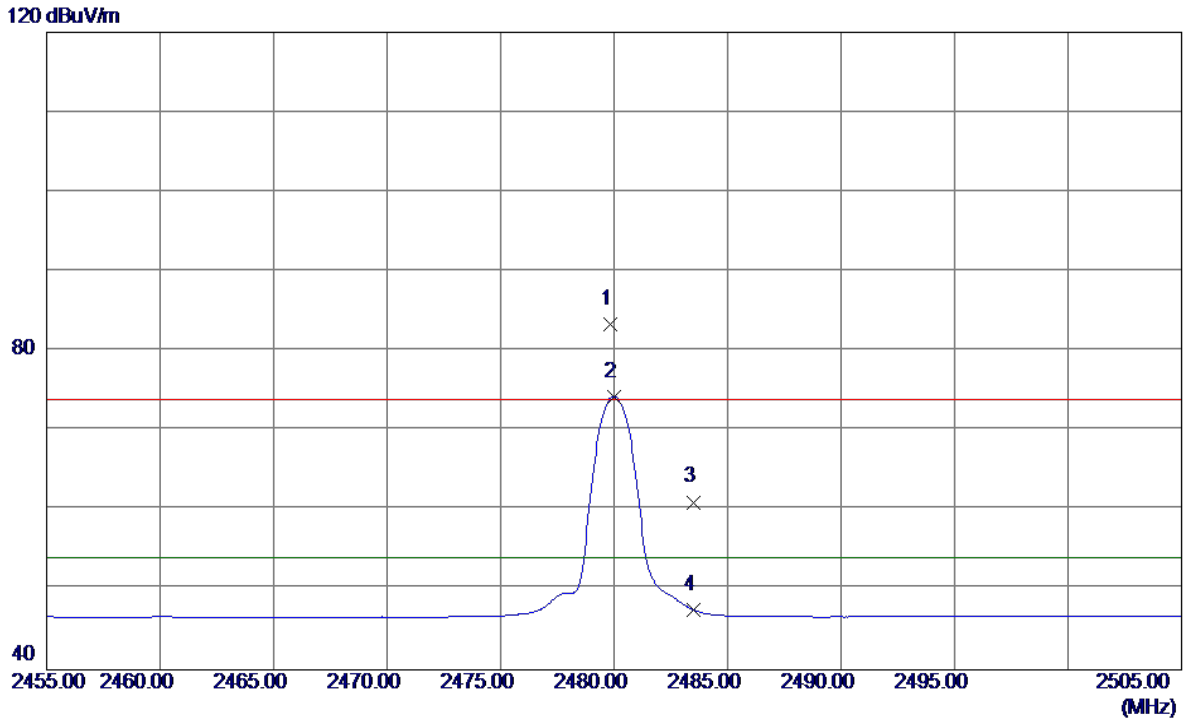

| No. | Freq. MHz | Reading Level dBuV/m | Correct Factor dB | Measure ment dBuV/m | Limit dBuV/m | Margin dB | Detector | Comment |
|-----|--------------|----------------------------|-------------------------|---------------------------|-----------------|--------------|----------|----------|
| 1 | 2479.8500 | 50.29 | 33.04 | 83.33 | 74.00 | 9.33 | Peak | No Limit |
| 2 * | 2480.0000 | 41.26 | 33.04 | 74.30 | 54.00 | 20.30 | AVG | No Limit |
| 3 | 2483.5000 | 27.99 | 33.05 | 61.04 | 74.00 | -12.96 | Peak | |
| 4 | 2483.5000 | 14.46 | 33.05 | 47.51 | 54.00 | -6.49 | AVG | |

Test Mode : TX 2480MHz _CH78_3Mbps

Horizontal

80 dBuV/m

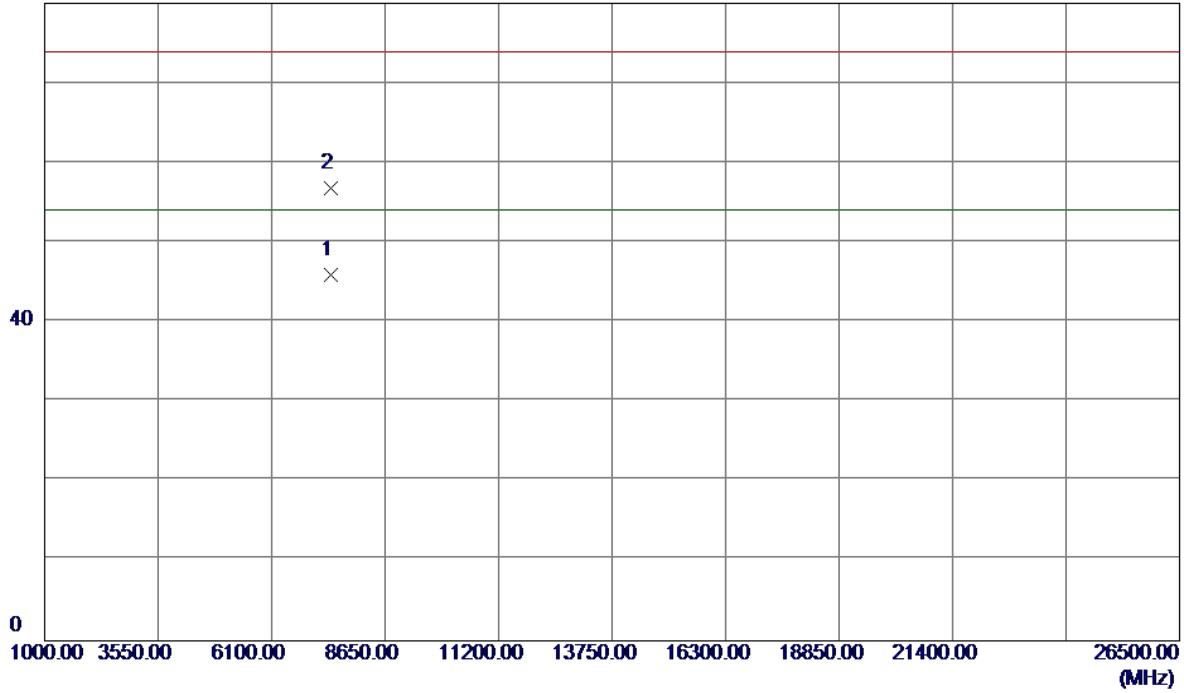

| No. | Freq. MHz | Reading Level dBuV/m | Correct Factor dB | Measure ment dBuV/m | Limit dBuV/m | Margin dB | Detector | Comment |
|-----|--------------|----------------------------|-------------------------|---------------------------|-----------------|--------------|----------|---------|
| 1 * | 7439.7180 | 32.67 | 13.31 | 45.98 | 54.00 | -8.02 | AVG | |
| 2 | 7439.7400 | 43.50 | 13.31 | 56.81 | 74.00 | -17.19 | Peak | |

APPENDIX E - NUMBER OF HOPPING CHANNEL

Test Mode

Hopping Mode_1Mbps

Number of Hopping Channel

79

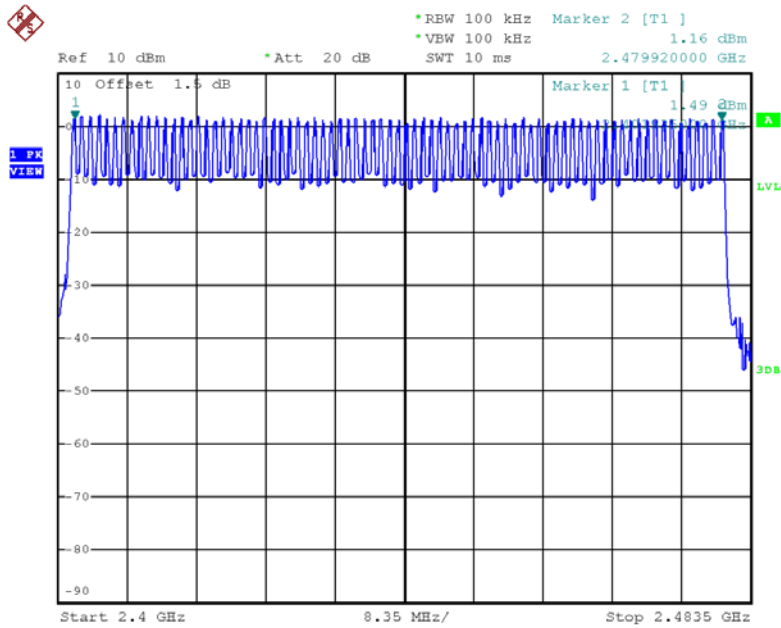

Date: 8.NOV.2017 11:05:35

Test Mode

Hopping Mode_3Mbps

Number of Hopping Channel

79

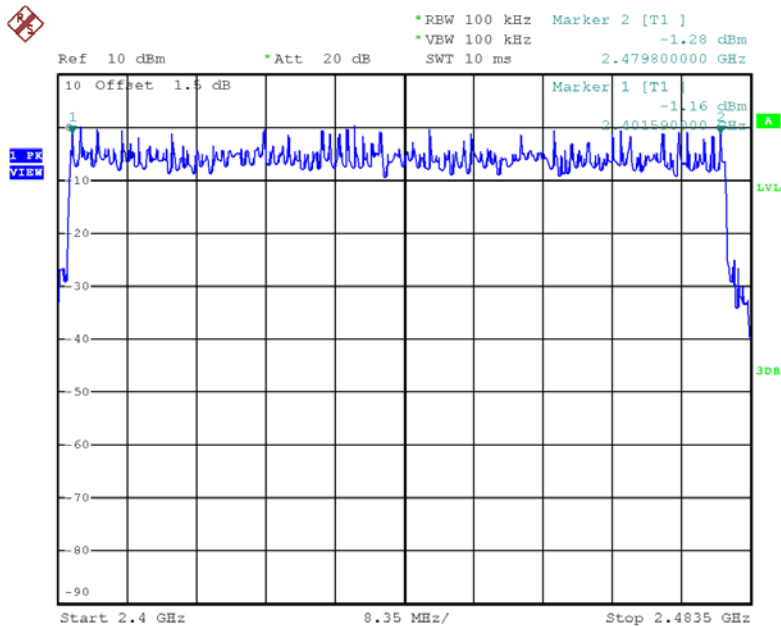

Date: 8.NOV.2017 11:21:21

APPENDIX F - AVERAGE TIME OF OCCUPANCY

| | |
|-------------|---------------|
| Test Mode : | TX Mode_1Mbps |
|-------------|---------------|

| Data Packet | Frequency (MHz) | Pulse Duration (ms) | Dwell Time (s) | Limits (s) | Test Result |
|-------------|-----------------|---------------------|----------------|------------|-------------|
| DH5 | 2402 | 2.7600 | 0.2944 | 0.4000 | Pass |
| DH3 | 2402 | 1.7600 | 0.2816 | 0.4000 | Pass |
| DH1 | 2402 | 0.4150 | 0.1328 | 0.4000 | Pass |
| DH5 | 2441 | 2.8000 | 0.2987 | 0.4000 | Pass |
| DH3 | 2441 | 1.6000 | 0.2560 | 0.4000 | Pass |
| DH1 | 2441 | 0.4000 | 0.1280 | 0.4000 | Pass |
| DH5 | 2480 | 2.7600 | 0.2944 | 0.4000 | Pass |
| DH3 | 2480 | 1.6200 | 0.2592 | 0.4000 | Pass |
| DH1 | 2480 | 0.4200 | 0.1344 | 0.4000 | Pass |

CH00-DH1

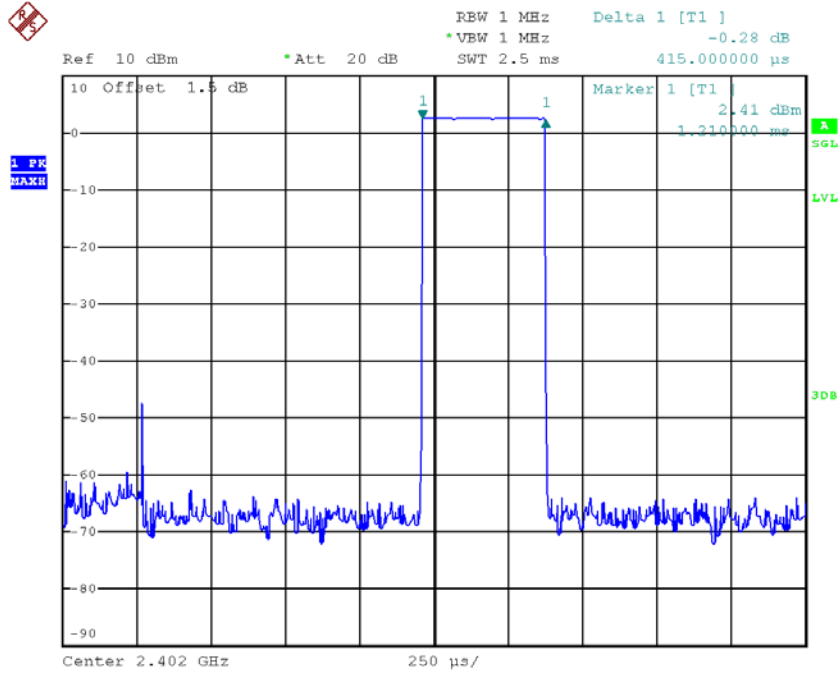

Date: 8.NOV.2017 10:59:15

CH00-DH3

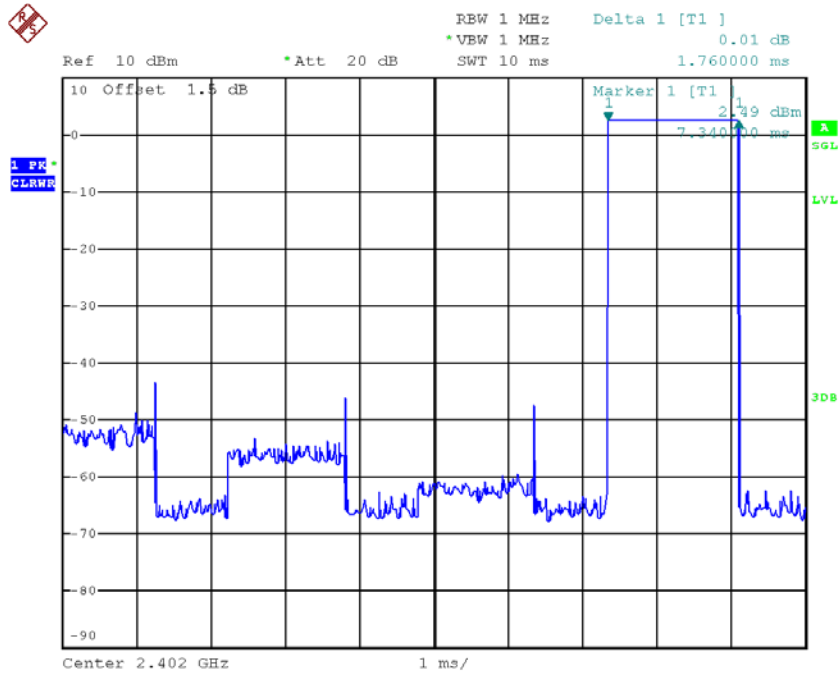

Date: 8.NOV.2017 11:07:39

CH00-DH5

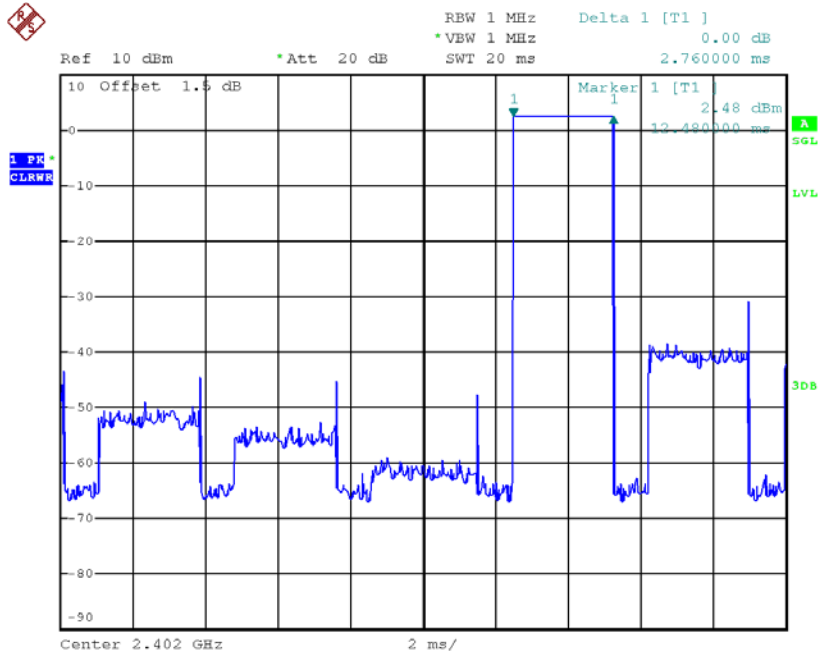

Date: 8.NOV.2017 11:08:05

CH39-DH1

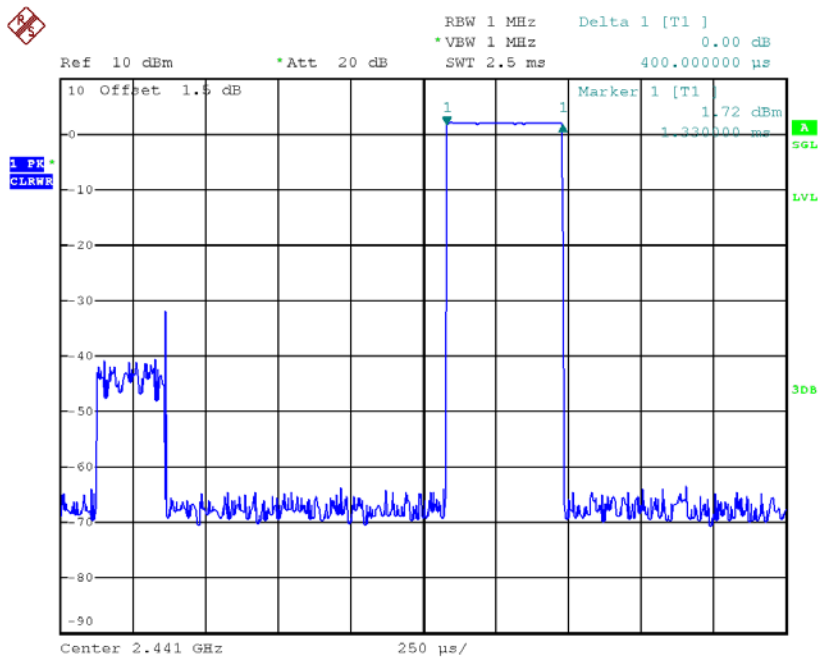

Date: 8.NOV.2017 11:00:03

CH39-DH3

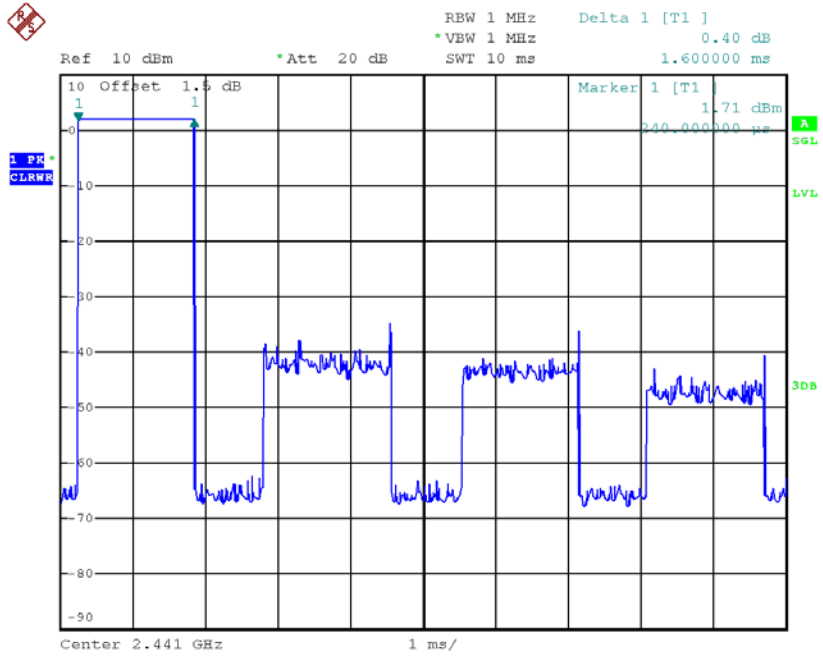

Date: 8.NOV.2017 11:07:03

CH39-DH5

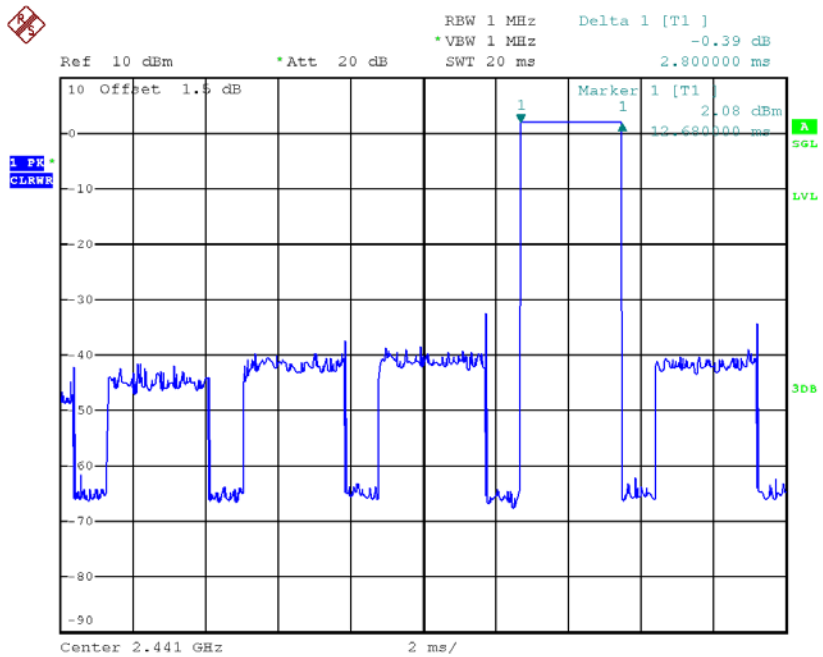

Date: 8.NOV.2017 11:08:09

CH78-DH1

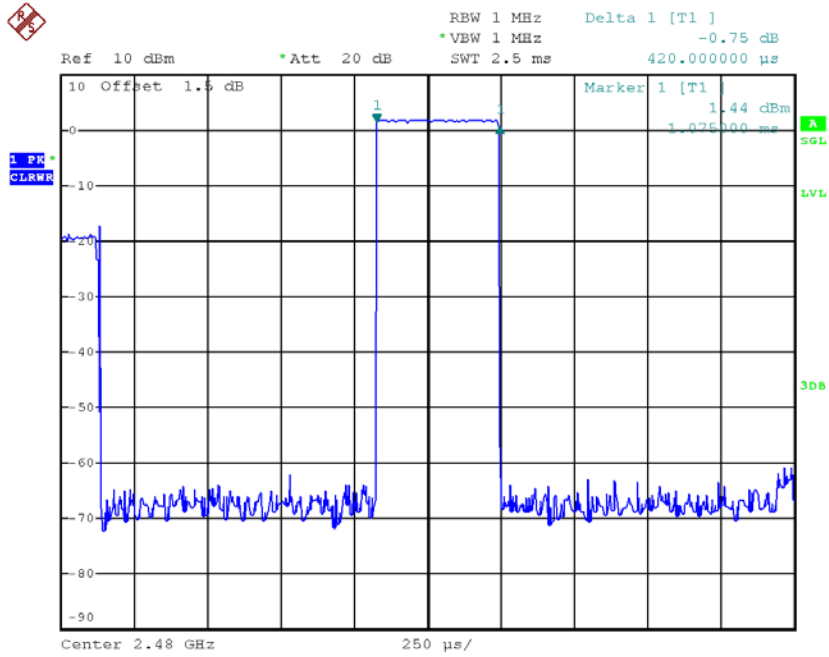

Date: 8.NOV.2017 11:00:35

CH78-DH3

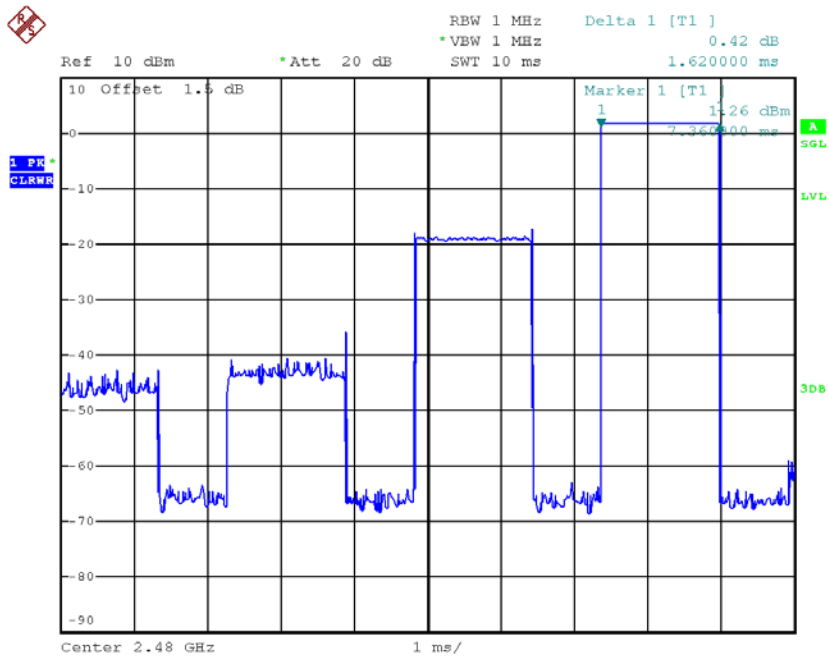

Date: 8.NOV.2017 11:07:44

CH78-DH5

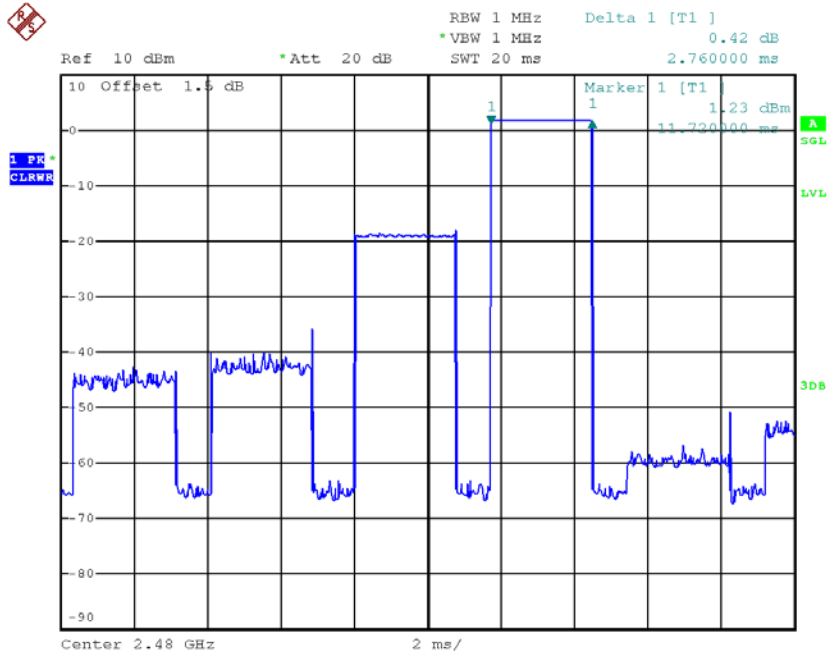

Date: 8.NOV.2017 11:08:33

| | |
|-------------|---------------|
| Test Mode : | TX Mode_3Mbps |
|-------------|---------------|

| Data Packet | Frequency | Pulse Duration(ms) | Dwell Time(s) | Limits(s) | Test Result |
|-------------|-----------|--------------------|---------------|-----------|-------------|
| DH5 | 2402 | 2.9600 | 0.3157 | 0.4000 | Pass |
| DH3 | 2402 | 1.7600 | 0.2816 | 0.4000 | Pass |
| DH1 | 2402 | 0.4000 | 0.1280 | 0.4000 | Pass |
| DH5 | 2441 | 2.7200 | 0.2901 | 0.4000 | Pass |
| DH3 | 2441 | 1.7600 | 0.2816 | 0.4000 | Pass |
| DH1 | 2441 | 0.4150 | 0.1328 | 0.4000 | Pass |
| DH5 | 2480 | 2.8000 | 0.2987 | 0.4000 | Pass |
| DH3 | 2480 | 1.5800 | 0.2528 | 0.4000 | Pass |
| DH1 | 2480 | 0.4200 | 0.1344 | 0.4000 | Pass |

CH00-DH1

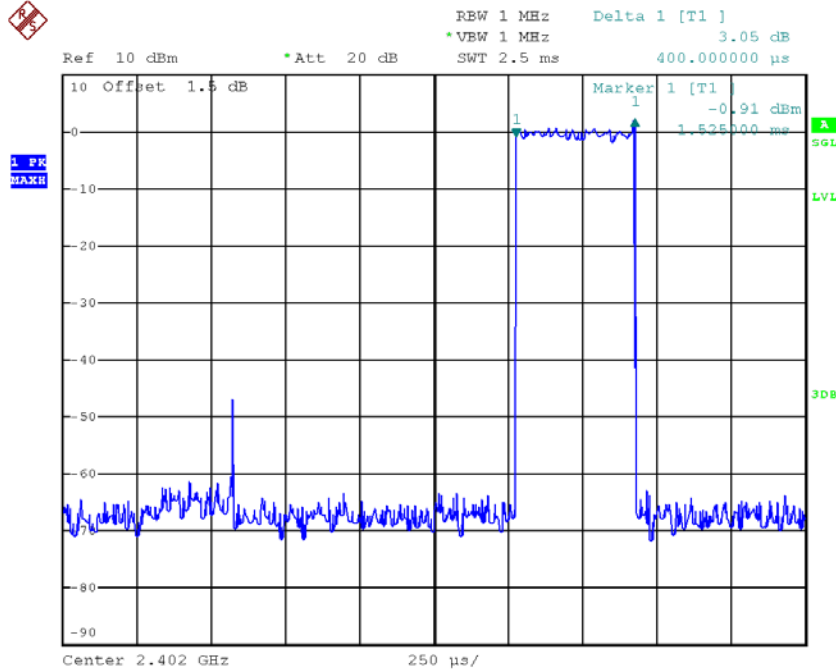

Date: 8.NOV.2017 11:12:39

CH00-DH3

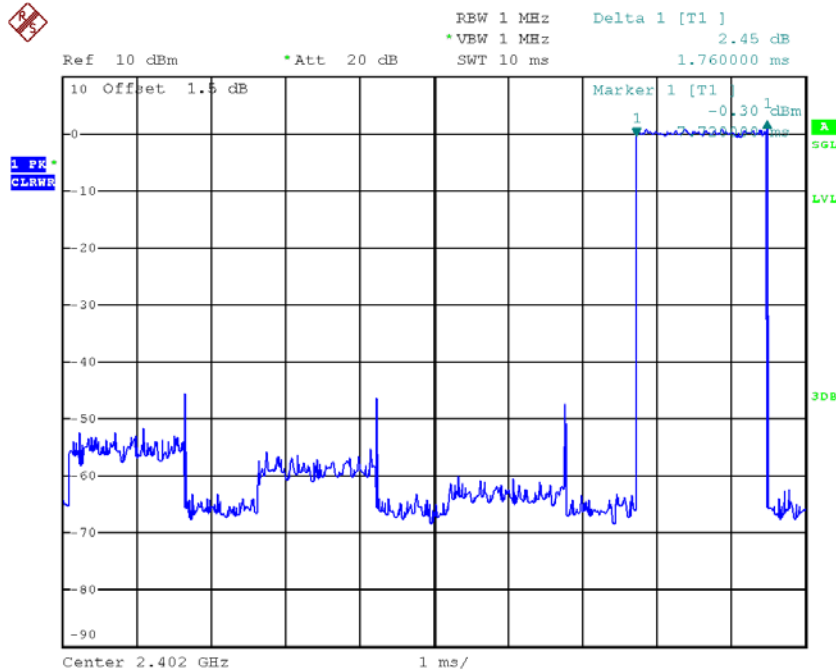

Date: 8.NOV.2017 11:30:20

CH00-DH5

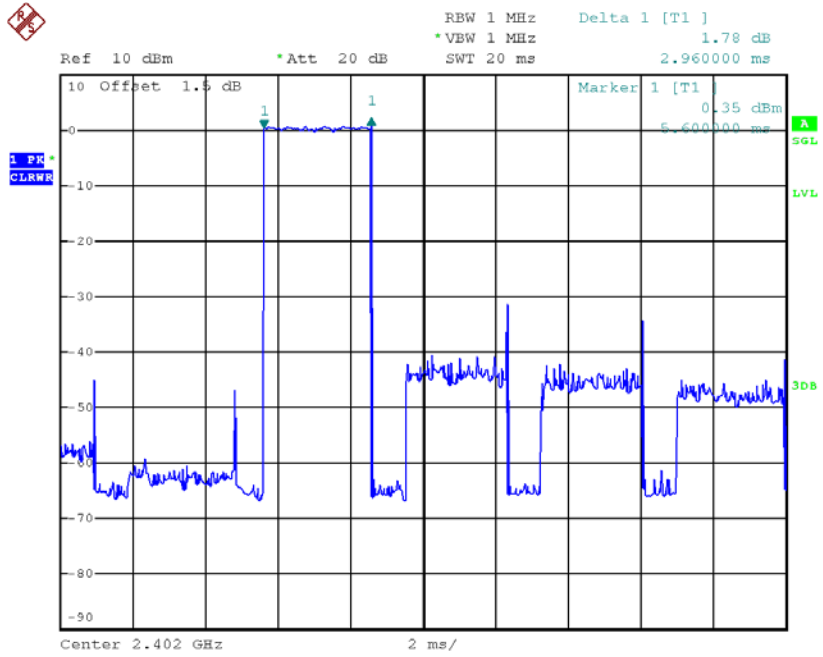

Date: 8.NOV.2017 11:30:40

CH39-DH1

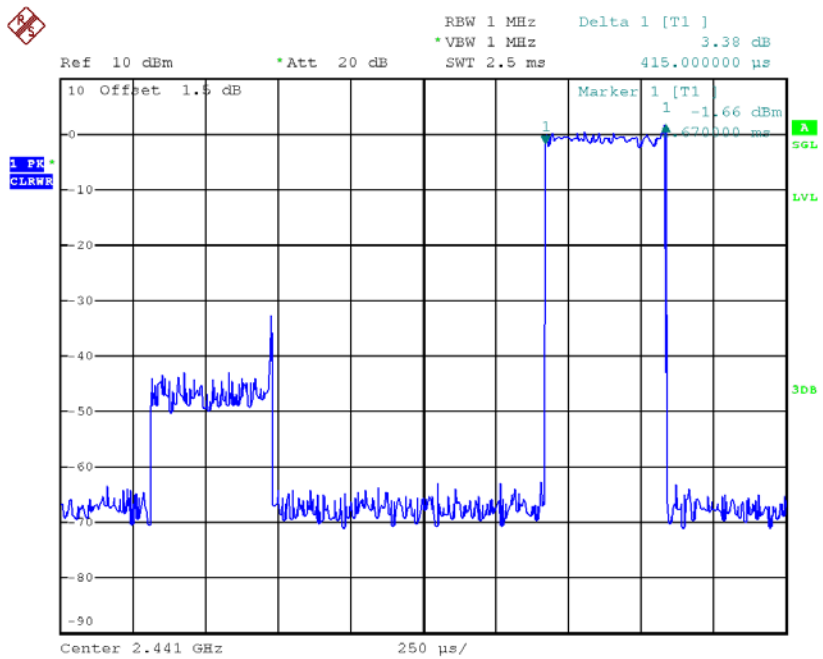

Date: 8.NOV.2017 11:13:45

CH39-DH3

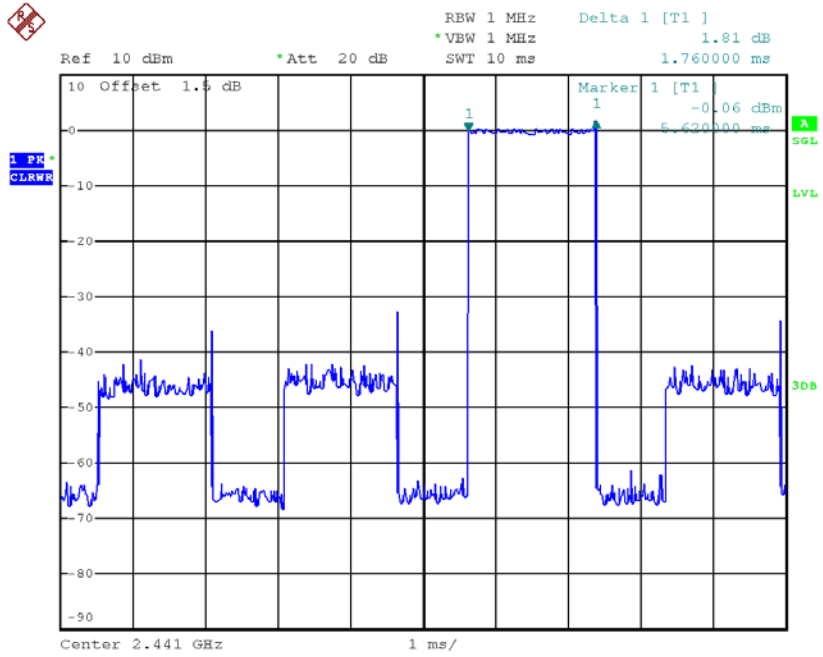

Date: 8.NOV.2017 11:30:03

CH39-DH5

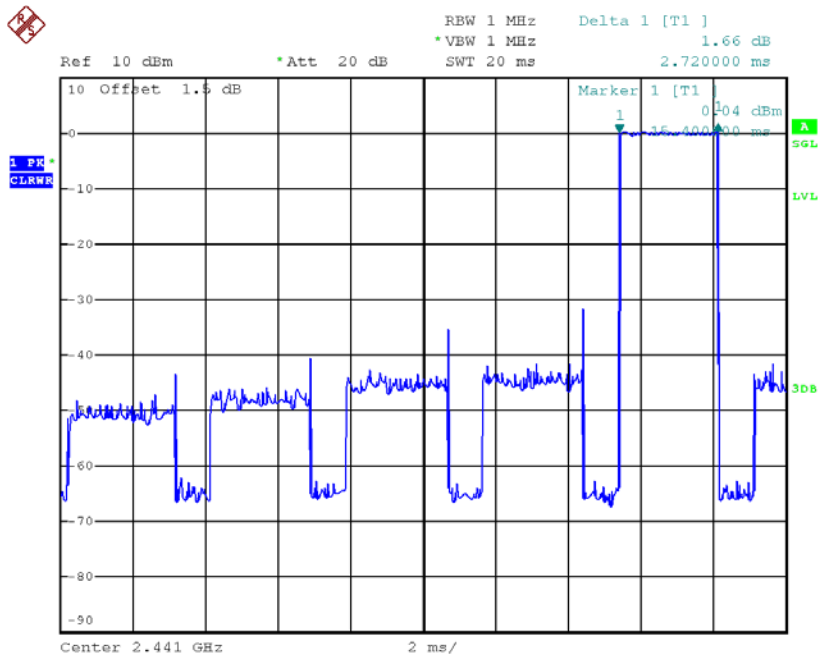

Date: 8.NOV.2017 11:31:16

CH78-DH1

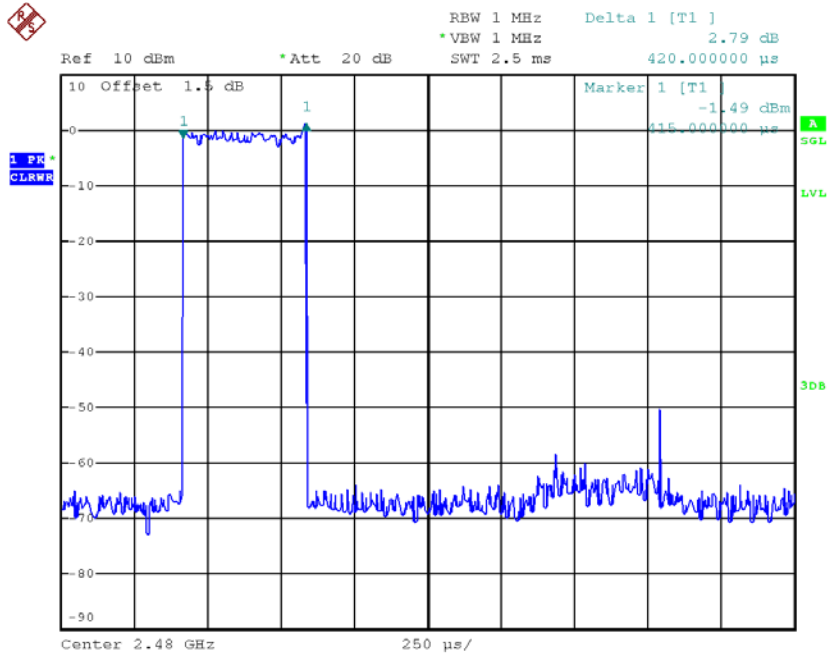

Date: 8.NOV.2017 11:13:15

CH78-DH3

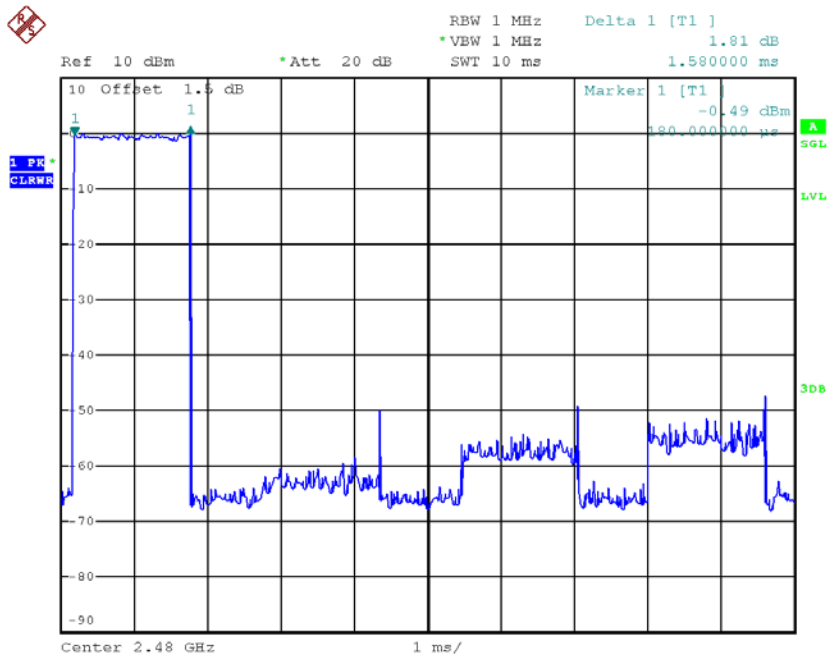

Date: 8.NOV.2017 11:30:24

CH78-DH5

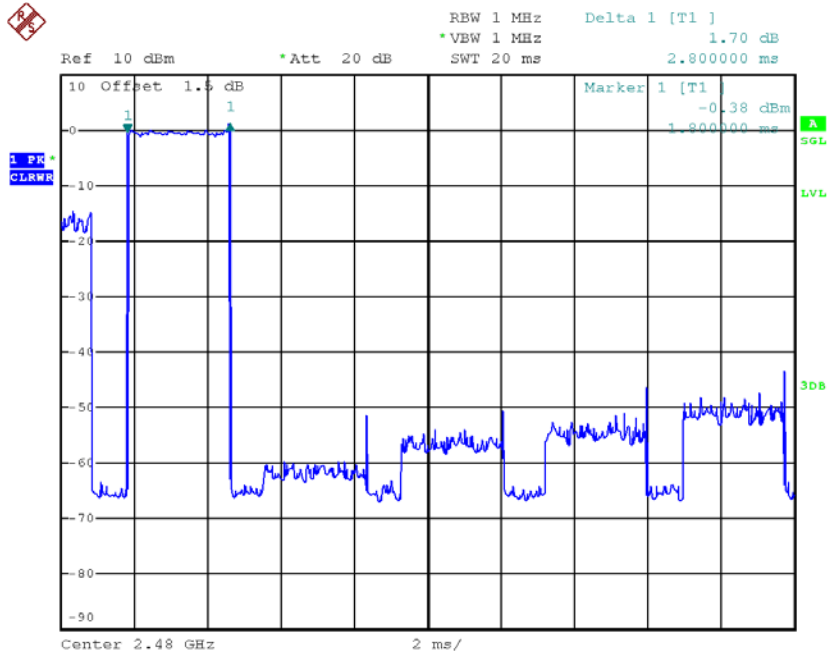

Date: 8.NOV.2017 11:30:47

APPENDIX G - HOPPING CHANNEL SEPARATION MEASUREMENT

Test Mode : Hopping on _1Mbps

| Frequency (MHz) | Channel Separation (MHz) | 2/3 of 20dB Bandwidth (MHz) | Test Result |
|-----------------|--------------------------|-----------------------------|-------------|
| 2402 | 0.950 | 0.692 | Pass |
| 2441 | 0.918 | 0.728 | Pass |
| 2480 | 0.990 | 0.688 | Pass |

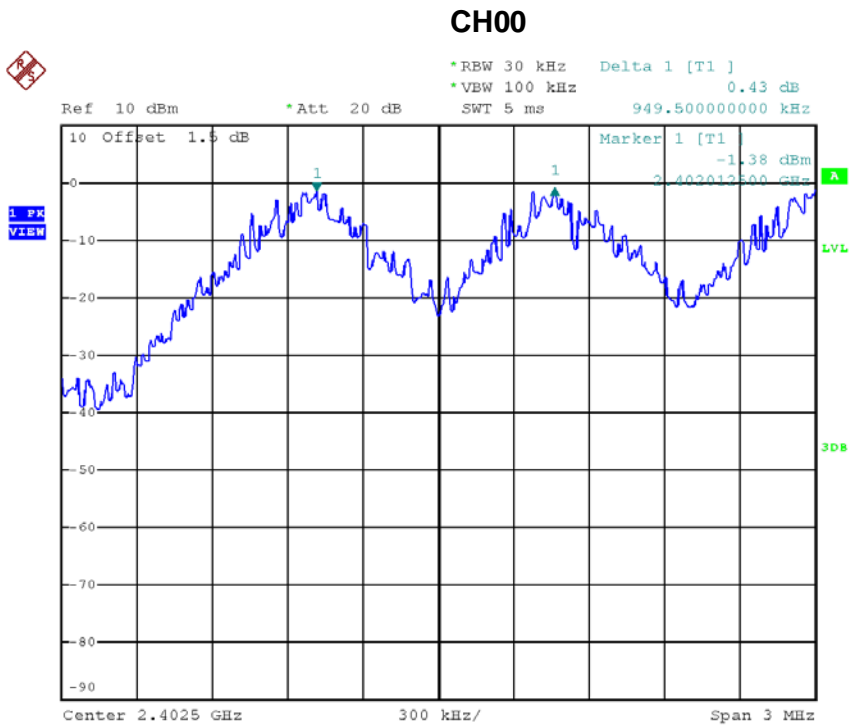

Date: 8.NOV.2017 11:01:42

CH39

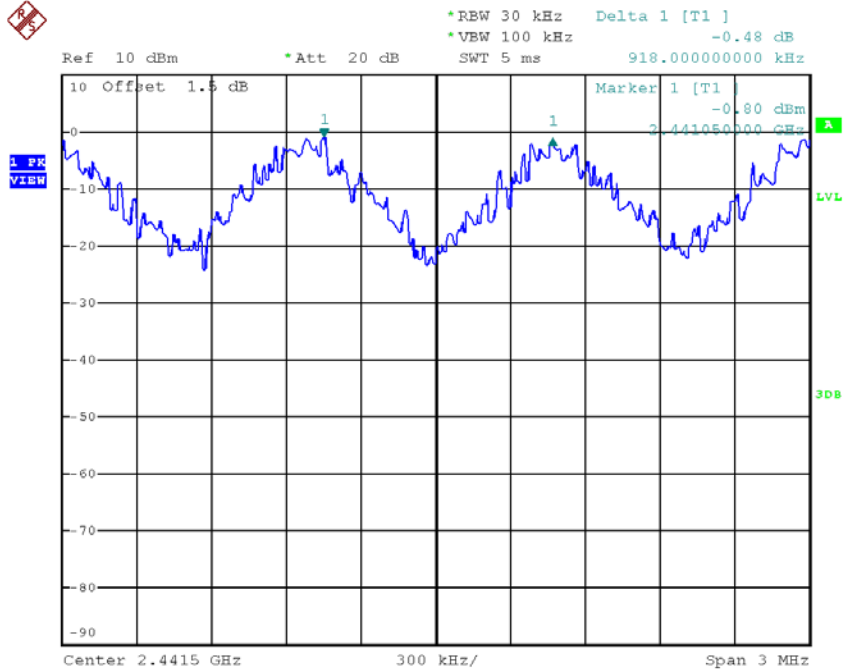

Date: 8.NOV.2017 11:02:45

CH78

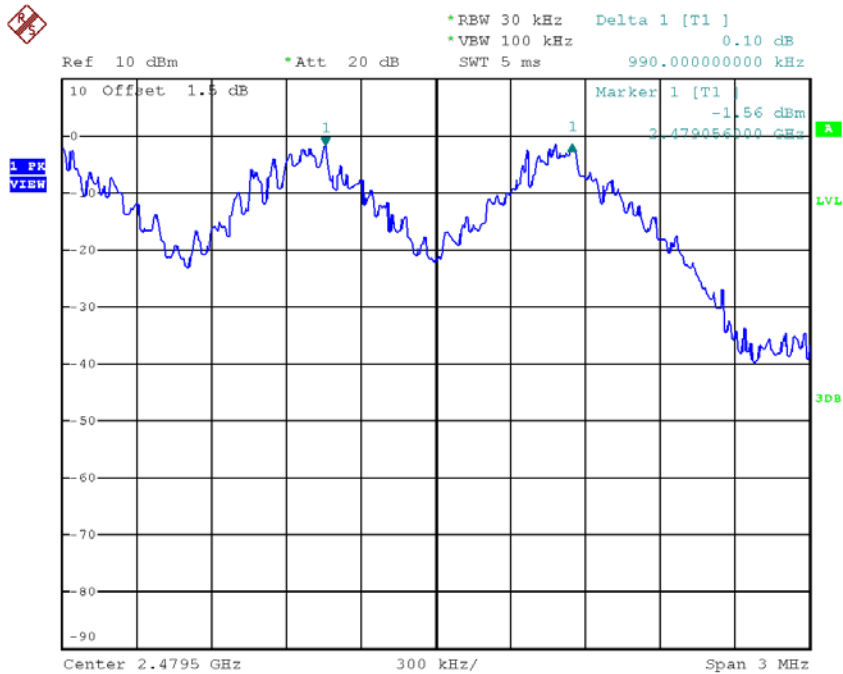

Date: 8.NOV.2017 11:03:49

Test Mode : Hopping on _3Mbps

| Frequency (MHz) | Channel Separation (MHz) | 2/3 of 20dB Bandwidth (MHz) | Test Result |
|-----------------|--------------------------|-----------------------------|-------------|
| 2402 | 1.022 | 0.917 | Pass |
| 2441 | 1.002 | 0.912 | Pass |
| 2480 | 1.032 | 0.911 | Pass |

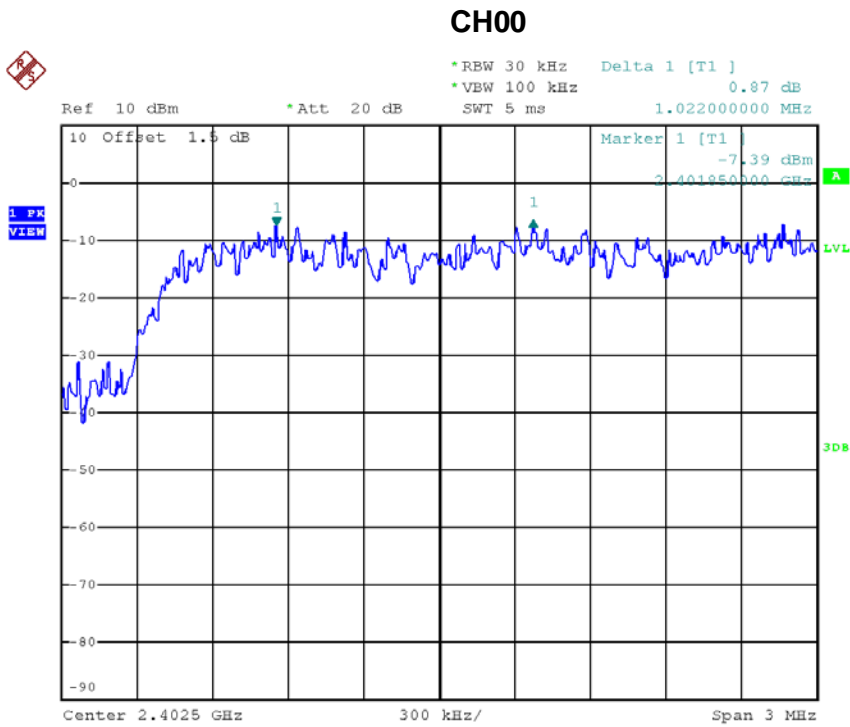

Date: 8.NOV.2017 11:17:24

CH39

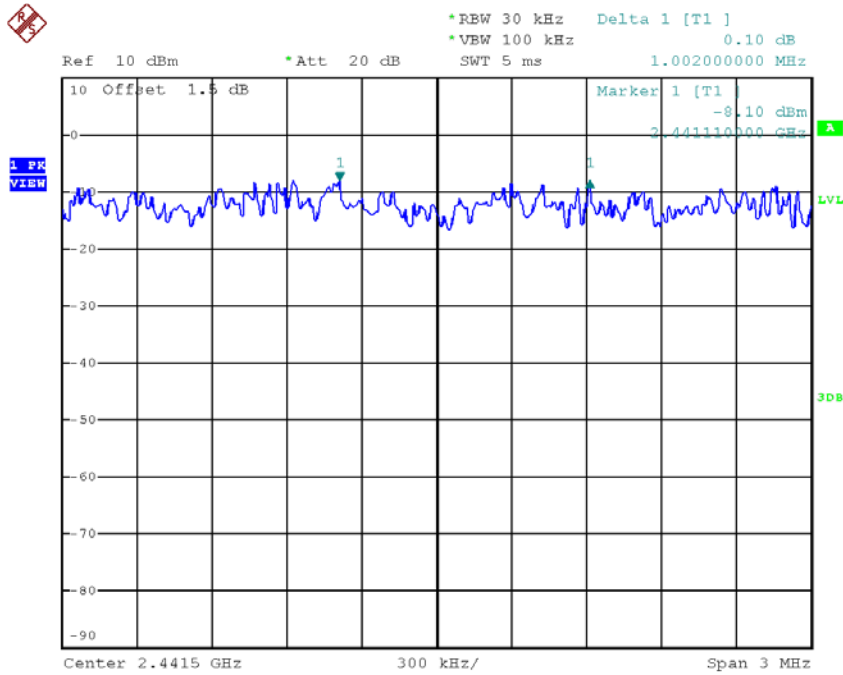

Date: 8.NOV.2017 11:24:33

CH78

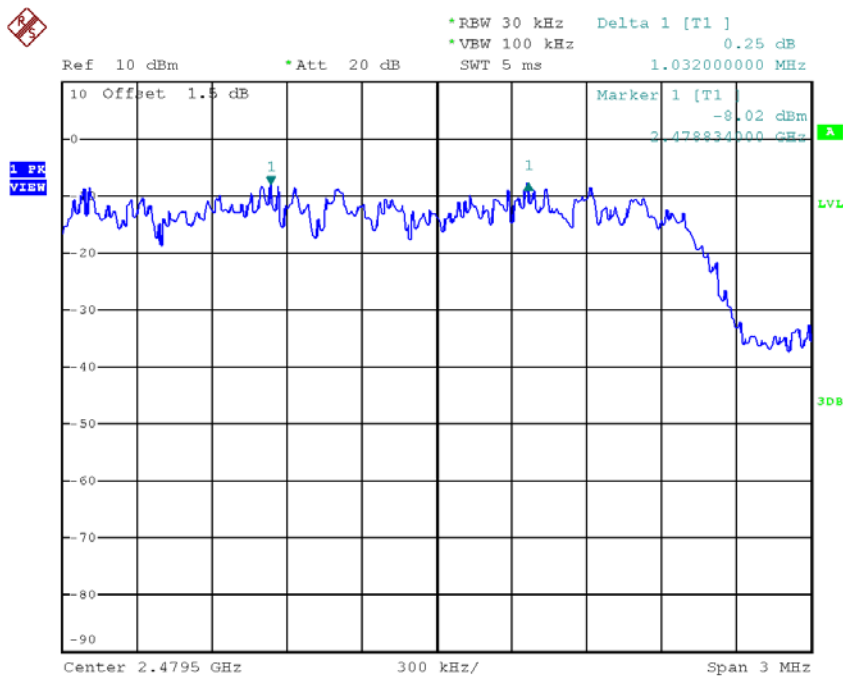

Date: 8.NOV.2017 11:29:02

APPENDIX H - BANDWIDTH

Test Mode : TX Mode _1Mbps

| Frequency (MHz) | 20dB Bandwidth (MHz) | 99% Occupied BW (MHz) | Test Result |
|-----------------|----------------------|-----------------------|-------------|
| 2402 | 1.038 | 0.944 | Pass |
| 2441 | 1.092 | 0.944 | Pass |
| 2480 | 1.032 | 0.940 | Pass |

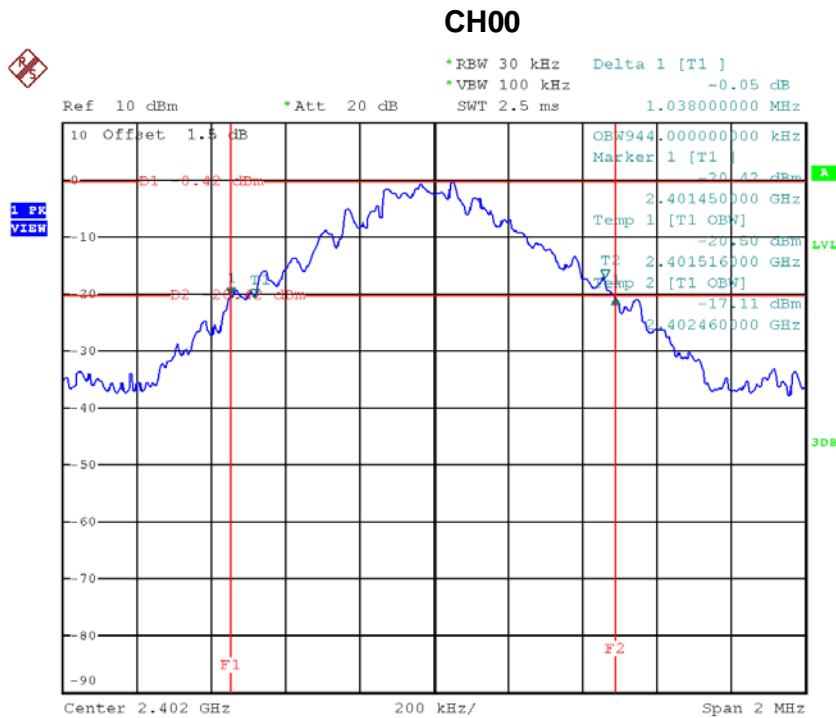

Date: 8.NOV.2017 10:53:19

CH39

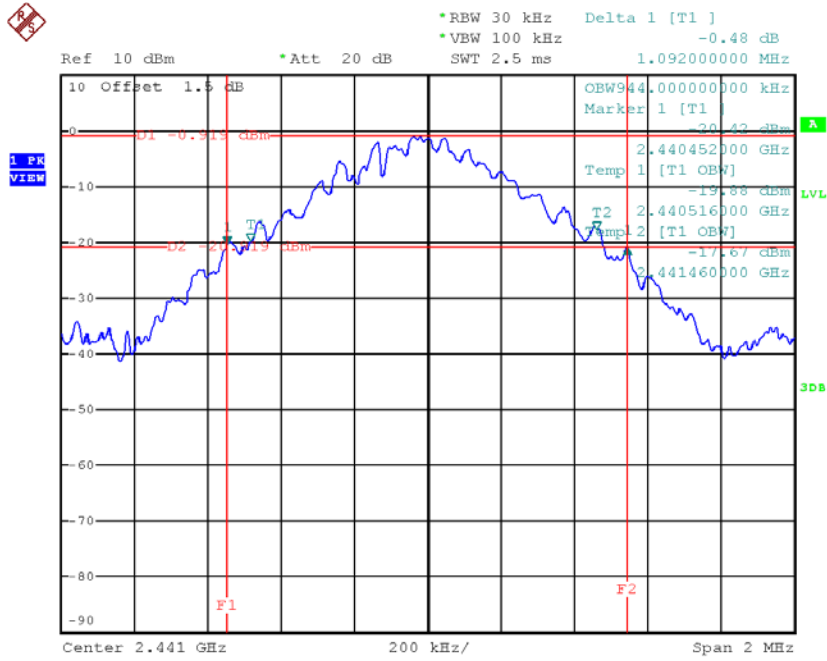

Date: 8.NOV.2017 10:56:56

CH78

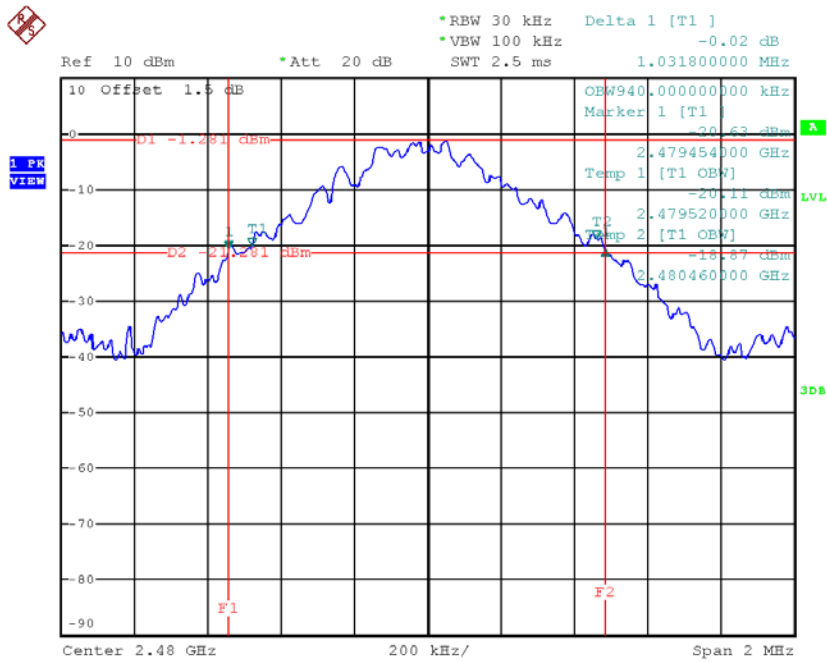

Date: 8.NOV.2017 10:57:51

Test Mode : TX Mode _3Mbps

| Frequency (MHz) | 20dB Bandwidth (MHz) | 99% Occupied BW (MHz) | Test Result |
|-----------------|----------------------|-----------------------|-------------|
| 2402 | 1.376 | 1.252 | Pass |
| 2441 | 1.368 | 1.244 | Pass |
| 2480 | 1.366 | 1.240 | Pass |

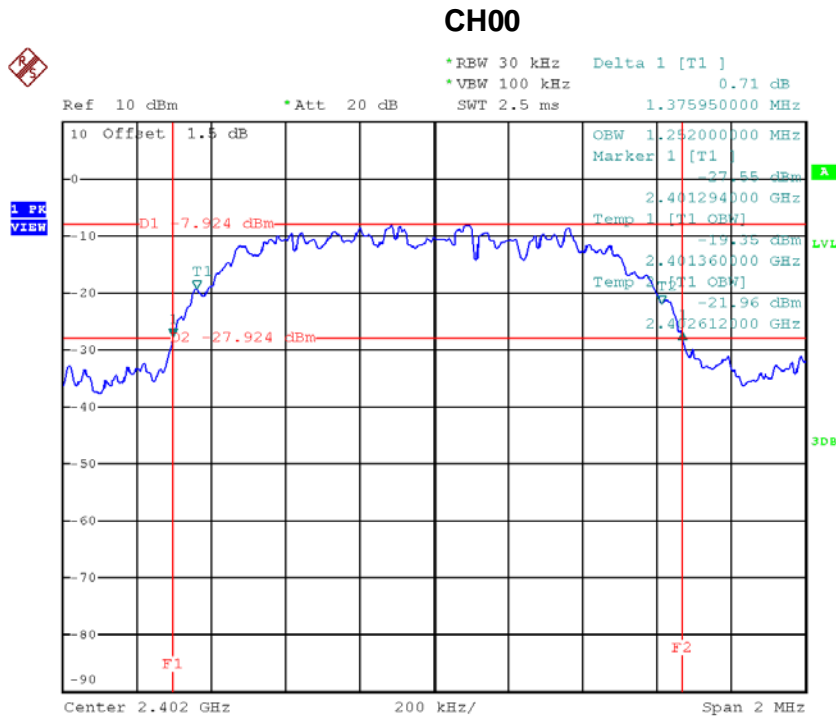

Date: 8.NOV.2017 11:09:36

CH39

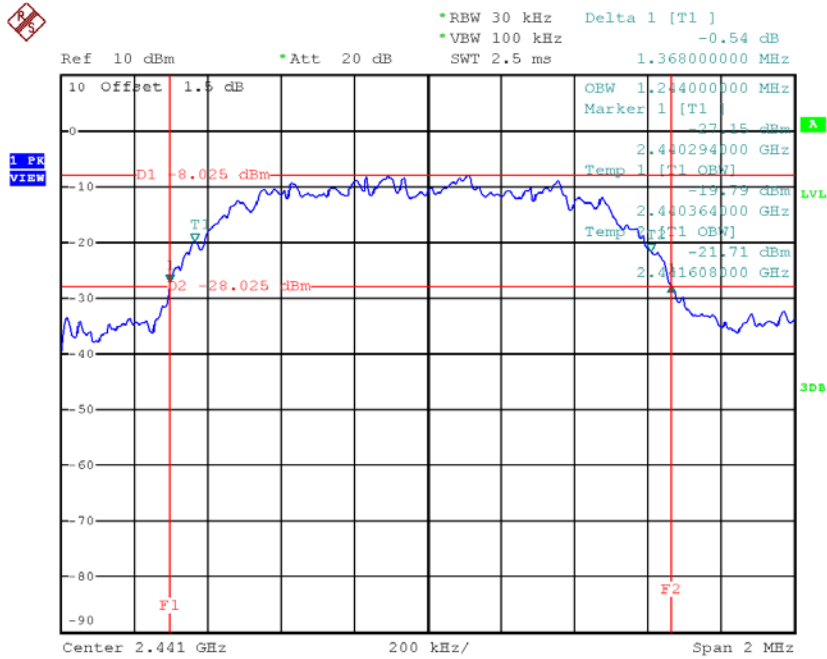

Date: 8.NOV.2017 11:11:08

CH78

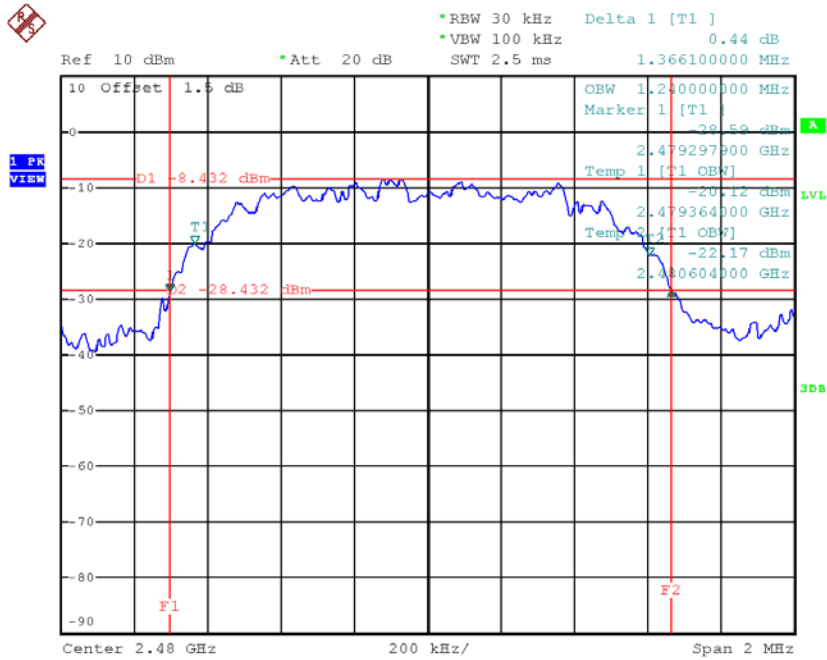

Date: 8.NOV.2017 11:11:46

APPENDIX I - PEAK OUTPUT POWER

Test Mode : TX Mode _1Mbps

| Frequency (MHz) | Conducted Power (dBm) | Conducted Power (W) | Max. Limit (dBm) | Max. Limit (W) | Test Result |
|-----------------|-----------------------|---------------------|------------------|----------------|-------------|
| 2402 | 2.59 | 0.0018 | 30.00 | 1.00 | Pass |
| 2441 | 2.22 | 0.0017 | 30.00 | 1.00 | Pass |
| 2480 | 1.82 | 0.0015 | 30.00 | 1.00 | Pass |

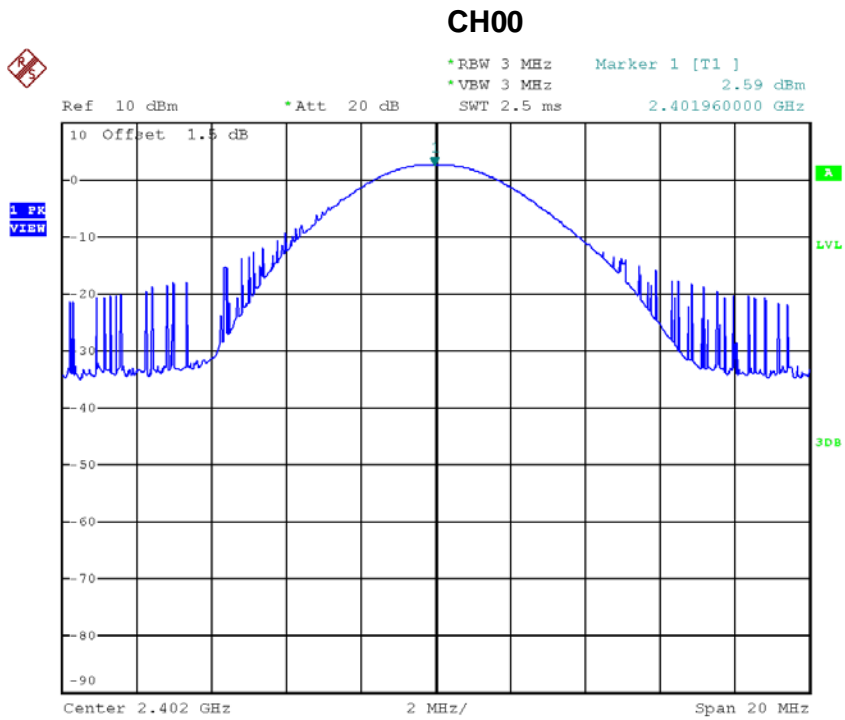

Date: 8.NOV.2017 10:53:52

CH39

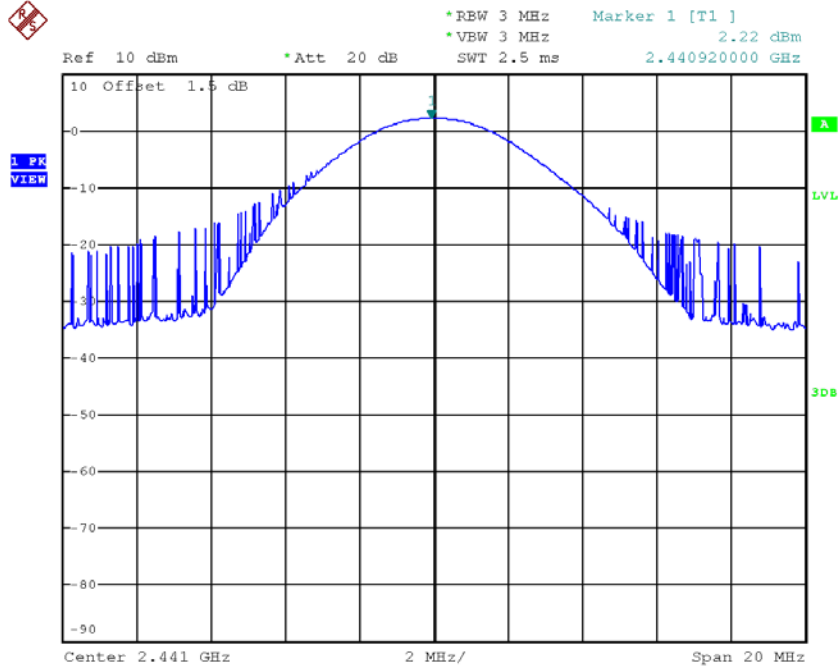

Date: 8.NOV.2017 10:57:01

CH78

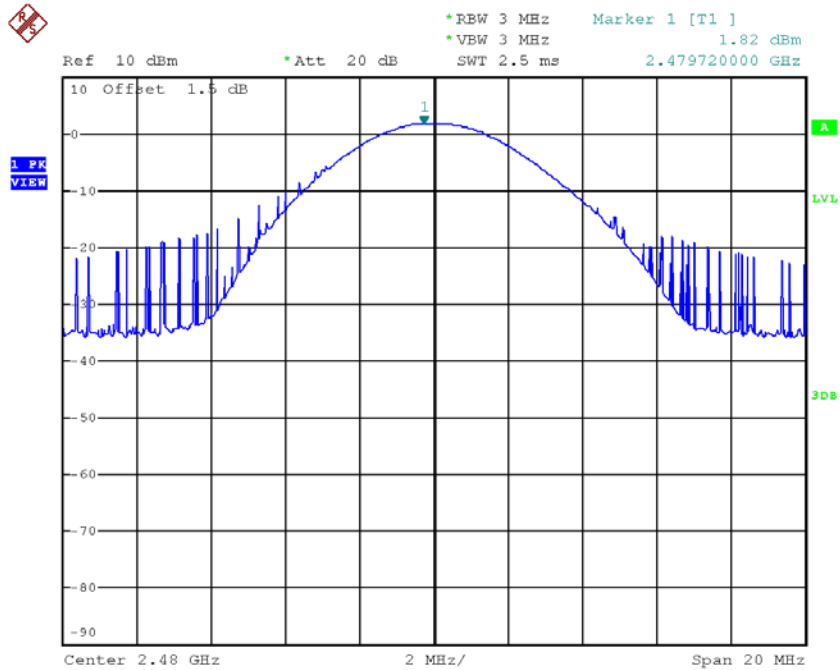

Date: 8.NOV.2017 10:58:24

Test Mode : TX Mode _3Mbps

| Frequency (MHz) | Conducted Power (dBm) | Conducted Power (W) | Max. Limit (dBm) | Max. Limit (W) | Test Result |
|-----------------|-----------------------|---------------------|------------------|----------------|-------------|
| 2402 | 2.53 | 0.0018 | 30.00 | 1.00 | Pass |
| 2441 | 2.18 | 0.0017 | 30.00 | 1.00 | Pass |
| 2480 | 1.74 | 0.0015 | 30.00 | 1.00 | Pass |

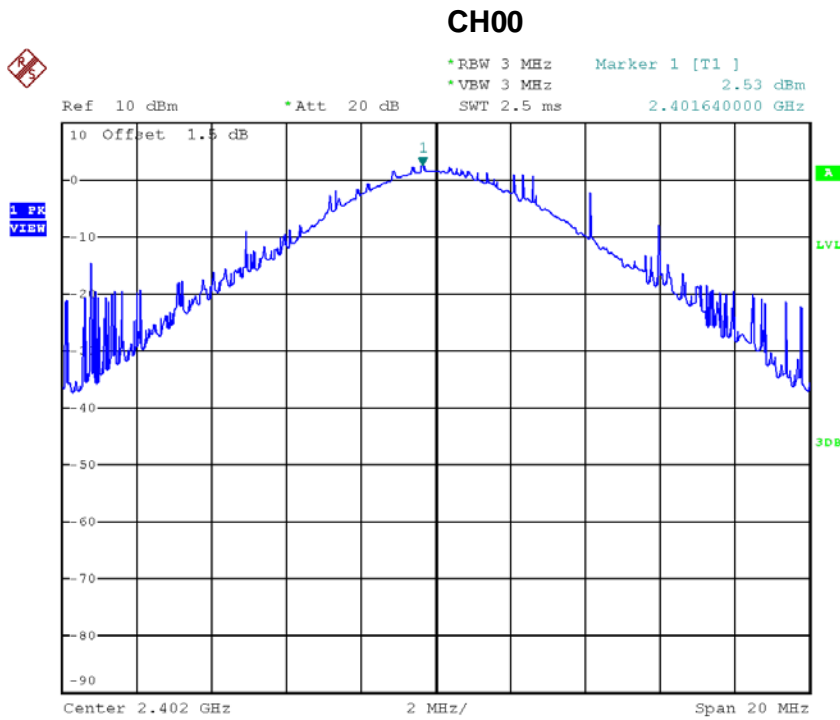

Date: 8.NOV.2017 11:10:09

CH39

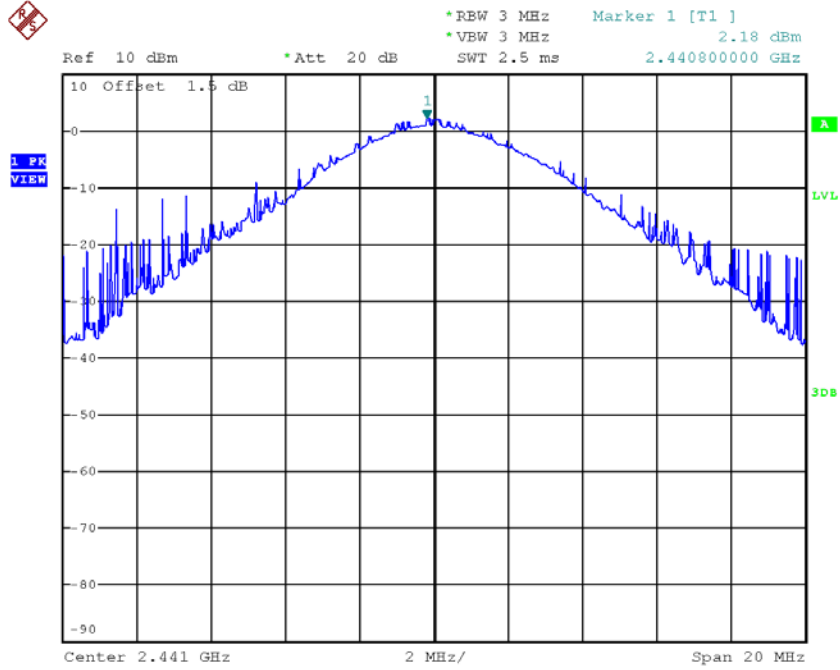

Date: 8.NOV.2017 11:11:14

CH78

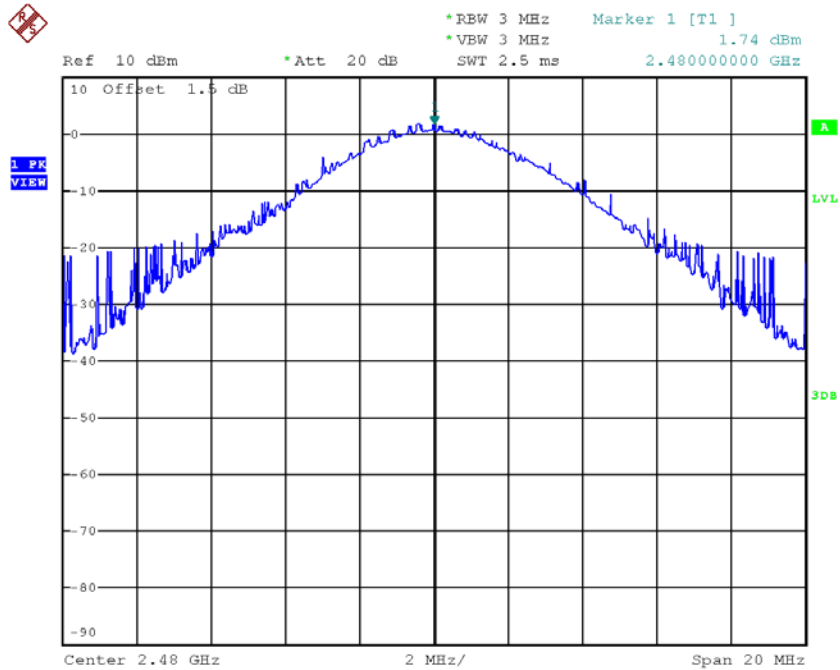

Date: 8.NOV.2017 11:12:18

APPENDIX J - ANTENNA CONDUCTED SPURIOUS EMISSION

CH00 (Lower)_1Mbps

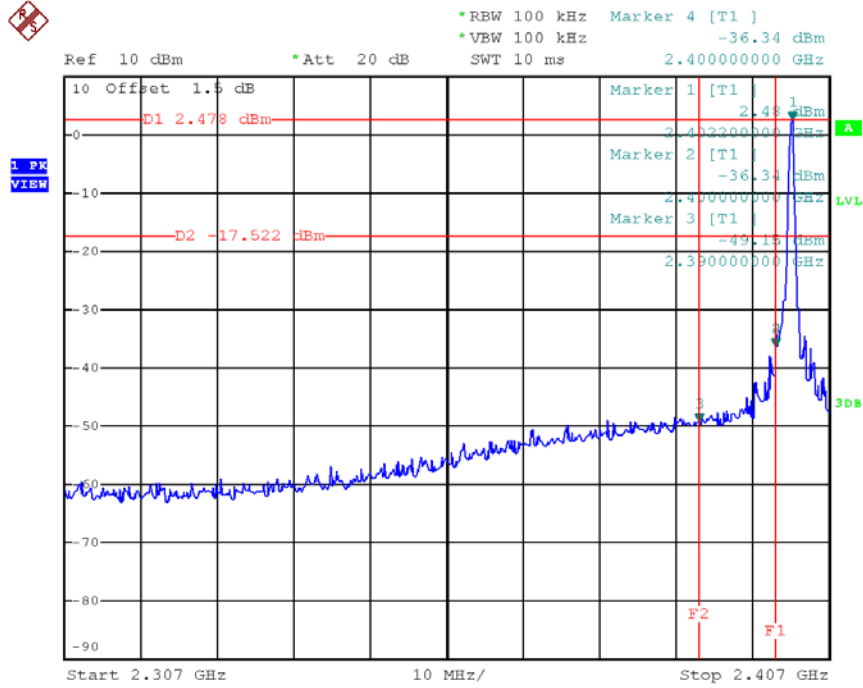

Date: 8.NOV.2017 10:52:57

CH78 (Upper)_1Mbps

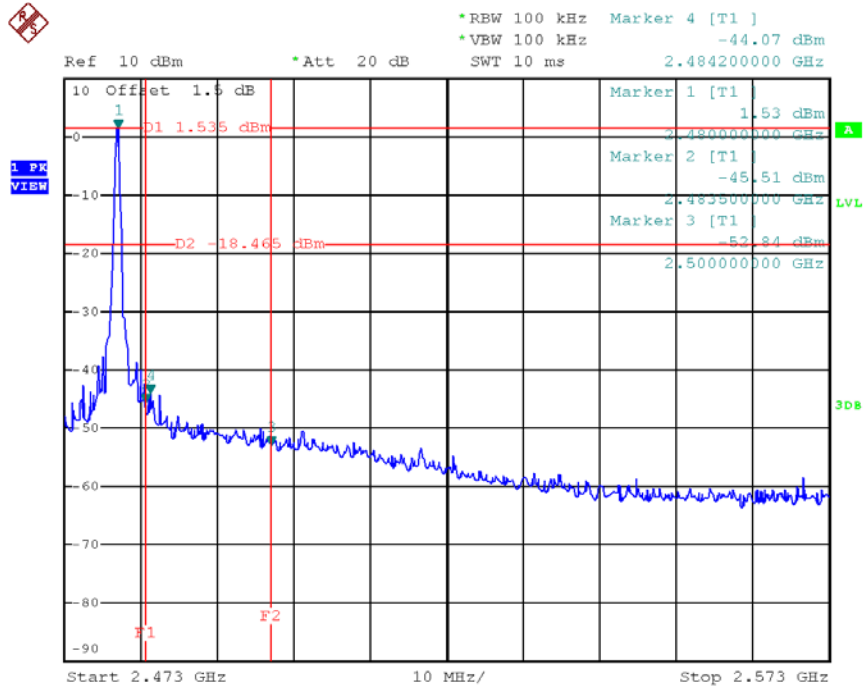

Date: 8.NOV.2017 10:57:29

CH00 Hopping on mode (Lower)_1Mbps

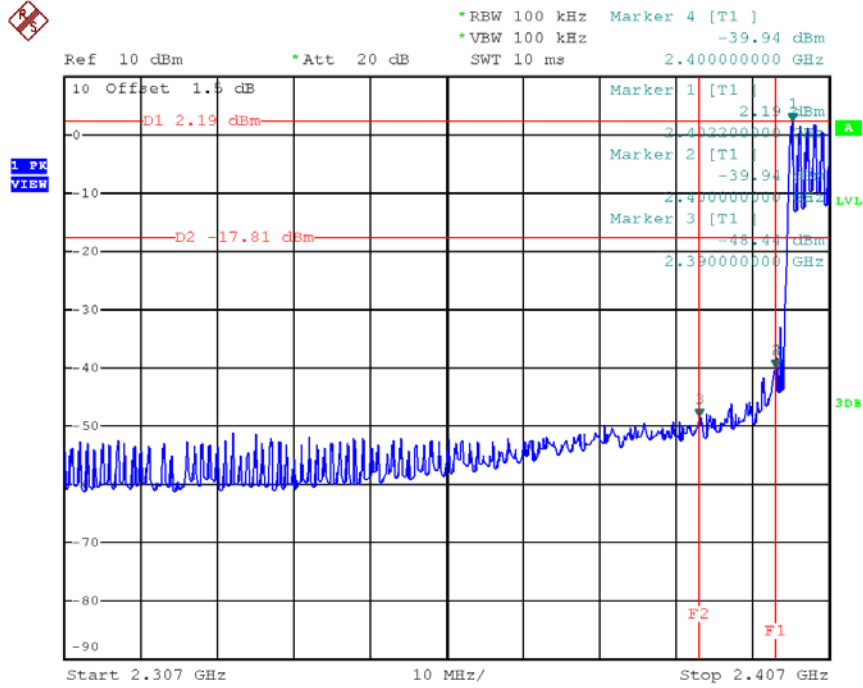

Date: 8.NOV.2017 11:06:11

CH78 Hopping on mode (Upper)_1Mbps

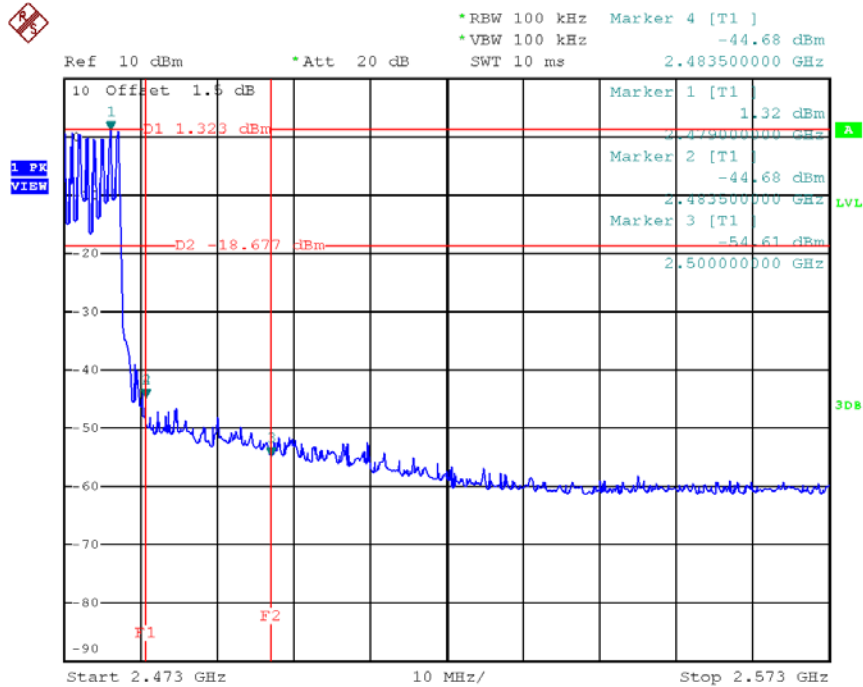

Date: 8.NOV.2017 11:06:45

CH00 (10 Harmonic of the frequency) _1Mbps

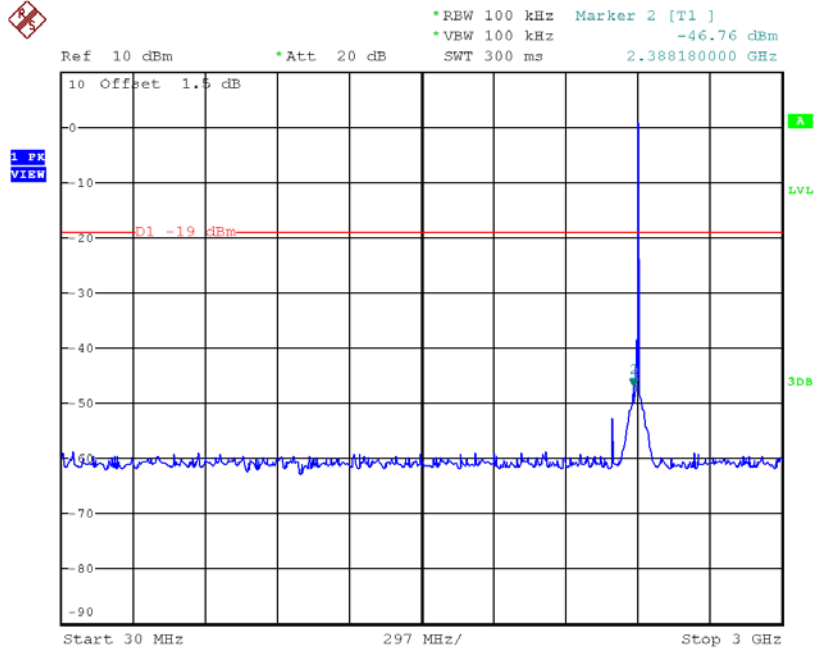

Date: 8.NOV.2017 10:53:32

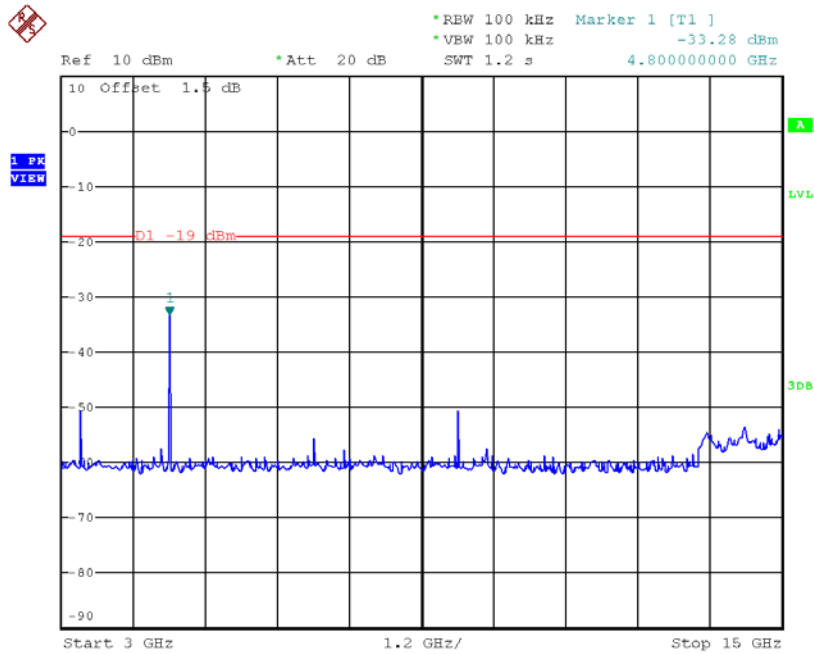

Date: 8.NOV.2017 10:53:39

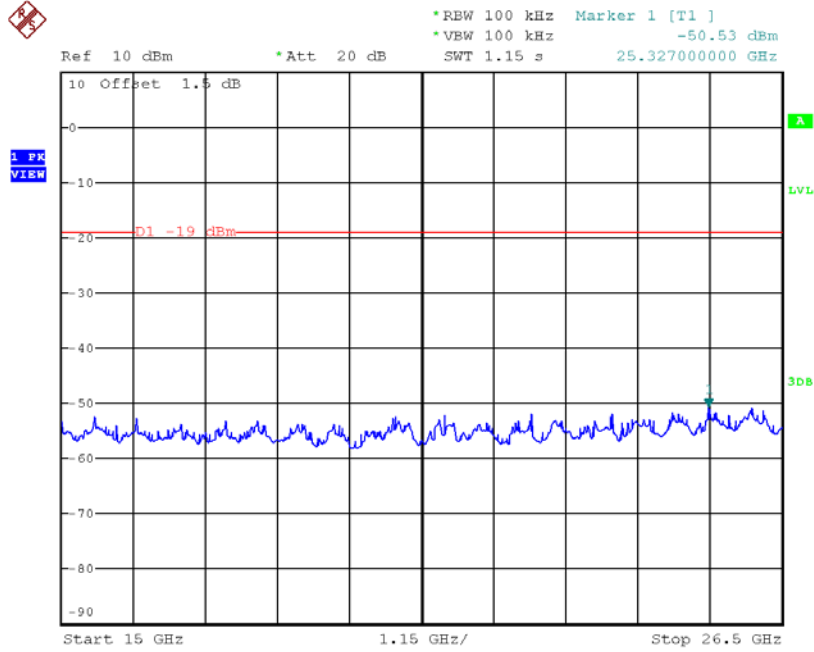

Date: 8.NOV.2017 10:53:46

CH39 (10 Harmonic of the frequency) _1Mbps

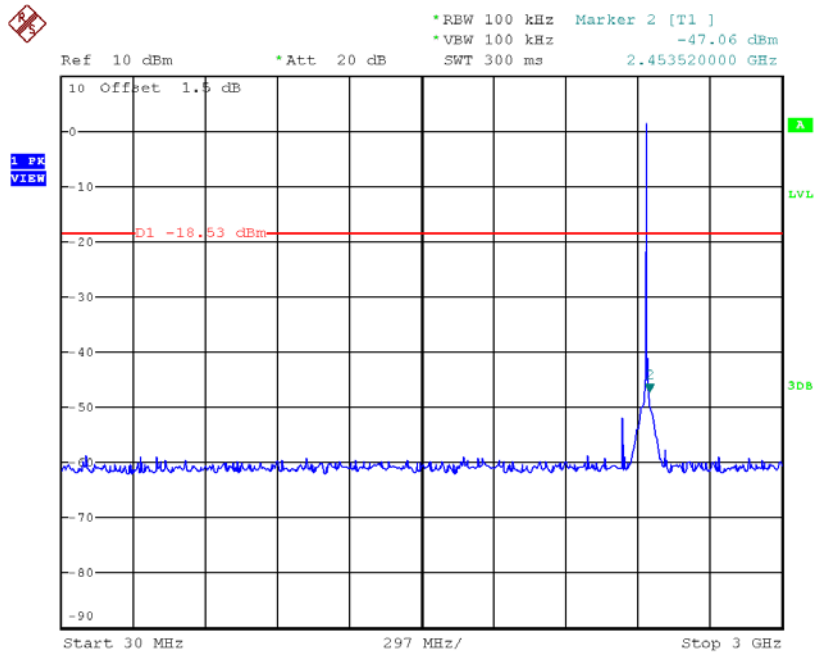

Date: 8.NOV.2017 10:56:22

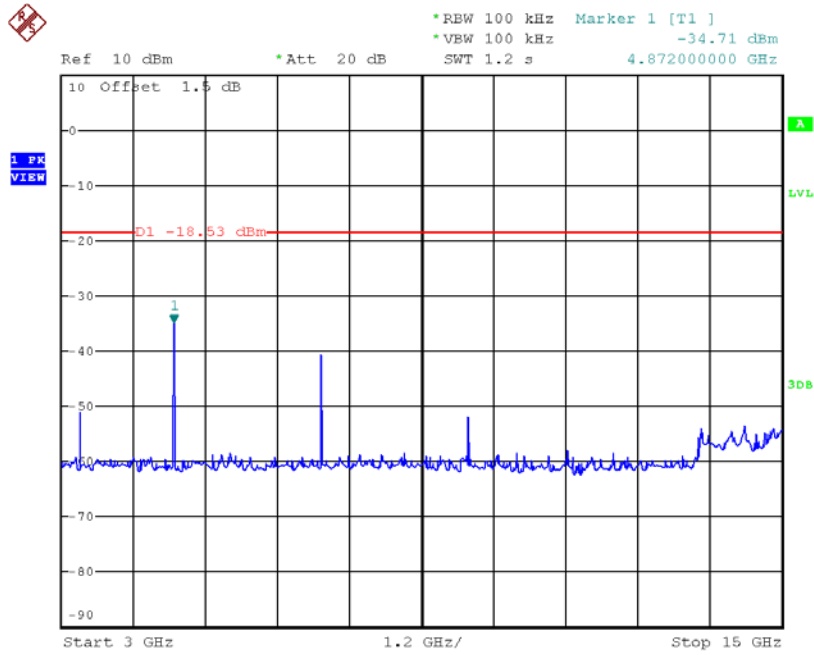

Date: 8.NOV.2017 10:56:29

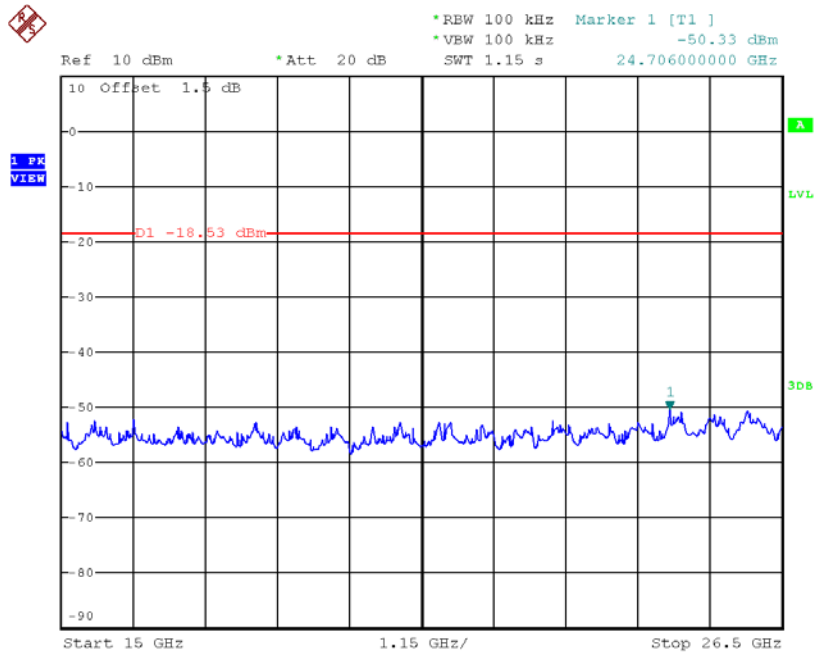

Date: 8.NOV.2017 10:56:36

CH78 (10 Harmonic of the frequency) _1Mbps

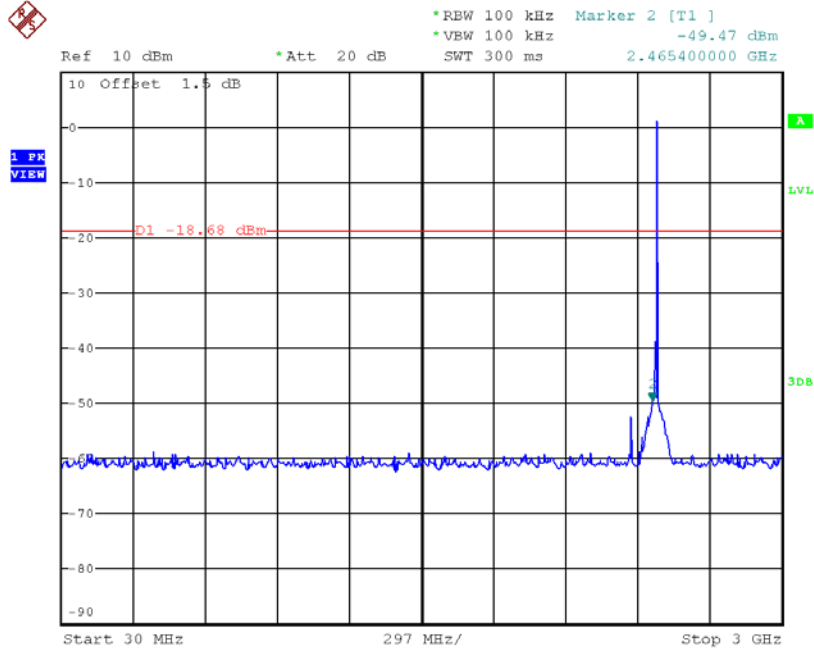

Date: 8.NOV.2017 10:58:04

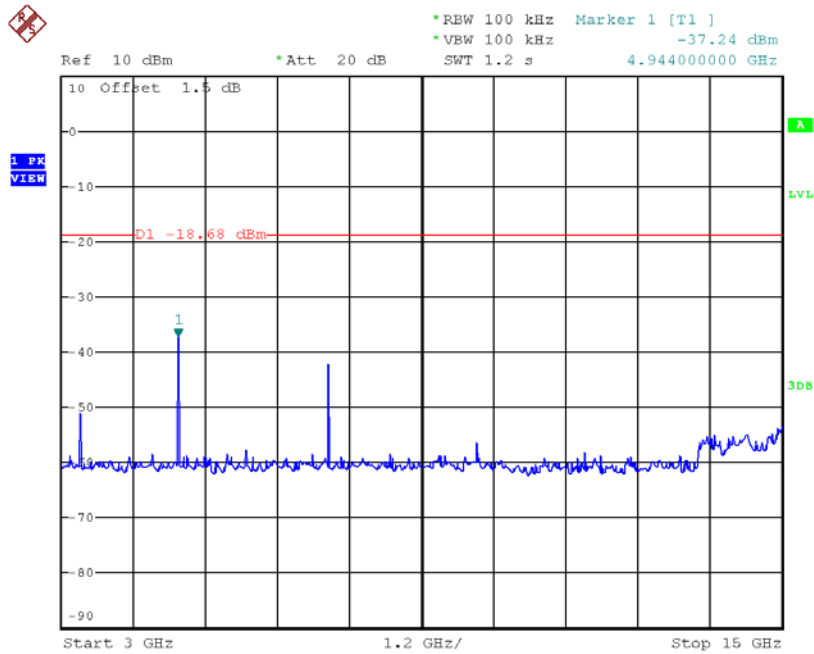

Date: 8.NOV.2017 10:58:11

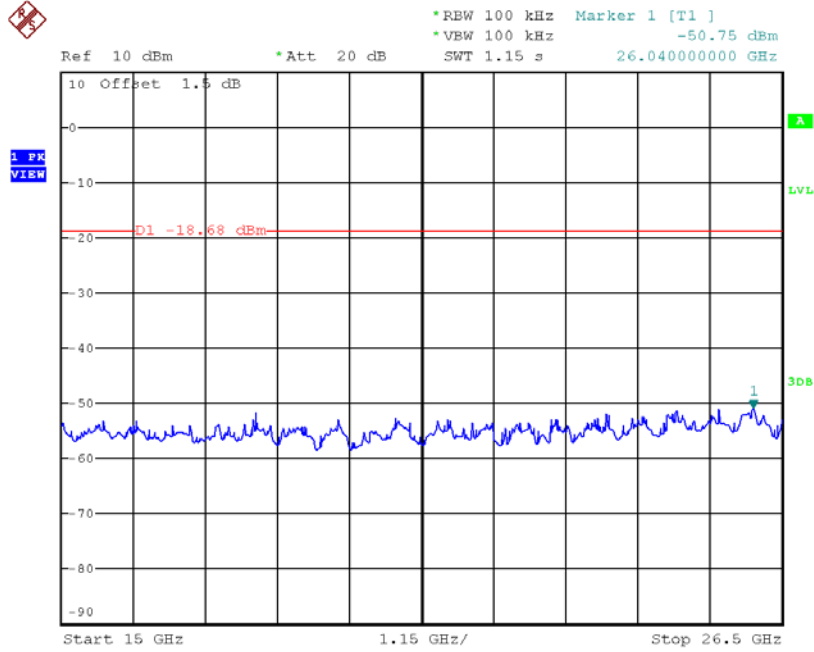

Date: 8.NOV.2017 10:58:18

CH00 (Lower) _3Mbps

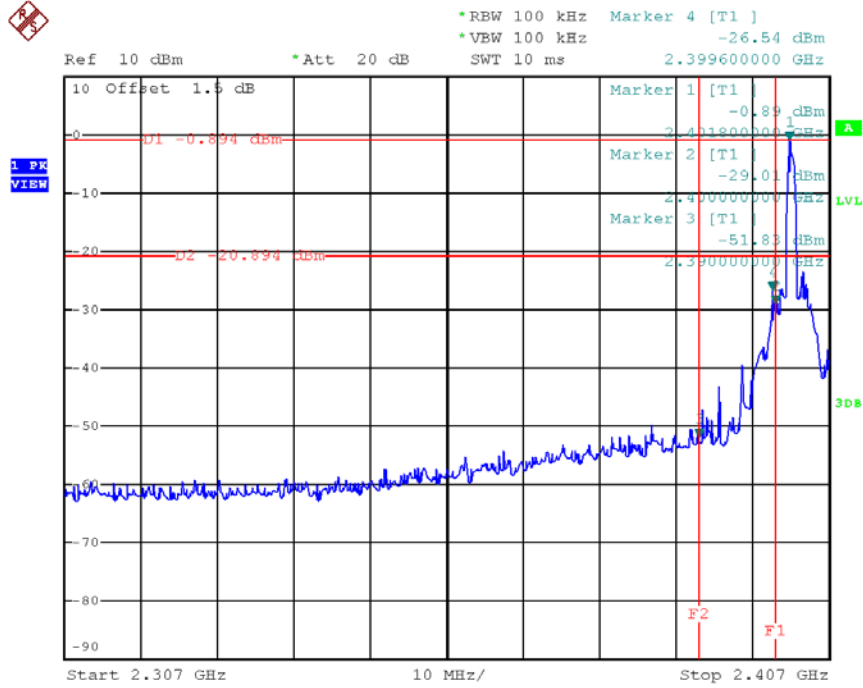

Date: 8.NOV.2017 11:09:21

CH78 (Upper) _3Mbps

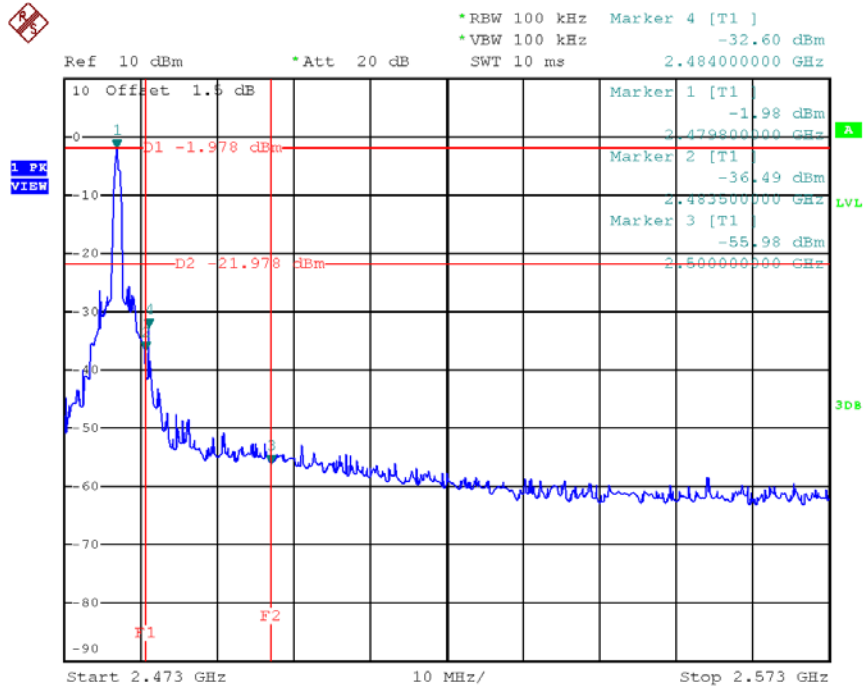

Date: 8.NOV.2017 11:11:30

CH00 Hopping on mode (Lower)_3Mbps

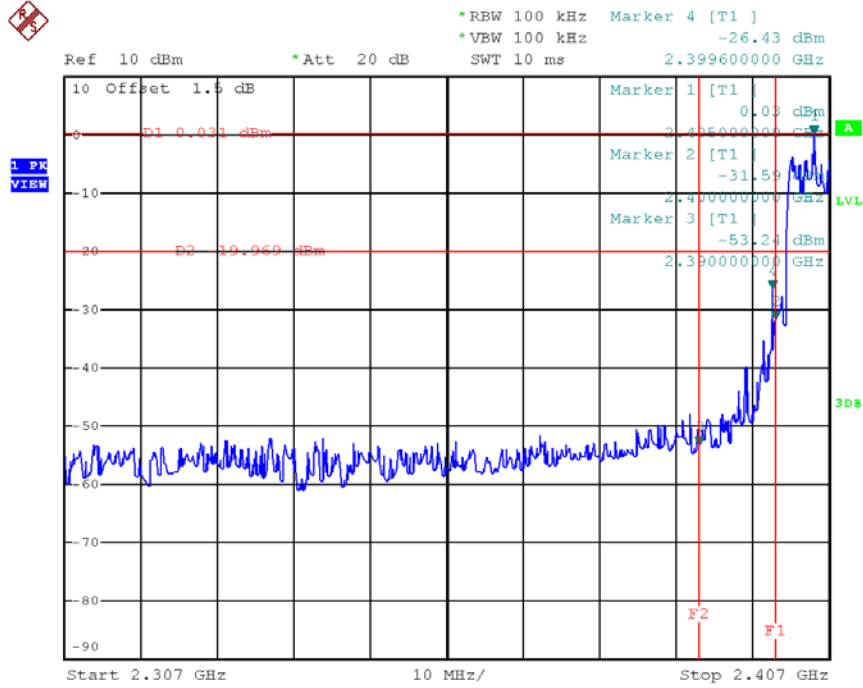

Date: 8.NOV.2017 11:29:36

CH78 Hopping on mode (Upper)_3Mbps

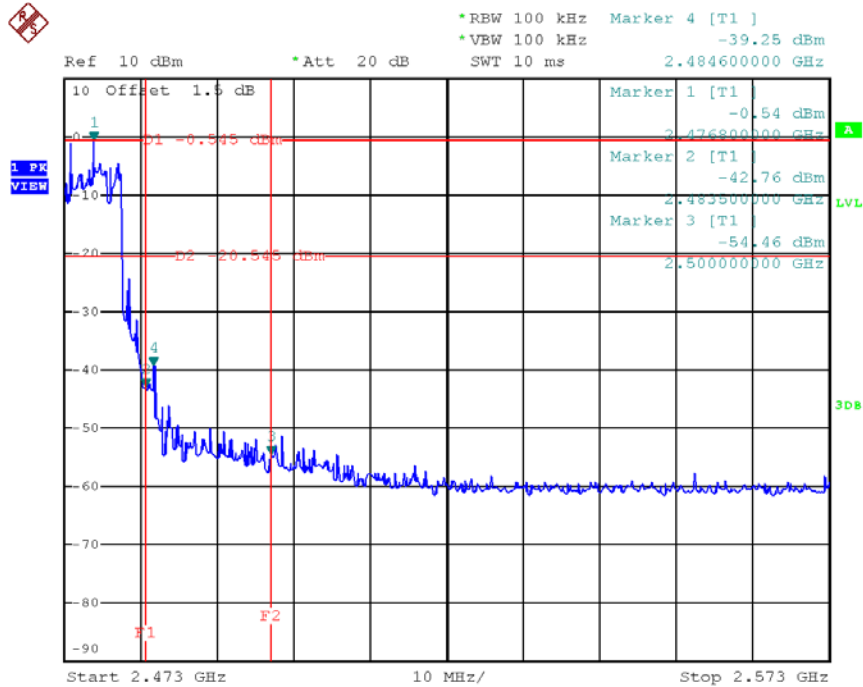

Date: 8.NOV.2017 11:22:30

CH00 (10 Harmonic of the frequency) _3Mbps

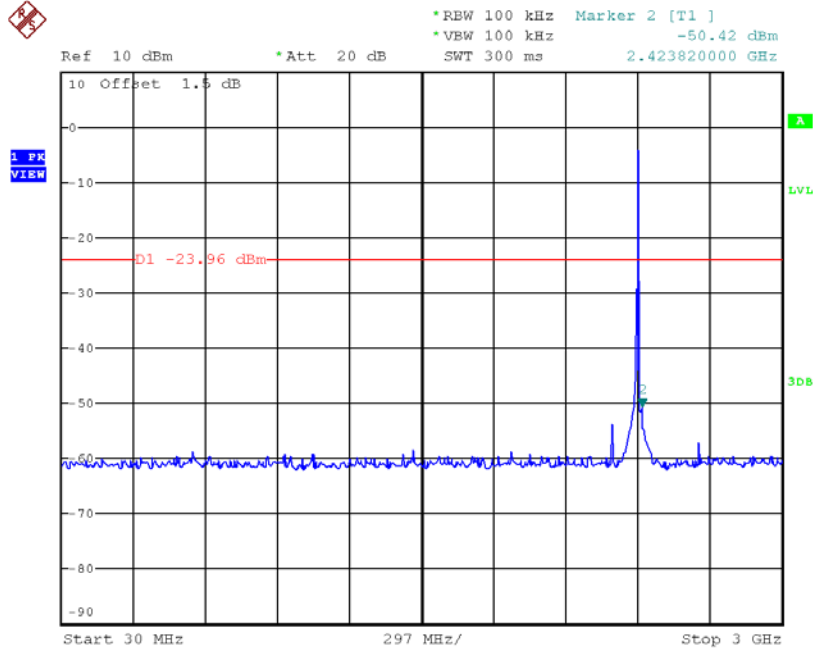

Date: 8.NOV.2017 11:09:49

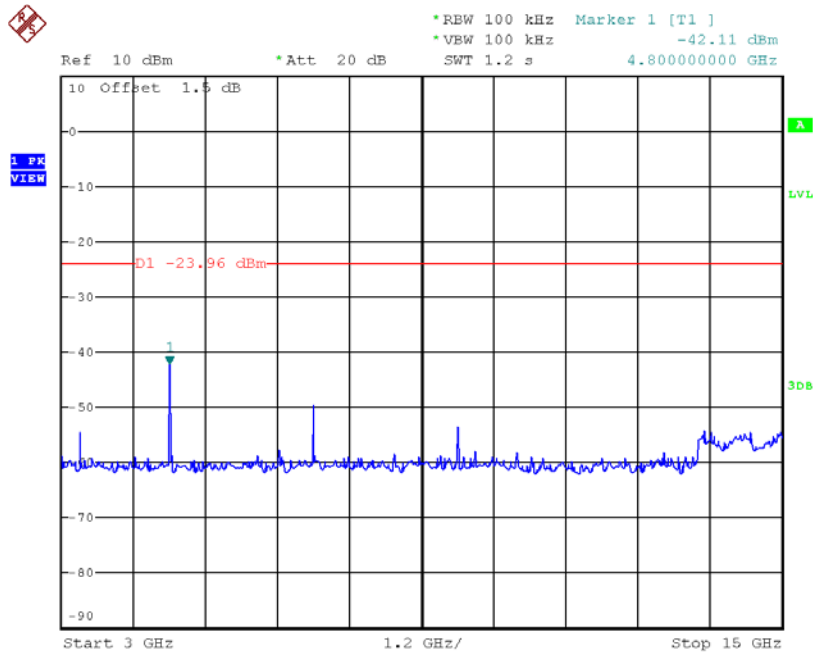

Date: 8.NOV.2017 11:09:56

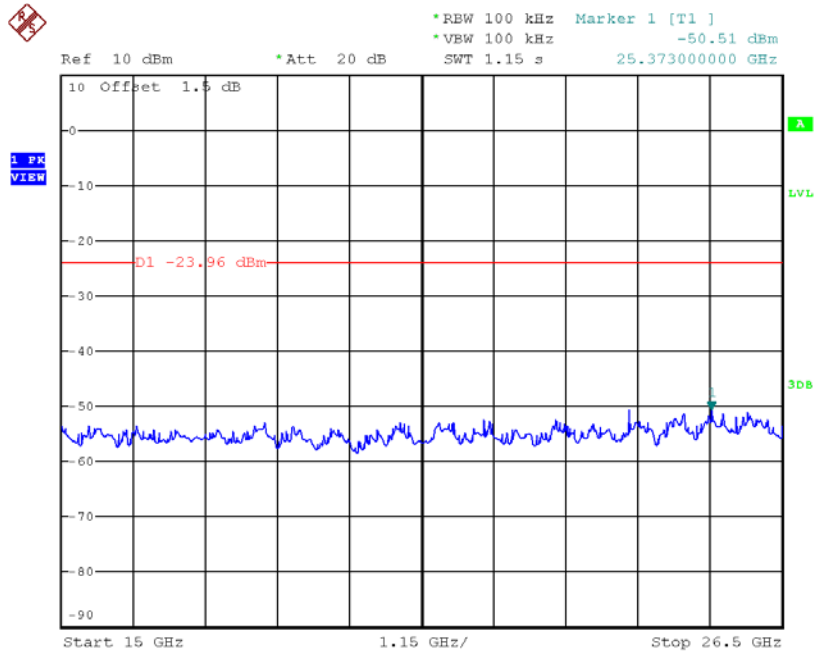

Date: 8.NOV.2017 11:10:03

CH39 (10 Harmonic of the frequency) _3Mbps

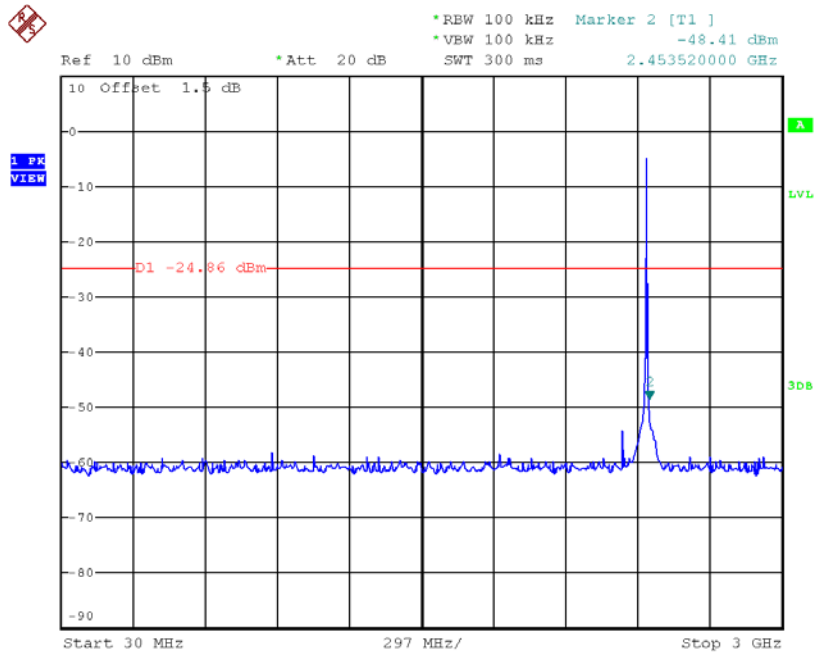

Date: 8.NOV.2017 11:10:37

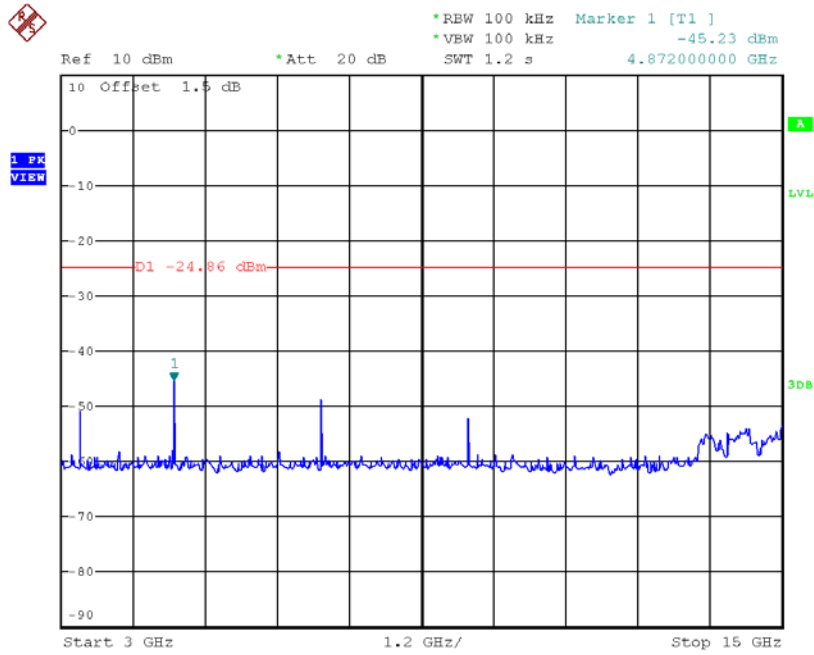

Date: 8.NOV.2017 11:10:44

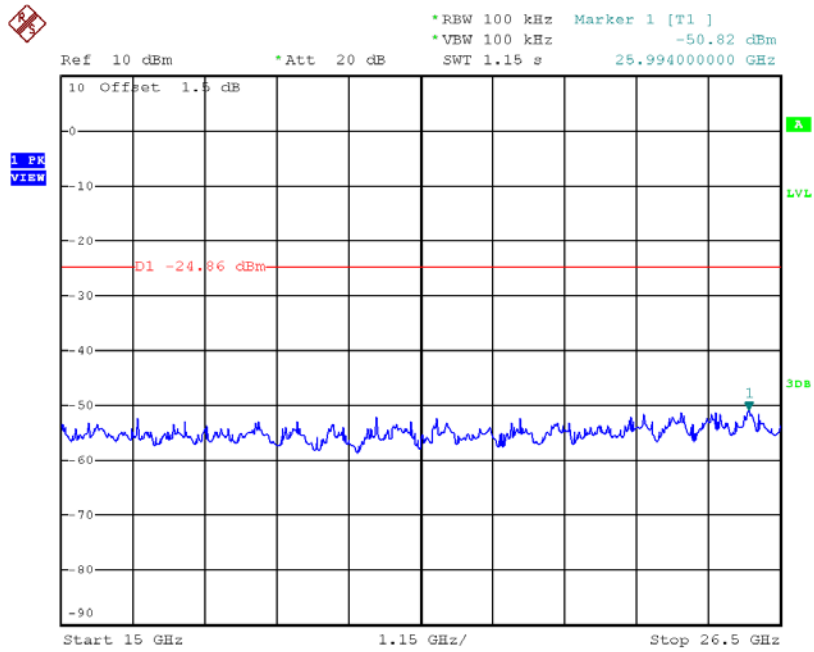

Date: 8.NOV.2017 11:10:52

CH78 (10 Harmonic of the frequency) _3Mbps

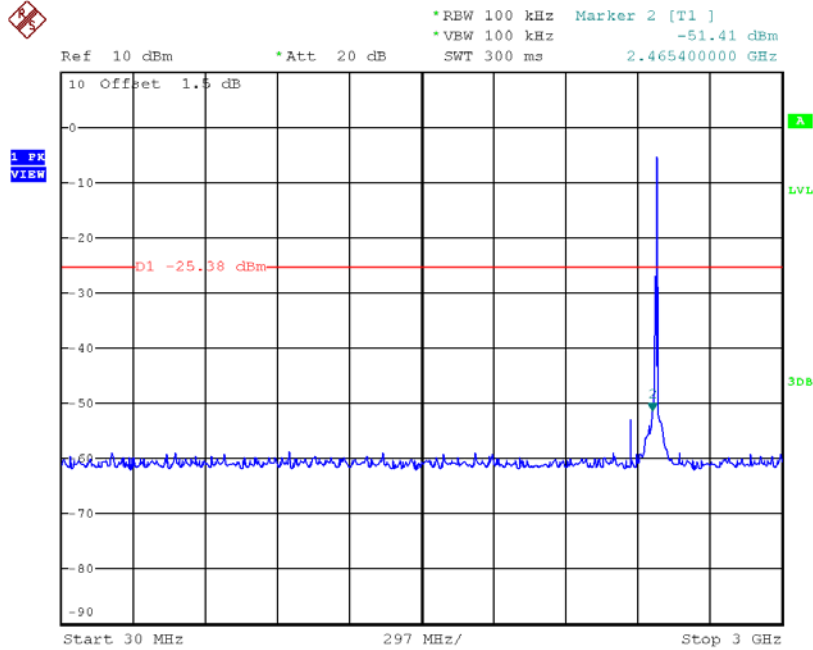

Date: 8.NOV.2017 11:11:59

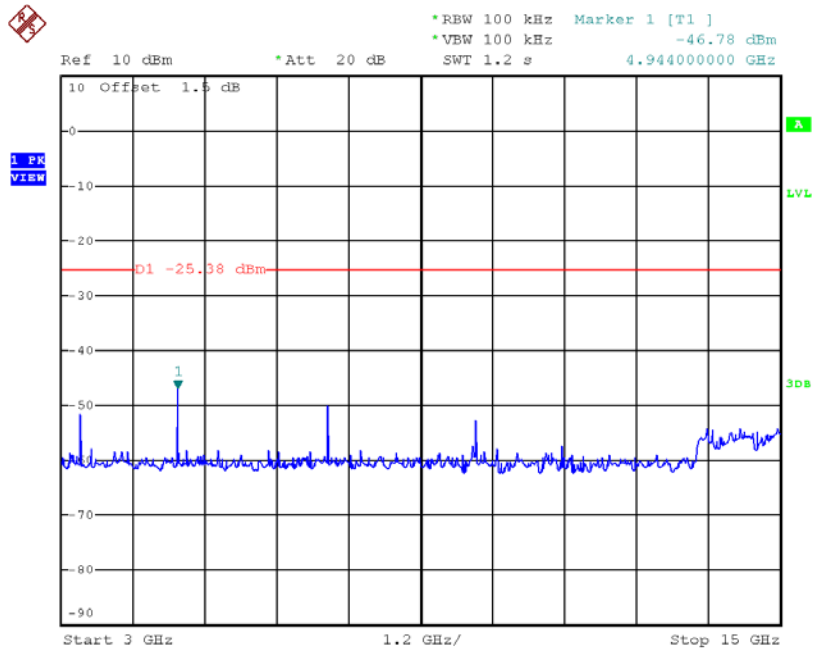

Date: 8.NOV.2017 11:12:06

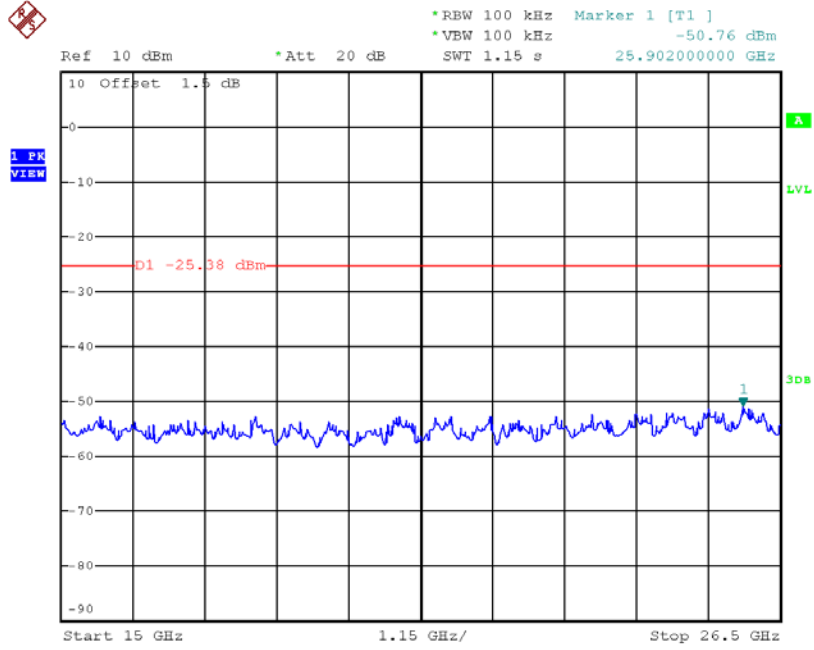

Date: 8.NOV.2017 11:12:13