

Technical Description

The brief circuit description is listed as below:

Main Board Circuit

- 1) U1 acts as MCU (HI3518E).
- 2) Y1 is 24MHz crystal oscillator providing clock for U1.
- 3) U4, U5, U8, U13 act as voltage regulator (SY8088AAC).
- 4) U11 acts as audio amplifier (SC8002B).
- 5) U12 acts as flash memory (MX12L12835FM2I-10G).
- 6) U18 acts as motor MCU (STC15W404AS).
- 7) U2 acts as motor driver (ULN2803).

Sensor Board Circuit

- 1) U4 acts as HD image sensor (OV9732).
- 2) U8, U3, U5 act as voltage regulator (BL9198-3.3V, BL919818AAPRN, XC7206P3V3MR).

WiFi Module Circuit

- 1) U4 acts as WiFi module circuit (MT7601).
- 2) U5 is 40MHz crystal oscillator providing clock for U4.

Antenna Type: Internal antenna

Antenna Gain: 1.0dBi

Operating Mode	Nominal Conducted Power (dBm)
802.11b	21.4
802.11g	24.0
802.11n(HT20)	23.5
802.11n(HT40)	15.7

Peak conducted output power ranges from +15dBm to +24dBm.

The RF transceiver block is a highly integrated WiFi single chip which supports 150Mbps PHY rate. It meets FCC CE certification and IEEE802.11b/g/n standards, offering feature-rich wireless connectivity at high standards, and delivering reliable, cost-effective throughput from an extended distance. Optimized RF architecture and baseband algorithms provide superb performance and lower power consumption. Intekelligent MAC design deploys high efficient DMA engine and hardware data processing accelerators which offloads the host processor. The RF transceiver block is designed to support standard based features in the areas of security quality of service and international regulations, giving end users the greatest performance anytime and in any circumstance.

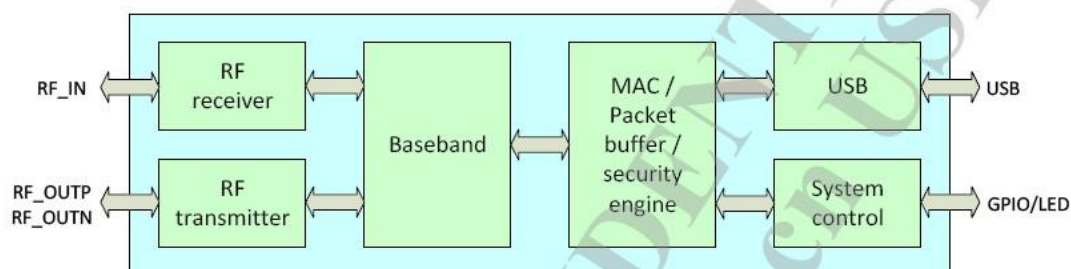

Figure 1 MT7601 block diagram

Electrical and Performance Specification

Item	Description
Product Name	BL-R7601MU2
Major Chipset	MT7601
Host Interface	USB2.0
Standard	IEEE 802.11b, IEEE 802.11g, IEEE 802.11n
Frequency Range	2.4GHz~2.4835GHz
Modulation Type	802.11b: CCK, DQPSK, DBPSK 802.11g: 64-QAM, 16-QAM, QPSK, BPSK 802.11n: 64-QAM, 16-QAM, QPSK, BPSK
Working Mode	Infrastructure, Ad-Hoc
Data Transfer Rate	802.11b: 11, 5.5, 2, 1 Mbps 802.11g: 54, 48, 36, 24, 18, 12, 9, 6 Mbps 802.11n: 150Mbps(MAX)
Spread Spectrum	IEEE 802.11b: DSSS (Direct Sequence Spread Spectrum) IEEE 802.11g/n: OFDM (Orthogonal Frequency Division Multiplexing)
Antenna type	Wire Antenna 1.0dBi Gain



Happiness • Sharing • Technology

BL-R7601MU2

Product Specification

IEEE 802.11b/g/n (1T1R) WLAN USB Module

Version: 3.1

Customer			
Date			
Model Name	BL-R7601MU2		
Part NO.			
Blink Approve Field			
ENGINEER	QC	SALES	
Customer Approve Field			
ENGINEER	QC	MANUFACTORY	PURCHASING

联系电话: 0086-13798358430

联络人: 夏先生

传真: 0755-28029002

邮箱: Xia@b-link.net.cn

网址: www.b-link.net.cn

公司地址: 深圳市宝安区观澜街道福前路268号必联工业园

Content

Content	1
1. General Description.....	2
2. The range of applying	2
3. Product Specification.....	2
3.1 Function Block diagram	2
3.2 Electrical and Performance Specification.....	3
3.3 DC Characteristic	3
3.4 RF Characteristic.....	4
3.4 Product Photo.....	5
3.5 Mechanical Specification	5
3.6 Product Pin Definition	6
4. Supported platform.....	6
5. WiFi RF Circuit reference pictures	6
6. Package Information	7
7. Typical Solder Reflow Profile	7
8. Precautions for use	7

1. General Description

BL-R7601MU2 product accord with FCC CE is a highly integrated Wi-Fi single chip which support 150 Mbps PHY rate. It fully complies with IEEE802.11n and IEEE802.11b/g standard, offering feature-rich wireless connectivity at high standard, and delivering reliable, cost-effective throughput from an extended distance. Optimized RF architecture and baseband algorithms provide superb performance and lower power consumption. Intelligent MAC design deploys a high efficient DMA engine and hardware data processing accelerators which offloads the host processor.

2. The range of applying

MID, networking camera, STB GPS, E-book, Hard disk player, Network Radios, PSP and other device which need be supported by wireless networking.

3. Product Specification

3.1 Function Block diagram

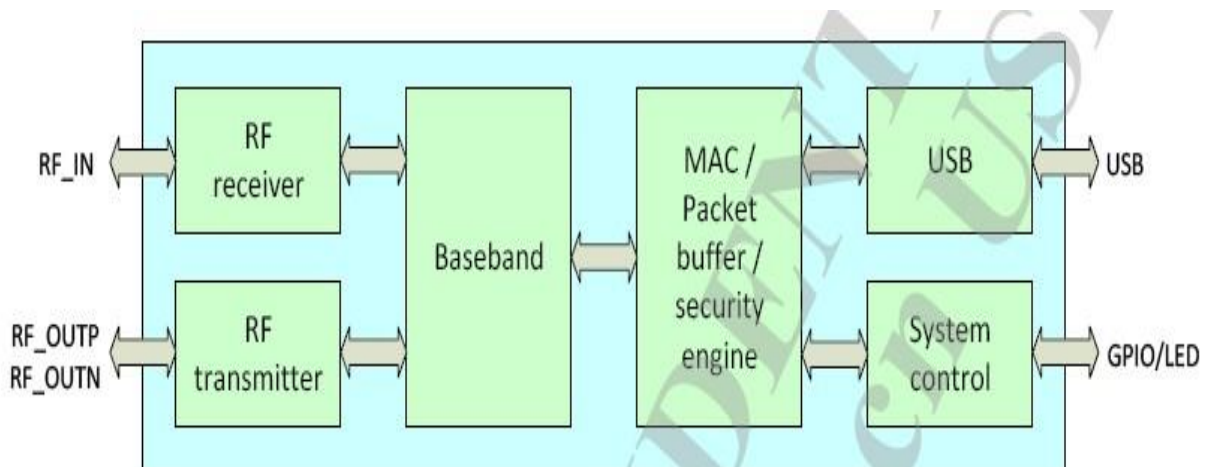

Figure 1 MT7601 block diagram

3.2 Electrical and Performance Specification

Item	Description
Product Name	BL-R7601MU2
Major Chipset	MT7601
Host Interface	USB2.0
Standard	IEEE 802.11b, IEEE 802.11g, IEEE 802.11n
Frequency Range	2.4GHz~2.4835GHz
Modulation Type	802.11b: CCK, DQPSK, DBPSK 802.11g: 64-QAM, 16-QAM, QPSK, BPSK 802.11n: 64-QAM, 16-QAM, QPSK, BPSK
Working Mode	Infrastructure, Ad-Hoc
Data Transfer Rate	802.11b: 11, 5.5, 2, 1 Mbps 802.11g: 54, 48, 36, 24, 18, 12, 9, 6 Mbps 802.11n: 150Mbps(MAX)
Spread Spectrum	IEEE 802.11b: DSSS (Direct Sequence Spread Spectrum) IEEE 802.11g/n: OFDM (Orthogonal Frequency Division Multiplexing)
Sensitivity @PER	135M: -68dBm@10%PER 54M: -74dBm@10%PER 11M: -86dBm@8%PER 6M: -90dBm@10%PER 1M: -92dBm@8%PER
RF Power(Typical)	135M: 14dBm, 54M: 15dBm, 11M: 17dBm
Antenna type	Connect to the external antenna through the half hole
The transmit distance	Indoor 100M, Outdoor 300M, according the local environment
Dimension(L*W*H)	13.0*12.3*1.6mm (LxWxH) , Tolerance: +/-0.15mm
Power supply	3.3V +/-0.15V
Power Consumption	standby mode 50mA@3.3V , TX mode 245mA@3.3V
Clock source	40MHz
Working Temperature	0°C to +50°C
Storage temperature	-40°C to +85°C

3.3 DC Characteristic

Terms	Contents
Specification : IEEE802.11b	
Mode	DSSS / CCK
Frequency	2412 – 2484MHz
Data rate	1, 2, 5.5, 11Mbps

DC Characteristics	min	Typ.	max.	unit
TX mode	239	245	249	mA
Rx mode	91	92	93	mA
Sleep mode	47	48	48	mA
Specification : IEEE802.11g				
Mode	OFDM			
Frequency	2412 - 2484MHz			
Data rate	6, 9, 12, 18, 24, 36, 48, 54Mbps			
DC Characteristics	min	Typ.	max.	unit
TX mode	149	150	153	mA
Rx mode	92	93	100	mA
Sleep mode	46	48	49	mA
Specification : IEEE802.11n				
Mode	OFDM			
Frequency	2412 - 2484MHz			
Data rate	6.5, 13, 19.5, 26, 39, 52, 58.5, 65Mbps			
DC Characteristics	min	Typ.	max.	unit
TX mode	151	152	153	mA
Rx mode	91	92	93	mA
Sleep mode	47	48	49	mA

3.4 RF Characteristic

Mode	Rate(Mbps)	Power(dBm)			EVM(dB)			Sensitivity(dBm)		
		CH1	CH7	CH13	CH1	CH7	CH13	CH1	CH7	CH13
11b	1	17.43	17.79	17.48	-31.18	-32.78	-31.52	-95	-95	-95
	11	17.50	17.26	17.91	-32.87	-33.15	-33.41	-89	-89	-89
11g	6	17.58	17.28	17.49	-34.21	-33.18	-33.87	-90	-90	-90
	54	16.70	16.57	16.33	-30.42	-31.25	-31.02	-74	-74	-74
11n	MCS0	17.32	17.24	17.48	-28.97	-29.18	-29.65	-88	-88	-88
HT20	MCS7	16.86	16.40	16.12	-30.67	-30.98	-31.70	-70	-70	-70
11n	MCS0	17.54	17.84	17.26	-30.54	-30.21	-30.47	-89	-89	-89
HT40	MCS7	16.38	16.06	16.12	-31.41	-31.28	-31.07	-69	-69	-69

3.4 Product Photo

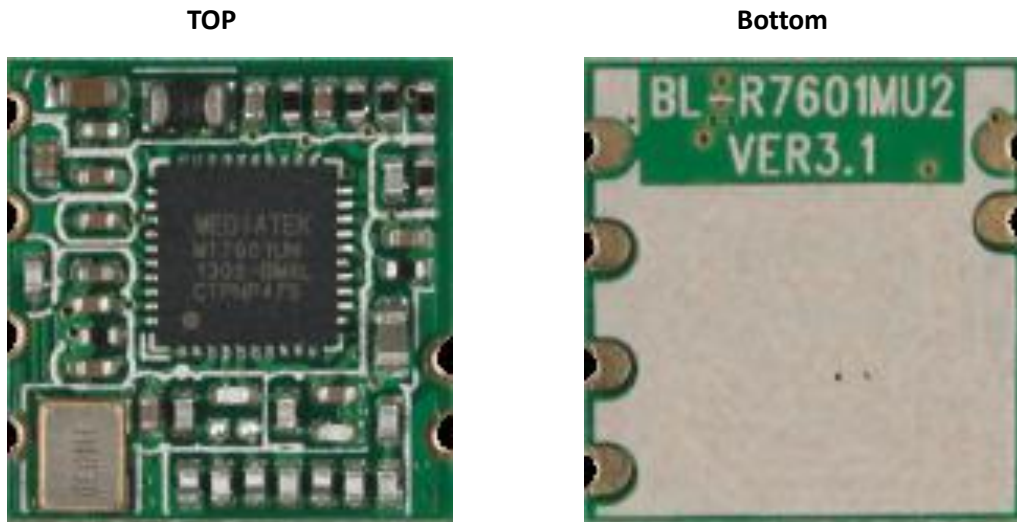

3.5 Mechanical Specification

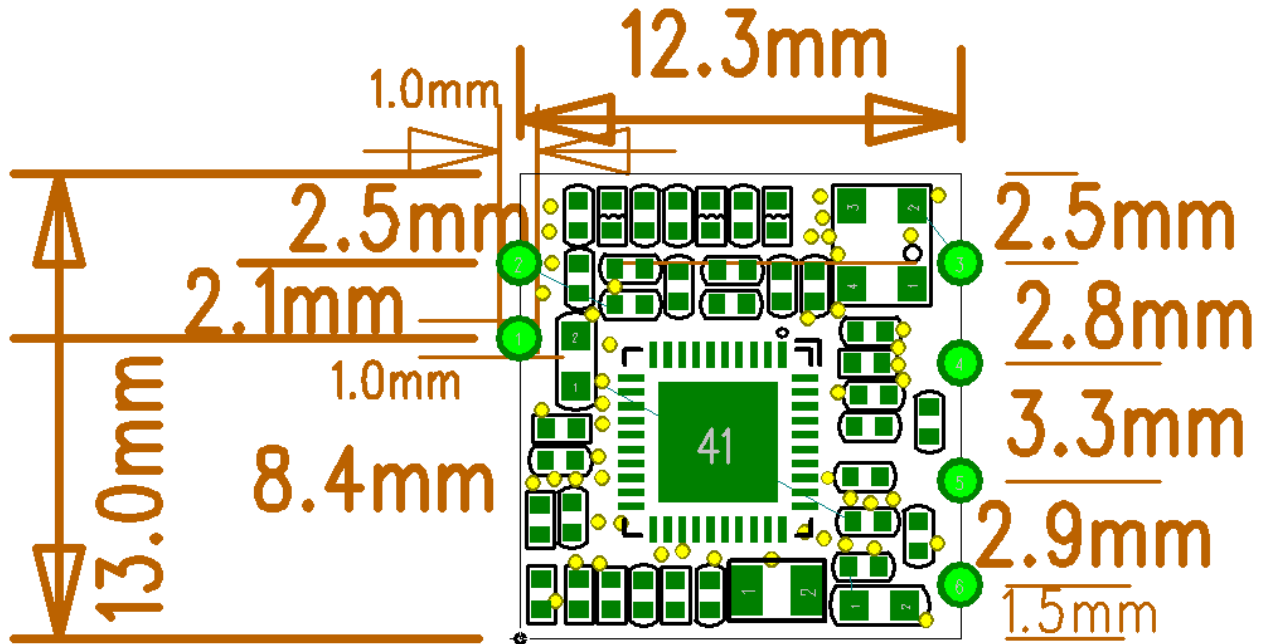

3.6 Product Pin Definition

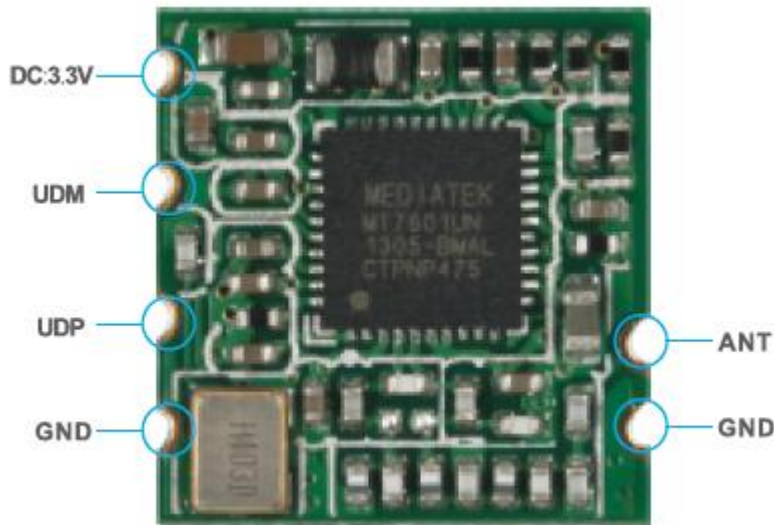

4. Supported platform

Operating System	CPU Framework	Driver
WIN2000/XP/VISTA/WIN7	X86 Platform	Enable
LINUX2.4/2.6	ARM, MIPSII	Enable
WINCE5.0/6.0	ARM ,MIPSII	Enable

5. WiFi RF Circuit reference pictures

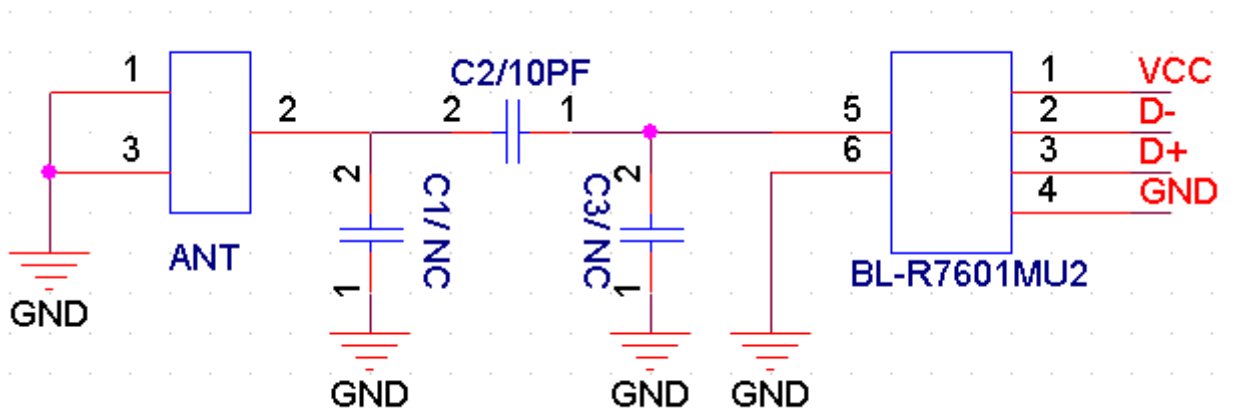

- Note: 1.Pl reserve a “pi” circuit for antenna matching.
 2. The RF circuit needs to keep 50 Ω impedance.
 3. The USB differential pair needs to keep 90 Ω impedance.

6. Package Information



BL-R7601MU2



Tape and reel packaging method,
each disk 2000PCS



7. Typical Solder Reflow Profile

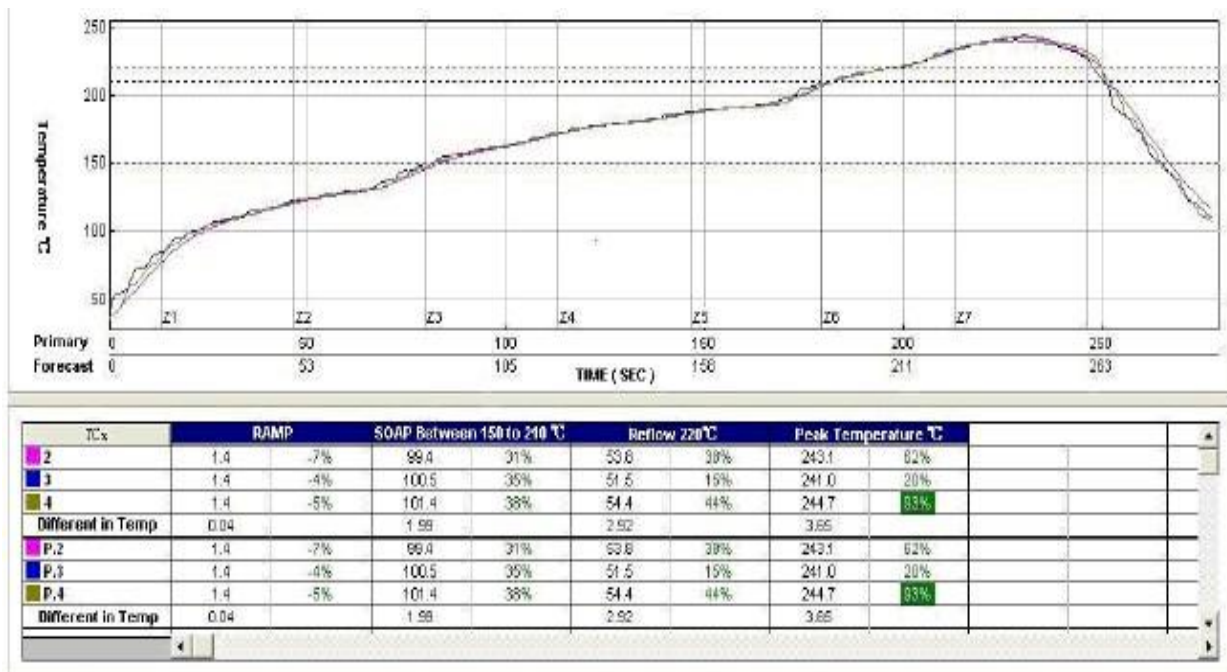

8. Precautions for use

1. Pls handle the module under ESD protection.
2. Reflow soldering shall be done according to the solder reflow profile. Peak temperature 245°C.
3. Products require baking before mounting if humidity indicator cards reads >30% temp <30 degree C, humidity < 70% RH, over 96 hours.
Baking condition: 125 degree C, 12 hours
Baking times: 1 time
4. Storage Condition: Moisture barrier bag must be stored under 30 degree C, humidity under 85% RH. The calculated shelf life for the dry packed product shall be a 12 months from the bag seal date. Humidity indicator cards must be blue, <30%.