

## Technical Description

The Equipment Under Test (EUT) is a Bluetooth Wireless Speaker which equips a 2.4GHz Frequency Hopping Spread Spectrum Transceiver (Bluetooth 2.1). It operates at frequency range of 2402MHz to 2480MHz. There are total 79 channels with 1MHz channel spacing. The EUT can accept analog audio (AUX-in) and wireless audio when paired with a Bluetooth devices. The audio signal is amplified and driving internal loudspeaker. The EUT is powered by a 3.7V internal rechargeable battery. The internal battery can be charged via USB port. USB charging cable is supplied in the final product for end-user. But no AC/DC adaptor will be included in the product package.

Model: AWSHRTST may come in color variations but are electrically and mechanically the same. The only difference is the color.

The antenna used in the EUT is internal, integral.

### **2.4GHz Bluetooth Module:**

**Modulation Type: GFSK**

**Antenna Type: Integral, Internal (PCB Trace)**

**Frequency Range: 2402MHz - 2480MHz, 1MHz channel spacing, 79 channels**

**Nominal field strength is 97.8 dB $\mu$ V/m**

**Production Tolerance of field strength is +/- 3dB**

**Antenna gain is 0dBi**

**The functions of main ICs are mentioned below.**

### **1. Bluetooth module F-6008 (U6):**

- 1) BK8008 (U5) acts as the 2.4GHz radio core of Bluetooth module F-6008 (U6) which is integrating with audio CODEC.
- 2) The 26MHz crystal (X1) provides system clock for BK8008 (U5).
- 3) 25F04 is 4kbit serial flash EEPROM for parameter storage.
- 4) C9 and C10 act as antenna matching network.

### **2. MCU Portion:**

- 1) U3 (FM8PE53) acts as OTP MCU.

### **3. Charger portion:**

- 1) U4 (LY4507) acts as battery charger.

### **4. Audio portion:**

- 1) U1 (FT2920) is power amplifier driving internal loudspeaker.

### Bluetooth 2.1

CH. NO.	FRE.	Hex Value		CH. NO.	FRE.	Hex Value		CH. NO	FRE.	Hex Value		CH. NO	FRE.	Hex Value
CH0	2402MHz	0		CH26	2428MHz	1A		CH52	2454MHz	34		CH78	2480MHz	4E
CH1	2403MHz	1		CH27	2429MHz	1B		CH53	2455MHz	35				
CH2	2404MHz	2		CH28	2430MHz	1C		CH54	2456MHz	36				
CH3	2405MHz	3		CH29	2431MHz	1D		CH55	2457MHz	37				
CH4	2406MHz	4		CH30	2432MHz	1E		CH56	2458MHz	38				
CH5	2407MHz	5		CH31	2433MHz	1F		CH57	2459MHz	39				
CH6	2408MHz	6		CH32	2434MHz	20		CH58	2460MHz	3A				
CH7	2409MHz	7		CH33	2435MHz	21		CH59	2461MHz	3B				
CH8	2410MHz	8		CH34	2436MHz	22		CH60	2462MHz	3C				
CH9	2411MHz	9		CH35	2437MHz	23		CH61	2463MHz	3D				
CH10	2412MHz	A		CH36	2438MHz	24		CH62	2464MHz	3E				
CH11	2413MHz	B		CH37	2439MHz	25		CH63	2465MHz	3F				
CH12	2414MHz	C		CH38	2440MHz	26		CH64	2466MHz	40				
CH13	2415MHz	D		CH39	2441MHz	27		CH65	2467MHz	41				
CH14	2416MHz	E		CH40	2442MHz	28		CH66	2468MHz	42				
CH15	2417MHz	F		CH41	2443MHz	29		CH67	2469MHz	43				
CH16	2418MHz	10		CH42	2444MHz	2A		CH68	2470MHz	44				
CH17	2419MHz	11		CH43	2445MHz	2B		CH69	2471MHz	45				
CH18	2420MHz	12		CH44	2446MHz	2C		CH70	2472MHz	46				
CH19	2421MHz	13		CH45	2447MHz	2D		CH71	2473MHz	47				
CH20	2422MHz	14		CH46	2448MHz	2E		CH72	2474MHz	48				
CH21	2423MHz	15		CH47	2449MHz	2F		CH73	2475MHz	49				
CH22	2424MHz	16		CH48	2450MHz	30		CH74	2476MHz	4A				
CH23	2425MHz	17		CH49	2451MHz	31		CH75	2477MHz	4B				
CH24	2426MHz	18		CH50	2452MHz	32		CH76	2478MHz	4C				
CH25	2427MHz	19		CH51	2453MHz	33		CH77	2479MHz	4D				



F-6008  
DID:D026979

---

## 一、 INTRODUCTION:

F-6008 is the Bluetooth 2.1+EDR module for intelligent wireless audio transmission products designed by our company and qualified by SIG with QDID: 61231. F-6008 also is the low cost stereo audio Bluetooth solution with high performance. The main chip uses BK8008 chip, providing the high quality and best compatibility. Without any driver, you can connect the module with your device to enjoy the high quality music easily. Support two same speaker.

## 二、 APPLICATIONS:

F-6008 is used for Bluetooth audio transmission and it is convenience to connect with mobile phone , personal computer , PDA and other digital products with Bluetooth hardware to enjoy the music wirelessly .The major application are included :

- ◇ Bluetooth speaker
- ◇ Bluetooth stereo headset
- ◇ Hands-free phone
- ◇ Bluetooth speaker with data transmission

## 三、 FEATURES:

Bluetooth Profiles

0 Bluetooth V2.1+EDR specification support

0 A2DPv1.2

0 AVRCPv1.4

0 HFPv1.5

※

GAVDP1.2

※HSP1.2

※IOP

## 四、 PARAMETERS :

Module	F-6008
BLUETOOTH	Bluetooth V2.1+EDR
SUPPLY VOLTAGE:	DC2.8-4.2V
SUPPORT BLUETOOTH Profile	HFPV1.5, A2DPV1.2, AVRCPV1.4, HSP1.2, GAVDP1.2, IOP
Working CURRENT	<b>≤45mA</b>
STANDBY CURRENT	<500uA
TEMPERATURE RANGE	-40°C to +85°C
THE WIRELESS TRANSMISSION RANGE:	> 10 m
TRANSMISSION POWER:	CLASS2, 4dbm
SENSITIVITY:	-80dBm<0.1%BER
FREQUENCY RANGE:	2.4GHz-2.480GHz
Interface:	I2C, SPI and UART interface
AUDIO PERFORMANCE	SBC algorithm
THE AUDIO SNR:	≥75dB
MODULE SIZE	25X13.5X1.8MM



五、 OUTLINE DIMENSION (MODULE FOOT PRINT):

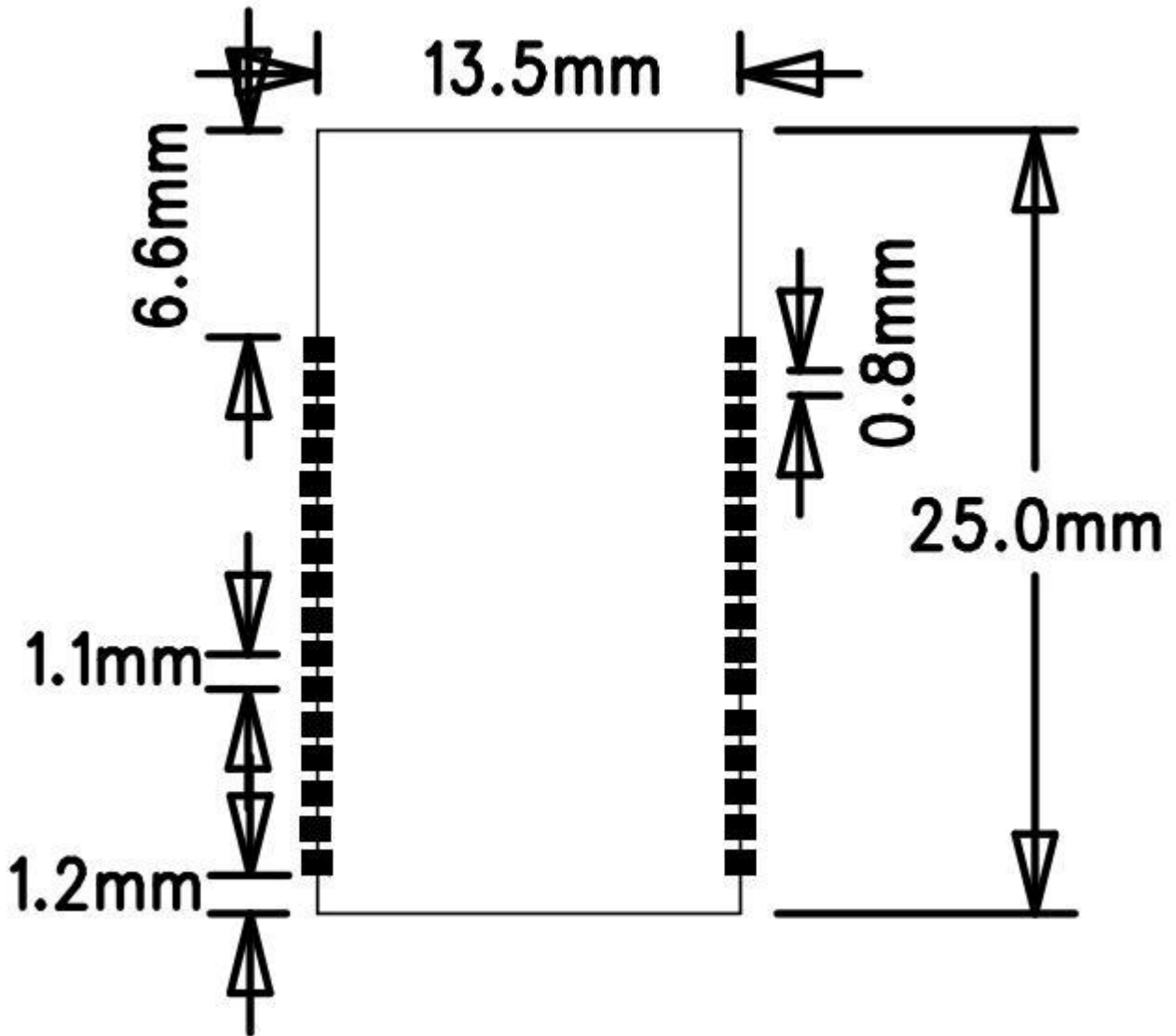



## 六 DEVICE PINOUT DIAGRAM

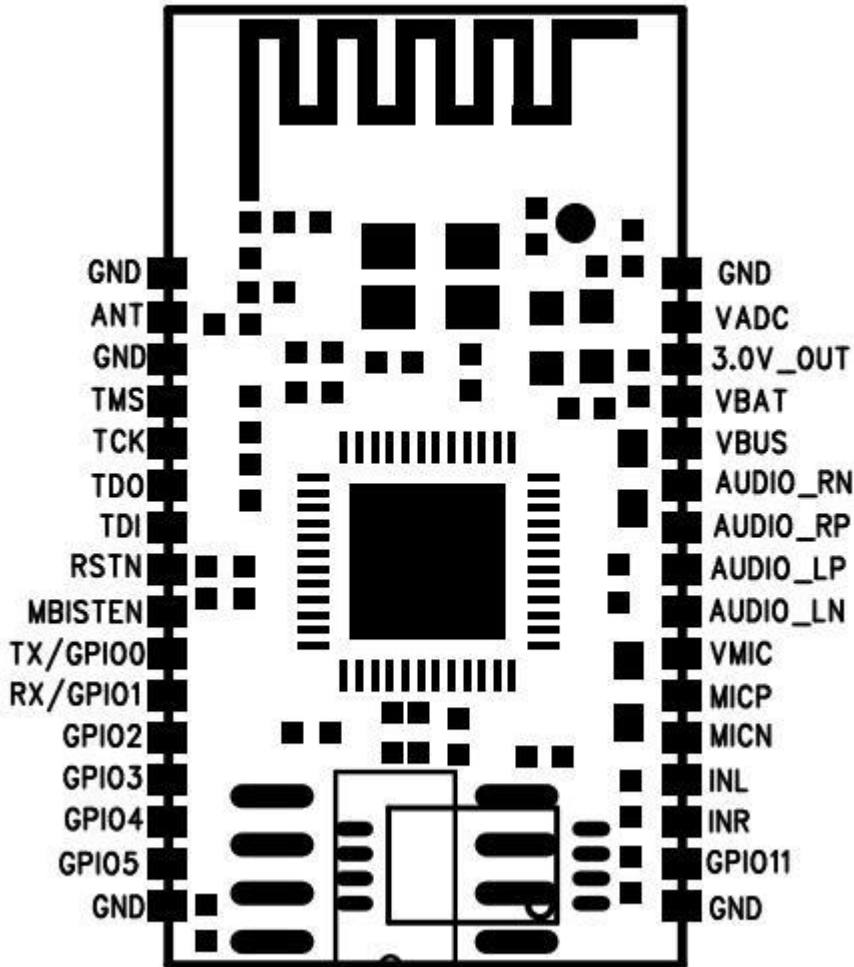

## 七、PIN DEFINITION

Pin	Symb	I/O	Description
1	GND	GND	RF_GND
2	ANT	ANT	ANT PORT
3	GND	GND	RF_GND
4	TMS(GPIO19)	Digital I/O	JTAG pin
5	TCK(GPIO18)	Digital I/O	JTAG pin
6	TDO(GPIO21)	Digital I/O	JTAG pin
7	TDI(GPIO20)	Digital I/O	JTAG pin
8	RSTN	Digital I/O	JTAG pin / Reset pin-low active
9	MBISTEN	Digital I/O	Memory bit check
10	GPIO0(TX)	Digital I/O	UART TX
11	GPIO1(RX)	Digital I/O	UART RX
12	GPIO2	Digital I/O	GPIO2
13	GPIO3	Digital I/O	GPIO3
14	GPIO4	Digital I/O	GPIO4
15	GPIO5	Digital I/O	GPIO5
16	GND	GND	Ground connect battery negative
17	AGND	AGND	Ground connect battery negative
18	GPIO11	Digital I/O	GPIO11
19	LINR	AUX_INPUT	LINR
20	LINL	AUX_INPUT	LINL
21	MICN	MIC-	MICN
22	MICP	MIC+	MICP
23	VMIC	VMIC	VMIC
24	AUDIOLN	Audio output	Left channel audio output negative
25	AUDIOLP	Audio output	Left channel audio output positive
26	AUDIORP	Audio output	Right channel audio output positive
27	AUDIORN	Audio output	Right channel audio output negative
28	VBUS	Charge port	VBUS
29	VBAT	Power supply	Power supply
30	3V0	Power	3.0V output
31	ADC	Power	ADC input
32	GND	GND	GND



## 八 NOTICE:

**F-6008** In order to better SNR, please pay attention to the hardware design of PA, DC booster and the module power circuit to avoid influencing module.

1. A. The signal strength is depending on the environment of Bluetooth application, such as wood and metal will block the transmission signal to get the shorter transmission distance.
2. Because of metal will block the signal transmission, it is recommend not to using the metal housing.
3. PCB layout guideline: no any copper existed in the antenna area of the module.

## 九、 APPLICATION CIRCUIT:

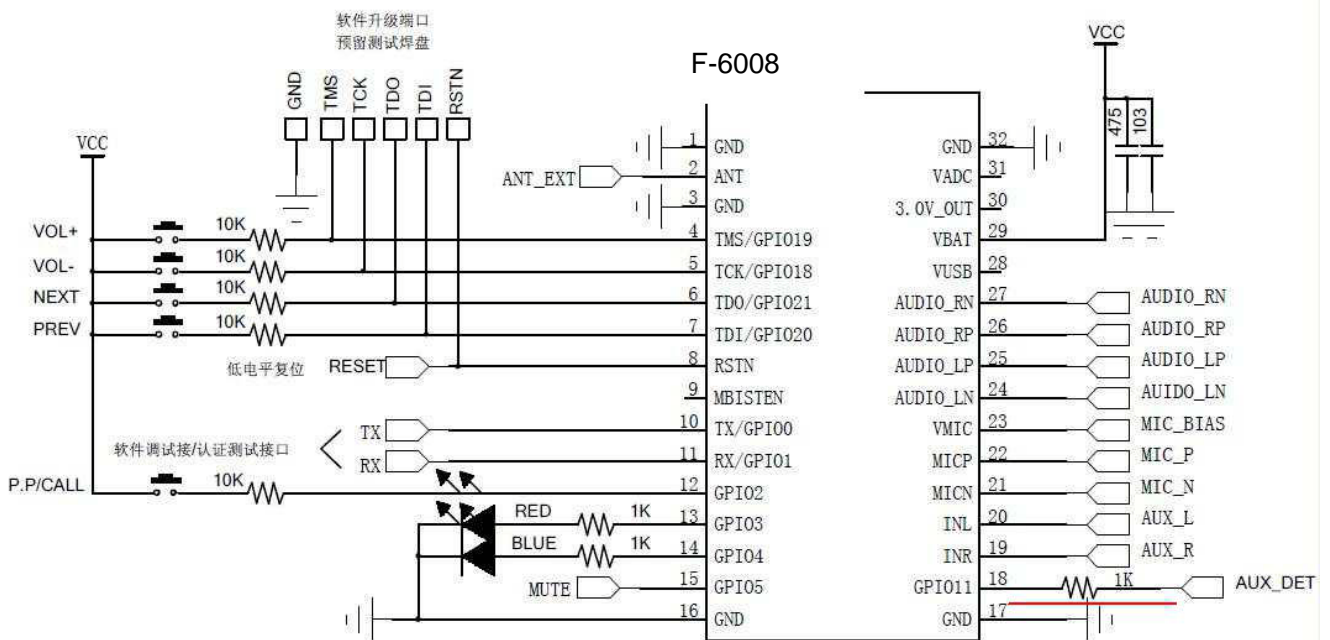

## NOTICES:

The module has built-in antenna, no need external antenna except the application needed

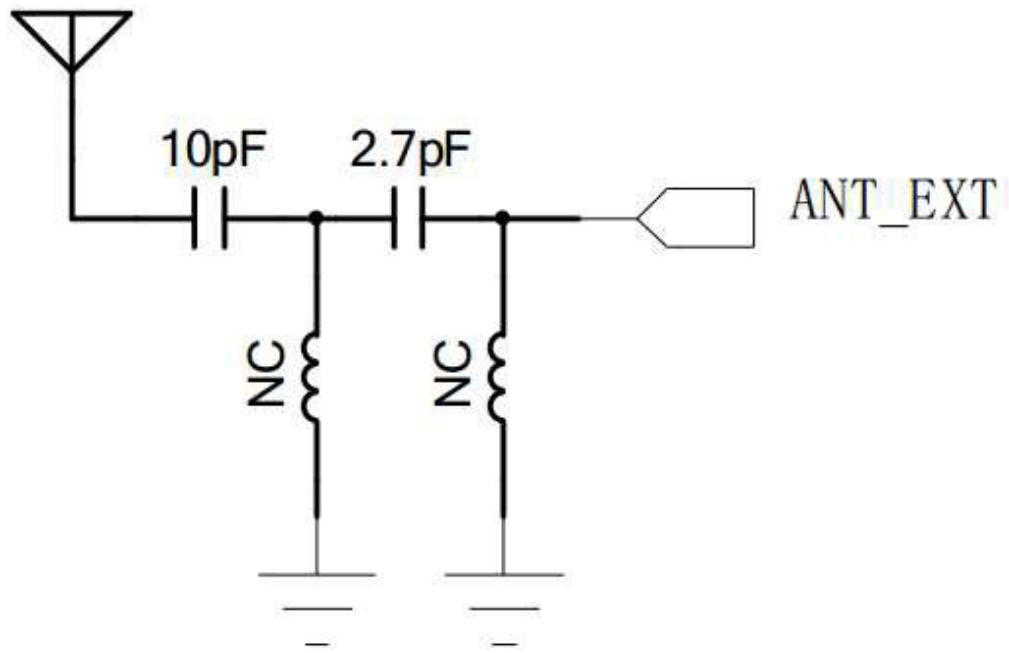

MIC Recommended Specification: Sensitivity-38DB +/-2DB, Working voltage: DC2V

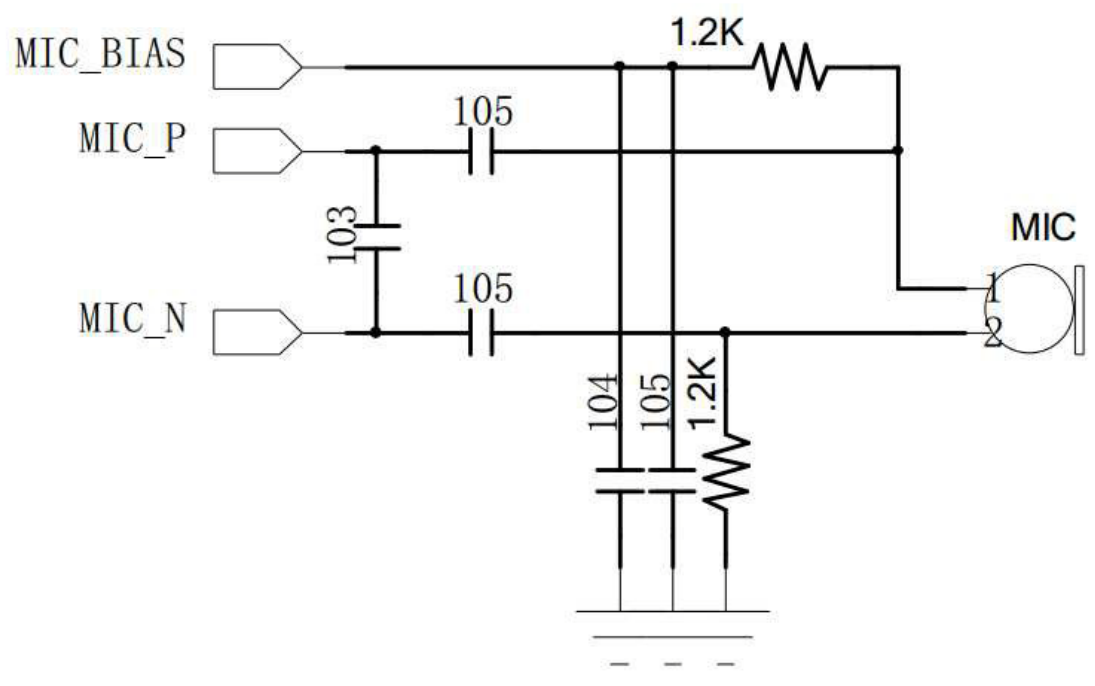



## + THE REFLOW TEMPERATURE

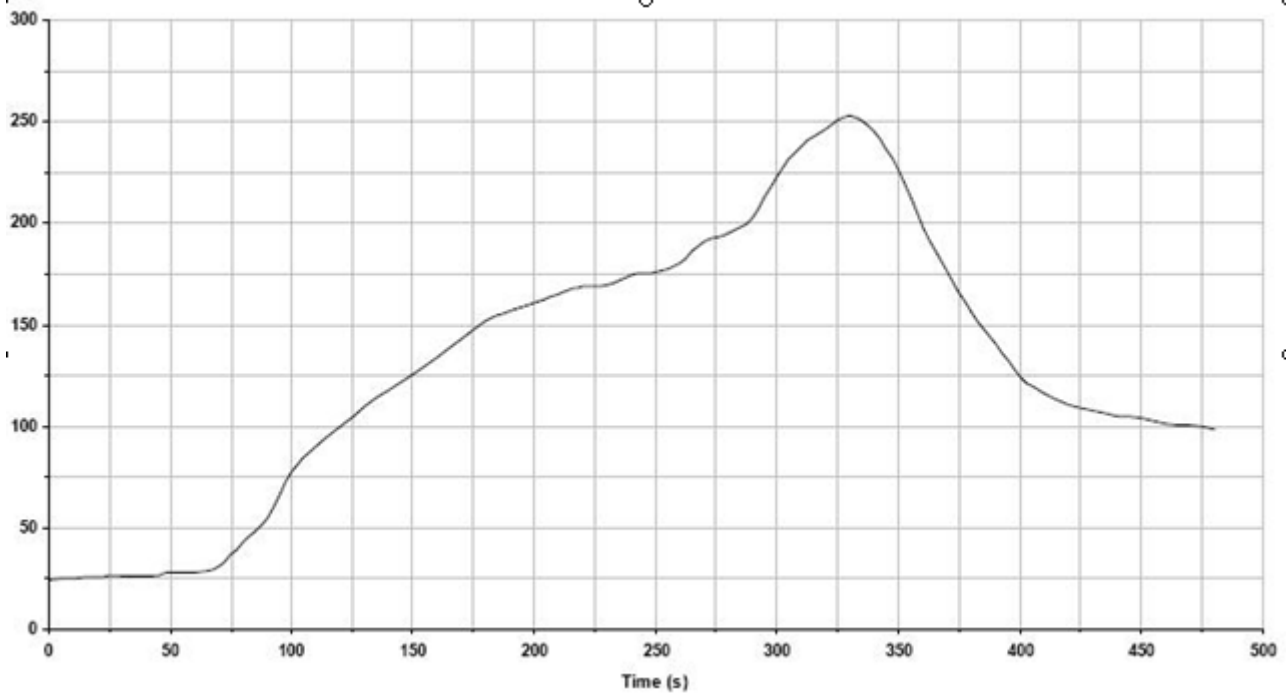

Key features of the profile:

- Initial Ramp=1-2.5°C/sec to 175°C equilibrium
- Equilibrium time=60 to 80 seconds
- Ramp to Maximum temperature (250°C)=3°C/sec Max
- Time above liquidus temperature(217°C): 45 - 90 seconds
- Device absolute maximum Reflow temperature: 250°C



---

# BK8008 Bluetooth Audio SoC Datasheet

---

## *Preliminary Specification*

### Approvals

<i>Name</i>	<i>Date</i>	<i>Signature</i>

Beken Corporation  
3A, 1278 Keyuan Rd, Shanghai 201204, China  
PHONE: (86)21 5108 6811  
FAX: (86)21 6087 1277

*This document contains information that may be proprietary to, and/or secrets of, Beken Corporation. The contents of this document should not be disclosed outside the companies without specific written permission.*

*Disclaimer: Descriptions of specific implementations are for illustrative purpose only, actual hardware implementation may differ.*



## ***Revision History***

<b>Rev.</b>	<b>Date</b>	<b>Author(s)</b>	<b>Remark</b>
0.1	10/May/2014	Weifeng	Initial Draft
0.2	5/June/2014	Weifeng	Add 7x7 56-pin package to support SD-card
	16/July/2014	Weifeng	Release the word file to XZX



**Contents**

- 1. General Description ..... 4
  - 1.1. Features ..... 4
  - 1.2. Applications ..... 4
- 2. Pin Definition..... 5
- 3. Functional Description..... 7
  - 3.1. GPIO ..... 7
  - 3.2. PWM Timer and Watch Dog Timer..... 8
  - 3.3. Power Management..... 8
  - 3.4. MCU ..... 8
  - 3.5. I2C and UART Interface..... 8
  - 3.6. FM Receiver Control Interface ..... 8
  - 3.7. FLASH Access Interface ..... 9
  - 3.8. SPI..... 9
  - 3.9. SAR ADC and LED ..... 9
  - 3.10. Audio Peripheral ..... 9
- 4. Electrical Characteristics ..... 10
  - 4.1. Absolute Maximum Ratings ..... 10
  - 4.2. Recommended Operating Conditions ..... 10
  - 4.3. System LDO..... 10
  - 4.4. Analog LDO/BUCK ..... 10
  - 4.5. Digital LDO/BUCK ..... 11
  - 4.6. USB LDO..... 11
  - 4.7. Typical Power Consumption..... 11
  - 4.8. RF Characteristics ..... 11
  - 4.9. Audio Characteristics ..... 12
- 5. Application Schematic ..... 12
- 6. About the Qualification ..... 12
- 7. Package Information ..... 13
- 8. Ordering Information..... 14

## 1. General Description

The BK8008 chip is a highly integrated single-chip Bluetooth audio device. It integrates the high-performance transceiver, rich features baseband processor, and Bluetooth audio profile. The BK8008 cache based architecture enables it is fully programmable with any application, that it may be used for control and multimedia hybrid application. The internal dual stereo ADC converts the stereo line in input to digital audio that enables the line in use the digital equalizer. Hardware equalizer and accelerator offload the MCU, and make it suitable for low power headset application.

- Bluetooth 2.1+ EDR compliant
- -92 dBm sensitivity for 2 Mbps mode and 5 dBm transmit power
- A2DP v1.2, AVRCP v1.0 and HFP v1.5 profile
- Integrated 96 dB SNR stereo ADC and stereo DAC
- Five bands hardware equalizer
- Digital equalizer for stereo line in
- Hardware accelerator for low power
- Full duplex hands-free speakerphone
- Up to 250 mA charge controller

## 1.2. Applications

### 1.1. Features

- Operation voltage from 2.8 V to 4.2 V

- Bluetooth stereo speaker
- Bluetooth stereo headset
- Bluetooth control and multimedia hybrid

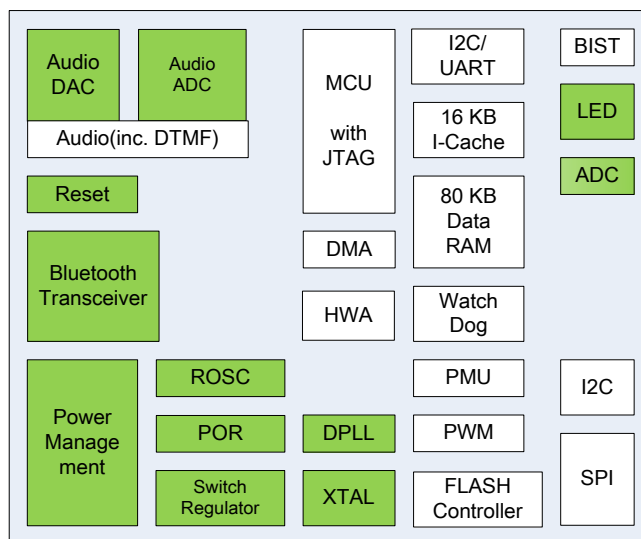

## 2. Pin Definition

It provides maximum QFN6x6 48-pins package for wireless audio application.

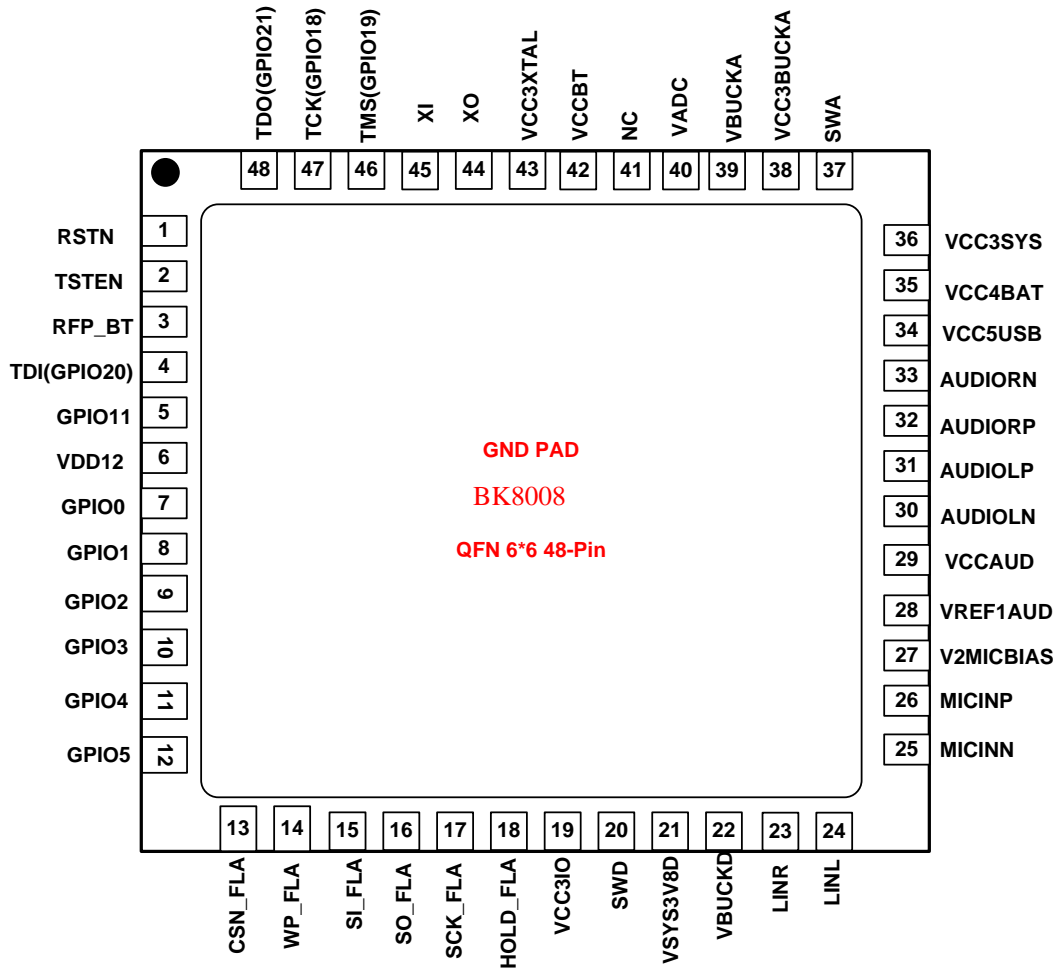

**Table 1 Pin Description of 48Pin Package**

PIN	Name	Pin Function	Description
1	RSTN	Digital I/O	Active low reset
2	TSTEN	Digital I/O	Test enable, high enable chip in test mode
3	RFP_BT	RF port	2.4 GHz antenna port
4	TDI	Digital I/O	JTAG TDI, GPIO20
5	GPIO11	Digital I/O	General I/O
6	VDD12	Power	1.2 V LDO output
7	GPIO0	Digital I/O	GPIO
8	GPIO1	Digital I/O	GPIO
9	GPIO2	Digital I/O	GPIO



10	GPIO3	Digital I/O	GPIO
11	GPIO4	Digital I/O	GPIO
12	GPIO5	Digital I/O	GPIO
13	CSN_FLA	Digital I/O	FLASH CSN
14	WP_FLA	Digital I/O	FLASH WP
15	SI_FLA	Digital I/O	FLASH SI
16	SO_FLA	Digital I/O	FLASH SO
17	SCK_FLA	Digital I/O	FLASH SCK
18	HOLD_FLA	Digital I/O	FLASH HOLD
19	VCC3IO	Power	3.3 V LDO output
20	SWD	Analog	Switch regulator port for digital
21	VSYS3V8D	Power	Input Power 3.6V
22	VBUCKD	Power	Switch regulator output for digital
23	LINR	Analog	Line in right channel
24	LINL	Analog	Line in left channel
25	MICINN	Analog	Microphone input negative
26	MICINP	Analog	Microphone input positive
27	V2MICBIAS	Analog	Audio bias voltage output
28	VERF1AUD	Analog	Audio reference output, 1.2V
29	VCCAUD	Power supply	Audio power supply input, 1.8V~3.6
30	AUDIOLN	Analog	Audio left channel output negative
31	AUDIOLP	Analog	Audio left channel output positive
32	AUDIORP	Analog	Audio right channel output negative
33	AUDIORN	Analog	Audio right channel output positive
34	VCC5USB	Power	USB power input
35	VCC4BAT	Power	Battery input
36	VCC3SYS	Power	3.6V system LDO output
37	SWA	Analog	Switch regulator port for analog
38	VCC3BUCKA	Power	Switch regulator input for analog
39	VBUCKA	Power	Switch regulator output for analog
40	VADC	Analog	Battery detector ADC input
41	NC	NC	NC
42	VCCBT	Power	BT power supply input, 1.8V~3.6
43	VCC3XTAL	Power	XTAL power input, 3.6V
44	XO	Analog	XTAL output
45	XI	Analog	XTAL input
46	TMS	Digital I/O	JTAG TMS
47	TCK	Digital I/O	JTAG TCK
48	TDO	Digital I/O	JTAG TDO



### 3. Functional Description

#### 3.1. GPIO

The BK8008 has total 19 GPIOs, which can be configured as either input or output. Most of them have second function.

**Table 2 GPIO Function Mapping**

功能分类	Mbist Mode	Perial Mode	GPIO Mode
GPIO0	Mbist Done	UART2_TXD/I2C2_SCL	General I/O
GPIO1	Mbist_Fail	UART2_RXD/I2C2_SDA	General I/O
GPIO2	input	pcm2_clk/TXEN	General I/O
GPIO3	input	pcm2_sync/RXEN	General I/O
GPIO4	input	pcm2_din/UART1_TX_Monitor	General I/O
GPIO5	input	pcm2_dout/UART1_RX_Monitor	General I/O
GPIO6	input	pcm2_codec_clk/spi_csn	General I/O
GPIO7	input	spi_sck	General I/O
GPIO8	input	spi_mosi	General I/O
GPIO9	input	spi_miso	General I/O
GPIO10	input	PWM0	General I/O
GPIO11	Mbist_Pass	PWM1	General I/O
GPIO12	input	sd_clk/clk13m	General I/O
GPIO13	input	sd_cmd/SCL	General I/O
GPIO14	input	sd_data[0]/SDA	General I/O
GPIO15	input	sd_data[1]	General I/O
GPIO16	input	sd_data[2]	General I/O
GPIO17	input	sd_data[3]	General I/O
GPIO18	Mbist_Fail_BT	jtag_TCK (上电默认)	General I/O
GPIO19	dram_result[2]	jtag_TMS (上电默认)	General I/O
GPIO20	dram_result[1]	jtag_TDI (上电默认)	General I/O
GPIO21	dram_result[0]	jtag_TDO (上电默认)	General I/O

All GPIO can be source to wake up MCU from shut down state. In shut down state, any level change on the set GPIO will trigger the wake up procedure.

When power on, the default state of GPIO0~GPIO9 and GPIO12~GPIO20 is high impedance and pull low internally; the default state of GPIO10~GPIO11 is high impedance and pull high; and the default state of GPIO21 is high impedance only.



### **3.2. PWM Timer and Watch Dog Timer**

There are two sets of PWM timers. One fast set uses 1 MHz clock as main clock, and another slow set uses 32 kHz clock as main clock. Each set has three 16 bits counter with 4 bit pre-divider. First two timers in slow set can be used to LED duty cycle control.

The watch dog timer runs with 32 kHz clock, with period from 0.6 ms to 38 second.

### **3.3. Power Management**

The BK8008 supports USB power supply that it can work without battery. When there is a USB power supply, it will charge the battery with automatically charge current control while provide power to the BK8008. The buck will give nearly half current reduction for digital power.

The BK8008 can enter into shut down mode when there is no active connection. The shut mode can be waked up by GPIO and USB charge.

### **3.4. MCU**

The 16 bit RISC MCU has 16 KB I-Cache and DMA bus, to support efficient execution and frequently data exchange. The JTAG interface can be used to on-line debug, which can be also configured as GPIO.

Besides 26 MHz crystal, the MCU can run with internal programmable ROOSC clock, or 32 kHz ring oscillator clock, with programmable divided ratio.

### **3.5. I2C and UART Interface**

There is one set of I2C interface and one set of UART interface for debug or external MCU control the BK8008. They share the two same GPIO0 and GPIO1.

### **3.6. FM Receiver Control Interface**



The FM receiver control interface consists of a two-wire I2C interface and a 13 MHz clock for FM receiver reference.

### 3.7. FLASH Access Interface

The BK8008 MCU is running with the external FLASH program memory and the internal instruction cache. The external FLASH can be also used to store user data such as key configuration and Bluetooth pairing information.

### 3.8. SPI

The 4-wires SPI supports high speed data communication, which can be used as interface to either external FLASH or LCD controller.

### 3.9. SAR ADC and LED

The SAR ADC has 10-bit resolution, and the two LED drivers support up to 10 mA current.

The SAR has six active channel as follows.

**Table 3 ADC Channel Table**

Channel Number	Detected Voltage	Description
1	VBAT-pin/4	Battery voltage
2	VADC-pin	Pin VADC voltage
3	Charge current detector	Used to detect charge current and charge circuit control
4	VCC5USB-pin/6	USB voltage
5	GPIO19	GPIO19 voltage
6	GPIO9	GPIO9 voltage

### 3.10. Audio Peripheral

There are one set of speech ADC with sample rate 8 kHz or 16 kHz, 44.1 kHz or 48 kHz. The DAC have two channels for stereo application, with sample rate 8 kHz, 16 kHz, 44.1 kHz or 48 kHz.



There is also a stereo line in interface, to allow external stereo input passing internal 31 dB programmable gain amplify to stereo output.

## 4. Electrical Characteristics

### 4.1. Absolute Maximum Ratings

Parameter	Description	MIN	TYP	MAX	Unit
VCCBAT	Battery regulator Supply voltage	-0.3	3.3	4.2	V
P <sub>RX</sub>	RX input power	-	10	-	dBm
T <sub>STR</sub>	Storage temperature range	-40	-	150	°C
VCCIO	IO interface voltage	-0.3	2.8	3.6	V

### 4.2. Recommended Operating Conditions

Parameter	Description	MIN	TYP	MAX	Unit
VCCBAT	Battery regulator Supply voltage	2.8	3.3	4.2	V
T <sub>OPR</sub>	Operation temperature range	-20	-	80	°C
VCCIO	IO interface voltage	1.8	-	4.2	V

### 4.3. System LDO

State	Description	MIN	TYP	MAX	Unit
VCC4BAT	VBAT	2.8		4.2	V
VCC3SYS	SYSLDO Output Voltage	2.8	3.6	3.8	V
Load Current	Loading Current			150	mA

### 4.4. Analog LDO/BUCK

System can choose the analog BUCK or LDO as the power supply of RF and Audio part.

State	Description	MIN	TYP	MAX	Unit
Analog LDO					
VCC3BUCKA	Analog LDO Input Voltage	2.8	3.3	3.6	V
VBUCKA	Analog LDO Output Voltage	1.7	1.8	2.4	V
Load Current	Loading Current			100	mA
Analog BUCK					
VCC3BUCKA	Analog BUCK Input Voltage	2.8	3.3	3.6	V
VBUCKA	Analog BUCK Output Voltage	1.7	1.8	2.4	V
Load Current	Loading Current			100	mA
Switching frequency	BUCK modulation frequency	2	5	10	MHz



#### 4.5. Digital LDO/BUCK

System can also choose the digital BUCK or LDO as the power supply for the Digital part.

State	Description	MIN	TYP	MAX	Unit
Digital LDO					
VSYS3V8D	Digital LDO Input Voltage	2.8	3.3	3.6	V
VBUCKD	Digital LDO Output Voltage		1.2	1.35	V
Load Current	Loading Current			100	mA
Digital BUCK					
VSYS3V8D	Digital BUCK Input Voltage	2.8	3.3	3.6	V
VBUCKD	Digital BUCK Output Voltage		1.2	1.35	V
Load Current	Loading Current			100	mA
Switching frequency	BUCK modulation frequency	2	5	10	MHz

#### 4.6. USB LDO

When USB is plug in, VCC3SYS will be generated from USB LDO.

State	Description	MIN	TYP	MAX	Unit
VCC5USB	USB Input Voltage	4.75	5	5.75	V
VCC3SYS	USBLDO Output Voltage		3.3		V
Load Current	Loading Current			100	mA

#### 4.7. Typical Power Consumption

State	Description	MIN	TYP	MAX	Unit
Shut down	Software shut down, wake up from GPIO		50		uA
Idle-Sniff	Idle state at Sniff mode		900		uA
Active (A2DP)	2DH5		20		mA
Active (HFP)	HV1		20		mA

#### 4.8. RF Characteristics

Parameter	Condition	MIN	TYP	MAX	Unit
Operate Frequency	2402~2480	2402		2480	MHz
RXSENS-1 Mbps	BER=0.001		-90		dBm
RXSENS-2 Mbps	BER=0.0001		-92		dBm
RXSENS-3 Mbps	BER=0.0001		-84		dBm
Maximum received signal	BER=0.001	0			dBm
Maximum RF transmit power			5		dBm
RF Power Control Range		30			dB



#### 4.9. Audio Characteristics

Parameter	Condition	MIN	TYP	MAX	Unit
DAC Output Amplitude				1	Vrms
DAC output SNR	1 kHz sine wave		96		dB
DAC Sample Rate		8		48	kHz
ADC SNR	1 kHz sine wave		96		dB
ADC Sample Rate		8		48	kHz

#### 5. Application Schematic

It will be provided with separate document.

#### 6. About the Qualification

By carefully PCB layout, the BK8008 RF performance meets FCC, CE and BQB requirement. The Bluetooth protocol and profile provided by Beken are already qualified and listed in SIG website. If there is any end product listing requirement with the BK8008, please inquire Beken for the related QDID authorization.

### 7. Package Information

The BK8008 uses the QFN 6x6 48-Pin package.

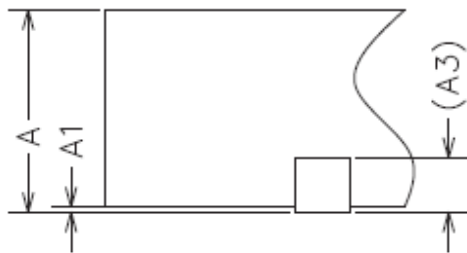
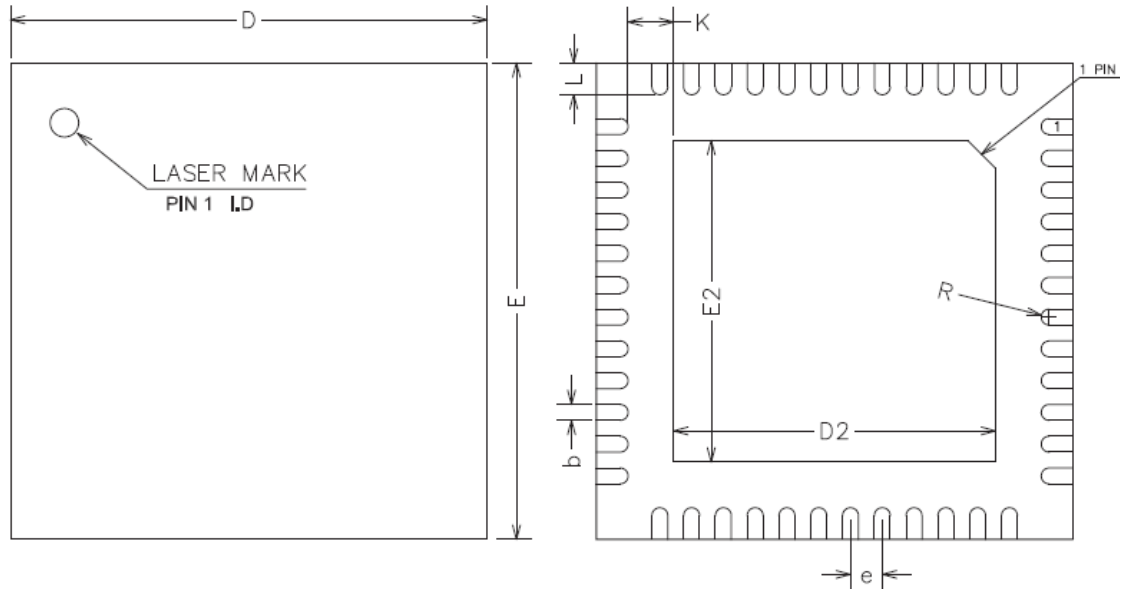

COMMON DIMENSIONS  
(UNITS OF MEASURE=MILLIMETER)

SYMBOL	MIN	NOM	MAX
A	0.70	0.75	0.80
A1	0	0.02	0.05
A3	0.20REF		
b	0.15	0.20	0.25
D	5.90	6.00	6.10
E	5.90	6.00	6.10
D2	3.95	4.05	4.15
E2	3.95	4.05	4.15
e	0.35	0.40	0.45
K	0.20	-	-
L	0.35	0.40	0.45
R	0.09	-	-





**8. Ordering Information**

<b>Part number</b>	<b>Package</b>	<b>Packing</b>	<b>MOQ (ea)</b>
BK8008	QFN 6mmx6mm 48-Pin	Tape Reel	10 k

**Remark:**

**MOQ: Minimum Order Quantity**