



Valued Quality. Delivered.

TEST REPORT

Report No.: 15120031HKG-002

Voxx Accessories Corp.

Application
For
Certification
(Original Grant)
(FCC ID: VIXAWSEE3)

Transceiver

Prepared and Checked by:

Approved by:

Signed On File
Wong Cheuk Ho, Herbert
Lead Engineer

Wong Kwok Yeung, Kenneth
Lead Engineer
Date: January 06, 2016

- Intertek's standard Terms and Conditions can be obtained at our website <http://www.intertek.com/terms/>.
- The test report only allows to be revised within the retention period unless further standard or the requirement was noticed.
- This report is for the exclusive use of Intertek's Client and is provided pursuant to the agreement between Intertek and its Client. Intertek's responsibility and liability are limited to the terms and conditions of the agreement. Intertek assumes no liability to any party, other than to the Client in accordance with the agreement, for any loss, expense or damage occasioned by the use of this report. Only the Client is authorized to permit copying or distribution of this report and then only in its entirety. Any use of the Intertek name or one of its marks for the sale or advertisement of the tested material, product or service must first be approved in writing by Intertek. The observations and test results in this report are relevant only to the sample tested. This report by itself does not imply that the material, product, or service is or has ever been under an Intertek certification program.

Intertek Testing Services Hong Kong Ltd.

2/F., Garment Centre, 576 Castle Peak Road, Kowloon, Hong Kong.
Tel: (852) 2173 8888 Fax: (852) 2785 5487 Website: www.hk.intertek-etlsemko.com

INTERTEK TESTING SERVICES

GENERAL INFORMATION

Grantee:	Voxx Accessories Corp.
Grantee Address:	3502 Woodview Trace suite 220 Indianapolis Indiana United States 46268
Contact Person:	Milan Phillabaum
Tel:	317-218-7302
Fax:	317-569-0284
e-mail:	mphillabaum@voxxintl.com
Manufacturer:	Acoustic Arc International Ltd.
Manufacturer Address:	110-112, 1/F., Philips Electronics Building, 5 Science Park East Avenue, Hong Kong Science Park, Shatin, N.T., Hong Kong
Brand Name:	AR
Model:	AWSEE3
Type of EUT:	Transceiver
Description of EUT:	Portable Bluetooth Speaker
Serial Number:	N/A
FCC ID:	VIXAWSEE3
Date of Sample Submitted:	December 01, 2015
Date of Test:	December 01, 2015 to December 31, 2015
Report No.:	15120031HKG-002
Report Date:	January 06, 2016
Environmental Conditions:	Temperature: +10 to 40°C Humidity: 10 to 90%

INTERTEK TESTING SERVICES

SUMMARY OF TEST RESULT

TEST SPECIFICATION	REFERENCE	RESULTS
Radiated Emission Radiated Emission on the Bandedge	15.249, 15.209	Pass
Radiated Emission in Restricted Bands	15.205	Pass

The equipment under test is found to be complying with the following standards:
FCC Part 15, October 1, 2014 Edition

- Note: 1. The EUT uses a permanently attached antenna which, in accordance to section 15.203, is considered sufficient to comply with the provisions of this section.
2. Pursuant to FCC part 15 Section 15.215(c), the 20 dB bandwidth of the emission was contained within the frequency band designated (mentioned as above) which the EUT operated. The effects, if any, from frequency sweeping, frequency hopping, other modulation techniques and frequency stability over excepted variations in temperature and supply voltage were considered.

INTERTEK TESTING SERVICES

Table of Contents

1.0	<u>General Description</u>	1
1.1	Product Description	1
1.2	Related Submittal(s) Grants	1
1.3	Test Methodology	1
1.4	Test Facility	1
2.0	<u>System Test Configuration</u>	2
2.1	Justification.....	2
2.2	EUT Exercising Software	2
2.3	Special Accessories.....	2
2.4	Measurement Uncertainty	2
2.5	Support Equipment List and Description.....	2
3.0	<u>Emission Results</u>	3
3.1	Field Strength Calculation	3
3.2	Radiated Emission Configuration Photograph	4
3.3	Radiated Emission Data	4
3.4	Conducted Emission Configuration Photograph	4
3.5	Conducted Emission Data.....	4
4.0	<u>Equipment Photographs</u>	11
5.0	<u>Product Labelling</u>	11
6.0	<u>Technical Specifications</u>	11
7.0	<u>Instruction Manual</u>	11
8.0	<u>Miscellaneous Information</u>	12
8.1	Radiated Emission on the Bandedge	12
8.2	Discussion of Pulse Desensitization	15
8.3	Calculation of Average Factor	15
8.4	Emissions Test Procedures	16
9.0	<u>Confidentiality Request</u>	20
10.0	<u>Equipment List</u>	20

INTERTEK TESTING SERVICES

1.0 General Description

1.1 Product Description

The Equipment Under Test (EUT) is a Portable Bluetooth Speaker with multi-mode lighting. It can accept audio signal from analog input sources (3.5mm phone jack Aux-in) and wireless Bluetooth device. The Bluetooth module in the EUT is operating in the frequency range from 2402MHz to 2480MHz (79 channels with 1MHz channel spacing). The audio signal is amplified and fed to the built-in passive loudspeaker. The EUT is powered by an AC/DC adaptor. (Input: 100-240VAC 50/60Hz 0.45A; Output: 14VDC 1.0A).

The EUT may come in color variations but are electrically and mechanically the same. The only difference is the color.

Antenna Type: Internal, Integral

For electronic filing, the brief circuit description is saved with filename: descri.pdf.

1.2 Related Submittal(s) Grants

This is a single application for certification of a transceiver.

1.3 Test Methodology

Both AC mains line-conducted and radiated emission measurements were performed according to the procedures in ANSI C63.10 (2013). All radiated measurements were performed in an 3m Chamber. Preliminary scans were performed in the 3m Chamber only to determine worst case modes. All radiated tests were performed at an antenna to EUT distance of 3 meters, unless stated otherwise in the “**Justification Section**” of this Application.

1.4 Test Facility

The 3m Chamber and conducted measurement facility used to collect the radiated data is located at Workshop No. 3, G/F., World-Wide Industrial Centre, 43-47 Shan Mei Street, Fo Tan, Sha Tin, N.T., Hong Kong. This test facility and site measurement data have been placed on file with the FCC.

INTERTEK TESTING SERVICES

2.0 System Test Configuration

2.1 Justification

The system was configured for testing in a typical fashion (as a customer would normally use it), and in the confines as outlined in ANSI C63.10 (2013).

The device was powered by 120VAC and or 11.1VDC rechargeable battery.

For maximizing emissions, the EUT was rotated through 360°, the antenna height was varied from 1 meter to 4 meters above the ground plane, and the antenna polarization was changed. This step by step procedure for maximizing emissions led to the data reported in Exhibit 3.0.

The rear of unit shall be flushed with the rear of the table.

The equipment under test (EUT) was configured for testing in a typical fashion (as a customer would normally use it). The EUT was mounted to a plastic stand if necessary and placed on the wooden turntable, which enabled the engineer to maximize emissions through its placement in the three orthogonal axes.

Both AC and DC power operations were tested. Worse case is AC power.

2.2 EUT Exercising Software

There was no special software to exercise the device. Once the unit is powered up, it transmits the RF signal continuously.

2.3 Special Accessories

There are no special accessories necessary for compliance of this product.

2.4 Measurement Uncertainty

When determining of the test conclusion, the Measurement Uncertainty of test has been considered.

Uncertainty and Compliance - Unless the standard specifically states that measured values are to be extended by the measurement uncertainty in determining compliance, all compliance determinations are based on the actual measured value.

2.5 Support Equipment List and Description

1. Audio cable of 1m in length (with termination)
2. AC/DC Adaptor, Model:K15V140100U;
I/P:100-240VAC 0.45A, O/P: 14VDC 1.0A
(Provided by Applicant)

INTERTEK TESTING SERVICES

3.0 Emission Results

Data is included of the worst case configuration (the configuration which resulted in the highest emission levels). A sample calculation, configuration photographs and data tables of the emissions are included.

3.1 Field Strength Calculation

The field strength is calculated by adding the Antenna Factor and Cable Factor, and subtracting the Amplifier Gain (if any), Average Factor (optional) from the measured reading. The basic equation with a sample calculation is as follows:

$$FS = RA + AF + CF - AG - AV$$

where

- FS = Field Strength in dB μ V/m
- RA = Receiver Amplitude (including preamplifier) in dB μ V
- CF = Cable Attenuation Factor in dB
- AF = Antenna Factor in dB
- AG = Amplifier Gain in dB
- AV = Average Factor in dB

In the following table(s), the reading shown on the data table reflects the preamplifier gain. An example for the calculations in the following table is as follows:

$$FS = RR + LF$$

where

- FS = Field Strength in dB μ V/m
- RR = RA - AG - AV in dB μ V
- LF = CF + AF in dB

Assume a receiver reading of 52.0 dB μ V is obtained. The antenna factor of 7.4 dB and cable factor of 1.6 dB are added. The amplifier gain of 29 dB and average factor of 5 dB are subtracted, giving a field strength of 32 dB μ V/m. This value in dB μ V/m was converted to its corresponding level in μ V/m.

RA = 52.0 dB μ V/m	
AF = 7.4 dB	RR = 18.0 dB μ V
CF = 1.6 dB	LF = 9.0 dB
AG = 29.0 dB	
AV = 5.0 dB	
FS = RR + LF	
FS = 18 + 9 = 27 dB μ V/m	

Level in μ V/m = Common Antilogarithm [(27 dB μ V/m)/20] = 22.4 μ V/m

INTERTEK TESTING SERVICES

3.2 Radiated Emission Configuration Photograph

The worst case in radiated emission was found at 192.027 MHz

For electronic filing, the worst case radiated emission configuration photographs are saved with filename: radiated photos.pdf.

3.3 Radiated Emission Data

The data on the following page lists the significant emission frequencies, the limit and the margin of compliance. Numbers with a minus sign are below the limit.

Judgment: Passed by 0.5 dB

3.4 Conducted Emission Configuration Photograph

The worst case in line-conducted emission was found at 0.434 MHz

For electronic filing, the worst case line-conducted configuration photographs are saved with filename: conducted photo.pdf.

3.5 Conducted Emission Data

For electronic filing, the graph and data table of conducted emission is saved with filename: conducted.pdf.

Judgment: Pass by 12.7 dB

INTERTEK TESTING SERVICES

Worst-Case Operating Mode: Bluetooth sound playing with Light mode

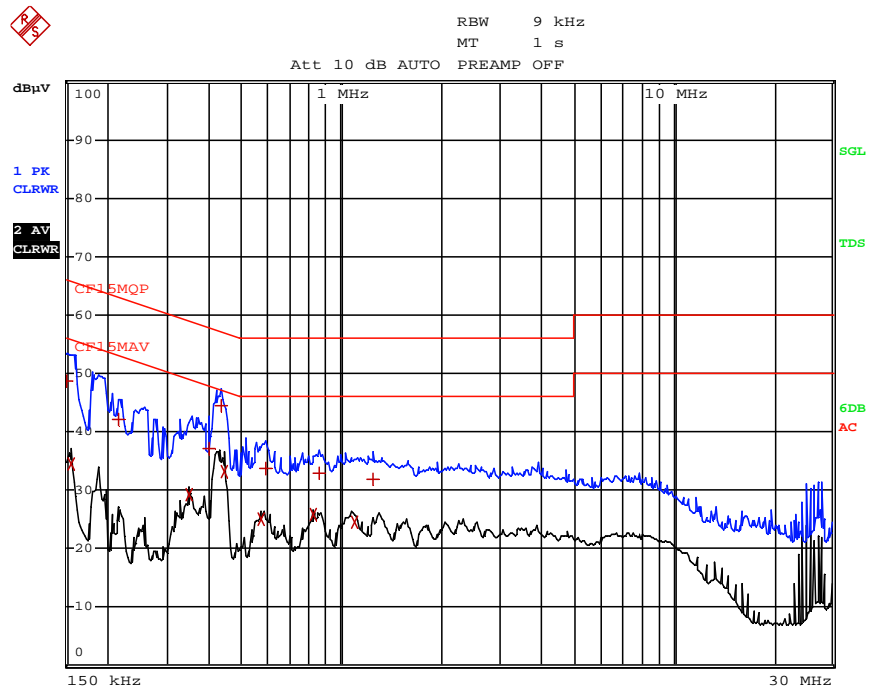

Note: Measurement Uncertainty is ± 4.2 dB at a level of confidence of 95%.

INTERTEK TESTING SERVICES

Worst-Case Operating Mode: Bluetooth sound playing with Light mode

EDIT PEAK LIST (Final Measurement Results)				
TRACE	FREQUENCY	LEVEL dBµV	DELTA	LIMIT dB
Trace1:	CF15MQP			
Trace2:	CF15MAV			
Trace3:	---			
1	Quasi Peak 150 kHz	48.69 L1		-17.30
2	CISPR Average 154.5 kHz	34.43 N		-21.32
1	Quasi Peak 217.5 kHz	42.25 N		-20.65
2	CISPR Average 348 kHz	29.15 N		-19.86
1	Quasi Peak 397.5 kHz	37.18 N		-20.72
1	Quasi Peak 433.5 kHz	44.44 N		-12.74
2	CISPR Average 442.5 kHz	33.15 L1		-13.86
2	CISPR Average 573 kHz	25.08 L1		-20.91
1	Quasi Peak 591 kHz	33.85 N		-22.14
2	CISPR Average 825 kHz	25.82 N		-20.17
1	Quasi Peak 856.5 kHz	33.05 L1		-22.94
2	CISPR Average 1.0995 MHz	24.48 L1		-21.52
1	Quasi Peak 1.2435 MHz	31.92 L1		-24.07

Note: Measurement Uncertainty is ± 4.2 dB at a level of confidence of 95%.

INTERTEK TESTING SERVICES

Company: Voxx Accessories Corp.
 Model: AWSEE3

Date of Test: December 31, 2015

Worst-Case Operating Mode: Transmitting (Bluetooth 2.1) with Light mode

Table 1
Radiated Emissions
Pursuant to FCC Part 15 Section 15.249 Requirement

Lowest Channel

Polarization	Frequency (MHz)	Reading (dBμV)	Pre-Amp Gain (dB)	Antenna Factor (dB)	Net at 3m - Peak (dBμV/m)	Average Factor (dB)	Calculated at 3m (dBμV/m)	Average Limit at 3m (dBμV/m)	Margin (dB)
V	2402.000	92.4	33	29.4	88.8	24	64.8	94.0	-29.2
V	4804.000	55.5	33	34.9	57.4	24	33.4	54.0	-20.6
V	7206.000	50.9	33	37.9	55.8	24	31.8	54.0	-22.2
V	9608.000	49.8	33	40.4	57.2	24	33.2	54.0	-20.8
V	12010.000	51.9	33	40.5	59.4	24	35.4	54.0	-18.6
V	14412.000	53.8	33	40.0	60.8	24	36.8	54.0	-17.2

Polarization	Frequency (MHz)	Reading (dBμV)	Pre-Amp Gain (dB)	Antenna Factor (dB)	Net at 3m - Peak (dBμV/m)	Peak Limit at 3m (dBμV/m)	Margin (dB)
V	2402.000	92.4	33	29.4	88.8	114.0	-25.2
V	4804.000	55.5	33	34.9	57.4	74.0	-16.6
V	7206.000	50.9	33	37.9	55.8	74.0	-18.2
V	9608.000	49.8	33	40.4	57.2	74.0	-16.8
V	12010.000	51.9	33	40.5	59.4	74.0	-14.6
V	14412.000	53.8	33	40.0	60.8	74.0	-13.2

- NOTES: 1. Peak Detector Data unless otherwise stated.
2. All measurements were made at 3 meters. Harmonic emissions not detected at the 3-meter distances were measured at 0.3-meter and an inverse proportional extrapolation was performed to compare the signal level to the 3-meter limit. No other harmonic emissions than those reported were detected at a test distance of 0.3-meter.
3. Negative sign in the column shows value below limit.
4. Horn antenna is used for the emission over 1000MHz.
5. Emission (the row indicated by **bold italic**) within the restricted band meets the requirement of FCC Part 15 Section 15.205.
6. Measurement Uncertainty is ±5.3dB at a level of confidence of 95%.

INTERTEK TESTING SERVICES

Company: Voxx Accessories Corp.
 Model: AWSEE3

Date of Test: December 31, 2015

Worst-Case Operating Mode: Transmitting (Bluetooth 2.1) with Light mode

Table 2
Radiated Emissions
Pursuant to FCC Part 15 Section 15.249 Requirement

Middle Channel

Polarization	Frequency (MHz)	Reading (dBμV)	Pre-Amp Gain (dB)	Antenna Factor (dB)	Net at 3m - Peak (dBμV/m)	Average Factor (dB)	Calculated at 3m (dBμV/m)	Average Limit at 3m (dBμV/m)	Margin (dB)
V	2440.000	92.0	33	29.4	88.4	24	64.4	94.0	-29.6
V	4880.000	55.7	33	34.9	57.6	24	33.6	54.0	-20.4
V	7320.000	50.5	33	37.9	55.4	24	31.4	54.0	-22.6
V	9760.000	50.2	33	40.4	57.6	24	33.6	54.0	-20.4
V	12200.000	51.7	33	40.5	59.2	24	35.2	54.0	-18.8
V	14640.000	55.2	33	38.4	60.6	24	36.6	54.0	-17.4

Polarization	Frequency (MHz)	Reading (dBμV)	Pre-Amp Gain (dB)	Antenna Factor (dB)	Net at 3m - Peak (dBμV/m)	Peak Limit at 3m (dBμV/m)	Margin (dB)
V	2440.000	92.0	33	29.4	88.4	114.0	-25.6
V	4880.000	55.7	33	34.9	57.6	74.0	-16.4
V	7320.000	50.5	33	37.9	55.4	74.0	-18.6
V	9760.000	50.2	33	40.4	57.6	74.0	-16.4
V	12200.000	51.7	33	40.5	59.2	74.0	-14.8
V	14640.000	55.2	33	38.4	60.6	74.0	-13.4

- NOTES: 1. Peak Detector Data unless otherwise stated.
2. All measurements were made at 3 meters. Harmonic emissions not detected at the 3-meter distances were measured at 0.3-meter and an inverse proportional extrapolation was performed to compare the signal level to the 3-meter limit. No other harmonic emissions than those reported were detected at a test distance of 0.3-meter.
3. Negative sign in the column shows value below limit.
4. Horn antenna is used for the emission over 1000MHz.
5. Emission (the row indicated by **bold italic**) within the restricted band meets the requirement of FCC Part 15 Section 15.205.
6. Measurement Uncertainty is ±5.3dB at a level of confidence of 95%.

INTERTEK TESTING SERVICES

Company: Voxx Accessories Corp.
 Model: AWSEE3

Date of Test: December 31, 2015

Worst-Case Operating Mode: Transmitting (Bluetooth 2.1) with Light mode

Table 3
Radiated Emissions
Pursuant to FCC Part 15 Section 15.249 Requirement

Highest Channel

Polarization	Frequency (MHz)	Reading (dBμV)	Pre-Amp Gain (dB)	Antenna Factor (dB)	Net at 3m - Peak (dBμV/m)	Average Factor (dB)	Calculated at 3m (dBμV/m)	Average Limit at 3m (dBμV/m)	Margin (dB)
V	2480.000	92.2	33	29.4	88.6	24	64.6	94.0	-29.4
V	4960.000	55.9	33	34.9	57.8	24	33.8	54.0	-20.2
V	7440.000	50.9	33	37.9	55.8	24	31.8	54.0	-22.2
V	9920.000	50.0	33	40.4	57.4	24	33.4	54.0	-20.6
V	12400.000	52.3	33	40.5	59.8	24	35.8	54.0	-18.2
V	14880.000	55.4	33	38.4	60.8	24	36.8	54.0	-17.2

Polarization	Frequency (MHz)	Reading (dBμV)	Pre-Amp Gain (dB)	Antenna Factor (dB)	Net at 3m - Peak (dBμV/m)	Peak Limit at 3m (dBμV/m)	Margin (dB)
V	2480.000	92.2	33	29.4	88.6	114.0	-25.4
V	4960.000	55.9	33	34.9	57.8	74.0	-16.2
V	7440.000	50.9	33	37.9	55.8	74.0	-18.2
V	9920.000	50.0	33	40.4	57.4	74.0	-16.6
V	12400.000	52.3	33	40.5	59.8	74.0	-14.2
V	14880.000	55.4	33	38.4	60.8	74.0	-13.2

- NOTES: 1. Peak Detector Data unless otherwise stated.
2. All measurements were made at 3 meters. Harmonic emissions not detected at the 3-meter distances were measured at 0.3-meter and an inverse proportional extrapolation was performed to compare the signal level to the 3-meter limit. No other harmonic emissions than those reported were detected at a test distance of 0.3-meter.
3. Negative sign in the column shows value below limit.
4. Horn antenna is used for the emission over 1000MHz.
5. Emission (the row indicated by **bold italic**) within the restricted band meets the requirement of FCC Part 15 Section 15.205.
6. Measurement Uncertainty is ±5.3dB at a level of confidence of 95%.

INTERTEK TESTING SERVICES

Company: Voxx Accessories Corp.
 Model: AWSEE3

Date of Test: December 31, 2015

Worst-Case Operating Mode: Sound play (Bluetooth Link) with Light mode

Table 4
Radiated Emissions
Pursuant to FCC Part 15 Section 15.209 Requirement

Polarization	Frequency (MHz)	Reading (dBμV)	Pre-amp (dB)	Antenna Factor (dB)	Net at 3m (dBμV/m)	Limit at 3m (dBμV/m)	Margin (dB)
V	47.460	37.0	16	11.0	32.0	40.0	-8.0
V	67.350	43.3	16	8.0	35.3	40.0	-4.7
V	99.552	34.4	16	12.0	30.4	43.5	-13.1
V	170.310	34.3	16	18.0	36.3	43.5	-7.2
V	192.027	43.0	16	16.0	43.0	43.5	-0.5
V	197.510	40.8	16	16.0	40.8	43.5	-2.7
V	202.580	42.1	16	16.0	42.1	43.5	-1.4
V	213.130	41.0	16	17.0	42.0	43.5	-1.5
V	224.004	34.5	16	18.0	36.5	46.0	-9.5
V	277.480	33.0	16	22.0	39.0	46.0	-7.0
V	287.520	32.7	16	22.0	38.7	46.0	-7.3
V	383.960	27.4	16	24.0	35.4	46.0	-10.6
V	406.003	24.2	16	24.0	32.2	46.0	-13.8
V	447.100	24.0	16	26.0	34.0	46.0	-12.0
V	467.990	22.5	16	26.0	32.5	46.0	-13.5
V	491.880	20.0	16	26.0	30.0	46.0	-16.0

NOTES: 1. Peak Detector Data unless otherwise stated.

2. All measurements were made at 3 meters. Harmonic emissions not detected at the 3-meter distances were measured at 0.3-meter and an inverse proportional extrapolation was performed to compare the signal level to the 3-meter limit. No other harmonic emissions than those reported were detected at a test distance of 0.3-meter.
3. Negative sign in the column shows value below limit.
4. Horn antenna is used for the emission over 1000MHz.
5. Emission (the row indicated by **bold italic**) within the restricted band meets the requirement of FCC Part 15 Section 15.205.
6. Measurement Uncertainty is ± 5.3 dB at a level of confidence of 95%.

INTERTEK TESTING SERVICES

4.0 Equipment Photographs

For electronic filing, the photographs are saved with filename: external photos.pdf and internal photos.pdf.

5.0 Product Labelling

For electronics filing, the FCC ID label artwork and the label location are saved with filename: label.pdf.

6.0 Technical Specifications

For electronic filing, the block diagram and schematic of the tested EUT are saved with filename: block.pdf and circuit.pdf respectively.

7.0 Instruction Manual

For electronic filing, a preliminary copy of the Instruction Manual is saved with filename: manual.pdf.

This manual will be provided to the end-user with each unit sold/leased in the United States.

INTERTEK TESTING SERVICES

8.0 **Miscellaneous Information**

The miscellaneous information includes details of the test procedure and measured bandwidth / calculation of factor such as pulse desensitization and averaging factor (calculation and timing diagram).

8.1 Radiated Emission on the Bandedge

From the following plots, they show that the fundamental emissions are confined in the specified band (2400MHz to 2483.5MHz). In case of the fundamental emissions are within two standard bandwidths from the bandedge, the delta measurement technique is used for determining bandedge compliance. Standard bandwidth is the bandwidth specified by ANSI C63.10 (2013) for frequency being measured.

Emissions radiated outside of the specified frequency bands, except harmonics, are attenuated by 50dB below the level of the fundamental or to the general radiated emissions limits in Section 15.209, whichever is the lesser attenuation, which meet the requirement of part 15.249(d).

INTERTEK TESTING SERVICES

Peak Measurement

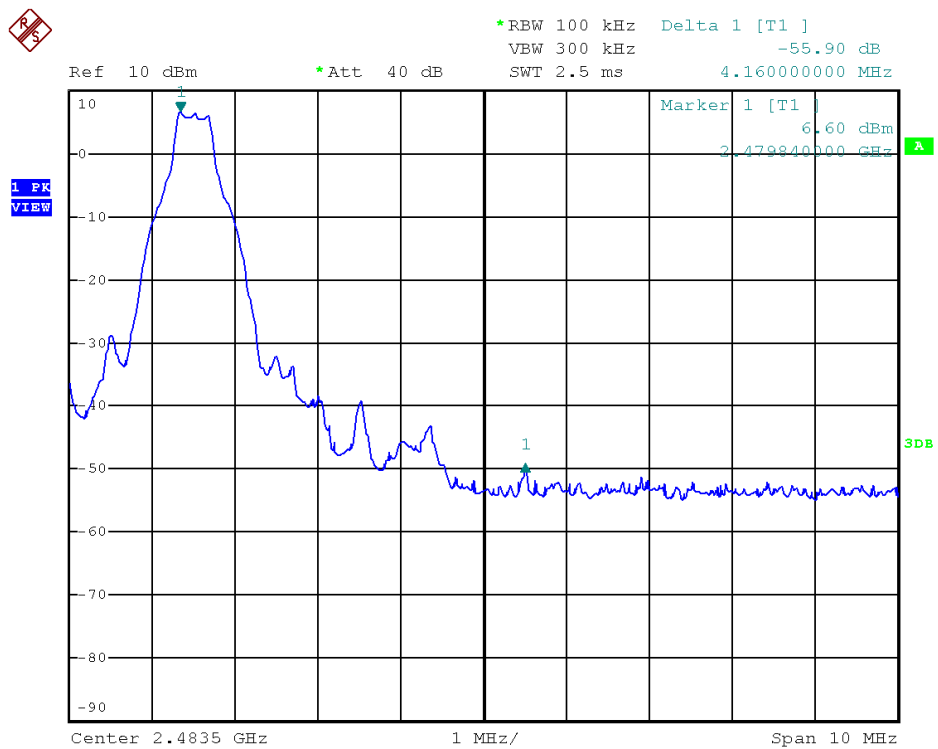
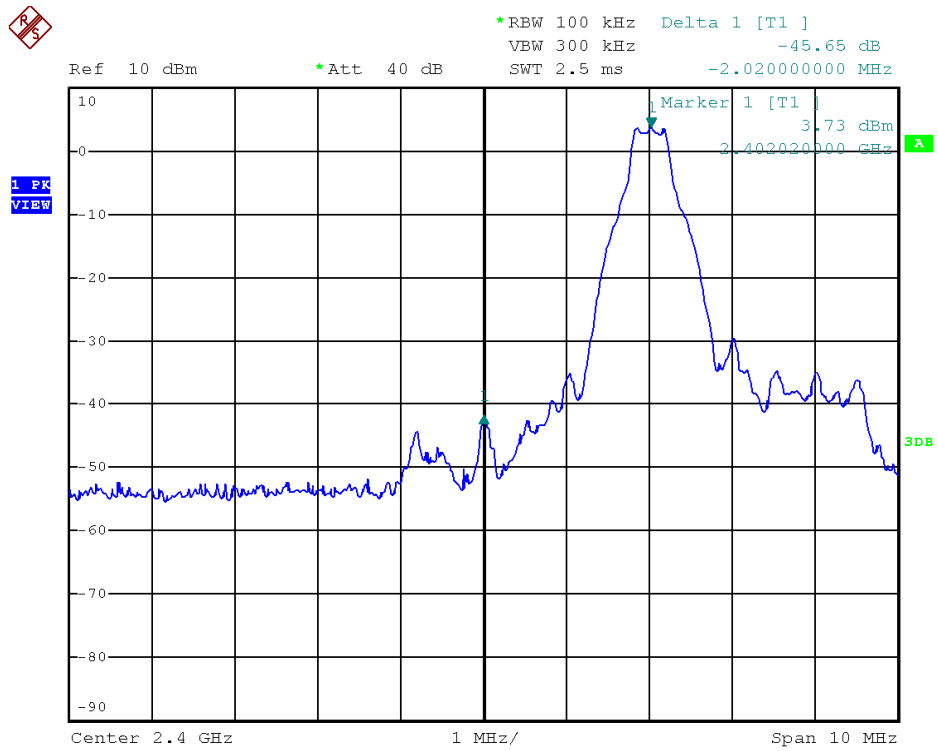

INTERTEK TESTING SERVICES

Peak Measurement

Bandedge compliance is determined by applying marker-delta method, i.e. (Bandedge Plot).

Lower bandedge

Peak Resultant field strength = Fundamental emissions (peak value) – delta from the plot

$$=88.8 \text{ dB}\mu\text{V/m} - 45.7 \text{ dB}$$

$$=43.1 \text{ dB}\mu\text{V/m}$$

Average Resultant field strength = Fundamental emissions (average value) – delta from the plot

$$=64.8 \text{ dB}\mu\text{V/m} - 45.7 \text{ dB}$$

$$=19.1 \text{ dB}\mu\text{V/m}$$

Upper bandedge

Peak Resultant field strength = Fundamental emissions (peak value) – delta from the plot

$$=88.6 \text{ dB}\mu\text{V/m} - 55.9 \text{ dB}$$

$$=32.7 \text{ dB}\mu\text{V/m}$$

Average Resultant field strength = Fundamental emissions (average value) – delta from the plot

$$=64.6 \text{ dB}\mu\text{V/m} - 55.9 \text{ dB}$$

$$=8.7 \text{ dB}\mu\text{V/m}$$

The resultant field strength meets the general radiated emission limit in Section 15.209, which does not exceed 74 dB μ V/m (Peak Limit) and 54 dB μ V/m (Average Limit).

INTERTEK TESTING SERVICES

8.2 Discussion of Pulse Desensitization

Pulse desensitivity is not applicable for this device. The effective period (T_{eff}) is approximately $625\mu s$ for a digital "1" bit which illustrated on technical specification, with a resolution bandwidth (3dB) of 1MHz, so the pulse desensitivity factor is 0dB.

8.3 Calculation of Average Factor

Based on the Bluetooth Specification Version 2.1 + EDR, the transmitter ON time for each timeslot of Bluetooth is $625\mu s$. DH5 has the maximum duty cycle, which consists of 5 continuous Tx slots and 1 Rx slot. Therefore one hopset take $(5+1) \times 625\mu s = 3.75ms$. For one period for a pseudo-random hopping through at least 20 RF channels in adaptive mode (worse case), it take: $20 \times 3.75ms = 75ms$.

The dwell time for DH5 is $5 \times 625\mu s = 3.125ms$.

For the worst case calculation, there are two transmissions might occur in 100ms. Therefore,

$$\begin{aligned} \text{Duty Cycle (DC)} &= \text{Maximum On time in } 100ms/100ms \\ &= 3.125ms \times 2/100ms \\ &= 0.0625 \end{aligned}$$

$$\begin{aligned} \text{Average Factor (AF) of Bluetooth in dB} &= 20 \log_{10} (0.0625) \\ &= -24 \text{ dB} \end{aligned}$$

INTERTEK TESTING SERVICES

8.4 Emissions Test Procedures

The following is a description of the test procedure used by Intertek Testing Services Hong Kong Ltd. in the measurements of transmitter operating under the Part 15, Subpart C rules.

The transmitting equipment under test (EUT) is placed on a wooden turntable which is four feet in diameter and approximately 0.8m in height above the ground plane for emission measurement at or below 1GHz and 1.5m in height above the ground plane for emission measurement above 1GHz. During the radiated emissions test, the turntable is rotated and any cables leaving the EUT are manipulated to find the configuration resulting in maximum emissions. The EUT is adjusted through all three orthogonal axis to obtain maximum emission levels. The antenna height and polarization are also varied during the testing to search for maximum signal levels. The height of the antenna is varied from one to four meters.

Detector function for radiated emissions is in peak mode. Average readings, when required, are taken by measuring the duty cycle of the equipment under test and subtracting the corresponding amount in dB from the measured peak readings. A detailed description for the calculation of the average factor can be found in Exhibit 8.3.

The frequency range scanned is from the lowest radio frequency signal generated in the device which is greater than 9 kHz to the tenth harmonic of the highest fundamental frequency or 40 GHz, whichever is lower. For line conducted emissions, the range scanned is 150 kHz to 30 MHz.

INTERTEK TESTING SERVICES

8.4 Emissions Test Procedures (cont'd)

The EUT is warmed up for 15 minutes prior to the test.

AC power to the unit is varied from 85% to 115% nominal and variation in the fundamental emission field strength is recorded. If battery powered, a new, fully charged battery is used.

Conducted measurements were made as described in ANSI C63.10 (2013).

The IF bandwidth used for measurement of radiated signal strength was 100 kHz or greater when frequency is below 1000 MHz. Where pulsed transmissions of short enough pulse duration warrant, a greater bandwidth is selected according to the recommendations of Hewlett Packard Application Note 150-2. A discussion of whether pulse desensitivity is applicable to this unit is included in this report (See Exhibit 8.1). Above 1000 MHz, a resolution bandwidth of 1 MHz is used.

Transmitter measurements are normally conducted at a measurement distance of three meters. However, to assure low enough noise floor in the forbidden bands and above 1 GHz, signals are acquired at a distance of one meter or less. All measurements are extrapolated to three meters using inverse scaling, unless otherwise reported. Measurements taken at a closer distance are so marked.

INTERTEK TESTING SERVICES

8.4.1 Radiated Emission Test Setup

The figure below shows the test setup, which is utilized to make these measurements.

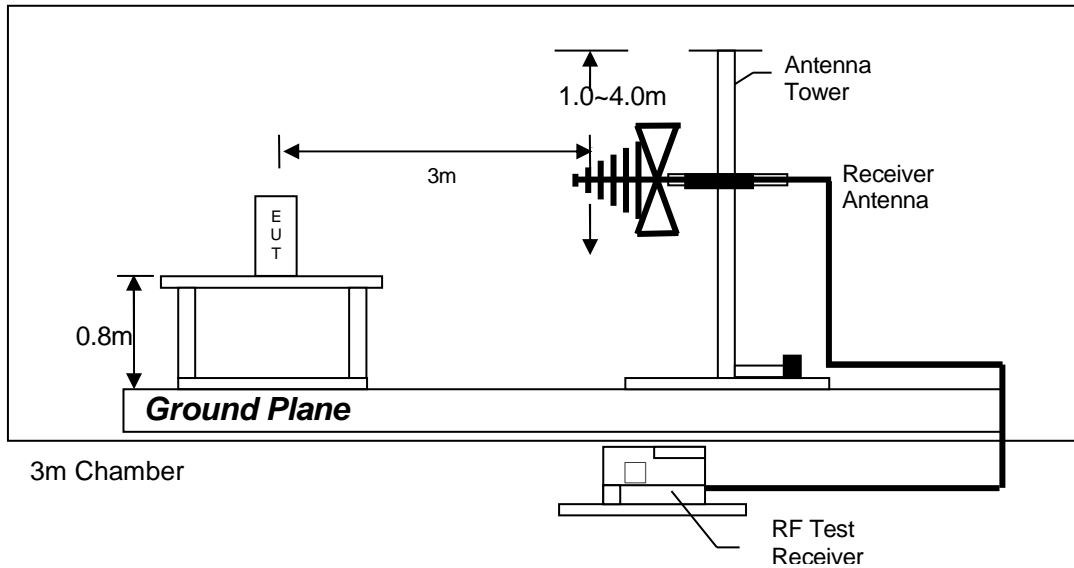

Test setup of radiated emissions up to 1GHz

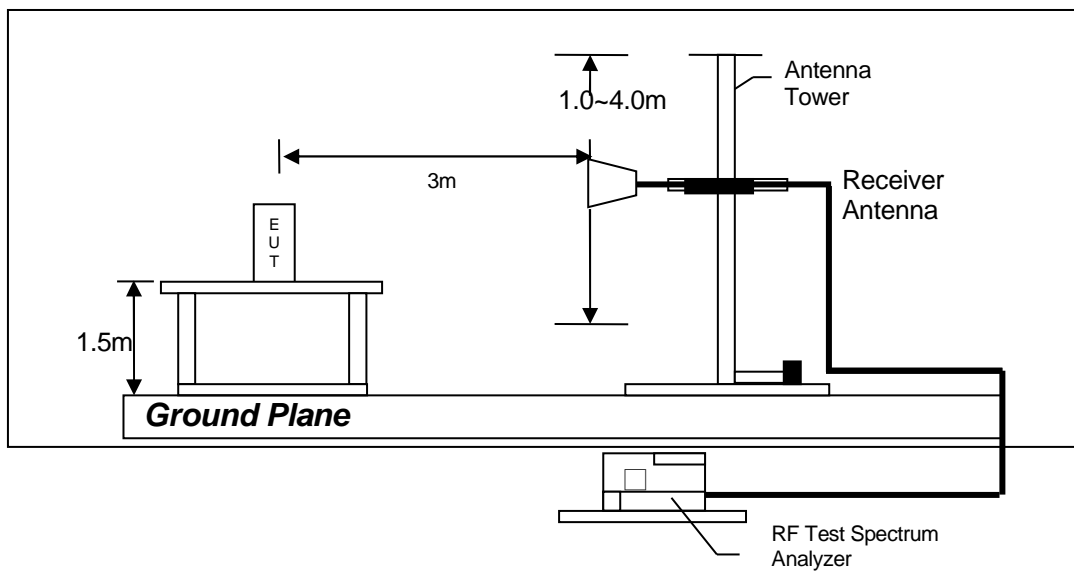

Test setup of radiated emissions above 1GHz

INTERTEK TESTING SERVICES

8.4.2 Conducted Emission Test Procedures

For tabletop equipment, the EUT along with its peripherals were placed on a 1.0m(W)×1.5m(L) and 0.8m in height wooden table. For floor-standing equipment, the EUT and all cables were insulated, if required, from the ground plane by up to 12 mm of insulating material. The EUT was adjusted to maintain a 0.4 meter space from a vertical reference plane. The EUT was connected to power mains through a line impedance stabilization network (LISN), which provided 50 ohm coupling impedance for measuring instrument and the chassis ground was bounded to the horizontal ground plane of shielded room. The excess power cable between the EUT and the LISN was bundled.

All connecting cables of EUT and peripherals were moved to find the maximum emission.

8.4.3 Conducted Emission Test Setup

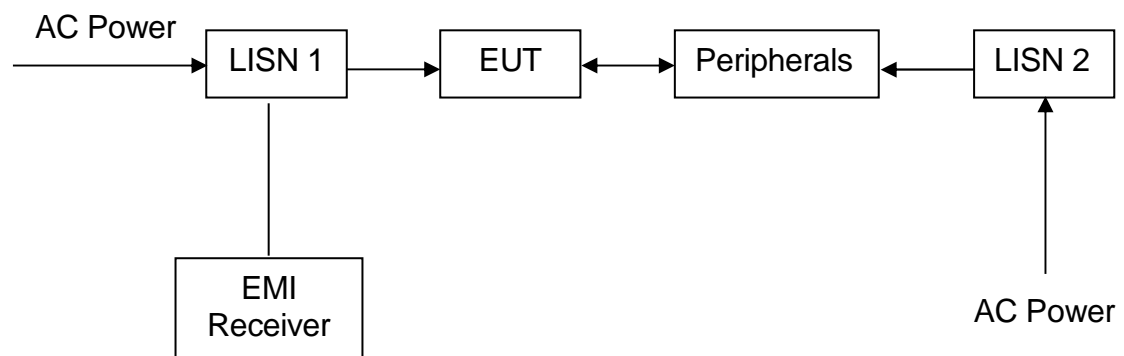

INTERTEK TESTING SERVICES

9.0 Confidentiality Request

For electronic filing, a preliminary copy of the confidentiality request is saved with filename: request.pdf.

10.0 Equipment List

1) Radiated Emissions Test

Equipment	EMI Test Receiver	Spectrum Analyzer
Registration No.	EW-3095	EW-2253
Manufacturer	R&S	R&S
Model No.	ESCI	FSP40
Calibration Date	Nov. 05, 2015	May 27, 2015
Calibration Due Date	Nov. 05, 2016	May 27, 2016

Equipment	BiConiLog Antenna	Double Ridged Guide Antenna
Registration No.	EW-3061	EW-0194
Manufacturer	EMCO	EMCO
Model No.	3412E	3115
Calibration Date	Jul. 22, 2015	Jan. 29, 2015
Calibration Due Date	Jul. 22, 2016	Jul. 29, 2016

2) Conducted Emissions Test

Equipment	EMI Test Receiver	LISN
Registration No.	EW-3095	EW-2501
Manufacturer	R&S	R&S
Model No.	ESCI	ENV-216
Calibration Date	Nov. 05, 2015	Jan. 01, 2015
Calibration Due Date	Nov. 05, 2016	Jan. 01, 2016

3) Bandedge Measurement

Equipment	Spectrum Analyzer
Registration No.	EW-2329
Manufacturer	R&S
Model No.	FSP3
Calibration Date	Jun. 17, 2015
Calibration Due Date	Jun. 17, 2016

END OF TEST REPORT