



**FCC 47 CFR PART 15 SUBPART C**

**TEST REPORT**

**For**

**Wireless Bluetooth Speaker**

**Model: AWSBT7, AWSBT6, AWSBT8**

**Brand: Acoustic Research**

**Test Report Number:**

**C121114Z03-RP1**

*Prepared for*

**Voxx Accessories Corp.**

**3502 Woodview Trace, Suite 220 Indianapolis, Indiana.**

**United States 46268**

*Prepared by*

**COMPLIANCE CERTIFICATION SERVICES (SHENZHEN) INC.**

**No.10-1, Mingkeda Logistics Park, No.18, Huanguan South Rd.,**

**Guan Lan Town, Baoan District, Shenzhen China**

**TEL: 86-755-28055000**

**FAX: 86-755-28055221**

**Issued Date: December 17, 2012**



TESTING CERT #2861.01

**Note:** This report shall not be reproduced except in full, without the written approval of Compliance Certification Services Inc. This document may be altered or revised by Compliance Certification Services Inc. personnel only, and shall be noted in the revision section of the document. The client should not use it to claim product endorsement by TAF, A2LA, NVLAP, NIST or any government agencies. The test result of this report relate only to the tested sample identified in this report.



Revision History

Rev.	Issue No.	Revisions	Effect Page	Revised By
00	C121114Z03-RP1	Initial Issue	ALL	Anna Liu



**TABLE OF CONTENTS**

**1. TEST RESULT CERTIFICATION .....4**

**2. EUT DESCRIPTION.....5**

**3. TEST METHODOLOGY.....6**

    3.1 DESCRIPTION OF TEST MODES.....6

**4. FACILITIES AND ACCREDITATIONS .....7**

    4.1 FACILITIES.....7

    4.2 ACCREDITATIONS .....7

    4.3 MEASUREMENT UNCERTAINTY .....7

**5. SETUP OF EQUIPMENT UNDER TEST .....8**

    5.1 SETUP CONFIGURATION OF EUT .....8

    5.2 SUPPORT EQUIPMENT .....8

**6. FCC PART 15.247 REQUIREMENTS .....9**

    6.1 20dB BANDWIDTH.....9

    6.2 PEAK POWER.....14

    6.3 PEAK POWER SPECTRAL DENSITY .....15

    6.4 BAND EDGES MEASUREMENT .....17

    6.5 FREQUENCY SEPARATION .....27

    6.6 NUMBER OF HOPPING FREQUENCY .....30

    6.7 TIME OF OCCUPANCY (DWELL TIME).....33

    6.8 SPURIOUS EMISSIONS.....40

    6.9 POWERLINE CONDUCTED EMISSIONS .....58



### 1. TEST RESULT CERTIFICATION

<b>Product:</b>	Wireless Bluetooth Speaker
<b>Model:</b>	AWSBT7, AWSBT6, AWSBT8
<b>Brand:</b>	Acoustic Research
<b>Tested:</b>	November 14–December 14, 2012
<b>Applicant:</b>	<b>Voxx Accessories Corp.</b> 3502 Woodview Trace, Suite 220 Indianapolis, Indiana. United States 46268
<b>Manufacturer:</b>	<b>Uni-Art Precise Products Ltd</b> 11-12/F, Yue Xiu Industrial Building, 87 Hung To Road, Kowloon, Hong Kong

APPLICABLE STANDARDS	
STANDARD	TEST RESULT
FCC 47 CFR Part 15 Subpart C	No non-compliance noted

#### We hereby certify that:

The above equipment was tested by Compliance Certification Services Inc. The test data, data evaluation, test procedures, and equipment configurations shown in this report were made in accordance with the procedures given in ANSI C63.4:2009 and the energy emitted by the sample EUT tested as described in this report is in compliance with conducted and radiated emission limits of FCC Rules Part 15.207, 15.209 and 15.247.

The test results of this report relate only to the tested sample EUT identified in this report.

**Approved by:**

---

**Tom Gan**  
Supervisor of EMC Dept.  
Compliance Certification Service Inc.

**Reviewed by:**

---

**Ruby Zhang**  
Supervisor of Report Dept.  
Compliance Certification Service Inc.



## 2. EUT DESCRIPTION

<b>Product</b>	Wireless Bluetooth Speaker
<b>Model Number</b>	AWSBT7, AWSBT6, AWSBT8
<b>Brand</b>	Acoustic Research
<b>Model Discrepancy</b>	Just their model name are different.
<b>Identify Number</b>	C121114Z03-RP1
<b>Power Supply</b>	DC10V supplied by the adapter or DC9V supplied by the batteries
<b>Received Date</b>	November 14, 2012
<b>Frequency Range</b>	2402 ~ 2480 MHz
<b>Transmit Power</b>	GFSK : 0.23dBm 8DPSK :-1.77dBm
<b>Modulation Technique</b>	FHSS (GFSK for 1Mbps, $\pi/4$ -DQPSK for 2Mbps, 8DPSK for 3Mbps)
<b>Number of Channels</b>	79 Channels
<b>Antenna Specification</b>	Ceramic Antenna with 2dBi gain(Max)
<b>Temperature Range</b>	-10°C ~ +55°C

**Note:** This submittal(s) (test report) is intended for FCC ID: VIXAUDAWSBTRX filing to comply with Section 15.207, 15.209 and 15.247 of the FCC Part 15, Subpart C Rules.



### 3. TEST METHODOLOGY

#### 3.1 DESCRIPTION OF TEST MODES

The EUT has been tested under operating condition.

Test program used to control the EUT for staying in continuous transmitting and receiving mode is programmed.

The following test mode(s) were scanned during the preliminary test below 1G:

Test Item	Test mode	Worse mode
Conducted Emission	Mode 1: Normal	<input checked="" type="checkbox"/>
Radiated Emission	Mode 1: TX	<input checked="" type="checkbox"/>

Above 1G, Channel Low (2402MHz) · Mid (2441MHz) and High (2480MHz) were chosen for full testing for GFSK and 8DPSK.



## 4. FACILITIES AND ACCREDITATIONS

### 4.1 FACILITIES

All measurement facilities used to collect the measurement data are located at

**No.10-1, Mingkeda Logistics Park, No.18, Huanguan South Rd.,  
Guan Lan Town, Baoan District, Shenzhen, China**

The sites are constructed in conformance with the requirements of ANSI C63.4:2009, ANSI C63.7 and CISPR Publication 22. All receiving equipment conforms to CISPR Publication 16-1, "Radio Interference Measuring Apparatus and Measurement Methods."

### 4.2 ACCREDITATIONS

Our laboratories are accredited and approved by the following accreditation body according to ISO/IEC 17025.

<b>USA</b>	A2LA
<b>China</b>	CNAS

The measuring facility of laboratories has been authorized or registered by the following approval agencies.

<b>USA</b>	FCC
<b>Japan</b>	VCCI(C-3478, R-3135, T-652, G-624)
<b>Canada</b>	INDUSTRY CANADA
<b>Taiwan</b>	BSMI
<b>Norway</b>	Nemko

Copies of granted accreditation certificates are available for downloading from our web site, <http://www.ccsrf.com>

### 4.3 MEASUREMENT UNCERTAINTY

Where relevant, the following measurement uncertainty levels have been estimated for tests performed on the EUT as specified in CISPR 16-4-2:

Measurement	Frequency	Uncertainty
Conducted emissions	9kHz~30MHz	+/- 3.18dB
Radiated emissions	30MHz ~ 200MHz	+/- 3.79dB
	200MHz ~1000MHz	+/- 3.62dB
	Above 1000MHz	+/- 5.04dB
Band Edges	+/-0.182 dB	

This uncertainty represents an expanded uncertainty expressed at approximately the 95% confidence level using a coverage factor of k=2.

The measured result is above (below) the specification limit by a margin less than the measurement uncertainty; it is therefore not possible to state compliance based on the 95% level of confidence. However, the result indicates that compliance (non-compliance) is more probable than non-compliance) with the specification limit.



## 5. SETUP OF EQUIPMENT UNDER TEST

### 5.1 SETUP CONFIGURATION OF EUT

See test photographs attached in Appendix 1 for the actual connections between EUT and support equipment.

### 5.2 SUPPORT EQUIPMENT

No.	Equipment	Model No.	Serial No.	FCC ID	Brand	Data Cable	Power Cord
1.	IPOD	A1285	YM908BYU3QX	N/A	ipod	N/A	N/A
2.	Notebook	2672	992T-2VG	N/A	IBM	Shielded 1.80m	Unshielded 2.50m

**Notes:**

*Grounding was established in accordance with the manufacturer's requirements and conditions for the intended use.*





## 6. FCC PART 15.247 REQUIREMENTS

### 6.1 20dB BANDWIDTH

None; for reporting purpose only.

#### MEASUREMENT EQUIPMENT USED

Name of Equipment	Manufacturer	Model	Serial Number	Last Calibration	Due Calibration
Spectrum Analyzer	Agilent	E4446A	US44300399	03/19/2012	03/19/2013

*Remark: Each piece of equipment is scheduled for calibration once a year.*

#### TEST CONFIGURATION

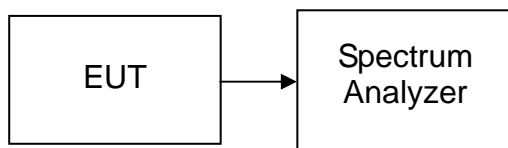

#### TEST PROCEDURE

1. Place the EUT on the table and set it in the transmitting mode.
2. Remove the antenna from the EUT, then connect a low loss RF cable from antenna port to the spectrum analyzer.
3. Set the spectrum analyzer as RBW=30kHz, VBW=30kHz, Span=3MHz, Sweep = auto.
4. Mark the peak frequency and 20dB (upper and lower) frequency.
5. Repeat until all the test channels are investigated.

#### TEST RESULTS

No non-compliance noted



Test plot ( GFSK)

20dB Bandwidth (CH Low)

Agilent

R T

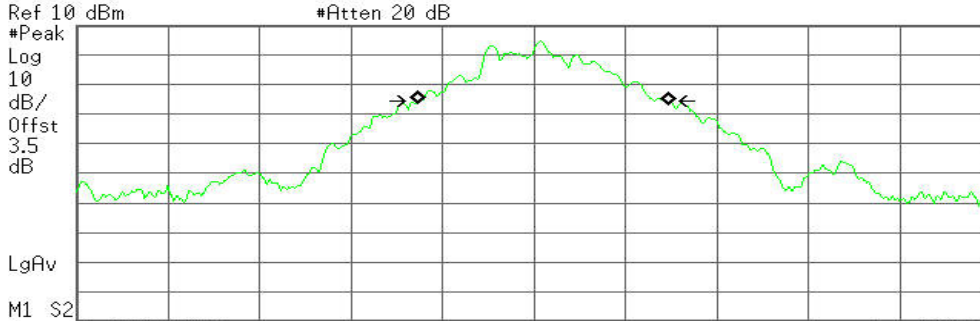

Center 2.402 000 GHz Span 3 MHz  
 #Res BW 30 kHz VBW 30 kHz Sweep 4.04 ms (601 pts)

Occupied Bandwidth  
 822.3121 kHz

Occ BW % Pwr 99.00 %  
 x dB -20.00 dB

Transmit Freq Error 29.232 kHz  
 x dB Bandwidth 795.399 kHz

20dB Bandwidth (CH Mid)

Agilent

R T

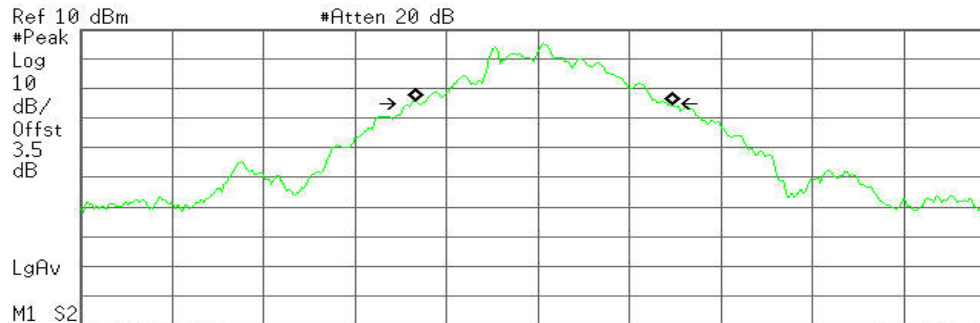

Center 2.441 000 GHz Span 3 MHz  
 #Res BW 30 kHz VBW 30 kHz Sweep 4.04 ms (601 pts)

Occupied Bandwidth  
 838.0221 kHz

Occ BW % Pwr 99.00 %  
 x dB -20.00 dB

Transmit Freq Error 20.320 kHz  
 x dB Bandwidth 834.386 kHz



### 20dB Bandwidth (CH High)

Agilent

R T

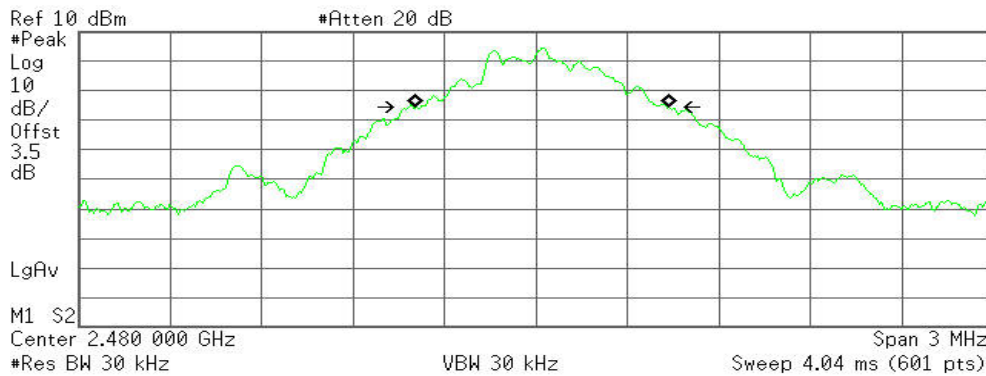

**Occupied Bandwidth**  
**829.9934 kHz**

**Occ BW % Pwr** 99.00 %  
**x dB** -20.00 dB

**Transmit Freq Error** 22.413 kHz  
**x dB Bandwidth** 850.003 kHz



Test plot ( 8DPSK)

20dB Bandwidth (CH Low)

Agilent

R T

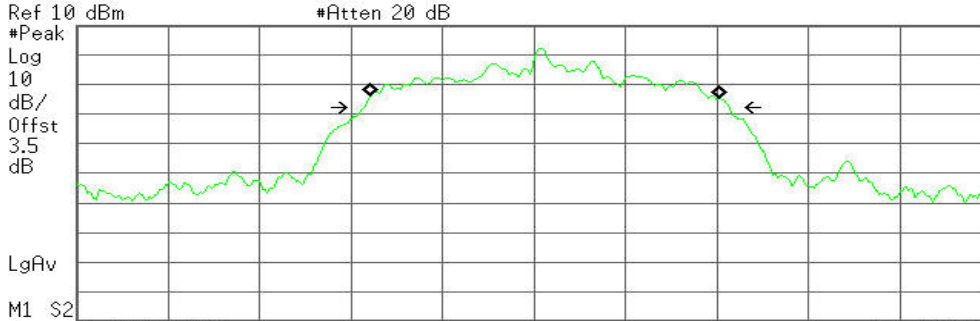

Ref 10 dBm #Atten 20 dB  
 Center 2.402 000 GHz Span 3 MHz  
 #Res BW 30 kHz VBW 30 kHz Sweep 4.04 ms (601 pts)

Occupied Bandwidth  
 1.1444 MHz

Occ BW % Pwr 99.00 %  
 x dB -20.00 dB

Transmit Freq Error 39.635 kHz  
 x dB Bandwidth 1.201 MHz

20dB Bandwidth (CH Mid)

Agilent

R T

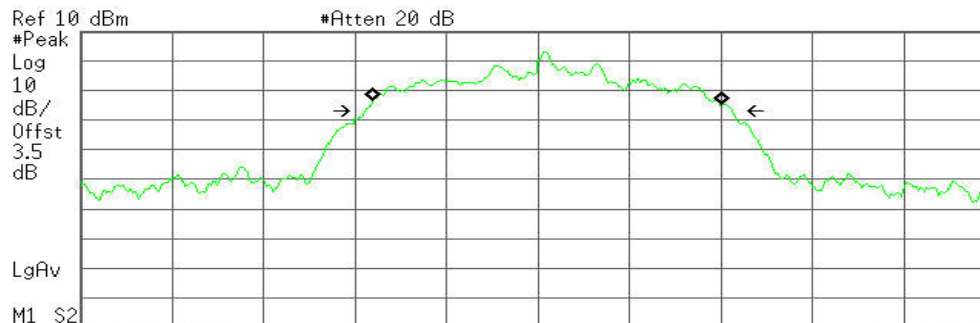

Ref 10 dBm #Atten 20 dB  
 Center 2.441 000 GHz Span 3 MHz  
 #Res BW 30 kHz VBW 30 kHz Sweep 4.04 ms (601 pts)

Occupied Bandwidth  
 1.1458 MHz

Occ BW % Pwr 99.00 %  
 x dB -20.00 dB

Transmit Freq Error 33.457 kHz  
 x dB Bandwidth 1.203 MHz



### 20dB Bandwidth (CH High)

Agilent

R T

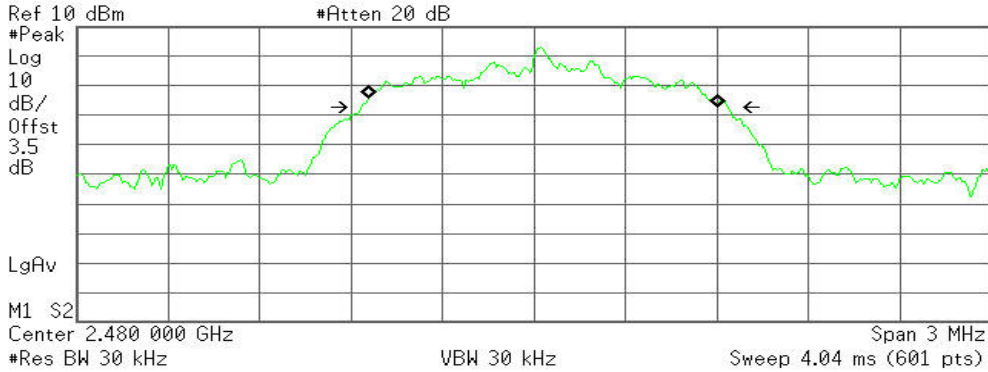

Occupied Bandwidth  
1.1462 MHz

Occ BW % Pwr 99.00 %  
x dB -20.00 dB

Transmit Freq Error 32.430 kHz  
x dB Bandwidth 1.200 MHz



## 6.2 PEAK POWER

### LIMIT

The maximum peak output power of the intentional radiator shall not exceed the following:

1. For frequency hopping systems operating in the 2400-2483.5 MHz band employing at least 75 non-overlapping hopping channels, and all frequency hopping systems in the 5725-5850 MHz band: 1 watt. For all other frequency hopping systems in the 2400-2483.5 MHz band: 0.125 watts.
2. Except as shown in paragraphs (b)(3) (i), (ii) and (iii) of this section, if transmitting antennas of directional gain greater than 6dBi are used the peak output power from the intentional radiator shall be reduced below the stated values in paragraphs (b)(1) or (b)(2) of this section, as appropriate, by the amount in dB that the directional gain of the antenna exceeds 6dBi.
3. The conducted output power limit specified in paragraph (b) of this section is based on the use of antennas with directional gains that do not exceed 6 dBi. Except as shown in paragraph (c) of this section, if transmitting antennas of directional gain greater than 6 dBi are used, the conducted output power from the intentional radiator shall be reduced below the stated values in paragraphs (b)(1), (b)(2), and (b)(3) of this section, as appropriate, by the amount in dB that the directional gain of the antenna exceeds 6 dBi.

### MEASUREMENT EQUIPMENT USED

Name of Equipment	Manufacturer	Model	Serial Number	Last Calibration	Due Calibration
Power Meter	Anritsu	ML2487A	6K00001491	03/19/2012	03/19/2013
Spectrum Analyzer	Agilent	E4446A	US44300399	03/19/2012	03/19/2013
Power Sensor	Anritsu	MA2411B	1126150	01/27/2012	01/27/2013

*Remark: Each piece of equipment is scheduled for calibration once a year.*

### Test Configuration

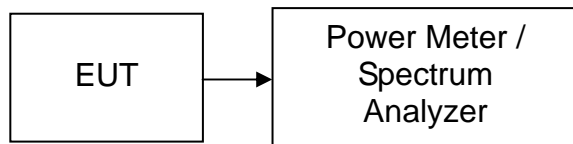

### TEST PROCEDURE

The transmitter output is connected to the RF Power Meter. The RF Power Meter is set to the peak power detection.



**TEST RESULTS**

*No non-compliance noted*

**Test Data**

**GFSK**

Channel	Frequency (MHz)	Reading Power (dBm)	Factor (dB)	Output Power (dBm)	Output Power (W)	Limit (W)	Result
Low	2402	-3.79	3.50	-0.29	0.00094	1	PASS
Mid	2441	-3.27	3.50	0.23	0.00105		PASS
High	2480	-3.76	3.50	-0.26	0.00094		PASS

**8DPSK**

Channel	Frequency (MHz)	Reading Power (dBm)	Factor (dB)	Output Power (dBm)	Output Power (W)	Limit (W)	Result
Low	2402	-6.02	3.50	-2.52	0.00056	1	PASS
Mid	2441	-5.27	3.50	-1.77	0.00067		PASS
High	2480	-5.53	3.50	-2.03	0.00063		PASS



### 6.3 PEAK POWER SPECTRAL DENSITY

#### LIMIT

1. For direct sequence systems, the peak power spectral density conducted from the intentional radiator to the antenna shall not be greater than 8dBm in any 3kHz band during any time interval of continuous transmission.
2. The direct sequence operating of the hybrid system, with the frequency hopping operation turned off, shall comply with the power density requirements of paragraph (d) of this section.

#### MEASUREMENT EQUIPMENT USED

Name of Equipment	Manufacturer	Model	Serial Number	Last Calibration	Due Calibration
Spectrum Analyzer	Agilent	E4446A	US44300399	03/19/2012	03/19/2013

*Remark: Each piece of equipment is scheduled for calibration once a year.*

#### Test Configuration

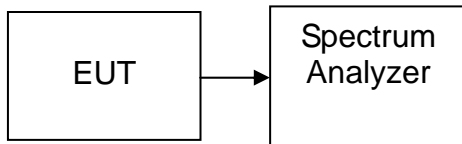

#### TEST PROCEDURE

1. Place the EUT on the table and set it in transmitting mode.
2. Remove the antenna from the EUT and then connect a low loss RF cable from the antenna port to the spectrum analyzer.
3. Set the spectrum analyzer as RBW = 3kHz, VBW = 10kHz, Span = 300kHz, Sweep=100s
4. Record the max. reading.
5. Repeat the above procedure until the measurements for all frequencies are completed.

#### TEST RESULTS

*Not applicable. Since EUT is the Bluetooth device.*





### 6.4 BAND EDGES MEASUREMENT

#### LIMIT

According to §15.247(c), in any 100 kHz bandwidth outside the frequency bands in which the spread spectrum intentional radiator is operating, the radio frequency power that is produced by the intentional radiator shall be at least 20dB below that in the 100kHz bandwidth within the band that contains the highest level of the desired power. In addition, radiated emissions which fall in the restricted bands, as defined in §15.205(a), must also comply with the radiated emission limits specified in 15.209(a).

#### MEASUREMENT EQUIPMENT USED

Radiated Emission Test Site 966(2)					
Name of Equipment	Manufacturer	Model Number	Serial Number	Last Calibration	Due Calibration
PSA Series Spectrum Analyzer	Agilent	E4446A	US44300399	03/19/2012	03/19/2013
ESCI EMI TEST RECEIVER.ESCI	ROHDE&SCHWARZ	ESCI	100783	03/17/2012	03/17/2013
Amplifier	MITEQ	AM-1604-3000	1123808	03/18/2012	03/18/2013
Turn Table	EMCO	2081-1.21	N/A	N.C.R	N.C.R
Controller	CT	N/A	N/A	N.C.R	N.C.R
High Noise Amplifier	Agilent	8449B	3008A01838	03/18/2012	03/18/2013
Bilog Antenna	SCHAFFNER	CBL6143	5082	03/17/2012	03/17/2013
Horn Antenna	SCHWARZBECK	BBHA9120	D286	03/17/2012	03/17/2013
Loop Antenna	A、R、A	PLA-1030/B	1029	03/23/2012	03/23/2013
Temp. / Humidity Meter	VICTOR	VC230	N/A	03/19/2012	03/19/2013
Antenna Tower	SUNOL	TLT2	N/A	N.C.R	N.C.R
Test S/W	FARAD	LZ-RF / CCS-SZ-3A2			

#### Test Configuration

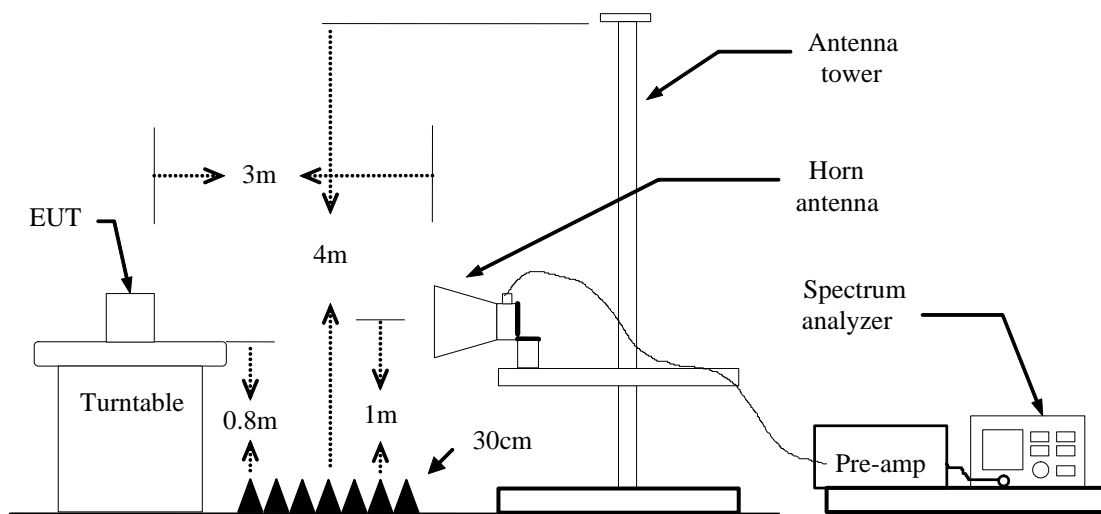



## **TEST PROCEDURE**

1. The EUT is placed on a turntable, which is 0.8m above the ground plane.
2. The turntable shall be rotated for 360 degrees to determine the position of maximum emission level.
3. EUT is set 3m away from the receiving antenna, which is varied from 1m to 4m to find out the highest emission.
4. Set the spectrum analyzer in the following setting in order to capture the lower and upper band-edges of the emission:
  - (a) PEAK: RBW=VBW=1MHz / Sweep=AUTO
  - (b) AVERAGE: RBW=1MHz / VBW=510Hz / Sweep=AUTO
5. Repeat the procedures until all the PEAK and AVERAGE versus POLARIZATION are measured.

## **TEST RESULTS**

Refer to attach spectrum analyzer data chart.



Test Data ( GFSK )

Band Edges (CH-Low)

Detector mode: Peak

Polarity: Vertical

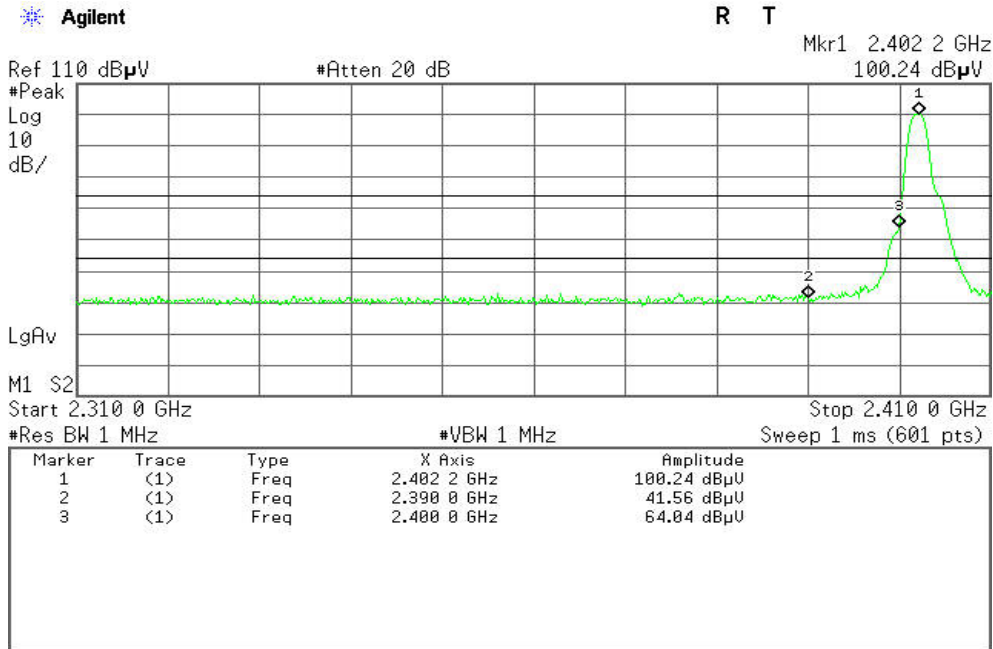

Detector mode: Average

Polarity: Vertical

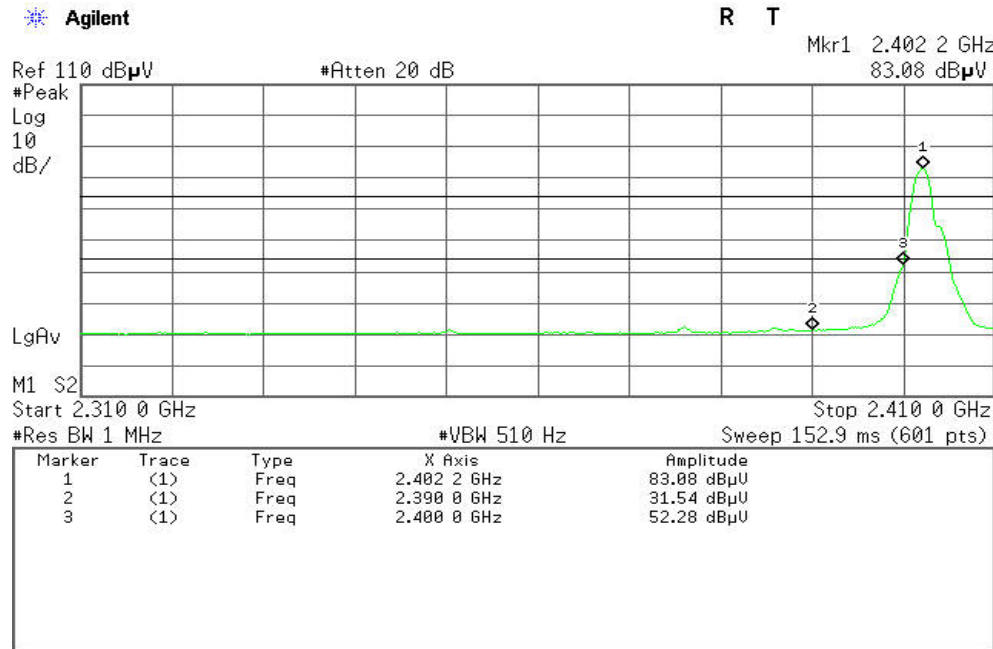



Detector mode: Peak

Polarity: Horizontal

Agilent

R T

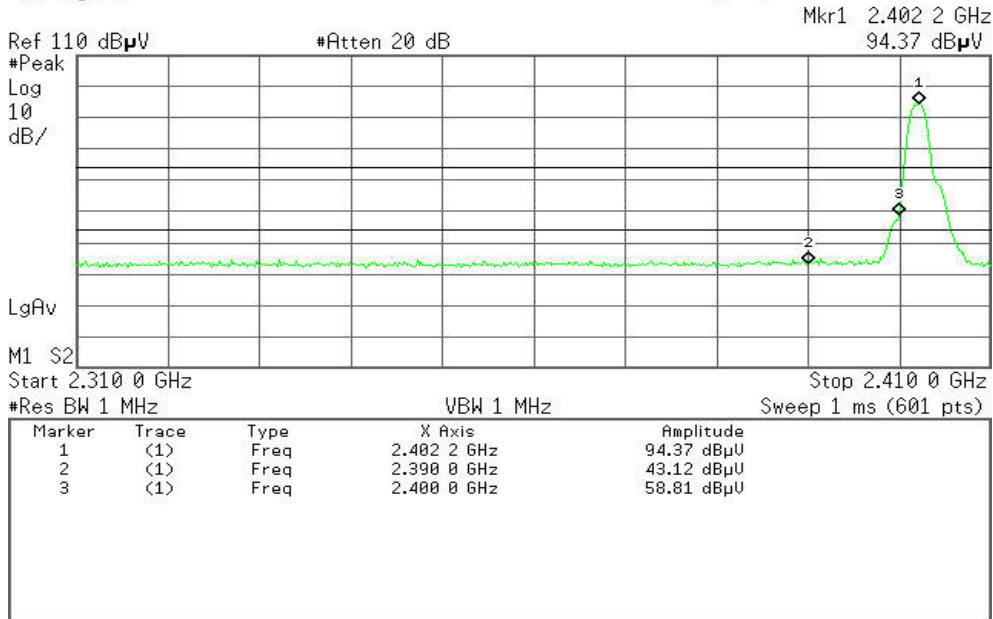

Detector mode: Average

Polarity: Horizontal

Agilent

R T

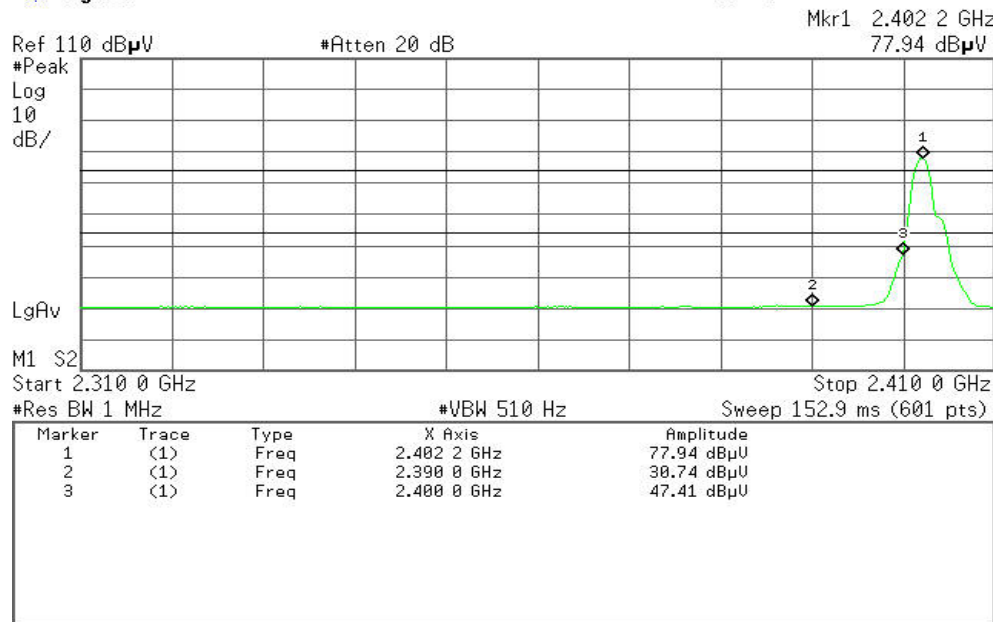



Band Edges (CH-High)

Detector mode: Peak

Polarity: Vertical

Agilent

R T

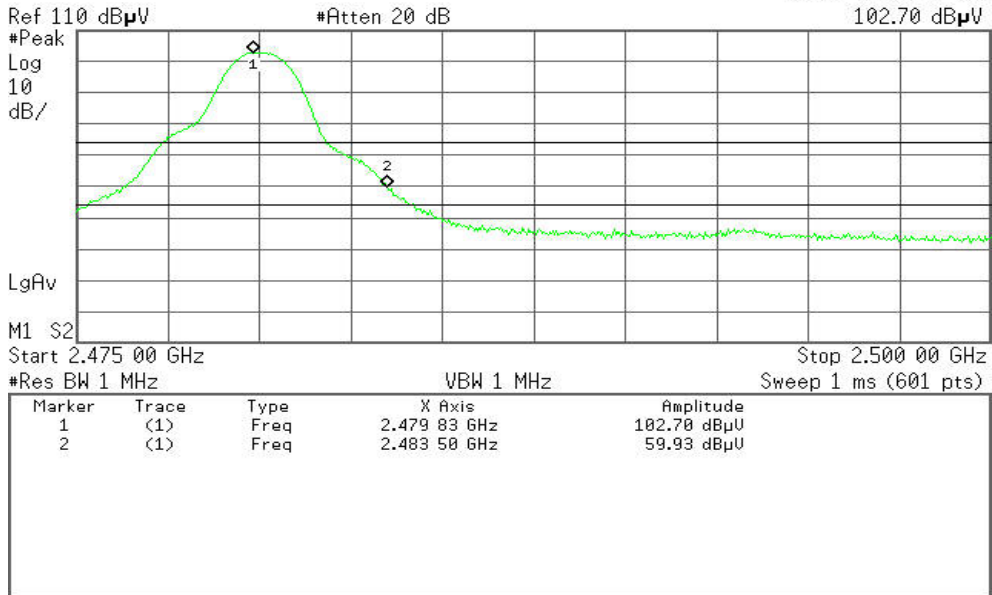

Detector mode: Average

Polarity: Vertical

Agilent

R T

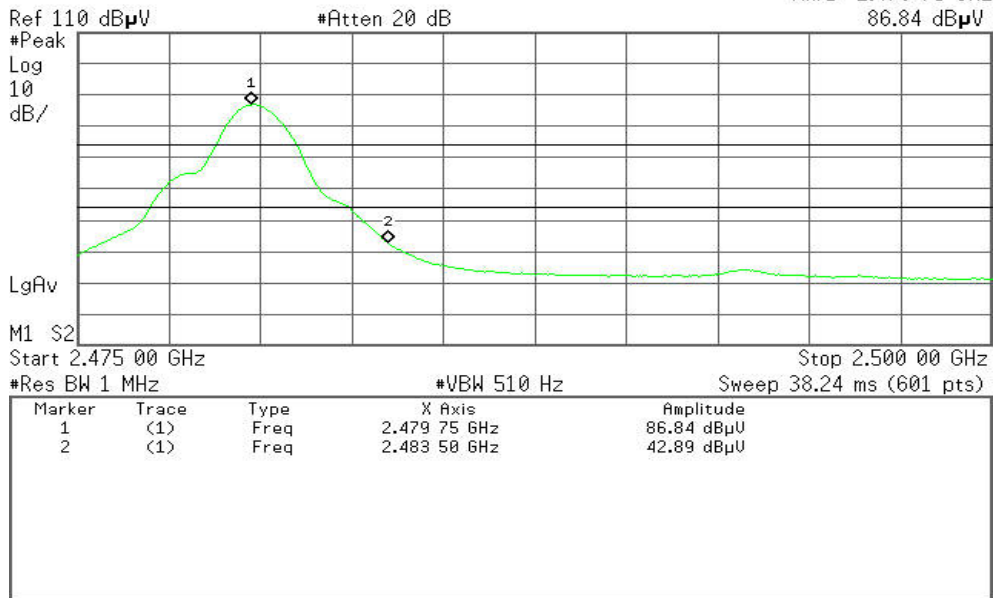



Detector mode: Peak

Polarity: Horizontal

Agilent

R T

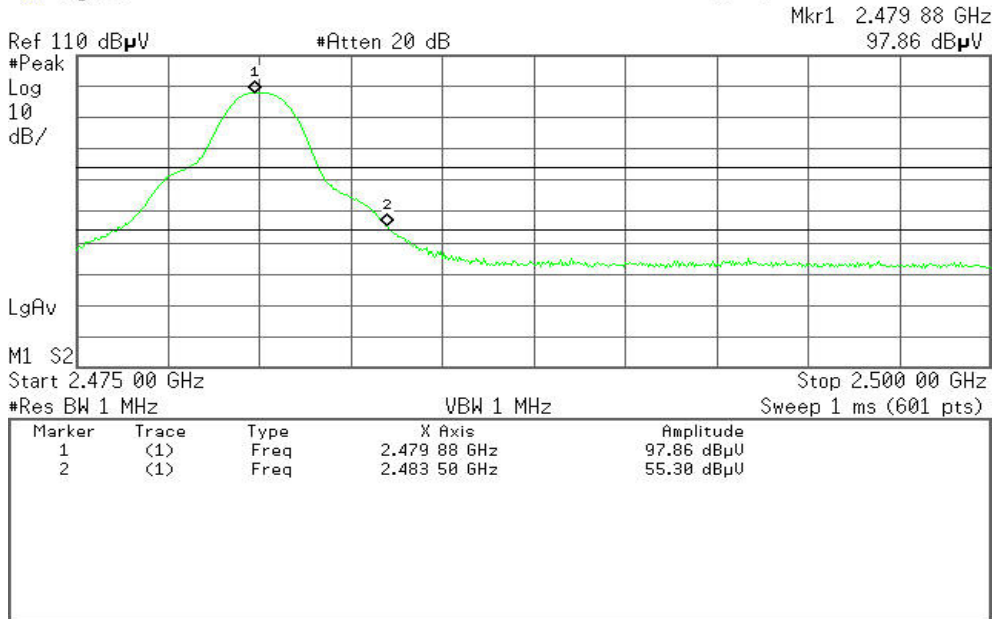

Detector mode: Average

Polarity: Horizontal

Agilent

R T

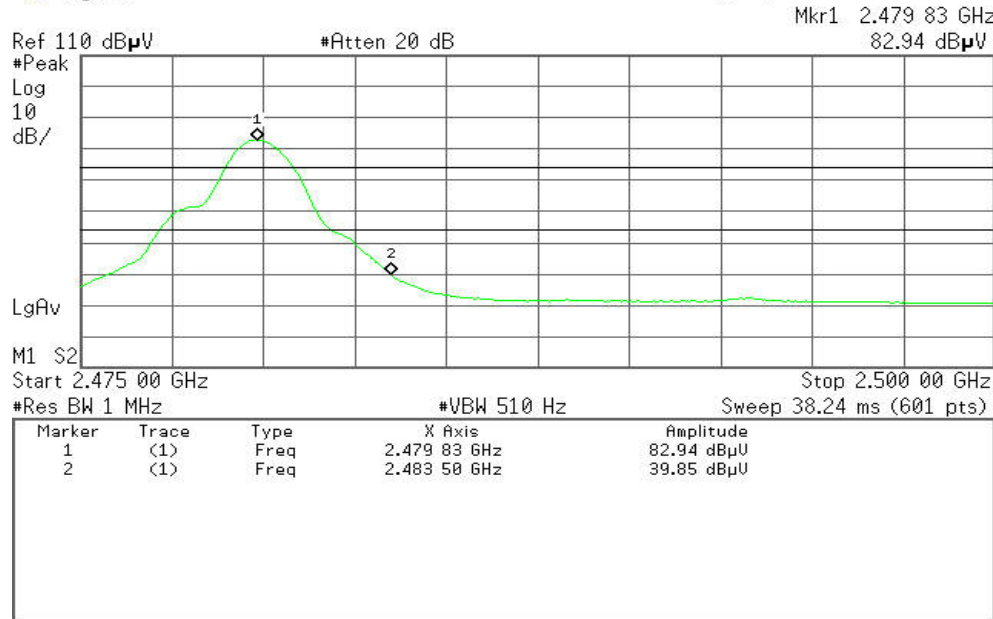



Test Data ( 8DPSK )

Band Edges (CH-Low)

Detector mode: Peak

Polarity: Vertical

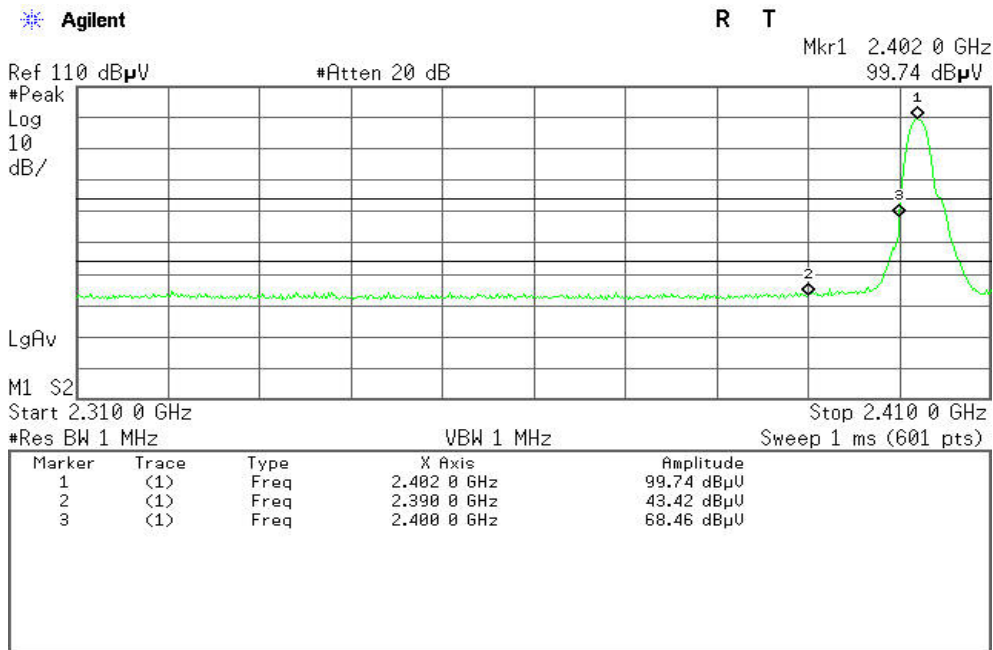

Detector mode: Average

Polarity: Vertical

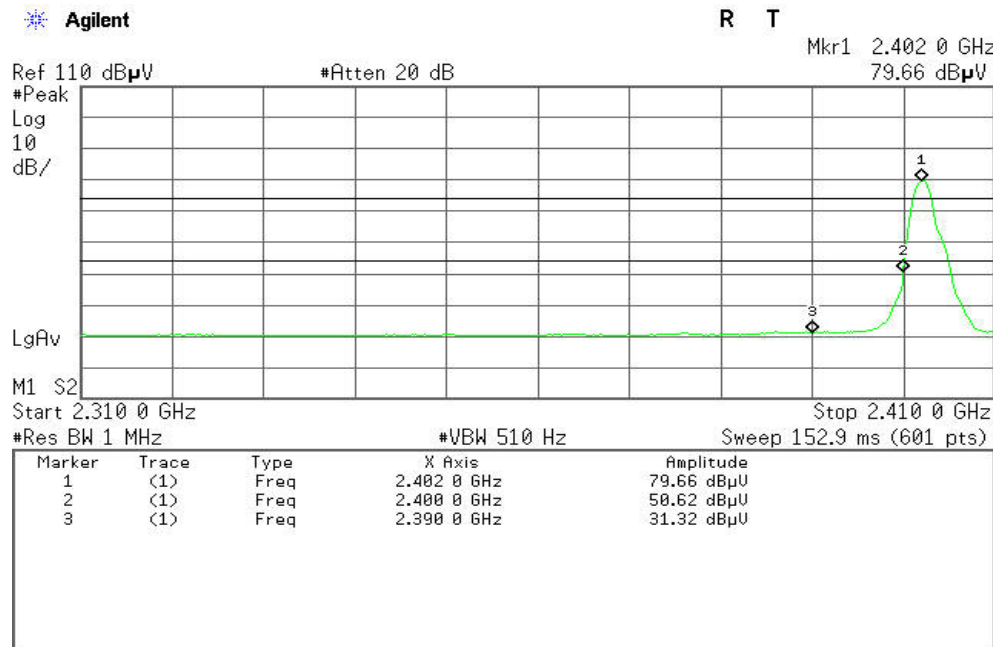



Detector mode: Peak

Polarity: Horizontal

Agilent

R T

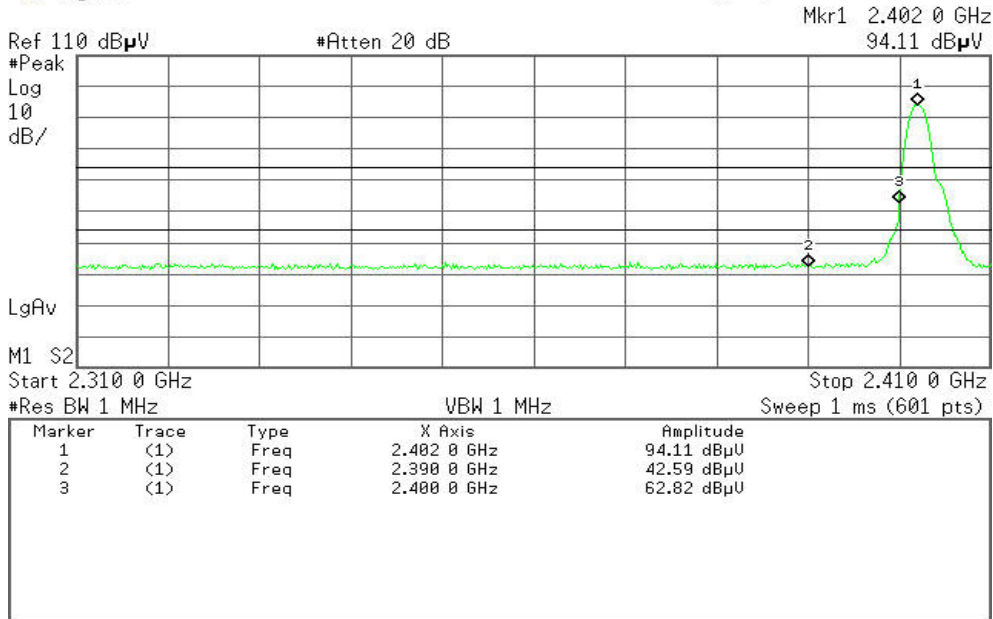

Detector mode: Average

Polarity: Horizontal

Agilent

R T

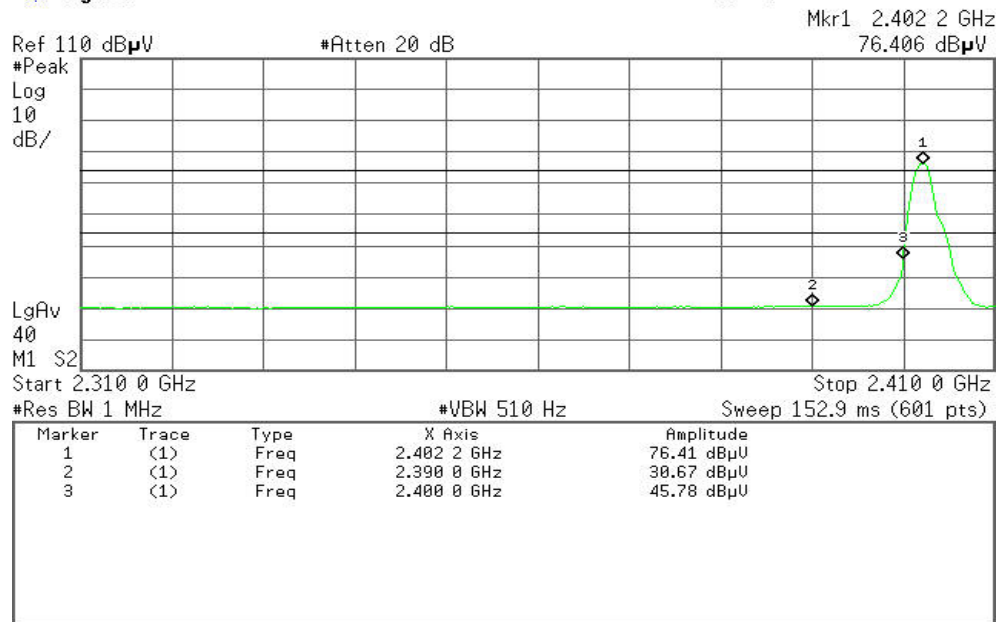





Band Edges (CH-High)

Detector mode: Peak

Polarity: Vertical

Agilent

R T

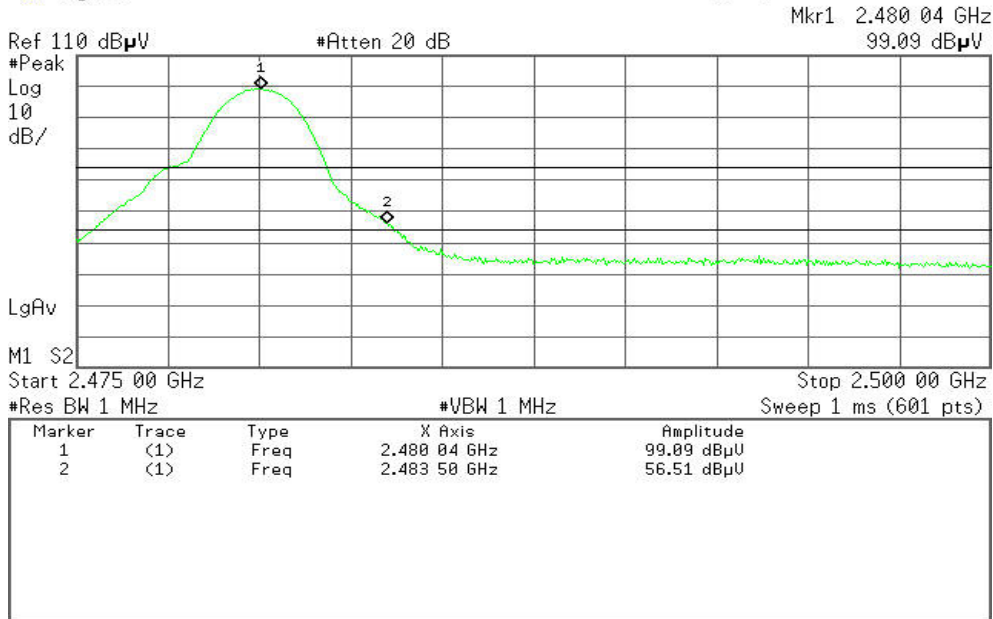

Detector mode: Average

Polarity: Vertical

Agilent

R T

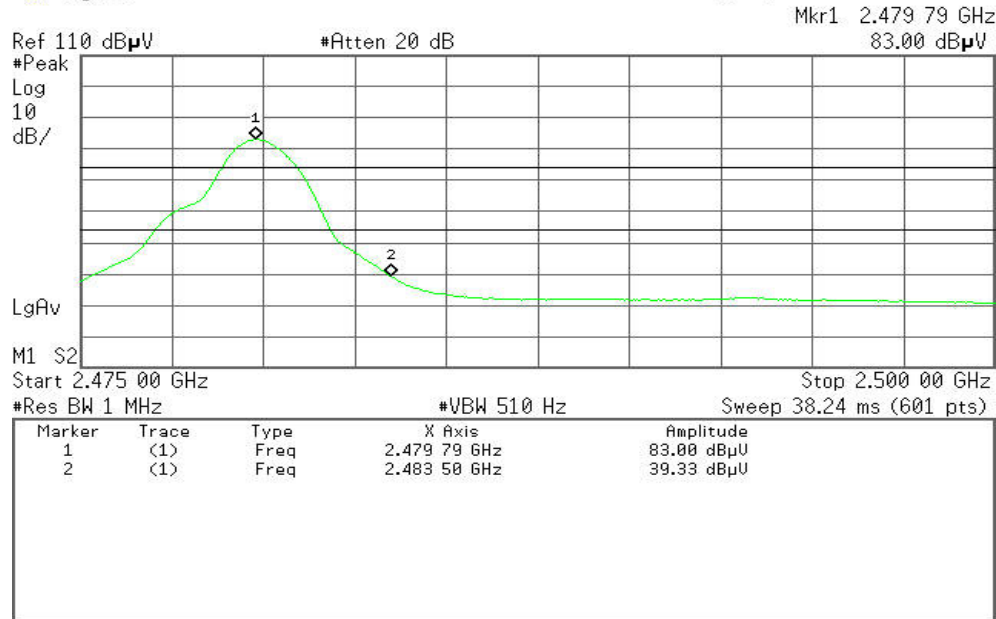



Detector mode: Peak

Polarity: Horizontal

Agilent

R T

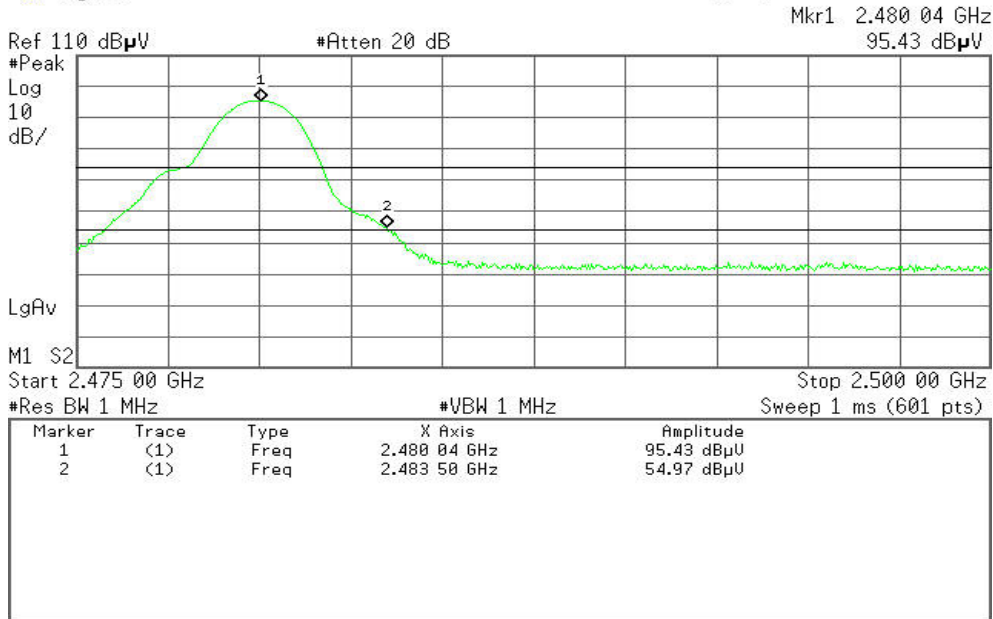

Detector mode: Average

Polarity: Horizontal

Agilent

R T

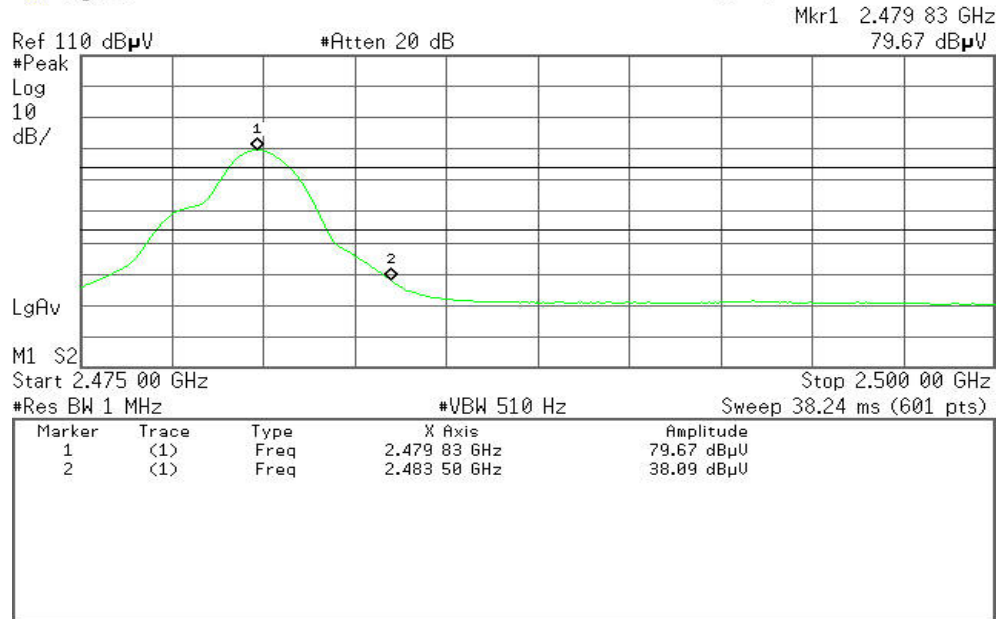



### 6.5 FREQUENCY SEPARATION

#### LIMIT

According to §15.247(a)(1), Frequency hopping systems shall have hopping channel carrier frequencies separated by a minimum of 25 kHz or the 20 dB bandwidth of the hopping channel, whichever is greater. Alternatively, frequency hopping systems operating in the 2400-2483.5 MHz band may have hopping channel carrier frequencies that are separated by 25 kHz or two-thirds of the 20 dB bandwidth of the hopping channel, whichever is greater, provided the systems operate with an output power no greater than 125 mW.

#### MEASUREMENT EQUIPMENT USED

Name of Equipment	Manufacturer	Model	Serial Number	Last Calibration	Due Calibration
Spectrum Analyzer	Agilent	E4446A	US44300399	03/19/2012	03/19/2013

*Remark: Each piece of equipment is scheduled for calibration once a year.*

#### Test Configuration

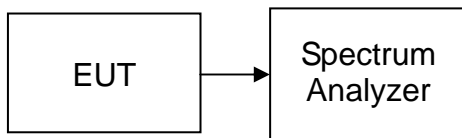

#### TEST PROCEDURE

1. Place the EUT on the table and set it in transmitting mode.
2. Remove the antenna from the EUT and then connect a low loss RF cable from the antenna port to the spectrum analyzer.
3. Set center frequency of spectrum analyzer = middle of hopping channel.
4. Set the spectrum analyzer as RBW=30kHz, VBW=30kHz, Adjust Span to 4 MHz, Sweep = auto.
5. Max hold. Mark 3 Peaks of hopping channel and record the 3 peaks frequency.

#### TEST RESULTS

*No non-compliance noted*

##### Test Data

##### GFSK

Channel Separation (MHz)	Two-thirds of the 20 dB Bandwidth (kHz)	Channel Separation Limit	Result
1.000	566.669	> Two-thirds of the 20 dB Bandwidth	Pass

##### 8DPSK

Channel Separation (MHz)	Two-thirds of the 20 dB Bandwidth (kHz)	Channel Separation Limit	Result
1.000	802.000	> Two-thirds of the 20 dB Bandwidth	Pass



**GFSK**

**Test Plot**

**Measurement of Channel Separation**

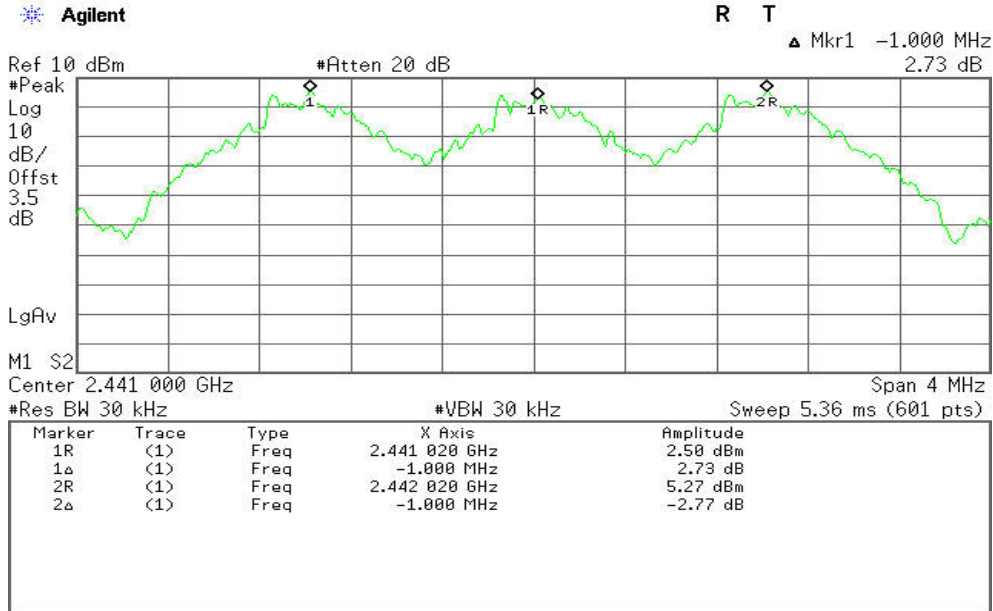

**20 dB bandwidth(CH High)**

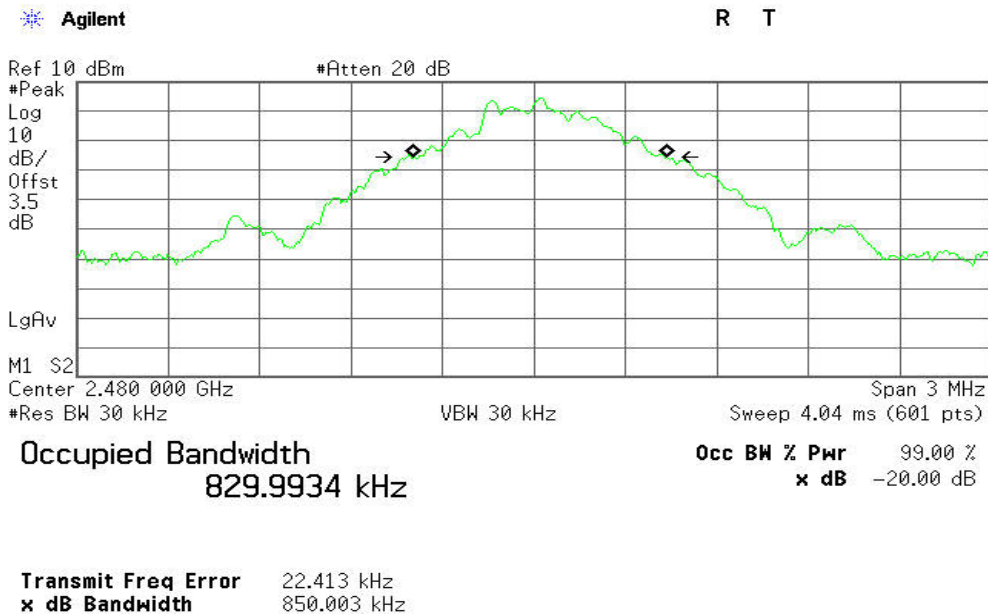



8DPSK

Test Plot

Measurement of Channel Separation

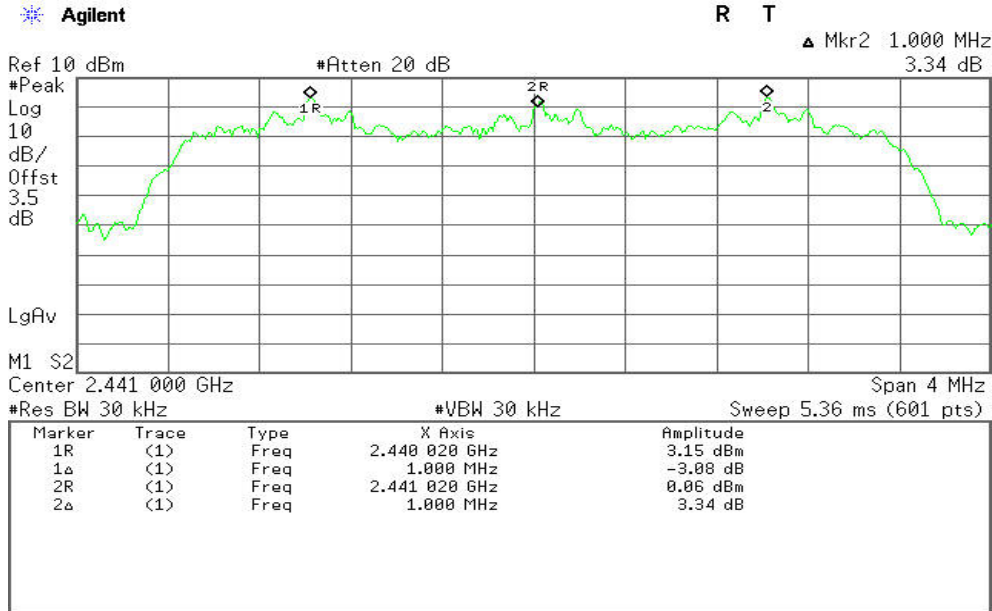

20 dB bandwidth(CH Mid)

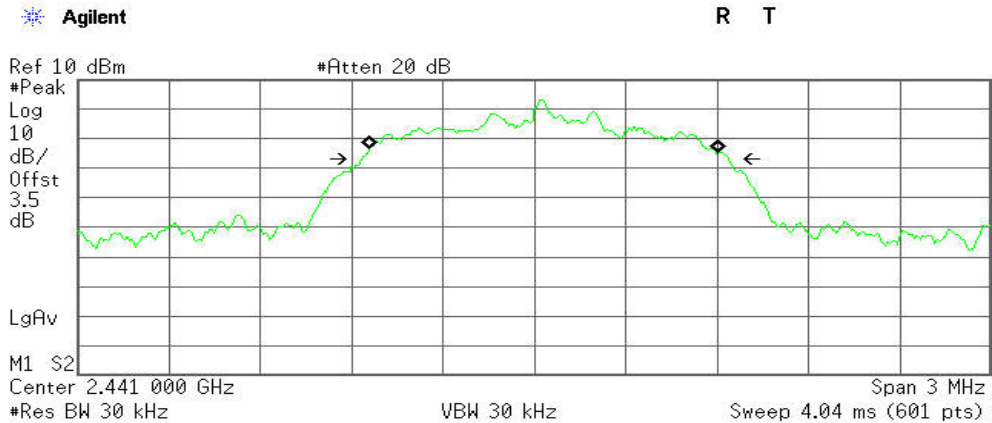

Occupied Bandwidth  
1.1458 MHz

Occ BW % Pwr 99.00 %  
x dB -20.00 dB

Transmit Freq Error 33.457 kHz  
x dB Bandwidth 1.203 MHz



### 6.6 NUMBER OF HOPPING FREQUENCY

#### LIMIT

According to §15.247(a)(1)(ii), Frequency hopping systems operating in the 2400MHz-2483.5 MHz bands shall use at least 15 hopping frequencies.

#### MEASUREMENT EQUIPMENT USED

Name of Equipment	Manufacturer	Model	Serial Number	Last Calibration	Due Calibration
Spectrum Analyzer	Agilent	E4446A	US44300399	03/19/2012	03/19/2013

*Remark: Each piece of equipment is scheduled for calibration once a year.*

#### Test Configuration

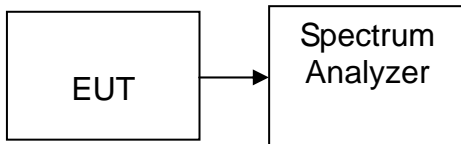

#### TEST PROCEDURE

1. Place the EUT on the table and set it in transmitting mode.
2. Remove the antenna from the EUT and then connect a low loss RF cable from the antenna port to the spectrum analyzer.
3. Set spectrum analyzer Start=2400MHz, Stop = 2441.5MHz, Sweep = 1ms and Start=2441.5MHz, Stop = 2483.5MHz, Sweep = 1ms.
4. Set the spectrum analyzer as RBW, VBW=300kHz,
5. Max hold, view and count how many channel in the band.

#### TEST RESULTS

*No non-compliance noted*

#### Test Data

Result (No. of CH)	Limit (No. of CH)	Result
79	>15	PASS



**Test Plot ( GFSK )**

**Channel Number**

**2.400 GHz – 2.4415 GHz**

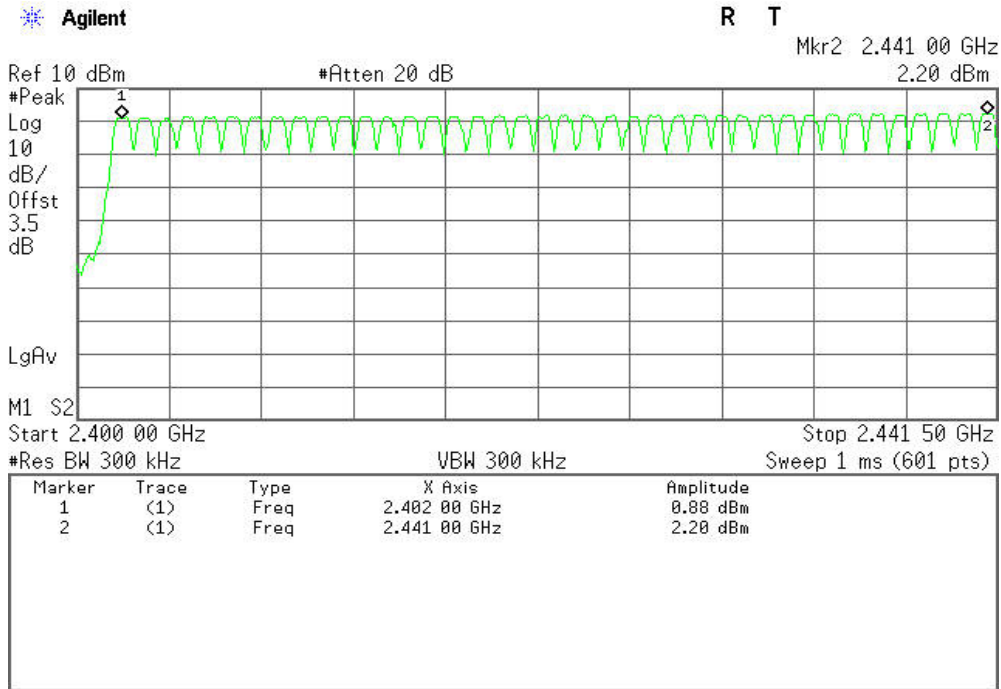

**2.4415 GHz –2.4835 GHz**

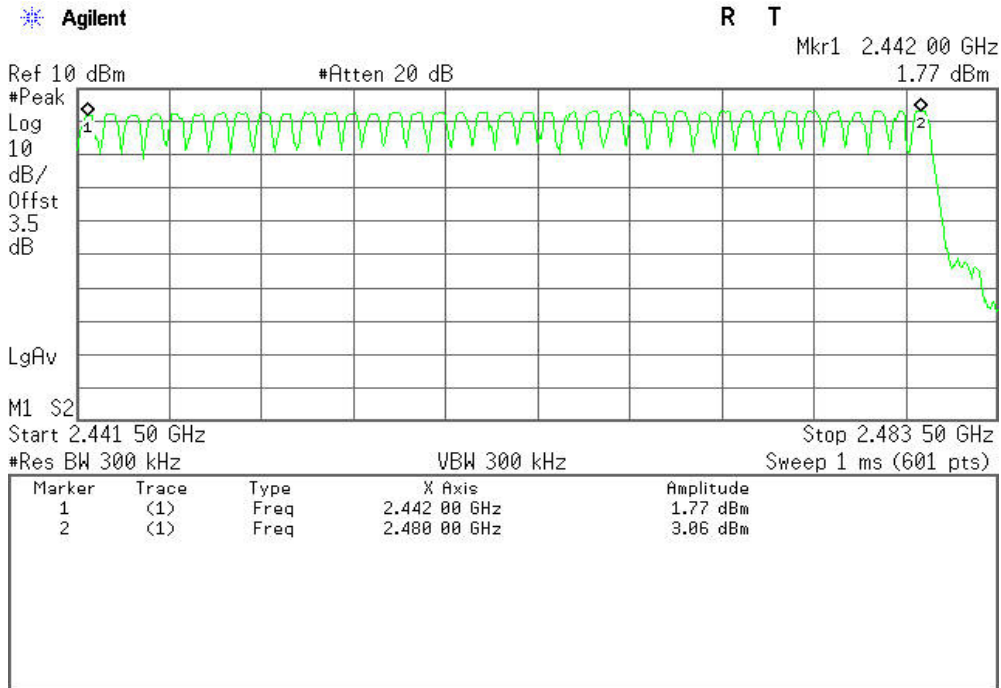



**Test Plot (8DPSK )**

**Channel Number**

**2.400 GHz – 2.4415 GHz**

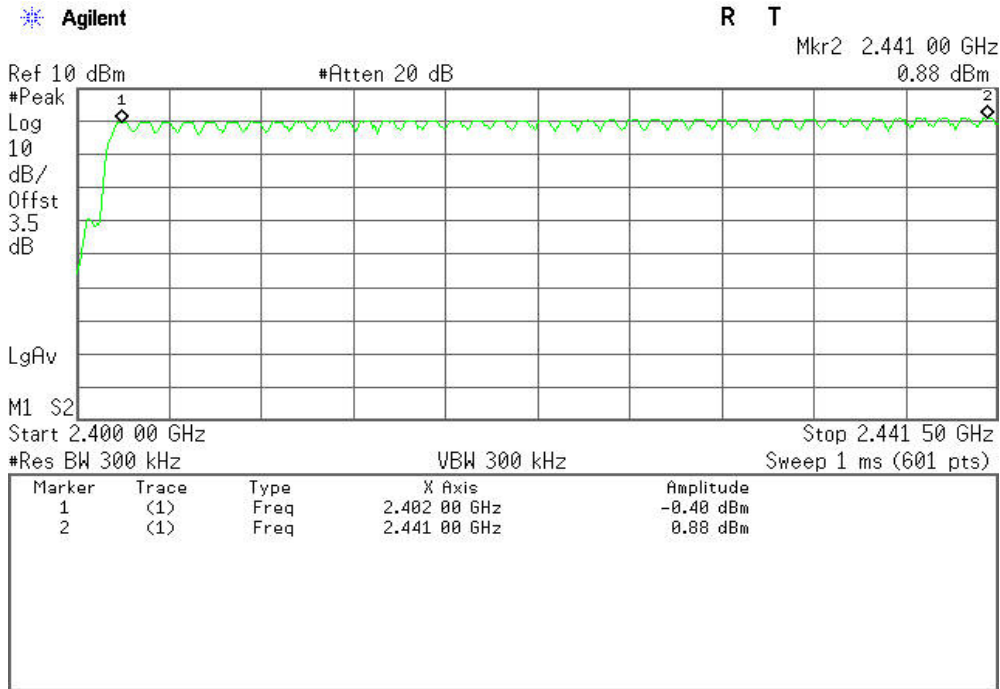

**2.4415 GHz –2.4835 GHz**

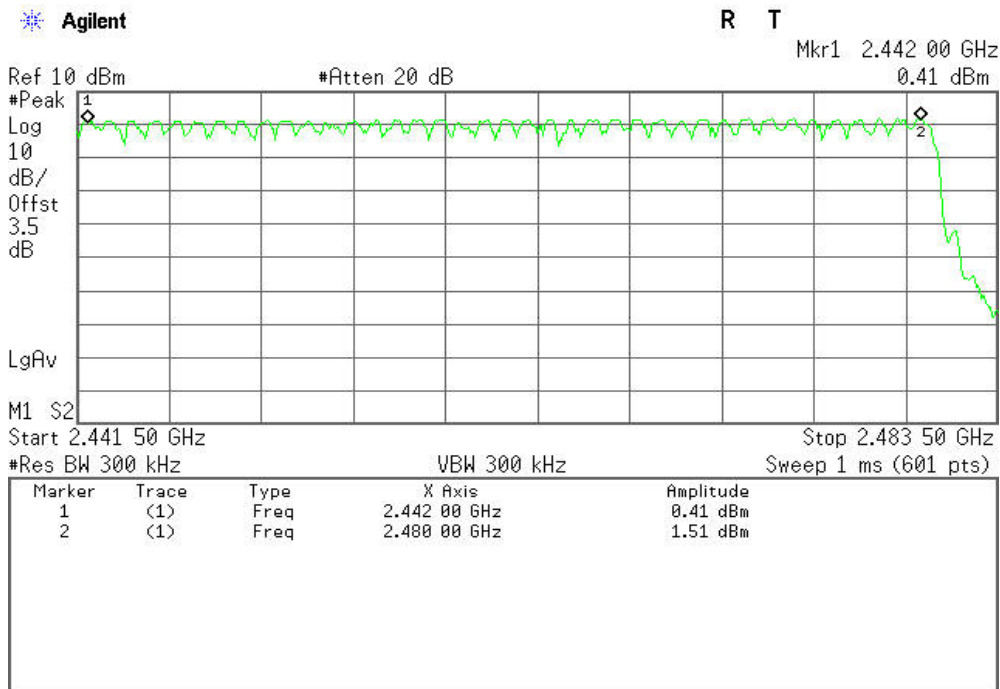





## 6.7 TIME OF OCCUPANCY (DWELL TIME)

### LIMIT

According to §15.247(a)(1)(iii), Frequency hopping systems operating in the 2400MHz-2483.5 MHz bands. The average time of occupancy on any channels shall not greater than 0.4 s within a period 0.4 s multiplied by the number of hopping channels employed.

### MEASUREMENT EQUIPMENT USED

Name of Equipment	Manufacturer	Model	Serial Number	Last Calibration	Due Calibration
Spectrum Analyzer	Agilent	E4446A	US44300399	03/19/2012	03/19/2013

*Remark: Each piece of equipment is scheduled for calibration once a year.*

### Test Configuration

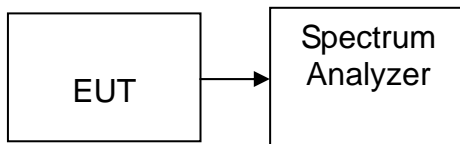

### TEST PROCEDURE

1. Place the EUT on the table and set it in transmitting mode.
2. Remove the antenna from the EUT and then connect a low loss RF cable from the antenna port to the spectrum analyzer.
3. Set center frequency of spectrum analyzer = operating frequency.
4. Set the spectrum analyzer as RBW, VBW=1MHz, Span = 0Hz, Sweep = auto.
5. Repeat above procedures until all frequency measured were complete.



**TEST RESULTS**

*No non-compliance noted*

**Test Data**

**GFSK**

**DH 1**

CH Mid:  $0.510 * (1600/2)/79 * 31.6 = 163.200$  (ms)

CH	Pulse Time (ms)	Total of Dwell (ms)	Period Time (s)	Limit (ms)	Result
Mid	0.510	163.200	31.60	400.00	PASS

**DH 3**

CH Mid:  $1.765 * (1600/4)/79 * 31.6 = 282.400$  (ms)

CH	Pulse Time (ms)	Total of Dwell (ms)	Period Time (s)	Limit (ms)	Result
Mid	1.765	282.400	31.60	400.00	PASS

**DH 5**

CH Mid:  $3.017 * (1600/6)/79 * 31.6 = 321.813$  (ms)

CH	Pulse Time (ms)	Total of Dwell (ms)	Period Time (s)	Limit (ms)	Result
Mid	3.017	321.813	31.60	400.00	PASS



**Test Data**

**8DPSK**

**DH 1**

CH Mid:  $0.520 * (1600/2)/79 * 31.6 = 166.400$  (ms)

CH	Pulse Time (ms)	Total of Dwell (ms)	Period Time (s)	Limit (ms)	Result
Mid	0.520	166.400	31.60	400.00	PASS

**DH 3**

CH Mid:  $1.770 * (1600/4)/79 * 31.6 = 283.200$  (ms)

CH	Pulse Time (ms)	Total of Dwell (ms)	Period Time (s)	Limit (ms)	Result
Mid	1.770	283.200	31.60	400.00	PASS

**DH 5**

CH Mid:  $3.025 * (1600/6)/79 * 31.6 = 322.667$  (ms)

CH	Pulse Time (ms)	Total of Dwell (ms)	Period Time (s)	Limit (ms)	Result
Mid	3.025	322.667	31.60	400.00	PASS



**Test Plot**

**GFSK**

**DH 1**

**(CH Mid)**

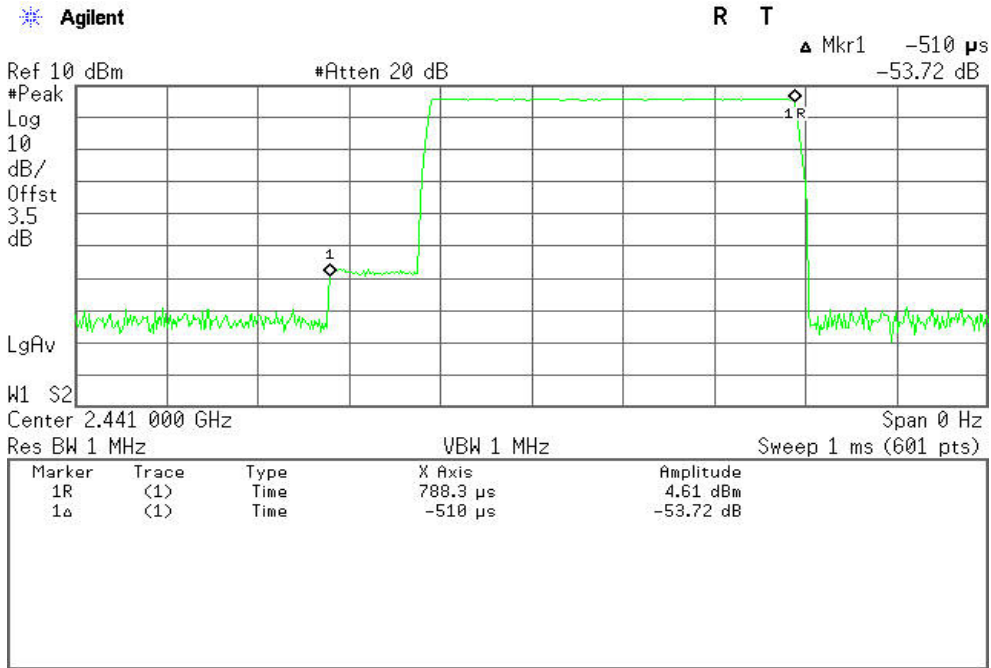

**DH 3**

**(CH Mid)**

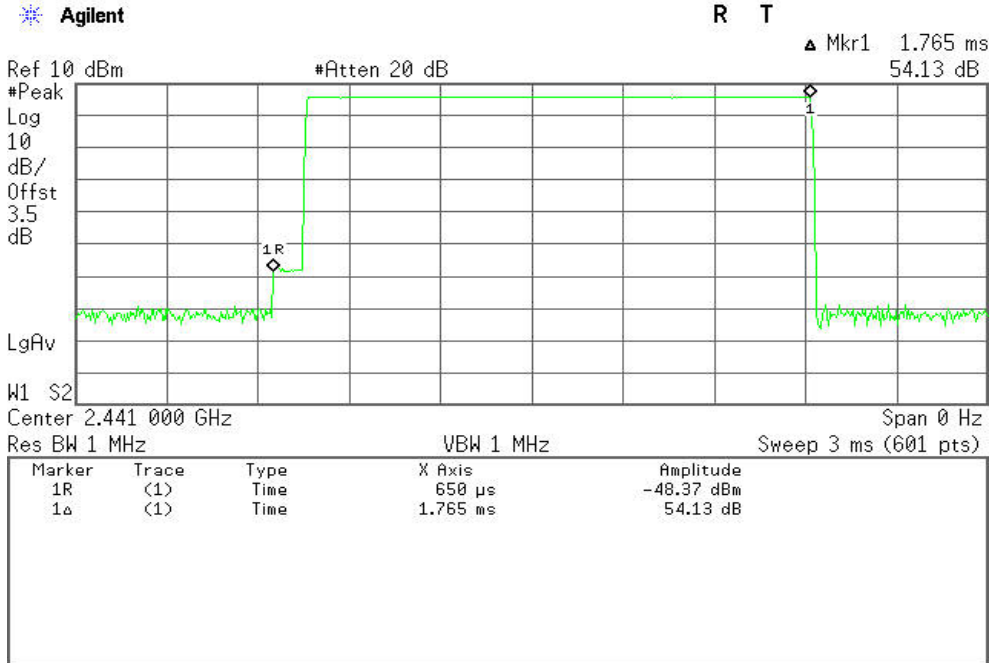



**DH 5**

**(CH Mid)**

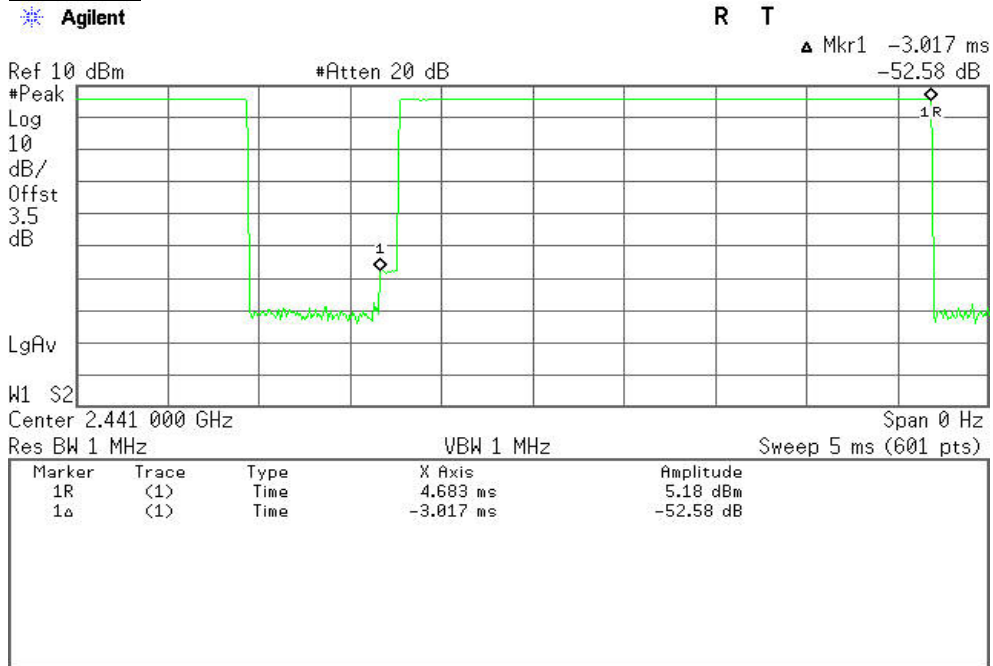



**Test Plot**  
**8DPSK**

**DH 1**

**(CH Mid)**

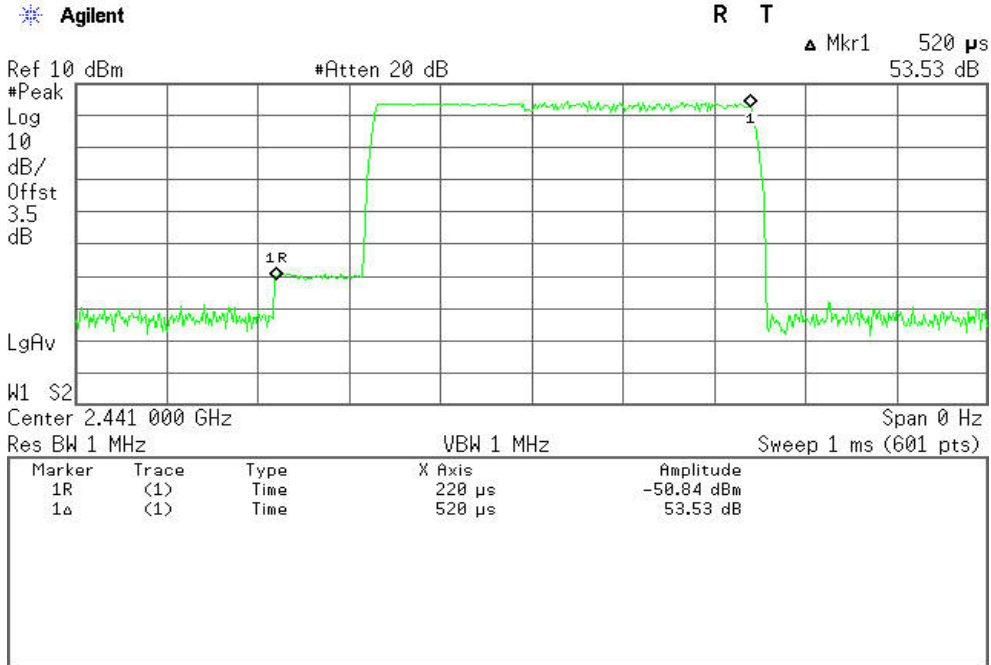

**DH 3**

**(CH Mid)**

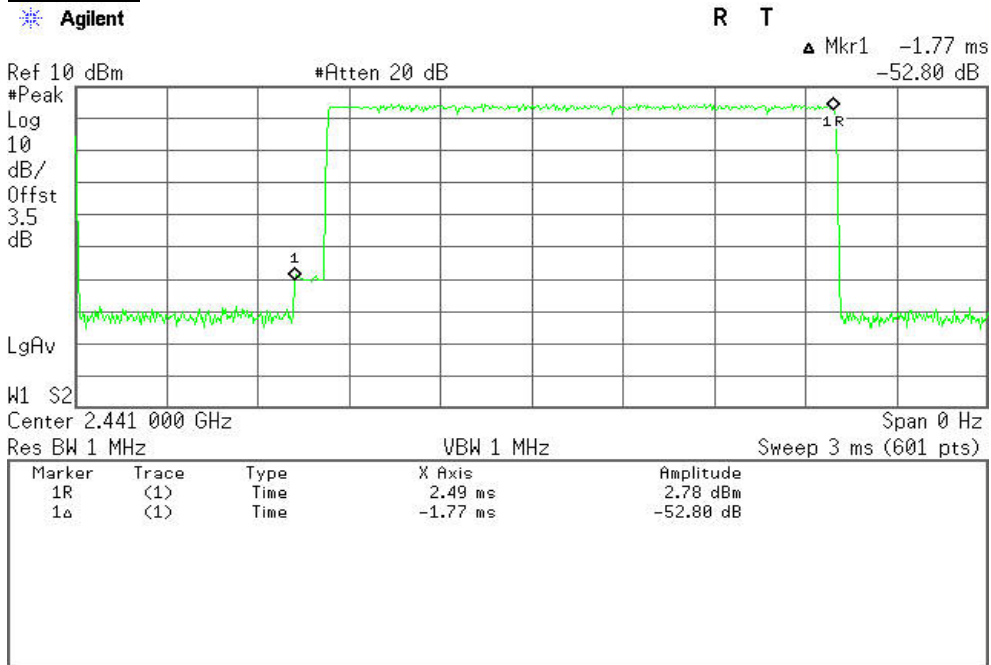



**DH 5**

**(CH Mid)**

Agilent

R T

Mkr1 3.025 ms  
53.36 dB

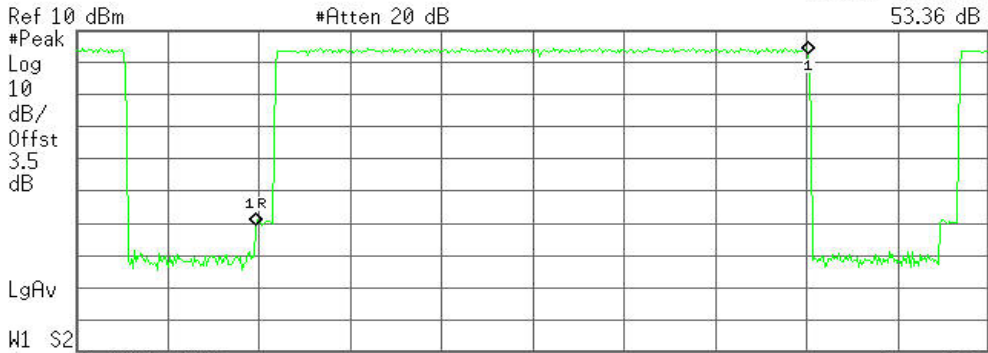

Ref 10 dBm #Atten 20 dB  
Log 10 dB/Offst 3.5 dB  
LgAv  
W1 S2  
Center 2.441 000 GHz Span 0 Hz  
Res BW 1 MHz VBW 1 MHz Sweep 5 ms (601 pts)

Marker	Trace	Type	X Axis	Amplitude
1R	(1)	Time	983.3 μs	-58.56 dBm
1a	(1)	Time	3.025 ms	53.36 dB



## 6.8 SPURIOUS EMISSIONS

### 6.8.1. Conducted Measurement

#### LIMIT

In any 100 kHz bandwidth outside the frequency band in which the spread spectrum or digitally modulated intentional radiator is operating, the radio frequency power that is produced by the intentional radiator shall be at least 20 dB below that in the 100 kHz bandwidth within the band that contains the highest level of the desired power, based on either an RF conducted or a radiated measurement. Attenuation below the general limits specified in Section 15.209(a) is not required. In addition, radiated emissions which fall in the restricted bands, as defined in Section 15.205(a), must also comply with the radiated emission limits specified in Section 15.209(a) (see Section 15.205(c)).

#### MEASUREMENT EQUIPMENT USED

Name of Equipment	Manufacturer	Model	Serial Number	Last Calibration	Due Calibration
Spectrum Analyzer	Agilent	E4446A	US44300399	03/19/2012	03/19/2013

*Remark: Each piece of equipment is scheduled for calibration once a year.*

#### Test Configuration

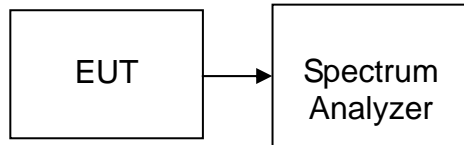

#### TEST PROCEDURE

Conducted RF measurements of the transmitter output were made to confirm that the EUT antenna port conducted emissions meet the specified limit and to identify any spurious signals that require further investigation or measurements on the radiated emissions site.

The transmitter output is connected to the spectrum analyzer. The resolution bandwidth is set to 100 kHz. The video bandwidth is set to 100 kHz.

Measurements are made over the 30MHz to 26GHz range with the transmitter set to the lowest, middle, and highest channels.

#### TEST RESULTS

*No non-compliance noted*





**Test Plot ( GFSK )**

**CH Low**

**30MHz ~2.9GHz**

Agilent

R T

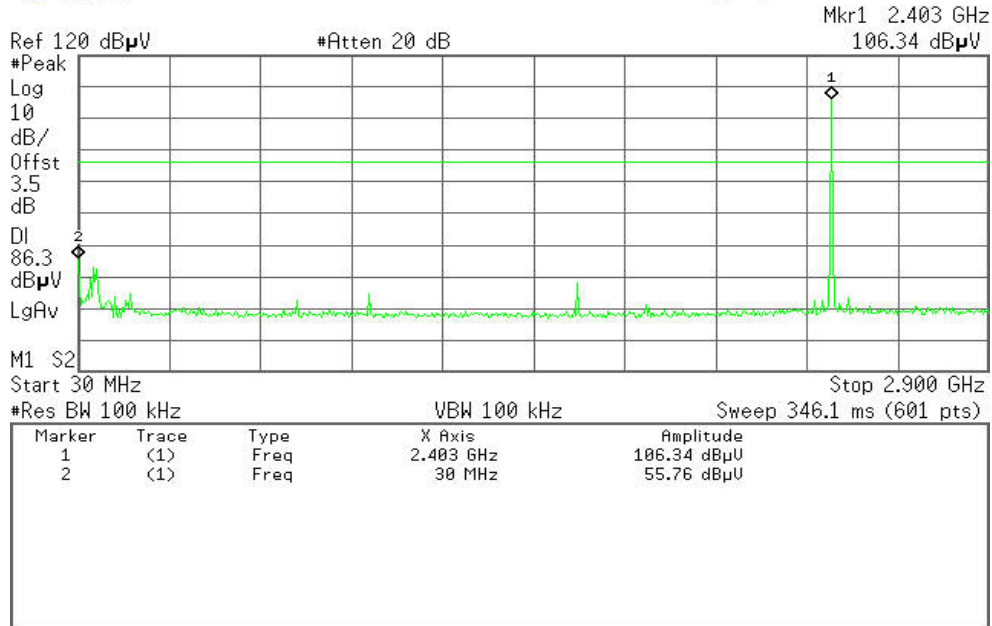

**2.9GHz ~26.5GHz**

Agilent

R T

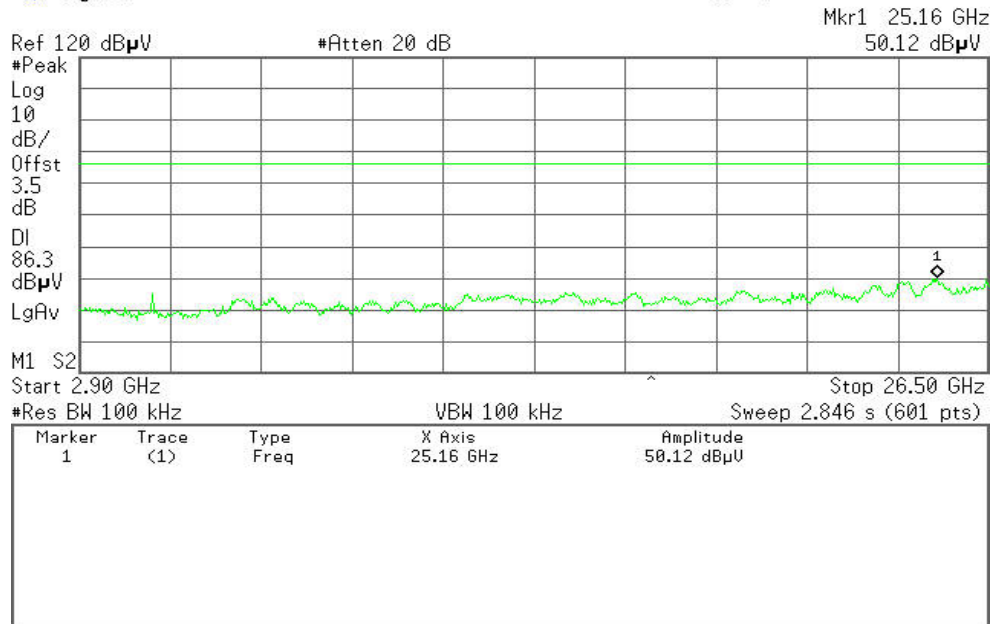



CH Mid

30MHz ~ 2.9GHz

Agilent

R T

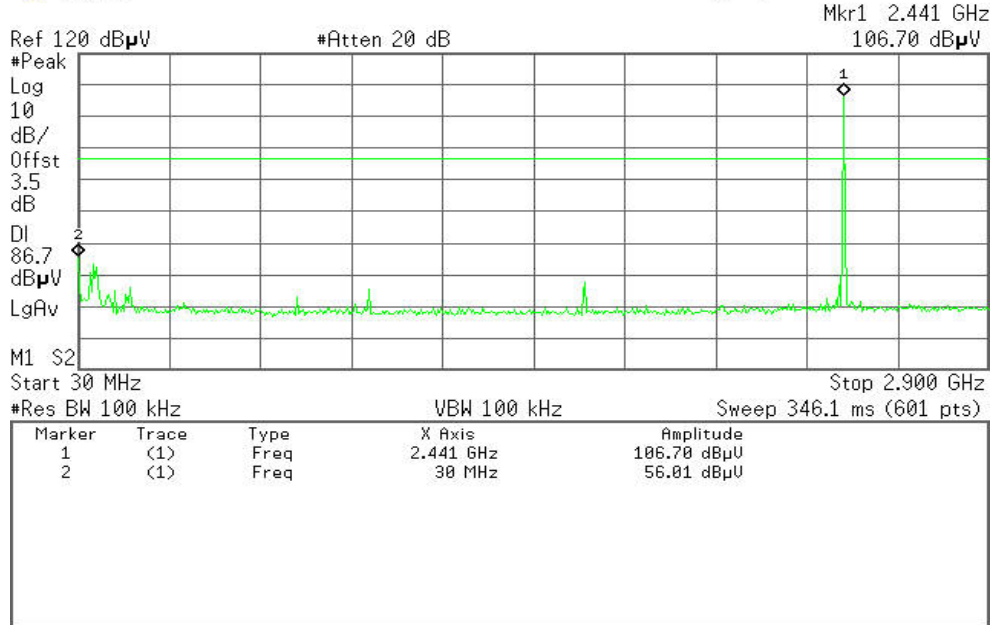

2.9GHz ~ 26.5GHz

Agilent

R T

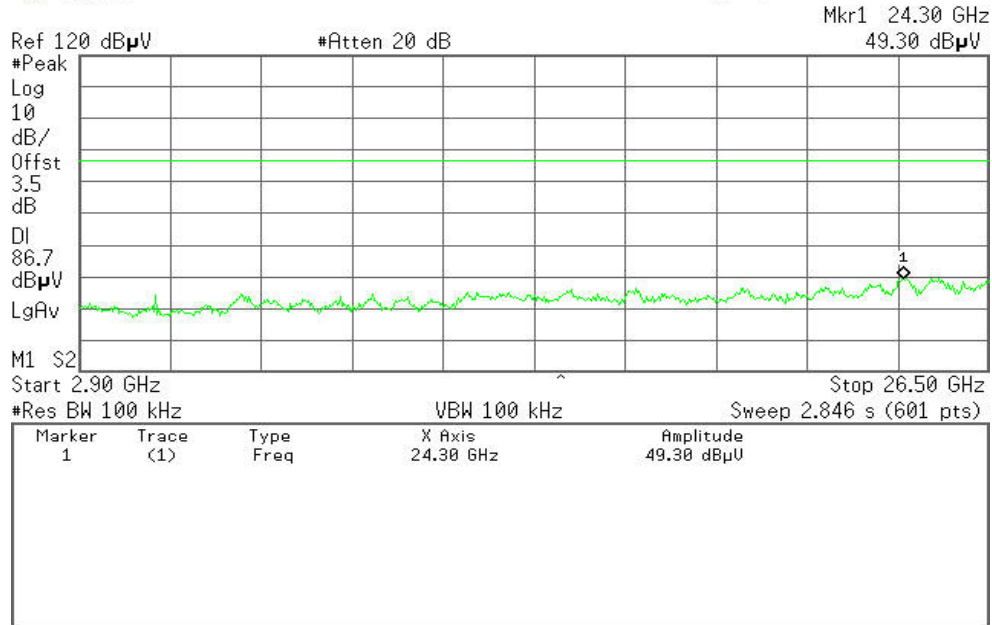



**CH High**

**30MHz ~ 2.9GHz**

Agilent

R T

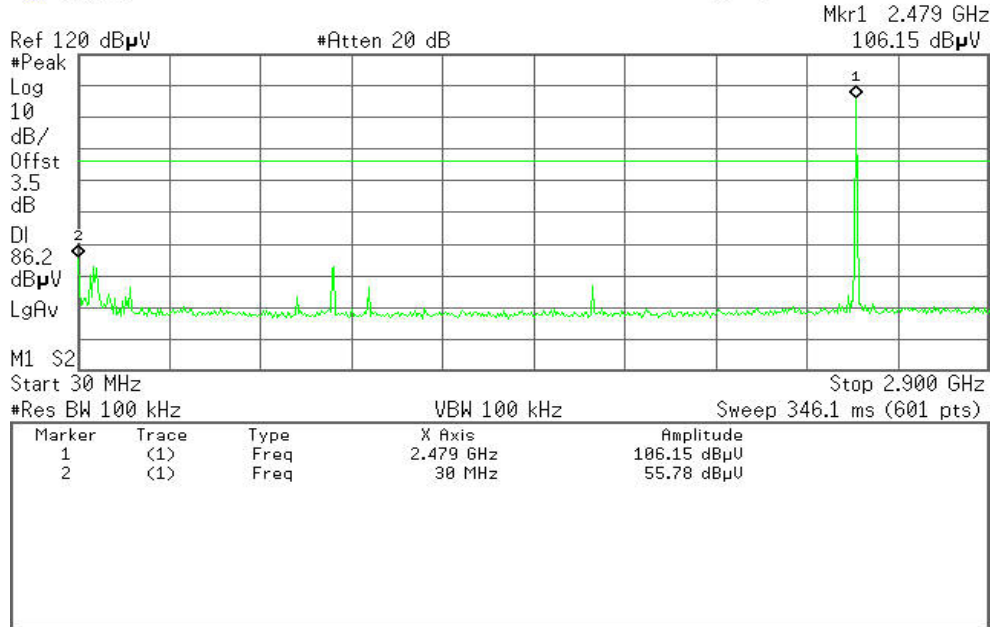

**2.9GHz ~ 26.5GHz**

Agilent

R T

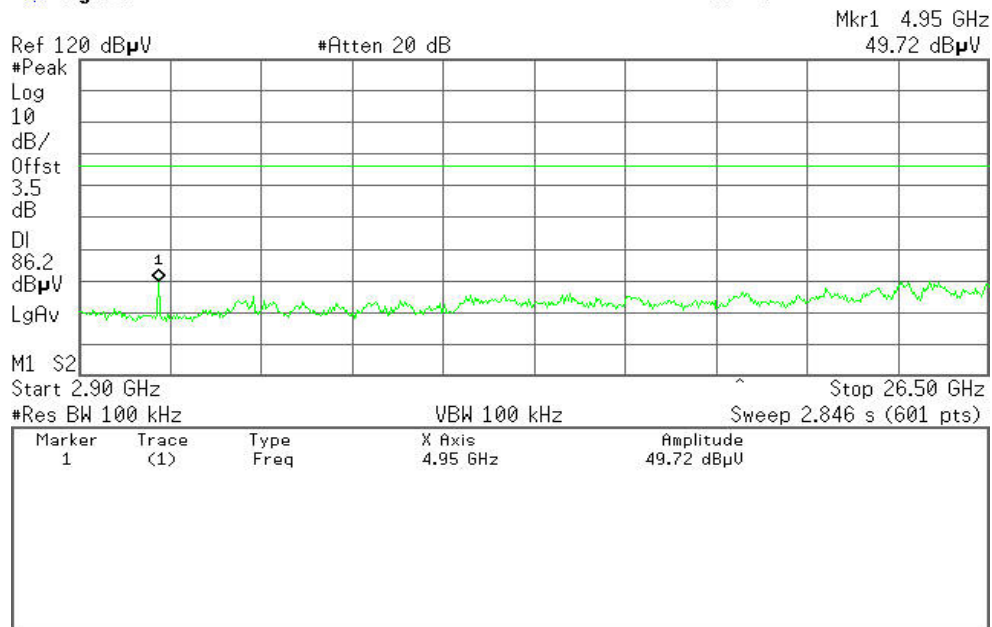



Test Plot (8DPSK )

CH Low

30MHz ~2.9GHz

Agilent

R T

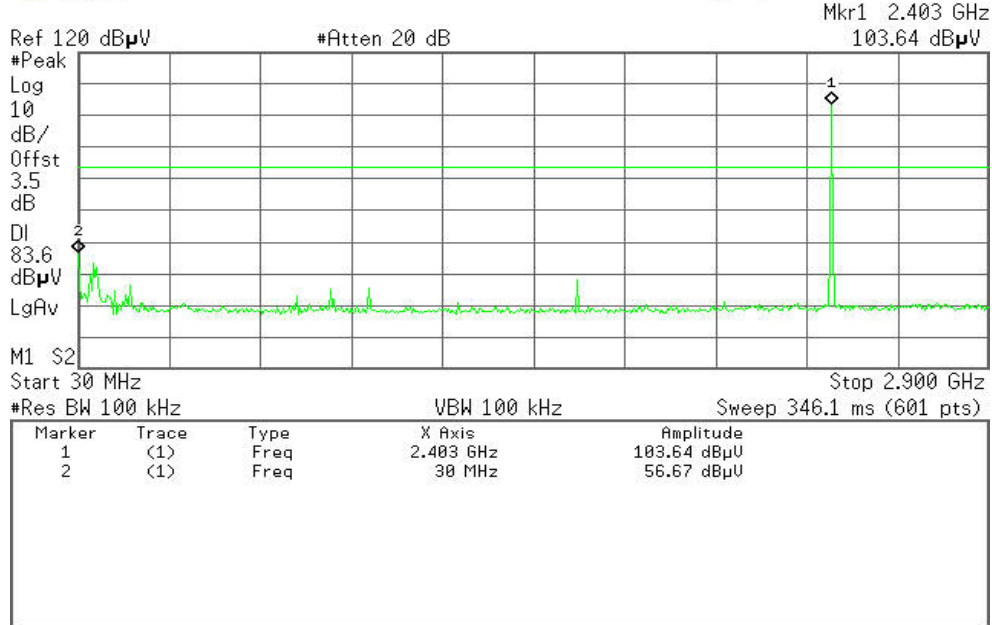

2.9GHz ~26.5GHz

Agilent

R T

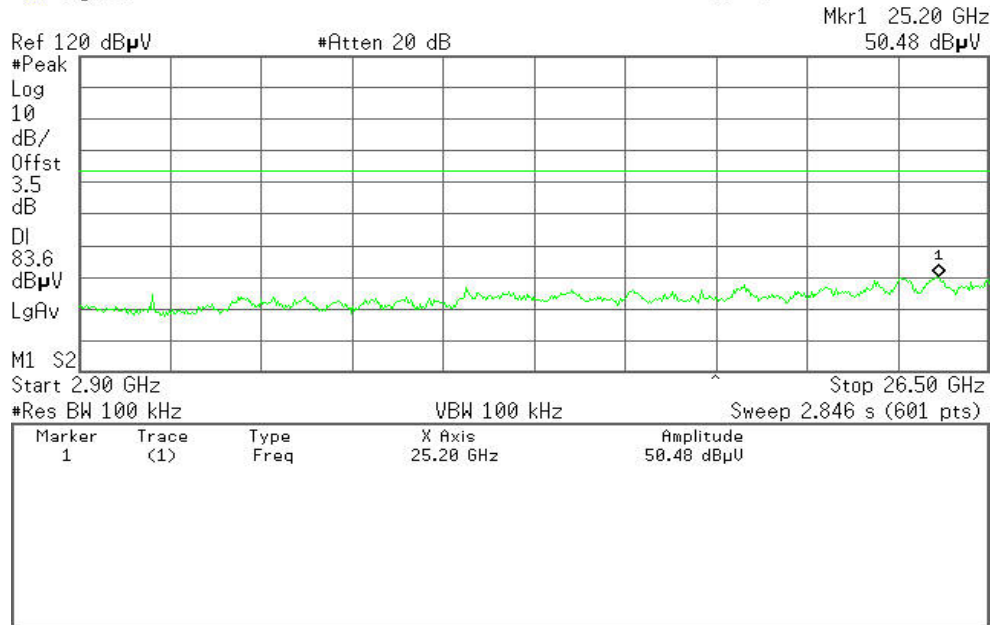



CH Mid

30MHz ~ 2.7GHz

Agilent

R T

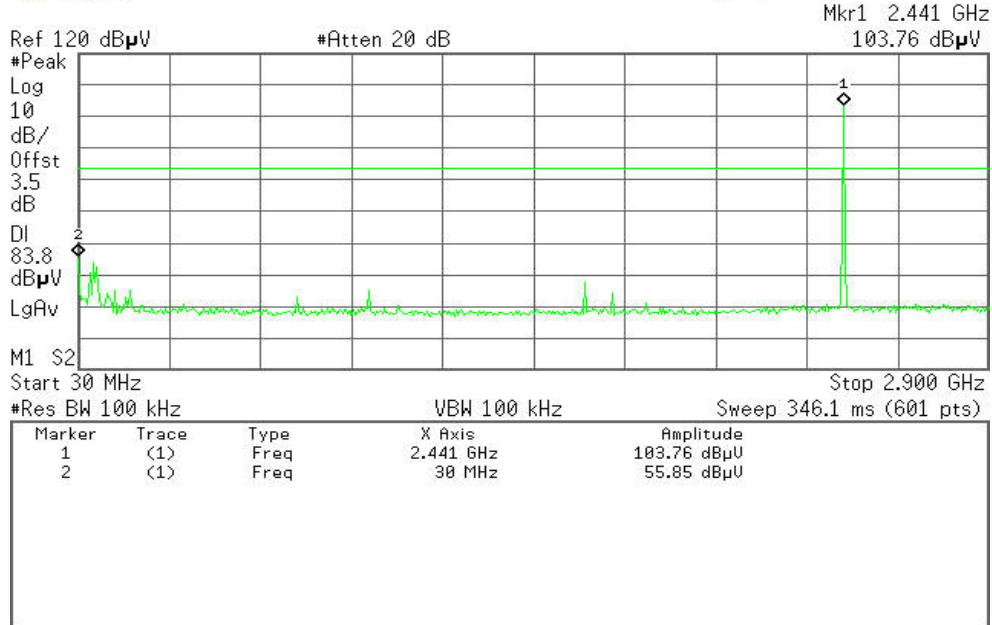

2.9GHz ~ 26.5GHz

Agilent

R T

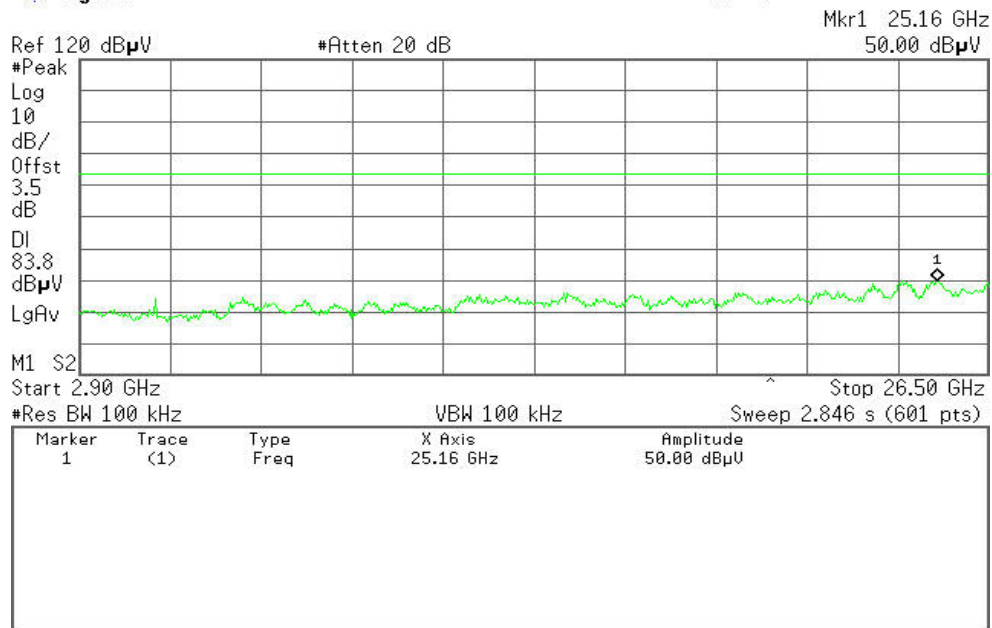



CH High

30MHz ~ 2.9GHz

Agilent

R T

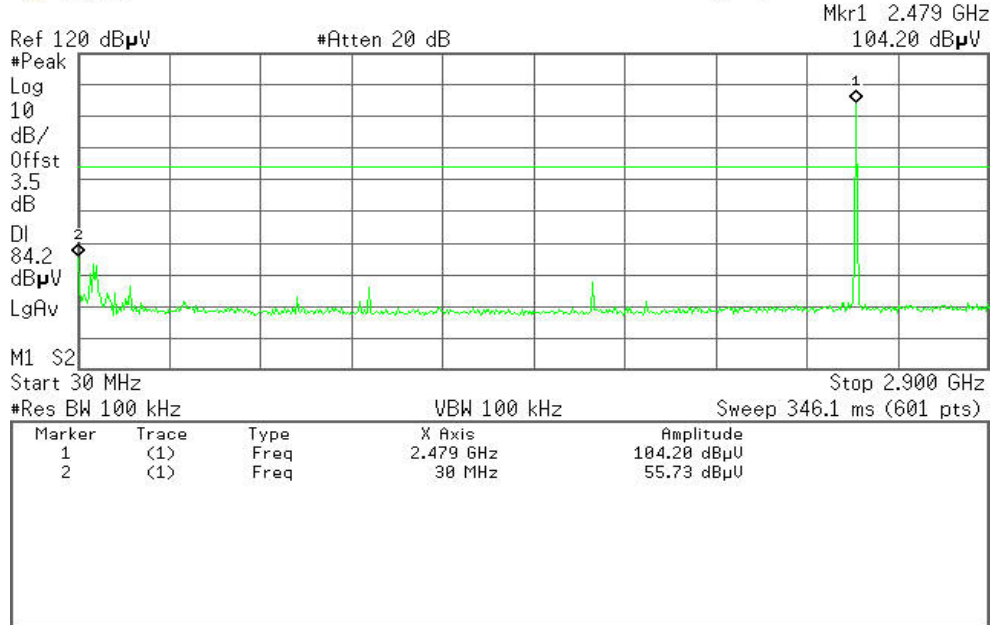

2.9GHz ~ 26.5GHz

Agilent

R T

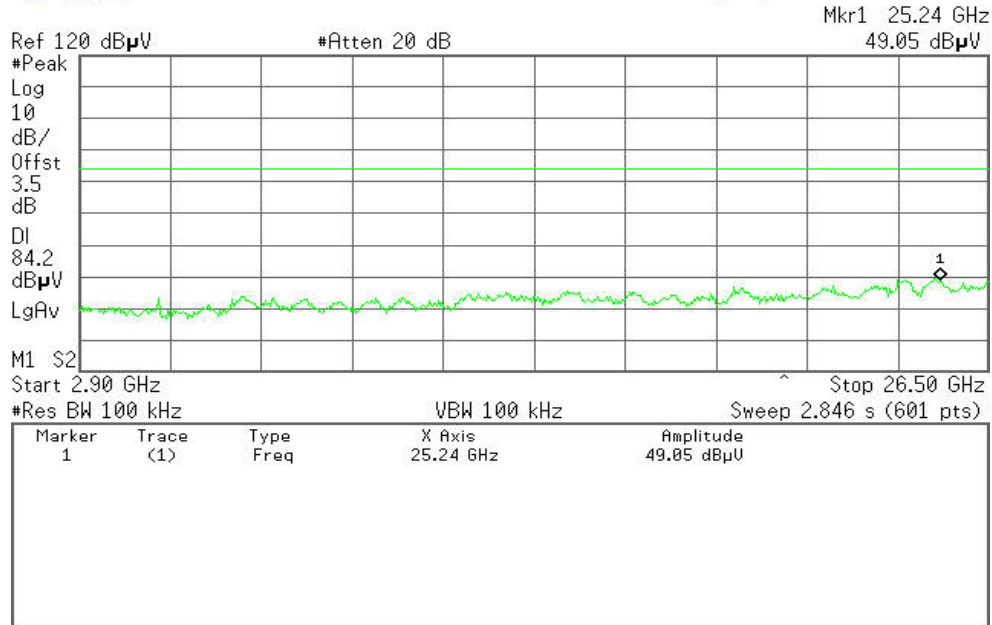



### 6.8.2. Radiated Emissions

#### LIMIT

1. Except as provided elsewhere in this Subpart, the emissions from an intentional radiator shall not exceed the field strength levels specified in the following table:

Frequency (MHz)	Field Strength (mV/m)	Measurement Distance (m)
0.009-0.490	2400/F(kHz)	300
0.490-1.705	24000/F(kHz)	30
1.705-30.0	30	30
30-88	100*	3
88-216	150*	3
216-960	200*	3
Above 960	500	3

**Note:** Except as provided in paragraph (g), fundamental emissions from intentional radiators operating under this Section shall not be located in the frequency bands 54-72 MHz, 76-88 MHz, 174-216 MHz or 470-806 MHz. However, operation within these frequency bands is permitted under other sections of this Part, e.g., Sections 15.231 and 15.241.

2. In the above emission table, the tighter limit applies at the band edges.

Frequency (Hz)	Field Strength ( $\mu$ V/m at 3-meter)	Field Strength (dB $\mu$ V/m at 3-meter)
30-88	100	40
88-216	150	43.5
216-960	200	46
Above 960	500	54



**MEASUREMENT EQUIPMENT USED**

Radiated Emission Test Site 966(2)					
Name of Equipment	Manufacturer	Model Number	Serial Number	Last Calibration	Due Calibration
PSA Series Spectrum Analyzer	Agilent	E4446A	US44300399	03/19/2012	03/19/2013
ESCI EMI TEST RECEIVER.ESCI	ROHDE&SCHWARZ	ESCI	100783	03/17/2012	03/17/2013
Amplifier	MITEQ	AM-1604-3000	1123808	03/18/2012	03/18/2013
Turn Table	EMCO	2081-1.21	N/A	N.C.R	N.C.R
Controller	CT	N/A	N/A	N.C.R	N.C.R
High Noise Amplifier	Agilent	8449B	3008A01838	03/18/2012	03/18/2013
Bilog Antenna	SCHAFFNER	CBL6143	5082	03/17/2012	03/17/2013
Horn Antenna	SCHWARZBECK	BBHA9120	D286	03/17/2012	03/17/2013
Loop Antenna	A. R. A	PLA-1030/B	1029	03/23/2012	03/23/2013
Temp. / Humidity Meter	VICTOR	VC230	N/A	03/19/2012	03/19/2013
Antenna Tower	SUNOL	TLT2	N/A	N.C.R	N.C.R
Test S/W	FARAD	LZ-RF / CCS-SZ-3A2			

**Remark:** Each piece of equipment is scheduled for calibration once a year.





**Test Configuration**

**Below 1 GHz**

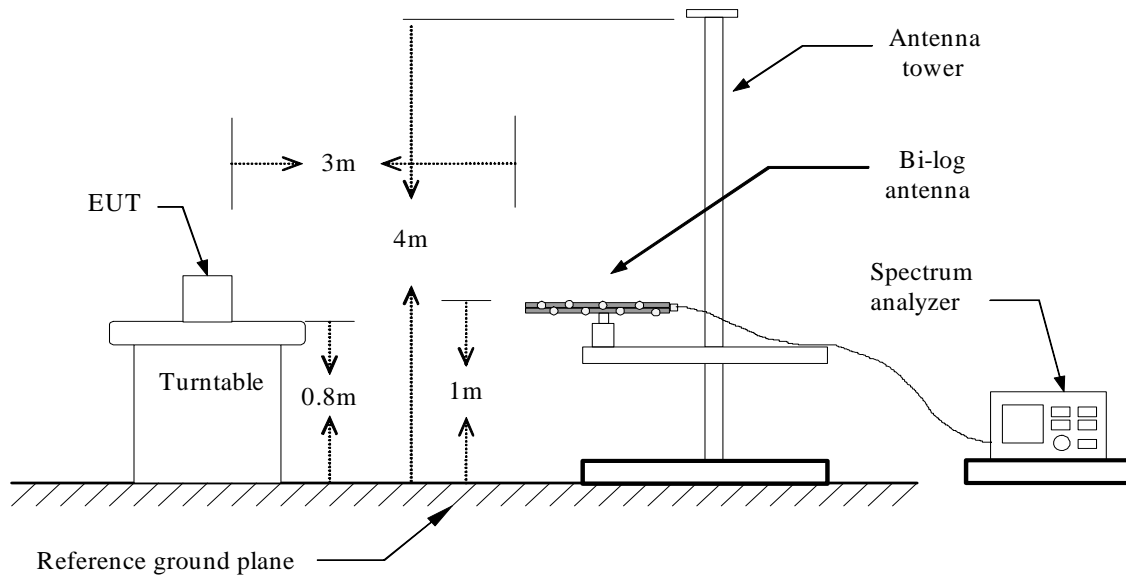

**Above 1 GHz**

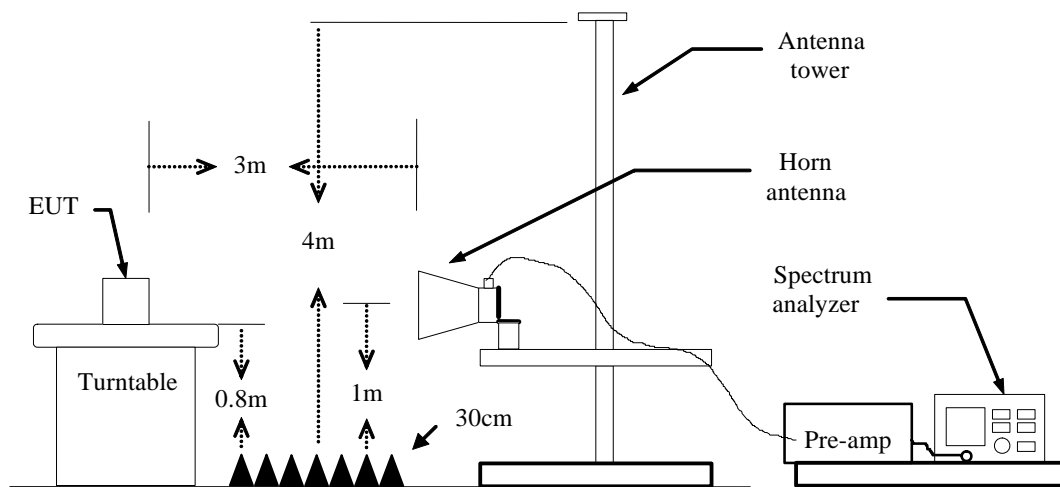



## **TEST PROCEDURE**

1. The EUT is placed on a turntable, which is 0.8m above ground plane.
2. The turntable shall be rotated for 360 degrees to determine the position of maximum emission level.
3. EUT is set 3m away from the receiving antenna, which is varied from 1m to 4m to find out the highest emissions.
4. Maximum procedure was performed on the six highest emissions to ensure EUT compliance.
5. And also, each emission was to be maximized by changing the polarization of receiving antenna both horizontal and vertical.
6. Repeat above procedures until the measurements for all frequencies are complete.



TEST RESULTS

Below 1 GHz

Operation Mode: TX

Test Date: December 10,2012

Temperature: 24°C

Tested by: Leevin Li

Humidity: 52% RH

Polarity: Ver. / Hor.

Table with 8 columns: Frequency (MHz), Reading (dBµV), Correction Factor (dB/m), Result (dBµV/m), Limit (dBµV/m), Margin (dB), Antenna Pole (V/H), Remark. It contains 15 rows of test data.

\*\*Remark: No emission found between lowest internal used/generated frequency to 30MHz.

Notes:

- 1. Measuring frequencies from 9kHz to the 1GHz.
2. Radiated emissions measured in frequency range from 30MHz to 1GHz were made with an instrument using Peak/Quasi-peak detector mode.
3. Data of measurement within this frequency range shown " --- " in the table above means the reading of emissions are attenuated more than 20dB below the permissible limits or the field strength is too small to be measured.
4. The IF bandwidth of SPA between 30MHz to 1GHz was 120kHz.
5. Frequency (MHz) = Emission frequency in MHz
Reading (dBuV) = Receiver reading
Correction Factor(dB/m) = Antenna factor + Cable loss – Amplifier gain
Actual FS (dBuV/m) = Reading (dBuV) + Corr. Factor (dB/m)
Limit (dBuV/m) = Limit stated in standard
Margin(dB) = Measured (dBuV/m) – Limits (dBuV/m)
Antenna Pole(V/H) = Current carrying line of reading



Above 1 GHz

GFSK

Operation

Mode:

TX(CH Low)

Test Date:

December 10,2012

Temperature:

24°C

Tested by:

Leevin Li

Humidity:

52% RH

Polarity:

Ver. / Hor.

Frequency (MHz)	Reading (dBµV)	Correction Factor (dB/m)	Result (dBµV/m)	Limit (dBµV/m)	Margin (dB)	Antenna Pole (V/H)	Remark
1595.0000	51.83	-8.44	43.39	74.00	-30.61	V	peak
3040.0000	52.18	-5.46	46.72	74.00	-27.28	V	peak
3238.3332	50.38	-3.55	46.83	74.00	-27.17	V	peak
3663.3332	46.98	-0.87	46.11	74.00	-27.89	V	peak
4230.0000	48.91	0.12	49.03	74.00	-24.97	V	peak
4796.6666	59.69	2.68	62.37	74.00	-11.63	V	peak
4796.6667	37.98	2.68	40.66	54.00	-13.34	V	AVG
1141.6666	53.92	-10.63	43.29	74.00	-30.71	H	Peak
1595.0000	51.16	-8.44	42.72	74.00	-31.28	H	Peak
3323.3332	47.31	-2.73	44.58	74.00	-29.42	H	Peak
3833.3332	47.54	-0.70	46.84	74.00	-27.16	H	Peak
4796.6666	67.56	2.68	70.24	74.00	-3.76	H	Peak
4796.6667	39.06	2.68	41.74	54.00	-12.26	H	AVG
5845.0000	44.98	6.59	51.57	74.00	-22.43	H	peak

Notes:

1. Measuring frequencies from 1 GHz to the 10th harmonic of highest fundamental frequency.
2. Measurements above show only up to 6 maximum emissions noted, or would be lesser if no specific emissions from the EUT are recorded (ie: margin>20dB from the applicable limit) and considered that's already beyond the background noise floor.
3. Radiated emissions measured in frequency above 1000MHz were made with an instrument using Peak detector mode and average detector mode of the emission shown in Actual FS column.
4. Spectrum setting:
  - a. Peak Setting 1GHz - 26GHz, RBW = 1MHz, VBW = 1MHz, Sweep time = 200 ms.
  - b. AV Setting 1GH z- 26GHz, RBW = 1MHz, VBW = 10Hz, Sweep time = 200 ms.
5. Frequency (MHz) = Emission frequency in MHz  
 Reading (dBµV/m) =Uncorrected Analyzer / Receiver Reading  
 Correction Factor (dB) = Antenna factor + Cable loss – Amplifier gain  
 Limit (dBµV/m) = Limit stated in standard  
 Margin (dB) = Result (dBµV/m)- Limit (dBµV/m)  
 Pk = Peak Reading  
 AV. = Average Reading  
 Remark = Mark Peak Reading or Average Reading



Operation Mode: TX(CH Mid)

Test Date: December 10,2012

Temperature: 24°C

Tested by: Leevin Li

Humidity: 52% RH

Polarity: Ver. / Hor.

Frequency (MHz)	Reading (dBµV)	Correction Factor (dB/m)	Result (dBµV/m)	Limit (dBµV/m)	Margin (dB)	Antenna Pole (V/H)	Remark
1623.3333	52.70	-8.38	44.32	74.00	-29.68	V	Peak
3040.0000	51.16	-5.46	45.70	74.00	-28.30	V	Peak
3238.3332	50.41	-3.55	46.86	74.00	-27.14	V	Peak
4230.0000	48.70	0.12	48.82	74.00	-25.18	V	Peak
4881.6666	59.50	3.20	62.70	74.00	-11.30	V	Peak
4881.6666	39.17	3.20	42.37	54.00	-11.63	V	AVG
7318.3333	49.29	7.33	56.62	74.00	-17.38	V	Peak
7318.3333	33.52	7.33	40.85	54.00	-13.15	V	AVG
1623.3333	48.01	-8.38	39.63	74.00	-34.37	H	Peak
3323.3332	46.62	-2.73	43.89	74.00	-30.11	H	Peak
3833.3332	45.61	-0.70	44.91	74.00	-29.09	H	Peak
4230.0000	45.43	0.12	45.55	74.00	-28.45	H	Peak
4881.6666	62.78	3.20	65.98	74.00	-8.02	H	peak
4881.6666	38.19	3.20	41.39	54.00	-12.61	H	AVG
5703.3333	45.44	5.68	51.12	74.00	-22.88	H	peak

Notes:

- Measuring frequencies from 1 GHz to the 10th harmonic of highest fundamental frequency.
- Measurements above show only up to 6 maximum emissions noted, or would be lesser if no specific emissions from the EUT are recorded (ie: margin>20dB from the applicable limit) and considered that's already beyond the background noise floor.
- Radiated emissions measured in frequency above 1000MHz were made with an instrument using Peak detector mode and average detector mode of the emission shown in Actual FS column.
- Spectrum setting:
  - Peak Setting 1GHz - 26GHz, RBW = 1MHz, VBW = 1MHz, Sweep time = 200 ms.
  - AV Setting 1GH z- 26GHz, RBW = 1MHz, VBW = 10Hz, Sweep time = 200 ms.
- Frequency (MHz) = Emission frequency in MHz  
 Reading (dBµV/m) =Uncorrected Analyzer / Receiver Reading  
 Correction Factor (dB) = Antenna factor + Cable loss – Amplifier gain  
 Limit (dBµV/m) = Limit stated in standard  
 Margin (dB) = Result (dBµV/m)- Limit (dBµV/m)  
 Pk = Peak Reading  
 AV. = Average Reading  
 Remark = Mark Peak Reading or Average Reading



Operation Mode: TX(CH High)

Test Date: December 10,2012

Temperature: 24 °C

Tested by: Leevin Li

Humidity: 52% RH

Polarity: Ver. / Hor.

Frequency (MHz)	Reading (dBµV)	Correction Factor (dB/m)	Result (dBµV/m)	Limit (dBµV/m)	Margin (dB)	Antenna Pole (V/H)	Remark
1651.6666	52.18	-8.37	43.81	74.00	-30.19	V	Peak
3238.3332	50.97	-3.55	47.42	74.00	-26.58	V	Peak
4230.0000	47.31	0.12	47.43	74.00	-26.57	V	Peak
4966.6666	59.10	3.72	62.82	74.00	-11.18	V	Peak
4966.6667	37.91	3.72	41.63	54.00	-12.37	V	AVG
5420.0000	45.42	4.30	49.72	74.00	-24.28	V	Peak
7431.6666	48.88	7.41	56.29	74.00	-17.71	V	Peak
7431.6666	32.29	7.41	39.70	54.00	-14.30	V	AVG
1651.6666	55.93	-8.37	47.56	74.00	-26.44	H	Peak
3238.3332	48.10	-3.55	44.55	74.00	-29.45	H	Peak
3861.6667	46.48	-0.67	45.81	74.00	-28.19	H	Peak
4230.0000	45.77	0.12	45.89	74.00	-28.11	H	Peak
4966.6666	67.70	3.72	71.42	74.00	-2.58	H	Peak
4966.6666	43.88	3.72	47.60	54.00	-6.40	H	AVG
5731.6665	44.93	5.86	50.79	74.00	-23.21	H	Peak

Notes:

1. Measuring frequencies from 1 GHz to the 10th harmonic of highest fundamental frequency.
2. Measurements above show only up to 6 maximum emissions noted, or would be lesser if no specific emissions from the EUT are recorded (ie: margin>20dB from the applicable limit) and considered that's already beyond the background noise floor.
3. Radiated emissions measured in frequency above 1000MHz were made with an instrument using Peak detector mode and average detector mode of the emission shown in Actual FS column.
4. Spectrum setting:
  - a. Peak Setting 1GHz - 26GHz, RBW = 1MHz, VBW = 1MHz, Sweep time = 200 ms.
  - b. AV Setting 1GH z- 26GHz, RBW = 1MHz, VBW = 10Hz, Sweep time = 200 ms.
5. Frequency (MHz) = Emission frequency in MHz  
 Reading (dBµV/m) =Uncorrected Analyzer / Receiver Reading  
 Correction Factor (dB) = Antenna factor + Cable loss – Amplifier gain  
 Limit (dBµV/m) = Limit stated in standard  
 Margin (dB) = Result (dBµV/m)- Limit (dBµV/m)  
 Pk = Peak Reading  
 AV. = Average Reading  
 Remark = Mark Peak Reading or Average Reading



8DPSK

Operation Mode:

TX(CH Low)

Test Date: December 10,2012

Temperature: 24°C

Tested by: Leevin Li

Humidity: 52% RH

Polarity: Ver. / Hor.

Frequency (MHz)	Reading (dBµV)	Correction Factor (dB/m)	Result (dBµV/m)	Limit (dBµV/m)	Margin (dB)	Antenna Pole (V/H)	Remark
1595.0000	52.64	-8.44	44.20	74.00	-29.80	V	Peak
3040.0000	51.20	-5.46	45.74	74.00	-28.26	V	Peak
3238.3332	49.88	-3.55	46.33	74.00	-27.67	V	Peak
3465.0000	48.19	-1.37	46.82	74.00	-27.18	V	Peak
4230.0000	49.96	0.12	50.08	74.00	-23.92	V	Peak
4796.6666	53.45	2.68	56.13	74.00	-17.87	V	Peak
4796.6667	35.52	2.68	38.20	54.00	-15.80	V	AVG
1595.0000	51.60	-8.44	43.16	74.00	-30.84	H	Peak
2020.0000	48.01	-6.63	41.38	74.00	-32.62	H	Peak
3011.6667	50.16	-5.73	44.43	74.00	-29.57	H	Peak
3833.3332	46.72	-0.70	46.02	74.00	-27.98	H	Peak
4796.6666	62.55	2.68	65.23	74.00	-8.77	H	Peak
4796.6667	37.17	2.68	39.85	54.00	-14.15	H	AVG
5051.6666	47.10	3.97	51.07	74.00	-22.93	H	Peak

Notes:

1. Measuring frequencies from 1 GHz to the 10th harmonic of highest fundamental frequency.
2. Measurements above show only up to 6 maximum emissions noted, or would be lesser if no specific emissions from the EUT are recorded (ie: margin>20dB from the applicable limit) and considered that's already beyond the background noise floor.
3. Radiated emissions measured in frequency above 1000MHz were made with an instrument using Peak detector mode and average detector mode of the emission shown in Actual FS column.
4. Spectrum setting:
  - a. Peak Setting 1GHz - 26GHz, RBW = 1MHz, VBW = 1MHz, Sweep time = 200 ms.
  - b. AV Setting 1GH z- 26GHz, RBW = 1MHz, VBW = 10Hz, Sweep time = 200 ms.
5. Frequency (MHz) = Emission frequency in MHz  
 Reading (dBµV/m) =Uncorrected Analyzer / Receiver Reading  
 Correction Factor (dB) = Antenna factor + Cable loss – Amplifier gain  
 Limit (dBµV/m) = Limit stated in standard  
 Margin (dB) = Result (dBµV/m)- Limit (dBµV/m)  
 Pk = Peak Reading  
 AV. = Average Reading  
 Remark = Mark Peak Reading or Average Reading



Operation Mode: TX(CH Mid)

Test Date: December 10,2012

Temperature: 24°C

Tested by: Leevin Li

Humidity: 52% RH

Polarity: Ver. / Hor.

Frequency (MHz)	Reading (dBµV)	Correction Factor (dB/m)	Result (dBµV/m)	Limit (dBµV/m)	Margin (dB)	Antenna Pole (V/H)	Remark
1623.3333	51.64	-8.38	43.26	74.00	-30.74	V	Peak
2218.3332	52.00	-6.91	45.09	74.00	-28.91	V	Peak
3040.0000	52.11	-5.46	46.65	74.00	-27.35	V	Peak
3238.3333	51.04	-3.55	47.49	74.00	-26.51	V	Peak
4230.0000	48.97	0.12	49.09	74.00	-24.91	V	Peak
4881.6666	56.48	3.20	59.68	74.00	-14.32	V	Peak
4881.6666	33.34	3.20	36.54	54.00	-17.46	V	AVG
1141.6666	51.32	-10.63	40.69	74.00	-33.31	H	Peak
1623.3333	53.77	-8.38	45.39	74.00	-28.61	H	Peak
3408.3332	46.67	-1.91	44.76	74.00	-29.24	H	Peak
3833.3332	46.98	-0.70	46.28	74.00	-27.72	H	Peak
4881.6666	57.32	3.20	60.52	74.00	-13.48	H	Peak
4881.6667	37.50	3.20	40.70	54.00	-13.30	H	AVG
5618.3333	44.53	5.13	49.66	74.00	-24.34	H	Peak

Notes:

1. Measuring frequencies from 1 GHz to the 10th harmonic of highest fundamental frequency.
2. Measurements above show only up to 6 maximum emissions noted, or would be lesser if no specific emissions from the EUT are recorded (ie: margin>20dB from the applicable limit) and considered that's already beyond the background noise floor.
3. Radiated emissions measured in frequency above 1000MHz were made with an instrument using Peak detector mode and average detector mode of the emission shown in Actual FS column.
4. Spectrum setting:
  - a. Peak Setting 1GHz - 26GHz, RBW = 1MHz, VBW = 1MHz, Sweep time = 200 ms.
  - b. AV Setting 1GH z- 26GHz, RBW = 1MHz, VBW = 10Hz, Sweep time = 200 ms.
5. Frequency (MHz) = Emission frequency in MHz  
 Reading (dBµV/m) =Uncorrected Analyzer / Receiver Reading  
 Correction Factor (dB) = Antenna factor + Cable loss – Amplifier gain  
 Limit (dBµV/m) = Limit stated in standard  
 Margin (dB) = Result (dBµV/m)- Limit (dBµV/m)  
 Pk = Peak Reading  
 AV. = Average Reading  
 Remark = Mark Peak Reading or Average Reading





Operation Mode: TX(CH High)
Temperature: 24 °C
Humidity: 52% RH

Test Date: December 10,2012
Tested by: Leevin Li
Polarity: Ver. / Hor.

Table with 8 columns: Frequency (MHz), Reading (dBµV), Correction Factor (dB/m), Result (dBµV/m), Limit (dBµV/m), Margin (dB), Antenna Pole (V/H), Remark. It contains two groups of data rows for various frequencies and their corresponding measurements.

Notes:

- 1. Measuring frequencies from 1 GHz to the 10th harmonic of highest fundamental frequency.
2. Measurements above show only up to 6 maximum emissions noted, or would be lesser if no specific emissions from the EUT are recorded (ie: margin>20dB from the applicable limit) and considered that's already beyond the background noise floor.
3. Radiated emissions measured in frequency above 1000MHz were made with an instrument using Peak detector mode and average detector mode of the emission shown in Actual FS column.
4. Spectrum setting:
a. Peak Setting 1GHz - 26GHz, RBW = 1MHz, VBW = 1MHz, Sweep time = 200 ms.
b. AV Setting 1GH z- 26GHz, RBW = 1MHz, VBW = 10Hz, Sweep time = 200 ms.
5. Frequency (MHz) = Emission frequency in MHz
Reading (dBµV/m) =Uncorrected Analyzer / Receiver Reading
Correction Factor (dB) = Antenna factor + Cable loss – Amplifier gain
Limit (dBµV/m) = Limit stated in standard
Margin (dB) = Result (dBµV/m)- Limit (dBµV/m)
Pk = Peak Reading
AV. = Average Reading
Remark = Mark Peak Reading or Average Reading



### 6.9 POWERLINE CONDUCTED EMISSIONS

#### LIMIT

For an intentional radiator which is designed to be connected to the public utility (AC) power line, the radio frequency voltage that is conducted back onto the AC power line on any frequency or frequencies within the band 150 kHz to 30 MHz shall not exceed 250 microvolts (The limit decreases linearly with the logarithm of the frequency in the range 0.15 MHz to 0.50 MHz). The limits at specific frequency range is listed as follows:

Frequency Range (MHz)	Limits (dBµV)	
	Quasi-peak	Average
0.15 to 0.50	66 to 56	56 to 46
0.50 to 5	56	46
5 to 30	60	50

Compliance with this provision shall be based on the measurement of the radio frequency voltage between each power line (LINE and NEUTRAL) and ground at the power terminals.

#### MEASUREMENT EQUIPMENT USED

Conducted Emission Test Site					
Name of Equipment	Manufacturer	Model Number	Serial Number	Last Calibration	Due Calibration
ESCI EMI TEST RECEIVER.ESCI	ROHDE&SCHWARZ	ESCI	100783	03/17/2012	03/17/2013
LISN(EUT)	ROHDE&SCHWARZ	ENV216	101543	09/20/2012	09/20/2013
LISN	EMCO	3825/2	8901-1459	03/19/2012	03/19/2013
Temp. / Humidity Meter	VICTOR	HTC-1	2	03/20/2012	03/20/2013
Test S/W	FARAD	EZ-EMC/ CCS-3A1-CE			

**Remark:** Each piece of equipment is scheduled for calibration once a year.



## Test Configuration

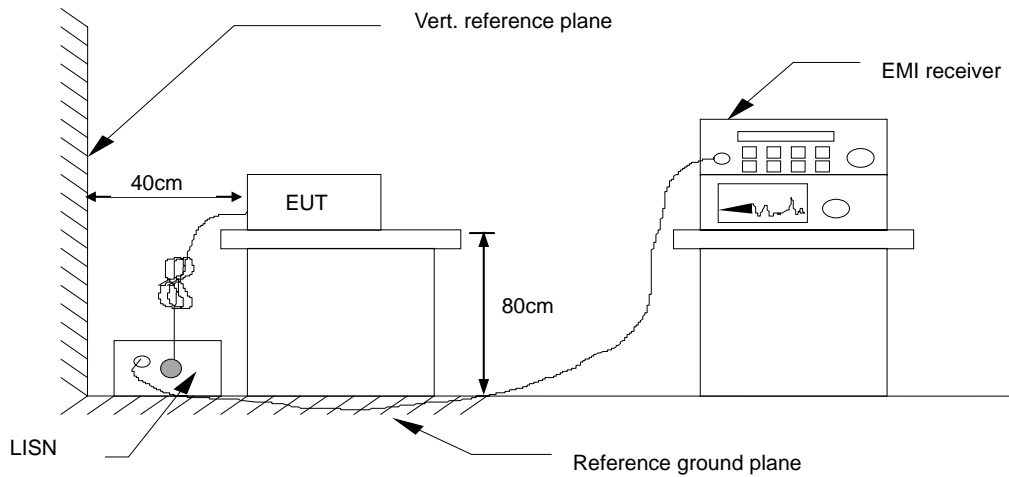

See test photographs attached in Appendix 1 for the actual connections between EUT and support equipment.

## TEST PROCEDURE

1. The EUT was placed on a table, which is 0.8m above ground plane.
2. Maximum procedure was performed on the six highest emissions to ensure EUT compliance.
3. Repeat above procedures until all frequency measured were complete.

## TEST RESULTS

The initial step in collecting conducted data is a spectrum analyzer peak scan of the measurement range. Significant peaks are then marked as shown on the following data page, and these signals are then quasi-peaked.



Test Data

Operation Mode: Normal Test Date: November 20,2012
Temperature: 22°C Humidity: 45% RH
Tested by: Viking Yuan

Table with 11 columns: Frequency (MHz), QuasiPeak Reading (dBuV), Average Reading (dBuV), Correction Factor (dB), QuasiPeak Result (dBuV), Average Result (dBuV), QuasiPeak Limit (dBuV), Average Limit (dBuV), QuasiPeak Margin (dB), Average Margin (dB), Line (L1/L2). It contains two groups of data rows.

Note:

- 1. Measuring frequencies from 0.15 MHz to 30MHz.
2. The emissions measured in frequency range from 0.15 MHz to 30MHz were made with an instrument using Peak detector, Quasi-peak detector and average detector.
3. "---" denotes the emission level was or more than 2dB below the Average limit.
4. The IF bandwidth of SPA between 0.15MHz to 30MHz was 10kHz; the IF bandwidth of Test Receiver between 0.15MHz to 30MHz was 9kHz;
5. L1= Line One (Live Line)/ L2= Line Two (Neutral Line)