

FCC PART 15 TEST REPORT

For

Ambient light kit

Model: ELAMMD, ELAMMG

Brand: LEVEL MOUNT

FCC ID: VII-ELAMMD

Report No.: AGC10200909SZ02E5

Date of Issue: Sep.19, 2009

Prepared For

ELEXA Consumer Products Inc.

6200N.Hiawatha Ave., 8th Floor, Chicago, USA

TEL: 773-794-1300

FAX: 773-794-1315

Prepared By

Attestation of Global Compliance Co., Ltd.

2F., No.2 Building, Huafeng No.1 Technical Industrial Park, Sanwei,

Xixiang, Baoan District, Shenzhen

TEL: 86-755-2908 1966

FAX: 86-755-2600 8484

TABLE OF CONTENTS

1. VERIFICATION OF COMPLIANCE	2
2. PRODUCT INFORMATION	3
3. TEST FACILITY	4
4. SUPPORT EQUIPMENT LIST	5
5. SYSTEM DESCRIPTION	5
6. FCC LINE CONDUCTED EMISSION TEST	6
6.1. TEST EQUIPMENT OF LINE CONDUCTED EMISSION TEST	6
6.2. LIMITS OF LINE CONDUCTED EMISSION TEST	6
6.3. BLOCK DIAGRAM OF LINE CONDUCTED EMISSION TEST	6
6.4. PROCEDURE OF LINE CONDUCTED EMISSION TEST	7
6.5 TEST RESULT OF LINE CONDUCTED EMISSION TEST	8
7. FCC RADIATED EMISSION TEST	10
7.1. TEST EQUIPMENT OF RADIATED EMISSION	10
7.2. LIMITS OF RADIATED EMISSION TEST	10
7.3 BLOCK DIAGRAM OF RADIATED EMISSION TEST	10
7.4 PROCEDURE OF RADIATED EMISSION TEST	11
7.5 TEST RESULT OF RADIATED EMISSION TEST	12
APPENDIX 1	14
PHOTOGRAPHS OF TEST SETUP	14
APPENDIX 2	15
PHOTOGRAPHS OF EUT	15

1. VERIFICATION OF COMPLIANCE

Equipment Under Test:	Ambient light kit
Model Name:	ELAMMD, ELAMMG
Applicant:	ELEXA Consumer Products Inc.
	6200N.Hiawatha Ave., 8th Floor, Chicago, USA
Manufacturer:	Shenzhen JWL Electronics Co., Ltd.
	C and D Block, XiRong Industrial Estate, Gushu, XiXiang Avenue, BaoAn District, Shenzhen
Type of Test:	FCC Class B
Measurement Procedure:	ANSI C63.4: 2003
File Number:	AGC10200909SZ02E5
Date of test:	Sep.11~Sep.19, 2009
Deviation:	None
Condition of Test Sample:	Normal

The above equipment was tested by Attestation Of Global Compliance Co., Ltd. For compliance with the requirements set forth in the FCC Rules and Regulations Part 15, the measurement procedure according to ANSI C63.4:2003 This said equipment in the configuration described in this report shows the maximum emission levels emanating from equipment are within the compliance requirements.

The test results of this report relate only to the tested sample identified in this report.

Checked By :

Jekey Zhang

Jekey Zhang Sep.19, 2009

Authorized By :

King Zhang

King Zhang Sep.19, 2009

2. PRODUCT INFORMATION

Equipment Under Test:	Ambient light kit					
Housing Type:	Plastic					
Rating Voltage:	DC 16V by Adapter					
Receive frequency:	433.9MHz (only one channel)					
Description of EUT	It is only Receiver, and can't transmit					
Size of EUT:	Length	6.5cm	width	5.3cm	height	2.3cm

I/O Port Information (Applicable Not Applicable)

I/O Port of EUT			
I/O Port Type	Q'TY	Cable	Tested with
DC INPUT PORT	1	1	1
LED OUTPUT PORT	1	1	1

3. TEST FACILITY

Location:	F1, Bldg.A, Changyuan New Material Port, Keyuan Rd., Science & IndustryPark,Nanshan District, 518057 Shenzhen, P.R. China.
Description:	There is one 3m semi-anechoic chamber for final test, the Line Conducted labs are constructed and calibrated to meet the FCC requirements in documents ANSI C63.4 and CISPR 22/EN 55022 requirements.
Site Filing:	The Certificate Registration Number is 752051
Instrument	All measuring equipment is in accord with ANSI C63.4 requirements that meet industry
Tolerance:	regulatory agency and accreditation agency requirement.

Ground Plane:	<p>Two conductive reference ground planes were used during the Line Conducted Emission, one in vertical and the other in horizontal. The dimensions of these ground planes are as below. The vertical ground plane was placed distancing 40 cm to the rear of the wooden test table on where the EUT and the support equipment were placed during test. The horizontal ground plane projected 50 cm beyond the footprint of the EUT system and distanced 80 cm to the wooden test table. For radiated emission test, one horizontal conductive ground plane extended at least 1m beyond the periphery of the EUT and the largest measuring antenna, and covered the entire area between the EUT and the antenna. It has no holes or gaps having longitudinal dimensions larger than one-tenth of a wavelength at the highest frequency of measurement up to 1GHz.</p>
----------------------	---

4. SUPPORT EQUIPMENT LIST

Device Type	Manufacturer	Model Name	Serial No.	Data Cable	Power Cable
--	--	--	--	--	--
--	--	--	--	--	--

**Note: All the above equipment/cables were placed in worse case positions to maximize emission signals during emission test.

Grounding: Grounding was in accordance with the manufacturer's requirements and conditions for the intended use.

5. SYSTEM DESCRIPTION

EUT test procedure:

1. Connect EUT and peripheral devices (if need).
2. Power on the EUT, the EUT begins to work.
3. Make sure the EUT operates normally during the test.

6. FCC LINE CONDUCTED EMISSION TEST

6.1. TEST EQUIPMENT OF LINE CONDUCTED EMISSION TEST

Description	Manufacturer	Model	SERIAL NUMBER	Cal. Date	Cal. Due
EMI Test Receiver	HP	8546A/8546 0A	3625A00349 3448A00325	2009/10	2010/9
LISN	AFJ	LS16	16010222119	2009/04	2010/03

6.2 .LIMITS OF LINE CONDUCTED EMISSION TEST

Frequency	Maximum RF Line Voltage	
	Q.P.(dBuV)	Average(dBuV)
150kHz~500kHz	66-56	56-46
500kHz~5MHz	56	46
5MHz~30MHz	60	50

**Note: 1. The lower limit shall apply at the transition frequency.

2. The limit decreases linearly with the logarithm of the frequency in the range 0.15 MHz to 0.50 MHz

6.3. BLOCK DIAGRAM OF LINE CONDUCTED EMISSION TEST

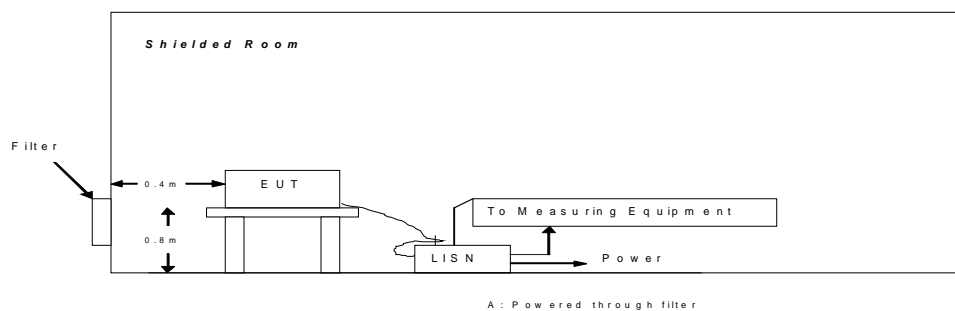

6.4. PROCEDURE OF LINE CONDUCTED EMISSION TEST

- 1) The equipment was set up as per the test configuration to simulate typical actual usage per the user's manual. When the EUT is a tabletop system, a wooden table with a height of 0.8 meters is used and is placed on the ground plane as per ANSI C63.4 (see Test Facility for the dimensions of the ground plane used). When the EUT is a floor-standing equipment, it is placed on the ground plane which has a 3-12 mm non-conductive covering to insulate the EUT from the ground plane.
- 2) Support equipment, if needed, was placed as per ANSI C63.4.
- 3) All I/O cables were positioned to simulate typical actual usage as per ANSI C63.4.
- 4) The EUT received power through a Line Impedance Stabilization Network (LISN) that was grounded to the protect earth.
- 5) All support equipments received AC120V power from a second LISN, if any.
- 6) The EUT test program was started. Emissions were measured on each current carrying line of the EUT using a spectrum Analyzer / Receiver connected to the LISN powering the EUT. The LISN has two monitoring points: Line 1 (Hot Side) and Line 2 (Neutral Side). Two scans were taken: one with Line 1 connected to Analyzer / Receiver and Line 2 connected to a 50 ohm load; the second scan had Line 1 connected to a 50 ohm load and Line 2 connected to the Analyzer / Receiver.
- 7) Analyzer / Receiver scanned from 150 kHz to 30MHz for emissions in each of the test modes.
- 8) During the above scans, the emissions were maximized by cable manipulation.
- 9) A scan was taken on both power lines, Line 1 and Line 2, recording at least the six highest emissions.
- 10) Emission frequency and amplitude were recorded into a computer in which correction factors were used to calculate the emission level and compare reading to the applicable limit. If EUT emission level was less -2dB to the A.V. limit in Peak mode, then the emission signal was re-checked using Q.P and Average detector.
- 11) The test data of the worst case condition(s) was reported on the Summary Data page.

6.5 TEST RESULT OF LINE CONDUCTED EMISSION TEST

TEST RESULT OF LINE CONDUCTED EMISSION-LINE 1

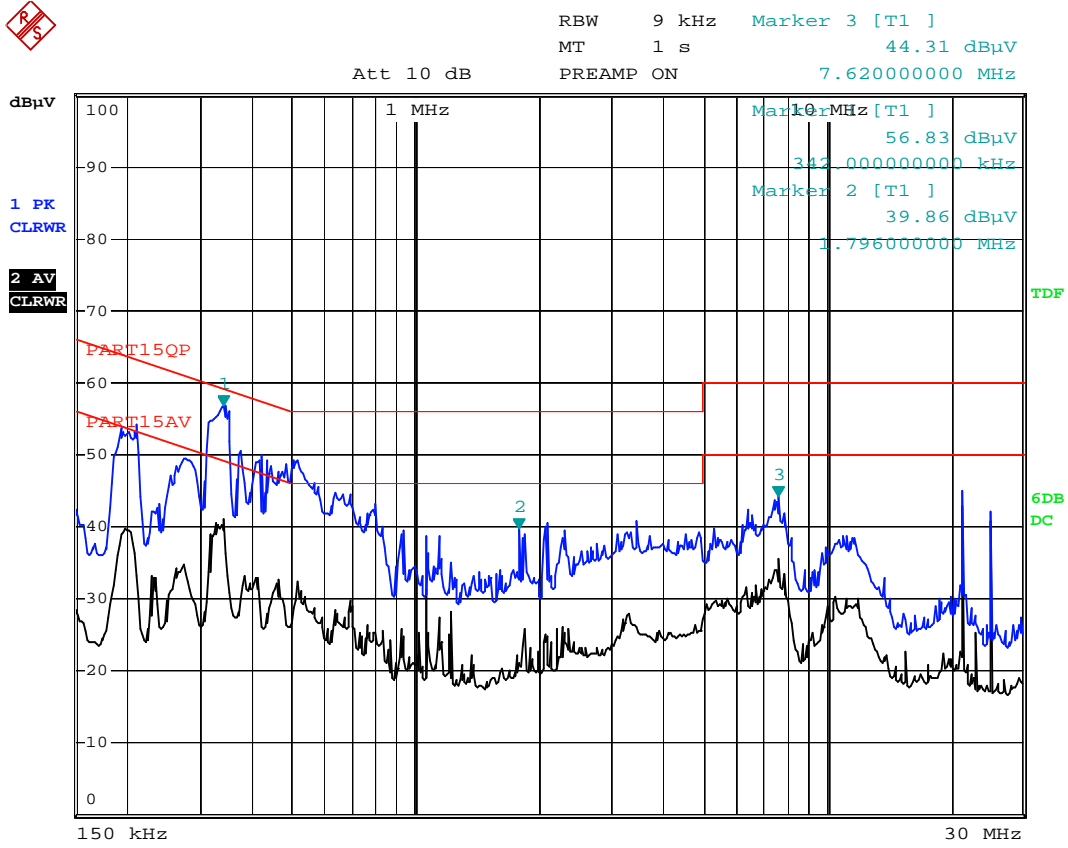

ELAMMD-L

Date: 19.SEP.2009 11:17:30

TEST RESULT OF LINE CONDUCTED EMISSION-LINE 2

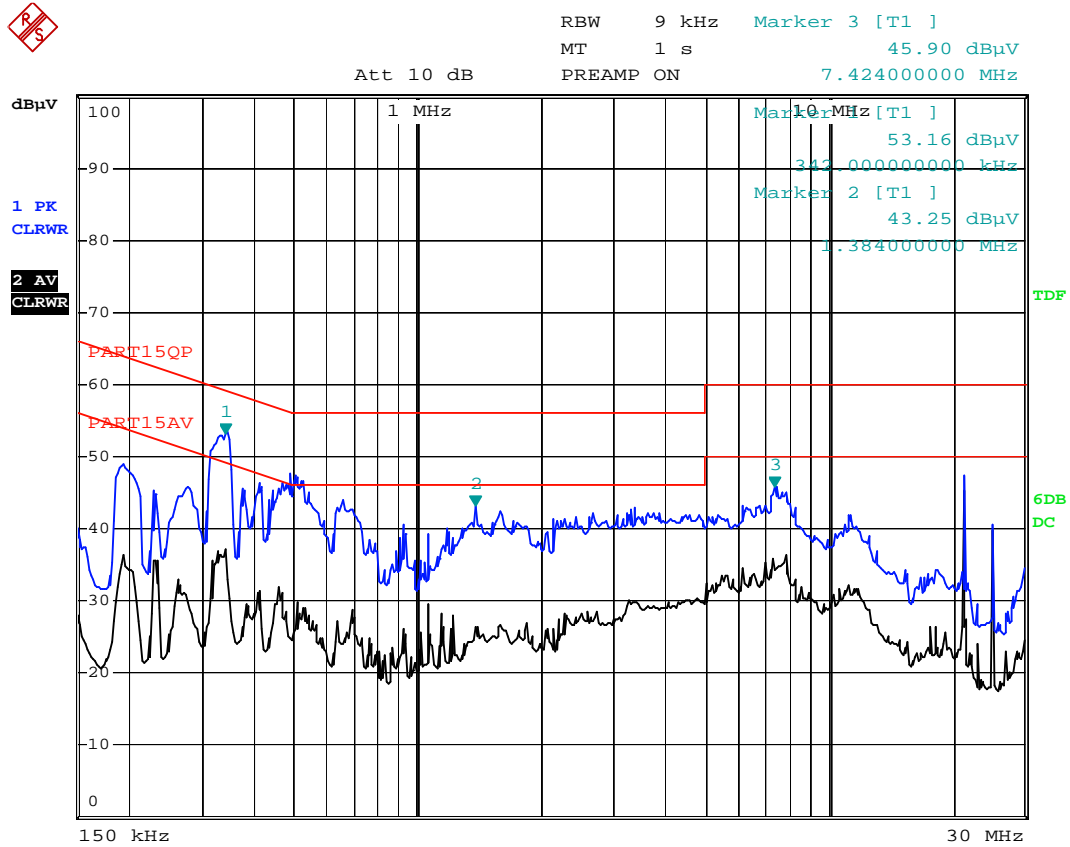

ELAMMD-N

Date: 19.SEP.2009 11:18:41

7. FCC RADIATED EMISSION TEST

7.1. TEST EQUIPMENT OF RADIATED EMISSION

Description	Manufacturer	Model	SERIAL NUMBER	Cal. Date	Cal. Due
EMI test receiver	R&S.	ESCS30	100343	04/16/2009	04/15/2010
Amplifier	H.P.	HP8447E	2945A02715	04/16/2009	04/15/2010
Antenna	Sunol Sciences Corp.	JB3	A021907	04/16/2009	04/15/2010
Spectrum	Analyzer	Agilent	E4440A	04/16/2009	04/15/2010

7.2. LIMITS OF RADIATED EMISSION TEST

Frequency (MHz)	Distance (m)	Maximum Field Strength Limit (dBuV/m/ Q.P.)
30~88	3	40.0
88~216	3	43.5
216~960	3	46.0
Above 960	3	54.0

**Note: The lower limit shall apply at the transition frequency.

7.3 BLOCK DIAGRAM OF RADIATED EMISSION TEST

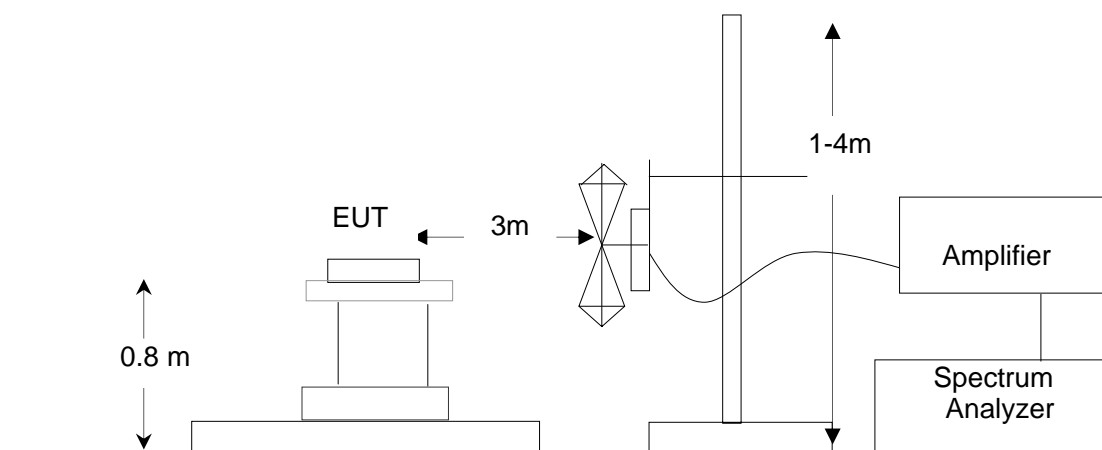

7.4 PROCEDURE OF RADIATED EMISSION TEST

- 1) The equipment was set up as per the test configuration to simulate typical actual usage per the user's manual. When the EUT is a tabletop system, a wooden turntable with a height of 0.8 meters is used which is placed on the ground plane as per ANSI C63.4 (see Test Facility for the dimensions of the ground plane used). When the EUT is floor-standing equipment, it is placed on the ground plane which has a 3-12 mm non-conductive covering to insulate the EUT from the ground plane.
- 2) Support equipment, if needed, was placed as per ANSI C63.4.
- 3) All I/O cables were positioned to simulate typical actual usage as per ANSI C63.4.
- 4) The EUT received DC 16V by adapter. All support equipments received AC 120V/60Hz power from socket under the turntable, if any.
- 5) The antenna was placed at 3 meter away from the EUT as stated in FCC Part 15. The antenna connected to the Analyzer via a cable and at times a pre-amplifier would be used.
- 6) The Analyzer / Receiver quickly scanned from 30MHz to 2000MHz. The EUT test program was started. Emissions were scanned and measured rotating the EUT to 360 degrees and positioning the antenna 1 to 4 meters above the ground plane, in both the vertical and the horizontal polarization, to maximize the emission reading level.
- 7) The test mode(s) were scanned during the test:
- 8) Recorded at least the six highest emissions. Emission frequency, amplitude, antenna position, polarization and turntable position were recorded into a computer in which correction factors were used to calculate the emission level and compare reading to the applicable limit and Q.P./Peak reading is presented.

The test data of the worst case condition(s) was reported on the Summary Data page.

7.5 TEST RESULT OF RADIATED EMISSION TEST

TEST RESULT OF RADIATED EMISSION - HORIZONTAL

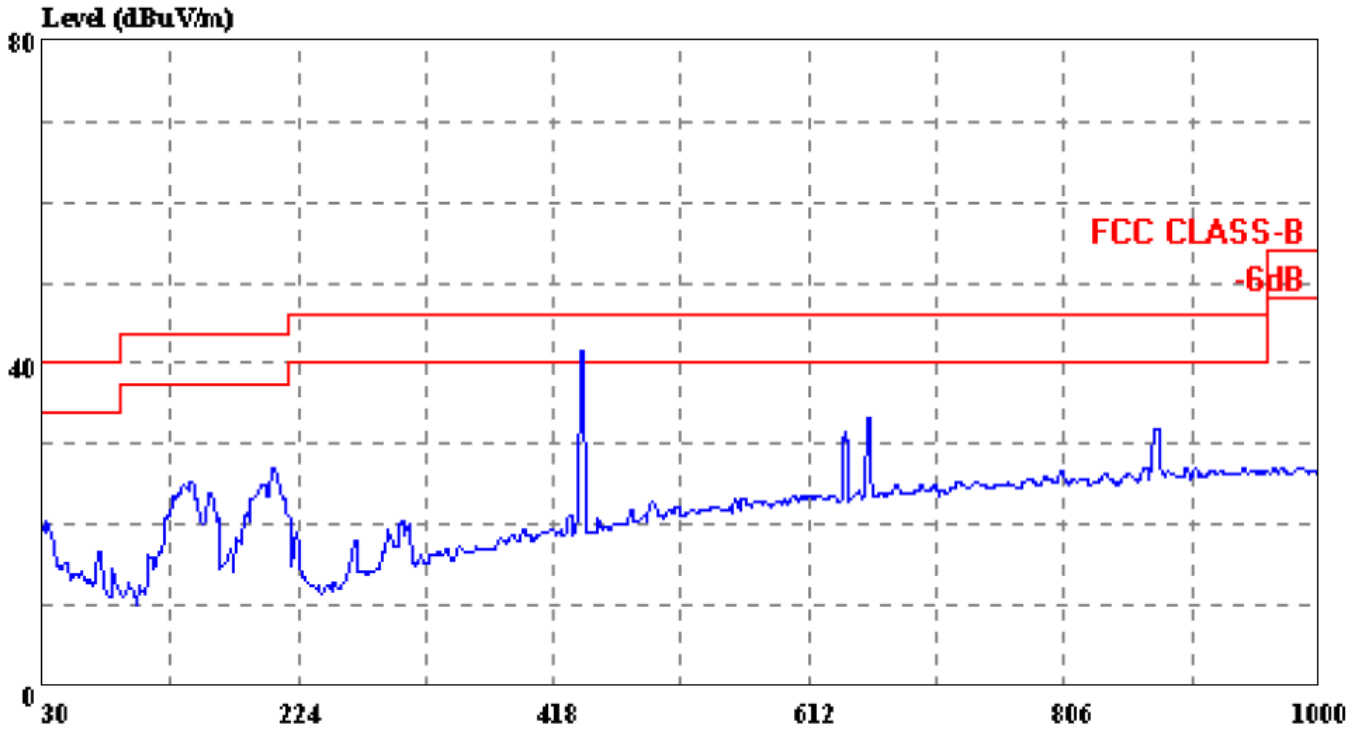

TEST RESULT OF RADIATED EMISSION - VERTICAL

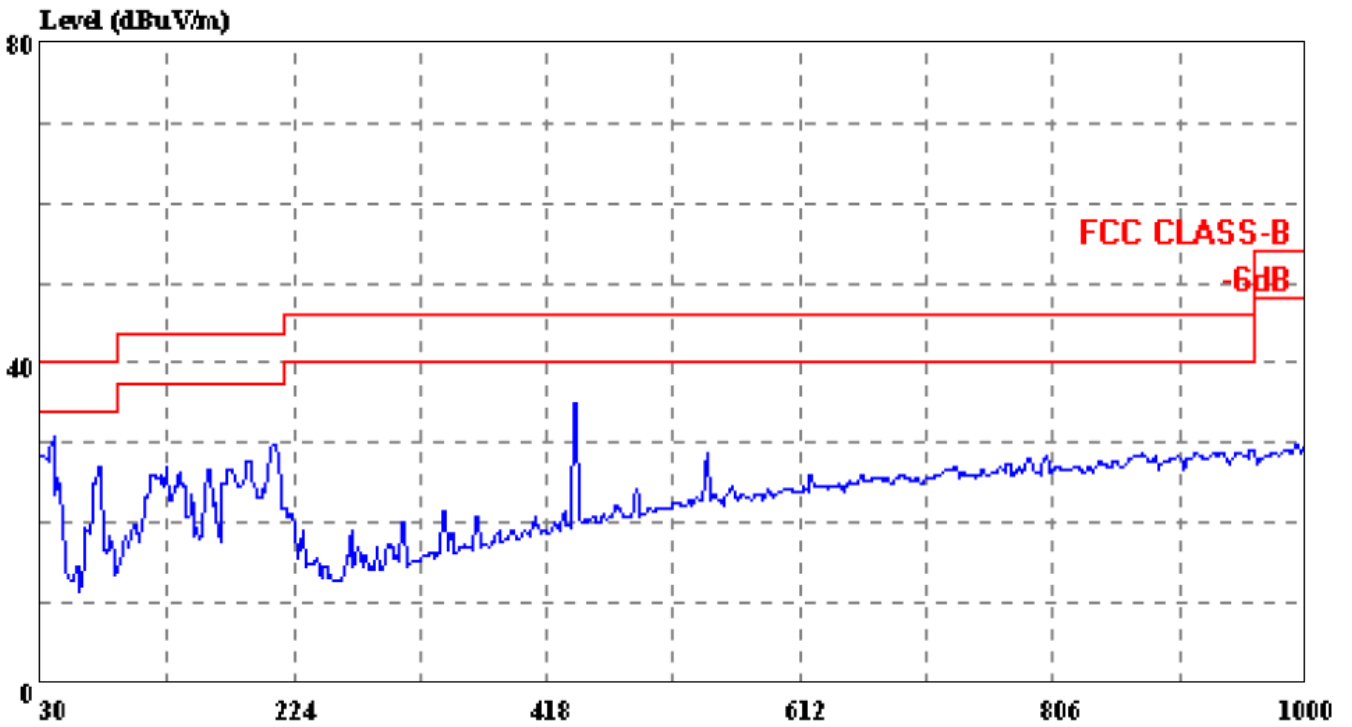

TEST RESULT OF RADIATED EMISSION (1GHZ TO 2GHZ)

RESULTS:

Freq.	Antenna	Reading	Total Factor	Radaiated	Limit	Margin	State
(MHz)	Polarity	(dBuV/m)	(dB)	(dBuV/m)	(dBuV/m)	(dB)	P/F
1308.000	H	27.92	16.49	44.41	54	-9.59	PASS
1553.000	H	28.55	17.89	46.44	54	-7.56	PASS
--	H	--	--	--	--	--	PASS
2000.000	H	--	--	--	--	--	PASS
1205.000	V	27.91	16.41	44.32	54	-9.68	PASS
1725.000	V	28.24	18.12	46.36	54	-7.64	PASS
--	V	--	--	--	--	--	PASS
2000.000	V	--	--	--	--	--	PASS

Note:

“-” indicate the test value is much lower to limit

APPENDIX 1
PHOTOGRAPHS OF TEST SETUP
FCC LINE CONDUCTED EMISSION TEST SETUP



FCC RADIATED EMISSION TEST SETUP

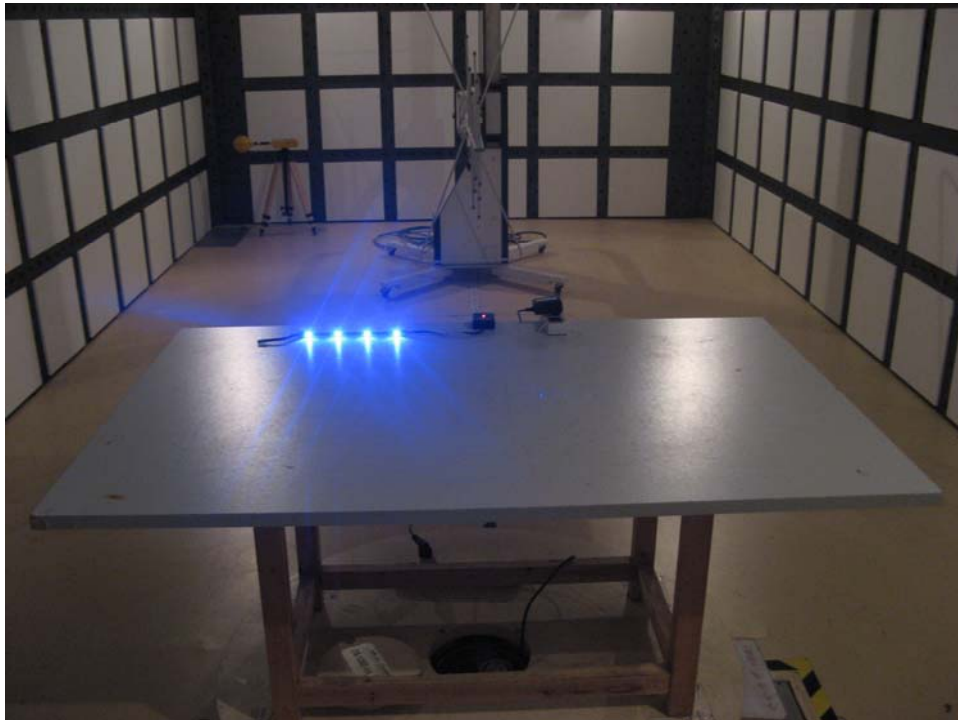

APPENDIX 2 PHOTOGRAPHS OF EUT

ALL VIEW OF EUT



FRONT VIEW OF EUT



BACK VIEW OF EUT



LEFT VIEW OF EUT



RIGHT VIEW OF EUT



UP VIEW OF EUT



DOWN VIEW OF EUT



INTERNAL VIEW OF EUT – 1

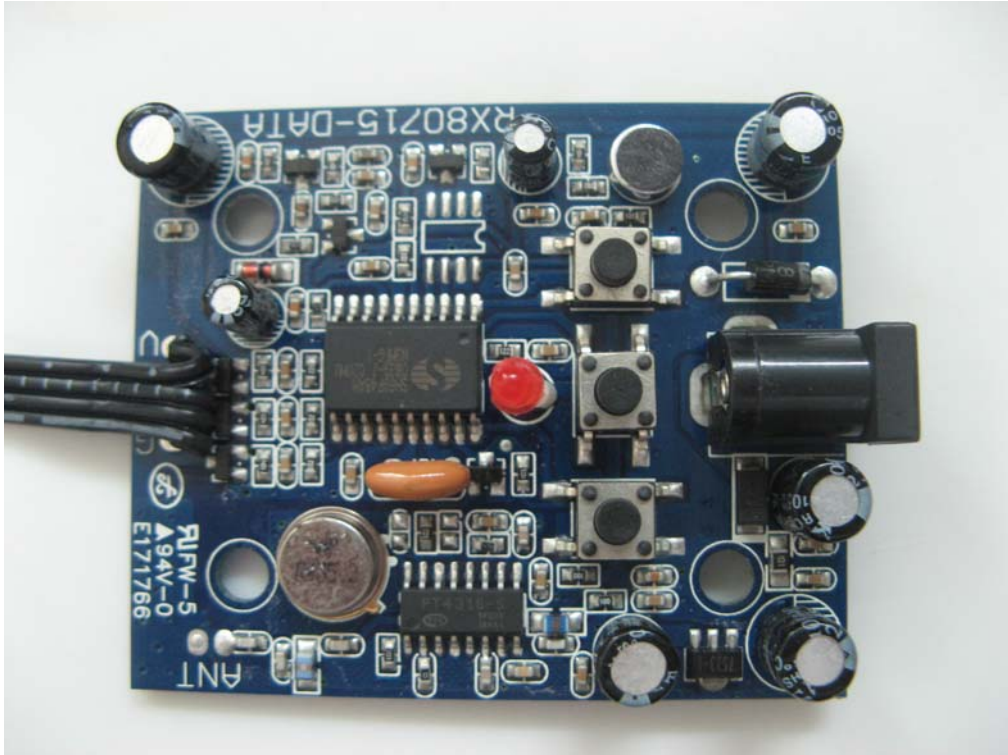

INTERNAL VIEW OF EUT – 2

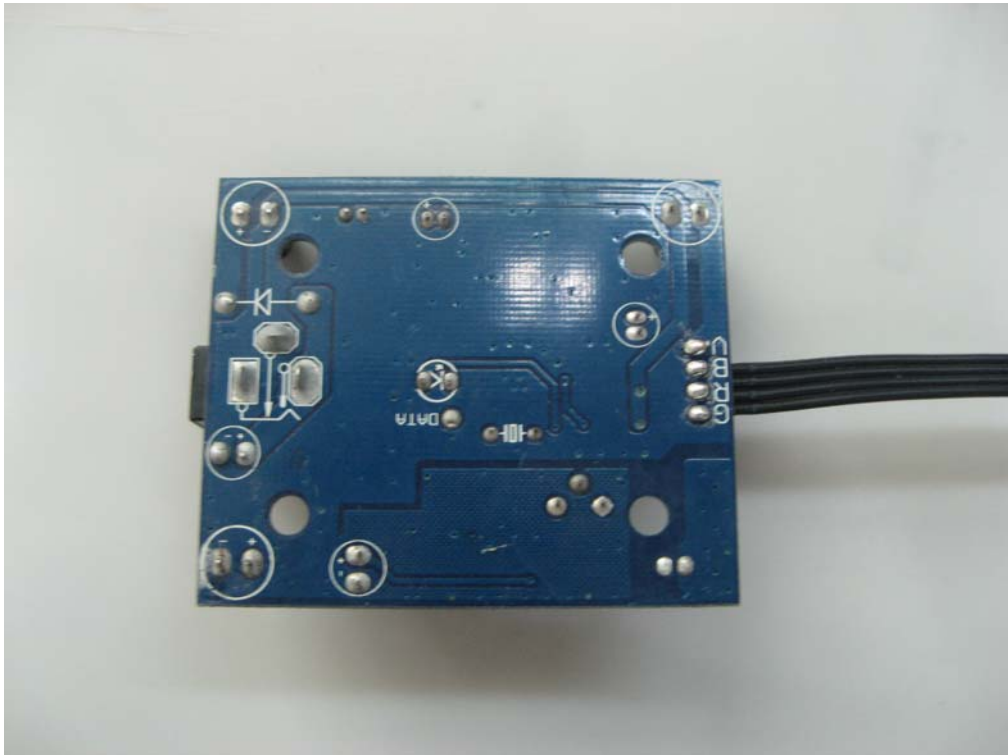

---END OF REPORT---