

FCC TEST REPORT
for
Elexa Consumer Products Inc.

Dome Hub
Model No.: DMGW1

Prepared for : Elexa Consumer Products Inc.
Address : 2275 Half Day Road, Suite 333, Bannockburn, Illinois, 60015,
United States

Prepared By : Shenzhen Anbotek Compliance Laboratory Limited
Address : 1/F., Building 1, SEC Industrial Park, No.0409 Qianhai Road,
Nanshan District, Shenzhen, Guangdong, China
Tel: (86) 755-26066544
Fax: (86) 755-26014772

Report Number : R011605225Z
Date of Test : May 12~ Jun. 03, 2016
Date of Report : Jun. 03, 2016

TABLE OF CONTENT

Description

Page

Test Report

1. GENERAL INFORMATION.....	4
1.1. Description of Device (EUT).....	4
1.2. Auxiliary Equipment Used during Test.....	5
1.3. Description of Test Facility.....	5
1.4. Measurement Uncertainty.....	5
2. TEST METHODOLOGY.....	6
2.1. Summary of Test Results.....	6
2.2. Description of Test Modes.....	6
2.3. List of channels:.....	7
3. CONDUCTED EMISSION TEST.....	8
3.1. Block Diagram of Test Setup.....	8
3.2. Power Line Conducted Emission Measurement Limits (15.207).....	8
3.3. Configuration of EUT on Measurement.....	8
3.4. Operating Condition of EUT.....	8
3.5. Test Procedure.....	9
3.6. Test equipment.....	9
3.7. Power Line Conducted Emission Measurement Results.....	9
4. FCC Part 15.247 Requirements for DSSS & OFDM Modulation.....	14
4.1 Test Setup.....	14
4.2 6dB Bandwidth.....	14
4.3. Maximum Output Power Test.....	28
4.4. Band Edges Measurement.....	36
4.5. Peak Power Spectral Density.....	106
4.6. Radiated Emissions.....	114
5. ANTENNA APPLICATION.....	131
5.1. Antenna requirement.....	131
4.2. Result.....	131
6. PHOTOGRAPH.....	132
6.1. Photo of Conducted Emission Measurement.....	132
6.2. Photo of Radiation Emission Test.....	132
APPENDIX I (EXTERNAL PHOTOS).....	134
APPENDIX II (INTERNAL PHOTOS).....	138

TEST REPORT

Applicant : Elexa Consumer Products Inc.
Manufacturer : Ubitech Limited
EUT : Dome Hub
Model No. : DMGW1
Serial No. : N.A.
Trade Mark : N.A.
Rating : DC 9V, 1.3A

Measurement Procedure Used:
FCC Part15 Subpart C 2015, Paragraph 15.247

The device described above is tested by Shenzhen Anbotek Compliance Laboratory Limited to determine the maximum emission levels emanating from the device and the severe levels of the device can endure and its performance criterion. The measurement results are contained in this test report and Shenzhen Anbotek Compliance Laboratory Limited is assumed full of responsibility for the accuracy and completeness of these measurements. Also, this report shows that the EUT (Equipment Under Test) is technically compliant with the FCC Part 15 Subpart C requirements.

This report applies to above tested sample only and shall not be reproduced in part without written approval of Shenzhen Anbotek Compliance Laboratory Limited.

Date of Test : May 12~ Jun. 03, 2016

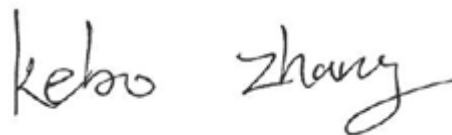
Prepared by : 
(Tested Engineer / Kebo Zhang)

Reviewer : 
(Project Manager / Amy Ding)

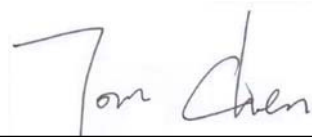
Approved & Authorized Signer : 
(Manager / Tom Chen)

1. GENERAL INFORMATION

1.1. Description of Device (EUT)

EUT	: Dome Hub
Model Number	: DMGW1
Test Power Supply	: AC 120V, 60Hz for adapter (with DC6V battery inside) AC 240V, 50Hz for adapter (with DC6V battery inside)
Adapter	: Model: ASSA55A-090130 Input: 100-240V~, 50/60Hz, 0.45A Output: DC 9V, 1.3A
RF Transmission Frequency	: 2412MHz~2462MHz (802.11b/802.11g/802.11n(HT20)) 2422MHz~2452MHz (802.11n(HT40)) 908.4MHz, 916MHz
Channels	: 11 For (802.11b/802.11g/802.11n(HT20)) 7 For (802.11n(HT40)) 2 For (908.4MHz, 916MHz)
Modulation	: 802.11b CCK; 802.11g OFDM; 802.11n MCS ASK (908.4MHz, 916MHz)
Antenna Gain:	: 0 dBi for WIFI (ANT A, ANT B) 0 dBi For (908.4MHz, 916MHz)
Applicant Address	: Elexa Consumer Products Inc. 2275 Half Day Road, Suite 333, Bannockburn, Illinois, 60015, United States
Manufacturer Address	: Ubitech Limited Unit 5, 5/F, Mega Trade Centre, 1 Mei Wan Street, Tsuen Wan, NT, Hong Kong
Factory Address	: Shenzhen Yu Yang Sheng Technology Co., Ltd. 2F, Building 10, Changxing Technology Park, Wan'an Road, Shajing Street, Baoan District, Shenzhen, China
Date of receipt	: May 12, 2016
Date of Test	: May 12~ Jun. 03, 2016

1.2. Auxiliary Equipment Used during Test

Notebook : Manufacturer: LIFE BOOK
Model: LH531
CE, FCC DOC

Printer : Manufacturer: Brother
M/N: MFC-3360C
S/N: N/A
CE, FCC: DOC

1.3. Description of Test Facility

The test facility is recognized, certified, or accredited by the following organizations:

FCC-Registration No.: 752021

Shenzhen Anbotek Compliance Laboratory Limited, EMC Laboratory has been registered and fully described in a report filed with the (FCC) Federal Communications Commission. The acceptance letter from the FCC is maintained in our files. Registration 752021, July 10, 2013.

IC-Registration No.: 8058A-1

Shenzhen Anbotek Compliance Laboratory Limited., EMC Laboratory has been registered and fully described in a report filed with the (IC) Industry Canada. The acceptance letter from the IC is maintained in our files. Registration 8058A-1, Jun. 13, 2016.

Test Location

All Emissions tests were performed at
Shenzhen Anbotek Compliance Laboratory Limited. at 1/F., Building 1, SEC Industrial Park, No.0409 Qianhai Road, Nanshan District, Shenzhen, Guangdong, China

1.4. Measurement Uncertainty

Radiation Uncertainty : Ur = 4.1 dB (Horizontal)
Ur = 4.3 dB (Vertical)

Conduction Uncertainty : Uc = 3.4dB

2. TEST METHODOLOGY

The tests documented in this report were performed in accordance with ANSI C63.10: 2013 and FCC Part 15, Paragraph 15.247.

2.1. Summary of Test Results

The EUT has been tested according to the following specifications:

Standard	Test Type	Result	Notes
FCC Part 15, Paragraph 15.107, 15.207	Conducted Emission Test	PASS	Complies
FCC Part 15, Paragraph 15.247(b)(1)	Maximum Output Power	PASS	Complies
FCC Part 15, Paragraph 15.247(a)(2)	6dB Bandwidth	PASS	Complies
FCC Part 15, Paragraph 15.247(c)	100kHz Bandwidth of Frequency Band Edges	PASS	Complies
FCC Part 15, Paragraph 15.209(a)(f)	Spurious Emission	PASS	Complies
FCC Part 15, Paragraph 15.247(a)(1)	Frequency Separation	-	N/A
FCC Part 15, Paragraph 15.247(a)(1)(iii)	Number of Hopping Frequency	-	N/A
FCC Part 15, Paragraph 15.247(a)(1)(iii)	Time of Occupancy	-	N/A
FCC Part 15, Paragraph 15.247(c)	Peak Power Density	PASS	Complies

2.2. Description of Test Modes

The EUT has been tested under operating condition.

Software used to control the EUT for staying in continuous transmitting and receiving mode is programmed.

IEEE802.11b: Channel 1(2412MHz), Channel 6(2437MHz) and Channel 11(2462MHz) with 1 Mbps lowest data rate (worst case) are chosen for the final testing.

IEEE802.11g: Channel 1(2412MHz), Channel 6(2437MHz) and Channel 11(2462MHz) with 6 Mbps lowest data rate (the worst case) are chosen for the final testing.

IEEE802.11n (HT20): Channel 1(2412MHz), Channel 6(2437MHz) and Channel 11(2462MHz) with MCS 0 Mbps lowest data rate (the worst case) are chosen for the final testing.

IEEE802.11n (HT40): Channel 3(2422MHz), Channel 6(2437MHz) and Channel 9(2452MHz) with MCS 0 Mbps lowest data rate (the worst case) are chosen for the final testing.

2.3. List of channels:

√ - available

X - tested

Number	Frequency(MHz)		802.11 b/g/n (HT20)	802.11 b/g/n (HT40)
1	2412	√	X	
2	2417	√		
3	2422	√		X
4	2427	√		
5	2432	√		
6	2437	√	X	X
7	2442	√		
8	2447	√		
9	2452	√		X
10	2457	√		
11	2462	√	X	

3. Conducted Emission Test

3.1. Block Diagram of Test Setup

3.1.1. Block diagram of connection between the EUT and simulators

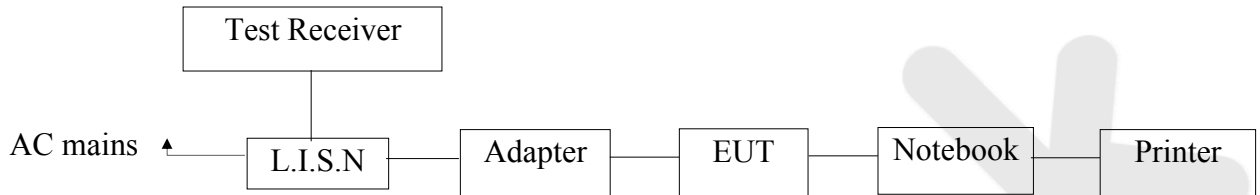

3.2. Power Line Conducted Emission Measurement Limits (15.207)

Frequency MHz	Limits dB(μV)	
	Quasi-peak Level	Average Level
0.15 ~ 0.50	66 ~ 56*	56 ~ 46*
0.50 ~ 5.00	56	46
5.00 ~ 30.00	60	50

- Notes: 1. *Decreasing linearly with logarithm of frequency.
2. The lower limit shall apply at the transition frequencies.

3.3. Configuration of EUT on Measurement

The following equipments are installed on Power Line Conducted Emission Measurement to meet the commission requirement and operating regulations in a manner which tends to maximize its emission characteristics in a normal application.

3.4. Operating Condition of EUT

- 3.4.1. Setup the EUT and simulator as shown as Section 3.1.
- 3.4.2. Turn on the power of all equipment.
- 3.4.3. Let the EUT work in test mode (WAN Mode) and measure it.

3.5. Test Procedure

The EUT system is connected to the power mains through a line impedance stabilization network (L.I.S.N.). This provides a 50ohm coupling impedance for the EUT system. Please refer the block diagram of the test setup and photographs. Both sides of AC line are checked to find out the maximum conducted emission. In order to find the maximum emission levels, the relative positions of equipment and all of the interface cables shall be changed according to FCC ANSI C63.10-2013 on Conducted Emission Measurement.

The bandwidth of test receiver (ESCI) set at 9KHz.

The frequency range from 150KHz to 30MHz is checked.

The test results are reported on Section 3.6.

3.6. Test equipment

Item	Equipment	Manufacturer	Model No.	Serial No.	Last Cal.	Cal. Interval
1.	Two-Line V-network	Rohde & Schwarz	ENV216	100055	Apr. 17, 2016	1 Year
2.	EMI Test Receiver	Rohde & Schwarz	ESCI	100627	Apr. 17, 2016	1 Year
3.	RF Switching Unit	Compliance Direction	RSU-M2	38303	Apr. 17, 2016	1 Year

3.7. Power Line Conducted Emission Measurement Results

PASS.

The frequency range from 150KHz to 30 MHz is investigated.

Please refer the following pages.

CONDUCTED EMISSION TEST DATA

Test Site: 1# Shielded Room
 Operating Condition: WAN Mode
 Test Specification: AC 120V, 60Hz for adapter
 Comment: Live Line
 Tem.:24°C Hum.:49%

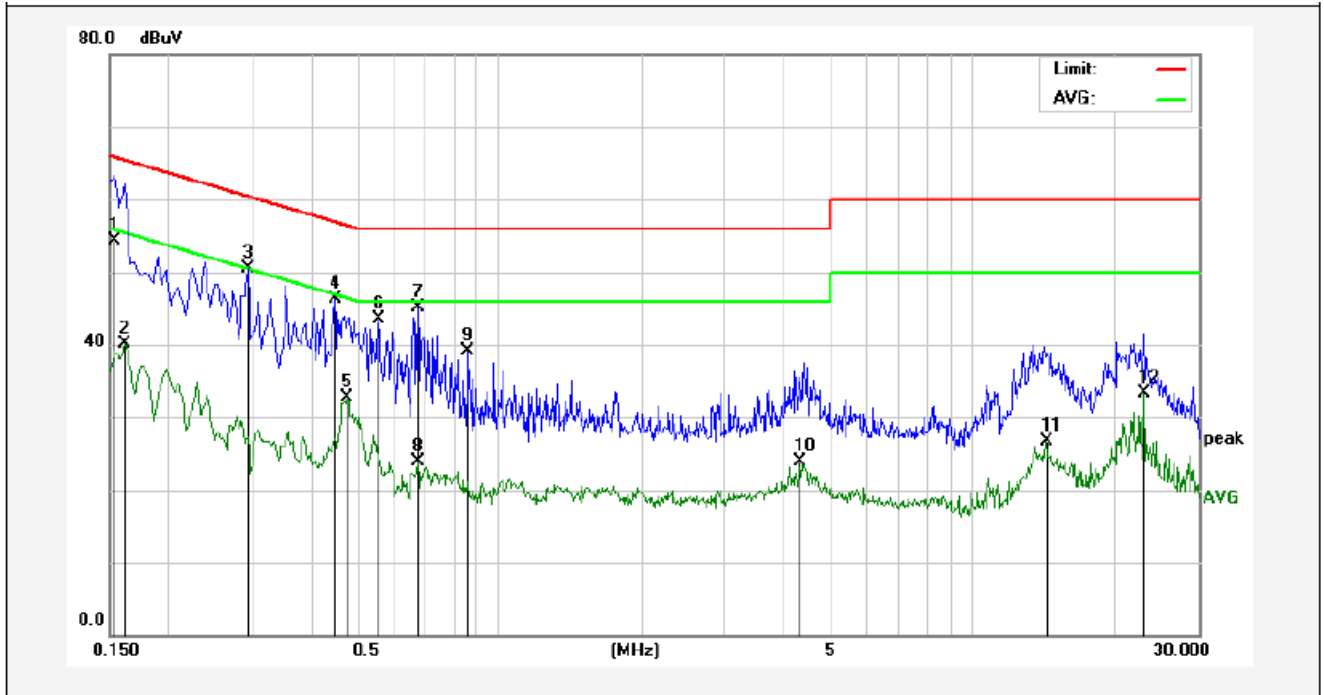

No.	Freq. (MHz)	Reading (dBuV)	Factor (dB)	Result (dBuV)	Limit dBuV	Over Limit (dB)	Detector	Remark
1	0.1539	34.37	20.00	54.37	65.78	-11.41	QP	
2	0.1620	20.15	20.00	40.15	55.36	-15.21	AVG	
3	0.2940	30.44	20.00	50.44	60.41	-9.97	QP	
4	0.4500	26.22	20.00	46.22	56.87	-10.65	QP	
5	0.4780	12.74	20.00	32.74	46.37	-13.63	AVG	
6	0.5580	23.55	20.00	43.55	56.00	-12.45	QP	
7	0.6740	25.09	20.00	45.09	56.00	-10.91	QP	
8	0.6740	3.89	20.00	23.89	46.00	-22.11	AVG	
9	0.8580	19.05	20.00	39.05	56.00	-16.95	QP	
10	4.3140	3.86	20.00	23.86	46.00	-22.14	AVG	
11	14.2140	6.79	20.00	26.79	50.00	-23.21	AVG	
12	23.1299	13.33	20.00	33.33	50.00	-16.67	AVG	

CONDUCTED EMISSION TEST DATA

Test Site:	1# Shielded Room
Operating Condition:	WAN Mode
Test Specification:	AC 120V, 60Hz for adapter
Comment:	Neutral Line
	Tem.:24°C Hum.:49%

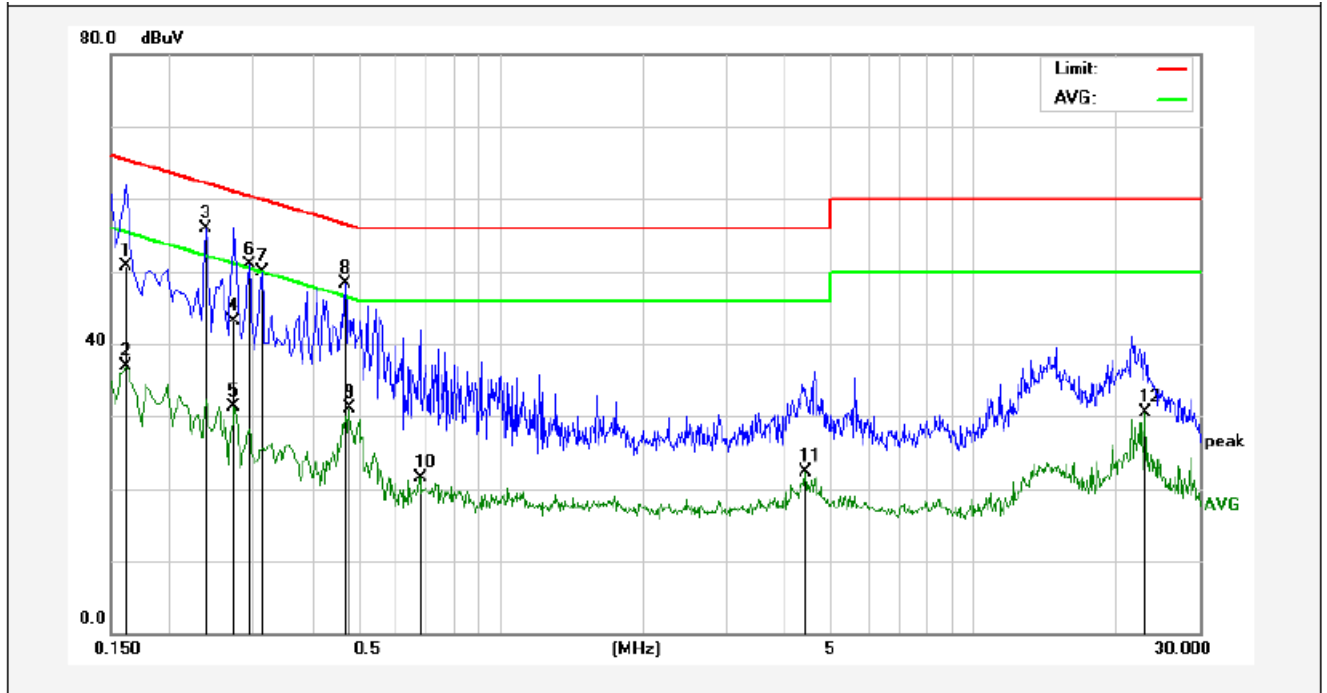

No.	Freq. (MHz)	Reading (dBuV)	Factor (dB)	Result (dBuV)	Limit dBuV	Over Limit (dB)	Detector	Remark
1	0.1620	30.69	20.00	50.69	65.36	-14.67	QP	
2	0.1620	16.98	20.00	36.98	55.36	-18.38	AVG	
3	0.2380	35.98	20.00	55.98	62.16	-6.18	QP	
4	0.2740	23.18	20.00	43.18	60.99	-17.81	QP	
5	0.2740	11.38	20.00	31.38	50.99	-19.61	AVG	
6	0.2940	30.82	20.00	50.82	60.41	-9.59	QP	
7	0.3140	29.84	20.00	49.84	59.86	-10.02	QP	
8	0.4700	28.24	20.00	48.24	56.51	-8.27	QP	
9	0.4780	11.01	20.00	31.01	46.37	-15.36	AVG	
10	0.6780	1.51	20.00	21.51	46.00	-24.49	AVG	
11	4.4220	2.26	20.00	22.26	46.00	-23.74	AVG	
12	23.1299	10.54	20.00	30.54	50.00	-19.46	AVG	

CONDUCTED EMISSION TEST DATA

Test Site: 1# Shielded Room
 Operating Condition: WAN Mode
 Test Specification: AC 240V, 60Hz for adapter
 Comment: Live Line
 Tem.:24°C Hum.:49%

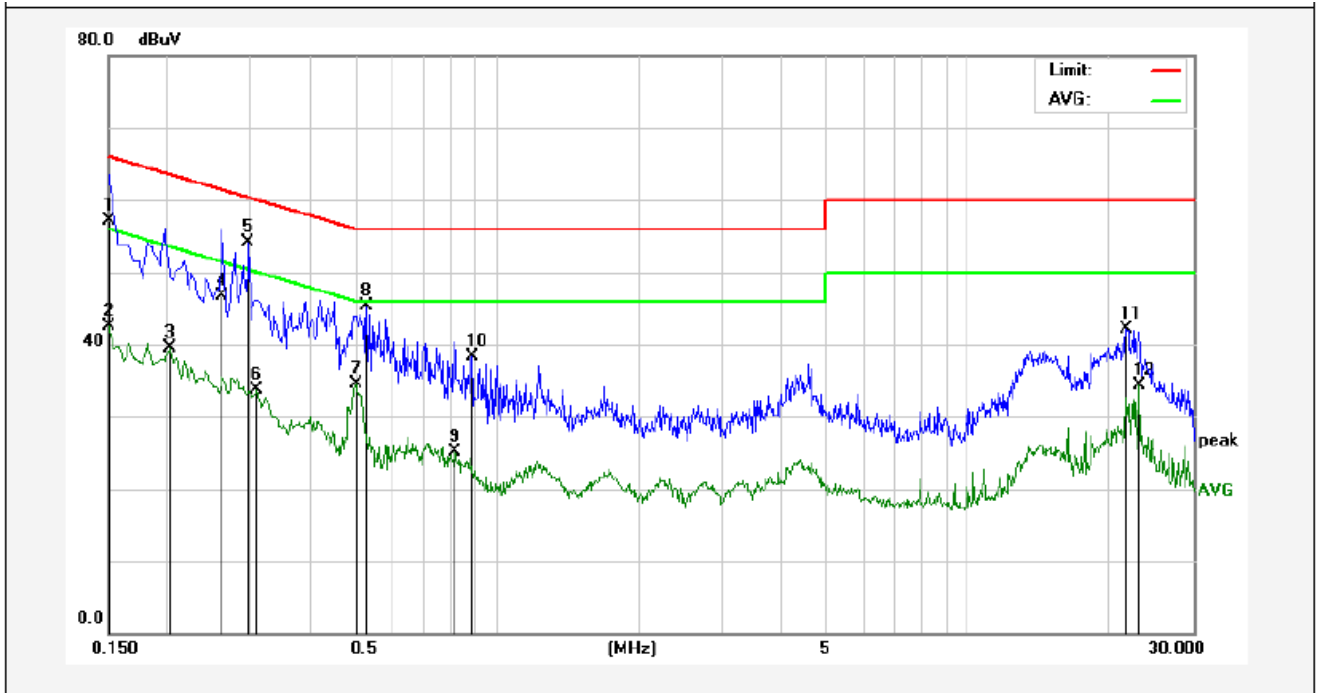

No.	Freq. (MHz)	Reading (dBuV)	Factor (dB)	Result (dBuV)	Limit dBuV	Over Limit (dB)	Detector	Remark
1	0.1500	37.08	20.00	57.08	65.99	-8.91	QP	
2	0.1500	22.46	20.00	42.46	55.99	-13.53	AVG	
3	0.2020	19.54	20.00	39.54	53.52	-13.98	AVG	
4	0.2620	26.62	20.00	46.62	61.36	-14.74	QP	
5	0.2980	34.12	20.00	54.12	60.30	-6.18	QP	
6	0.3100	13.68	20.00	33.68	49.97	-16.29	AVG	
7	0.5020	14.54	20.00	34.54	46.00	-11.46	AVG	
8	0.5299	25.33	20.00	45.33	56.00	-10.67	QP	
9	0.8139	5.15	20.00	25.15	46.00	-20.85	AVG	
10	0.8860	18.21	20.00	38.21	56.00	-17.79	QP	
11	21.6660	22.16	20.00	42.16	60.00	-17.84	QP	
12	23.1299	14.23	20.00	34.23	50.00	-15.77	AVG	

CONDUCTED EMISSION TEST DATA

Test Site: 1# Shielded Room
 Operating Condition: WAN Mode
 Test Specification: AC 240V, 60Hz for adapter
 Comment: Neutral Line
 Tem.:24°C Hum.:49%

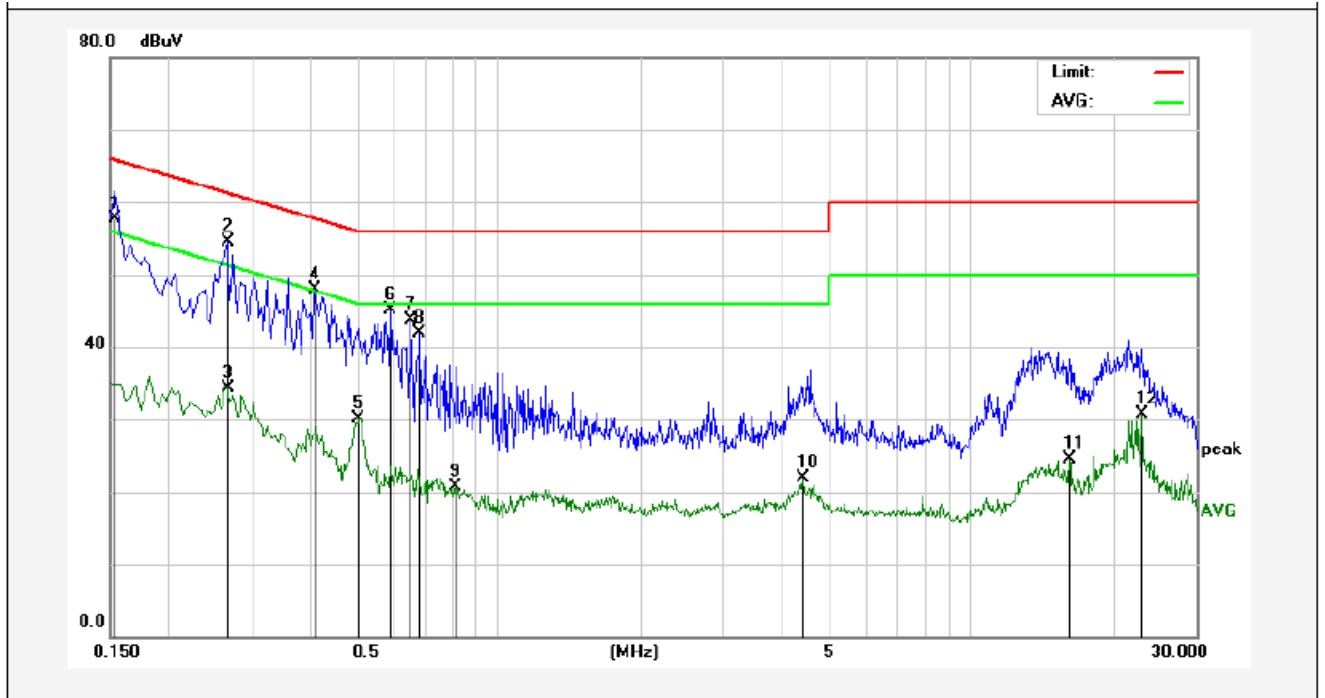

No.	Freq. (MHz)	Reading (dBuV)	Factor (dB)	Result (dBuV)	Limit dBuV	Over Limit (dB)	Detector	Remark
1	0.1539	37.69	20.00	57.69	65.78	-8.09	QP	
2	0.2660	34.60	20.00	54.60	61.24	-6.64	QP	
3	0.2660	14.30	20.00	34.30	51.24	-16.94	AVG	
4	0.4100	27.93	20.00	47.93	57.65	-9.72	QP	
5	0.5060	10.11	20.00	30.11	46.00	-15.89	AVG	
6	0.5899	25.15	20.00	45.15	56.00	-10.85	QP	
7	0.6540	23.62	20.00	43.62	56.00	-12.38	QP	
8	0.6820	21.92	20.00	41.92	56.00	-14.08	QP	
9	0.8100	0.64	20.00	20.64	46.00	-25.36	AVG	
10	4.4220	1.91	20.00	21.91	46.00	-24.09	AVG	
11	16.1660	4.52	20.00	24.52	50.00	-25.48	AVG	
12	23.1299	10.65	20.00	30.65	50.00	-19.35	AVG	

4. FCC Part 15.247 Requirements for DSSS & OFDM Modulation

4.1 Test Setup

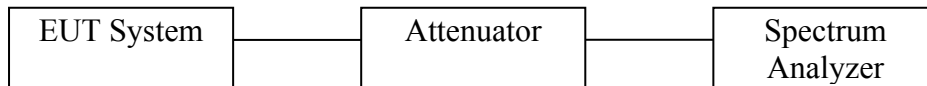

4.2 6dB Bandwidth

a. Limit

For the direct sequence systems, the minimum 6dB bandwidth shall be at least 500kHz.

b. Test Procedure

1. Place the EUT on the table and set it in the transmitting mode.
2. Remove the antenna from the EUT and then connect a low loss RF cable from the antenna port to the spectrum analyzer.
3. Set the spectrum analyzer as:
RBW = 100kHz, VBW $\geq 3 \times$ RBW = 300kHz,
Detector= Peak
Trace mode= Max hold.
Sweep- auto couple.
4. Mark the peak frequency and -6 dB (upper and lower) frequency.
5. Repeat until all the rest channels are investigated.

20dB Bandwidth:

C63.10

Occupied Bandwidth (OBW=20dB Bandwidth)

1. Set RBW=1%~5% OBW
2. Set the VBW $\geq 3 \times$ RBW
3. Set the span range between 2 times and 5 times of the OBW
4. Sweep Time= Auto
Detector= Peak
Trace= Max hold
5. Once the reference level is established, the equipment is conditioned with typical modulating signals to produce the worst case (i.e. the widest) bandwidth. Unless otherwise specified for an unlicensed wireless device, measure the bandwidth at the -20 dB levels with respect to the reference level.

c. Test Setup See 4.1

d. Test Equipment

Item	Equipment	Manufacturer	Model No.	Serial No.	Last Cal.	Cal. Interval
1.	Spectrum Analysis	Agilent	E4407B	US39390582	Apr. 17, 2016	1 Year
2.	Preamplifier	Instruments corporation	EMC011830	980100	Apr. 17, 2016	1 Year
3.	EMI Test Receiver	Rohde & Schwarz	ESPI	101604	Apr. 17, 2016	1 Year
4.	Double Ridged Horn Antenna	Instruments corporation	GTH-0118	351600	Apr. 20, 2016	1 Year
5.	Bilog Broadband Antenna	Schwarzbeck	VULB9163	VULB 9163-289	Apr. 20, 2016	1 Year
6.	Pre-amplifier	SONOMA	310N	186860	Apr. 17, 2016	1 Year
7.	EMI Test Software EZ-EMC	SHURPLE	N/A	N/A	N/A	N/A
8	Power Sensor	DAER	RPR3006W	15I00041SN046	Jun 30, 2015	1 Year
9	MXA Spectrum Analysis	Agilent	N9020A	MY51170037	Jun 30, 2015	1 Year
10	MXG RF Vector Signal Generator	Agilent	N5182A	MY48180656	Jun 30, 2015	1 Year
11	Signal Generator	Agilent	E4421B	MY41000743	Jun 30, 2015	1 Year
12	DC Power supply	IV	IV-8080	YQSB0096	Jun 30, 2015	1 Year
13	TEMP&HUMI PROGRAMMABLE CHAMBER	Bell Group	BE-THK-150M8	SE-0137	Mar 16, 2016	1 Year

e. Test Results

Pass.

f. Test Data
6dB Bandwidth

ANT A

Test mode: IEEE 802.11b

Channel	Frequency (MHz)	Bandwidth (MHz)	Limit (kHz)	Results
Low	2412	9.182	>500	Pass
Mid	2437	9.611		Pass
High	2462	9.182		Pass

Test mode: IEEE 802.11g

Channel	Frequency (MHz)	Bandwidth (MHz)	Limit (kHz)	Results
Low	2412	16.54	>500	Pass
Mid	2437	16.54		Pass
High	2462	16.54		Pass

Test mode: IEEE 802.11n (HT20)

Channel	Frequency (MHz)	Bandwidth (MHz)	Limit (kHz)	Results
Low	2412	17.72	>500	Pass
Mid	2437	17.71		Pass
High	2462	17.71		Pass

Test mode: IEEE 802.11n (HT40)

Channel	Frequency (MHz)	Bandwidth (MHz)	Limit (kHz)	Results
Low	2422	36.51	>500	Pass
Mid	2437	36.51		Pass
High	2452	36.50		Pass

Test Plots See the following page.

ANT B

Test mode: IEEE 802.11b

Channel	Frequency (MHz)	Bandwidth (MHz)	Limit (kHz)	Results
Low	2412	9.186		Pass
Mid	2437	9.625	>500	Pass
High	2462	9.186		Pass

Test mode: IEEE 802.11g

Channel	Frequency (MHz)	Bandwidth (MHz)	Limit (kHz)	Results
Low	2412	16.54		Pass
Mid	2437	16.52	>500	Pass
High	2462	16.56		Pass

Test mode: IEEE 802.11n (HT20)

Channel	Frequency (MHz)	Bandwidth (MHz)	Limit (kHz)	Results
Low	2412	17.71		Pass
Mid	2437	17.71	>500	Pass
High	2462	17.72		Pass

Test mode: IEEE 802.11n (HT40)

Channel	Frequency (MHz)	Bandwidth (MHz)	Limit (kHz)	Results
Low	2422	36.49		Pass
Mid	2437	36.51	>500	Pass
High	2452	36.52		Pass

Test Plots See the following page.

ANT A

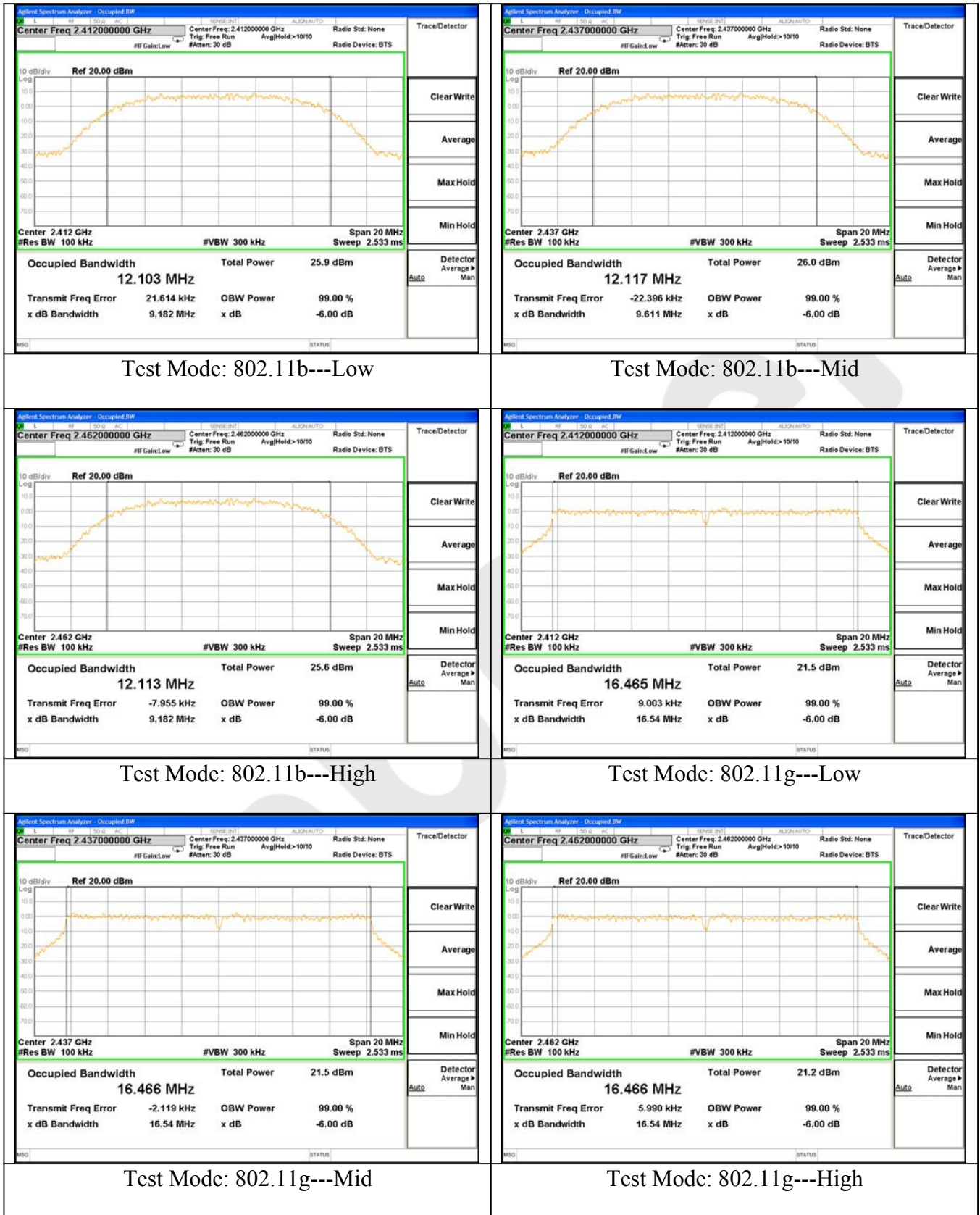

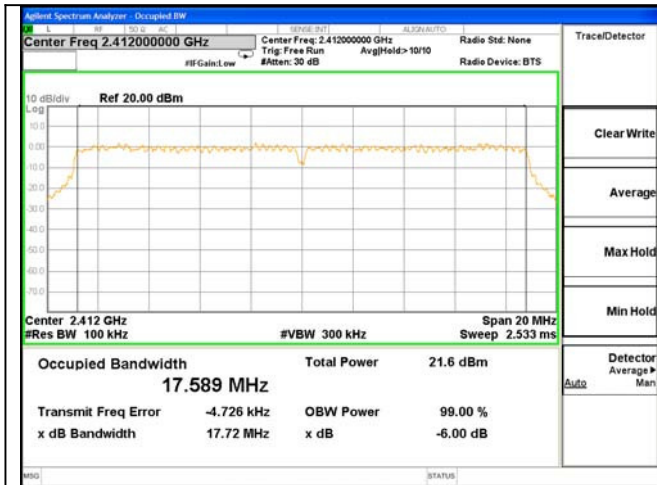

Test Mode: 802.11n20---Low

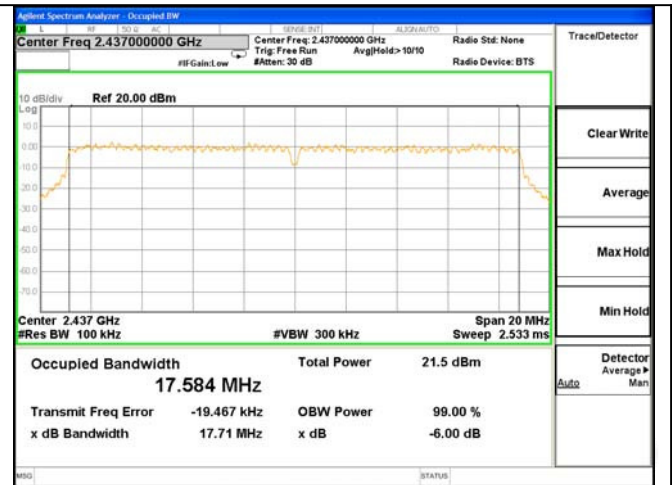

Test Mode: 802.11n20---Mid

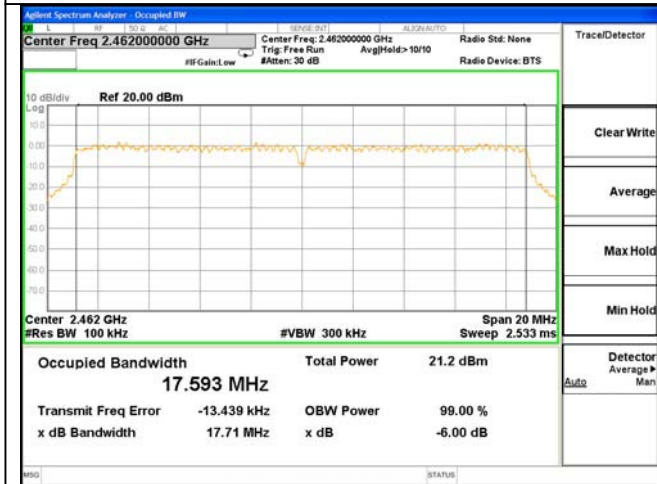

Test Mode: 802.11n20---High

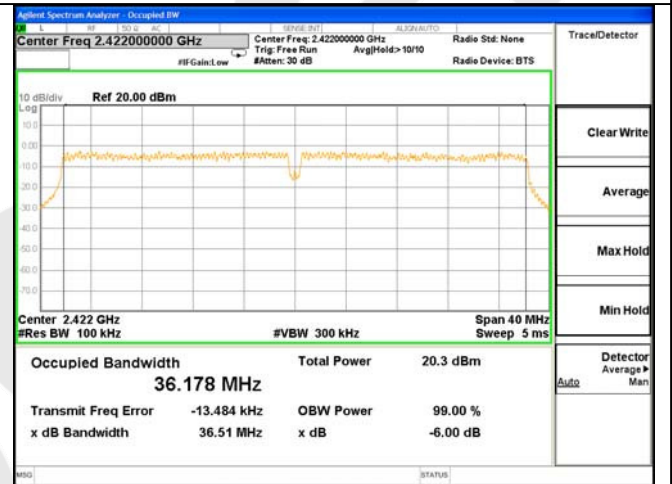

Test Mode: 802.11n40---Low

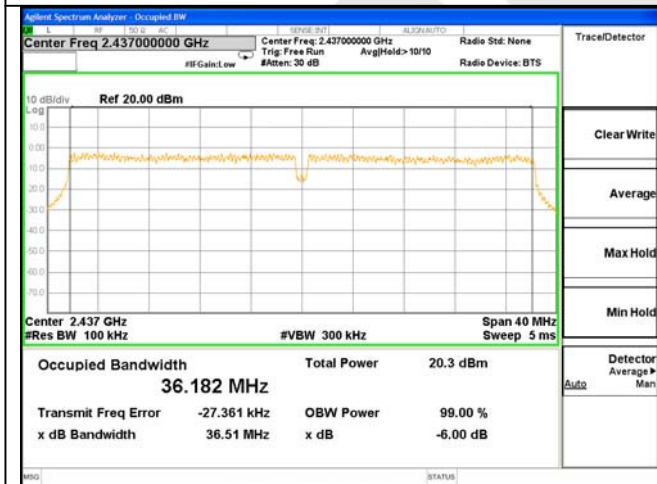

Test Mode: 802.11n40---Mid

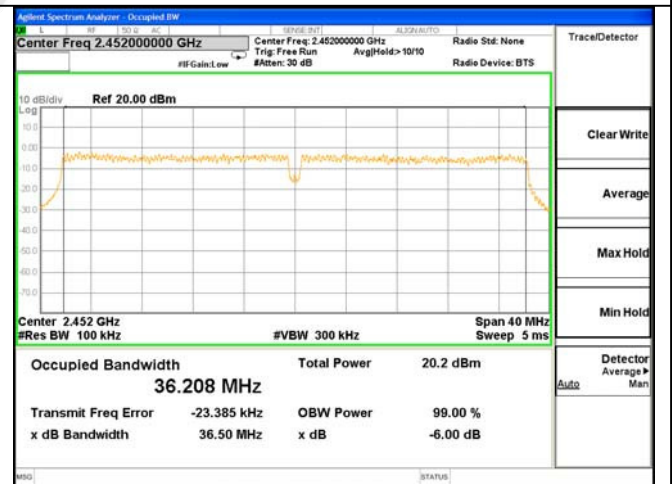

Test Mode: 802.11n40---High

ANT B

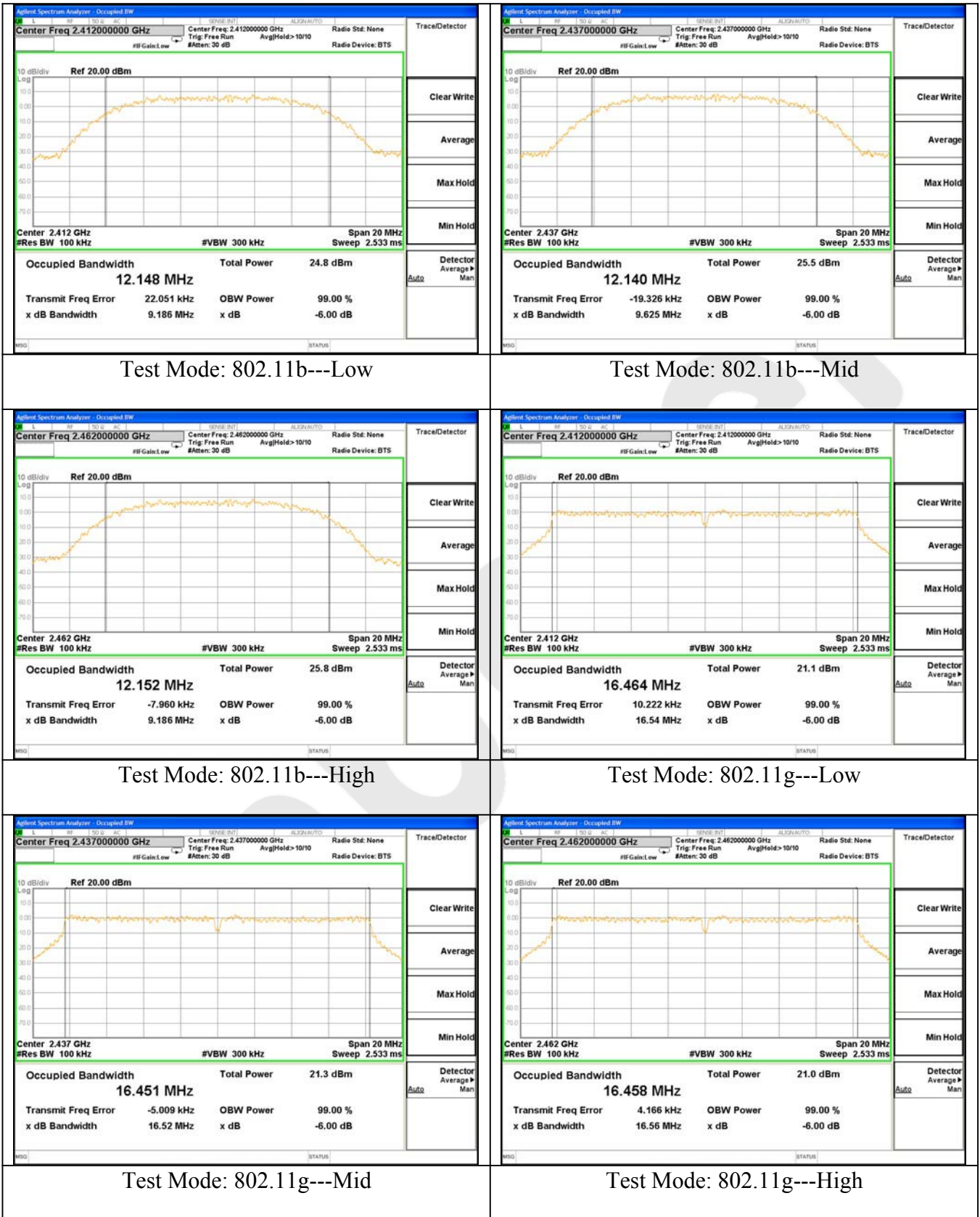



Test Mode: 802.11n20---Low

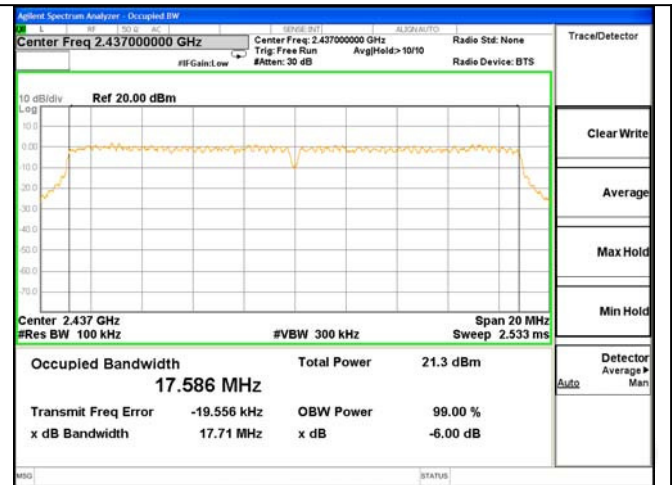

Test Mode: 802.11n20---Mid

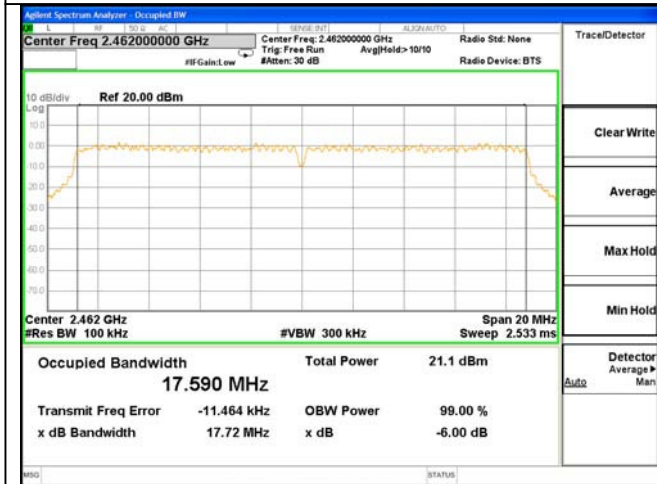

Test Mode: 802.11n20---High

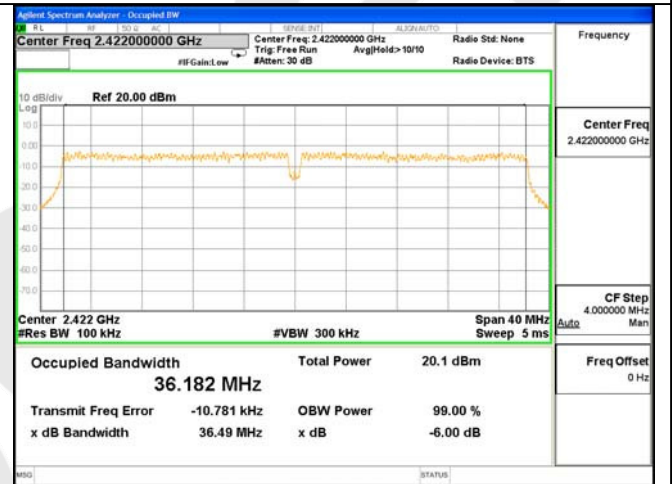

Test Mode: 802.11n40---Low

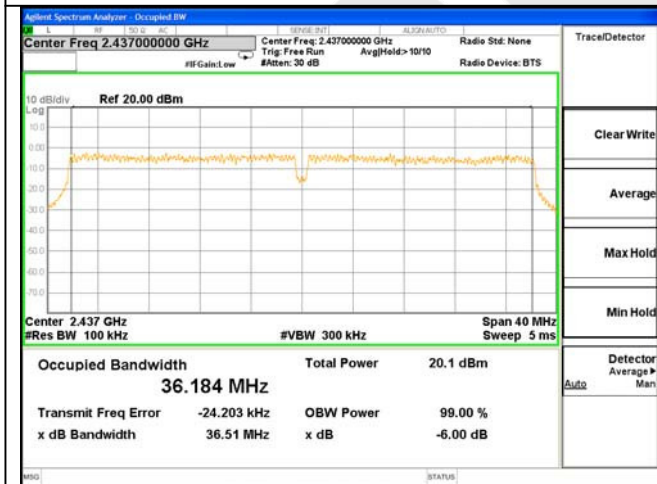

Test Mode: 802.11n40---Mid

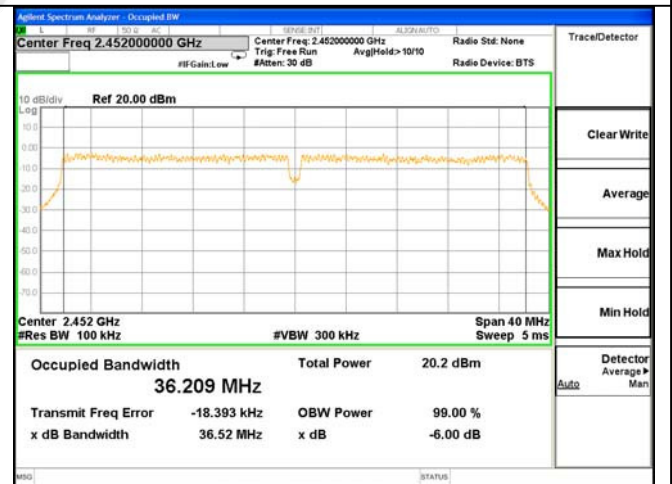

Test Mode: 802.11n40---High

20dB Bandwidth

ANT A

Test mode: IEEE 802.11b

Channel	Frequency (MHz)	Bandwidth (MHz)	Results
Low	2412	14.07	Pass
Mid	2437	14.09	Pass
High	2462	14.09	Pass

Test mode: IEEE 802.11g

Channel	Frequency (MHz)	Bandwidth (MHz)	Results
Low	2412	18.56	Pass
Mid	2437	18.53	Pass
High	2462	18.65	Pass

Test mode: IEEE 802.11n (HT20)

Channel	Frequency (MHz)	Bandwidth (MHz)	Results
Low	2412	19.19	Pass
Mid	2437	19.22	Pass
High	2462	19.12	Pass

Test mode: IEEE 802.11n (HT40)

Channel	Frequency (MHz)	Bandwidth (MHz)	Results
Low	2422	39.62	Pass
Mid	2437	40.22	Pass
High	2452	40.12	Pass

Test Plots See the following page.

ANT B

Test mode: IEEE 802.11b

Channel	Frequency (MHz)	Bandwidth (MHz)	Results
Low	2412	14.10	Pass
Mid	2437	14.10	Pass
High	2462	14.09	Pass

Test mode: IEEE 802.11g

Channel	Frequency (MHz)	Bandwidth (MHz)	Results
Low	2412	18.48	Pass
Mid	2437	18.48	Pass
High	2462	18.46	Pass

Test mode: IEEE 802.11n (HT20)

Channel	Frequency (MHz)	Bandwidth (MHz)	Results
Low	2412	19.03	Pass
Mid	2437	19.22	Pass
High	2462	19.17	Pass

Test mode: IEEE 802.11n (HT40)

Channel	Frequency (MHz)	Bandwidth (MHz)	Results
Low	2422	36.65	Pass
Mid	2437	39.80	Pass
High	2452	40.09	Pass

Test Plots See the following page.

ANT A

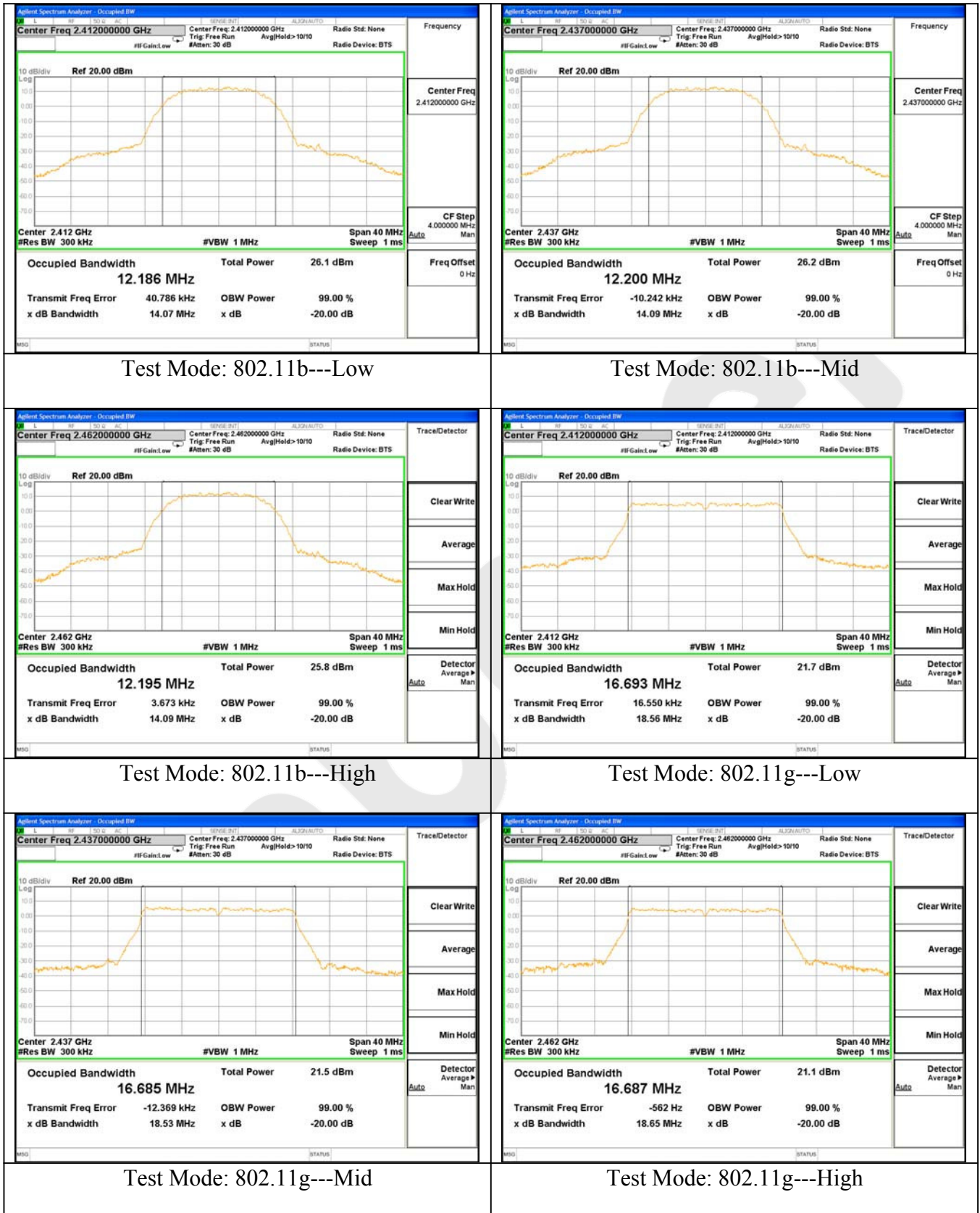

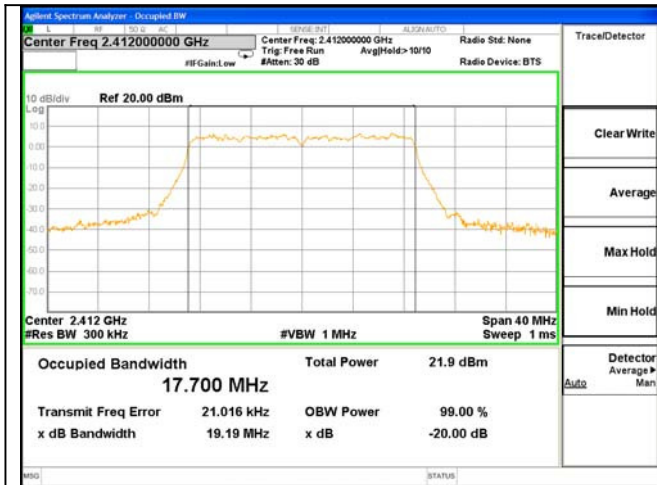

Test Mode: 802.11n20---Low

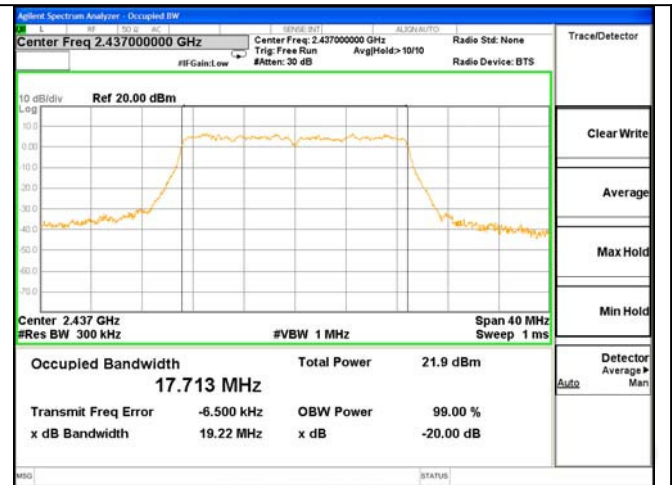

Test Mode: 802.11n20---Mid

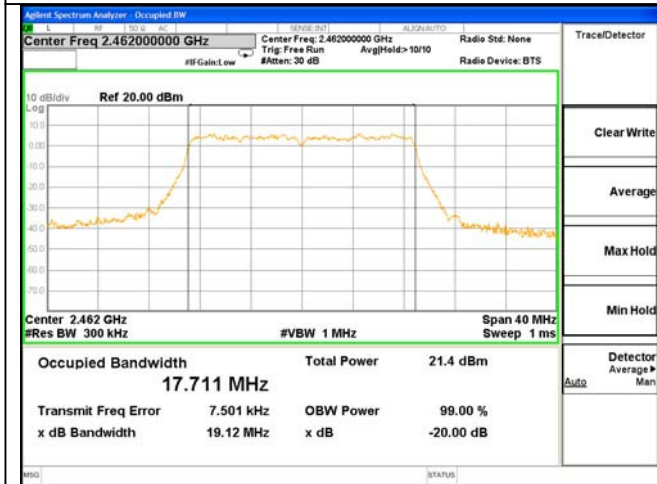

Test Mode: 802.11n20---High

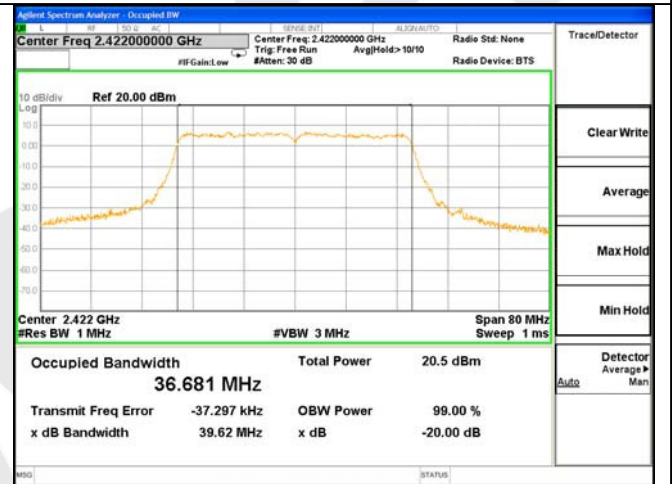

Test Mode: 802.11n40---Low

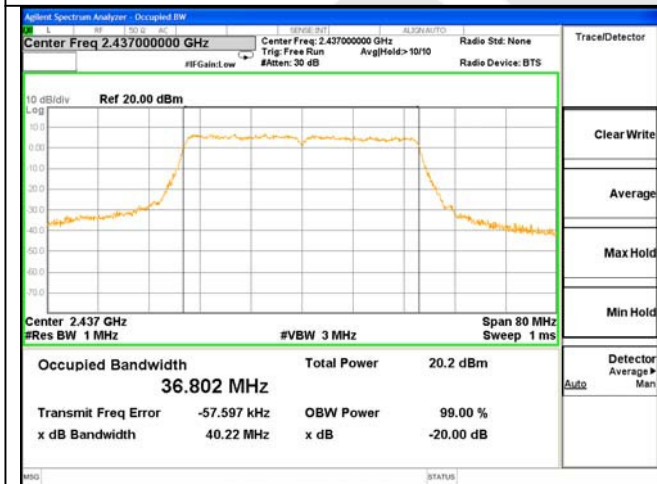

Test Mode: 802.11n40---Mid

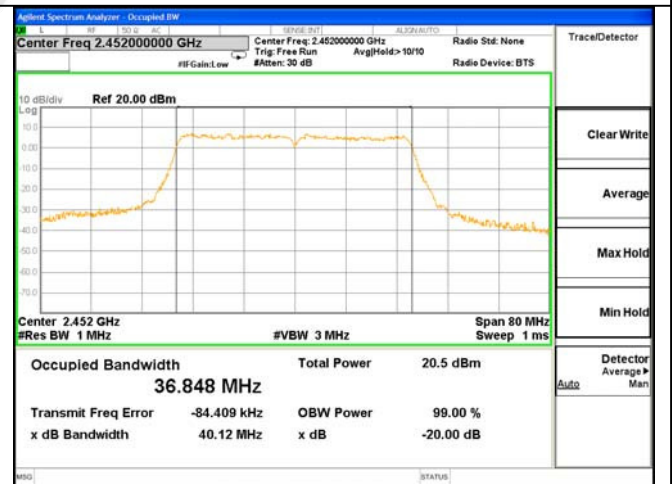

Test Mode: 802.11n40---High

ANT B

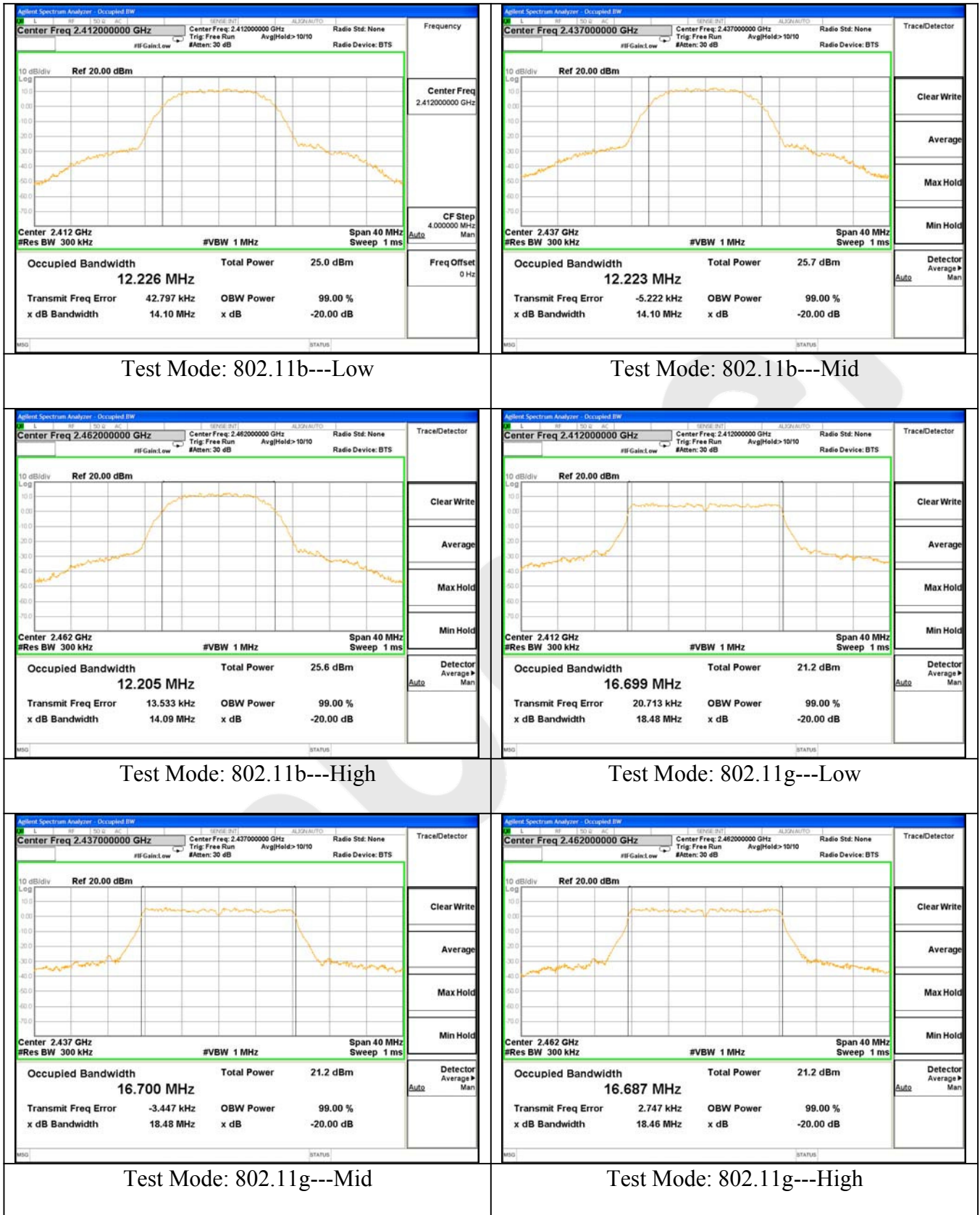

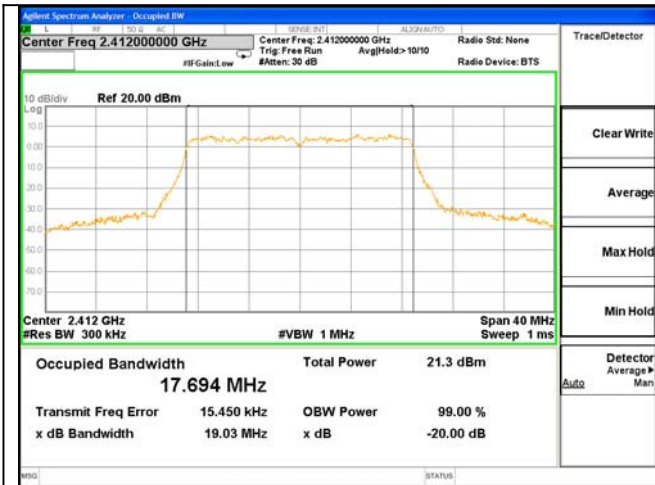

Test Mode: 802.11n20---Low

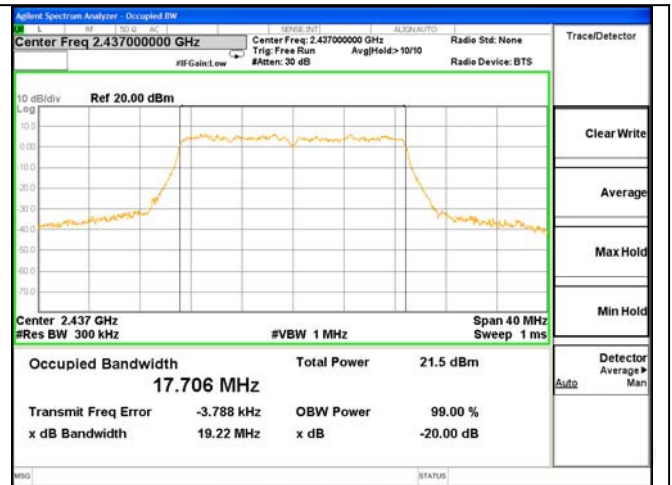

Test Mode: 802.11n20---Mid

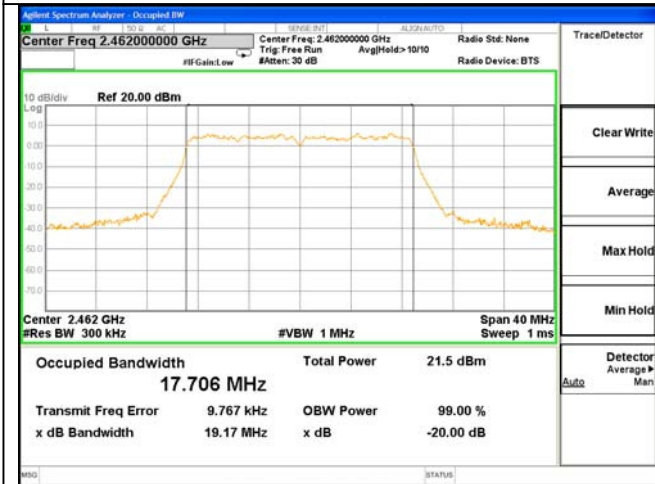

Test Mode: 802.11n20---High

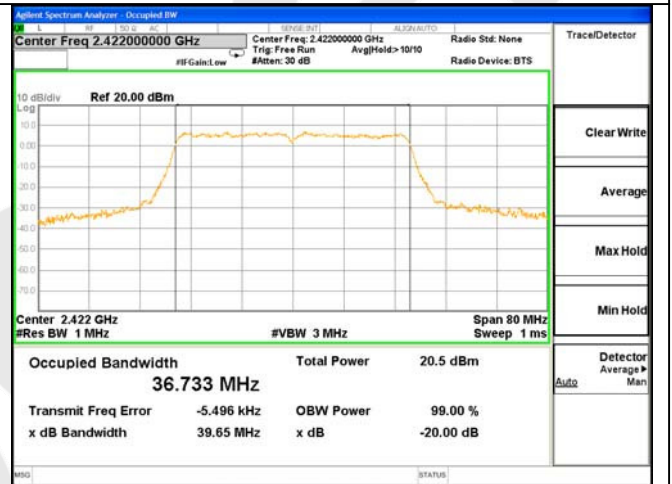

Test Mode: 802.11n40---Low

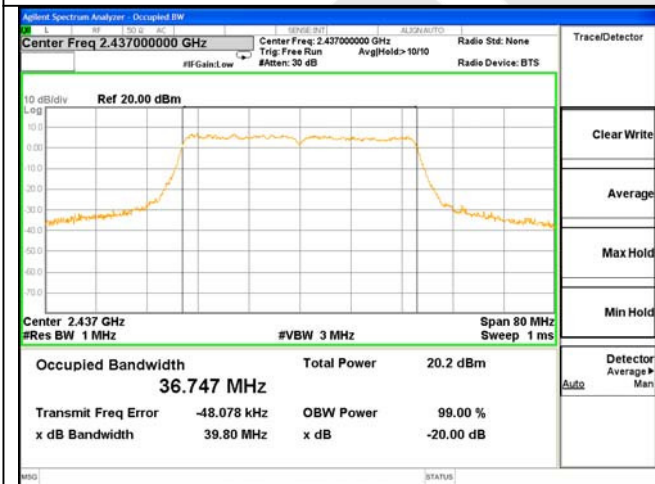

Test Mode: 802.11n40---Mid

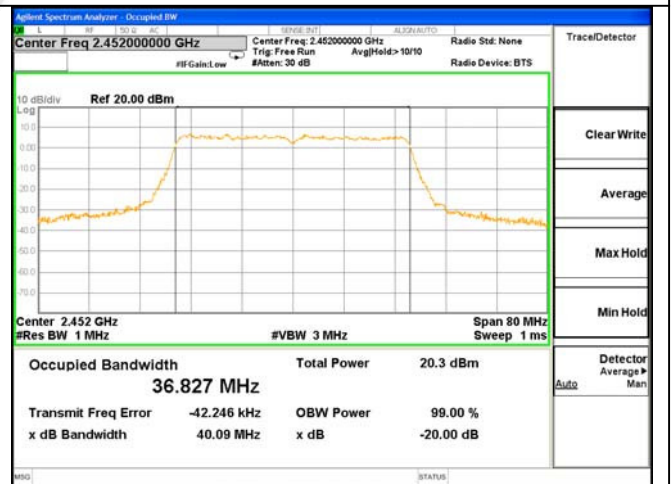

Test Mode: 802.11n40---High

4.3. Maximum Output Power Test

a. Limit

The maximum output power of the intentional radiator shall not exceed the following:

1. For systems using digital modulation in the bands of 902-928 MHz, 2400-2483.5 MHz, and 5725-5850 MHz: 1 watt (30dBm).
2. Except as shown in paragraphs (b)(3) (i), (ii) and (iii) of this section, if transmitting antenna of directional gain greater than 6 dBi are used the peak output power from the intentional radiator shall be reduced below the stated values in paragraphs (b)(1) or (b)(2) of this section, as appropriate, by the amount in dB that the directional gain of the antenna exceeds 6 dBi.

b. Configuration of Measurement

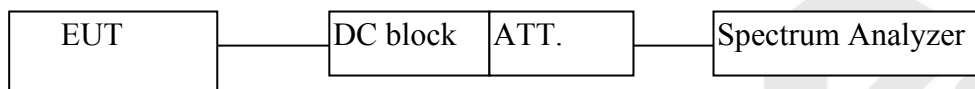

c. Data Rates

IEEE802.11b: Channel 1(2412MHz), Channel 6(2437MHz) and Channel 11(2462MHz) with 1 Mbps data rate (worst case) are chosen for the final testing.

IEEE802.11g: Channel 1(2412MHz), Channel 6(2437MHz) and Channel 11(2462MHz) with 6 Mbps data rate (the worst case) are chosen for the final testing.

IEEE802.11n (HT20: Channel 1(2412MHz), Channel 6(2437MHz) and Channel 11(2462MHz) with 6.5Mbps data rate (the worst case) are chosen for the final testing.

d. Test Procedure

This test was according the kDB 558074 D01 DTS Meas Guidance v03r05 9.1.1:

1. Set span to at least 1.5 times the OBW.
2. Set the RBW =1~5% of the OBW, not to exceed 1MHz.
3. Set $VBW \geq 3 * RBW$.
4. Detector = Average.
5. Sweep time = auto couple.
6. Trace mode = max hold.
7. Allow trace to fully stabilize.

e. Test Equipment

Same as the equipment listed in 4.2.

f. Test Results

Pass.

g. Test Data

Antenna A Gain= 0 dBi

Antenna B Gain= 0 dBi

Array Gain= 3.01 dBi= $G_{ANT}+10*\log(N_{ANT})$ dBi

ANT A

Test mode: IEEE 802.11b

Channel	Frequency (MHz)	Maximum transmit power (dBm)	Limit		Result
			(dBm)	(watts)	
Low	2412	26.05	30	1	Pass
Mid	2437	26.20			Pass
High	2462	25.82			Pass

Test mode: IEEE 802.11g

Channel	Frequency (MHz)	Maximum transmit power (dBm)	Limit		Result
			(dBm)	(watts)	
Low	2412	21.56	30	1	Pass
Mid	2437	21.57			Pass
High	2462	21.05			Pass

Test mode: IEEE 802.11n (HT20)

Channel	Frequency (MHz)	Maximum transmit power (dBm)	Limit		Result
			(dBm)	(watts)	
Low	2412	21.79	30	1	Pass
Mid	2437	21.81			Pass
High	2462	21.39			Pass

Test mode: IEEE 802.11n (HT40)

Channel	Frequency (MHz)	Maximum transmit power (dBm)	Limit		Result
			(dBm)	(watts)	
Low	2422	20.40	30	1	Pass
Mid	2437	20.47			Pass
High	2452	20.58			Pass

ANT B

Test mode: IEEE 802.11b

Channel	Frequency (MHz)	Maximum transmit power (dBm)	Limit		Result
			(dBm)	(watts)	
Low	2412	25.02	30	1	Pass
Mid	2437	25.67			Pass
High	2462	25.58			Pass

Test mode: IEEE 802.11g

Channel	Frequency (MHz)	Maximum transmit power (dBm)	Limit		Result
			(dBm)	(watts)	
Low	2412	21.17	30	1	Pass
Mid	2437	21.16			Pass
High	2462	21.16			Pass

Test mode: IEEE 802.11n (HT20)

Channel	Frequency (MHz)	Maximum transmit power (dBm)	Limit		Result
			(dBm)	(watts)	
Low	2412	21.53	30	1	Pass
Mid	2437	21.63			Pass
High	2462	21.43			Pass

Test mode: IEEE 802.11n (HT40)

Channel	Frequency (MHz)	Maximum transmit power (dBm)	Limit		Result
			(dBm)	(watts)	
Low	2422	20.59	30	1	Pass
Mid	2437	20.24			Pass
High	2452	20.24			Pass

Channel	Channel Frequency (MHz)	ANT A Output Power (dBm)	ANT B Output Power (dBm)	Data Rate (Mbps)	MIMO Output Power (dBm)	Limit (dBm)
802.11n (20M MIMO) mode						
Low	2412	21.79	21.53	MCS0	24.67	30
Middle	2437	21.81	21.63	MCS0	24.73	30
High	2462	21.39	21.43	MCS0	24.42	30
802.11n (40M MIMO) mode						
Low	2422	20.40	20.59	MCS0	23.50	30
Middle	2437	20.47	20.24	MCS0	23.37	30
High	2452	20.58	20.24	MCS0	23.42	30

ANT A

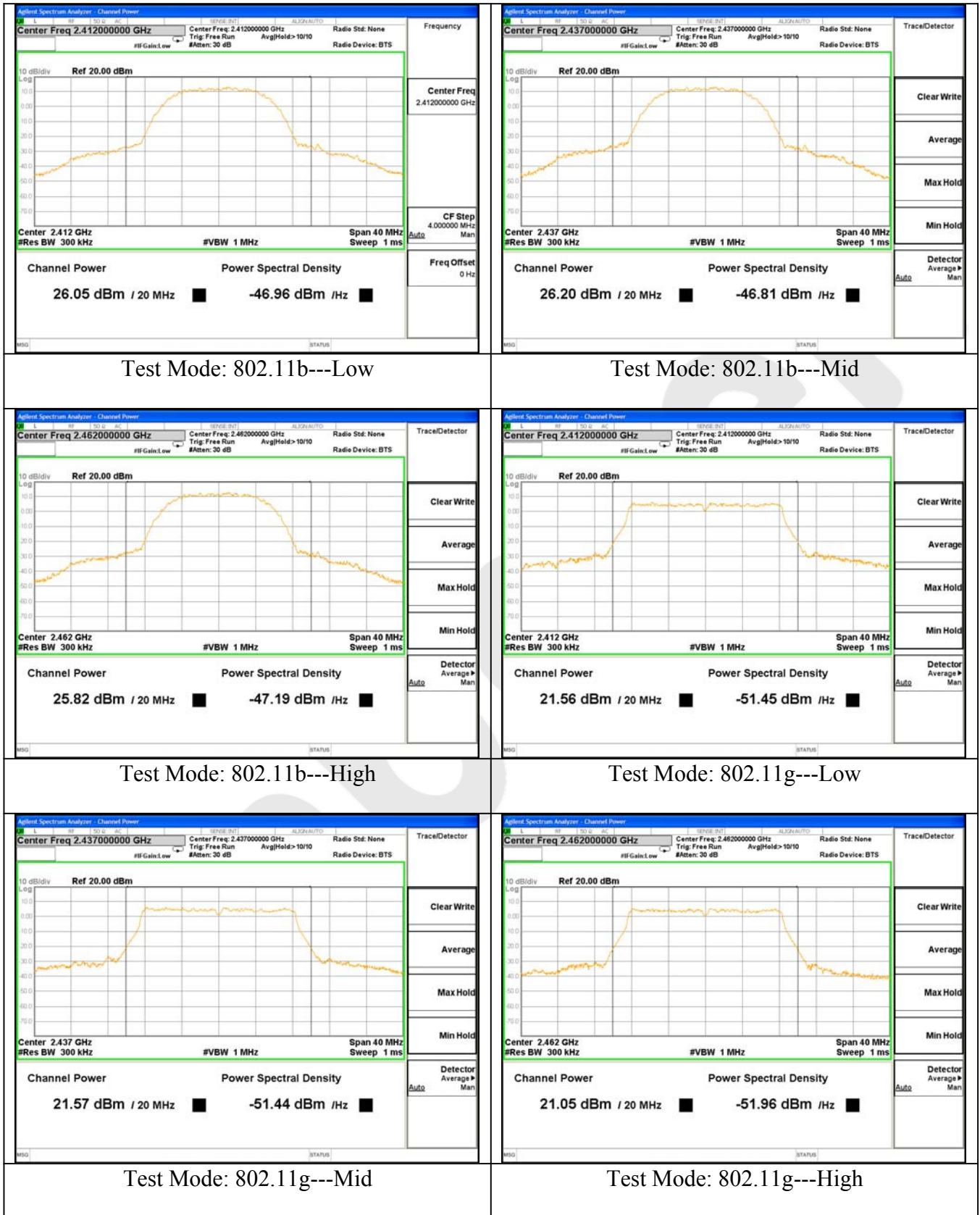

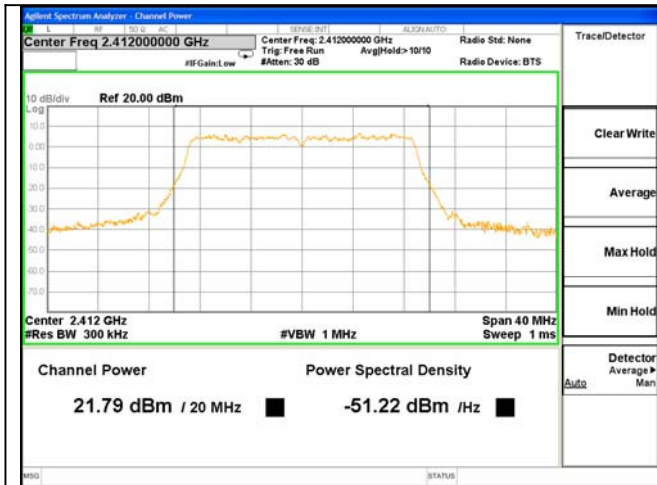

Test Mode: 802.11n20---Low

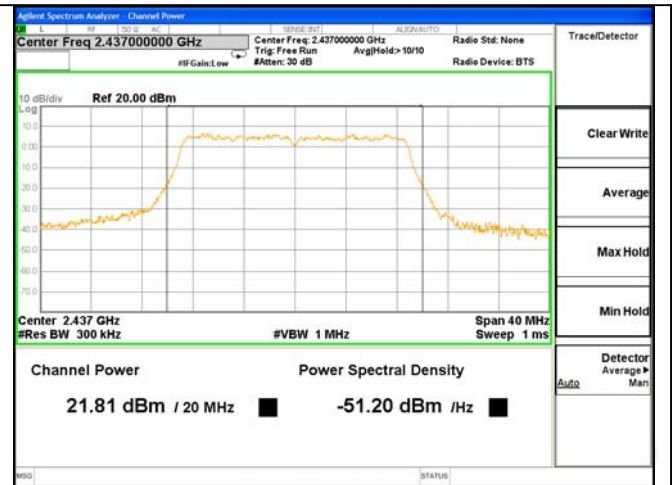

Test Mode: 802.11n20---Mid



Test Mode: 802.11n20---High

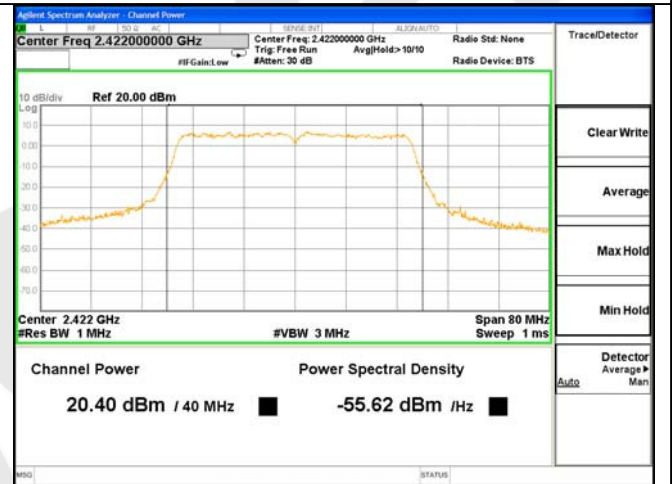

Test Mode: 802.11n40---Low



Test Mode: 802.11n40---Mid

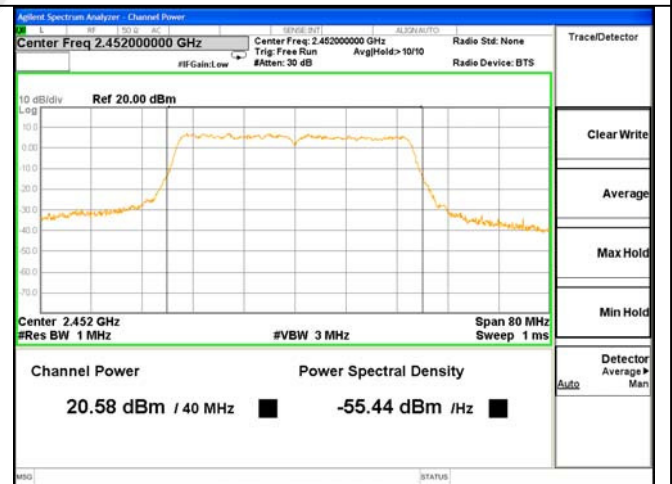

Test Mode: 802.11n40---High

ANT B

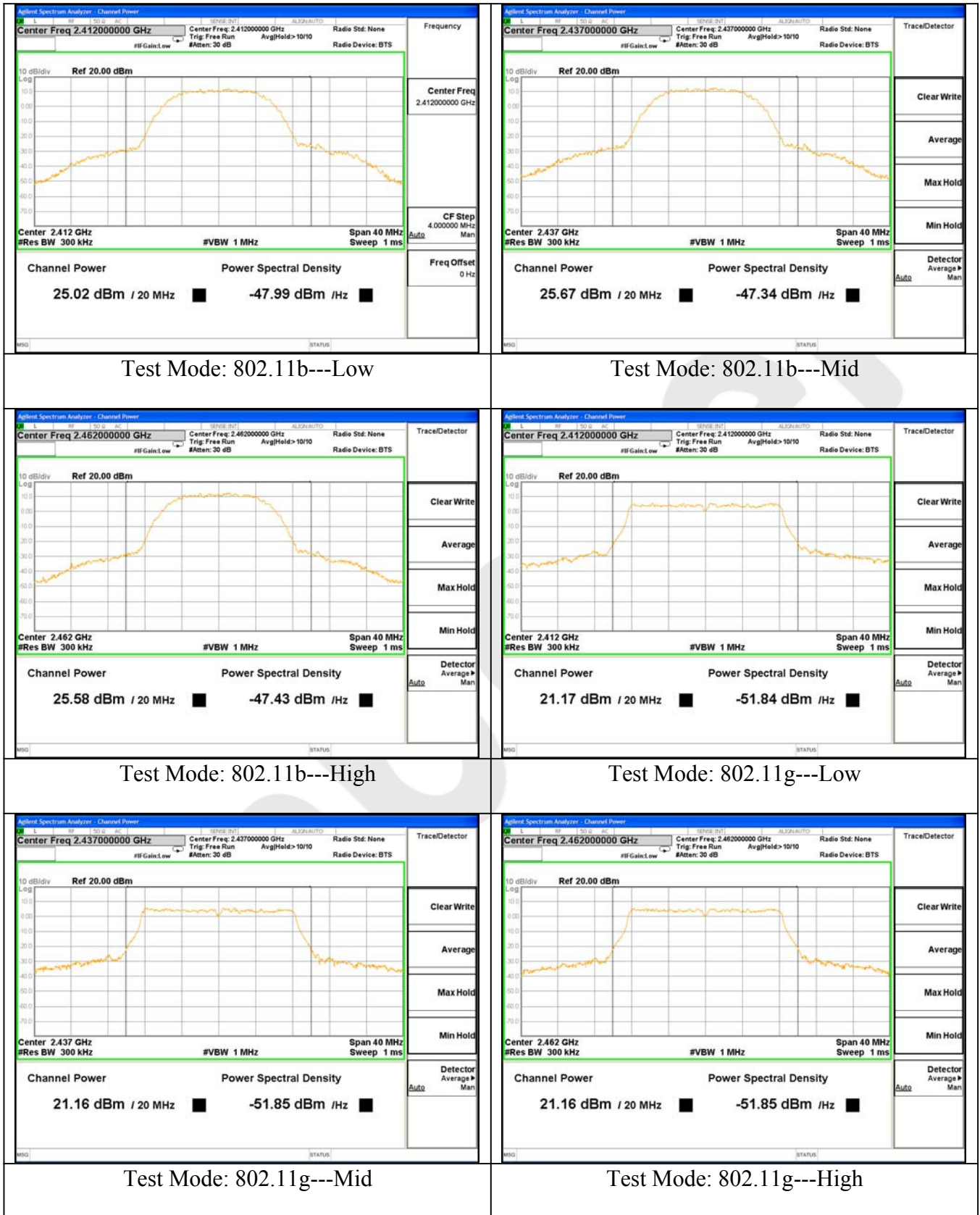



Test Mode: 802.11n20---Low



Test Mode: 802.11n20---Mid



Test Mode: 802.11n20---High



Test Mode: 802.11n40---Low



Test Mode: 802.11n40---Mid



Test Mode: 802.11n40---High

4.4. Band Edges Measurement

a. Limit

According to §15.247(c), in any 100 kHz bandwidth outside the frequency bands in which the spread spectrum intentional radiator is operating, the radio frequency power that is produced by the intentional radiator shall be at least 20dB below that in the 100kHz bandwidth within the band that contains the highest level of the desired power, In addition, radiated emissions which fall in the restricted bands, as defined in §15.205(a), must also comply with the radiated emission limits specified in §15.209(a).

b. Test Procedure

1. Conducted Method:

- 1) Set RBW=100KHz, VBW=300KHz
- 2) Detector=peak
- 3) Sweep time= auto
- 4) Trace mode=max hold.

2. Radiated Method:

- 1) For below 1GHz: The EUT is placed on a turntable, which is 0.8m above the ground plane. The EUT is tested in 9*6*6 Chamber.
For above 1GHz: The EUT is placed on a turntable, which is 1.5m above the ground plane. The EUT is tested in 9*6*6 Chamber.
- 2) The turntable shall be rotated for 360 degrees to determine the position of maximum emission level.
- 3) EUT is set 3m away from the receiving antenna, which is varied from 1m to 4m to find out the highest emission.
- 4) Peak detector: RBW=1MHz, VBW=3MHz, SWT=AUTO
Average detector: RBW=1MHz, VBW=10Hz, SWT=AUTO
The EUT is tested in 9*6*6 Chamber.
- 5) Repeat the procedures until all the PEAK and AVERAGE versus POLARIZATION are measured.

30M to 1G emissions:

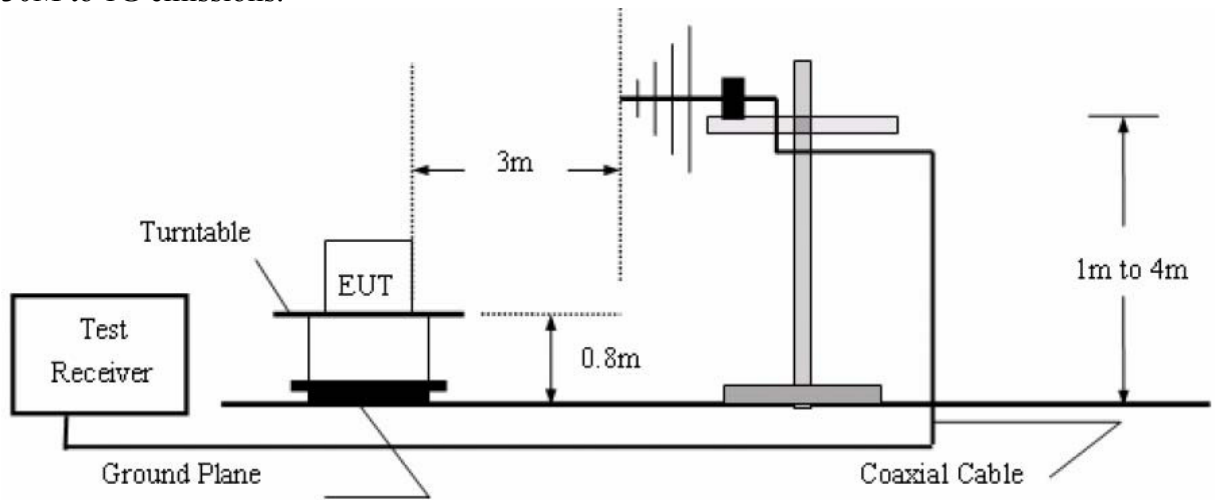

1G to 40G emissions:

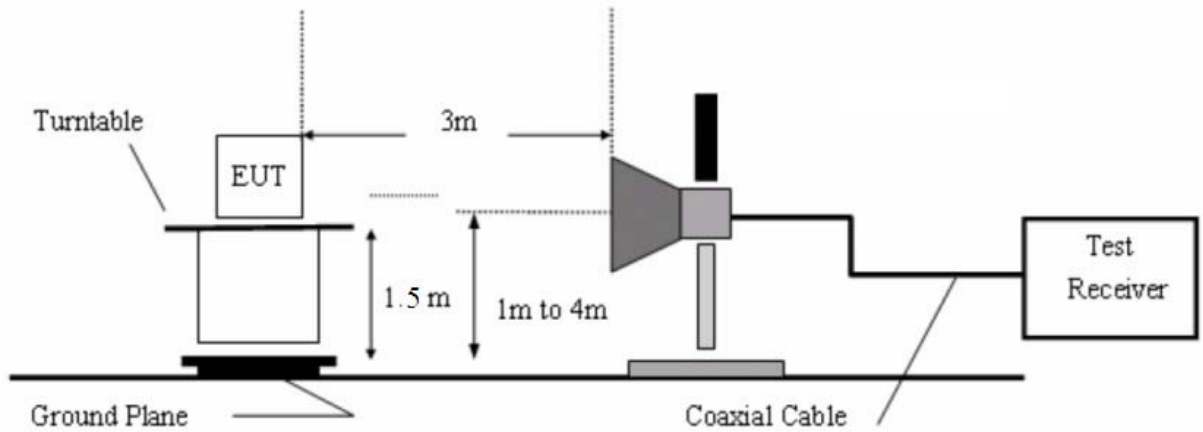

c. Test Equipment

Same as the equipment listed in 4.2.

d. Test Results

Pass.

e. Test Plots

See the following page.

ANT A



Test Mode: 802.11b---Low



Test Mode: 802.11b---High

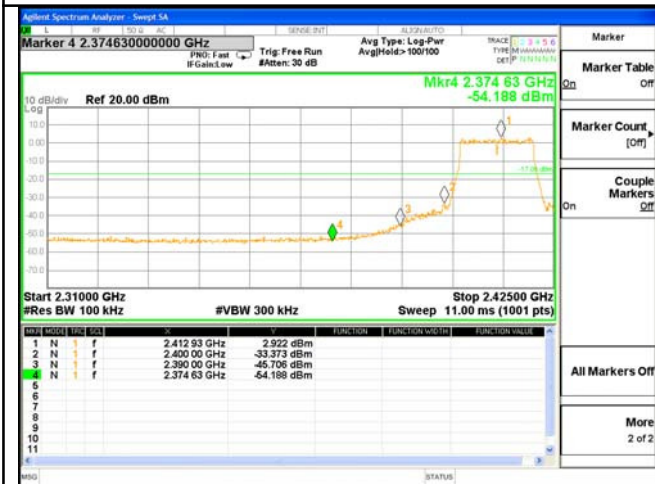

Test Mode: 802.11g---Low



Test Mode: 802.11g---High



Test Mode: 802.11n20---Low

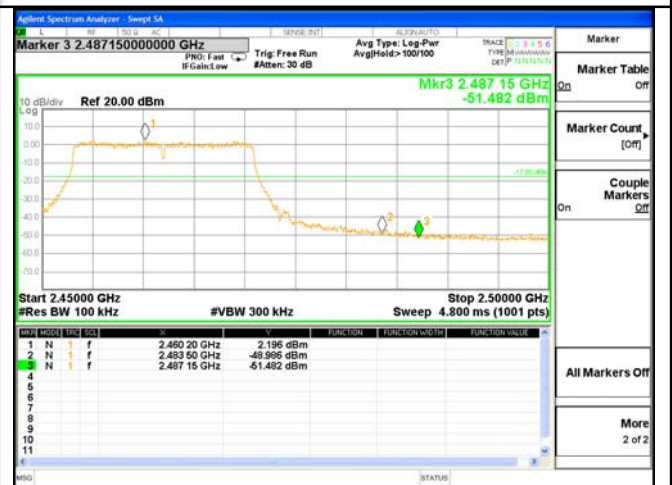

Test Mode: 802.11n20---High



Test Mode: 802.11n40---Low

Test Mode: 802.11n40---High



ANT B

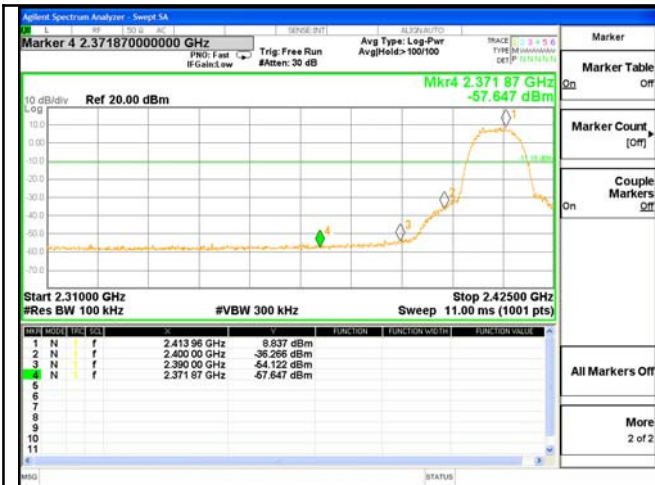

Test Mode: 802.11b---Low

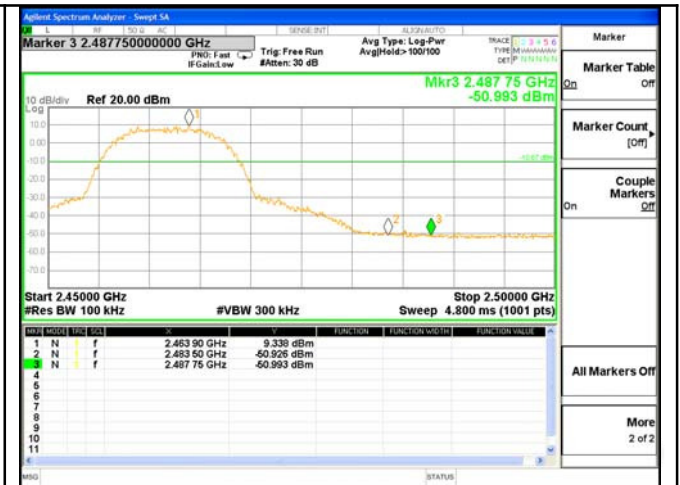

Test Mode: 802.11b---High

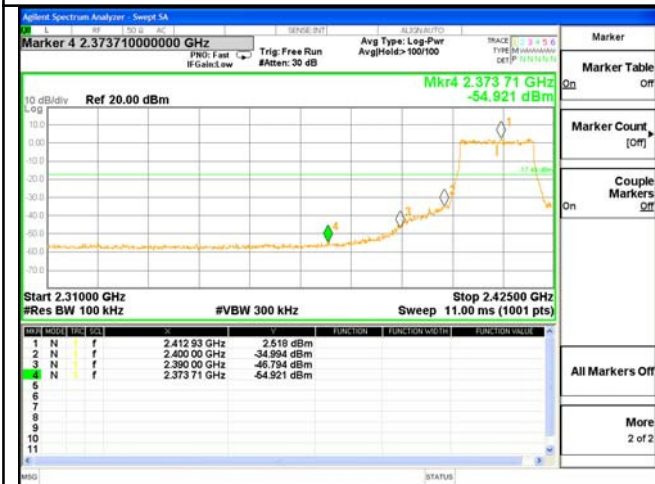

Test Mode: 802.11g---Low



Test Mode: 802.11g---High



Test Mode: 802.11n20---Low

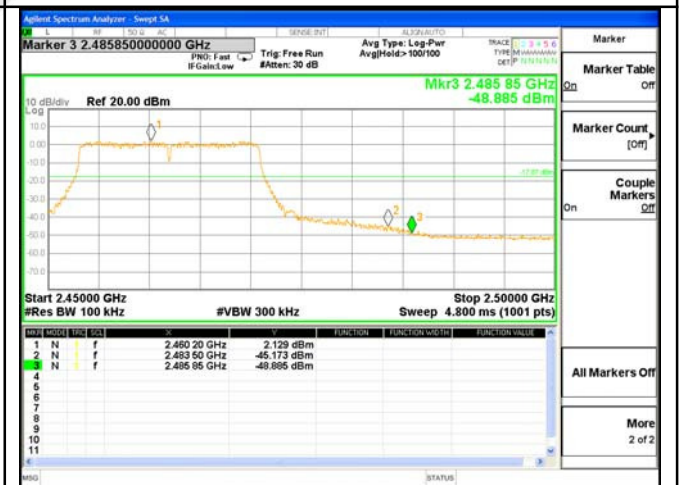

Test Mode: 802.11n20---High

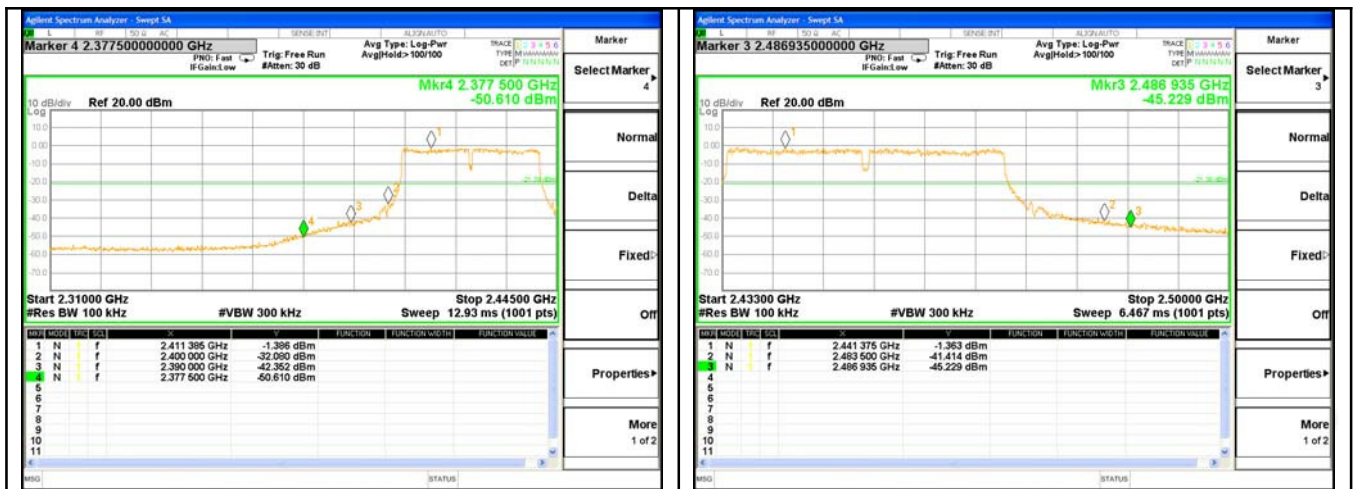

Test Mode: 802.11n40---Low

Test Mode: 802.11n40---High



ANT A

Test Mode: 802.11b

2412MHz

Horizontal-PEAK:

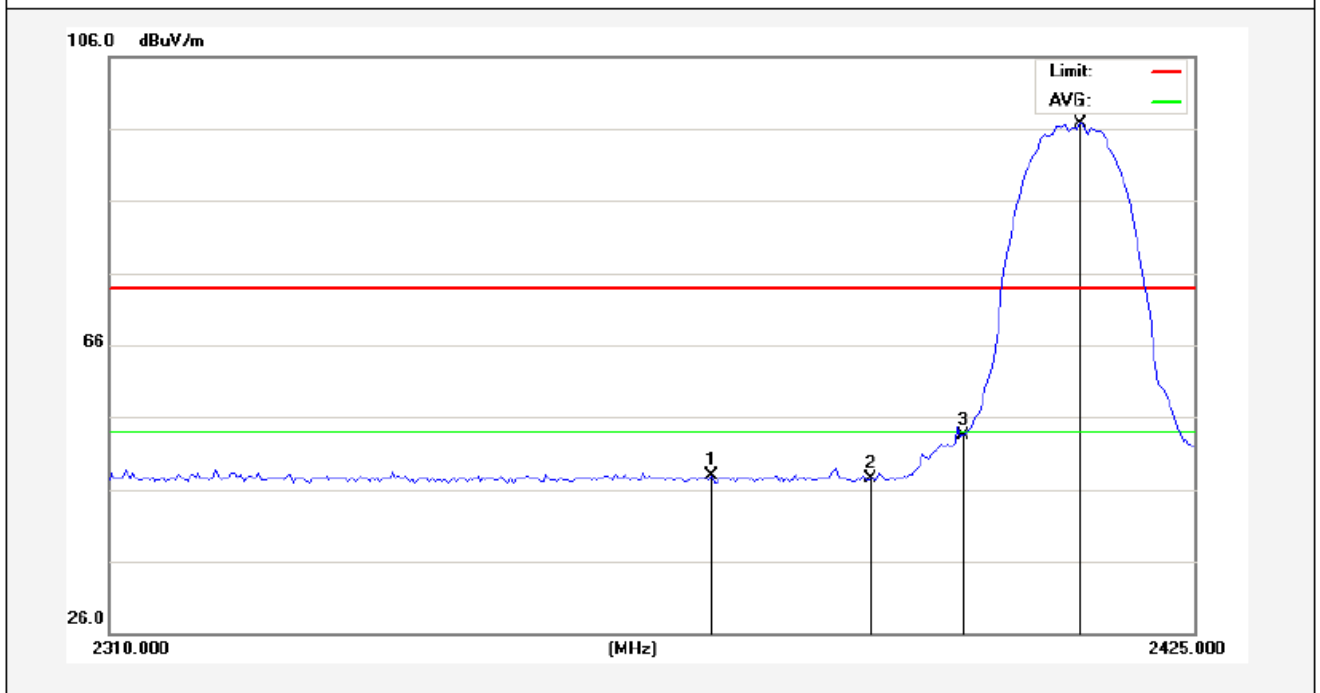

No.	Freq. (MHz)	Reading (dBuV/m)	Factor (dB/m)	Result (dBuV/m)	Limit (dBuV/)	Over Limit (dB)	Detector	Height (cm)	degree (deg)	Remark
1	2373.250	50.37	-2.55	47.82	74.00	-26.18	peak			
2	2390.000	50.04	-2.51	47.53	74.00	-26.47	peak			
3	2400.000	56.00	-2.49	53.51	74.00	-20.49	peak			
4	2412.925	99.19	-2.46	96.73	74.00	22.73	peak			

ANT A

Horizontal-AV:

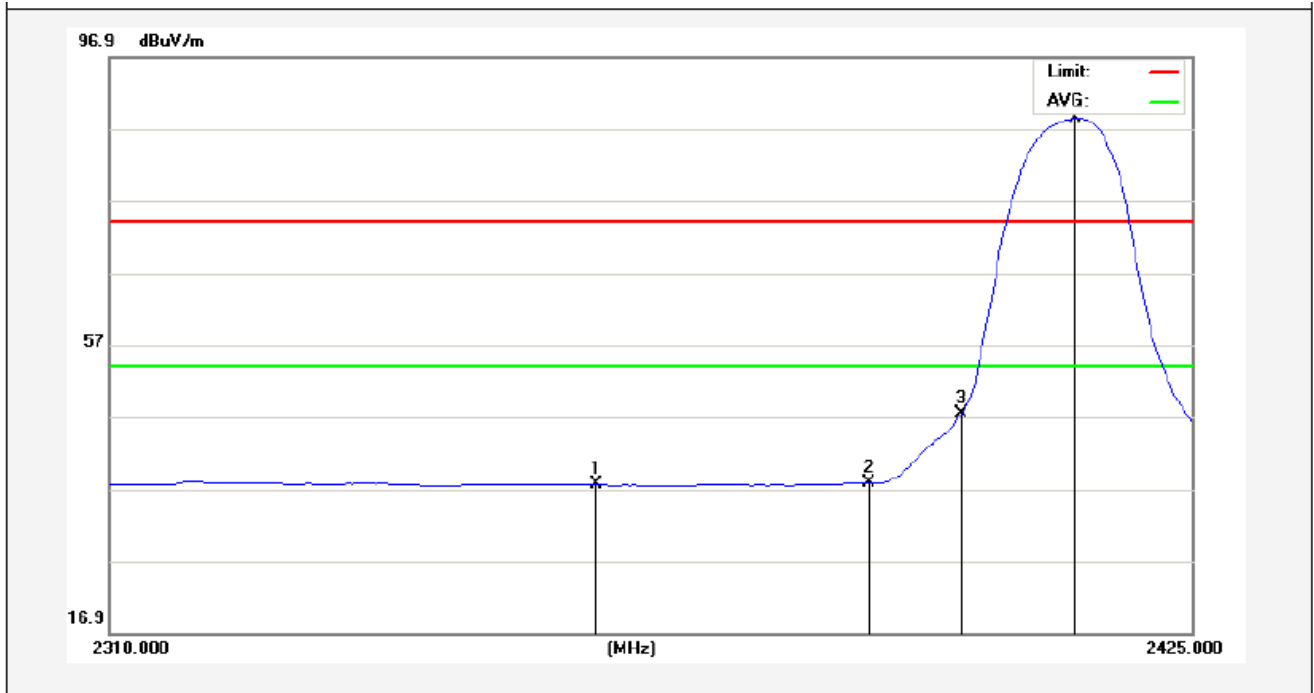

No.	Freq. (MHz)	Reading (dBuV/m)	Factor (dB/m)	Result (dBuV/m)	Limit (dBuV/)	Over Limit (dB)	Detector	Height (cm)	degree (deg)	Remark
1	2361.175	40.15	-2.58	37.57	54.00	-16.43	AVG			
2	2390.000	40.26	-2.51	37.75	54.00	-16.25	AVG			
3	2400.000	49.97	-2.49	47.48	54.00	-6.52	AVG			
4	2412.637	90.82	-2.46	88.36	54.00	34.36	AVG			

Anbotek

Test Mode: 802.11b
2412MHz
Vertical-PEAK:

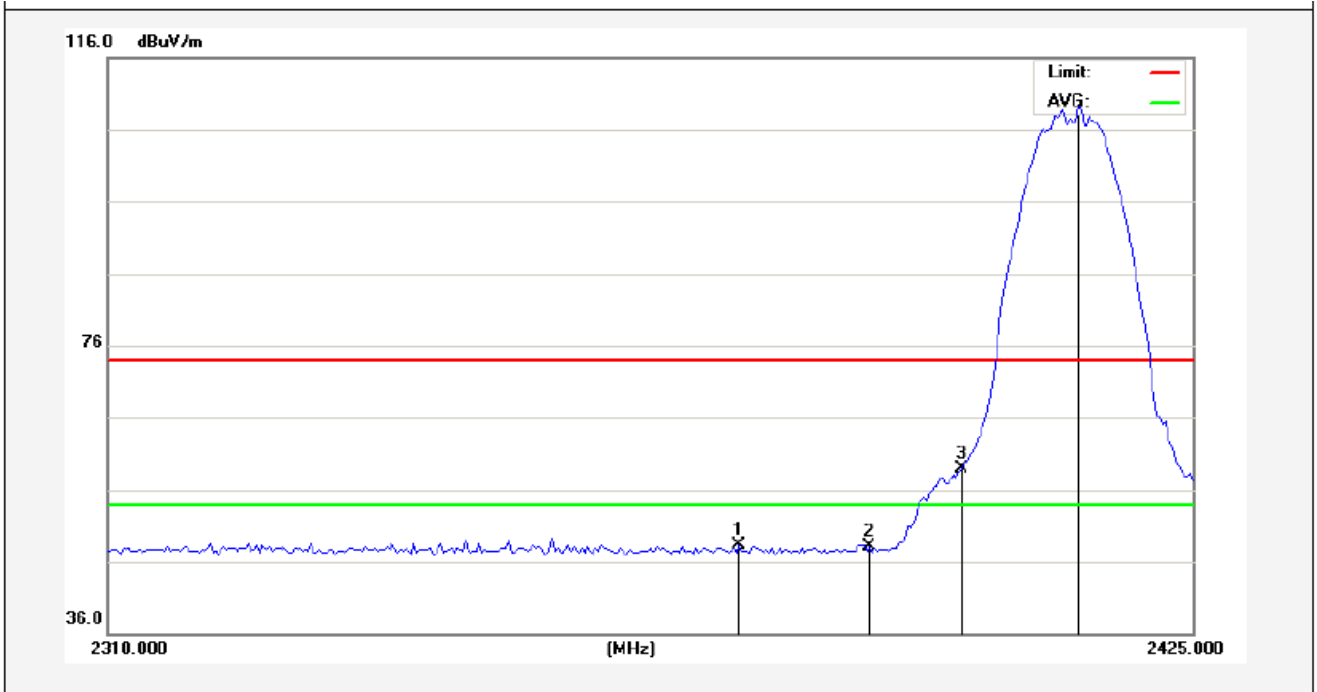

No.	Freq. (MHz)	Reading (dBuV/m)	Factor (dB/m)	Result (dBuV/m)	Limit (dBuV/)	Over Limit (dB)	Detector	Height (cm)	degree (deg)	Remark
1	2376.412	50.77	-2.54	48.23	74.00	-25.77	peak			
2	2390.000	50.52	-2.51	48.01	74.00	-25.99	peak			
3	2400.000	61.46	-2.49	58.97	74.00	-15.03	peak			
4	2412.925	111.79	-2.46	109.33	74.00	35.33	peak			

ANB

Vertical-AV:

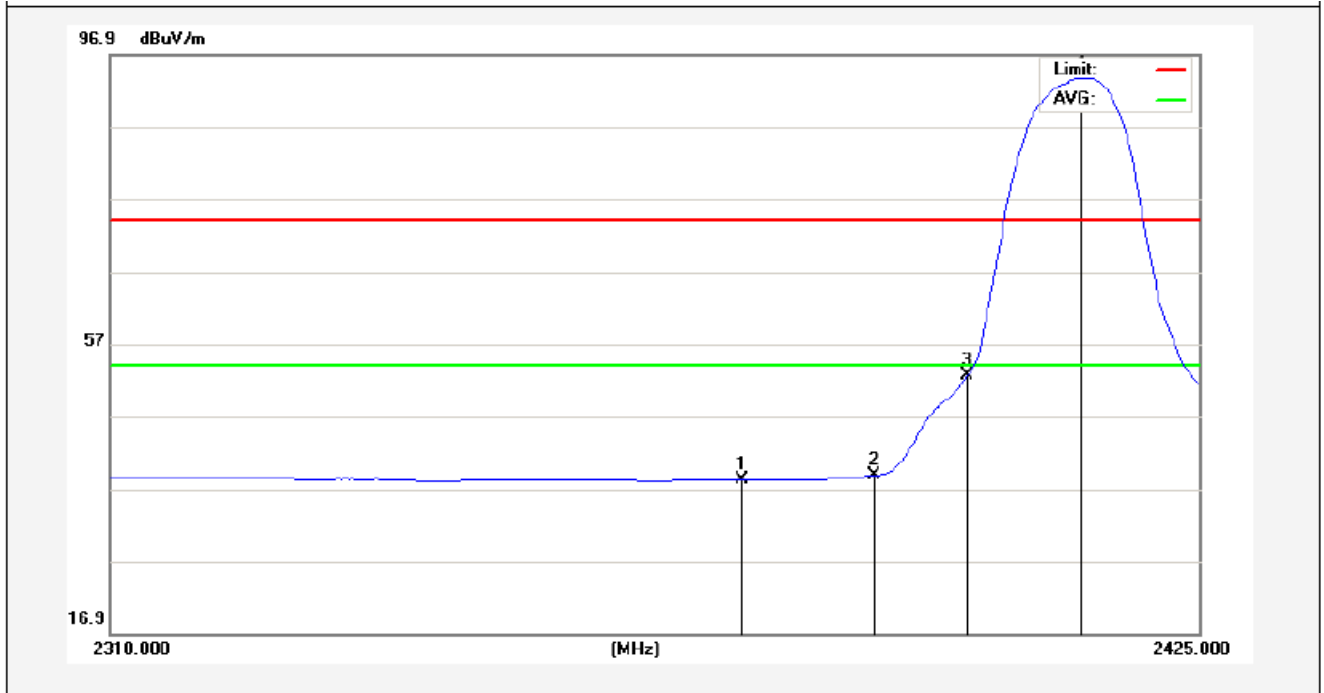

No.	Freq. (MHz)	Reading (dBuV/m)	Factor (dB/m)	Result (dBuV/m)	Limit (dBuV/)	Over Limit (dB)	Detector	Height (cm)	degree (deg)	Remark
1	2376.125	40.80	-2.54	38.26	54.00	-15.74	AVG			
2	2390.000	41.28	-2.51	38.77	54.00	-15.23	AVG			
3	2400.000	55.00	-2.49	52.51	54.00	-1.49	AVG			
4	2412.637	96.14	-2.46	93.68	54.00	39.68	AVG			

Anbotek

Test Mode: 802.11b
2462MHz
Horizontal-PEAK:

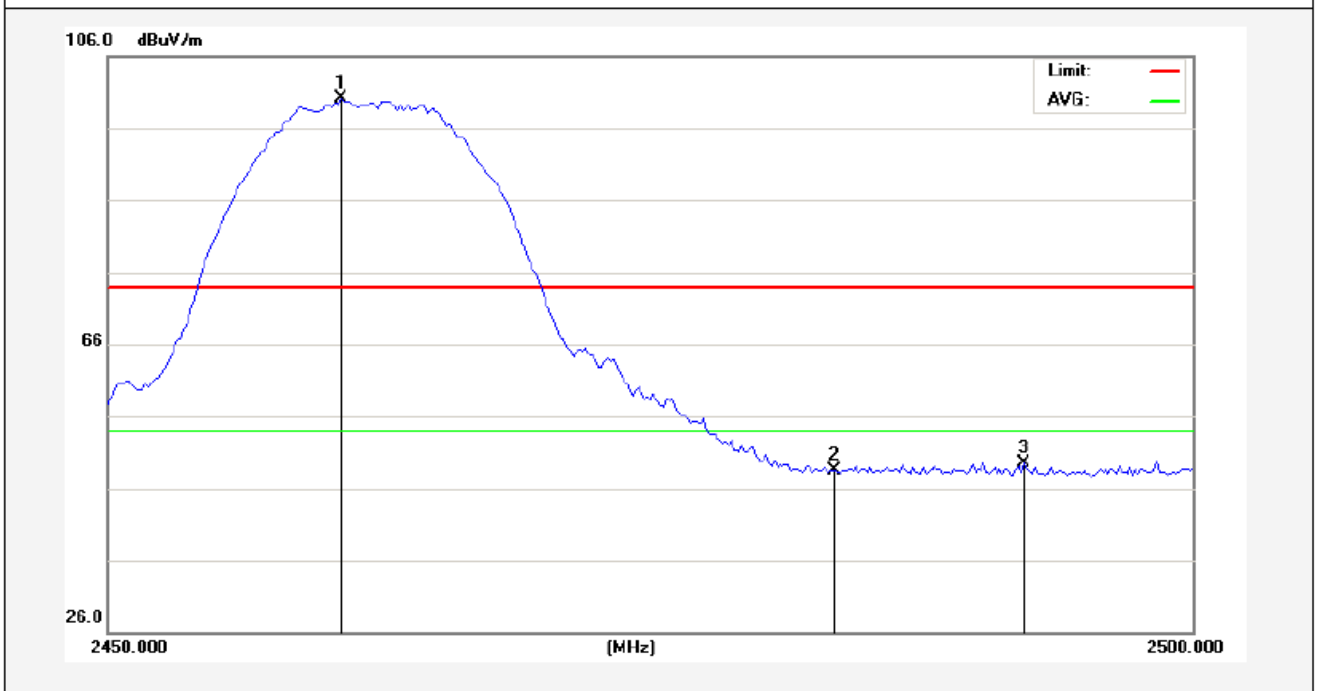

No.	Freq. (MHz)	Reading (dBuV/m)	Factor (dB/m)	Result (dBuV/m)	Limit (dBuV/)	Over Limit (dB)	Detector	Height (cm)	degree (deg)	Remark
1	2460.750	102.48	-2.36	100.12	74.00	26.12	peak			
2	2483.500	50.83	-2.31	48.52	74.00	-25.48	peak			
3	2492.250	51.77	-2.29	49.48	74.00	-24.52	peak			

Anbotek

Horizontal-AV:

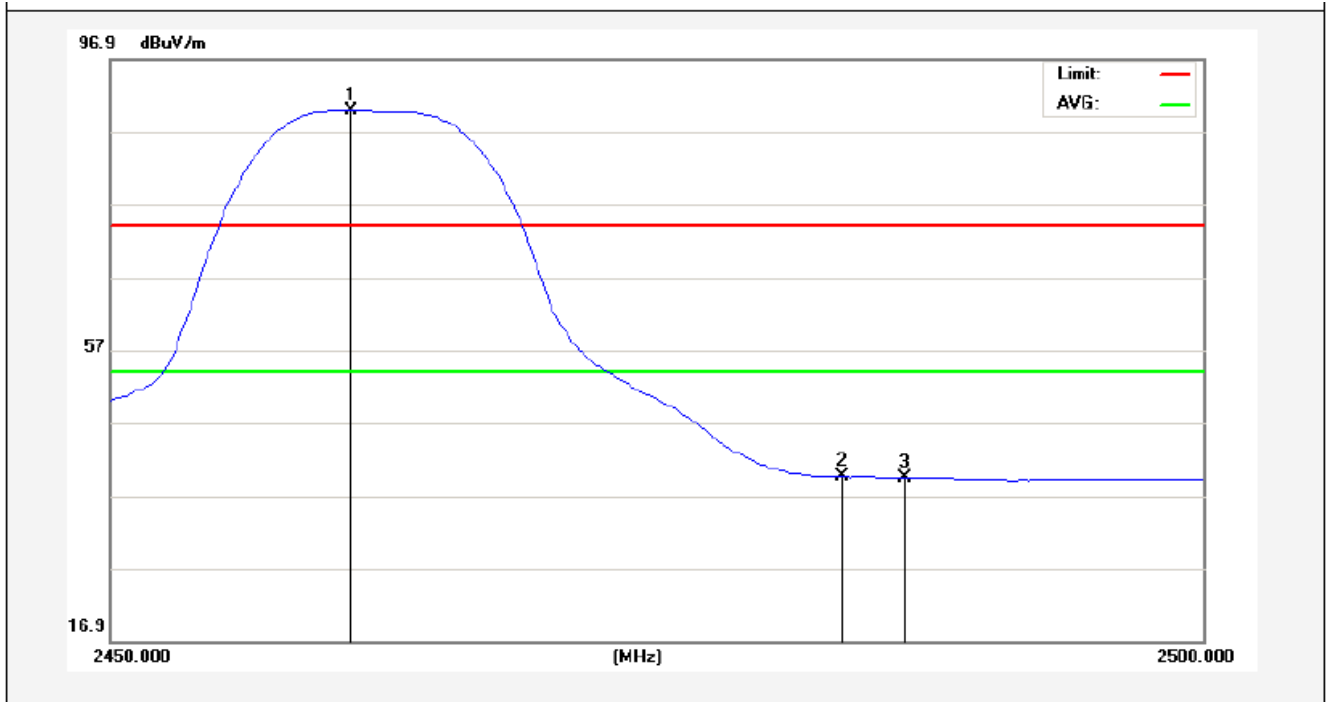

No.	Freq. (MHz)	Reading (dBuV/m)	Factor (dB/m)	Result (dBuV/m)	Limit (dBuV/)	Over Limit (dB)	Detector	Height (cm)	degree (deg)	Remark
1	2461.000	92.18	-2.36	89.82	54.00	35.82	AVG			
2	2483.500	41.84	-2.31	39.53	54.00	-14.47	AVG			
3	2486.375	41.71	-2.30	39.41	54.00	-14.59	AVG			

Anbotek

Test Mode: 802.11b
2462MHz
Vertical-PEAK:

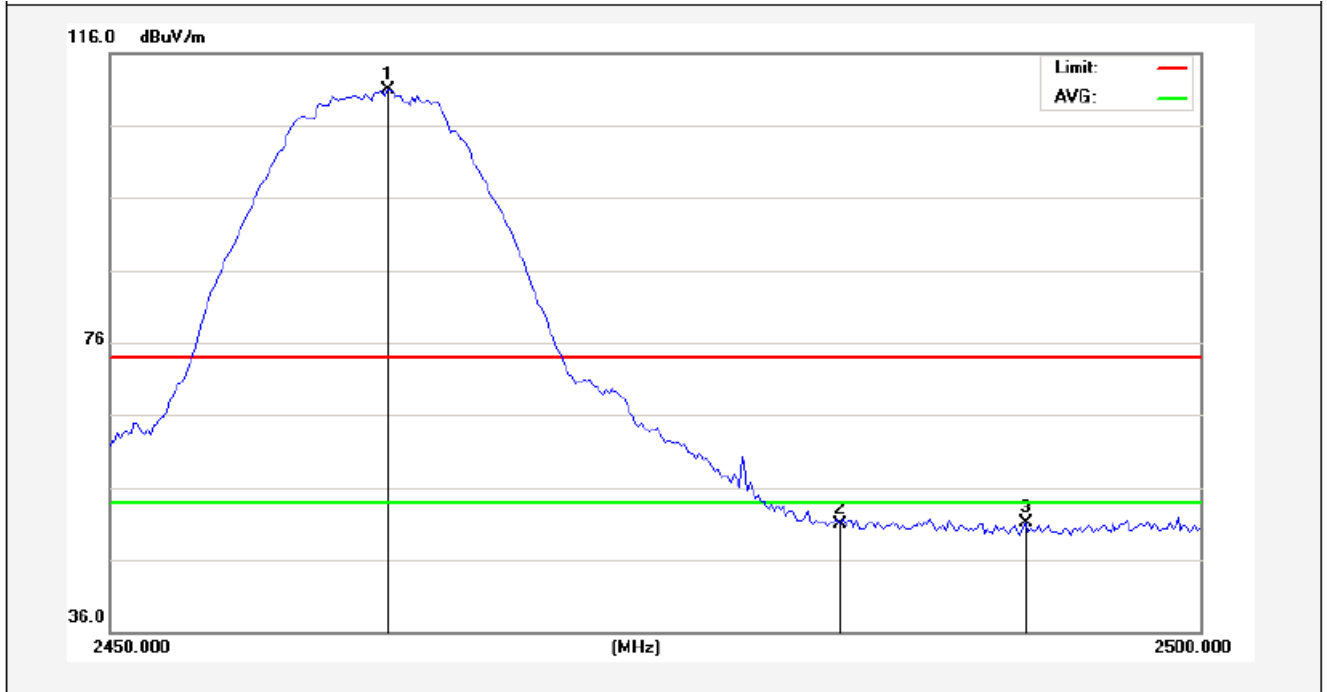

No.	Freq. (MHz)	Reading (dBuV/m)	Factor (dB/m)	Result (dBuV/m)	Limit (dBuV/)	Over Limit (dB)	Detector	Height (cm)	degree (deg)	Remark
1	2462.750	113.24	-2.35	110.89	74.00	36.89	peak			
2	2483.500	53.12	-2.31	50.81	74.00	-23.19	peak			
3	2492.000	53.39	-2.29	51.10	74.00	-22.90	peak			

Vertical-AV:

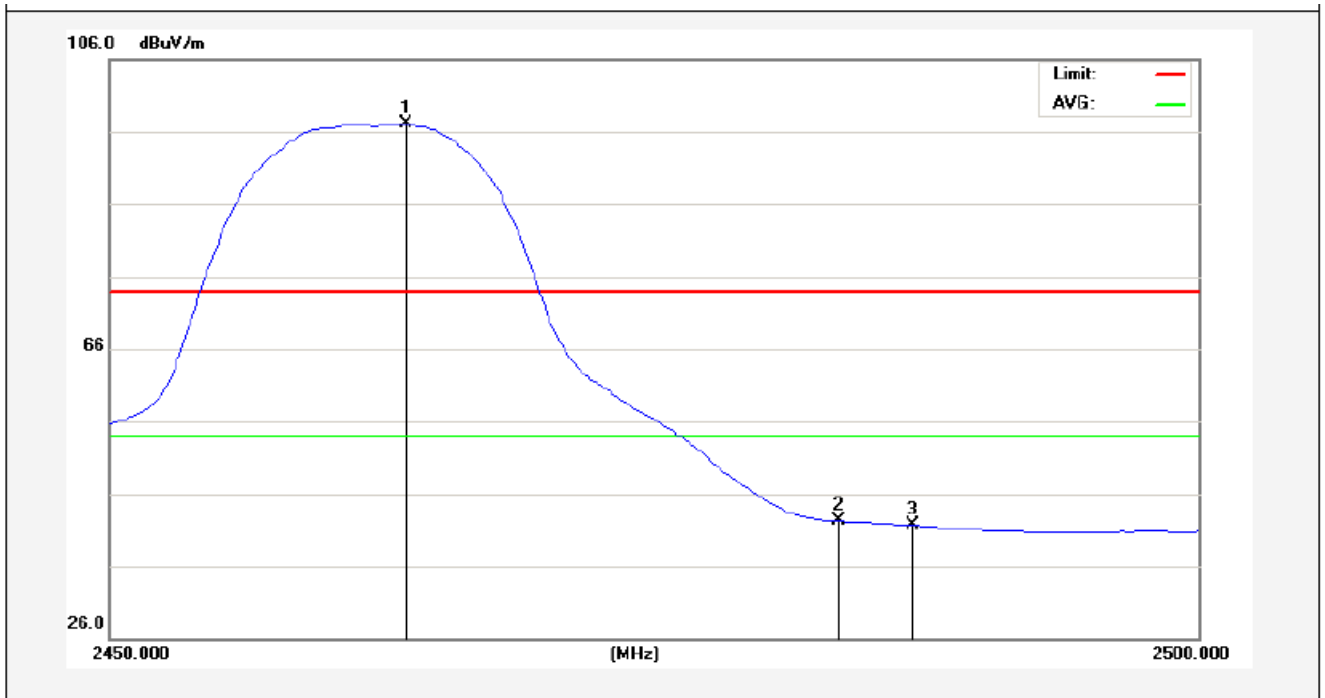

No.	Freq. (MHz)	Reading (dBuV/m)	Factor (dB/m)	Result (dBuV/m)	Limit (dBuV/)	Over Limit (dB)	Detector	Height (cm)	degree (deg)	Remark
1	2463.625	99.50	-2.35	97.15	54.00	43.15	AVG			
2	2483.500	44.52	-2.31	42.21	54.00	-11.79	AVG			
3	2486.875	43.93	-2.30	41.63	54.00	-12.37	AVG			

Anbotek

Test Mode: 802.11g
2412MHz
Horizontal-PEAK:

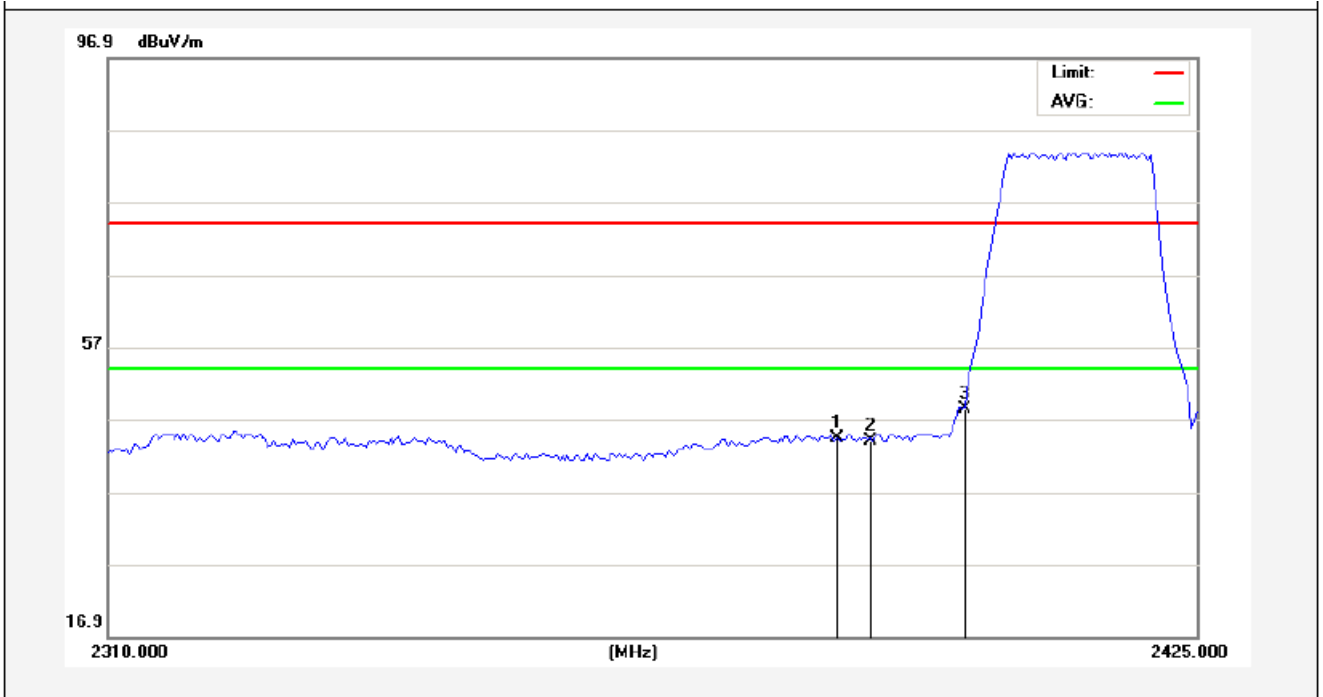

No.	Freq. (MHz)	Reading (dBuV/m)	Factor (dB/m)	Result (dBuV/m)	Limit (dBuV/)	Over Limit (dB)	Detector	Height (cm)	degree (deg)	Remark
1	2386.475	46.87	-2.52	44.35	74.00	-29.65	peak			
2	2390.000	46.55	-2.51	44.04	74.00	-29.96	peak			
3	2400.000	50.99	-2.49	48.50	74.00	-25.50	peak			

Anbotek

Horizontal-AV:

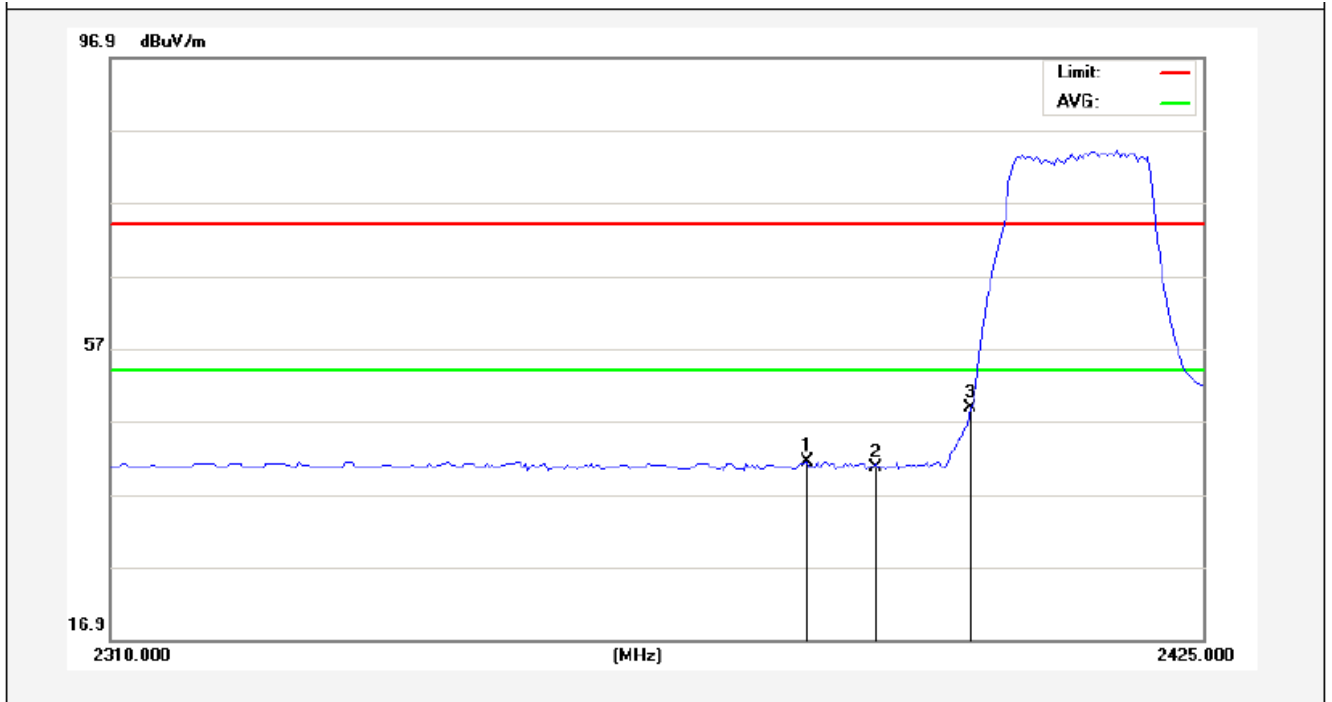

No.	Freq. (MHz)	Reading (dBuV/m)	Factor (dB/m)	Result (dBuV/m)	Limit (dBuV/)	Over Limit (dB)	Detector	Height (cm)	degree (deg)	Remark
1	2382.738	43.93	-2.53	41.40	54.00	-12.60	AVG			
2	2390.000	43.18	-2.51	40.67	54.00	-13.33	AVG			
3	2400.000	51.29	-2.49	48.80	54.00	-5.20	AVG			

Anbotek

Test Mode: 802.11g
2412MHz
Vertical-PEAK:

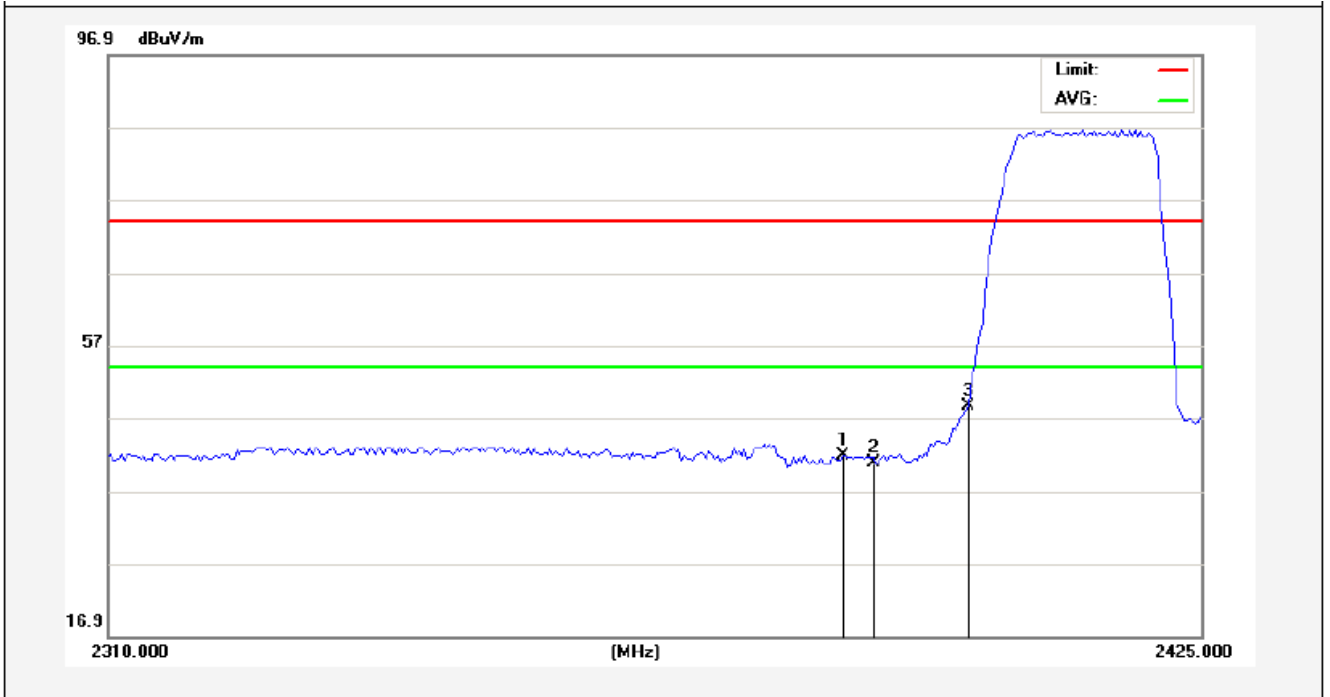

No.	Freq. (MHz)	Reading (dBuV/m)	Factor (dB/m)	Result (dBuV/m)	Limit (dBuV/)	Over Limit (dB)	Detector	Height (cm)	degree (deg)	Remark
1	2386.762	44.31	-2.52	41.79	74.00	-32.21	peak			
2	2390.000	43.36	-2.51	40.85	74.00	-33.15	peak			
3	2400.000	51.16	-2.49	48.67	74.00	-25.33	peak			

Anbotek

Vertical-AV:

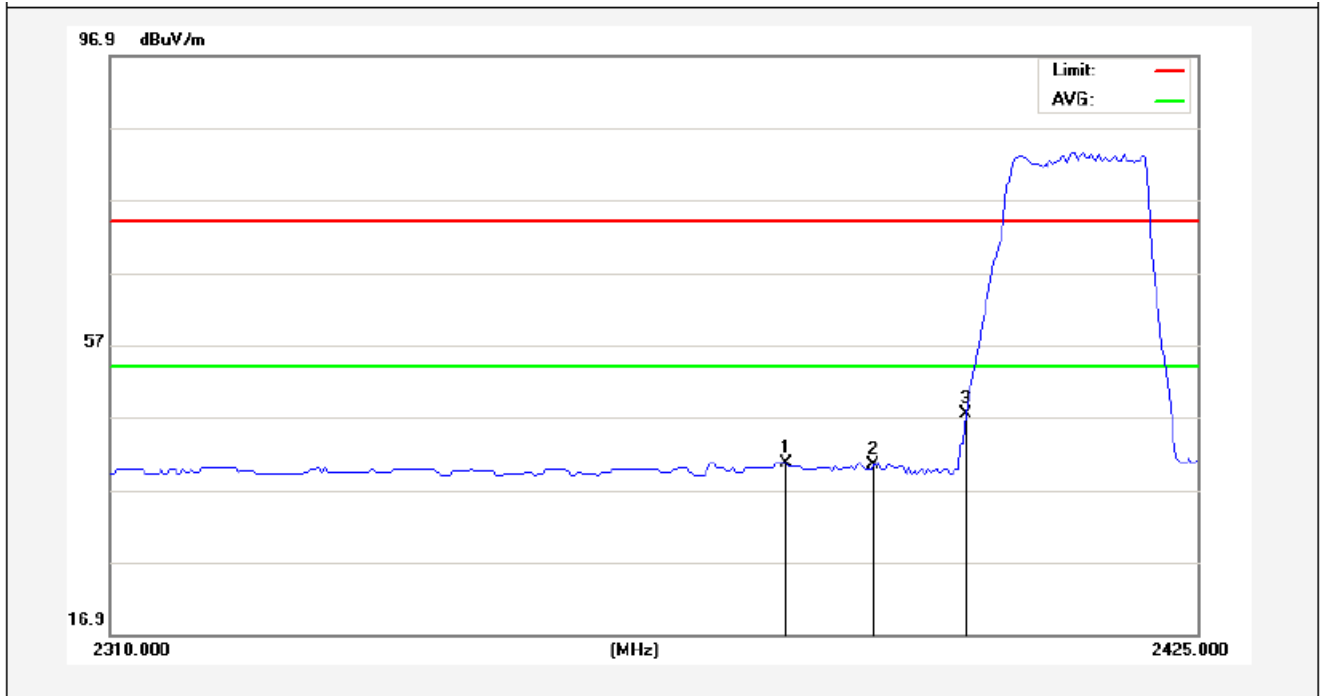

No.	Freq. (MHz)	Reading (dBuV/m)	Factor (dB/m)	Result (dBuV/m)	Limit (dBuV/)	Over Limit (dB)	Detector	Height (cm)	degree (deg)	Remark
1	2381.012	43.11	-2.53	40.58	54.00	-13.42	AVG			
2	2390.000	42.93	-2.51	40.42	54.00	-13.58	AVG			
3	2400.000	49.91	-2.49	47.42	54.00	-6.58	AVG			

Anbotek

Test Mode: 802.11g
2462MHz
Horizontal-PEAK:

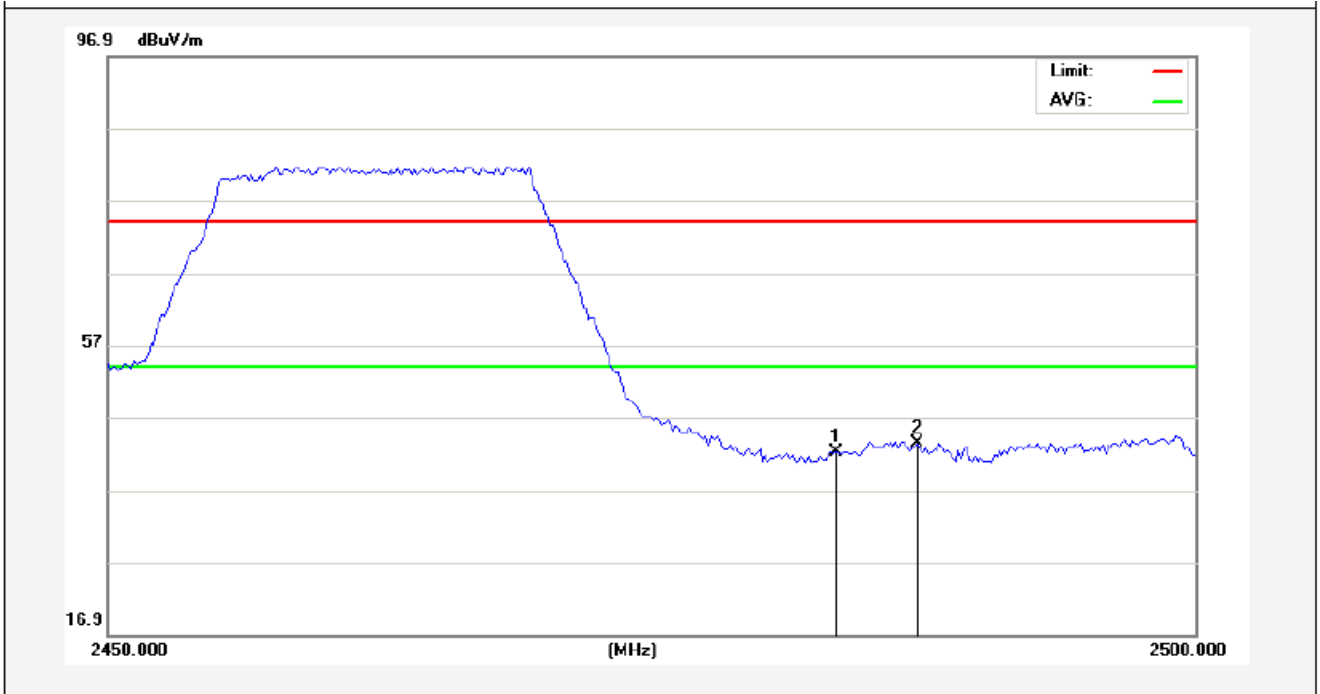

No.	Freq. (MHz)	Reading (dBuV/m)	Factor (dB/m)	Result (dBuV/m)	Limit (dBuV/)	Over Limit (dB)	Detector	Height (cm)	degree (deg)	Remark
1	2483.500	44.44	-2.31	42.13	74.00	-31.87	peak			
2	2487.250	45.61	-2.30	43.31	74.00	-30.69	peak			

Anbotek

Horizontal-AV:

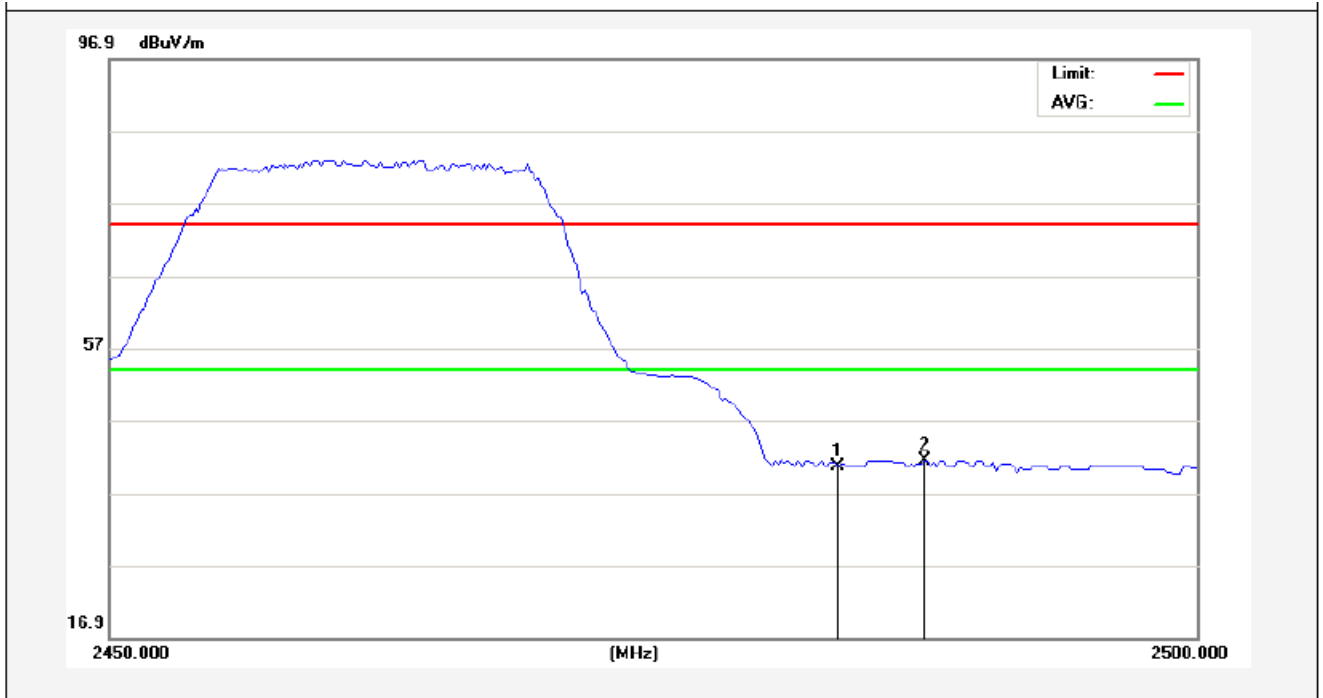

No.	Freq. (MHz)	Reading (dBuV/m)	Factor (dB/m)	Result (dBuV/m)	Limit (dBuV/)	Over Limit (dB)	Detector	Height (cm)	degree (deg)	Remark
1	2483.500	42.88	-2.31	40.57	54.00	-13.43	AVG			
2	2487.500	43.68	-2.30	41.38	54.00	-12.62	AVG			

Anbotek

Test Mode: 802.11g
2462MHz
Vertical-PEAK:

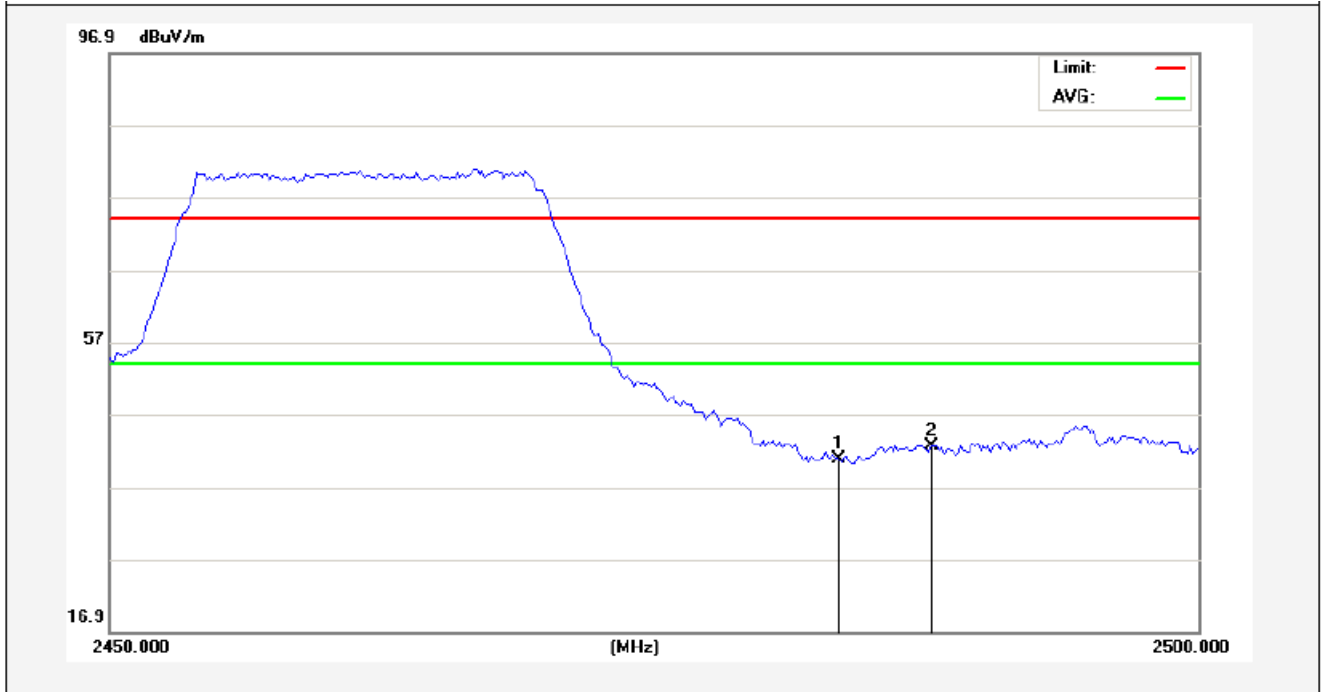

No.	Freq. (MHz)	Reading (dBuV/m)	Factor (dB/m)	Result (dBuV/m)	Limit (dBuV/)	Over Limit (dB)	Detector	Height (cm)	degree (deg)	Remark
1	2483.500	43.07	-2.31	40.76	74.00	-33.24	peak			
2	2487.750	44.90	-2.30	42.60	74.00	-31.40	peak			

Anbotek

Vertical-AV:

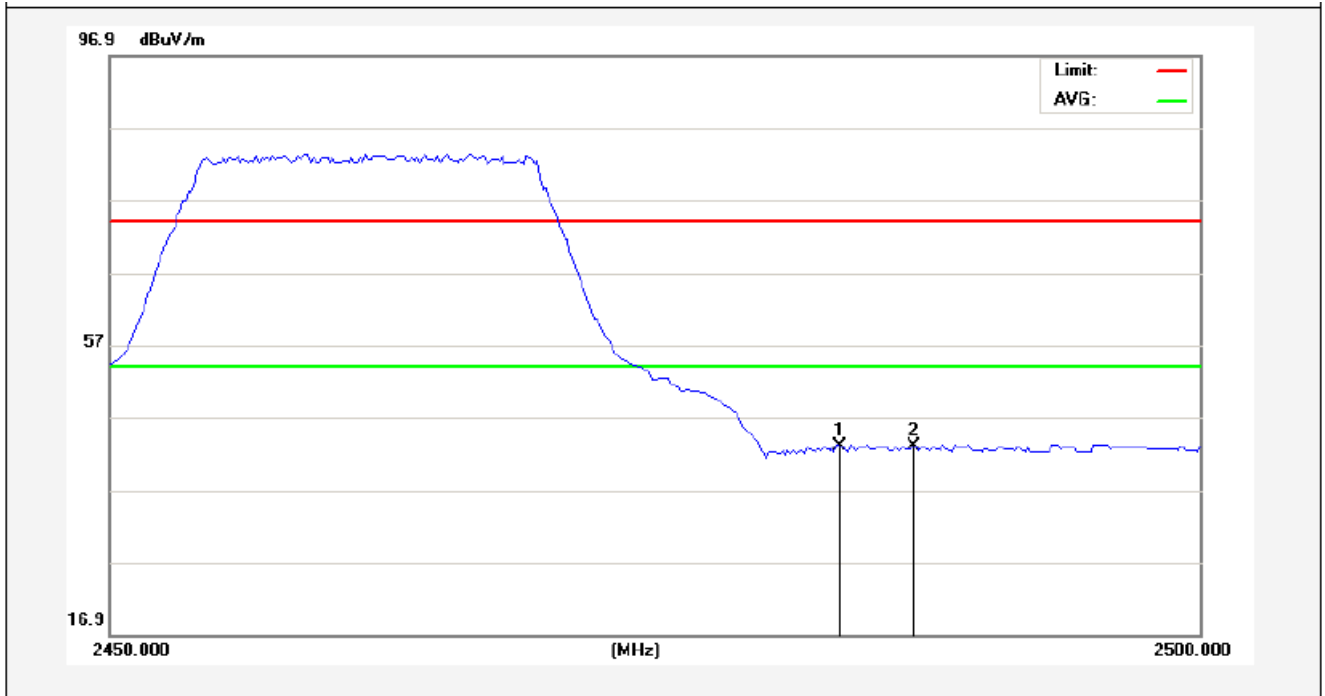

No.	Freq. (MHz)	Reading (dBuV/m)	Factor (dB/m)	Result (dBuV/m)	Limit (dBuV/)	Over Limit (dB)	Detector	Height (cm)	degree (deg)	Remark
1	2483.500	45.38	-2.31	43.07	54.00	-10.93	AVG			
2	2486.875	45.32	-2.30	43.02	54.00	-10.98	AVG			

Anbotek

Test Mode: 802.11n (HT20)

2412MHz

Horizontal-PEAK:

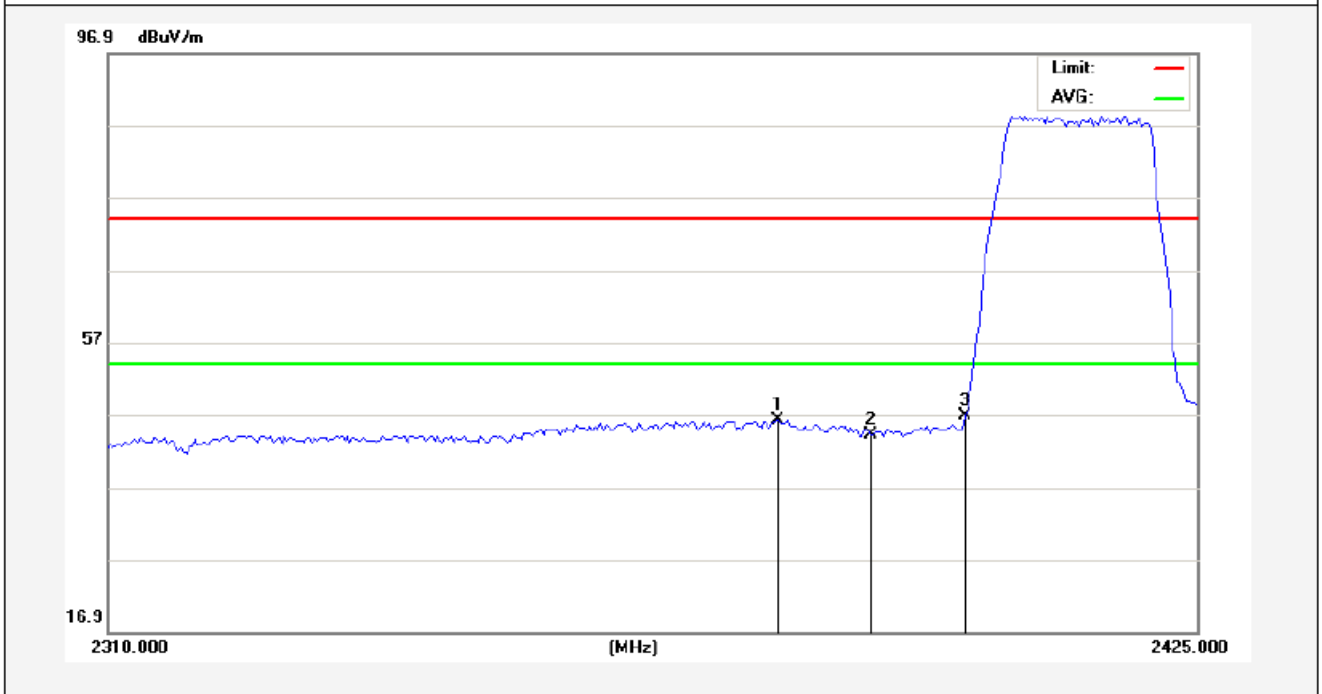

No.	Freq. (MHz)	Reading (dBuV/m)	Factor (dB/m)	Result (dBuV/m)	Limit (dBuV/)	Over Limit (dB)	Detector	Height (cm)	degree (deg)	Remark
1	2380.150	48.73	-2.54	46.19	74.00	-27.81	peak			
2	2390.000	46.63	-2.51	44.12	74.00	-29.88	peak			
3	2400.000	49.23	-2.49	46.74	74.00	-27.26	peak			

Anbotek

Horizontal-AV:

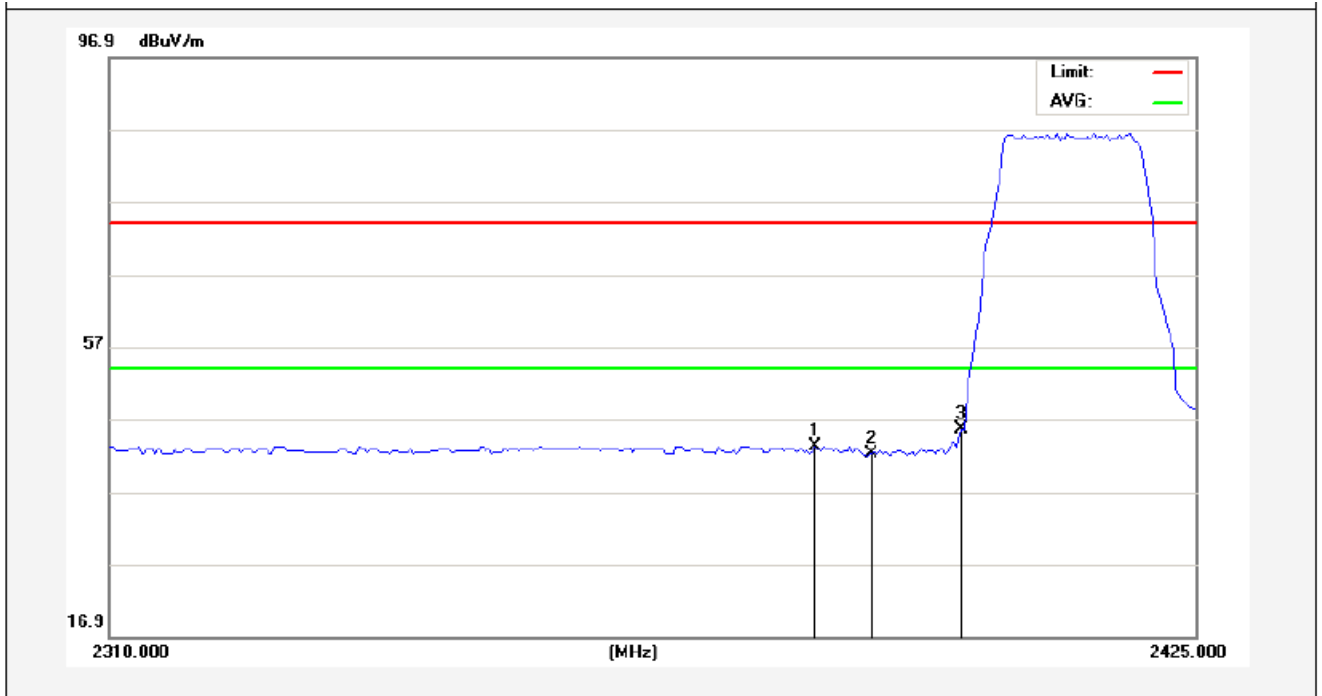

No.	Freq. (MHz)	Reading (dBuV/m)	Factor (dB/m)	Result (dBuV/m)	Limit (dBuV/)	Over Limit (dB)	Detector	Height (cm)	degree (deg)	Remark
1	2384.175	45.68	-2.53	43.15	54.00	-10.85	AVG			
2	2390.000	44.80	-2.51	42.29	54.00	-11.71	AVG			
3	2400.000	48.00	-2.49	45.51	54.00	-8.49	AVG			

Anbotek

Test Mode: 802.11n (HT20)

2412MHz

Vertical-PEAK:

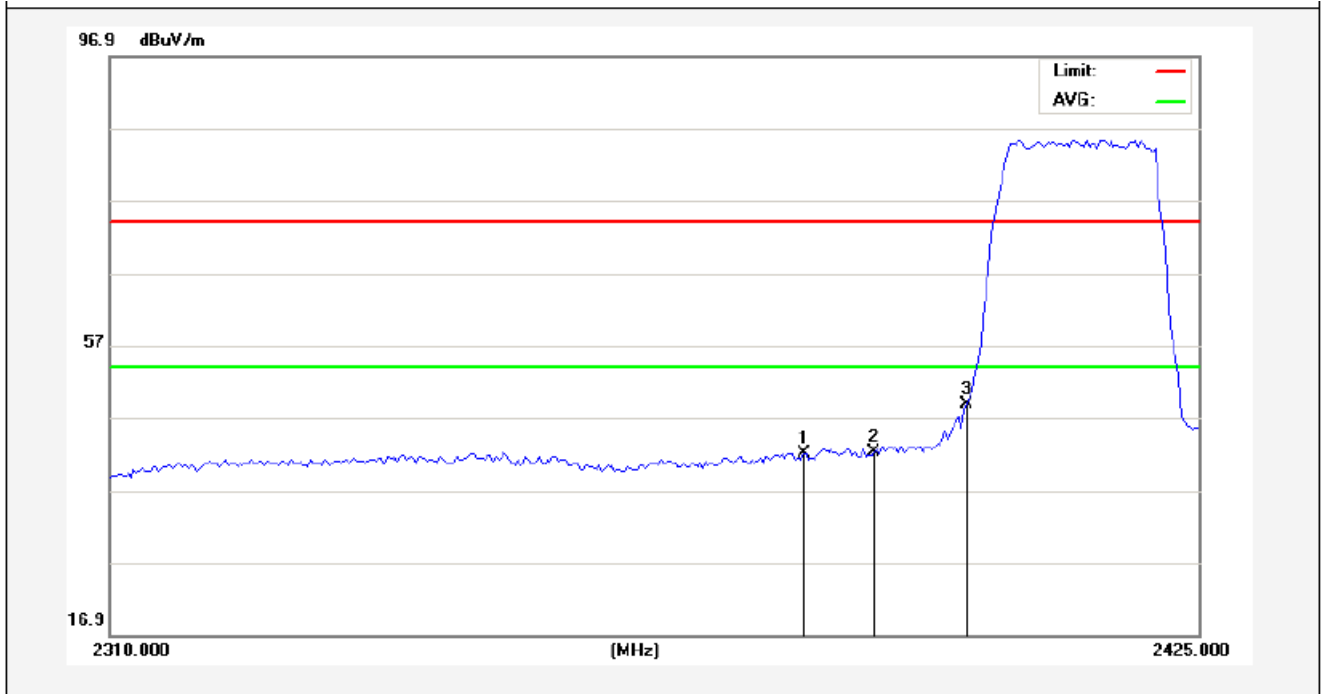

No.	Freq. (MHz)	Reading (dBuV/m)	Factor (dB/m)	Result (dBuV/m)	Limit (dBuV/)	Over Limit (dB)	Detector	Height (cm)	degree (deg)	Remark
1	2382.738	44.62	-2.53	42.09	74.00	-31.91	peak			
2	2390.000	44.63	-2.51	42.12	74.00	-31.88	peak			
3	2400.000	51.25	-2.49	48.76	74.00	-25.24	peak			

Anbotek

Vertical-AV:

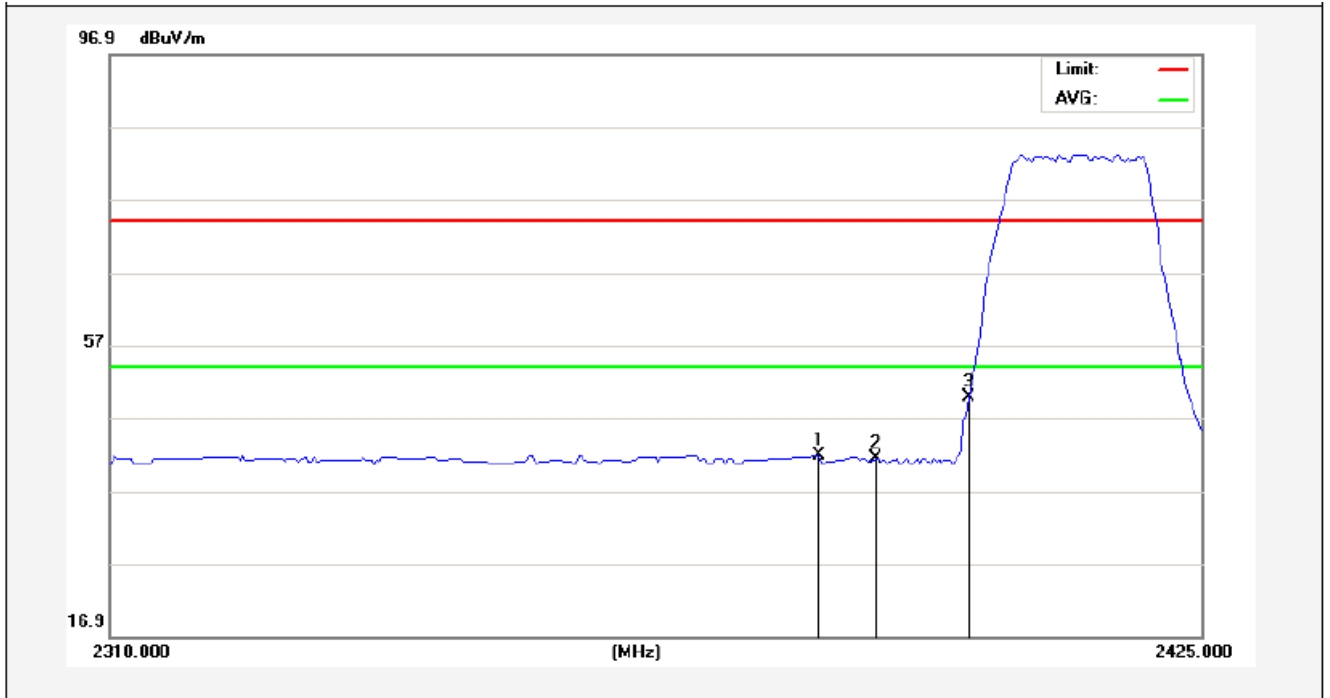

No.	Freq. (MHz)	Reading (dBuV/m)	Factor (dB/m)	Result (dBuV/m)	Limit (dBuV/)	Over Limit (dB)	Detector	Height (cm)	degree (deg)	Remark
1	2384.175	44.32	-2.53	41.79	54.00	-12.21	AVG			
2	2390.000	43.83	-2.51	41.32	54.00	-12.68	AVG			
3	2400.000	52.39	-2.49	49.90	54.00	-4.10	AVG			

Anbotek

Test Mode: 802.11n (HT20)

2462MHz

Horizontal-PEAK:

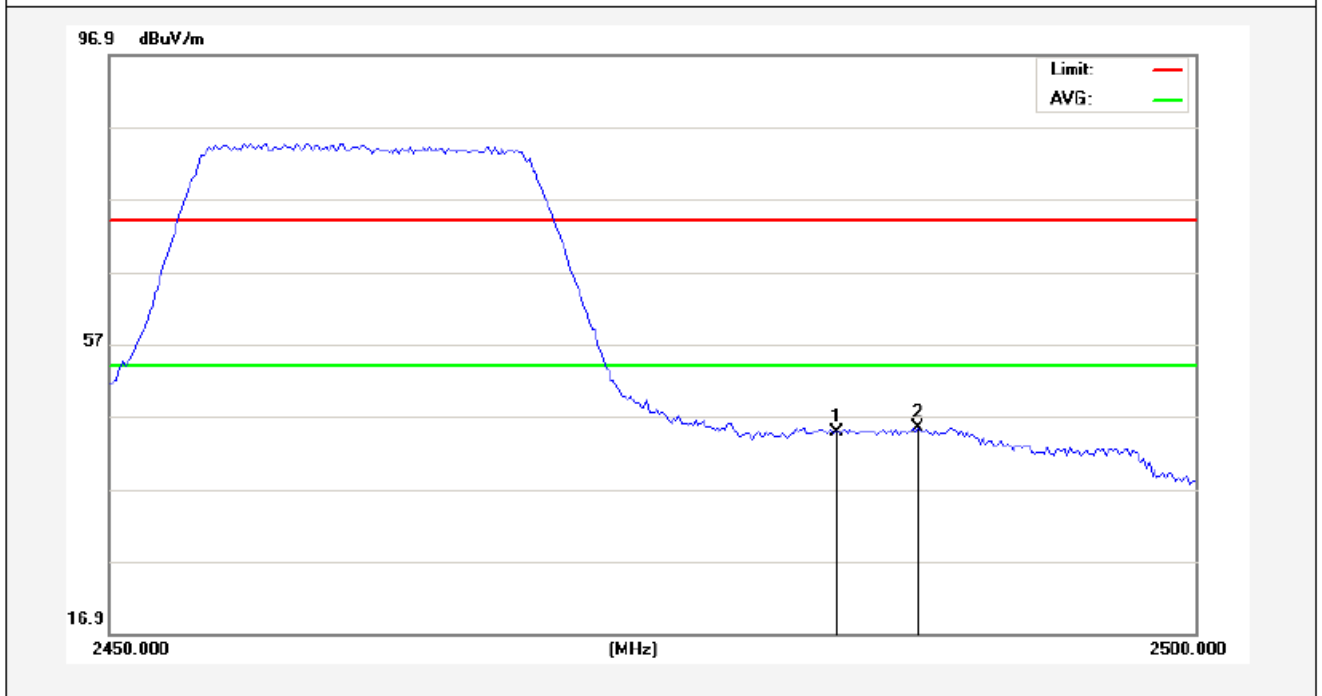

No.	Freq. (MHz)	Reading (dBuV/m)	Factor (dB/m)	Result (dBuV/m)	Limit (dBuV/)	Over Limit (dB)	Detector	Height (cm)	degree (deg)	Remark
1	2483.500	47.12	-2.31	44.81	74.00	-29.19	peak			
2	2487.250	47.70	-2.30	45.40	74.00	-28.60	peak			

Anbotek

Horizontal-AV:

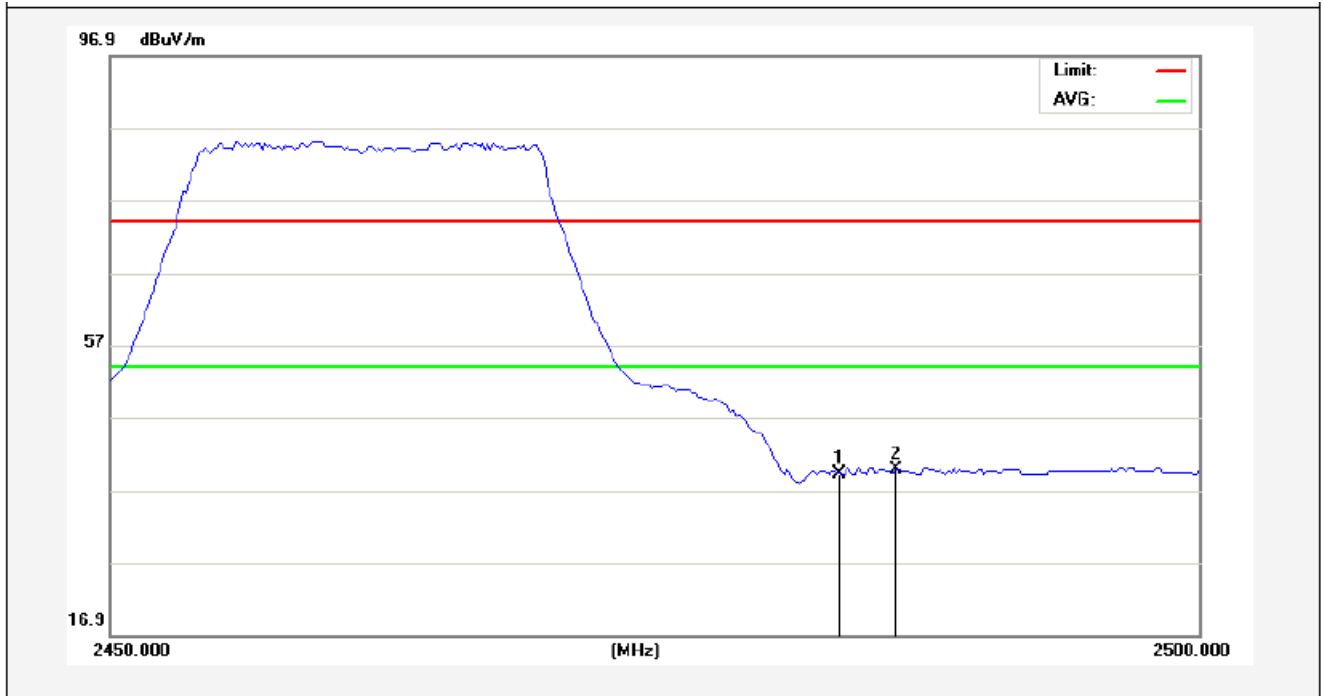

No.	Freq. (MHz)	Reading (dBuV/m)	Factor (dB/m)	Result (dBuV/m)	Limit (dBuV/)	Over Limit (dB)	Detector	Height (cm)	degree (deg)	Remark
1	2483.500	41.61	-2.31	39.30	54.00	-14.70	AVG			
2	2486.125	42.10	-2.30	39.80	54.00	-14.20	AVG			

Anbotek

Test Mode: 802.11n (HT20)

2462MHz

Vertical-PEAK:

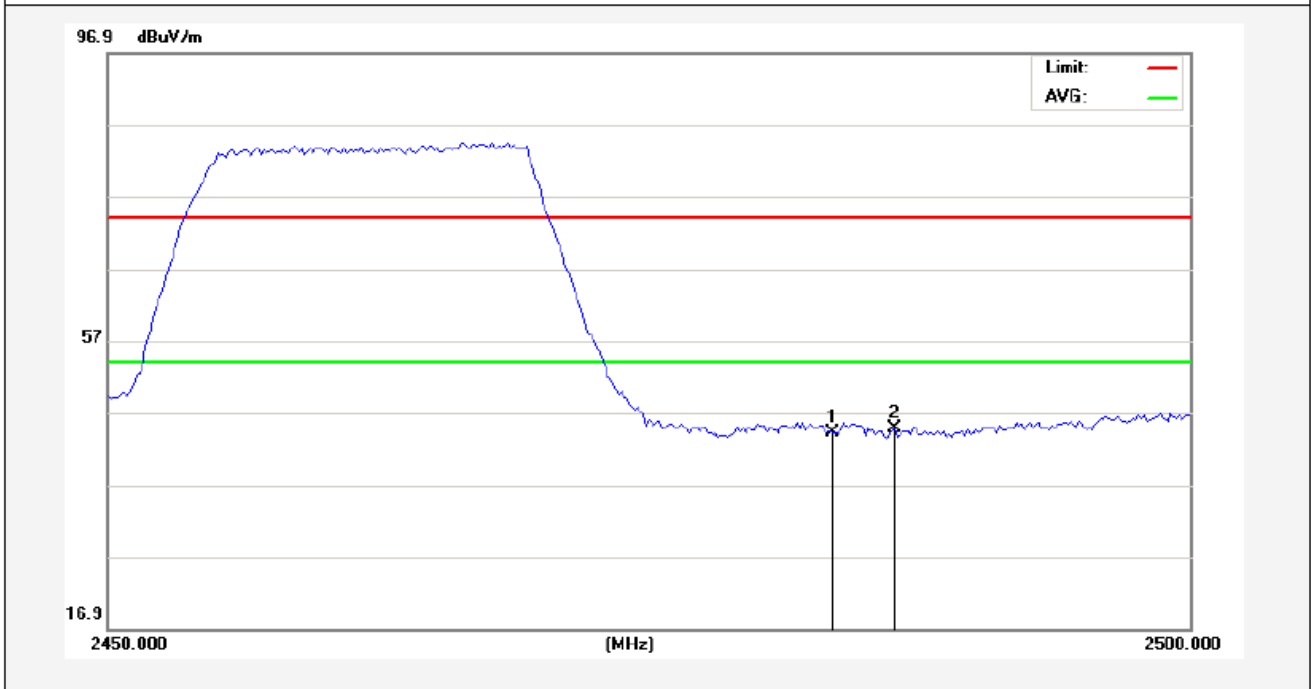

No.	Freq. (MHz)	Reading (dBuV/m)	Factor (dB/m)	Result (dBuV/m)	Limit (dBuV/)	Over Limit (dB)	Detector	Height (cm)	degree (deg)	Remark
1	2483.500	46.59	-2.31	44.28	74.00	-29.72	peak			
2	2486.375	47.07	-2.30	44.77	74.00	-29.23	peak			

Anbotek

Vertical-AV:

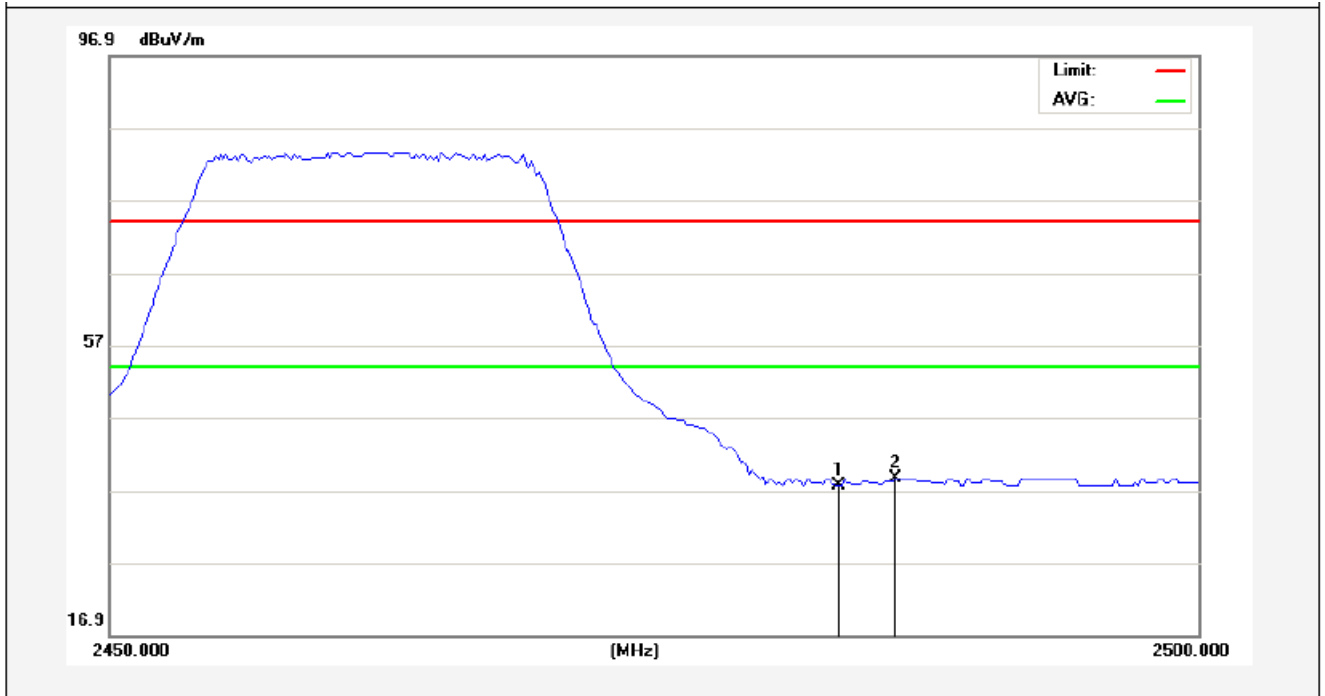

No.	Freq. (MHz)	Reading (dBuV/m)	Factor (dB/m)	Result (dBuV/m)	Limit (dBuV/)	Over Limit (dB)	Detector	Height (cm)	degree (deg)	Remark
1	2483.500	39.97	-2.31	37.66	54.00	-16.34	AVG			
2	2486.125	40.89	-2.30	38.59	54.00	-15.41	AVG			

Anbotek

Test Mode: 802.11n (HT40)

2422MHz

Horizontal-PEAK:

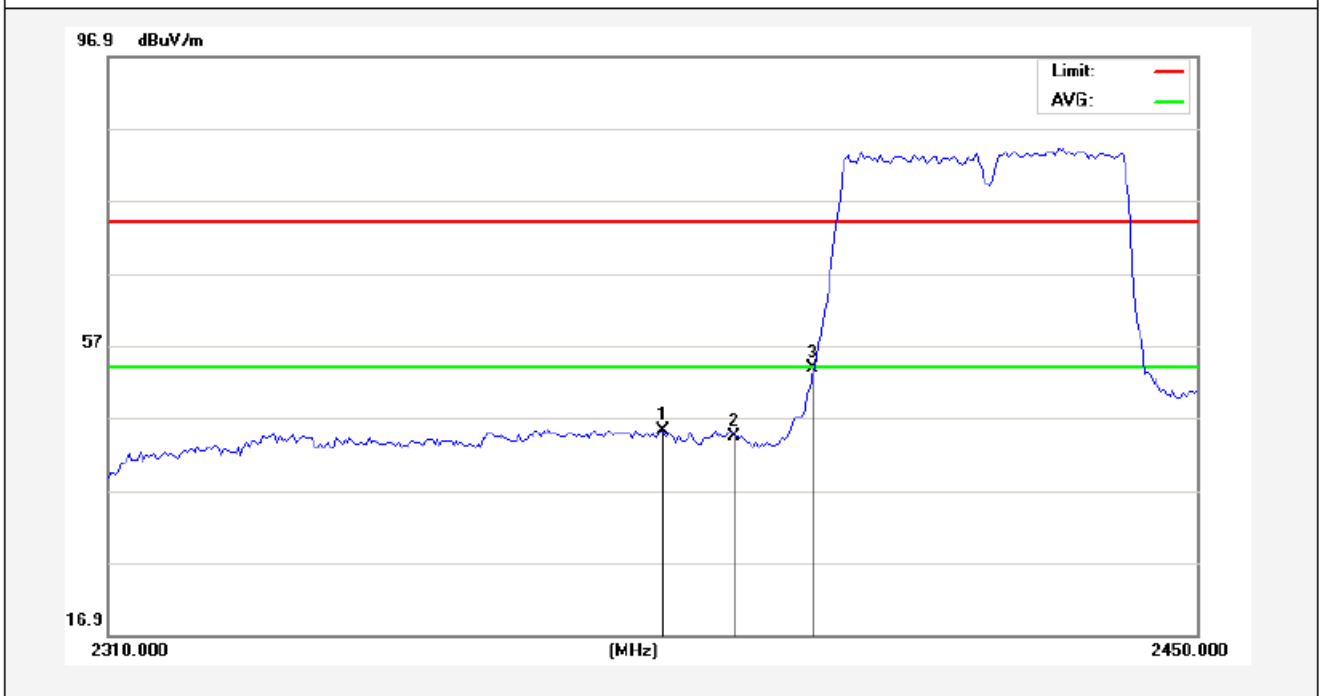

No.	Freq. (MHz)	Reading (dBuV/m)	Factor (dB/m)	Result (dBuV/m)	Limit (dBuV/)	Over Limit (dB)	Detector	Height (cm)	degree (deg)	Remark
1	2380.700	47.67	-2.53	45.14	74.00	-28.86	peak			
2	2390.000	46.96	-2.51	44.45	74.00	-29.55	peak			
3	2400.000	56.22	-2.49	53.73	74.00	-20.27	peak			

Anbotek

Horizontal-AV:

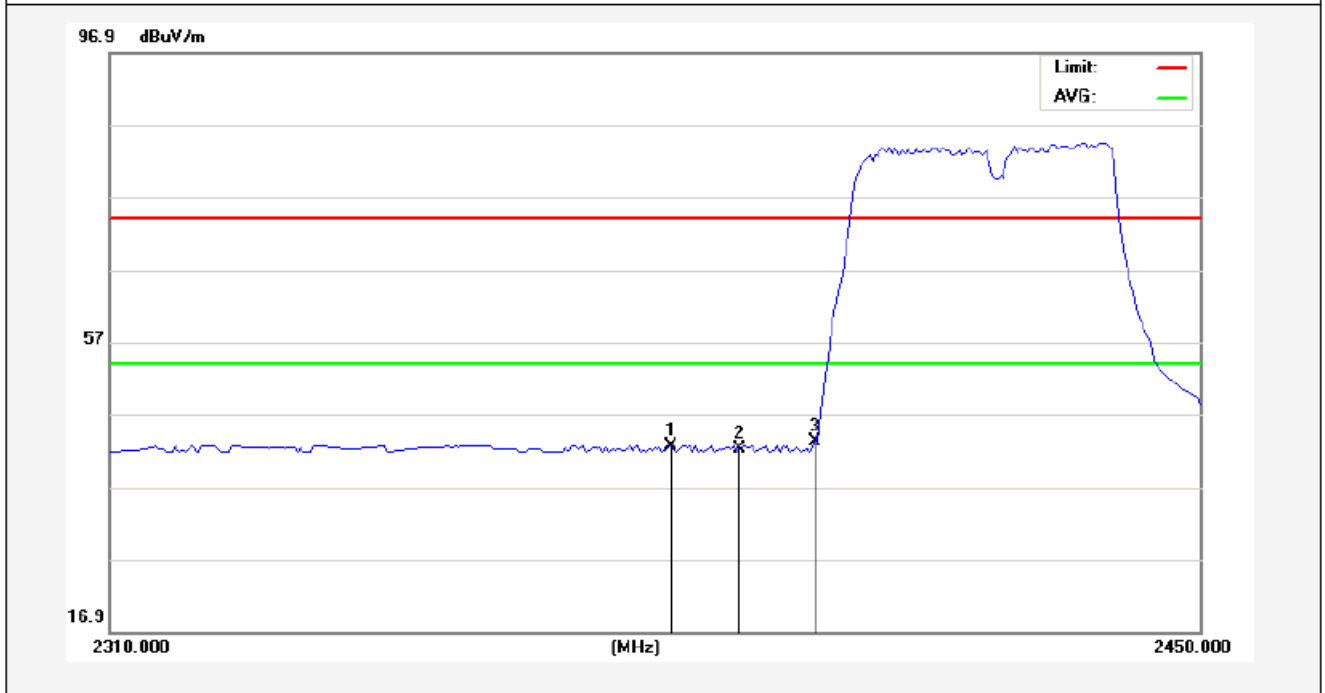

No.	Freq. (MHz)	Reading (dBuV/m)	Factor (dB/m)	Result (dBuV/m)	Limit (dBuV/)	Over Limit (dB)	Detector	Height (cm)	degree (deg)	Remark
1	2381.400	45.19	-2.53	42.66	54.00	-11.34	AVG			
2	2390.000	44.64	-2.51	42.13	54.00	-11.87	AVG			
3	2400.000	45.66	-2.49	43.17	54.00	-10.83	AVG			

Anbotek

Test Mode: 802.11n (HT40)

2422MHz

Vertical-PEAK:

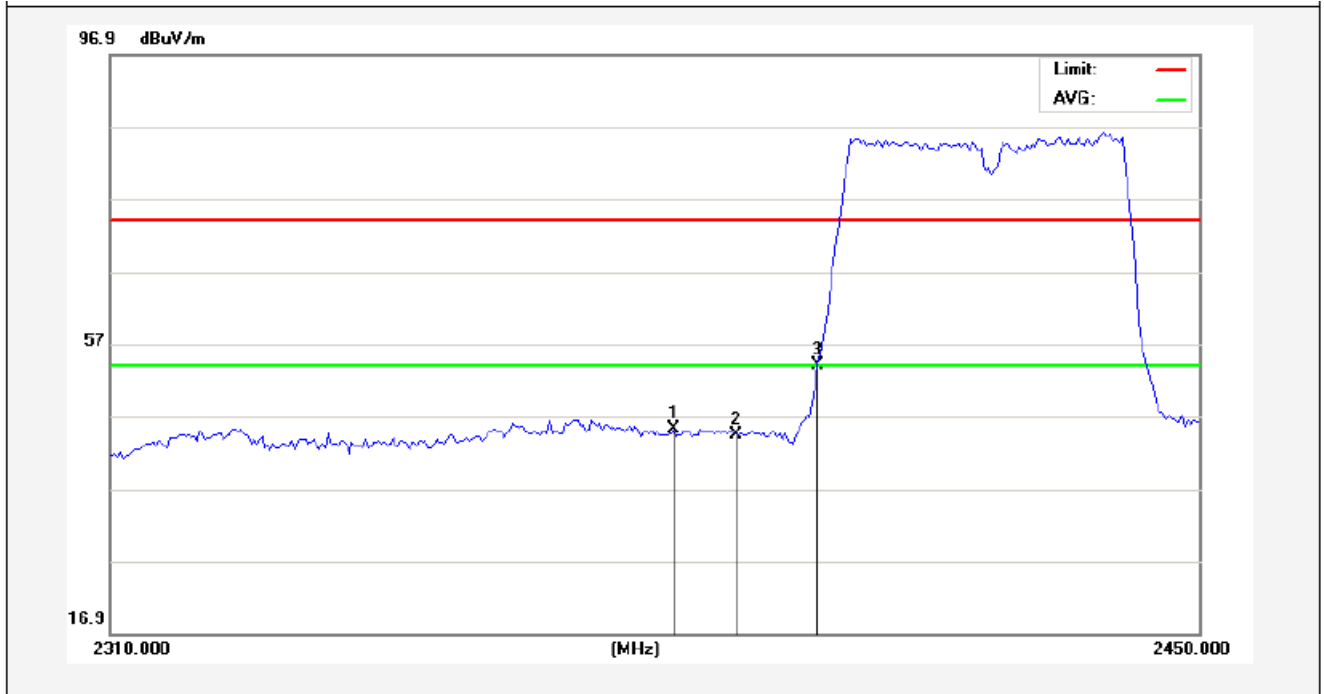

No.	Freq. (MHz)	Reading (dBuV/m)	Factor (dB/m)	Result (dBuV/m)	Limit (dBuV/)	Over Limit (dB)	Detector	Height (cm)	degree (deg)	Remark
1	2381.750	47.71	-2.53	45.18	74.00	-28.82	peak			
2	2390.000	47.01	-2.51	44.50	74.00	-29.50	peak			
3	2400.000	56.51	-2.49	54.02	74.00	-19.98	peak			

Anbotek

Vertical-AV:

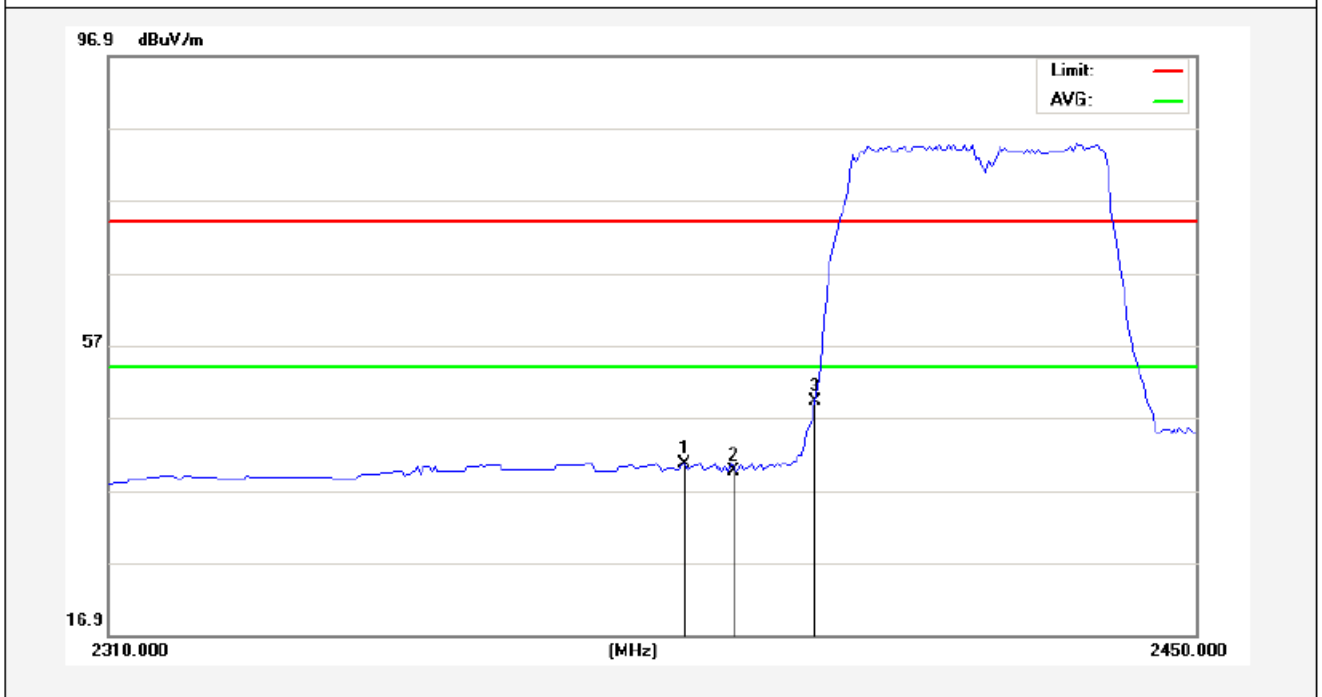

No.	Freq. (MHz)	Reading (dBuV/m)	Factor (dB/m)	Result (dBuV/m)	Limit (dBuV/)	Over Limit (dB)	Detector	Height (cm)	degree (deg)	Remark
1	2383.500	43.13	-2.53	40.60	54.00	-13.40	AVG			
2	2390.000	42.15	-2.51	39.64	54.00	-14.36	AVG			
3	2400.000	51.64	-2.49	49.15	54.00	-4.85	AVG			

Anbotek

Test Mode: 802.11n (HT40)

2452MHz

Horizontal-PEAK:

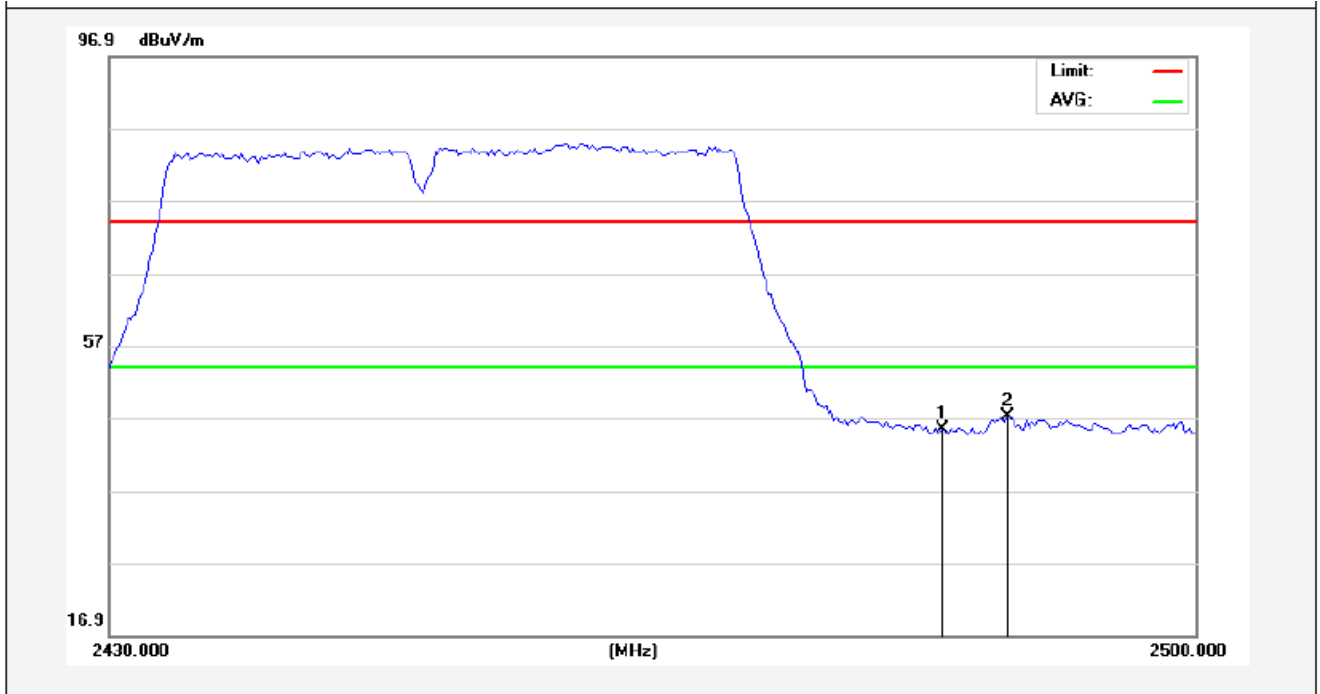

No.	Freq. (MHz)	Reading (dBuV/m)	Factor (dB/m)	Result (dBuV/m)	Limit (dBuV/)	Over Limit (dB)	Detector	Height (cm)	degree (deg)	Remark
1	2483.500	47.81	-2.31	45.50	74.00	-28.50	peak			
2	2487.925	49.51	-2.30	47.21	74.00	-26.79	peak			

Anbotek

Horizontal-AV:

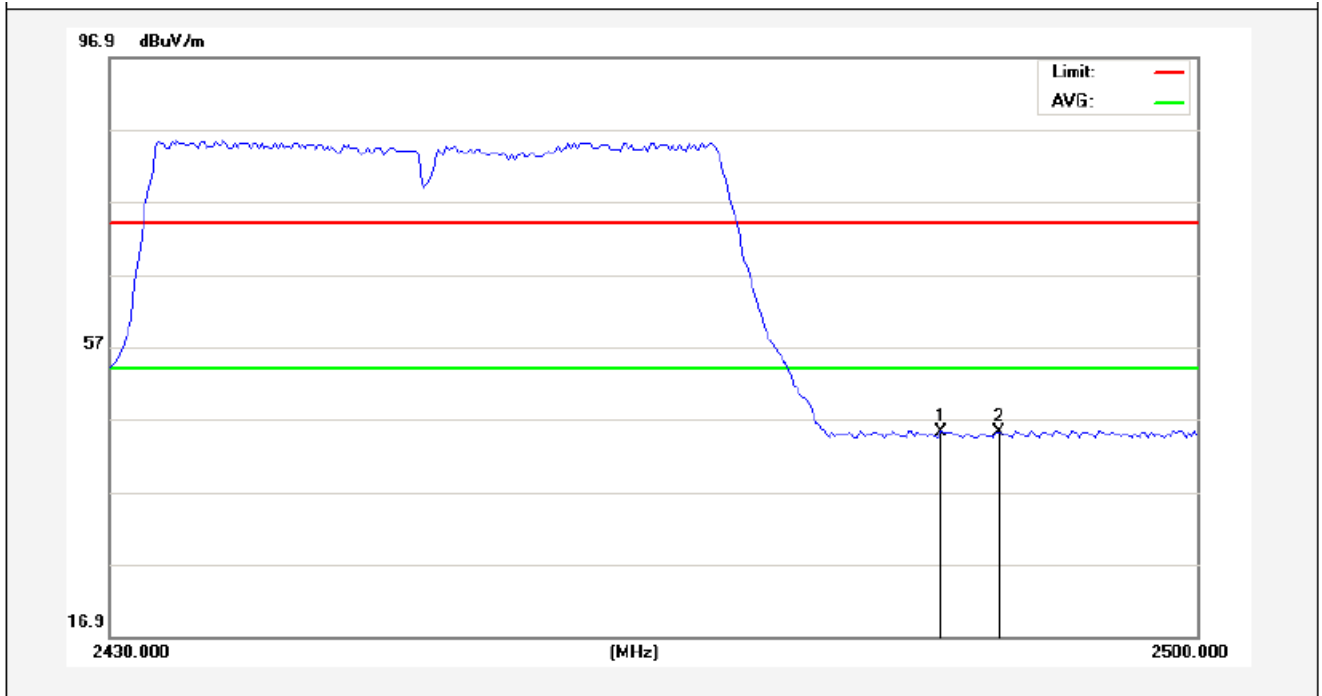

No.	Freq. (MHz)	Reading (dBuV/m)	Factor (dB/m)	Result (dBuV/m)	Limit (dBuV/)	Over Limit (dB)	Detector	Height (cm)	degree (deg)	Remark
1	2483.500	47.60	-2.31	45.29	54.00	-8.71	AVG			
2	2487.225	47.46	-2.30	45.16	54.00	-8.84	AVG			

Anbotek

Test Mode: 802.11n (HT40)

2452MHz

Vertical-PEAK:

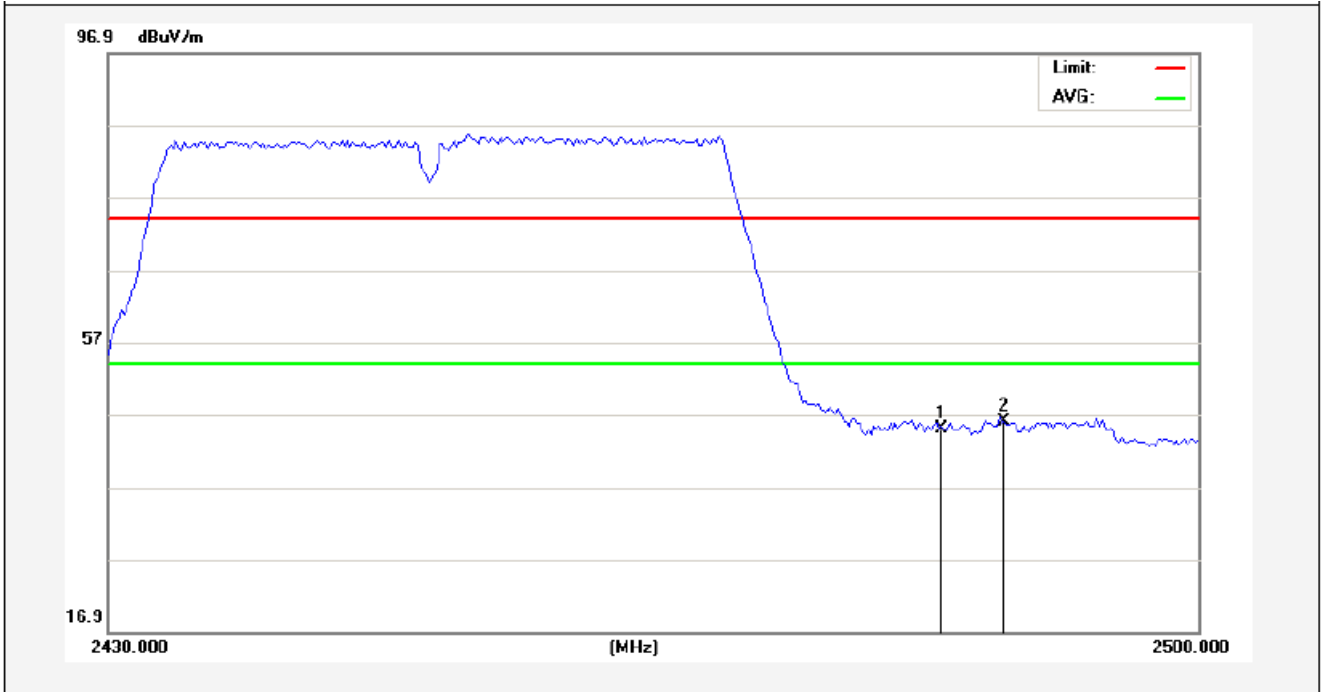

No.	Freq. (MHz)	Reading (dBuV/m)	Factor (dB/m)	Result (dBuV/m)	Limit (dBuV/)	Over Limit (dB)	Detector	Height (cm)	degree (deg)	Remark
1	2483.500	47.23	-2.31	44.92	74.00	-29.08	peak			
2	2487.575	48.35	-2.30	46.05	74.00	-27.95	peak			

Anbotek

Vertical-AV:

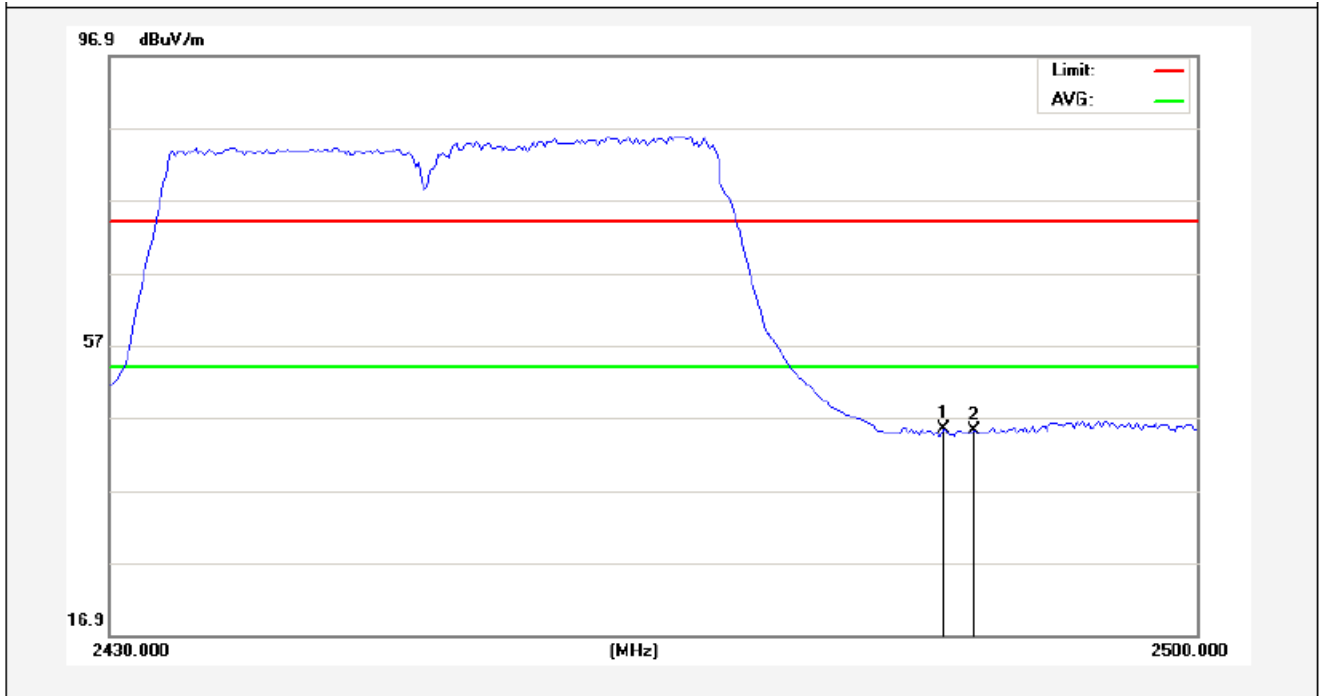

No.	Freq. (MHz)	Reading (dBuV/m)	Factor (dB/m)	Result (dBuV/m)	Limit (dBuV/)	Over Limit (dB)	Detector	Height (cm)	degree (deg)	Remark
1	2483.500	47.70	-2.31	45.39	54.00	-8.61	AVG			
2	2485.650	47.48	-2.30	45.18	54.00	-8.82	AVG			

Anbotek

ANT B

Test Mode: 802.11b

2412MHz

Horizontal-PEAK:

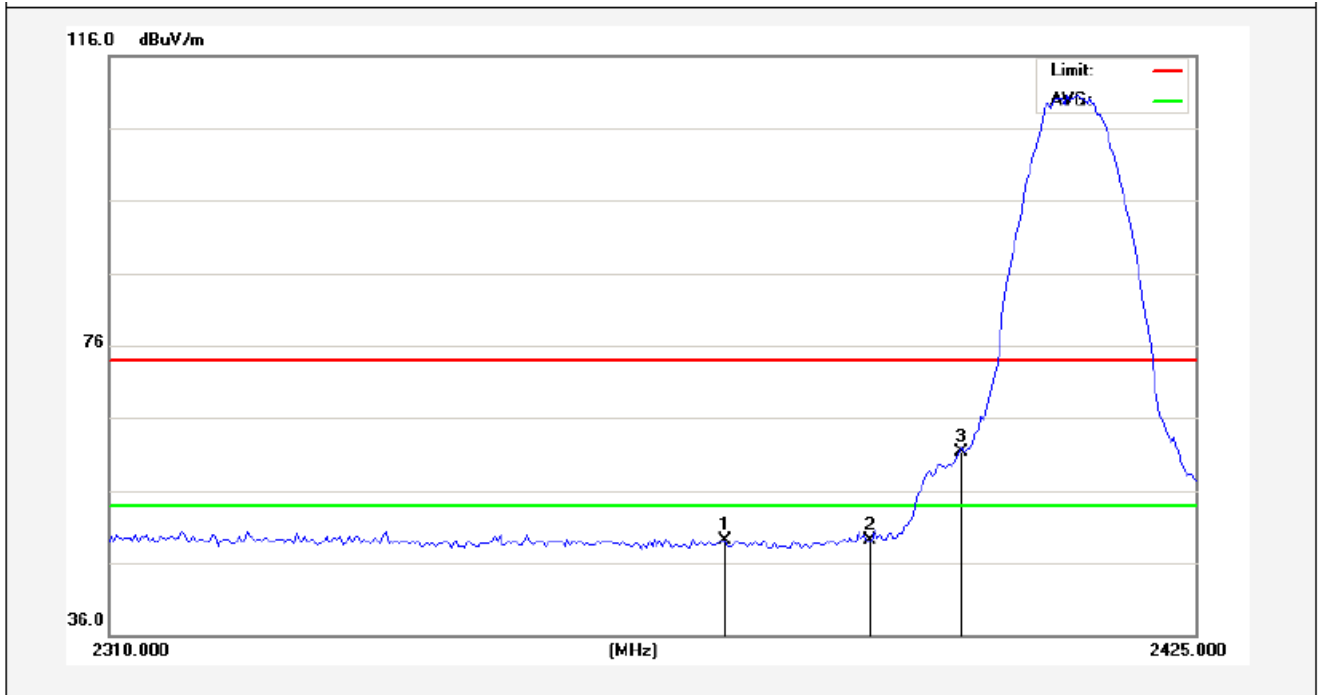

No.	Freq. (MHz)	Reading (dBuV/m)	Factor (dB/m)	Result (dBuV/m)	Limit (dBuV/)	Over Limit (dB)	Detector	Height (cm)	degree (deg)	Remark
1	2374.688	51.73	-2.55	49.18	74.00	-24.82	peak			
2	2390.000	51.66	-2.51	49.15	74.00	-24.85	peak			
3	2400.000	63.89	-2.49	61.40	74.00	-12.60	peak			

ANT B

Horizontal-AV:

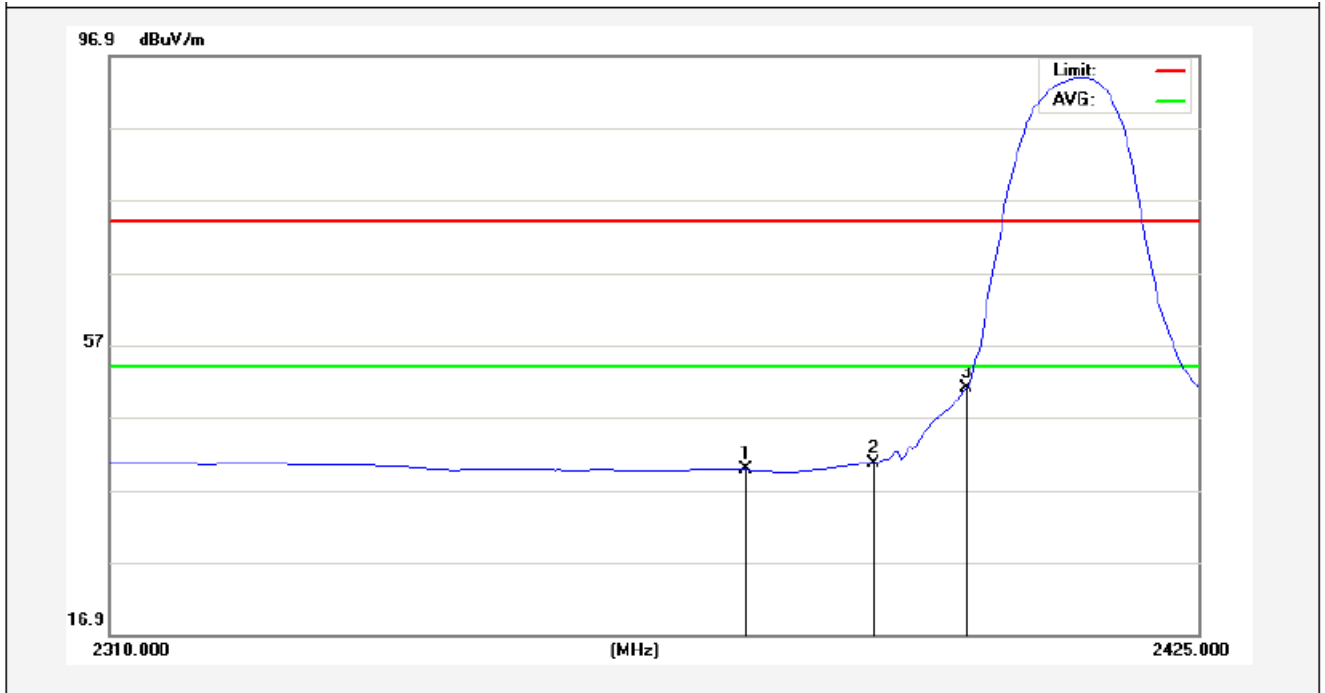

No.	Freq. (MHz)	Reading (dBuV/m)	Factor (dB/m)	Result (dBuV/m)	Limit (dBuV/)	Over Limit (dB)	Detector	Height (cm)	degree (deg)	Remark
1	2376.700	42.27	-2.54	39.73	54.00	-14.27	AVG			
2	2390.000	43.19	-2.51	40.68	54.00	-13.32	AVG			
3	2400.000	53.58	-2.49	51.09	54.00	-2.91	AVG			

Anbotek

Test Mode: 802.11b
2412MHz
Vertical-PEAK:

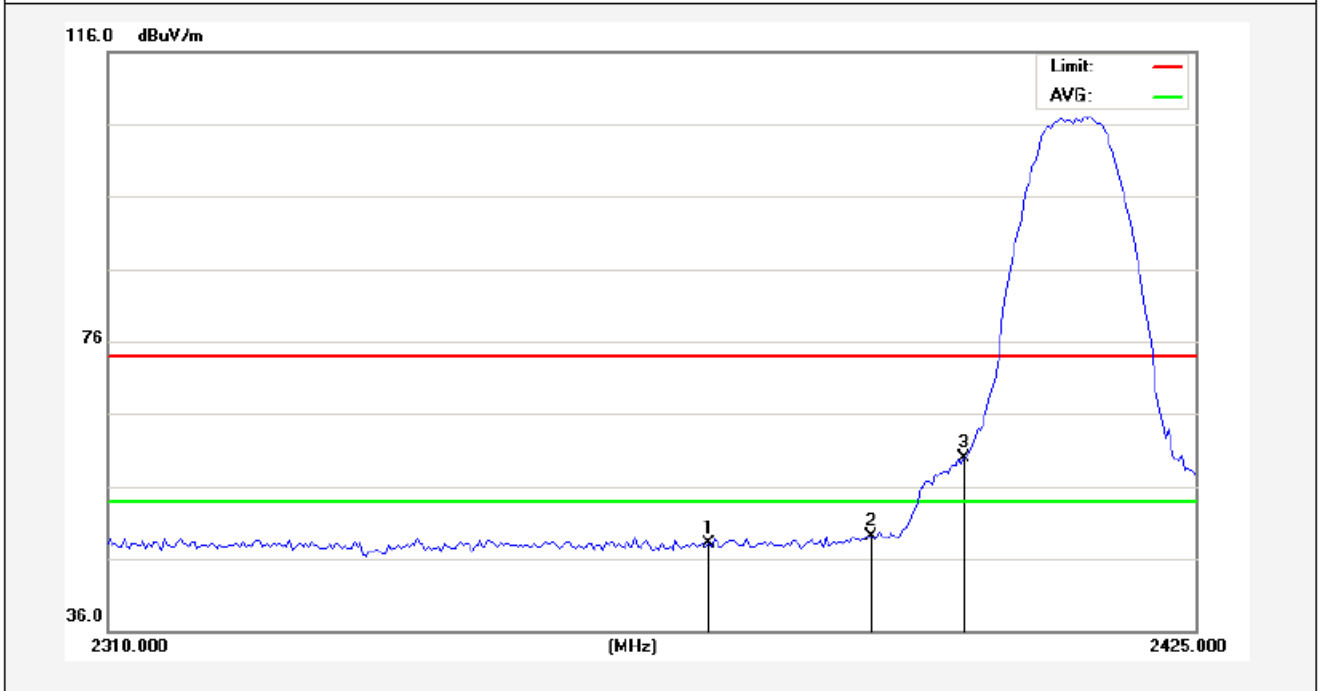

No.	Freq. (MHz)	Reading (dBuV/m)	Factor (dB/m)	Result (dBuV/m)	Limit (dBuV/)	Over Limit (dB)	Detector	Height (cm)	degree (deg)	Remark
1	2372.963	50.59	-2.55	48.04	74.00	-25.96	peak			
2	2390.000	51.56	-2.51	49.05	74.00	-24.95	peak			
3	2400.000	62.31	-2.49	59.82	74.00	-14.18	peak			

Anbotek

Vertical-AV:

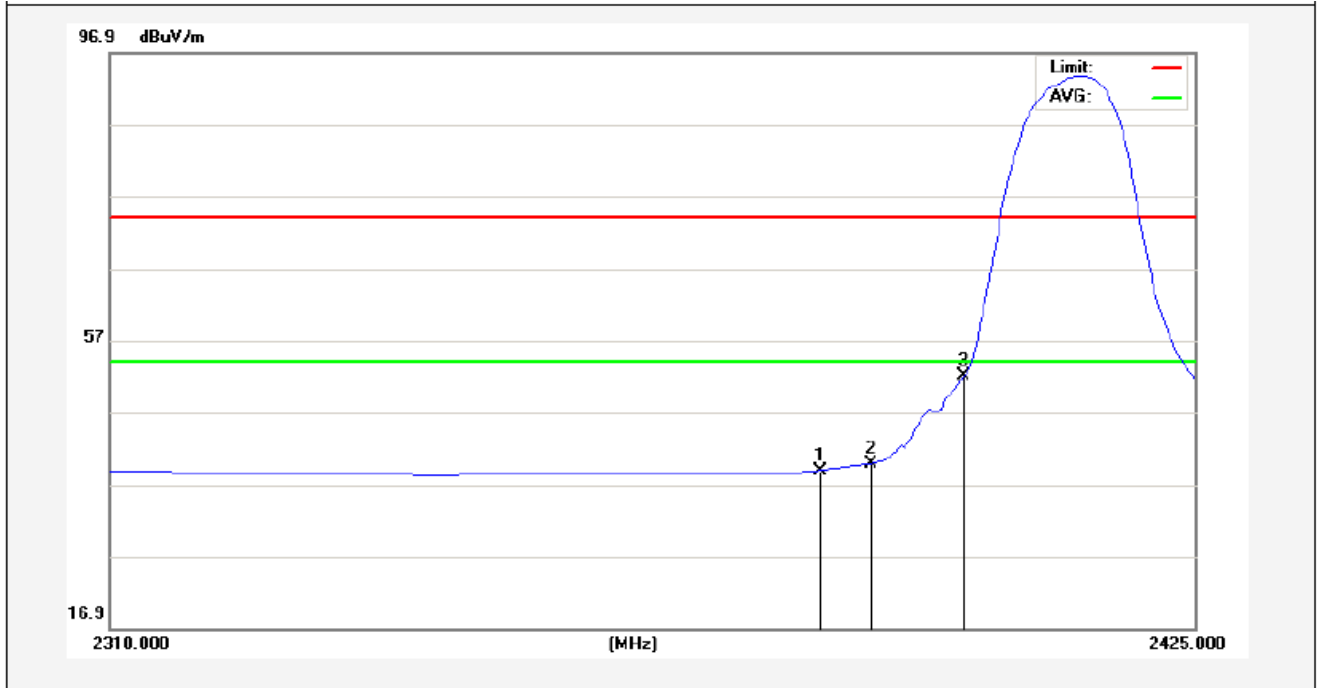

No.	Freq. (MHz)	Reading (dBuV/m)	Factor (dB/m)	Result (dBuV/m)	Limit (dBuV/)	Over Limit (dB)	Detector	Height (cm)	degree (deg)	Remark
1	2384.463	41.42	-2.53	38.89	54.00	-15.11	AVG			
2	2390.000	42.40	-2.51	39.89	54.00	-14.11	AVG			
3	2400.000	54.43	-2.49	51.94	54.00	-2.06	AVG			

Anbotek

Test Mode: 802.11b
2462MHz
Horizontal-PEAK:

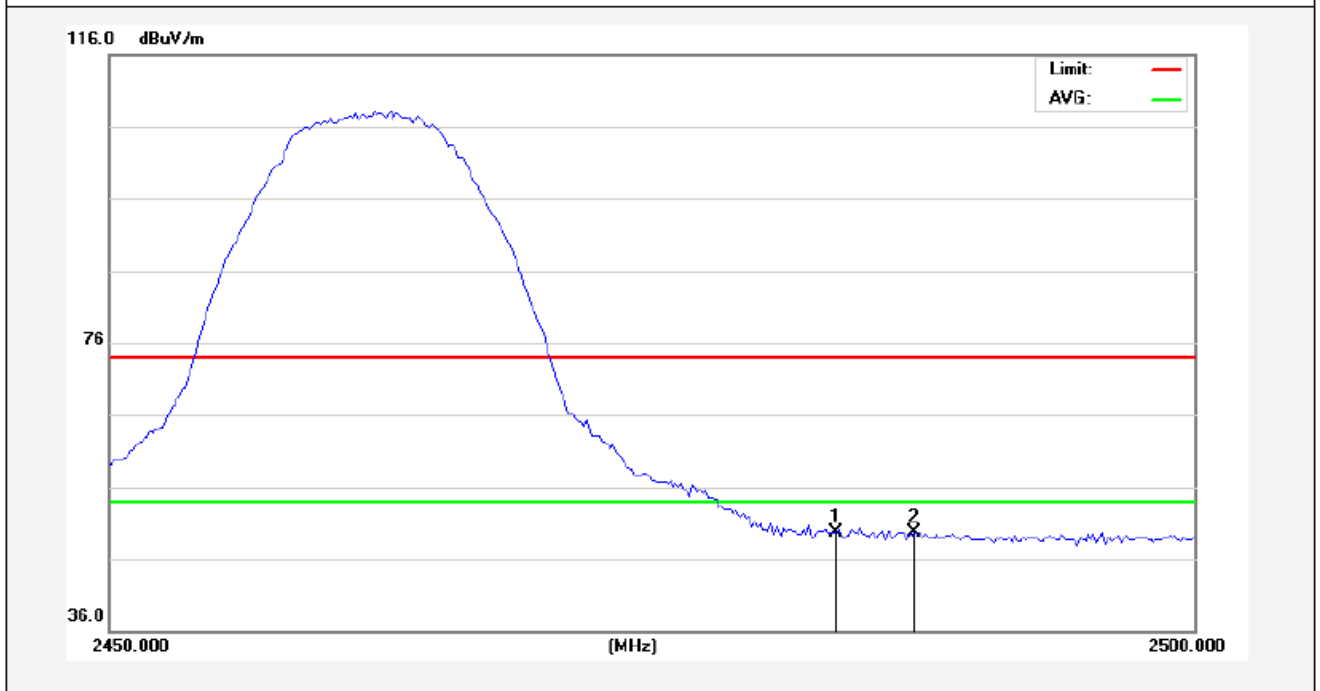

No.	Freq. (MHz)	Reading (dBuV/m)	Factor (dB/m)	Result (dBuV/m)	Limit (dBuV/)	Over Limit (dB)	Detector	Height (cm)	degree (deg)	Remark
1	2483.500	52.10	-2.31	49.79	74.00	-24.21	peak			
2	2487.125	52.07	-2.30	49.77	74.00	-24.23	peak			

Anbotek

Horizontal-AV:

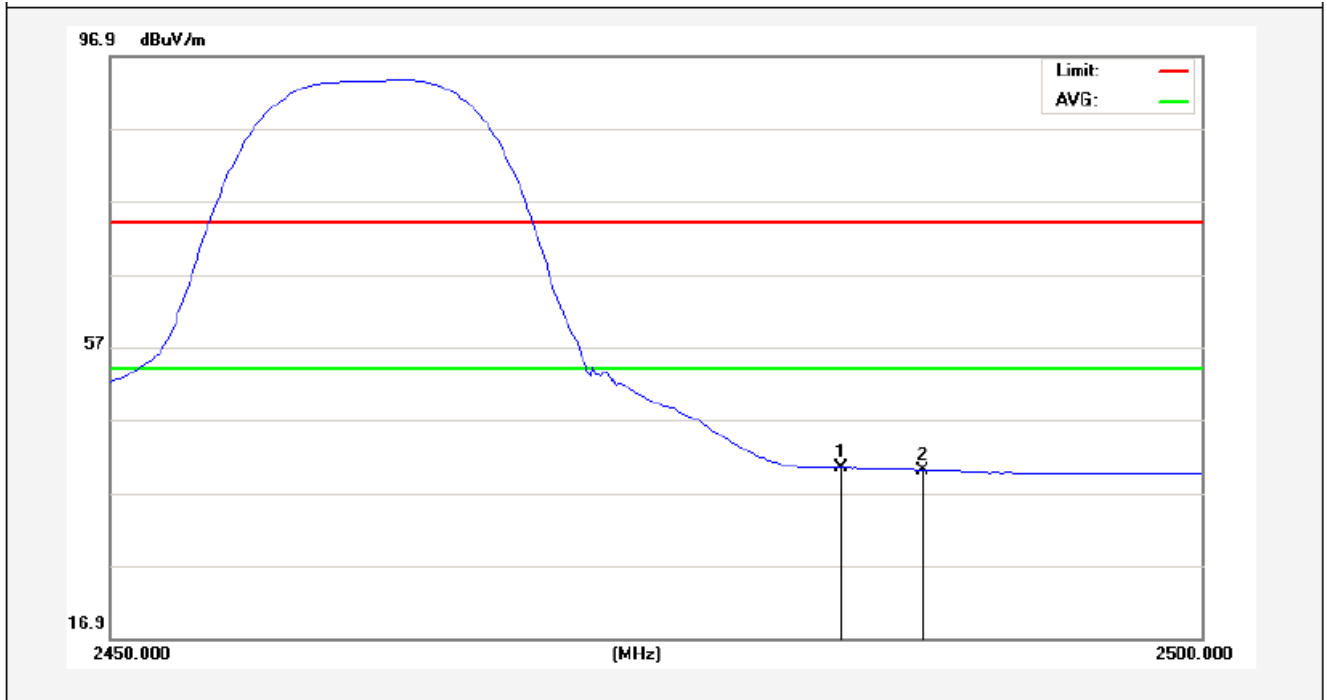

No.	Freq. (MHz)	Reading (dBuV/m)	Factor (dB/m)	Result (dBuV/m)	Limit (dBuV/)	Over Limit (dB)	Detector	Height (cm)	degree (deg)	Remark
1	2483.500	42.62	-2.31	40.31	54.00	-13.69	AVG			
2	2487.250	42.37	-2.30	40.07	54.00	-13.93	AVG			

Anbotek

Test Mode: 802.11b
2462MHz
Vertical-PEAK:

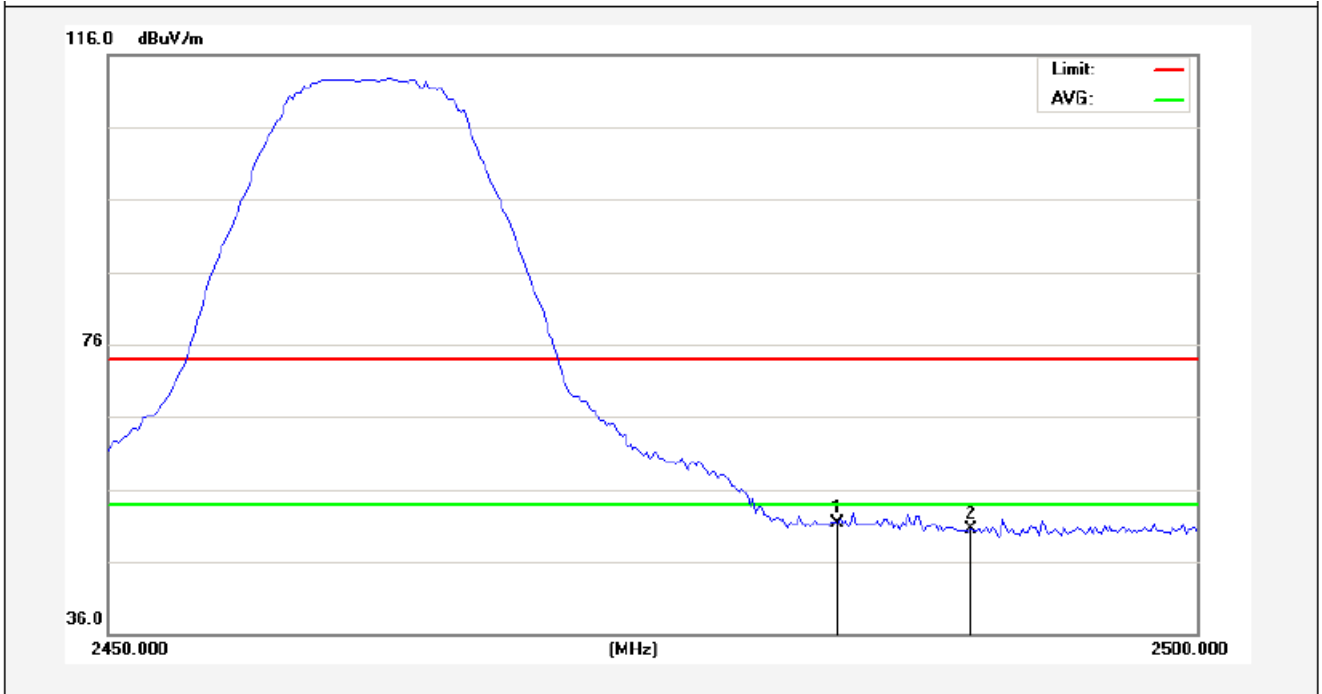

No.	Freq. (MHz)	Reading (dBuV/m)	Factor (dB/m)	Result (dBuV/m)	Limit (dBuV/)	Over Limit (dB)	Detector	Height (cm)	degree (deg)	Remark
1	2483.500	53.56	-2.31	51.25	74.00	-22.75	peak			
2	2489.625	52.87	-2.29	50.58	74.00	-23.42	peak			

Anbotek

Vertical-AV:

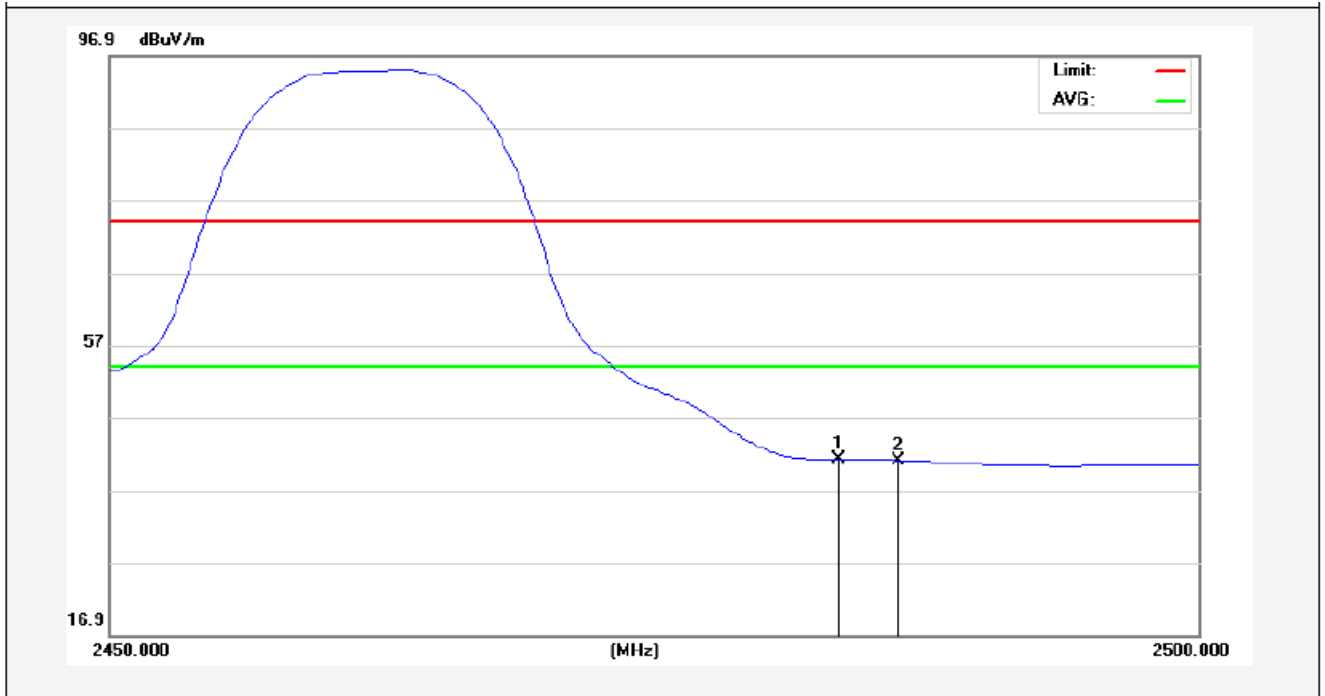

No.	Freq. (MHz)	Reading (dBuV/m)	Factor (dB/m)	Result (dBuV/m)	Limit (dBuV/)	Over Limit (dB)	Detector	Height (cm)	degree (deg)	Remark
1	2483.500	43.55	-2.31	41.24	54.00	-12.76	AVG			
2	2486.250	43.37	-2.30	41.07	54.00	-12.93	AVG			

Anbotek

Test Mode: 802.11g
2412MHz
Horizontal-PEAK:

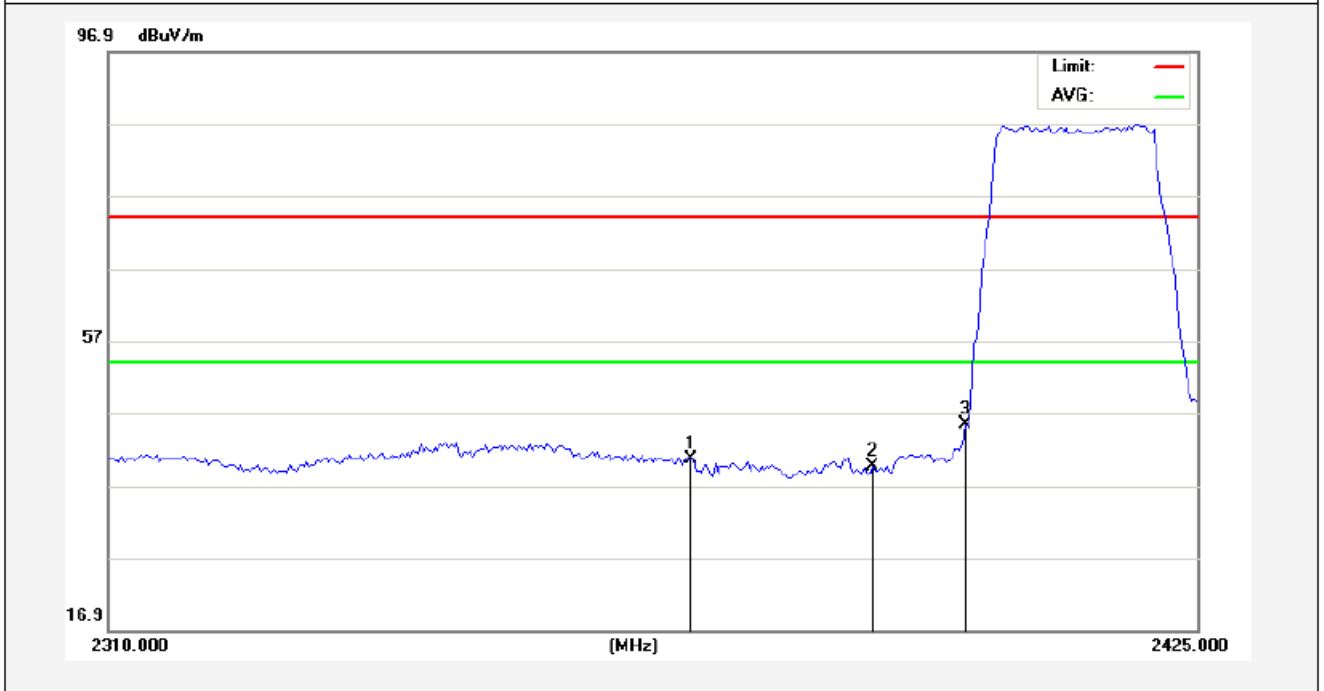

No.	Freq. (MHz)	Reading (dBuV/m)	Factor (dB/m)	Result (dBuV/m)	Limit (dBuV/)	Over Limit (dB)	Detector	Height (cm)	degree (deg)	Remark
1	2370.950	43.09	-2.56	40.53	74.00	-33.47	peak			
2	2390.000	42.07	-2.51	39.56	74.00	-34.44	peak			
3	2400.000	47.86	-2.49	45.37	74.00	-28.63	peak			

Anbotek

Horizontal-AV:

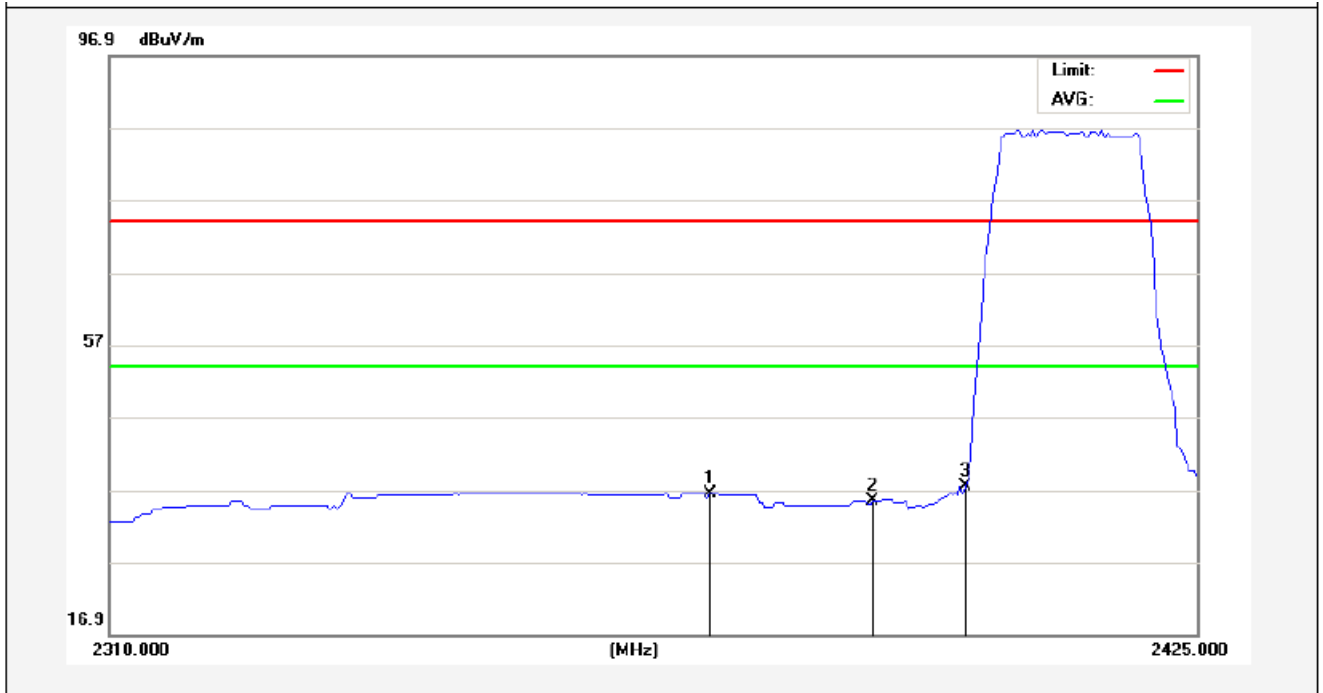

No.	Freq. (MHz)	Reading (dBuV/m)	Factor (dB/m)	Result (dBuV/m)	Limit (dBuV/)	Over Limit (dB)	Detector	Height (cm)	degree (deg)	Remark
1	2372.963	38.88	-2.55	36.33	54.00	-17.67	AVG			
2	2390.000	37.94	-2.51	35.43	54.00	-18.57	AVG			
3	2400.000	39.95	-2.49	37.46	54.00	-16.54	AVG			

Anbotek

Test Mode: 802.11g
2412MHz
Vertical-PEAK:

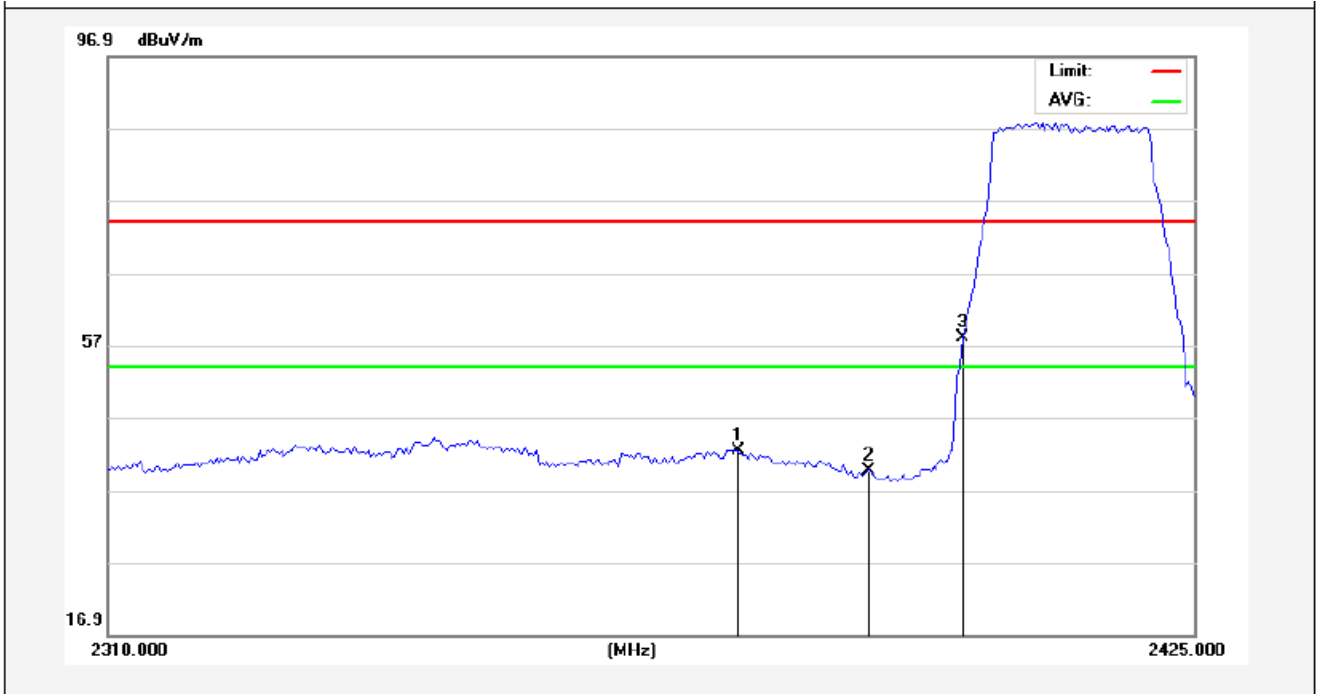

No.	Freq. (MHz)	Reading (dBuV/m)	Factor (dB/m)	Result (dBuV/m)	Limit (dBuV/)	Over Limit (dB)	Detector	Height (cm)	degree (deg)	Remark
1	2376.125	44.92	-2.54	42.38	74.00	-31.62	peak			
2	2390.000	42.11	-2.51	39.60	74.00	-34.40	peak			
3	2400.000	60.40	-2.49	57.91	74.00	-16.09	peak			

Anbotek

Vertical-AV:

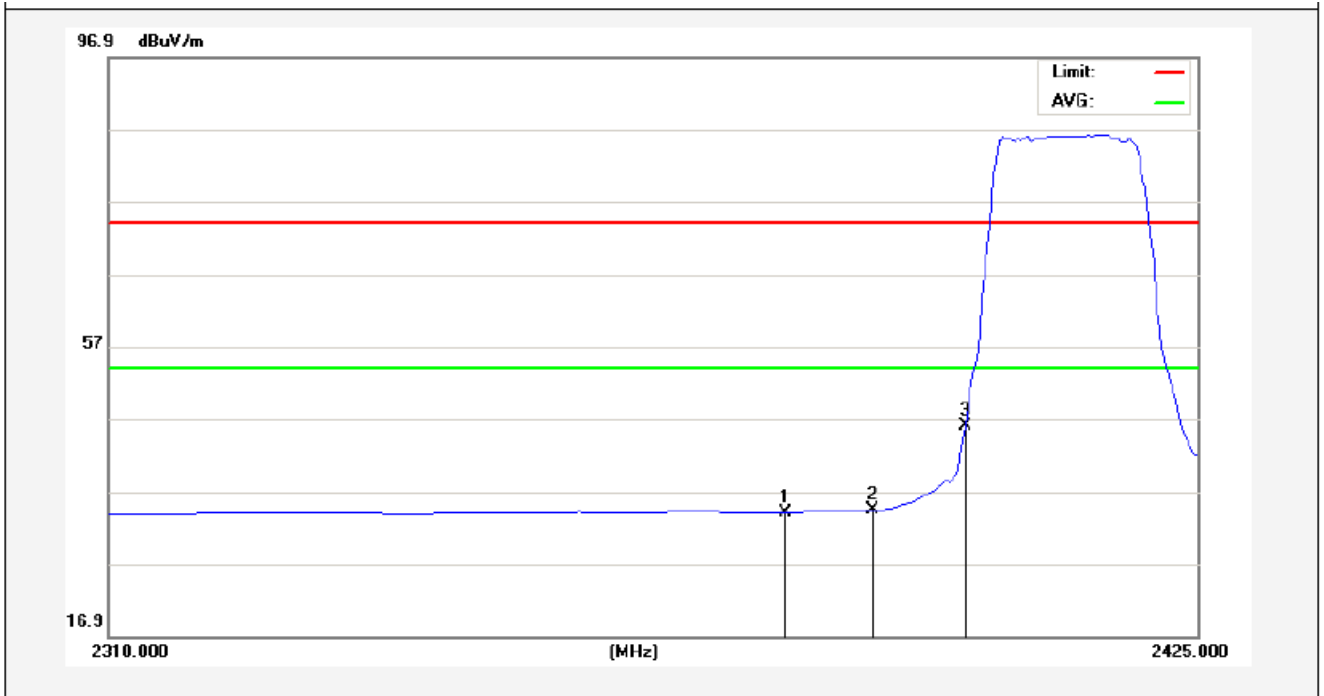

No.	Freq. (MHz)	Reading (dBuV/m)	Factor (dB/m)	Result (dBuV/m)	Limit (dBuV/)	Over Limit (dB)	Detector	Height (cm)	degree (deg)	Remark
1	2381.012	36.58	-2.53	34.05	54.00	-19.95	AVG			
2	2390.000	36.82	-2.51	34.31	54.00	-19.69	AVG			
3	2400.000	48.56	-2.49	46.07	54.00	-7.93	AVG			

Anbotek

Test Mode: 802.11g
2462MHz
Horizontal-PEAK:

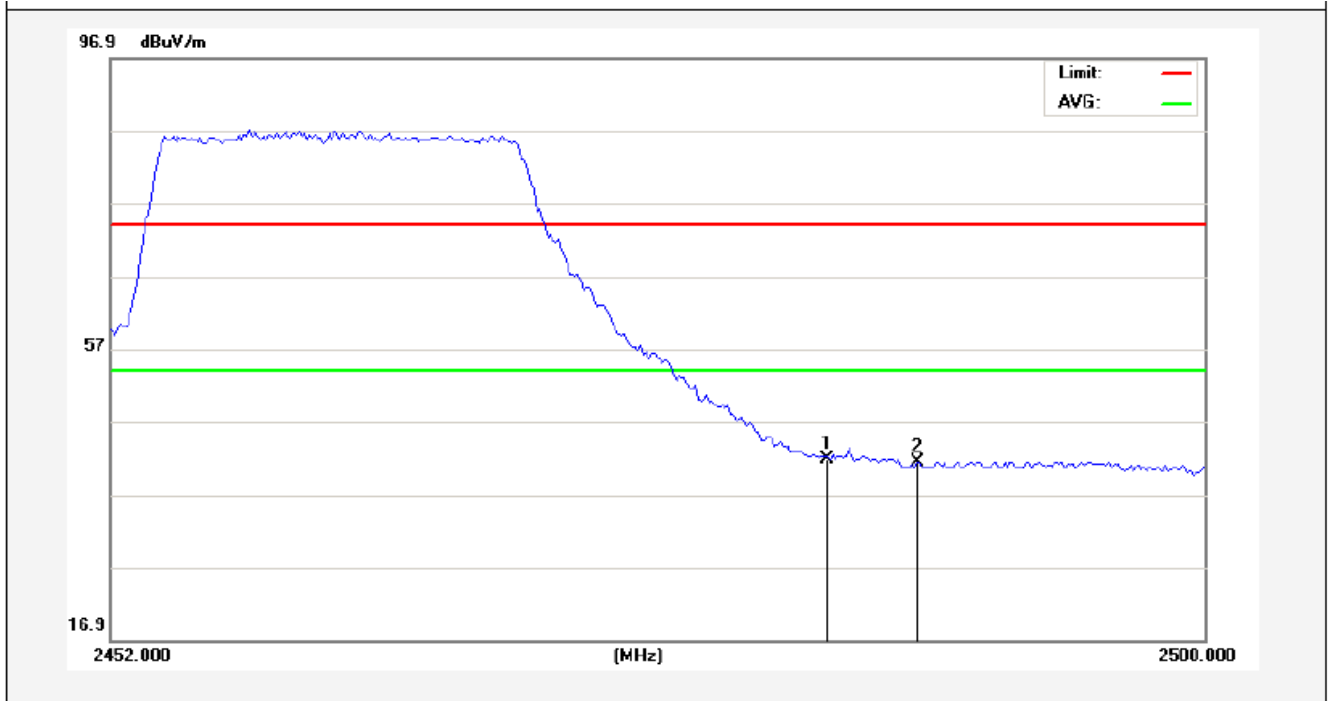

No.	Freq. (MHz)	Reading (dBuV/m)	Factor (dB/m)	Result (dBuV/m)	Limit (dBuV/)	Over Limit (dB)	Detector	Height (cm)	degree (deg)	Remark
1	2483.500	44.14	-2.31	41.83	74.00	-32.17	peak			
2	2487.400	43.64	-2.30	41.34	74.00	-32.66	peak			

Anbotek

Horizontal-AV:

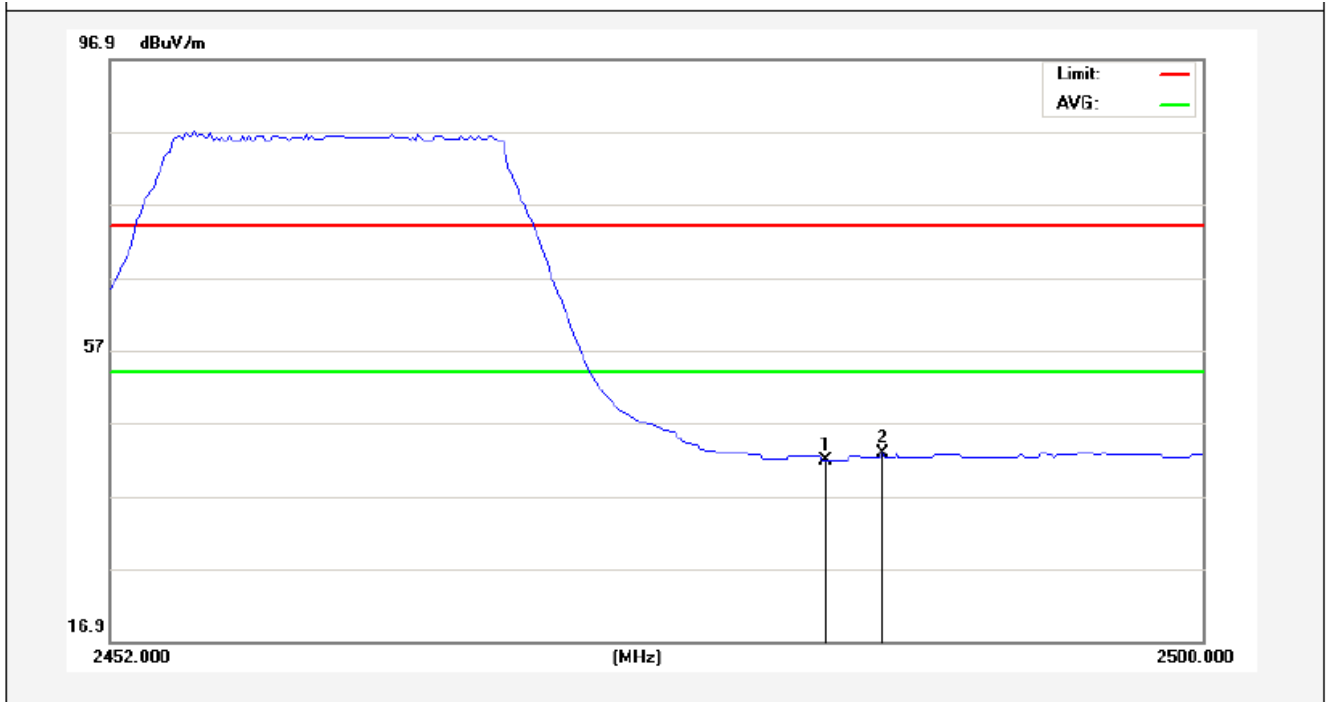

No.	Freq. (MHz)	Reading (dBuV/m)	Factor (dB/m)	Result (dBuV/m)	Limit (dBuV/)	Over Limit (dB)	Detector	Height (cm)	degree (deg)	Remark
1	2483.500	44.17	-2.31	41.86	54.00	-12.14	AVG			
2	2485.960	45.08	-2.30	42.78	54.00	-11.22	AVG			

Test Mode: 802.11g
2462MHz
Vertical-PEAK:

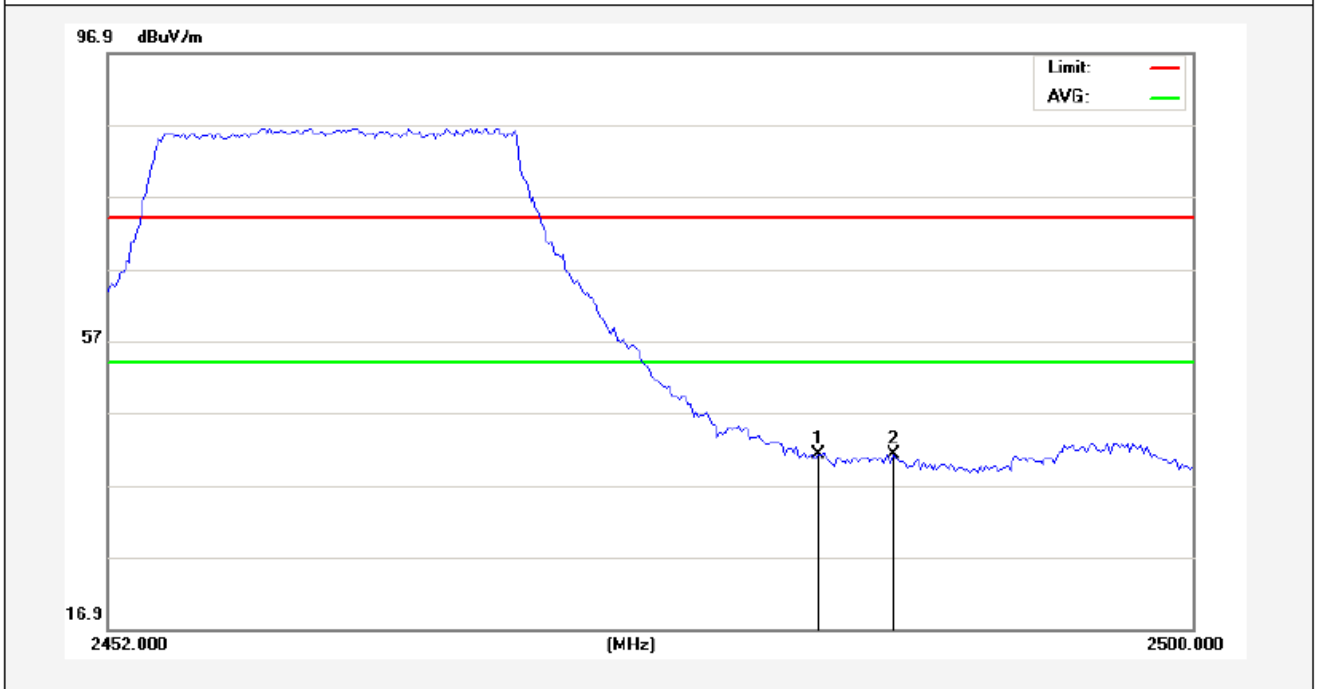

No.	Freq. (MHz)	Reading (dBuV/m)	Factor (dB/m)	Result (dBuV/m)	Limit (dBuV/)	Over Limit (dB)	Detector	Height (cm)	degree (deg)	Remark
1	2483.500	43.54	-2.31	41.23	74.00	-32.77	peak			
2	2486.800	43.49	-2.30	41.19	74.00	-32.81	peak			

Anbotek

Vertical-AV:

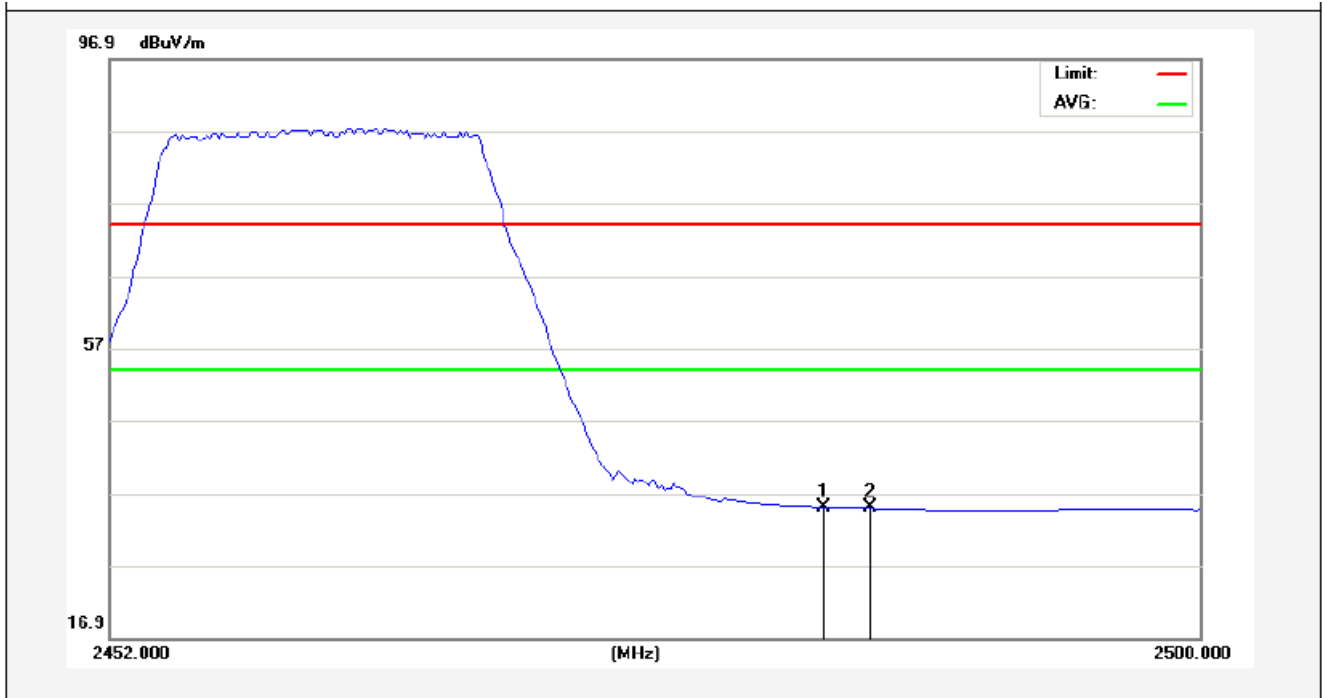

No.	Freq. (MHz)	Reading (dBuV/m)	Factor (dB/m)	Result (dBuV/m)	Limit (dBuV/)	Over Limit (dB)	Detector	Height (cm)	degree (deg)	Remark
1	2483.500	37.35	-2.31	35.04	54.00	-18.96	AVG			
2	2485.480	37.21	-2.30	34.91	54.00	-19.09	AVG			

Anbotek

Test Mode: 802.11n (HT20)

2412MHz

Horizontal-PEAK:

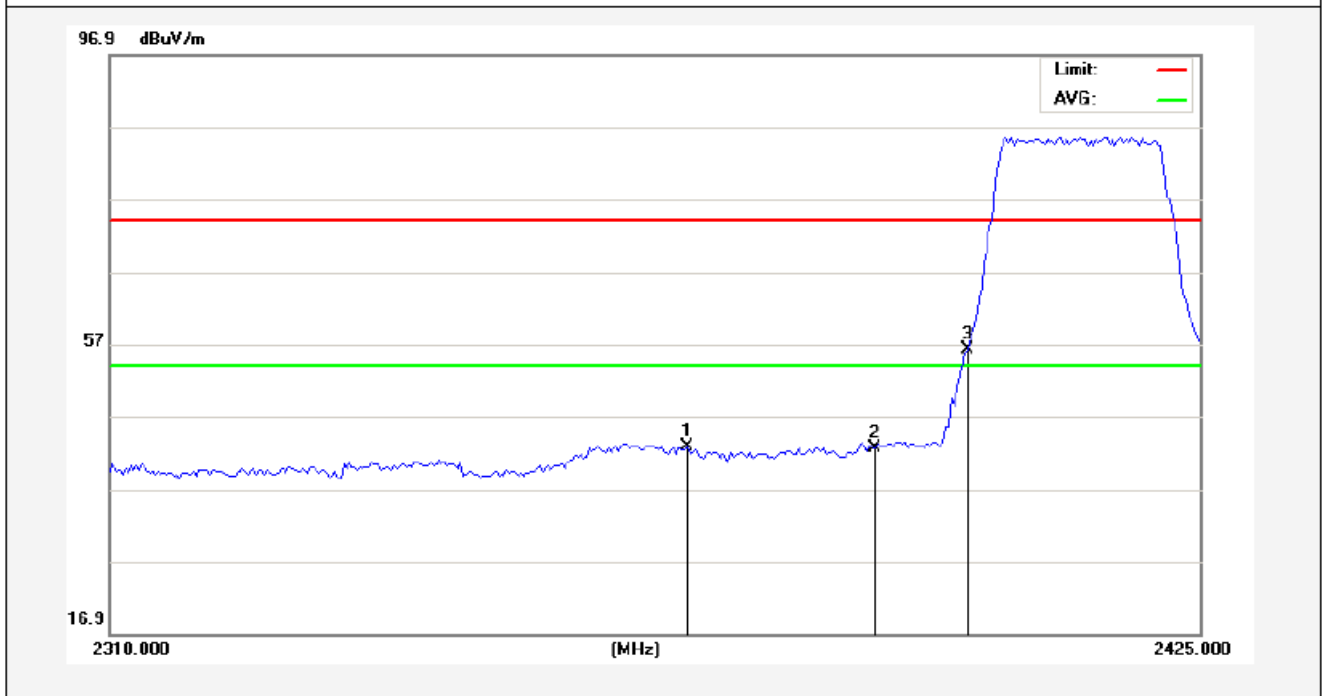

No.	Freq. (MHz)	Reading (dBuV/m)	Factor (dB/m)	Result (dBuV/m)	Limit (dBuV/)	Over Limit (dB)	Detector	Height (cm)	degree (deg)	Remark
1	2370.375	45.30	-2.56	42.74	74.00	-31.26	peak			
2	2390.000	45.20	-2.51	42.69	74.00	-31.31	peak			
3	2400.000	58.74	-2.49	56.25	74.00	-17.75	peak			

Anbotek

Horizontal-AV:

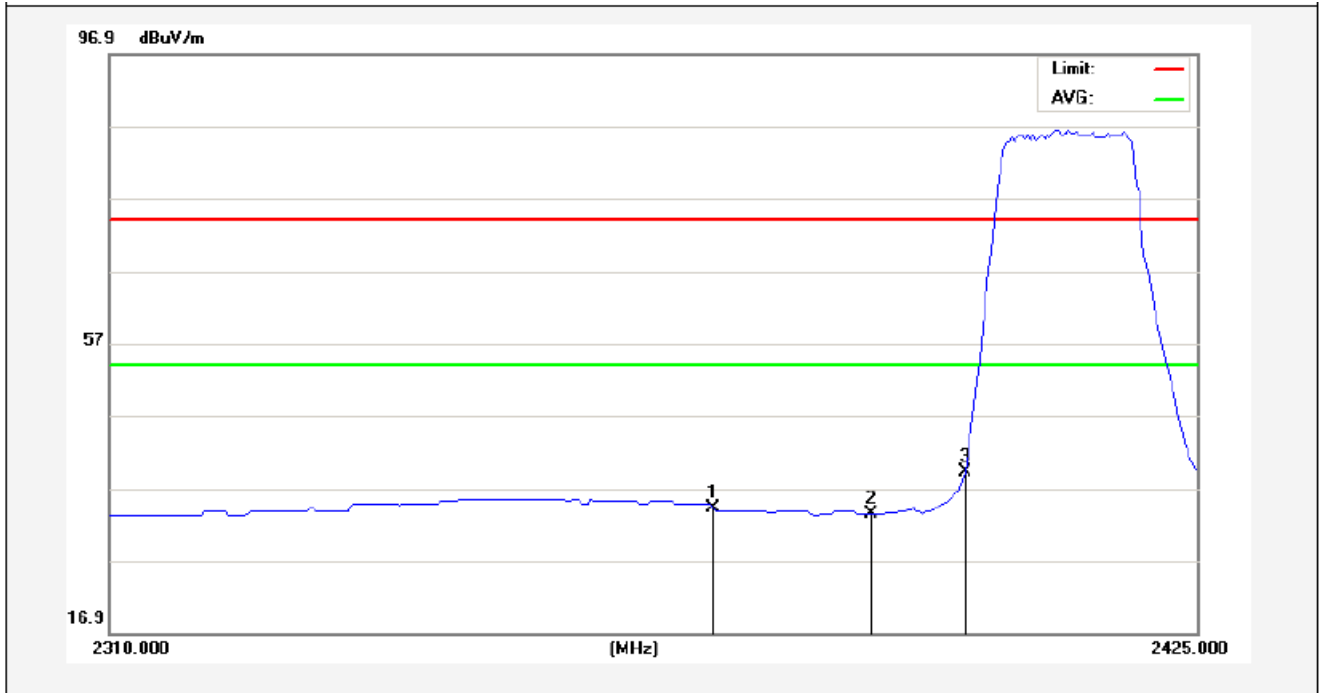

No.	Freq. (MHz)	Reading (dBuV/m)	Factor (dB/m)	Result (dBuV/m)	Limit (dBuV/)	Over Limit (dB)	Detector	Height (cm)	degree (deg)	Remark
1	2373.250	36.83	-2.55	34.28	54.00	-19.72	AVG			
2	2390.000	35.91	-2.51	33.40	54.00	-20.60	AVG			
3	2400.000	41.63	-2.49	39.14	54.00	-14.86	AVG			

Anbotek

Test Mode: 802.11n (HT20)

2412MHz

Vertical-PEAK:

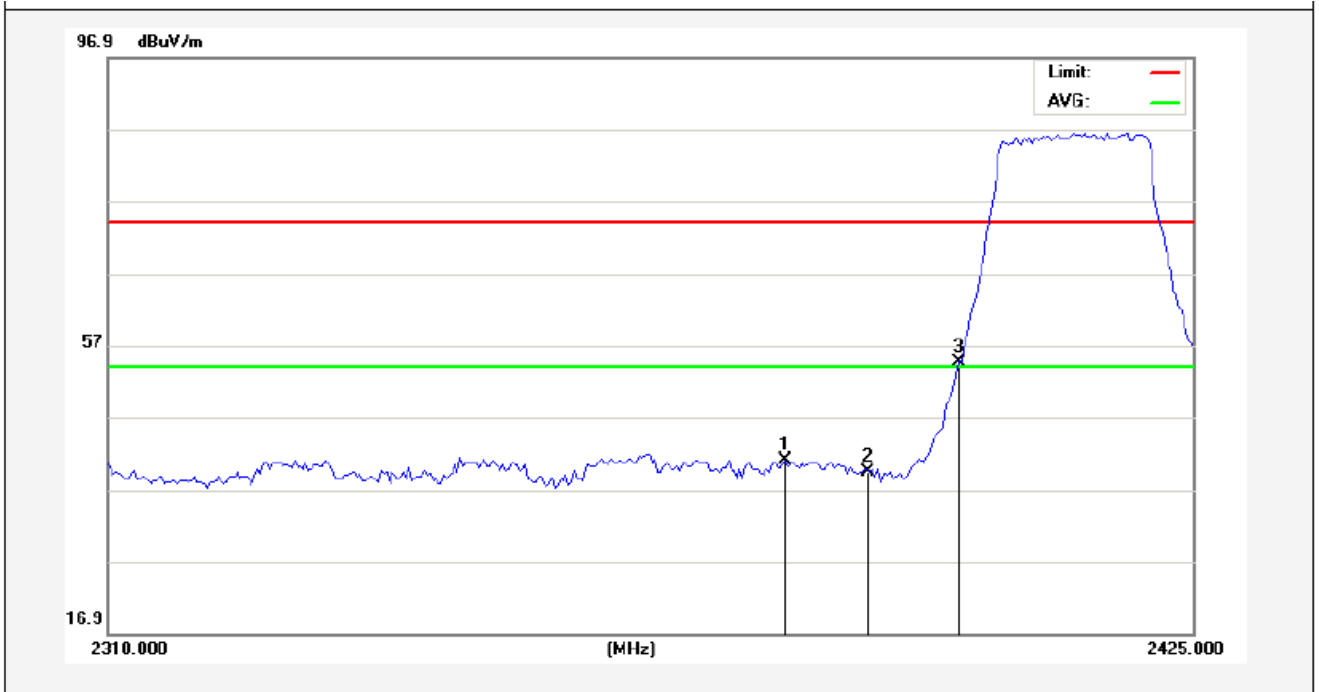

No.	Freq. (MHz)	Reading (dBuV/m)	Factor (dB/m)	Result (dBuV/m)	Limit (dBuV/)	Over Limit (dB)	Detector	Height (cm)	degree (deg)	Remark
1	2381.300	43.59	-2.53	41.06	74.00	-32.94	peak			
2	2390.000	41.85	-2.51	39.34	74.00	-34.66	peak			
3	2400.000	57.15	-2.49	54.66	74.00	-19.34	peak			

Anbotek

Vertical-AV:

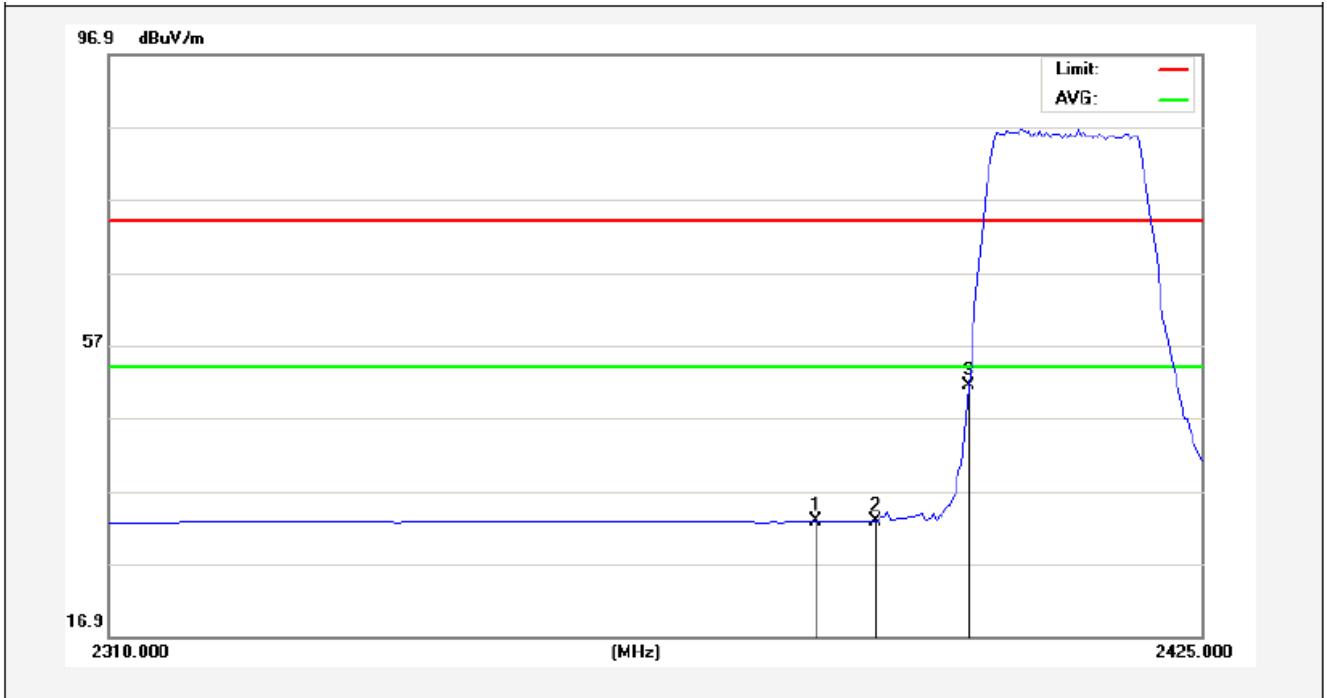

No.	Freq. (MHz)	Reading (dBuV/m)	Factor (dB/m)	Result (dBuV/m)	Limit (dBuV/)	Over Limit (dB)	Detector	Height (cm)	degree (deg)	Remark
1	2383.887	35.35	-2.53	32.82	54.00	-21.18	AVG			
2	2390.000	35.41	-2.51	32.90	54.00	-21.10	AVG			
3	2400.000	53.95	-2.49	51.46	54.00	-2.54	AVG			

Anbotek

Test Mode: 802.11n (HT20)

2462MHz

Horizontal-PEAK:

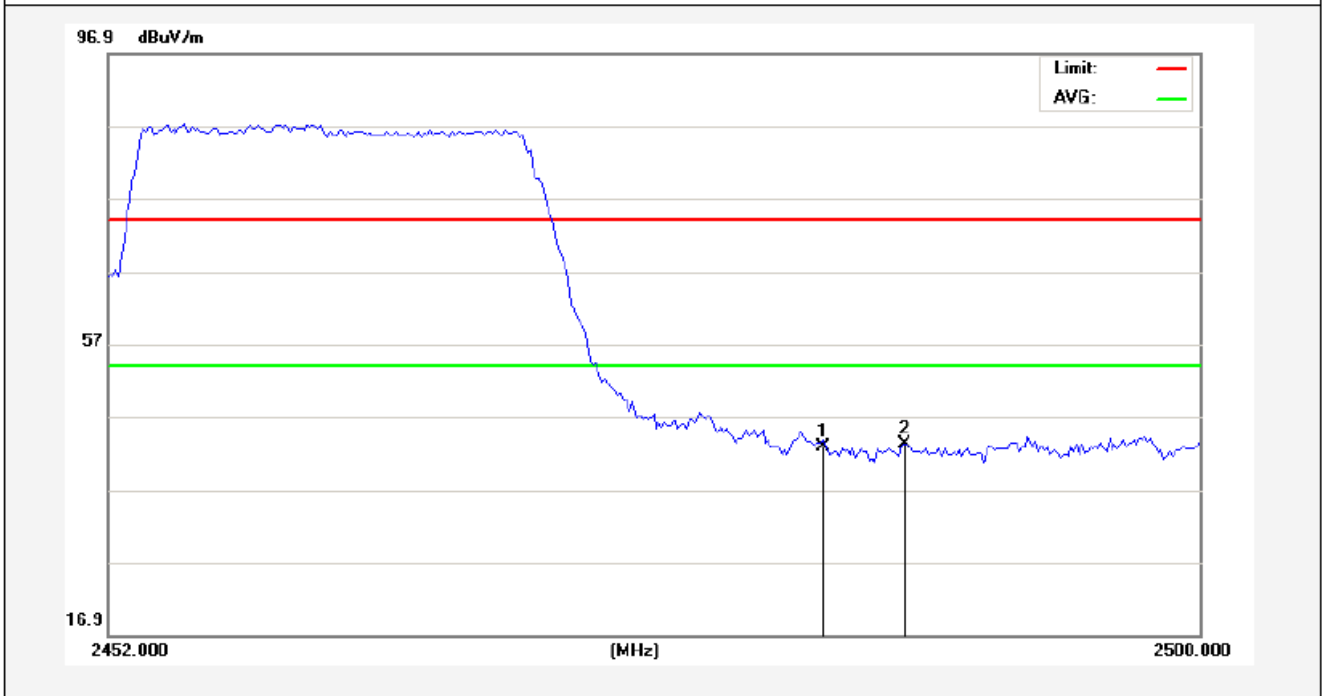

No.	Freq. (MHz)	Reading (dBuV/m)	Factor (dB/m)	Result (dBuV/m)	Limit (dBuV/)	Over Limit (dB)	Detector	Height (cm)	degree (deg)	Remark
1	2483.500	45.04	-2.31	42.73	74.00	-31.27	peak			
2	2487.040	45.47	-2.30	43.17	74.00	-30.83	peak			

Anbotek

Horizontal-AV:

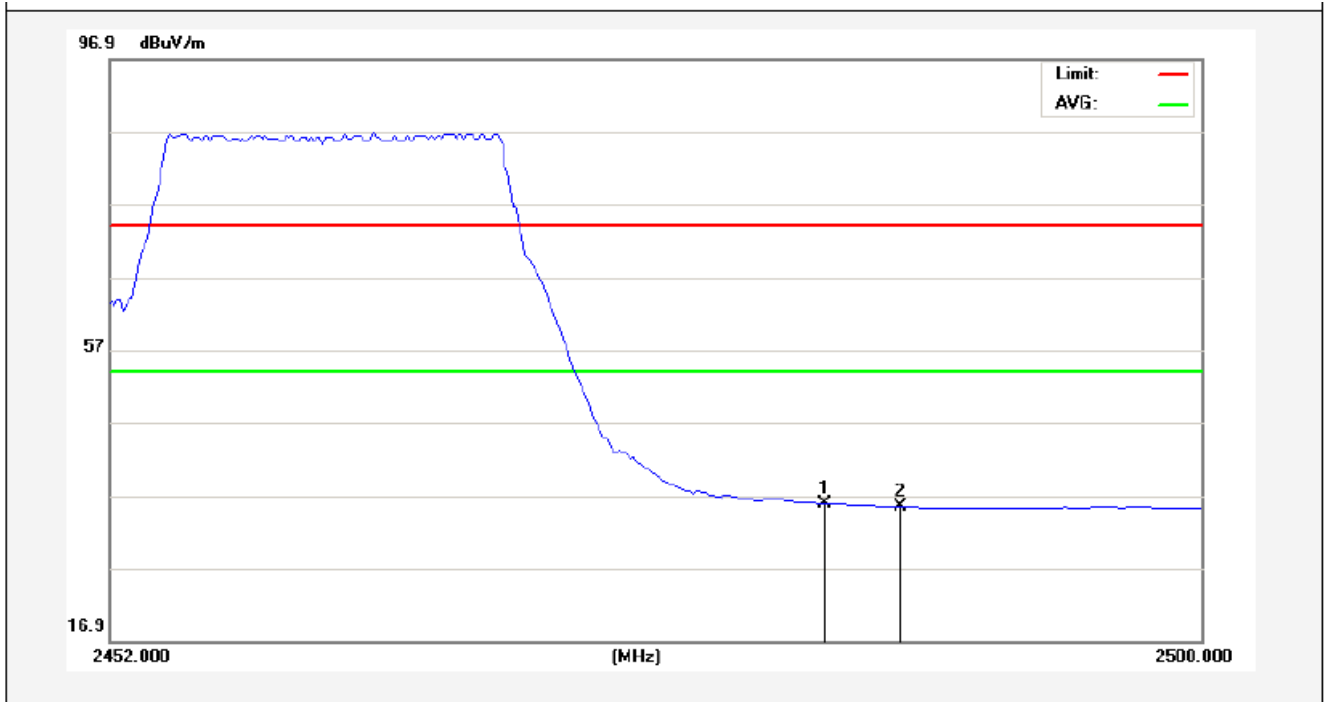

No.	Freq. (MHz)	Reading (dBuV/m)	Factor (dB/m)	Result (dBuV/m)	Limit (dBuV/)	Over Limit (dB)	Detector	Height (cm)	degree (deg)	Remark
1	2483.500	38.13	-2.31	35.82	54.00	-18.18	AVG			
2	2486.800	37.69	-2.30	35.39	54.00	-18.61	AVG			

Anbotek

Test Mode: 802.11n (HT20)

2462MHz

Vertical-PEAK:

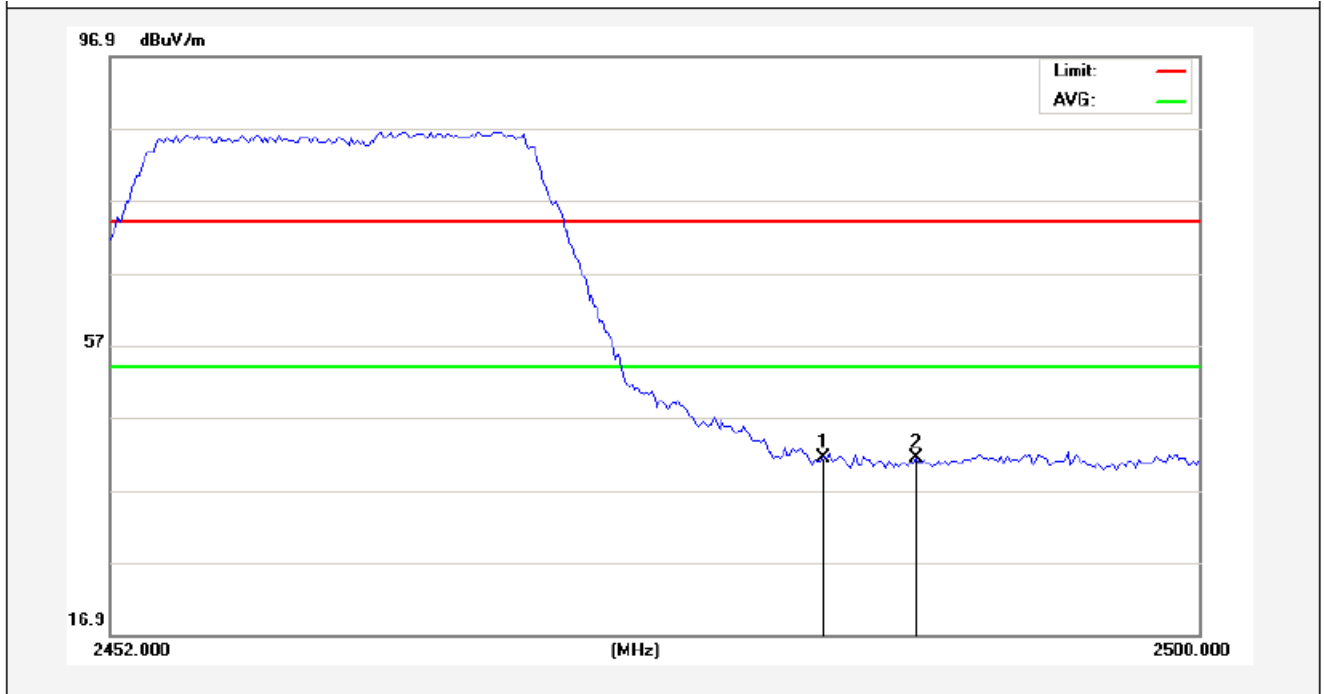

No.	Freq. (MHz)	Reading (dBuV/m)	Factor (dB/m)	Result (dBuV/m)	Limit (dBuV/)	Over Limit (dB)	Detector	Height (cm)	degree (deg)	Remark
1	2483.500	43.73	-2.31	41.42	74.00	-32.58	peak			
2	2487.520	43.61	-2.30	41.31	74.00	-32.69	peak			

Anbotek

Vertical-AV:

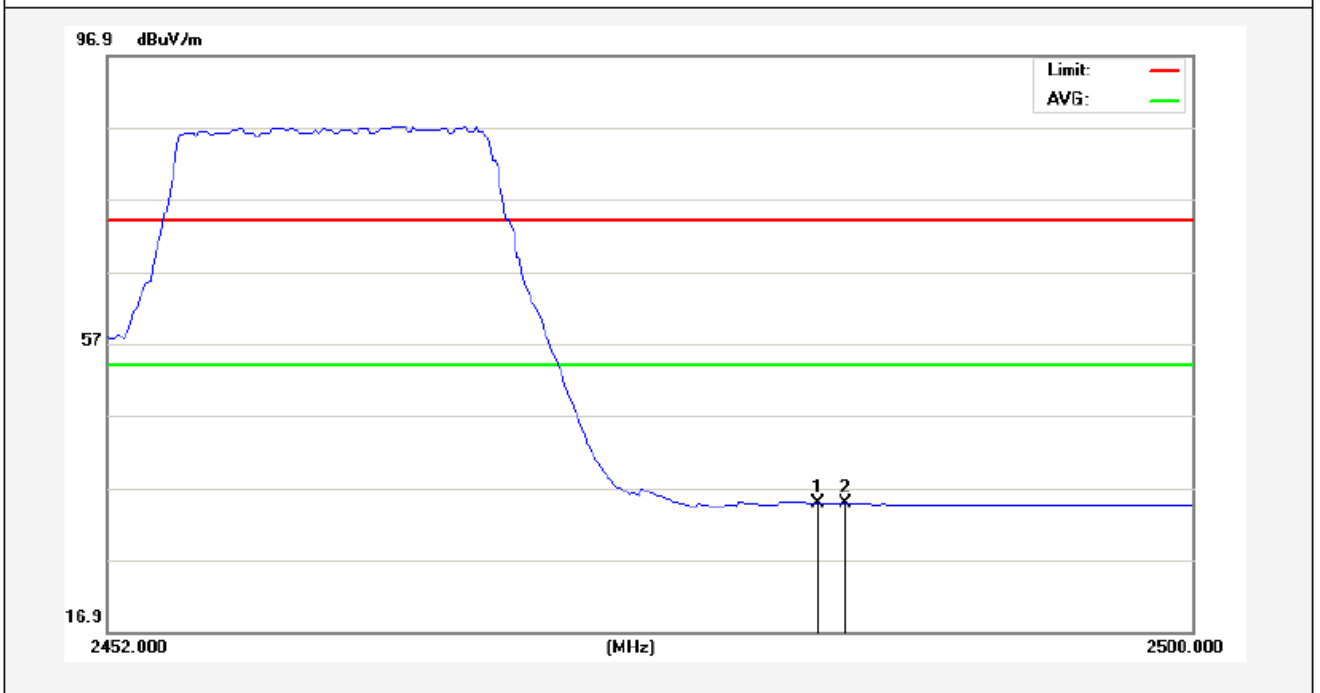

No.	Freq. (MHz)	Reading (dBuV/m)	Factor (dB/m)	Result (dBuV/m)	Limit (dBuV/)	Over Limit (dB)	Detector	Height (cm)	degree (deg)	Remark
1	2483.500	37.14	-2.31	34.83	54.00	-19.17	AVG			
2	2484.520	37.08	-2.30	34.78	54.00	-19.22	AVG			

Anbotek

Test Mode: 802.11n (HT40)

2422MHz

Horizontal-PEAK:

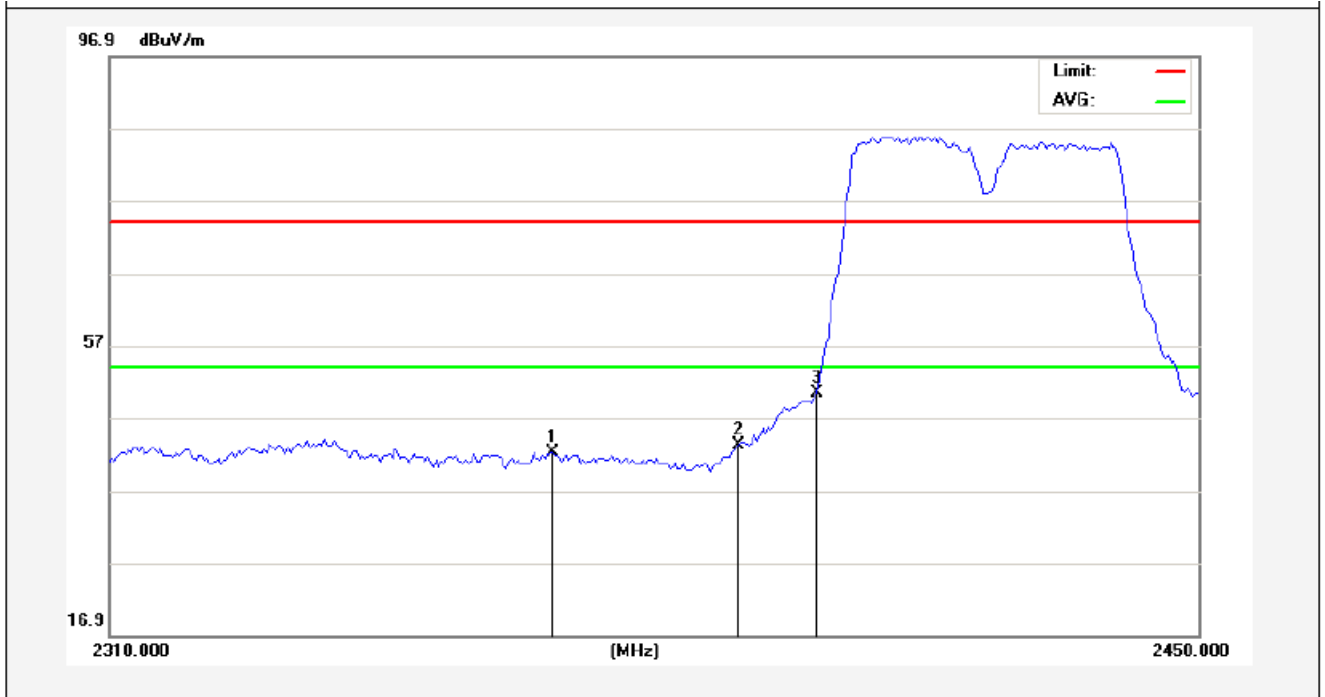

No.	Freq. (MHz)	Reading (dBuV/m)	Factor (dB/m)	Result (dBuV/m)	Limit (dBuV/)	Over Limit (dB)	Detector	Height (cm)	degree (deg)	Remark
1	2366.350	44.81	-2.57	42.24	74.00	-31.76	peak			
2	2390.000	45.77	-2.51	43.26	74.00	-30.74	peak			
3	2400.000	52.93	-2.49	50.44	74.00	-23.56	peak			

Anbotek

Horizontal-AV:

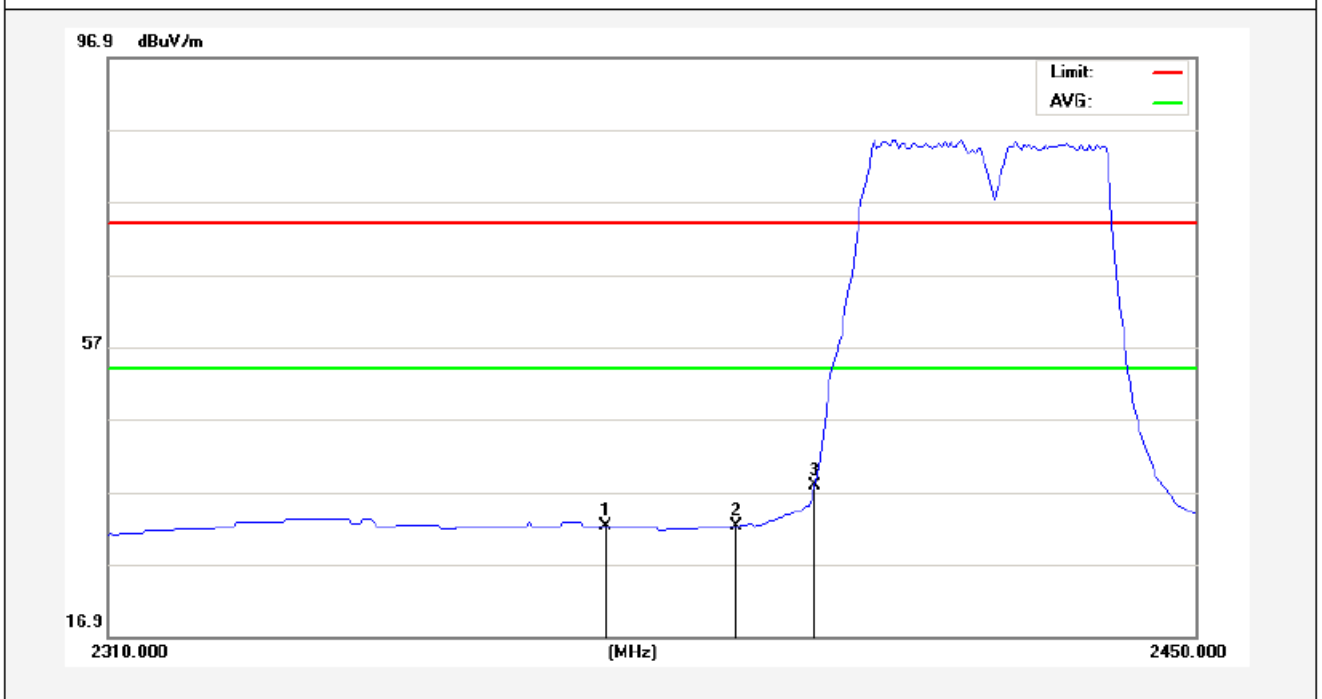

No.	Freq. (MHz)	Reading (dBuV/m)	Factor (dB/m)	Result (dBuV/m)	Limit (dBuV/)	Over Limit (dB)	Detector	Height (cm)	degree (deg)	Remark
1	2373.350	34.77	-2.55	32.22	54.00	-21.78	AVG			
2	2390.000	34.76	-2.51	32.25	54.00	-21.75	AVG			
3	2400.000	40.36	-2.49	37.87	54.00	-16.13	AVG			

Anbotek

Test Mode: 802.11n (HT40)

2422MHz

Vertical-PEAK:

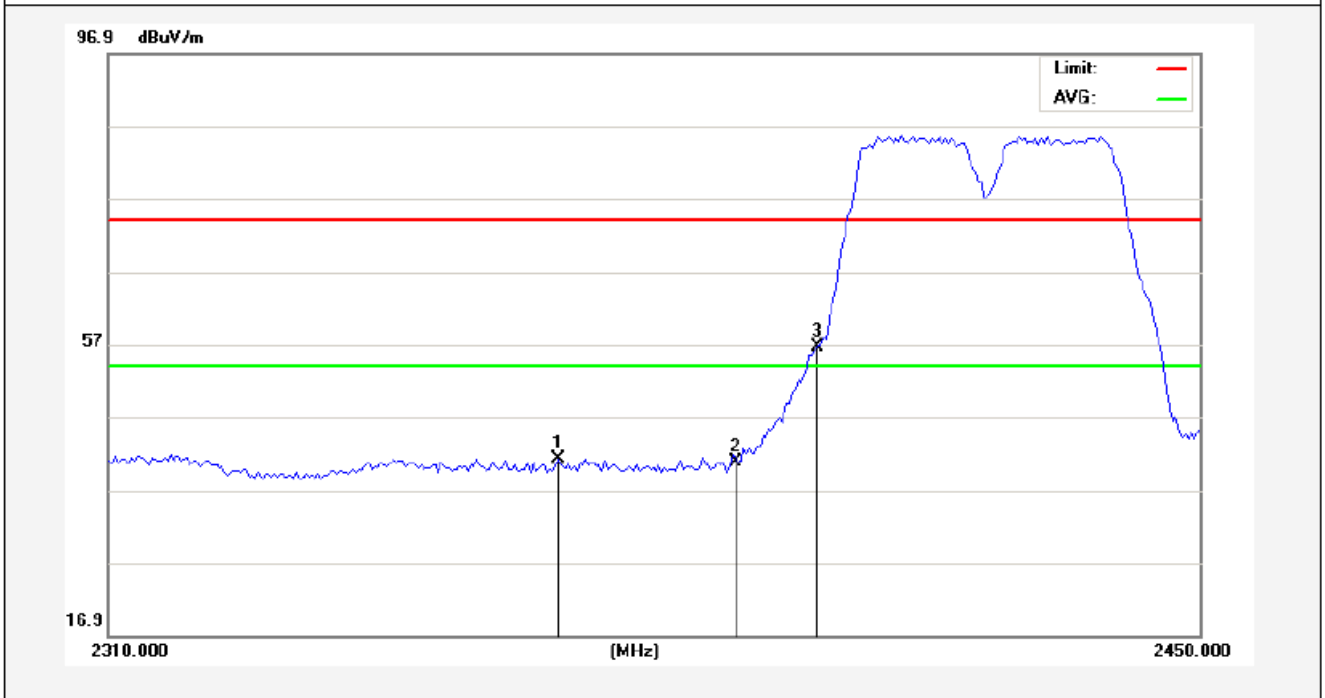

No.	Freq. (MHz)	Reading (dBuV/m)	Factor (dB/m)	Result (dBuV/m)	Limit (dBuV/)	Over Limit (dB)	Detector	Height (cm)	degree (deg)	Remark
1	2367.050	43.83	-2.57	41.26	74.00	-32.74	peak			
2	2390.000	43.36	-2.51	40.85	74.00	-33.15	peak			
3	2400.000	59.16	-2.49	56.67	74.00	-17.33	peak			

Anbotek

Vertical-AV:

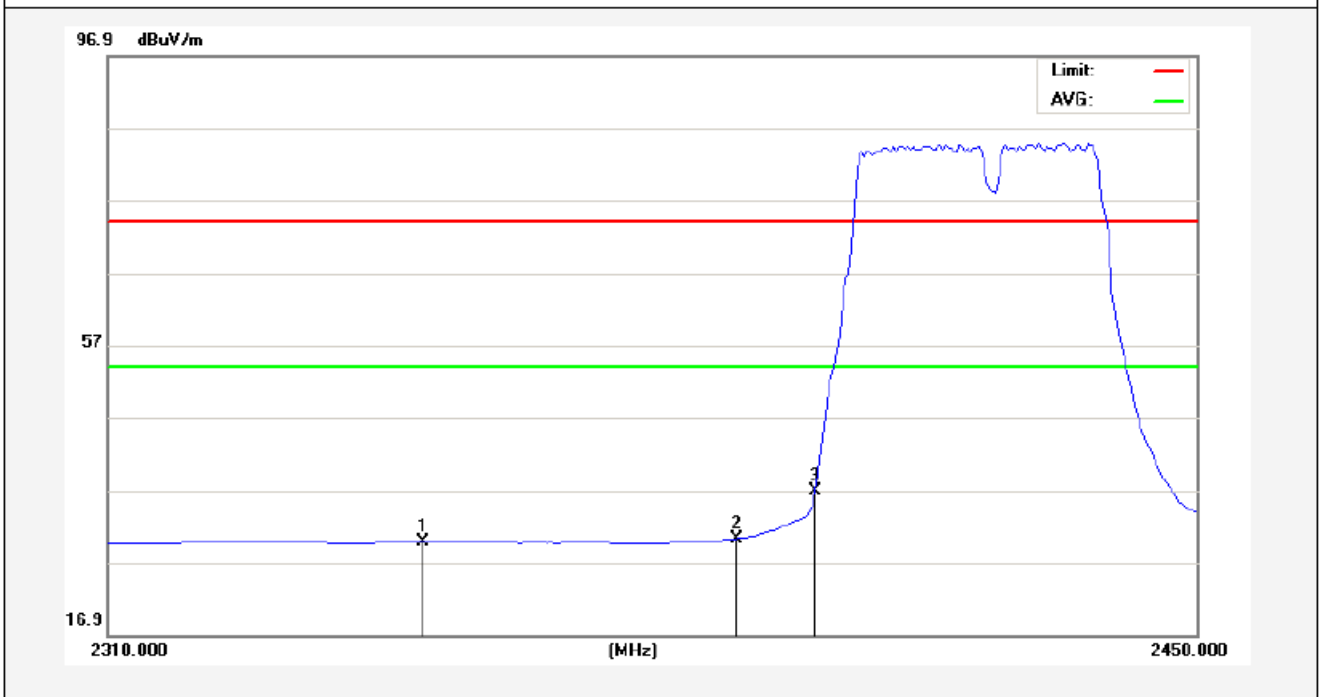

No.	Freq. (MHz)	Reading (dBuV/m)	Factor (dB/m)	Result (dBuV/m)	Limit (dBuV/)	Over Limit (dB)	Detector	Height (cm)	degree (deg)	Remark
1	2349.900	32.43	-2.60	29.83	54.00	-24.17	AVG			
2	2390.000	32.75	-2.51	30.24	54.00	-23.76	AVG			
3	2400.000	39.34	-2.49	36.85	54.00	-17.15	AVG			

Anbotek

Test Mode: 802.11n (HT40)

2452MHz

Horizontal-PEAK:

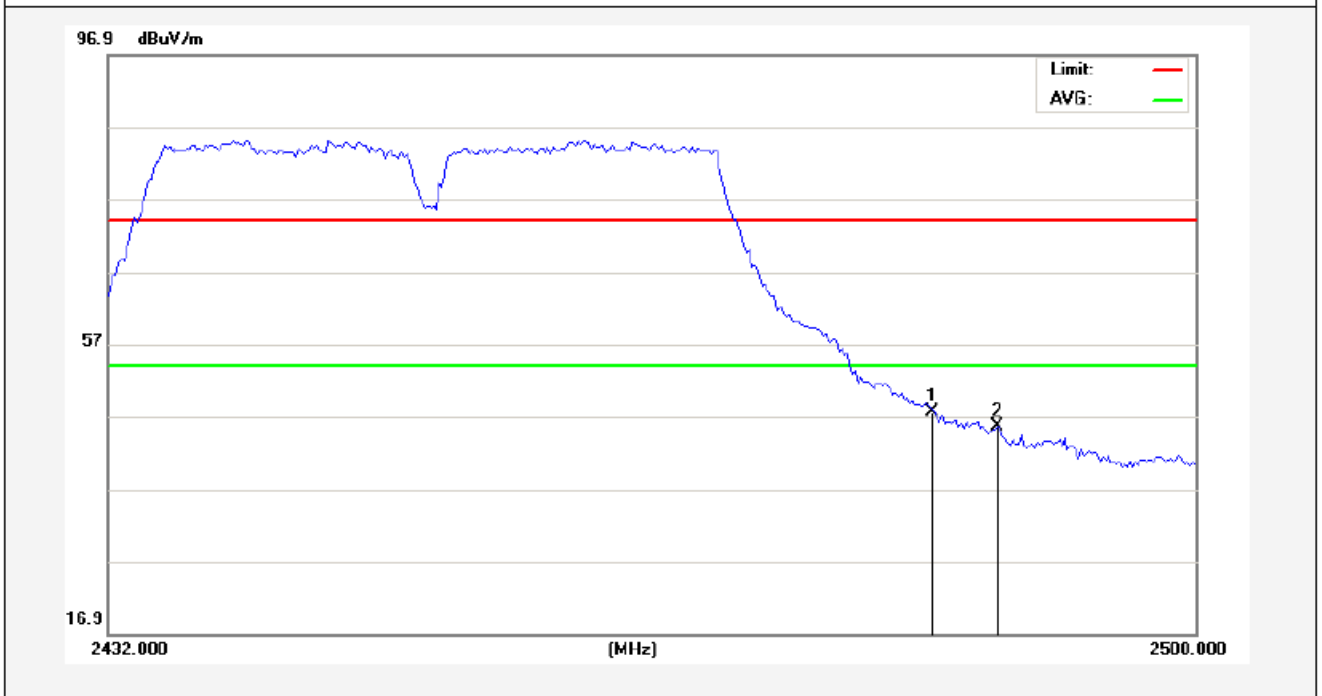

No.	Freq. (MHz)	Reading (dBuV/m)	Factor (dB/m)	Result (dBuV/m)	Limit (dBuV/)	Over Limit (dB)	Detector	Height (cm)	degree (deg)	Remark
1	2483.500	49.94	-2.31	47.63	74.00	-26.37	peak			
2	2487.590	47.94	-2.30	45.64	74.00	-28.36	peak			

Anbotek

Horizontal-AV:

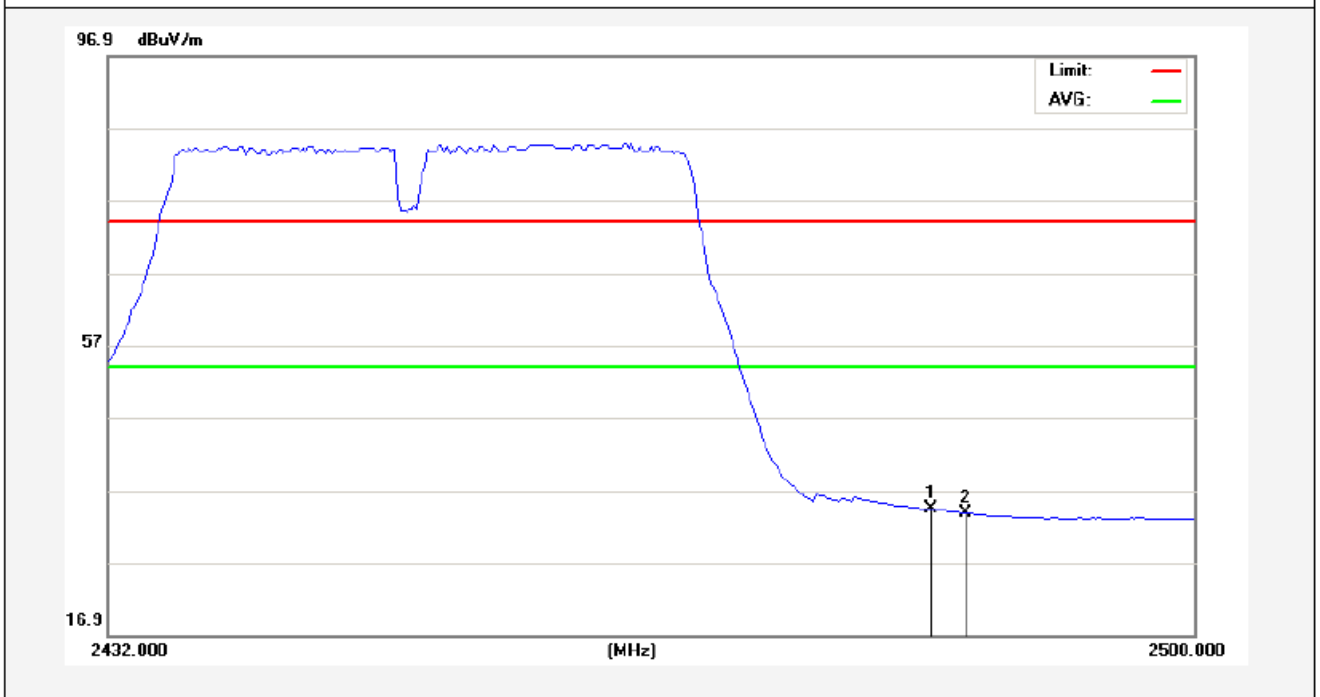

No.	Freq. (MHz)	Reading (dBuV/m)	Factor (dB/m)	Result (dBuV/m)	Limit (dBuV/)	Over Limit (dB)	Detector	Height (cm)	degree (deg)	Remark
1	2483.500	36.64	-2.31	34.33	54.00	-19.67	AVG			
2	2485.720	36.13	-2.30	33.83	54.00	-20.17	AVG			

Anbotek

Test Mode: 802.11n (HT40)

2452MHz

Vertical-PEAK:

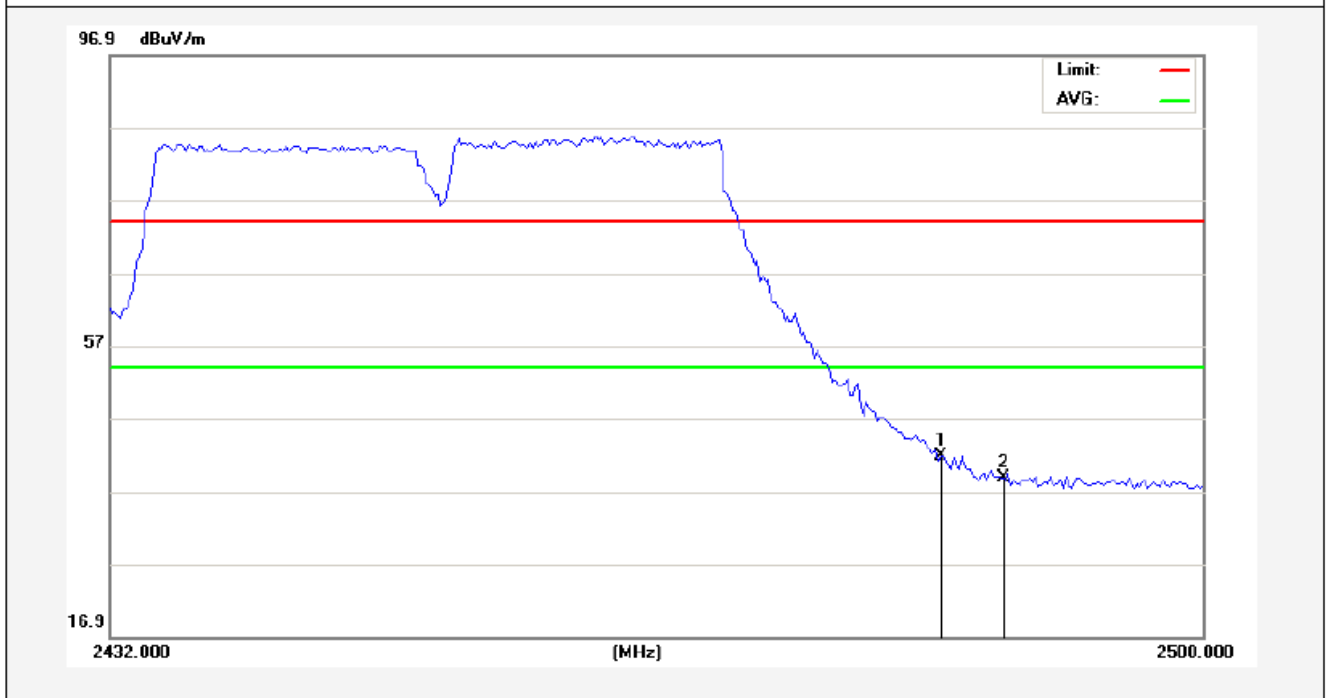

No.	Freq. (MHz)	Reading (dBuV/m)	Factor (dB/m)	Result (dBuV/m)	Limit (dBuV/)	Over Limit (dB)	Detector	Height (cm)	degree (deg)	Remark
1	2483.500	44.08	-2.31	41.77	74.00	-32.23	peak			
2	2487.590	41.15	-2.30	38.85	74.00	-35.15	peak			

Anbotek

Vertical-AV:

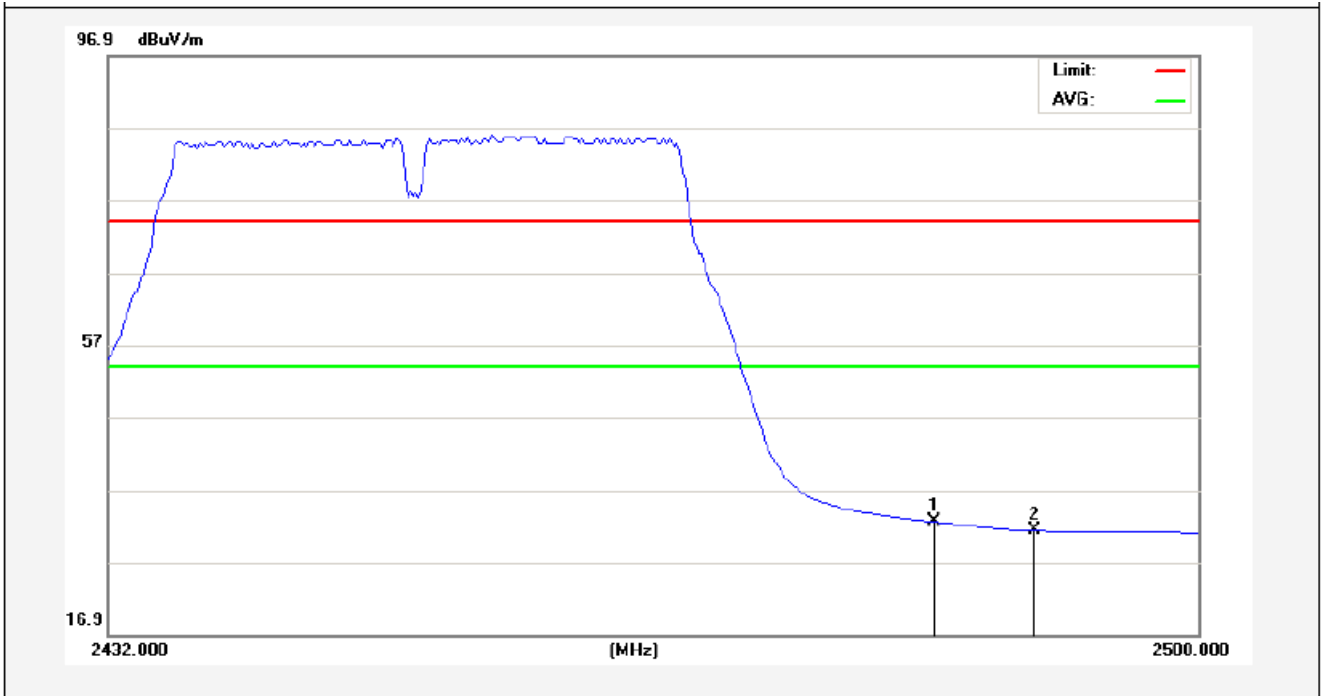

No.	Freq. (MHz)	Reading (dBuV/m)	Factor (dB/m)	Result (dBuV/m)	Limit (dBuV/)	Over Limit (dB)	Detector	Height (cm)	degree (deg)	Remark
1	2483.500	34.85	-2.31	32.54	54.00	-21.46	AVG			
2	2489.800	33.66	-2.29	31.37	54.00	-22.63	AVG			

Anbotek

4.5. Peak Power Spectral Density

a. Limit

1. For direct sequence systems, the peak power spectral density conducted from the intentional radiator to the antenna shall not be greater than 8dBm in any 3kHz band during any time interval of continuous transmission.
2. The direct sequence operating of the hybrid system, with the frequency hopping operation turned off, shall comply with the power density requirements of paragraph (d) of this section.

b. Test Procedure

1. Place the EUT on the table and set it in transmitting mode. Remove the antenna from the EUT and then connect a low loss RF cable from the antenna port to the spectrum analyzer.
2. Set the spectrum analyzer as RBW = 10kHz, VBW = 30kHz, Span = 1.5xDTS BW
3. Record the max. reading.
4. Repeat the above procedure until the measurements for all frequencies are completed.

c. Test Equipment

Same as the equipment listed in 4.2.

d. Test Setup

See 4.1

e. Test Results

Pass

f. Test Data

Please refer to the following data.

g. Test Plot See the following pages

ANT A

Test mode: IEEE 802.11b

Channel	Frequency (MHz)	PPSD (dBm/3KHz)	∑PPSD (dBm/3KHz)	Limit (dBm)	Result
Low	2412	-0.023	-	8.00	Pass
Mid	2437	0.152	-		Pass
High	2462	-0.226	-		Pass

Test mode: IEEE 802.11g

Channel	Frequency (MHz)	PPSD (dBm)	∑PPSD (dBm)	Limit (dBm)	Result
Low	2412	-6.377	-	8.00	Pass
Mid	2437	-6.575	-		Pass
High	2462	-7.099	-		Pass

Test mode: IEEE 802.11n (HT20)

Channel	Frequency (MHz)	PPSD (dBm/3KHz)	∑PPSD (dBm/3KHz)	Limit (dBm)	Result
Low	2412	-5.604	-	8.00	Pass
Mid	2437	-5.790	-		Pass
High	2462	-5.771	-		Pass

Test mode: IEEE 802.11n (HT40)

Channel	Frequency (MHz)	PPSD (dBm/3KHz)	∑PPSD (dBm/3KHz)	Limit (dBm)	Result
Low	2422	-10.306	-	8.00	Pass
Mid	2437	-9.370	-		Pass
High	2452	-9.260	-		Pass

ANT B

Test mode: IEEE 802.11b

Channel	Frequency (MHz)	PPSD (dBm/3KHz)	Σ PPSD (dBm/3KHz)	Limit (dBm)	Result
Low	2412	-1.020	-	8.00	Pass
Mid	2437	-0.413	-		Pass
High	2462	-0.476	-		Pass

Test mode: IEEE 802.11g

Channel	Frequency (MHz)	PPSD (dBm)	Σ PPSD (dBm)	Limit (dBm)	Result
Low	2412	-7.246	-	8.00	Pass
Mid	2437	-7.057	-		Pass
High	2462	-7.250	-		Pass

Test mode: IEEE 802.11n (HT20)

Channel	Frequency (MHz)	PPSD (dBm/3KHz)	Σ PPSD (dBm/3KHz)	Limit (dBm)	Result
Low	2412	-5.950	-	8.00	Pass
Mid	2437	-5.939	-		Pass
High	2462	-6.344	-		Pass

Test mode: IEEE 802.11n (HT40)

Channel	Frequency (MHz)	PPSD (dBm/3KHz)	Σ PPSD (dBm/3KHz)	Limit (dBm)	Result
Low	2422	-9.470	-	8.00	Pass
Mid	2437	-9.062	-		Pass
High	2452	-9.434	-		Pass

Channel	Channel Frequency (MHz)	ANT A PSD (dBm)	ANT B PSD (dBm)	Data Rate (Mbps)	MIMO PSD (dBm)	Limit (dBm)
802.11n (20M MIMO) mode						
Low	2412	-5.604	-5.950	MCS0	-2.765	8
Middle	2437	-5.790	-5.939	MCS0	-2.848	8
High	2462	-5.771	-6.344	MCS0	-3.036	8
802.11n (40M MIMO) mode						
Low	2422	-10.306	-9.470	MCS0	-6.861	8
Middle	2437	-9.370	-9.062	MCS0	-6.198	8
High	2452	-9.260	-9.434	MCS0	-6.326	8

ANT A

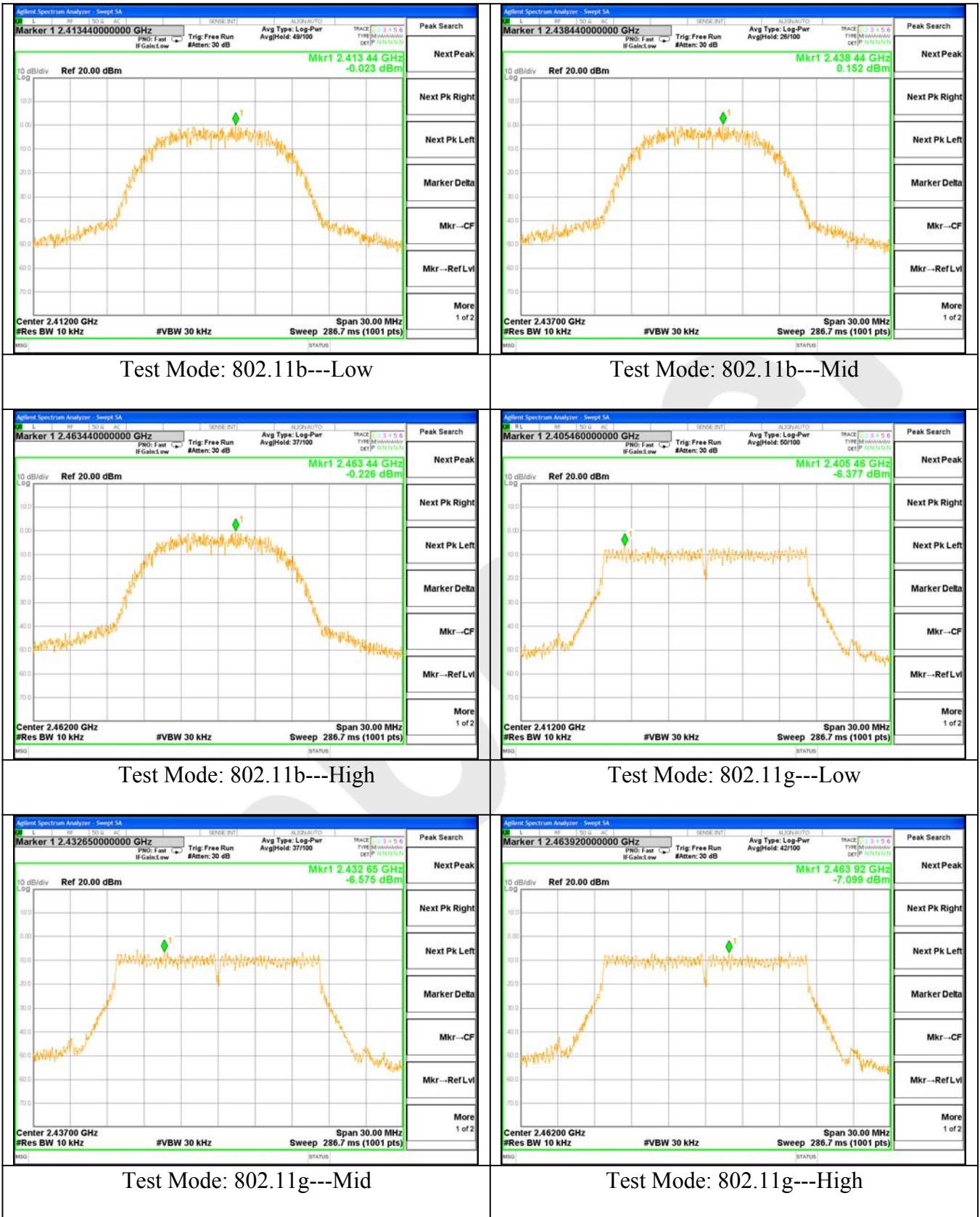

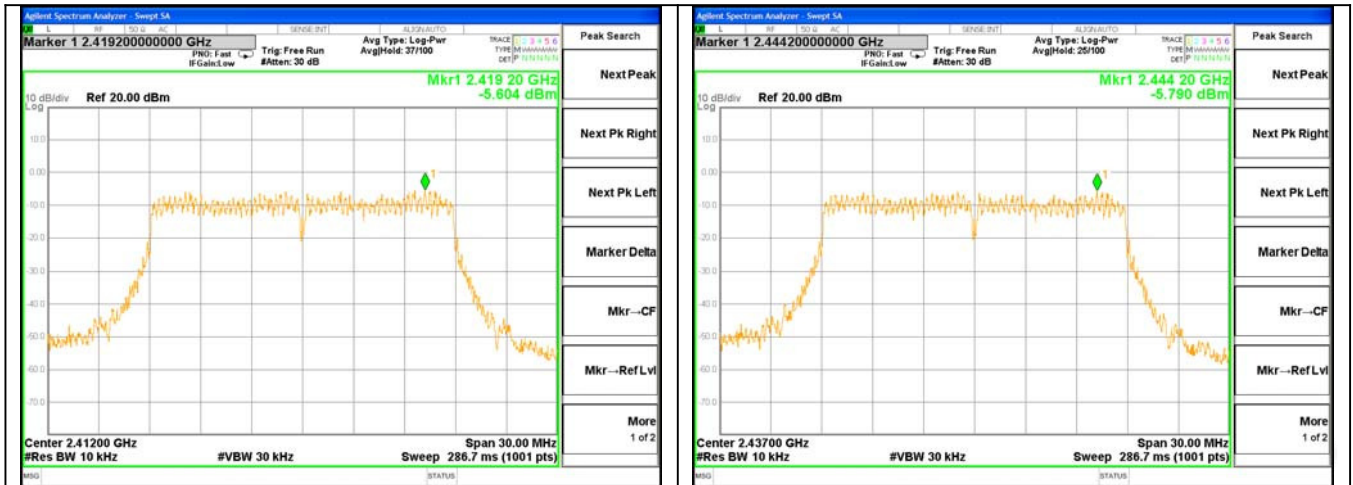

Test Mode: 802.11n20---Low

Test Mode: 802.11n20---Mid

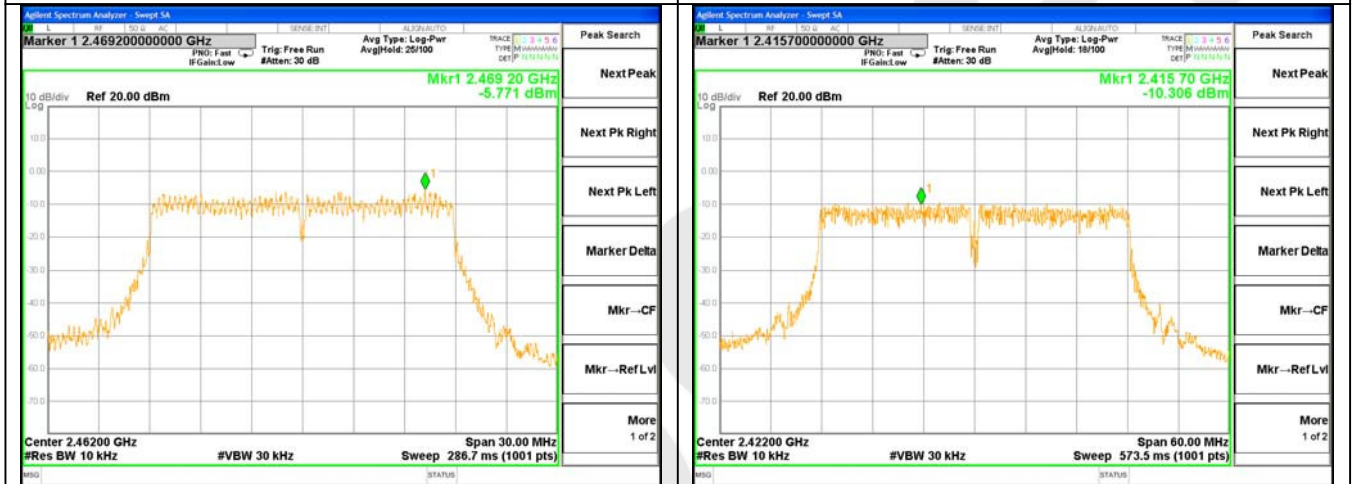

Test Mode: 802.11n20---High

Test Mode: 802.11n40---Low

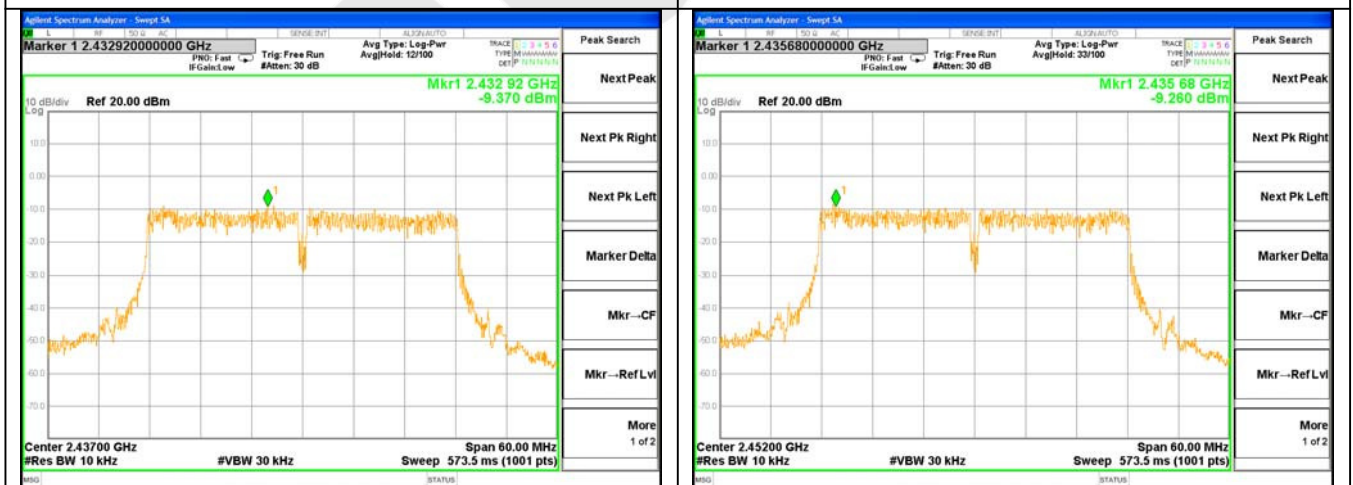

Test Mode: 802.11n40---Mid

Test Mode: 802.11n40---High

ANT B

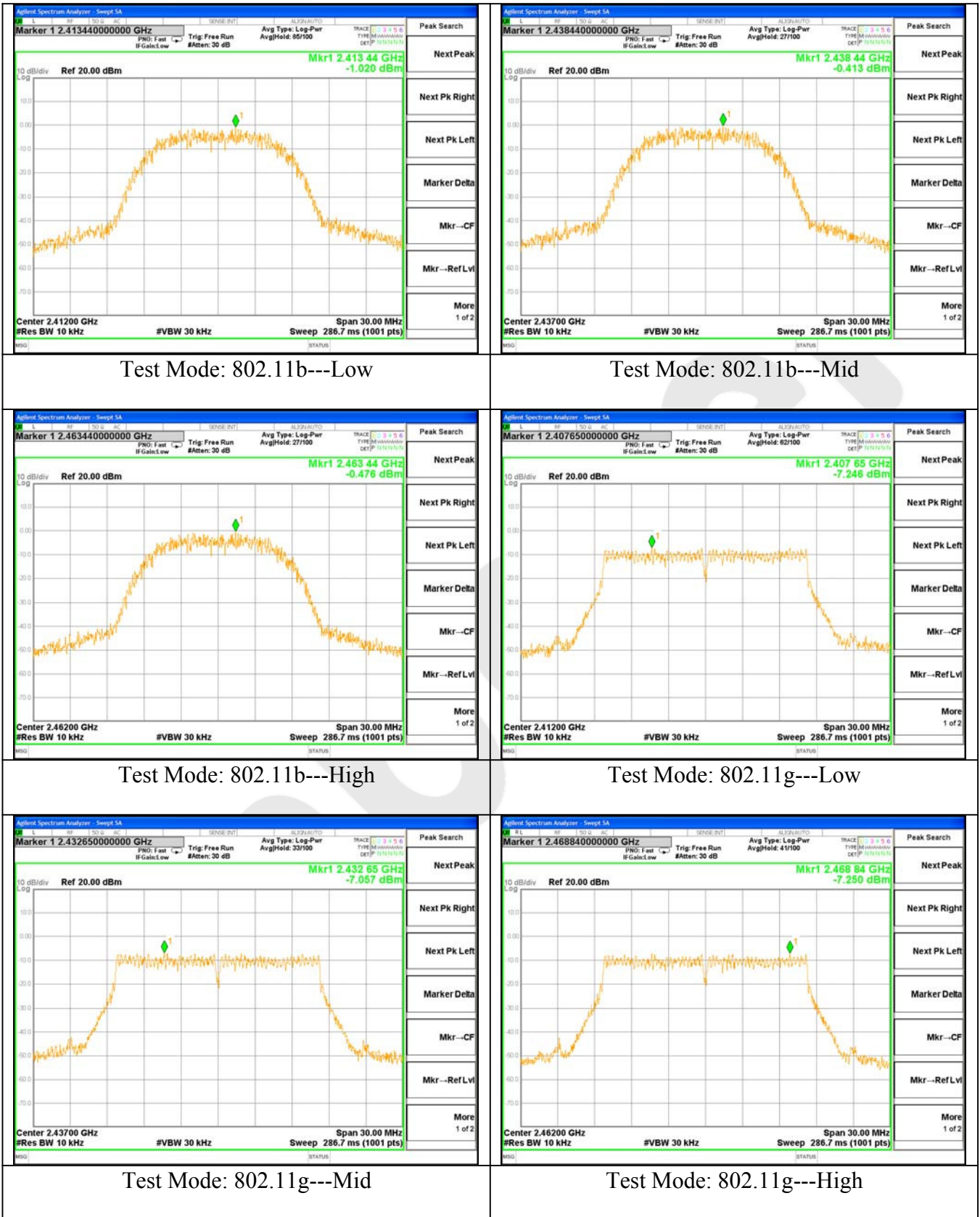

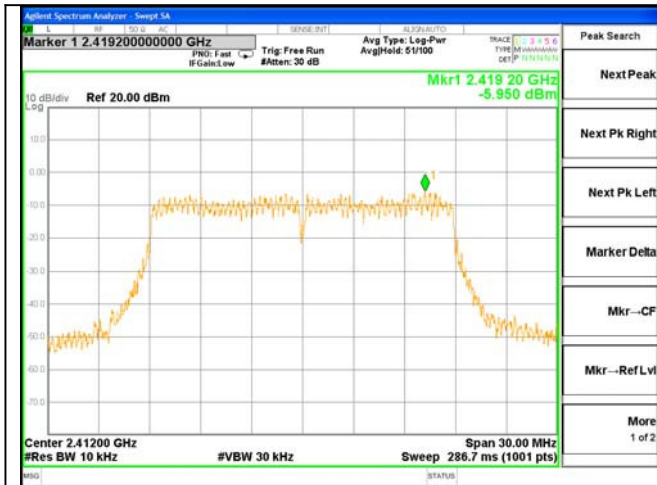

Test Mode: 802.11n20---Low

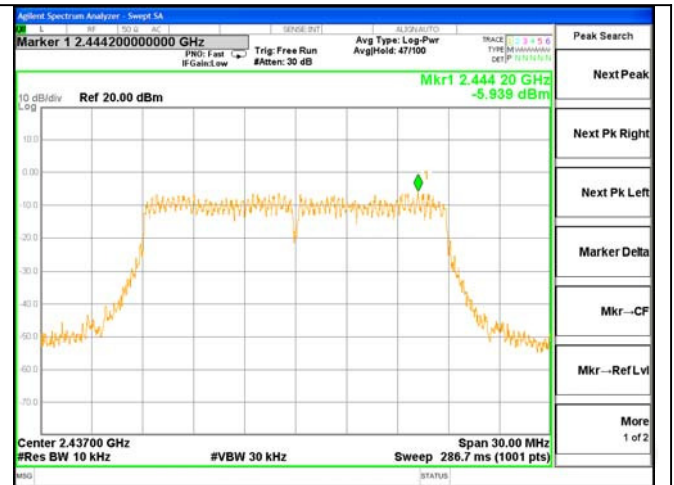

Test Mode: 802.11n20---Mid

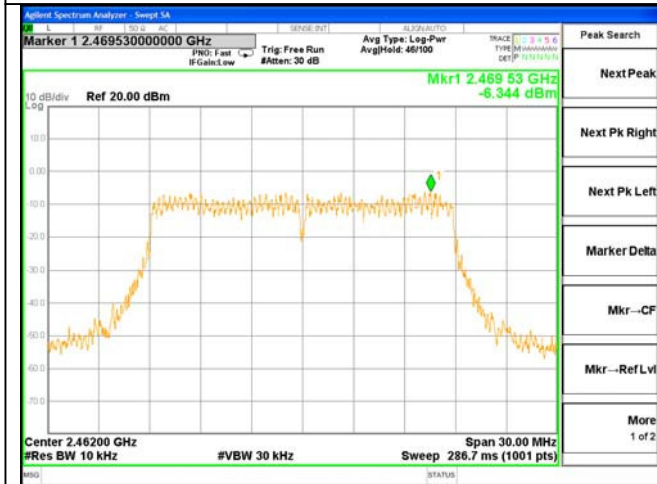

Test Mode: 802.11n20---High

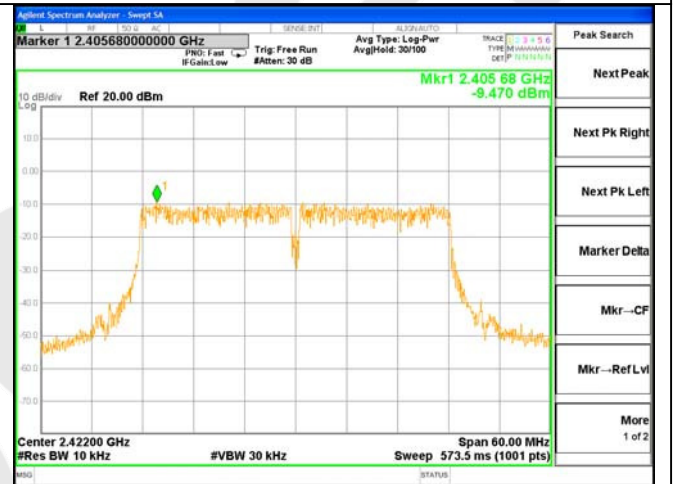

Test Mode: 802.11n40---Low

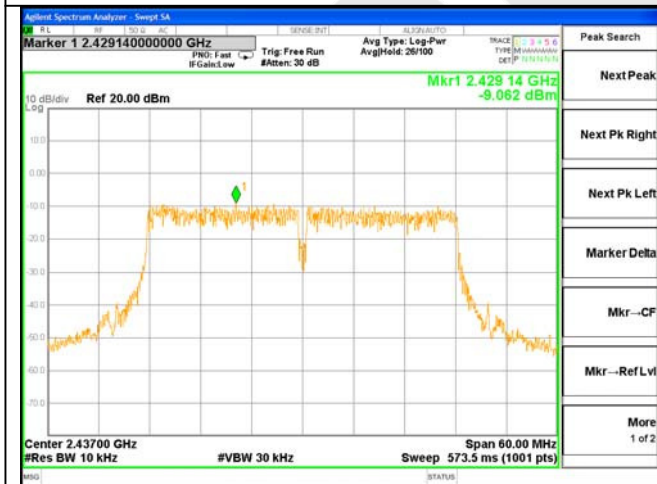

Test Mode: 802.11n40---Mid

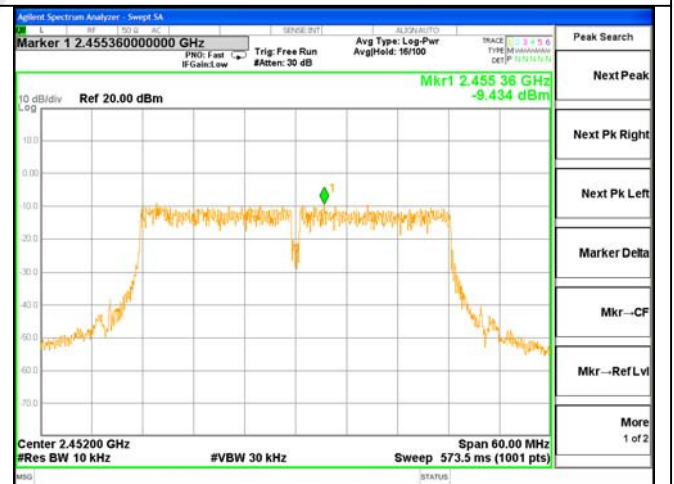

Test Mode: 802.11n40---High