



**Always Connected. Always Covered.**

# **Extender**

**DMEX1**

# **User Manual**

# Preface

As this is the full User Manual, a working knowledge of Z-Wave automation terminology and concepts will be assumed. If you are a beginner user, please visit [www.domeha.com](http://www.domeha.com) for instructions. This manual will provide in-depth technical information about the Extender, especially in re-gards to its compliance to the Z-Wave standard (such as compatible Com-mand Classes, Association Group capabilities, special features, and other information) that will help you maximize the utility of this product in your system.

# Table of Contents

Preface .....	2
Description & Features .....	4
Specifications.....	5
Physical Characteristics .....	6
Inclusion & Exclusion.....	7
Physical Installation .....	9
LED Behavior .....	10
Button Behavior .....	11
Compatible Command Classes.....	12
“Configuration” Command Class Parameters .....	13
Troubleshooting .....	14
Warranty & Support.....	15

# Specifications

## Technical Specifications

<b>Radio protocol</b>	<b>Z-Wave(500 series)</b>
<b>Power supply</b>	<b>110/240 V AC</b>
<b>Working current</b>	<b>48 mA (when nightlight is brightest)</b>
<b>Operating temperature</b>	<b>0 - 40 °C</b>
<b>Radio frequency</b>	<b>908.4Mhz or 916Mhz</b>
<b>Range</b>	<b>Up to 260' depending on environment</b>
<b>Dimensions (L x W x H)</b>	<b>Excluding Plug:</b>

Table 1 - Technical Specifications

## Package Contents:

Dome extender x1 Mounting  
hardware/suction cup

The DOME Extender, a device that amplifies Z-Wave signals and increases the reach of your controller, ensuring your devices stay connected. The extender consists of an LED light which serves dual purposes depending upon the requirement, one where it works as an indicator or regular on/off light and other where it works as a night light. The extender also includes a suction cup which enables mounting onto any smooth surface.

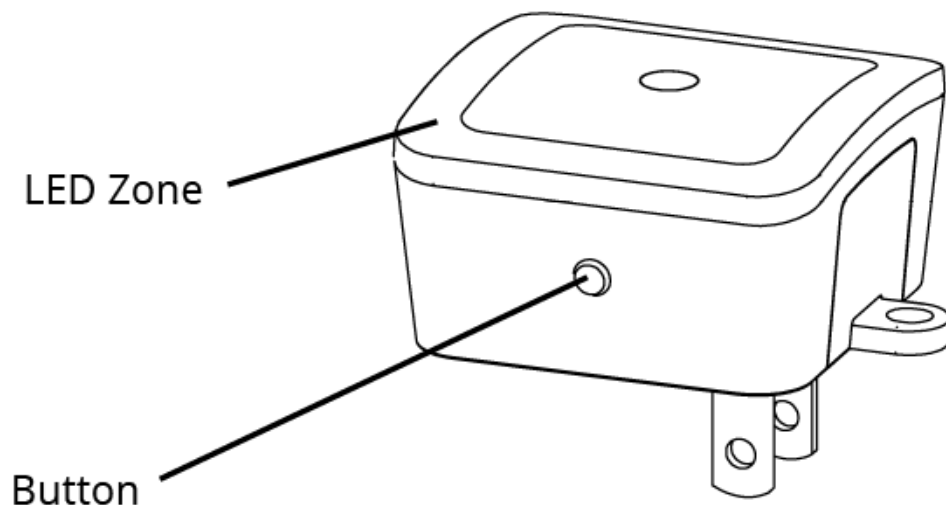

# Inclusion & Exclusion

## **Inclusion (Add to System)**

1. For proper inclusion, bring the Extender to the final location where it will be used\*.
2. Follow the instructions for your Z-Wave controller to enter inclusion mode.
3. Supply power to the Extender to begin inclusion mode. If the Extender is already powered on, press the button 3 times quickly.
4. The device will enter inclusion mode for two minutes and the LED Ring will blink quickly (1 times/sec) until it's included in a system.

Upon successful inclusion, the LED Ring will blink slowly three times and then stay on permanently.

## **Exclusion (Remove from System)**

Follow the instructions for your Z-Wave Certified Controller to enter exclusion mode. When prompted by the controller:

1. Make sure the Extender is powered on.
2. Press the Button quickly 3 times in a row.

Upon successful inclusion, the LED Ring blink slowly three times and then blink once every half second until it is included in a system.

\*For non Z-Wave Plus networks, please consult the owner's manual for your primary controller to determine the best method/location for adding the Extender to your Z-Wave network. A Security Enabled Z-Wave Controller must be used in order to fully utilize the product

## Resetting the Extender

If needed, the Extender can be reset locally by following these steps. **Only do this if your Z-Wave controller is missing or otherwise unreachable.**

Beware that resetting your device will disconnect it from the system:

1. Make sure that your Extender is powered on.
2. Press the button 6 times quickly, then immediately press and hold for 10 seconds.

The Extender's memory will be erased to factory settings and the LED Ring will blink very quickly six times and then blink once every half second until it is included in a system.

# Physical Installation

The Extender can be plugged directly into a standard power outlet, or mounted on a wall or window with the included hardware and USB power supply. Include the Extender into your Z-Wave network and make sure it can communicate from the installation location before continuing further.

## Installation On the Power Outlet (Secured with Screw)

1. Unscrew the wall plate screw adjacent to the outlet the Extender will be plugged into.
2. Plug in the Extender, making sure the Screw Flange is directly over the wall plate's screw hole.
3. Secure the Extender in place by replacing the wall plate screw.

## Installation On the Power Outlet (Unsecured)

1. Plug in the Extender.

## Installation On a Wall or Window

1. Remove the Power Plug Insert from the Extender and replace it with the Wall Mount Insert.
2. Either secure the included screw into a wall with the dry wall anchor, leaving it 1/8" (3.5 mm) away from the wall. If securing to a window, mount the included suction cup on the desired location on the window.
3. Slide the Screw Head or the knob of the Suction Cup into the keyhole slot on the Extender.
4. Plug the micro USB cable into the Extender and power up the device by plugging it into the power outlet.



# LED Behavior

Behavior	This happens when...
Flash for Two Seconds	...the Extender is first powered on.
Blinks 1x Every Second	...the Extender is in inclusion mode. It will continue blinking and remain in inclusion mode for up to two minutes, until it is included in a system.
Stays on Consistently	...the Extender is included in a system.
Blinks 3 times in Two Seconds	...the Button is pressed 3 times quickly and the device is excluded from the system or sends a Node Info packet to the main controller. This also happens when the device is successfully included into the system.
Flash Once	...the LED is set to "Always On".
Flash Twice	...the LED is set to "Nightlight" mode.
Flash Three Times	...the Status LED is disabled.
Blinks Very Quickly 6 Times	...the device is reset to factory settings.

Table 2 - LED Blinking Behavior

# Button Behavior

Action	Condition	Result
<b>Push Button Once</b>	Always	The first time the Button is pushed, the Night-light LEDs will display the current LED Mode (see chart below.) Subsequent presses within FIVE seconds will toggle between LED modes.
		Flash once      LED Always On
		Flash twice      Only on When Dark
		Flash three times      LED is Off
<b>Press and Hold</b>	Always	Device ramps through the available brightness settings of the nightlight, from the current value down to the lowest brightness, then back up to the highest brightness. The user should release the button at the desired brightness level.
<b>Push Button 3 Times</b>	Extender Already Included in System	Device sends node info to Group 1
	Extender Already Included, and Controller is in Exclusion Mode	Device is excluded from the system and removes the Home ID from its memory
	Extender Not Yet Included in System, and Controller is in Inclusion Mode	Device enters inclusion mode and includes into whichever network is also in inclusion mode
<b>Press the Button 6 times then hold for 10 Sec</b>	Extender Already Included in System	Device will be reset to factory settings, and a DEVICE_RESET_LOCALLY command will be sent to Group 1

# Compatible Command Classes

Command Class - [Security Level]	Notes
Device Reset Locally V1 (5A) - [S0/S2]	-
Powerlevel V1 (73) - [S0/S2]	-
Security 0 (98) - [None]	-
Security 2 (9F) - [None]	-
Supervision V1 (6C) - [None]	-
Transport Service V2 (55)	-
Association (85) - [S0/S2]	<b>Group 1</b> Group 1 is the "Lifeline" group, which can hold five devices.
Association Group Information V1 (59) - [S0/S2]	-
Z-Wave Plus Info V2 (5E)	<b>Returned Value: 01 06 00 0C 06 0C 06</b> Z-Wave Plus Version: 01 Role Type: x ( <i>Always On Slave</i> ) Node Type: 00 ( <i>Z-Wave Plus Node</i> ) Installer Icon Type: 1B 00 ( <i>Repeater</i> ) User Icon Type: 1B 00 ( <i>Repeater</i> )
Version V2 (86) - [S0/S2]	<b>Returned Value: 03 04 21 01 11 1E 00</b> Z-Wave Library Type: 03 ( <i>Enhanced Slave</i> ) Protocol Version: 04 21 Protocol Sub-Version: 01 11 Application Version: 1E Application Sub-Version: 00
Manufacturer Specific V2 (72) - [S0/S2]	<b>Returned Value: 02 1F 00 03 01 08</b> Manufacturer ID: 02 1F Product Type: 00 03 Product ID: 01 08

# “Configuration” Command Class Parameters

Configuration parameters are sent using a standard syntax to ensure interoperability between all manufacturers’ products. All values are represented using the hexadecimal number system.

Typical syntax is as shown below. Note that the value sent must be the exact size, in bytes, as accepted by the setting. The “extra” spaces should be filled with zeros (see the “value” column below.)

Example Configuration Parameter: **02 02 00 0A**

Param #	Size	Value
02 <i>(Param #2)</i>	02 <i>(2 Bytes)</i>	00 0A <i>(10)</i>

Param #	Size	Name	Available Values	Default Value
01	<p>This parameter sets the luminance (brightness) level at which night light is turned off. This is a unitless value that can be set to any value from 0 - 10, with a default value of 5. The higher this value, the brighter the ambient light must be to turn off the night light.</p>			
	01	Night Light “Off” Threshold	00 ~ 0A <i>(0 ~ 10)</i>	05 <i>(5)</i>
02	<p>This parameter sets the luminance (brightness) level at which night light is turned on. This is a unitless value that can be set to any value from 0 - 10, with a default value of 5. The lower this value, the dimmer the ambient light must be to turn on the night light.</p>			
	01	Night Light “On” Threshold	00 ~ 0A <i>(0 ~ 10)</i>	05 <i>(5)</i>

Table 5 - Extender Configuration Parameters

# Troubleshooting

## **Q:Help! My Extender paired successfully, but my controller can't see it anymore after I installed it!**

**A:** First, make sure your the Extender is still powered up. Otherwise, the Z-Wave signal is probably weak in that area of your home. Remember that the 120' - 150' range doesn't take into account walls, furniture, and other obstacles. To boost your Z-Wave network coverage, add a few non-battery powered Z-Wave devices between the controller and the furthest device, like the Dome On/Off Plug or Water Main Shut-Off, or of course, the Dome Extender!

## **Q:There's so many words in this manual I don't understand. How can I learn more about Z-Wave?**

**A:** Remember you don't have to understand everything in this manual to start automating your home. Our Quick-Start Guides have all you need to start using any device. For more thorough information about Z-Wave home automation, visit [www.domeha.com/support](http://www.domeha.com/support).

## **Q:I've tried multiple times, but I can't include the Extender in my system.**

**A:** Make sure your device is getting power. Then, follow the instructions under "Factory Reset & Misc. Functions" on page 8 and try going through the inclusion process again. If you are still having issues, please visit [www.domeha.com/support](http://www.domeha.com/support)

## **Q:All of a sudden, my Extender is offline.**

**A:** Check your power supply and make sure your device is getting power. If powered, make sure you still have Z-Wave network coverage. If you are still having issues, visit [www.domeha.com/support](http://www.domeha.com/support).

# Warranty & Support

If you have questions, our trained Customer Service Department is happy to assist you 24 hours a day, 7 days a week. Contact Dome Customer Service as follows: • In North America dial: 1-855-249-1754 • Email Dome at [support@domeHA.com](mailto:support@domeHA.com)

**DO NOT RETURN THIS PRODUCT TO THE STORE OR WEBSITE FROM WHICH IT WAS PURCHASED**

If you believe the product is defective, has a missing or broken part or are having difficulty with it please contact Dome as listed above for a quick and efficient solution to the problem.

Legal Notices: This device complies with part 15 of the FCC rules. Operation is subject to the following two conditions

(1) This device may not cause harmful interference, and (2) this device must accept any interference received, including interference that may cause undesired operation.

Note: This equipment has been tested and found to comply with the limits for a Class B digital device, pursuant to part 15 of the FCC Rules. These limits are designed to provide reasonable protection against harmful interference in a residential installation. This equipment generates, uses and can radiate radio frequency energy and, if not installed and used in accordance with the instructions, may cause harmful interference to radio communications.

However, there is no guarantee that interference will not occur in a particular installation. If this equipment does cause harmful interference to radio or television reception, which can be determined by turning the equipment off and on, the user is encouraged to try to correct the

Interference by one or more of the following measures: Reorient or relocate the receiving antenna; increase the separation between the equipment and the receiver; connect the equipment into an outlet on a circuit different from that to which the receiver is connected. Consult the dealer or an experienced radio/TV technician for help.

This device complies with Industry Canada license-exempt RSS standard(s). Operation is subject to the following two conditions: (1) this device may not cause interference, and (2) this device must accept any interference, including interference that may cause undesired operation of the device.

IC Statement: Le présent appareil est conforme aux CNR d'Industrie Canada applicables aux appareils radio exempts de licence. L'exploitation est autorisée aux deux conditions suivantes : (1) l'appareil ne doit pas produire de brouillage, et (2) l'utilisateur de l'appareil doit accepter tout brouillage radioélectrique subi, même si le brouillage est susceptible d'en compromettre le fonctionnement.

**Changes or modifications not expressly approved by the party responsible for compliance could void the user's authority to operate the equipment.**

Elexa Consumer Products, Inc. ("ECP") warrants to the original retail purchaser ("Purchaser") that the DOME Window/Door sensor (the "Product") will be free of defects in materials or workmanship under use for one (1) year from the date of purchase (the "Warranty period"). For the Purchaser only, if the Product fails to perform as specified during the Warranty Period due to defective parts or faulty workmanship, ECP will repair or replace the defective or damaged parts of the Product. Normal wear and tear is not covered nor is abnormal use, misuse, mishandling, faulty installation, improper shipping, damage caused by disasters such as fire, flood or earthquake, neglect, accident or tampering. This warranty covers only normal use in the United States or Canada.

To obtain warranty service during the Warranty Period, call Dome Customer Service (1-855-249-1754) or email: [support@domeHA.com](mailto:support@domeHA.com) for instructions on sending damaged parts and documentation for a Return Material Authorization (RMA). Products returned to ECP for repair or replacement without authorization will be returned at the sender's expense. All warranty claims must be accompanied by a legible copy of the original receipt showing date and details of purchase. The RMA number must be clearly written on the side of the shipping container in which you return the Product or defective parts. Unless otherwise instructed by ECP, the Product must be sent freight pre-paid to the following address:

Elexa Consumer Products, c/o Promac,  
1153 Timber Dr., Elgin, IL 60123

ECP will repair or replace the defective parts and return them at ECP's cost by a shipping method selected by ECP. When contacting ECP to obtain an RMA, Purchaser may request expedited return shipping at Purchaser's expense.

THIS WARRANTY IS NOT TRANSFERABLE, AND, TO THE MAXIMUM EXTENT PERMITTED BY APPLICABLE LAW IS IN LIEU OF ALL OTHER WARRANTIES, REPRESENTATIONS AND CONDITIONS, EXPRESSED OR IMPLIED, STATUTORY OR OTHERWISE, INCLUDING BUT NOT LIMITED TO THE IMPLIED WARRANTIES OF MERCHANTABILITY AND FITNESS FOR A PARTICULAR PURPOSE. NO OTHER PERSON OR REPRESENTATIVE IS AUTHORIZED TO MAKE ANY OTHER WARRANTY ON BEHALF OF ECP OR ASSUME FOR ECP ANY OTHER LIABILITY IN CONNECTION WITH THE SALE OF THIS PRODUCT. IN NO EVENT WILL ECP BE LIABLE FOR ANY DAMAGES, INCLUDING BUT NOT LIMITED TO INCIDENTAL, SPECIAL OR CONSEQUENTIAL DAMAGES ARISING OUT OF THE USE OR INABILITY TO USE THE PRODUCT, INCLUDING DAMAGES DUE TO ECP'S NEGLIGENCE.

THIS WARRANTY GIVES YOU SPECIFIC LEGAL RIGHTS, AND YOU MAY ALSO HAVE OTHER RIGHTS WHICH VARY FROM STATE TO STATE AND COUNTRY TO COUNTRY.

This marking on the product, accessories or literature indicates that the product and its electronic accessories should not be disposed of with other household waste.

To prevent possible harm to the environment or human health from uncontrolled waste disposal, please separate these items from other types of waste and recycle them responsibly to promote the sustainable reuse of material resources.

Household users should contact either the retailer where they purchased this product, or their government office, for details of where and how they can take these items for Environmentally safe recycling.

Business users should contact their supplier and check the terms and conditions of the purchase contract. This product and its electronic accessories should not be mixed with other wastes for disposal.

This marking on the battery, manual or packaging indicates that the batteries in this product should not be disposed of with other household waste. Where marked, the chemical symbols Hg, Cd or Pb indicate that the battery contains mercury, cadmium or lead above the reference levels in EC Directive 2006/66. If batteries are not properly disposed of, these substances can cause harm to human health or the environment.