

### Label

Back  
Position on the unit

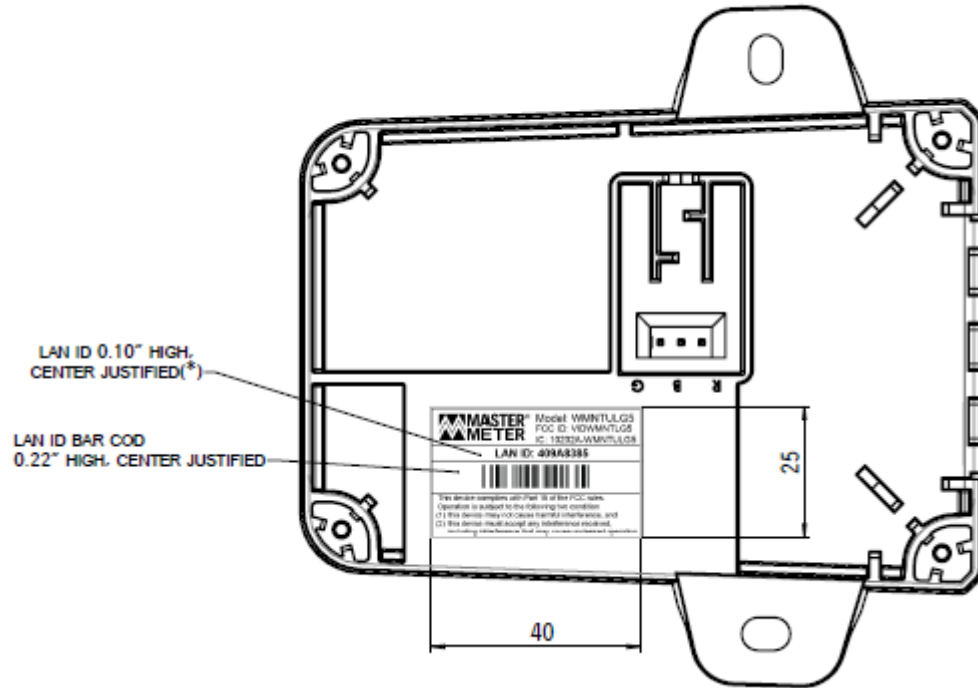

REV.	DESCRIPTION	REFERENCE	DATE	APPROVED
------	-------------	-----------	------	----------

Front  
Position on the unit

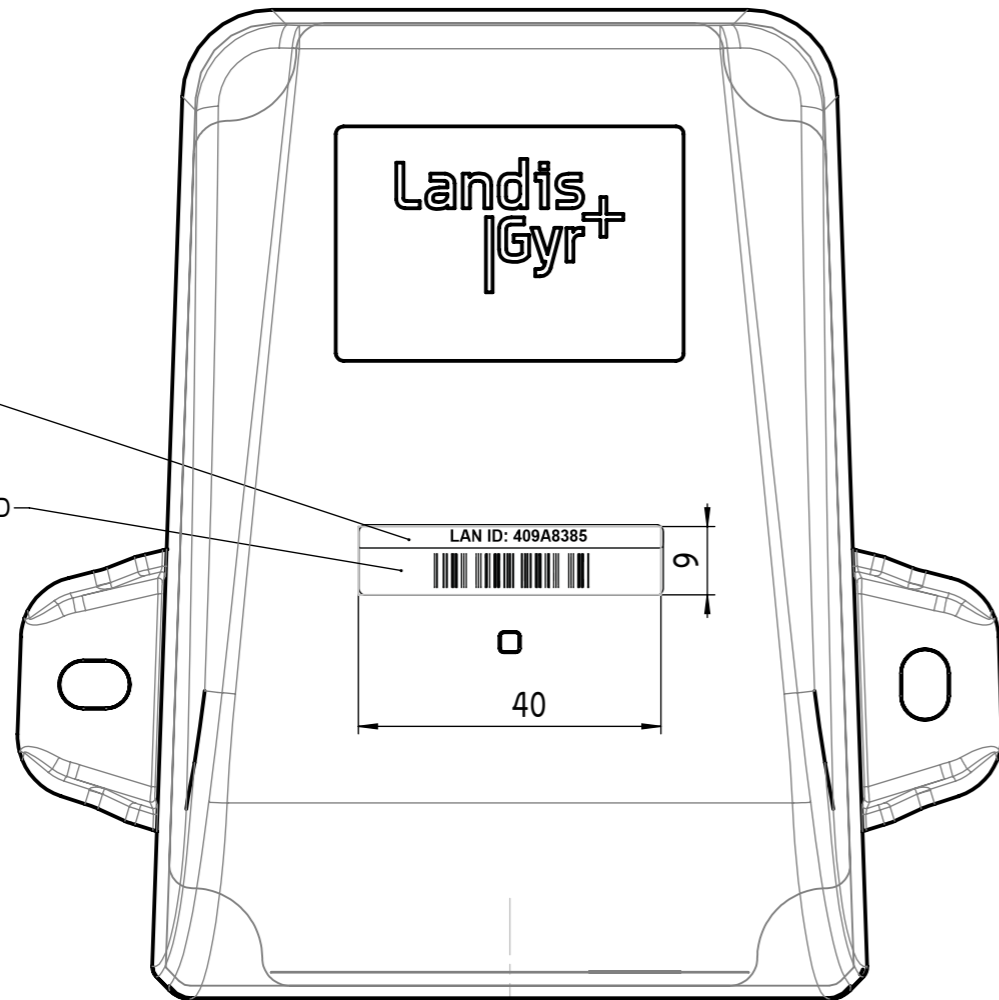

LAN ID 0.10" HIGH,  
CENTER JUSTIFIED(\*)

LAN ID BAR COD  
0.22" HIGH, CENTER JUSTIFIED

Back  
Position on the unit

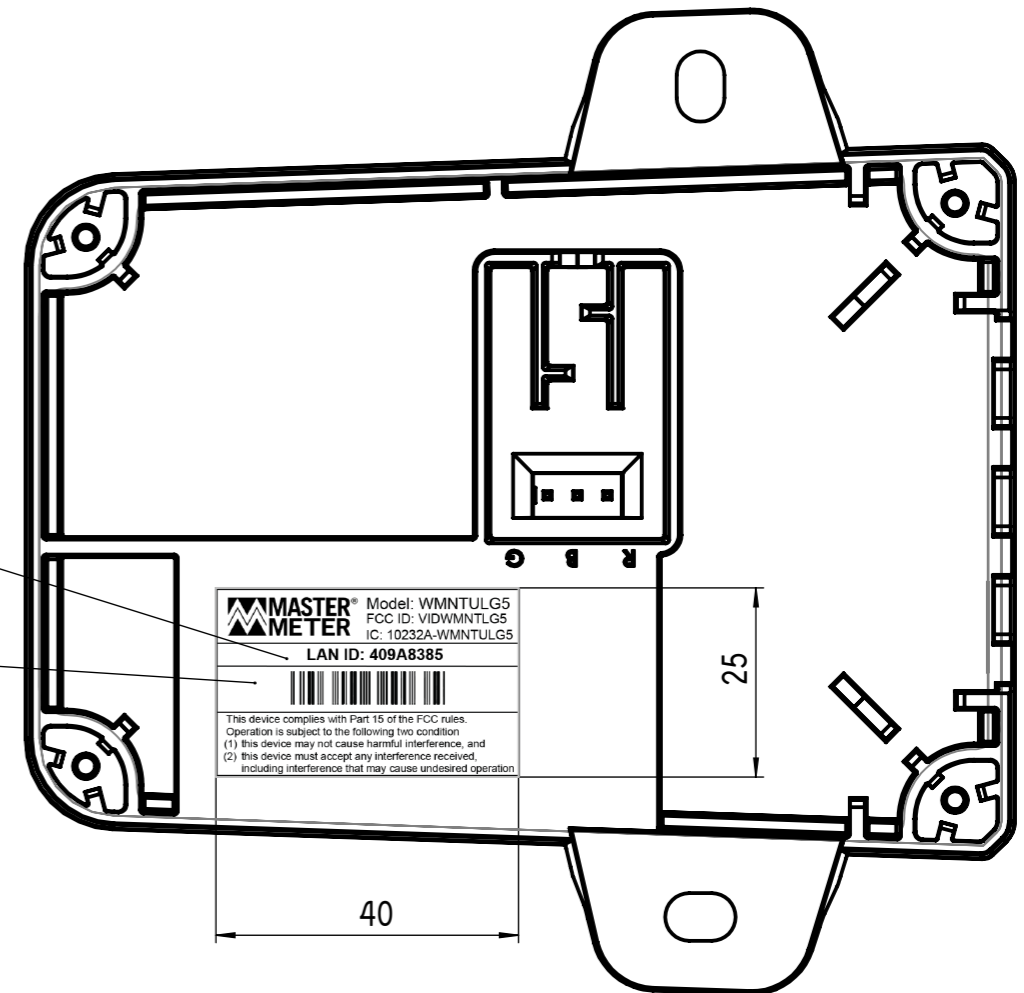

LAN ID 0.10" HIGH,  
CENTER JUSTIFIED(\*)

LAN ID BAR COD  
0.22" HIGH, CENTER JUSTIFIED

\* LAN ID are changeable numbers (409A8385 - for example only)  
DIMENSIONS FOR REFERENCE ONLY

Arad Measuring Technologies  
ENGINEERING DEPARTMENT

Approved By:  
Date:

WEIGHT [g] :

MATERIAL [generic name] : P/N 99100529/B ; 99100530/B

	NAME	DATE	NAME	PROD.PROC.
DRAWN	Yana	17/04/2019	NILE WALL MOUNT ARTWORK 3 WIRE ENCODER NICOR	A3
DESIGNED	Yoav Tov	07/08/2018		
CHECKED			ISO 2768	0.5-6 6-30 30-120 120-400 400-1000 ANGULAR
APPROVED			TOLERANCE	±0.1 ±0.2 ±0.3 ±0.5 ±0.8 ±30'

SHEET 1 OF 1 DR 1	UNLESS OTHERWISE SPECIFIED DIMENSIONS ARE IN MILLIMETERS	SCALE 1:1 ( )	<b>ARAD</b> TECHNOLOGIES Water Measuring Technologies
CAT.NO./ REV: 9 75 108 59 /			

NOTES:

1. DRAWING DESCRIBS ARTWORK OR GRAPHIC REQUIREMENTS ON PARTS OR SUB ASSEMBLY.
- 2.0 REQUIREMENTS
- 2.1 ARTWORK:
  - 2.1.1 IF ARAD TECHNOLOGIES HAS PROVIDED AN ARTWORK IT GOVERNS THE ARTWORK PRESENTED ON DRAWING.
  - 2.1.2 IF VENDOR HAS PROVIDED THE ARTWORK, IT WILL GOVERN THE DRAWING, IF A FORMAL APPROVAL WAS GIVEN.
3. ENGRAVING PROCESS WITH LASER ETCHING
4. QUALITY CONTROL
  - 4.1 THE ARTWORK IS OF AN APPEARANCE CONCERN.
    - 4.1.1 100% VISUAL INSPECTION:
      - 4.1.1.2 NO BLEMISH OF ARTWORK
      - 4.1.1.3 EVEN TONE AND FILL
  - 4.2 PRODUCTION INSPECTION.
    - 4.2.1 DOCUMENTATION: VENDOR SHOULD PROVIDE FOR PRODUCTION INSPECTION:
      - 4.2.1.1 COC OF ALL RAW MATERIALS
5. PACKAGING
  - 5.1 PARTS SHOULD BE ADEQUATELY PACKED TO PREVENT DAMAGE IN STORAGE AND TRANSPORATION
  - 5.2 DATE CODE AND PART NUMBER SHOULD BE MARKED ON BACKING PAPER ON PACKAGE.

Dwg: C:\Arad\_Tech\_Vault\products\wall mount\97510859\_NILE WALL MOUNT ARTWORK 3 WIRE ENCODER NICOR  
Model: C:\Arad\_Tech\_Vault\products\wall mount\97510859\_NILE WALL MOUNT ARTWORK 3 WIRE ENCODER NICOR  
Model Rev:

A  
B  
C  
D  
E  
F  
G  
H  
J  
K  
L  
M  
N  
P  
Q  
R  
S  
T  
U  
V  
W  
X  
Y  
Z

**“WMNTULG5” label location**

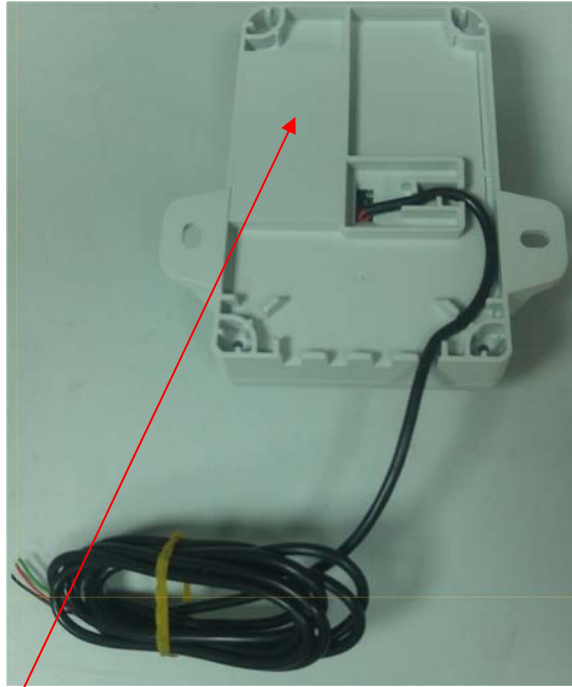

Label with FCC ID:VIDWMNTLG5 and IC:10232A-WMNTULG5 will be placed here as shown in the drawing above.