



Hermon Laboratories Ltd.  
P.O. Box 23, Binyamina 3055001, Israel  
Tel. +972 4628 8001  
Fax. +972 4628 8277  
E-mail: mail@hermonlabs.com

# TEST REPORT

ACCORDING TO:

FCC 47 CFR PART 15 subpart C, section 15.249 and subpart B

RSS-210 Issue 9:2016, RSS-Gen Issue 5:2018, ICES-003 Issue 6:2016

FOR:

**ARAD TECHNOLOGIES**

**Water meter**

**Model: INTERPRETER5**

**FCC ID: VIDINTRLG5**

**IC: 10232A-INTERLG5**

This report is in conformity with ISO/ IEC 17025. The "A2LA Accredited" symbol endorsement applies only to the tests and calibrations that are listed in the scope of Hermon Laboratories accreditation. The test results relate only to the items tested. This test report shall not be reproduced in any form except in full with the written approval of Hermon Laboratories Ltd.



## Table of contents

1	Applicant information.....	3
2	Equipment under test attributes .....	3
3	Manufacturer information .....	3
4	Test details.....	3
5	Tests summary.....	4
6	EUT description.....	5
6.1	General information.....	5
6.2	Test configuration.....	5
6.3	Changes made in EUT .....	5
6.4	Transmitter characteristics .....	6
7	Transmitter tests according to 47CFR part 15 subpart C requirements .....	7
7.1	Field strength of emissions.....	7
7.2	Occupied bandwidth test.....	23
7.3	Band edge emission.....	32
7.4	Antenna requirements .....	37
8	Unintentional emission tests according to 47CFR part 15 subpart B .....	38
8.1	Radiated emission measurements .....	38
9	APPENDIX A Test equipment and ancillaries used for tests.....	41
10	APPENDIX B Test equipment correction factors.....	42
11	APPENDIX C Measurement uncertainties .....	45
12	APPENDIX D Test laboratory description .....	46
13	APPENDIX E Specification references.....	47
14	APPENDIX F Abbreviations and acronyms.....	48



## 1 Applicant information

**Client name:** ARAD TECHNOLOGIES  
**Address:** POB 537, HaMada 4, Yokneam Ind. Zone, Yokneam Ilit 20692, Israel  
**Telephone:** 04-9935222 Ext.277  
**Fax:** 04-9935227  
**E-mail:** [viorel.negreanu@aradtec.com](mailto:viorel.negreanu@aradtec.com)  
**Contact name:** Mr.Vily Negreanu

## 2 Equipment under test attributes

**Product name:** Water meter  
**Product type:** Transceiver  
**Model(s):** INTERPRETER5  
**Serial number:** 18M00A34E2  
**Hardware version:** P4  
**Software release:** 07.02/08.02  
**Receipt date:** 10-Apr-19

## 3 Manufacturer information

**Manufacturer name:** ARAD TECHNOLOGIES  
**Address:** POB 537, HaMada 4, Yokneam Ind. Zone, Yokneam Ilit 20692, Israel  
**Telephone:** 04-9935222 Ext.277  
**Fax:** 04-9935227  
**E-Mail:** [viorel.negreanu@aradtec.com](mailto:viorel.negreanu@aradtec.com)  
**Contact name:** Mr.Vily Negreanu

## 4 Test details

**Project ID:** 33388  
**Location:** Hermon Laboratories Ltd. P.O. Box 23, Binyamina 3055001, Israel  
**Test started:** 19-May-19  
**Test completed:** 10-Jun-19  
**Test specification(s):** FCC 47 CFR PART 15 subpart C, section 15.249 and subpart B  
RSS-210 Issue 9:2016, RSS-Gen Issue 5:2018, ICES-003 Issue 6:2016

## 5 Tests summary

### Test

#### Transmitter characteristics

Section 15.249(a)(d) / RSS-210 section B.10, Field strength of emissions	Pass
Section 15.215(c), Occupied bandwidth	Pass
Section 15.249(d) / RSS-210 section C.4, Band edge emissions	Pass
Section 15.203, Antenna requirement	Pass

#### Unintentional emissions



Section 15.109 / RSS-Gen, section 7.3, ICES-003, Radiated emission	Pass
--	------

\* Pass, the exhibit to the application of certification is provided.

This test report supersedes the previously issued test report identified by Doc ID: ARARAD\_FCC.33388\_Int

Testing was completed against all relevant requirements of the test standard. The results obtained indicate that the product under test complies in full with the requirements tested.

The test results relate only to the items tested. Pass/ fail decision was based on nominal values.

	Name and Title	Date	Signature
<b>Tested by:</b>	Mr. A. Morozov test engineer EMC & Radio	26-May-19 – 10-Jun-19	
<b>Reviewed by:</b>	Mrs. S Peysahov Sheynin test engineer EMC & Radio	02-Sep-19 – 04-Sep-19	
<b>Approved by:</b>	Mr. S. Samokha, technical manager, EMC and Radio	15-Oct-19	

## 6 EUT description

Note: The following data in this clause is provided by the customer and represents his sole responsibility

### 6.1 General information

Measurement head with embedded radio and antenna. Unit can be attached to various devices that create rotating magnetic field in case of water flow. The Measurement head senses the magnetic field, decodes the read and sends it to the network.

The device has basically 2 modes of operation –

1. “Network mode” – in this mode unit is connected to the network and should meet FCC part 15.247.
2. Technician mode –
  - a. Unit operated by a technician.
  - b. Unit works at single channel.

For the technician mode, unit should meet FCC part 15.249.

This test report is provided to support certification per FCC part 15 subpart C section 15.249.

### 6.2 Test configuration

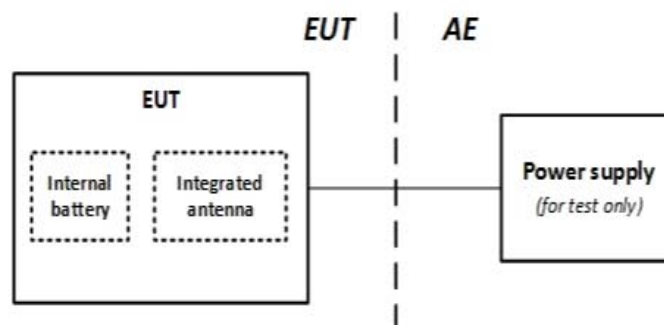

### 6.3 Changes made in EUT

No changes were performed in the EUT.



### 6.4 Transmitter characteristics

<b>Type of equipment</b>					
V	Stand-alone (Equipment with or without its own control provisions)				
	Combined equipment (Equipment where the radio part is fully integrated within another type of equipment)				
	Plug-in card (Equipment intended for a variety of host systems)				
<b>Assigned frequency range</b>		902 - 928 MHz			
<b>Operating frequency range</b>		902.3 – 927.8 MHz for 2FSK 9.6 kbps 902.4 – 927.6 MHz for 2FSK 19.2 kbps 902.4 – 927.6 MHz for 2FSK 38.4 kbps 903.8 – 927.4 MHz for GFSK 50.0 kbps			
<b>Maximum field strength</b>		93.24 dB(μV/m) at 3 m test distance for 2FSK 9.6 kbps 92.99 dB(μV/m) at 3 m test distance for 2FSK 19.2 kbps 93.89 dB(μV/m) at 3 m test distance for 2FSK 38.4 kbps 92.84 dB(μV/m) at 3 m test distance for GFSK 50.0 kbps			
<b>Is transmitter output power variable?</b>	V	No			
	Yes	continuous variable			
		stepped variable with stepsize, software controlled			dB
		Maximum field strength			
<b>Antenna connection</b>					
V	unique coupling	standard connector	Integral	with temporary RF connector	
				without temporary RF connector	
<b>Antenna/s technical characteristics</b>					
Type	Manufacturer		Model number	Gain	
Integrated	AT		NA	0 dBi	
<b>Type of modulation / data rates</b>		2FSK 9.6 kbps 2FSK 19.2 kbps 2FSK 38.4 kbps GFSK 50.0 kbps			
<b>Transmitter duty cycle supplied for test</b>		100%			
<b>Transmitter power source</b>					
V	Battery	<b>Nominal rated voltage</b>	3.6 VDC	Battery type	Lithium
	DC	<b>Nominal rated voltage</b>			
	AC mains	<b>Nominal rated voltage</b>		Frequency	
<b>Common power source for transmitter and receiver</b>				V	yes no



<b>Test specification:</b> Section 15.249(a)(d)/RSS-210, section B.10, Field strength of emissions			
<b>Test procedure:</b> ANSI C63.10, Section 6.5, 6.6			
<b>Test mode:</b> Compliance		<b>Verdict:</b> PASS	
<b>Date(s):</b> 26-May-19			
<b>Temperature:</b> 26 °C	<b>Relative Humidity:</b> 47 %	<b>Air Pressure:</b> 1015 hPa	<b>Power:</b> 3.6 VDC
<b>Remarks:</b>			

## 7 Transmitter tests according to 47CFR part 15 subpart C requirements

### 7.1 Field strength of emissions

#### 7.1.1 General

This test was performed to measure field strength of fundamental and spurious emissions from the EUT. Specification test limits are given in Table 7.1.1, Table 7.1.2 and Table 7.1.3.

Table 7.1.1 Radiated fundamental emission limits

Fundamental frequency, MHz	Field strength at 3 m, dB( $\mu$ V/m)		
	Peak	Average	Quasi-Peak
<b>902 – 928</b>	<b>NA</b>	<b>NA</b>	<b>94</b>
2400 – 2483.5	114.0	94.0	NA
5725 – 5875	114.0	94.0	NA
24000 – 24250*	128.0	108.0	NA

\* The band is not used according to RSS-210 section A2.9

Table 7.1.2 Harmonics limits

Fundamental frequency, MHz	Field strength at 3 m, dB( $\mu$ V/m)	
	Peak	Average
<b>902 – 928</b>	<b>74.0</b>	<b>54.0</b>
2400 – 2483.5	74.0	54.0
5725 – 5875	74.0	54.0
24000 – 24250*	88.0	68.0

\* The band is not used according to RSS-210 section A2.9



<b>Test specification: Section 15.249(a)(d)/RSS-210, section B.10, Field strength of emissions</b>			
<b>Test procedure:</b> ANSI C63.10, Section 6.5, 6.6			
<b>Test mode:</b> Compliance		<b>Verdict: PASS</b>	
<b>Date(s):</b> 26-May-19			
<b>Temperature:</b> 26 °C	<b>Relative Humidity:</b> 47 %	<b>Air Pressure:</b> 1015 hPa	<b>Power:</b> 3.6 VDC
<b>Remarks:</b>			

Table 7.1.3 Radiated spurious emissions limits (other than harmonics)

Frequency, MHz	Field strength at 3 m, dB(μV/m)*			Attenuation below carrier
	Peak	Quasi Peak	Average	
0.009 – 0.090	148.5 – 128.5	NA	128.5 – 108.5**	50 dBc (whichever is the less stringent)
0.090 – 0.110	NA	108.5 – 106.8**	NA	
0.110 – 0.490	126.8 – 113.8	NA	106.8 – 93.8**	
0.490 – 1.705	NA	73.8 – 63.0**	NA	
1.705 – 30.0*		69.5		
30 – 88		40.0		
88 – 216		43.5		
216 – 960		46.0		
960 - 1000		54.0		
Above 1000		74.0		

\*- The limit for 3 m test distance was calculated using the inverse square distance extrapolation factor as follows:

$$\text{Lim}_{S_2} = \text{Lim}_{S_1} + 40 \log (S_1/S_2),$$

where S<sub>1</sub> and S<sub>2</sub> – standard defined and test distance respectively in meters.

\*\*- The limit decreases linearly with the logarithm of frequency.

Note: The above field strength limits applied from the lowest radio frequency generated in the device, without going below 9 kHz up to the tenth harmonic of the highest fundamental frequency but not exceeding 40 GHz for intentional radiators operated below 10 GHz and up to the fifth harmonic of the highest fundamental frequency but not exceeding 100 GHz for intentional radiators operated above 10 GHz.

**7.1.2 Test procedure for spurious emission field strength measurements in 9 kHz to 30 MHz band**

7.1.2.1 The EUT was set up as shown in Figure 7.1.1, energized and the performance check was conducted.

7.1.2.2 The measurements were performed in typical EUT position.

7.1.2.3 The specified frequency range was investigated with antenna connected to spectrum analyzer/ EMI receiver. To find maximum radiation the turntable was rotated 360° and the measuring antenna was rotated around its vertical axis.

**7.1.3 Test procedure for spurious emission field strength measurements above 30 MHz**

7.1.3.1 The EUT was set up as shown in Figure 7.1.2, energized and the performance check was conducted.

7.1.3.2 The measurements were performed in typical EUT position.

7.1.3.3 The specified frequency range was investigated with antenna connected to spectrum analyzer/ EMI receiver. To find maximum radiation the turntable was rotated 360°, the measuring antenna height was changed from 1 to 4 m, its polarization was switched from vertical to horizontal.





<b>Test specification:</b> Section 15.249(a)(d)/RSS-210, section B.10, Field strength of emissions			
<b>Test procedure:</b> ANSI C63.10, Section 6.5, 6.6			
<b>Test mode:</b> Compliance		<b>Verdict:</b> PASS	
<b>Date(s):</b> 26-May-19			
<b>Temperature:</b> 26 °C	<b>Relative Humidity:</b> 47 %	<b>Air Pressure:</b> 1015 hPa	<b>Power:</b> 3.6 VDC
<b>Remarks:</b>			

Figure 7.1.1 Setup for spurious emission field strength measurements below 30 MHz

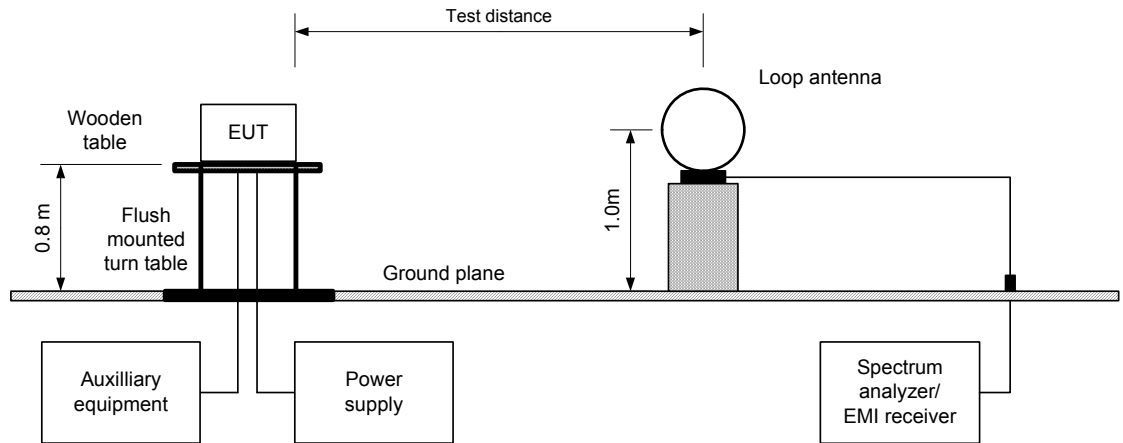
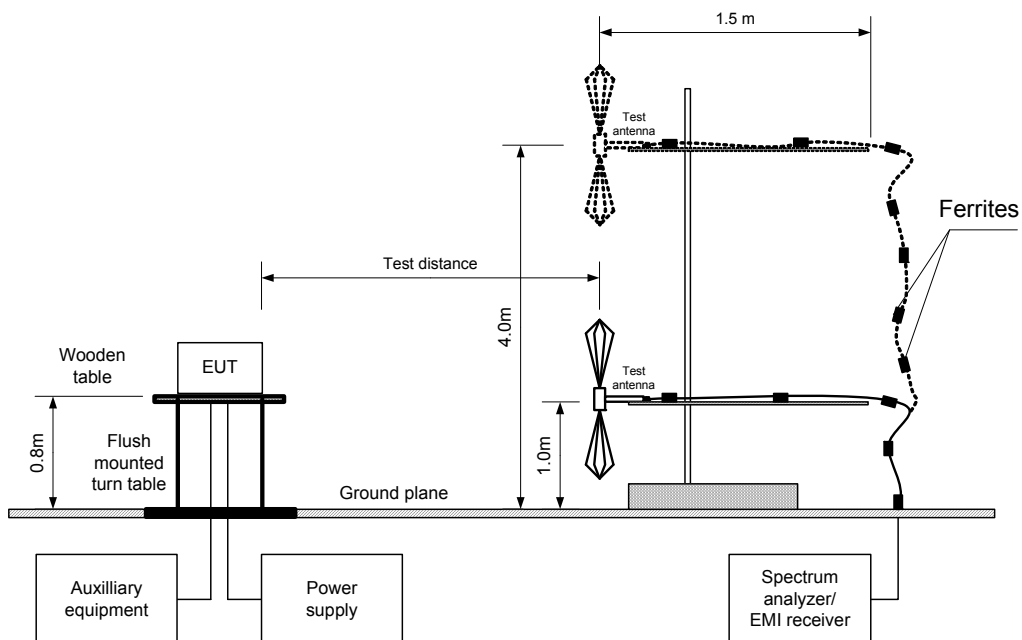

Figure 7.1.2 Setup for spurious emission field strength measurements in 30 -1000 MHz





<b>Test specification: Section 15.249(a)(d)/RSS-210, section B.10, Field strength of emissions</b>			
<b>Test procedure:</b> ANSI C63.10, Section 6.5, 6.6			
<b>Test mode:</b> Compliance		<b>Verdict:</b> PASS	
<b>Date(s):</b> 26-May-19			
<b>Temperature:</b> 26 °C	<b>Relative Humidity:</b> 47 %	<b>Air Pressure:</b> 1015 hPa	<b>Power:</b> 3.6 VDC
<b>Remarks:</b>			

Figure 7.1.3 Setup for spurious emission field strength measurements above 1000 MHz

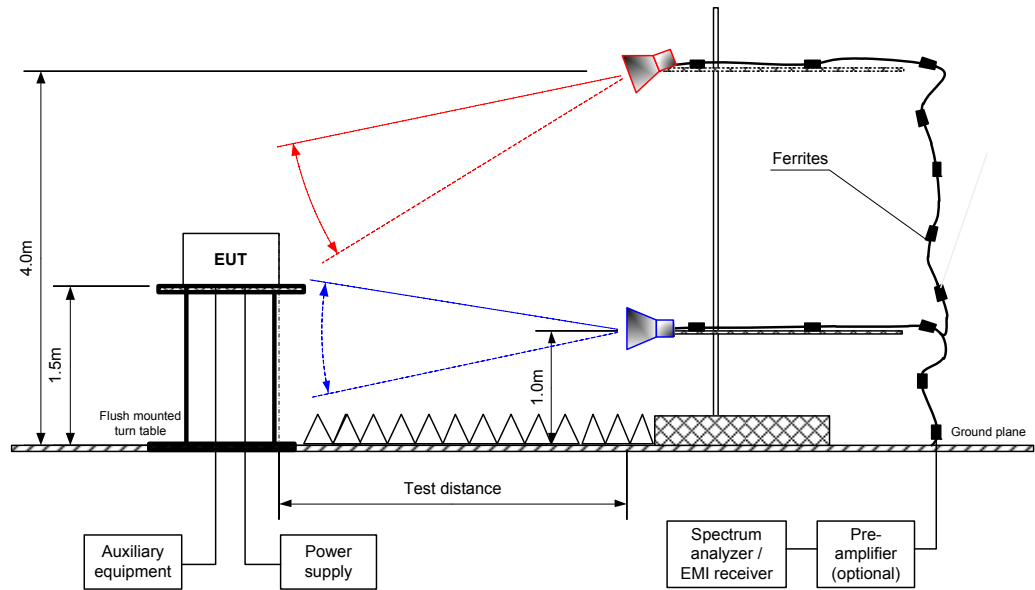



<b>Test specification:</b> Section 15.249(a)(d)/RSS-210, section B.10, Field strength of emissions			
<b>Test procedure:</b> ANSI C63.10, Section 6.5, 6.6			
<b>Test mode:</b> Compliance		<b>Verdict:</b> PASS	
<b>Date(s):</b> 26-May-19			
<b>Temperature:</b> 26 °C	<b>Relative Humidity:</b> 47 %	<b>Air Pressure:</b> 1015 hPa	<b>Power:</b> 3.6 VDC
<b>Remarks:</b>			

Table 7.1.4 Field strength of fundamental emission and spurious emissions

TEST DISTANCE: 3 m  
 EUT POSITION: Typical  
 TRANSMITTER OUTPUT POWER SETTINGS: Maximum  
 DETECTOR USED: Peak  
 RESOLUTION BANDWIDTH: 1.0 kHz (9 kHz – 150 kHz)  
 9.0 kHz (150 kHz – 30 MHz)  
 120 kHz (30 MHz – 1000 MHz)  
 1.0 MHz (above 1000 MHz)  
 VIDEO BANDWIDTH: ≥ Resolution bandwidth  
 TEST ANTENNA TYPE: Active loop (9 kHz – 30 MHz)  
 Biconilog (30 MHz – 1000 MHz)  
 Double ridged guide (above 1000 MHz)

INVESTIGATED FREQUENCY RANGE: 0.009 – 1000 MHz

Frequency, MHz	Antenna		Azimuth, degrees*	Peak emission, dB(μV/m)	Quasi-peak			Verdict
	Pol.	Height, m			Measured emission, dB(μV/m)	Limit, dB(μV/m)	Margin, dB**	
<b>Fundamental emission with 2FSK 9.6 kbps</b>								
902.3	Ver	1.00	338	92.59	92.59	94.0	-1.41	Pass
915.0	Ver	1.00	344	93.24	93.24	94.0	-0.76	
927.8	Ver	1.00	239	92.82	92.82	94.0	-1.18	
<b>Fundamental emission with 2FSK 19.2 kbps</b>								
902.3	Ver	1.00	324	92.79	92.79	94.0	-1.21	Pass
915.0	Ver	1.00	0	92.99	92.99	94.0	-1.01	
927.8	Ver	1.00	350	92.40	92.40	94.0	-1.60	
<b>Fundamental emission with 2FSK 38.4 kbps</b>								
902.4	Ver	1.00	0	93.25	93.25	94.0	-0.75	Pass
915.0	Ver	1.00	0	93.89	93.89	94.0	-0.11	
927.6	Ver	1.00	352	92.36	92.36	94.0	-1.64	
<b>Fundamental emission with GFSK 50 kbps</b>								
903.8	Ver	1.00	335	91.82	91.82	94.0	-2.18	Pass
915.0	Ver	1.00	352	92.84	92.84	94.0	-1.16	
927.4	Ver	1.00	0	92.66	92.66	94.0	-1.34	
<b>Spurious emissions at low, mid, high frequencies</b> No emissions were found								Pass

INVESTIGATED FREQUENCY RANGE: 1000 - 9500 MHz

F, MHz	Antenna		Azimuth, degrees*	Peak field strength			Avr factor, dB	Average field strength			Verdict
	Pol.	Height, m		Measured, dB(μV/m)	Limit, dB(μV/m)	Margin, dB**		Measured, dB(μV/m)	Limit, dB(μV/m)	Margin, dB**	
<b>Spurious emissions at low frequency</b>											
1169.75	Vert	2.04	32	39.94	74.0	-34.06	NA	34.08	54.0	-19.92	Pass
<b>Spurious emissions at mid frequency</b>											
1130.85	Vert	2.04	41	40.05	74.0	-33.95	NA	35.14	54.0	-18.86	Pass
<b>Spurious emissions at high frequency</b>											
1131.13	Vert	2.04	18	40.21	74.0	-33.79	NA	34.88	54.0	-19.12	Pass

\*- EUT front panel refers to 0 degrees position of turntable.

\*\*- Margin, dB =Measured (calculated) value, dB(μV/m)-Limit, dB(μV/m).



<b>Test specification: Section 15.249(a)(d)/RSS-210, section B.10, Field strength of emissions</b>			
<b>Test procedure:</b> ANSI C63.10, Section 6.5, 6.6			
<b>Test mode:</b> Compliance		<b>Verdict: PASS</b>	
<b>Date(s):</b> 26-May-19			
<b>Temperature:</b> 26 °C	<b>Relative Humidity:</b> 47 %	<b>Air Pressure:</b> 1015 hPa	<b>Power:</b> 3.6 VDC
<b>Remarks:</b>			

Table 7.1.5 Average factor calculation

Transmission pulse		Transmission burst		Transmission train duration, ms	Average factor, dB
Duration, ms	Period, ms	Duration, ms	Period, ms		
NA	NA	NA	NA	NA	NA

\*- Average factor was calculated as follows

for pulse train shorter than 100 ms:

$$Average\ factor = 20 \times \log_{10} \left( \frac{Pulse\ duration}{Pulse\ period} \times \frac{Burst\ duration}{Train\ duration} \times Number\ of\ bursts\ within\ pulse\ train \right)$$

for pulse train longer than 100 ms:

$$Average\ factor = 20 \times \log_{10} \left( \frac{Pulse\ duration}{Pulse\ period} \times \frac{Burst\ duration}{100\ ms} \times Number\ of\ bursts\ within\ 100\ ms \right)$$

Reference numbers of test equipment used

HL 0446	HL 3903	HL 4360	HL 4933	HL 5288	HL 5405		
---------	---------	---------	---------	---------	---------	--	--

Full description is given in Appendix A.

Plot 7.1.1 Radiated emission measurements at the low fundamental frequency with 2FSK 9.6 kbps

TEST SITE: Semi anechoic chamber  
TEST DISTANCE: 3 m  
ANTENNA POLARIZATION: Vertical and horizontal

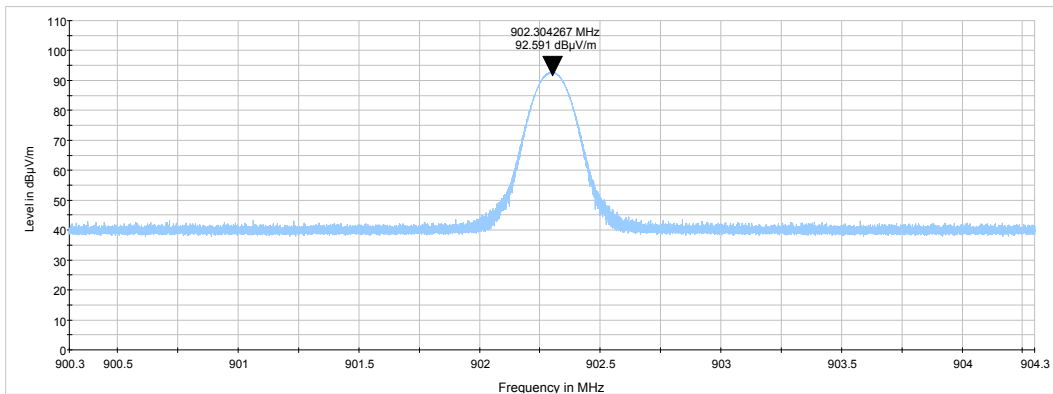



HERMON LABORATORIES

<b>Test specification: Section 15.249(a)(d)/RSS-210, section B.10, Field strength of emissions</b>			
<b>Test procedure:</b> ANSI C63.10, Section 6.5, 6.6			
<b>Test mode:</b> Compliance		<b>Verdict:</b> PASS	
<b>Date(s):</b> 26-May-19			
<b>Temperature:</b> 26 °C	<b>Relative Humidity:</b> 47 %	<b>Air Pressure:</b> 1015 hPa	<b>Power:</b> 3.6 VDC
<b>Remarks:</b>			

**Plot 7.1.2 Radiated emission measurements at the mid fundamental frequency with 2FSK 9.6 kbps**

TEST SITE: Semi anechoic chamber  
TEST DISTANCE: 3 m  
ANTENNA POLARIZATION: Vertical and horizontal

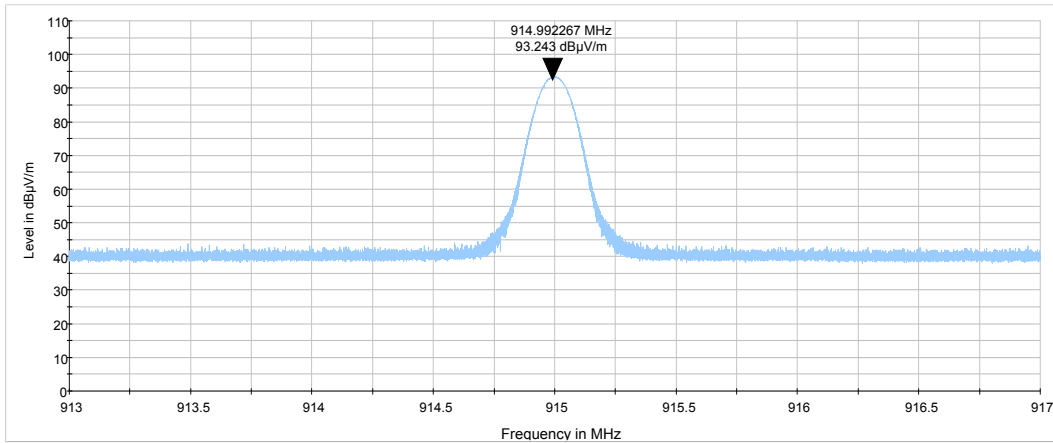

**Plot 7.1.3 Radiated emission measurements at the high fundamental frequency with 2FSK 9.6 kbps**

TEST SITE: Semi anechoic chamber  
TEST DISTANCE: 3 m  
ANTENNA POLARIZATION: Vertical and horizontal

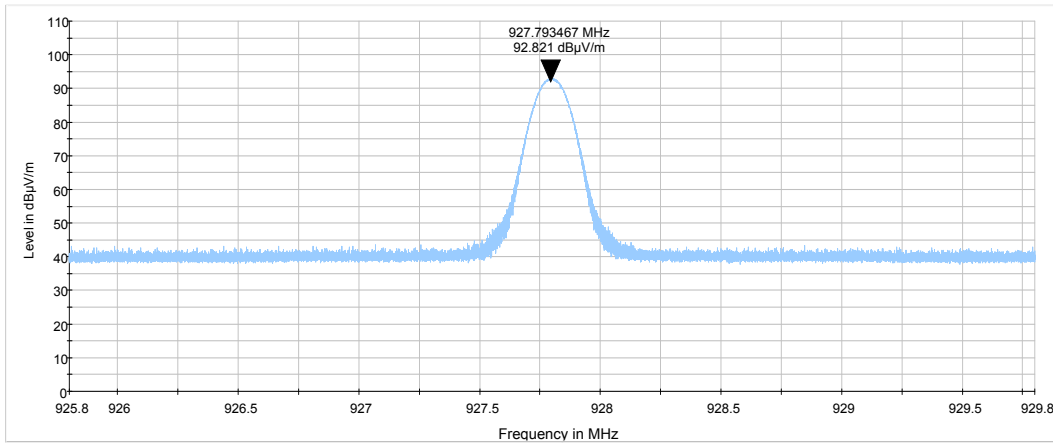



<b>Test specification: Section 15.249(a)(d)/RSS-210, section B.10, Field strength of emissions</b>			
<b>Test procedure:</b> ANSI C63.10, Section 6.5, 6.6			
<b>Test mode:</b> Compliance		<b>Verdict:</b> PASS	
<b>Date(s):</b> 26-May-19			
<b>Temperature:</b> 26 °C	<b>Relative Humidity:</b> 47 %	<b>Air Pressure:</b> 1015 hPa	<b>Power:</b> 3.6 VDC
<b>Remarks:</b>			

**Plot 7.1.4 Radiated emission measurements at the low fundamental frequency with 2FSK 19.2 kbps**

TEST SITE: Semi anechoic chamber  
TEST DISTANCE: 3 m  
ANTENNA POLARIZATION: Vertical and horizontal

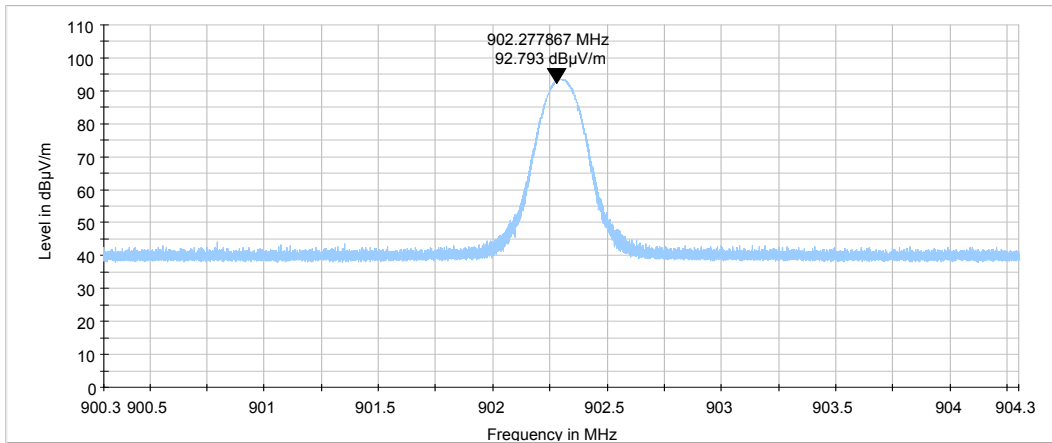

**Plot 7.1.5 Radiated emission measurements at the mid fundamental frequency with 2FSK 19.2 kbps**

TEST SITE: Semi anechoic chamber  
TEST DISTANCE: 3 m  
ANTENNA POLARIZATION: Vertical and horizontal

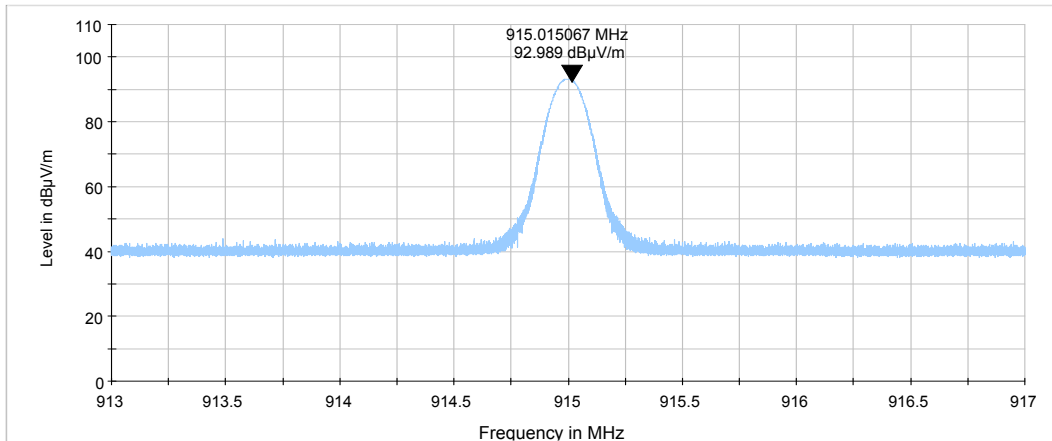



HERMON LABORATORIES

<b>Test specification: Section 15.249(a)(d)/RSS-210, section B.10, Field strength of emissions</b>			
<b>Test procedure:</b> ANSI C63.10, Section 6.5, 6.6			
<b>Test mode:</b> Compliance		<b>Verdict:</b> PASS	
<b>Date(s):</b> 26-May-19			
<b>Temperature:</b> 26 °C	<b>Relative Humidity:</b> 47 %	<b>Air Pressure:</b> 1015 hPa	<b>Power:</b> 3.6 VDC
<b>Remarks:</b>			

**Plot 7.1.6 Radiated emission measurements at the high fundamental frequency with 2FSK 19.2 kbps**

TEST SITE: Semi anechoic chamber  
TEST DISTANCE: 3 m  
ANTENNA POLARIZATION: Vertical and horizontal

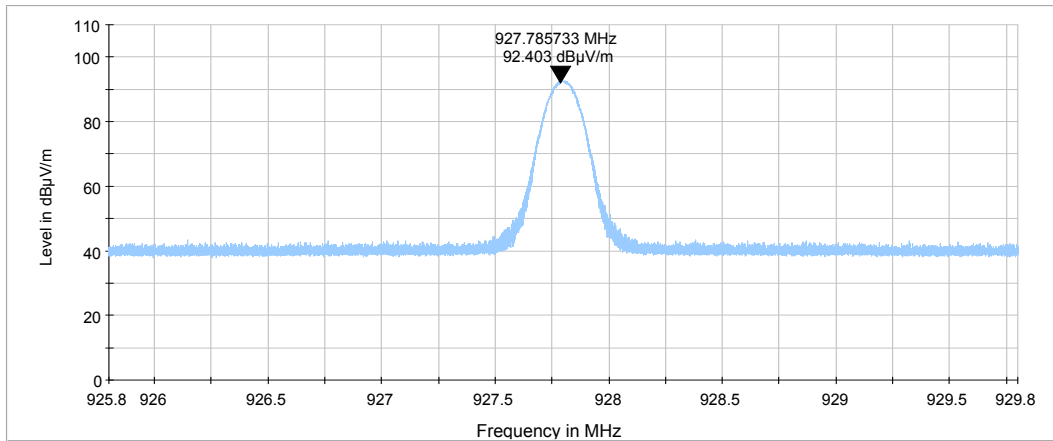

**Plot 7.1.7 Radiated emission measurements at the low fundamental frequency with 2FSK 38.4 kbps**

TEST SITE: Semi anechoic chamber  
TEST DISTANCE: 3 m  
ANTENNA POLARIZATION: Vertical and horizontal

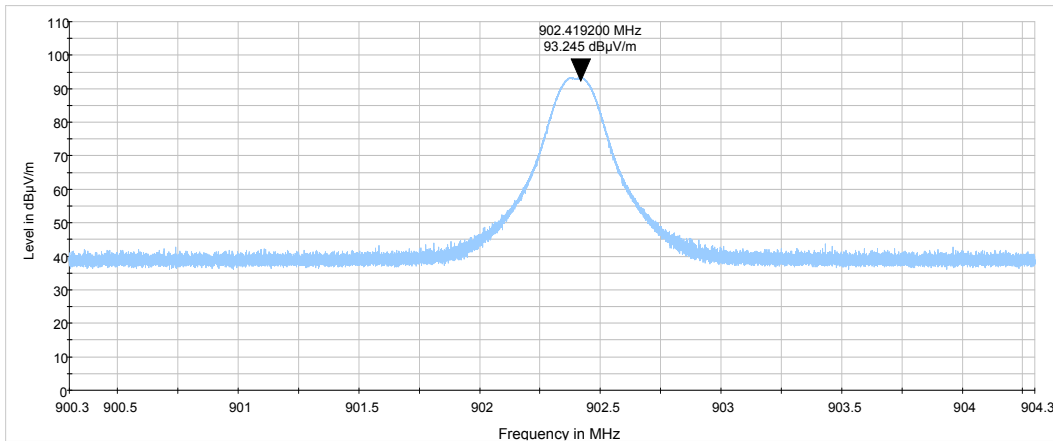



HERMON LABORATORIES

<b>Test specification:</b> Section 15.249(a)(d)/RSS-210, section B.10, Field strength of emissions			
<b>Test procedure:</b> ANSI C63.10, Section 6.5, 6.6			
<b>Test mode:</b> Compliance		<b>Verdict:</b> PASS	
<b>Date(s):</b> 26-May-19			
<b>Temperature:</b> 26 °C	<b>Relative Humidity:</b> 47 %	<b>Air Pressure:</b> 1015 hPa	<b>Power:</b> 3.6 VDC
<b>Remarks:</b>			

**Plot 7.1.8 Radiated emission measurements at the mid fundamental frequency with 2FSK 38.4 kbps**

TEST SITE: Semi anechoic chamber  
TEST DISTANCE: 3 m  
ANTENNA POLARIZATION: Vertical and horizontal

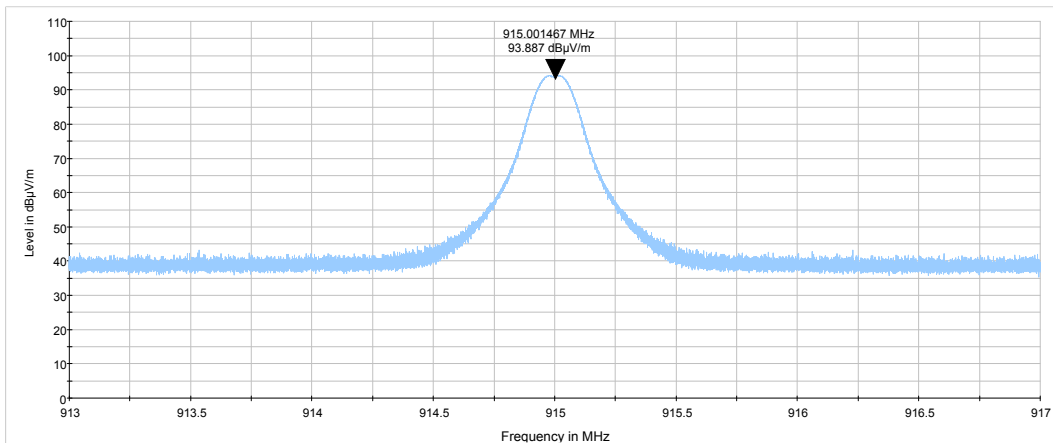

**Plot 7.1.9 Radiated emission measurements at the high fundamental frequency with 2FSK 38.4 kbps**

TEST SITE: Semi anechoic chamber  
TEST DISTANCE: 3 m  
ANTENNA POLARIZATION: Vertical and horizontal

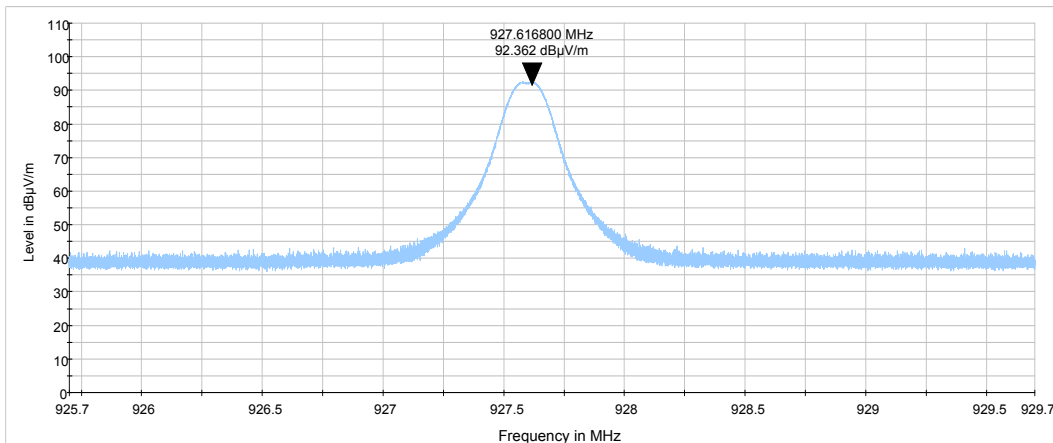





HERMON LABORATORIES

<b>Test specification: Section 15.249(a)(d)/RSS-210, section B.10, Field strength of emissions</b>			
<b>Test procedure:</b> ANSI C63.10, Section 6.5, 6.6			
<b>Test mode:</b> Compliance		<b>Verdict:</b> PASS	
<b>Date(s):</b> 26-May-19			
<b>Temperature:</b> 26 °C	<b>Relative Humidity:</b> 47 %	<b>Air Pressure:</b> 1015 hPa	<b>Power:</b> 3.6 VDC
<b>Remarks:</b>			

**Plot 7.1.10 Radiated emission measurements at the low fundamental frequency with GFSK 50 kbps**

TEST SITE: Semi anechoic chamber  
TEST DISTANCE: 3 m  
ANTENNA POLARIZATION: Vertical and horizontal

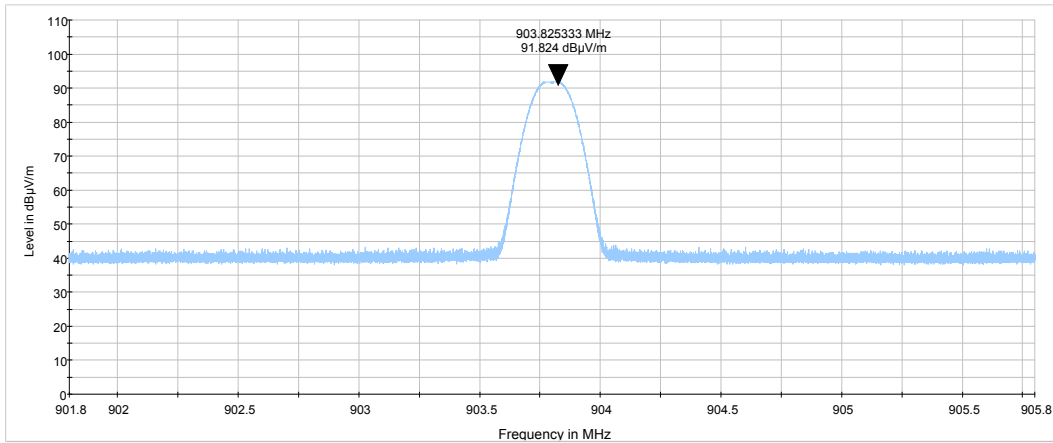

**Plot 7.1.11 Radiated emission measurements at the mid fundamental frequency with GFSK 50 kbps**

TEST SITE: Semi anechoic chamber  
TEST DISTANCE: 3 m  
ANTENNA POLARIZATION: Vertical and horizontal

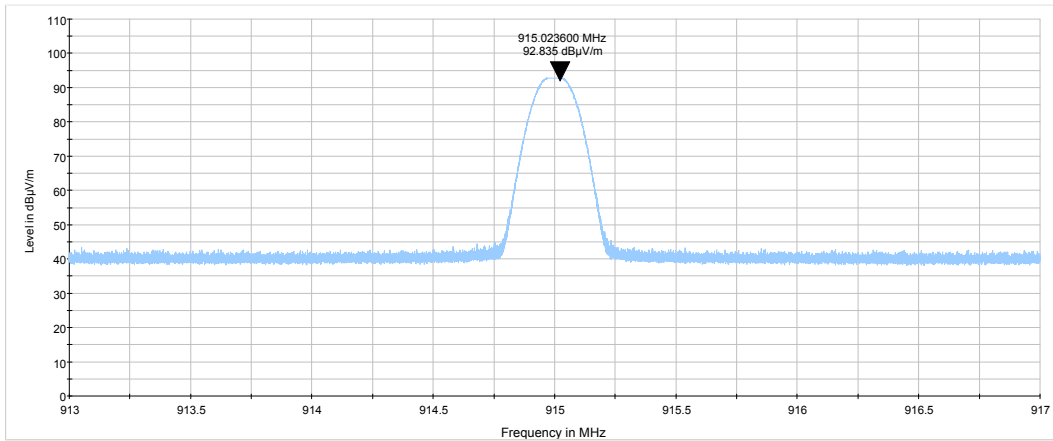



<b>Test specification: Section 15.249(a)(d)/RSS-210, section B.10, Field strength of emissions</b>			
<b>Test procedure:</b> ANSI C63.10, Section 6.5, 6.6			
<b>Test mode:</b> Compliance		<b>Verdict:</b> PASS	
<b>Date(s):</b> 26-May-19			
<b>Temperature:</b> 26 °C	<b>Relative Humidity:</b> 47 %	<b>Air Pressure:</b> 1015 hPa	<b>Power:</b> 3.6 VDC
<b>Remarks:</b>			

**Plot 7.1.12 Radiated emission measurements at the high fundamental frequency with GFSK 50 kbps**

TEST SITE: Semi anechoic chamber  
TEST DISTANCE: 3 m  
ANTENNA POLARIZATION: Vertical and horizontal

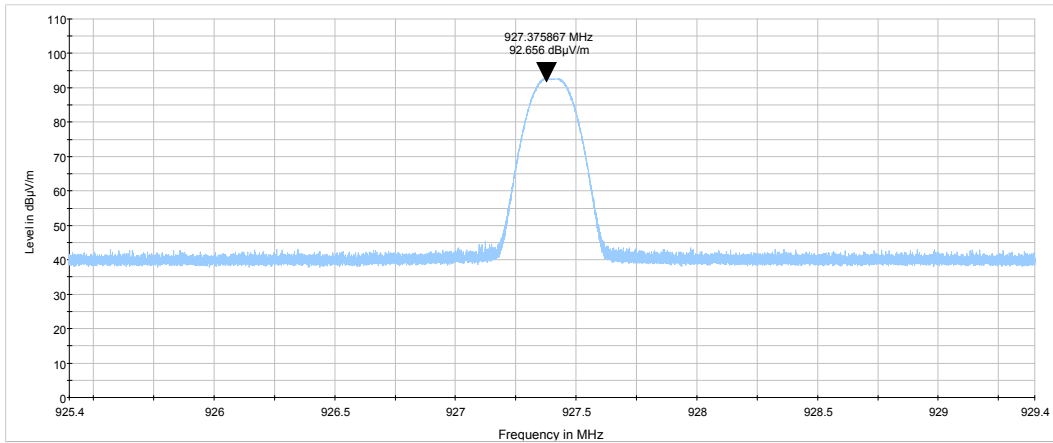

**Plot 7.1.13 Radiated emission measurements from 9 kHz to 30 MHz at the low carrier frequency**

TEST SITE: Semi anechoic chamber  
TEST DISTANCE: 3 m  
ANTENNA POLARIZATION: Vertical

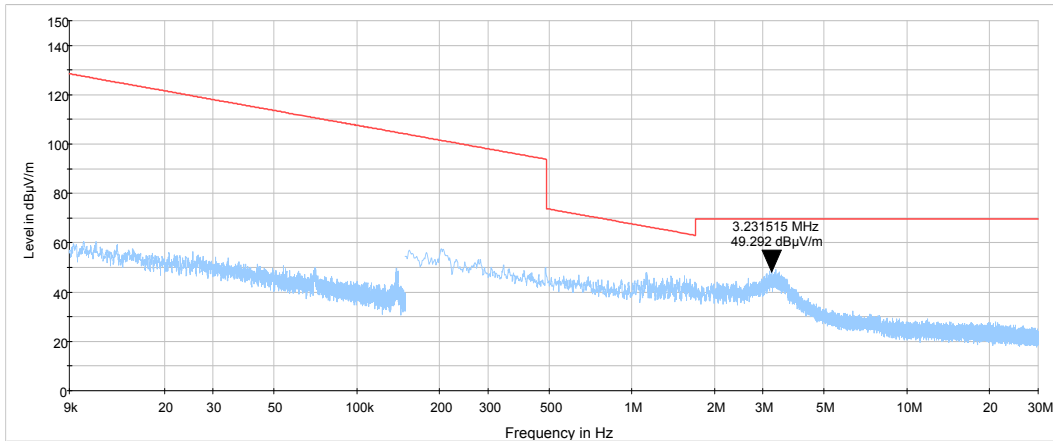



HERMON LABORATORIES

<b>Test specification: Section 15.249(a)(d)/RSS-210, section B.10, Field strength of emissions</b>			
<b>Test procedure:</b> ANSI C63.10, Section 6.5, 6.6			
<b>Test mode:</b> Compliance		<b>Verdict:</b> PASS	
<b>Date(s):</b> 26-May-19			
<b>Temperature:</b> 26 °C	<b>Relative Humidity:</b> 47 %	<b>Air Pressure:</b> 1015 hPa	<b>Power:</b> 3.6 VDC
<b>Remarks:</b>			

**Plot 7.1.14 Radiated emission measurements from 9 kHz to 30 MHz at the mid carrier frequency**

TEST SITE: Semi anechoic chamber  
TEST DISTANCE: 3 m  
ANTENNA POLARIZATION: Vertical

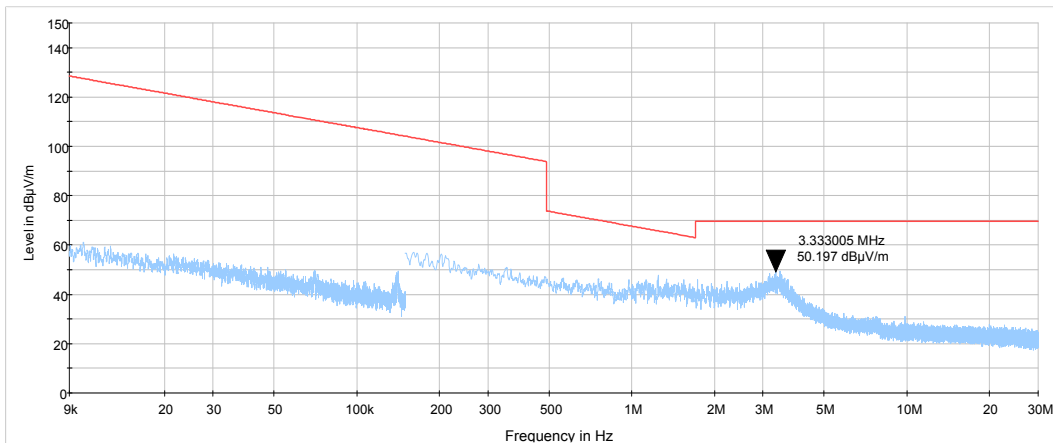

**Plot 7.1.15 Radiated emission measurements from 9 kHz to 30 MHz at the high carrier frequency**

TEST SITE: Semi anechoic chamber  
TEST DISTANCE: 3 m  
ANTENNA POLARIZATION: Vertical

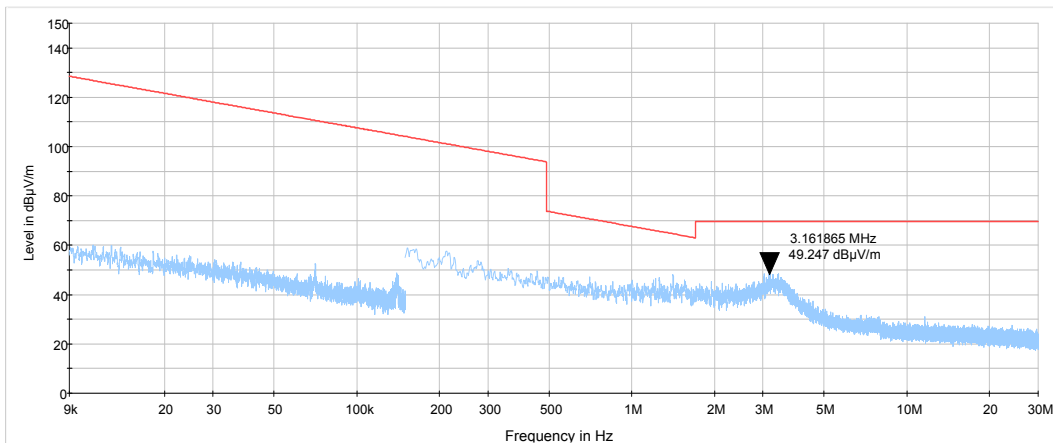



HERMON LABORATORIES

<b>Test specification: Section 15.249(a)(d)/RSS-210, section B.10, Field strength of emissions</b>			
<b>Test procedure: ANSI C63.10, Section 6.5, 6.6</b>			
<b>Test mode: Compliance</b>		<b>Verdict: PASS</b>	
<b>Date(s): 26-May-19</b>			
<b>Temperature: 26 °C</b>	<b>Relative Humidity: 47 %</b>	<b>Air Pressure: 1015 hPa</b>	<b>Power: 3.6 VDC</b>
<b>Remarks:</b>			

**Plot 7.1.16 Radiated emission measurements from 30 to 1000 MHz at the low carrier frequency**

TEST SITE: Semi anechoic chamber  
TEST DISTANCE: 3 m  
ANTENNA POLARIZATION: Vertical and Horizontal

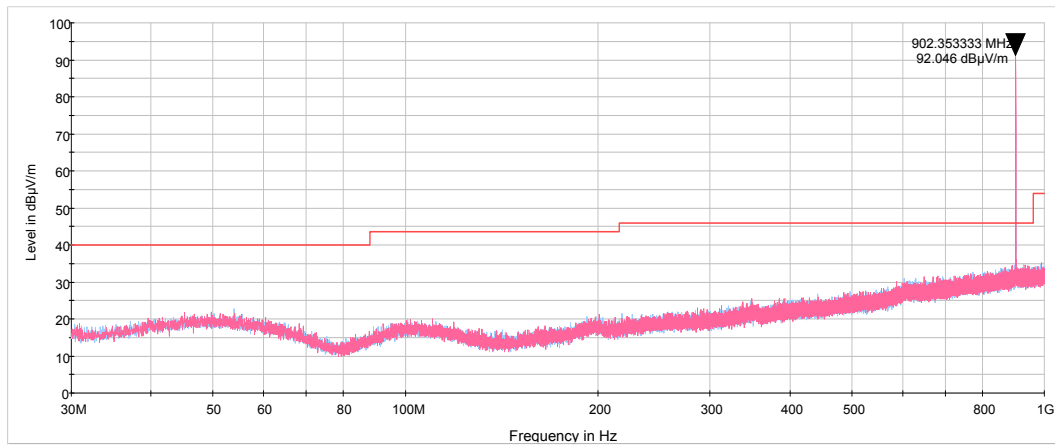

**Plot 7.1.17 Radiated emission measurements from 30 to 1000 MHz at the mid carrier frequency**

TEST SITE: Semi anechoic chamber  
TEST DISTANCE: 3 m  
ANTENNA POLARIZATION: Vertical and Horizontal

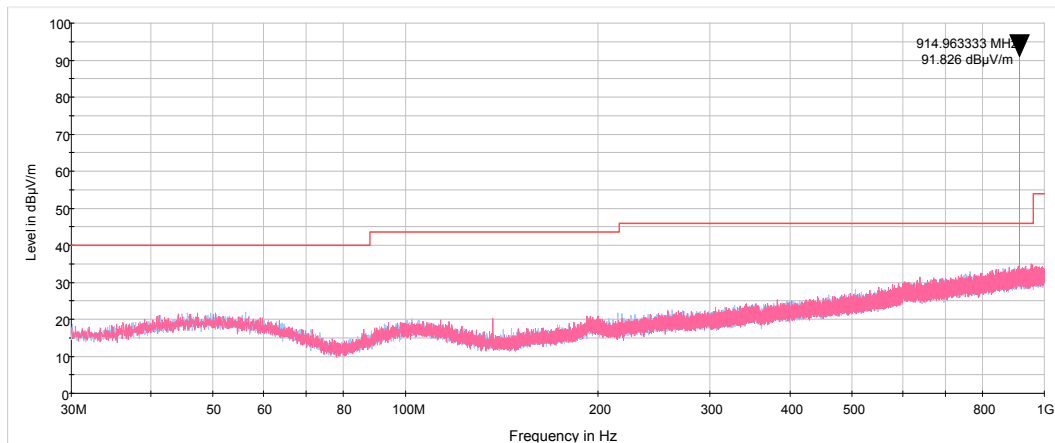



<b>Test specification:</b> Section 15.249(a)(d)/RSS-210, section B.10, Field strength of emissions			
<b>Test procedure:</b> ANSI C63.10, Section 6.5, 6.6			
<b>Test mode:</b> Compliance		<b>Verdict:</b> PASS	
<b>Date(s):</b> 26-May-19			
<b>Temperature:</b> 26 °C	<b>Relative Humidity:</b> 47 %	<b>Air Pressure:</b> 1015 hPa	<b>Power:</b> 3.6 VDC
<b>Remarks:</b>			

**Plot 7.1.18 Radiated emission measurements from 30 to 1000 MHz at the high carrier frequency**

TEST SITE: Semi anechoic chamber  
TEST DISTANCE: 3 m  
ANTENNA POLARIZATION: Vertical and Horizontal

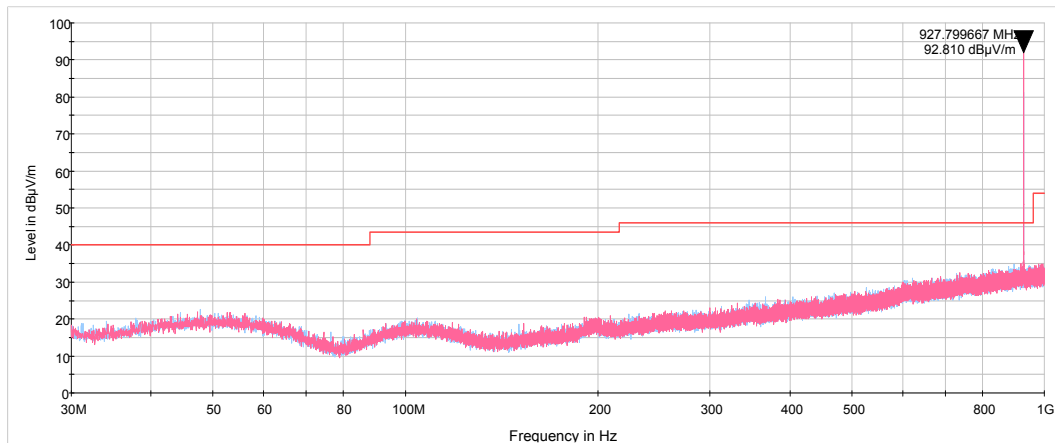

**Plot 7.1.19 Radiated emission measurements from 1 – 9.5 GHz at the low carrier frequency**

TEST SITE: Semi anechoic chamber  
TEST DISTANCE: 3 m  
ANTENNA POLARIZATION: Vertical and Horizontal

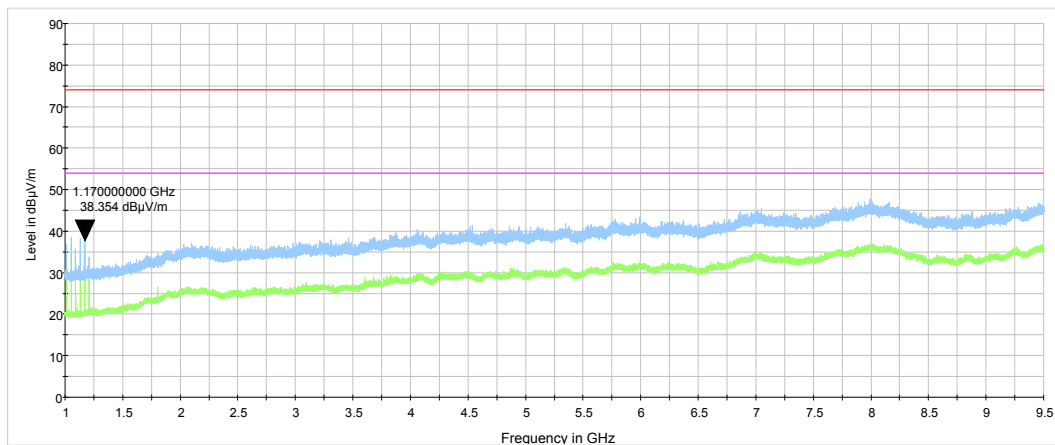



HERMON LABORATORIES

<b>Test specification: Section 15.249(a)(d)/RSS-210, section B.10, Field strength of emissions</b>			
<b>Test procedure:</b> ANSI C63.10, Section 6.5, 6.6			
<b>Test mode:</b> Compliance		<b>Verdict:</b> PASS	
<b>Date(s):</b> 26-May-19			
<b>Temperature:</b> 26 °C	<b>Relative Humidity:</b> 47 %	<b>Air Pressure:</b> 1015 hPa	<b>Power:</b> 3.6 VDC
<b>Remarks:</b>			

**Plot 7.1.20 Radiated emission measurements from 1 – 9.5 GHz at the mid carrier frequency**

TEST SITE: Semi anechoic chamber  
TEST DISTANCE: 3 m  
ANTENNA POLARIZATION: Vertical and Horizontal

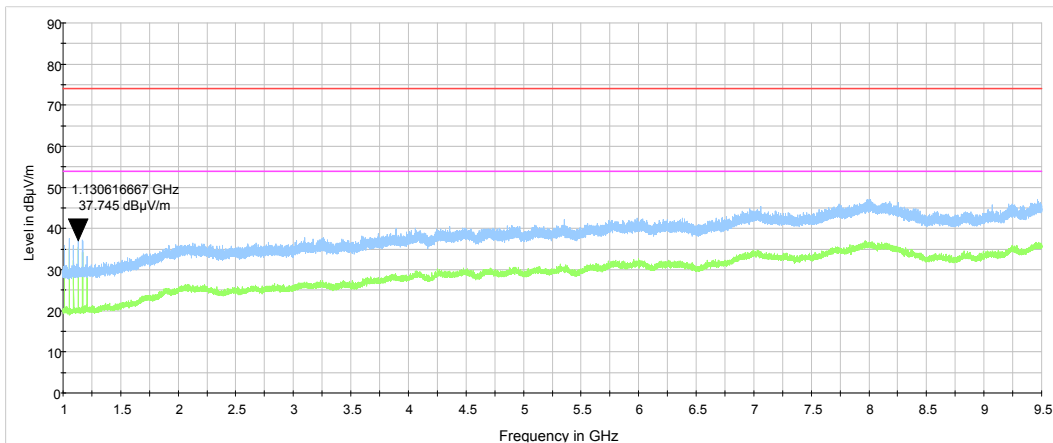

**Plot 7.1.21 Radiated emission measurements from 1 – 9.5 GHz at the high carrier frequency**

TEST SITE: Semi anechoic chamber  
TEST DISTANCE: 3 m  
ANTENNA POLARIZATION: Vertical and Horizontal

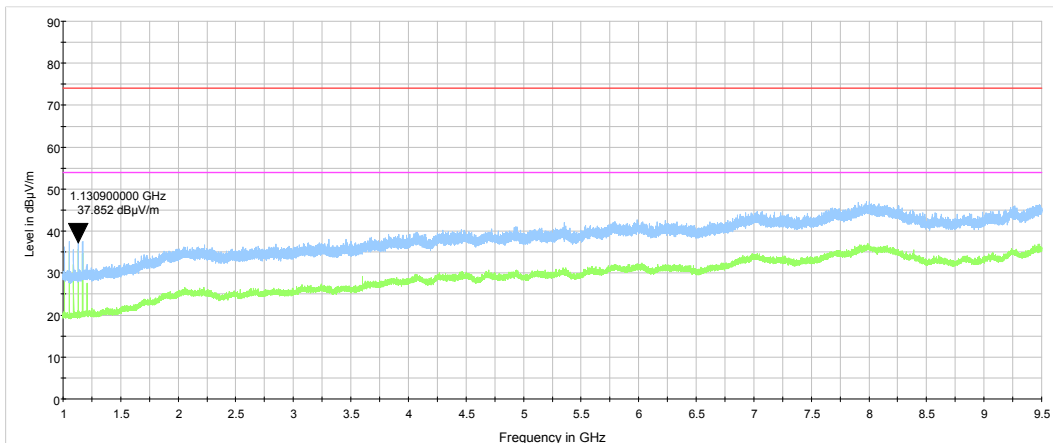



<b>Test specification: Section 15.215(c), Occupied bandwidth</b>			
<b>Test procedure:</b> ANSI C63.10, Section 6.9.2			
<b>Test mode:</b> Compliance		<b>Verdict:</b> PASS	
<b>Date(s):</b> 30-May-19			
<b>Temperature:</b> 26 °C	<b>Relative Humidity:</b> 45 %	<b>Air Pressure:</b> 1009 hPa	<b>Power:</b> 3.6 VDC
<b>Remarks:</b>			

## 7.2 Occupied bandwidth test

### 7.2.1 General

This test was performed to verify that the 20 dB bandwidth of the emissions was contained within the standard specified frequency band according to FCC §15.215 requirements. Specification test limits are given in Table 7.2.1.

**Table 7.2.1 Occupied bandwidth limits FCC 15.249**

Assigned frequency, MHz	Modulation envelope reference points*, dBc
<b>902 - 928</b>	20.0
2400 – 2483.5	
5725 – 5875	
24000 – 24250	

\*- Modulation envelope reference points provided in terms of attenuation below modulated carrier.

**Table 7.2.2 Occupied bandwidth limits RSS-210**

Assigned frequency, MHz	Modulation envelope reference points*, %
<b>902 - 928</b>	99
2400 – 2483.5	
5725 – 5875	
24000 – 24250	

\*- Modulation envelope reference points provided in terms of attenuation below modulated carrier.

### 7.2.2 Test procedure

**7.2.2.1** The EUT was set up as shown in Figure 7.2.1, energized and its proper operation was checked.

**7.2.2.2** The spectrum analyzer sweep time and bandwidth were set to capture all major modulation sidebands of emission and sweep time was set sufficiently slow to ensure peak measurements. Spectrum analyzer was set in peak hold mode and time sufficient for trace stabilization was allowed.

**7.2.2.3** The peak of emission was measured. The transmitter occupied bandwidth was measured with spectrum analyzer as frequency delta between reference points on modulation envelope and provided in Table 7.2.2 and associated plot.

**Figure 7.2.1 Occupied bandwidth test setup**





<b>Test specification: Section 15.215(c), Occupied bandwidth</b>			
<b>Test procedure:</b> ANSI C63.10, Section 6.9.2			
<b>Test mode:</b> Compliance		<b>Verdict: PASS</b>	
<b>Date(s):</b> 30-May-19			
<b>Temperature:</b> 26 °C	<b>Relative Humidity:</b> 45 %	<b>Air Pressure:</b> 1009 hPa	<b>Power:</b> 3.6 VDC
<b>Remarks:</b>			

Table 7.2.3 Occupied bandwidth test results RSS-210 & FCC 15.249

ASSIGNED FREQUENCY BAND 902.0 – 928.0 MHz  
DETECTOR USED: Peak hold  
MODULATION: 2FSK  
BIT RATE: 9.6 kbps  
MODULATING SIGNAL: enable  
RESOLUTION BANDWIDTH: 1 kHz  
VIDEO BANDWIDTH: 3 kHz

Carrier frequency, MHz	99% Occupied bandwidth, kHz	20 dBc OBW, kHz	Verdict
902.3	21.094	22.215	Pass
915.0	21.048	22.055	Pass
927.8	21.054	22.233	Pass

MODULATION: 2FSK  
BIT RATE: 19.2 kbps  
MODULATING SIGNAL: enable  
RESOLUTION BANDWIDTH: 1 kHz  
VIDEO BANDWIDTH: 3 kHz

Carrier frequency, MHz	99% Occupied bandwidth, kHz	20 dBc OBW, kHz	Verdict
902.4	42.166	41.901	Pass
915.0	42.522	43.434	Pass
927.6	42.204	42.203	Pass

MODULATION: 2FSK  
BIT RATE: 38.4 kbps  
MODULATING SIGNAL: enable  
RESOLUTION BANDWIDTH: 3 kHz  
VIDEO BANDWIDTH: 10 kHz

Carrier frequency, MHz	99% Occupied bandwidth, kHz	20 dBc OBW, kHz	Verdict
902.4	85.022	88.193	Pass
915.0	85.718	89.546	Pass
927.6	85.312	88.649	Pass





HERMON LABORATORIES

<b>Test specification: Section 15.215(c), Occupied bandwidth</b>			
<b>Test procedure:</b> ANSI C63.10, Section 6.9.2			
<b>Test mode:</b> Compliance		<b>Verdict: PASS</b>	
<b>Date(s):</b> 30-May-19			
<b>Temperature:</b> 26 °C	<b>Relative Humidity:</b> 45 %	<b>Air Pressure:</b> 1009 hPa	<b>Power:</b> 3.6 VDC
<b>Remarks:</b>			

MODULATION: GFSK  
 BIT RATE: 50.0 kbps  
 MODULATING SIGNAL: enable  
 RESOLUTION BANDWIDTH: 3 kHz  
 VIDEO BANDWIDTH: 10 kHz

Carrier frequency, MHz	99% Occupied bandwidth, kHz	20 dBc OBW, kHz	Verdict
903.8	85.618	91.225	Pass
915.0	85.371	91.353	Pass
927.4	85.533	96.481	Pass

**Reference numbers of test equipment used**

HL 0337	HL 2909	HL 4136					
---------	---------	---------	--	--	--	--	--

Full description is given in Appendix A.

**Plot 7.2.1 The 20 dB bandwidth test result at low frequency with 2FSK 9.6 kbps**

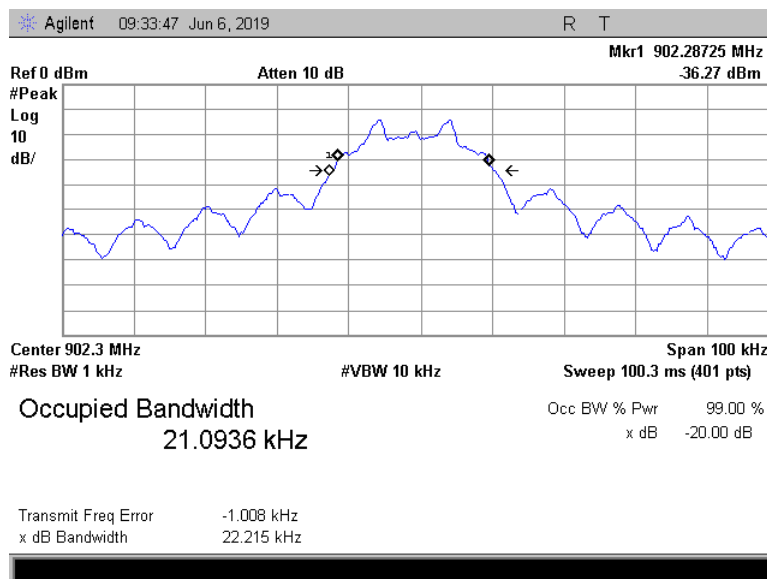



HERMON LABORATORIES

<b>Test specification: Section 15.215(c), Occupied bandwidth</b>			
<b>Test procedure:</b> ANSI C63.10, Section 6.9.2			
<b>Test mode:</b> Compliance		<b>Verdict: PASS</b>	
<b>Date(s):</b> 30-May-19			
<b>Temperature:</b> 26 °C	<b>Relative Humidity:</b> 45 %	<b>Air Pressure:</b> 1009 hPa	<b>Power:</b> 3.6 VDC
<b>Remarks:</b>			

Plot 7.2.2 The 20 dB bandwidth test result at low frequency with 2FSK 19.2 kbps

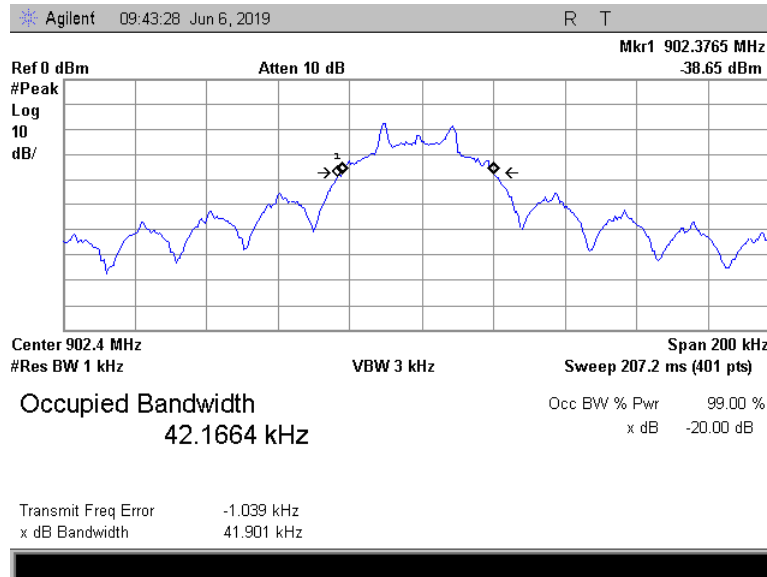

Plot 7.2.3 The 20 dB bandwidth test result at low frequency with 2FSK 38.4 kbps

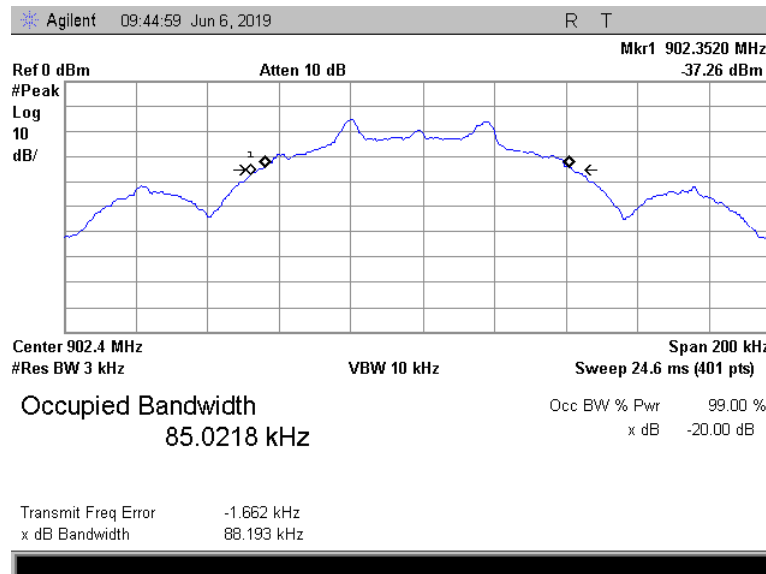



HERMON LABORATORIES

<b>Test specification: Section 15.215(c), Occupied bandwidth</b>			
<b>Test procedure:</b> ANSI C63.10, Section 6.9.2			
<b>Test mode:</b> Compliance		<b>Verdict: PASS</b>	
<b>Date(s):</b> 30-May-19			
<b>Temperature:</b> 26 °C	<b>Relative Humidity:</b> 45 %	<b>Air Pressure:</b> 1009 hPa	<b>Power:</b> 3.6 VDC
<b>Remarks:</b>			

Plot 7.2.4 The 20 dB bandwidth test result at low frequency with QPSK 50.0 kbps

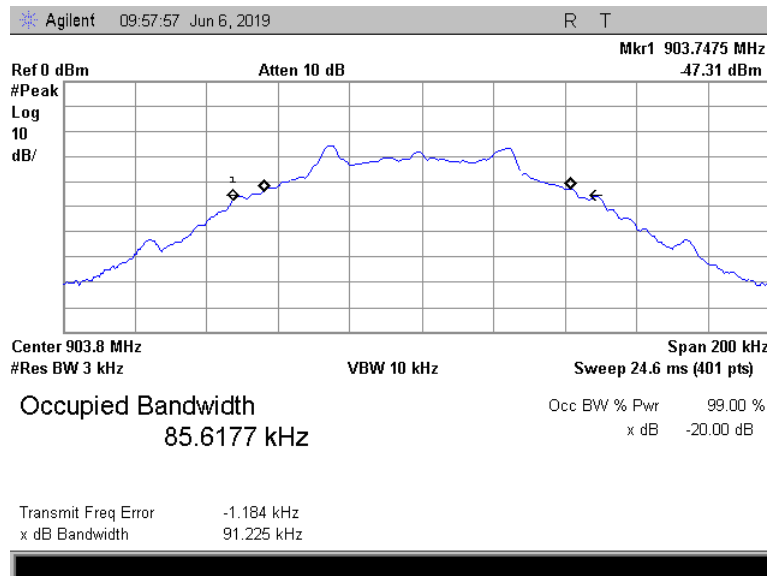

Plot 7.2.5 The 20 dB bandwidth test result at mid frequency with 2FSK 9.6 kbps

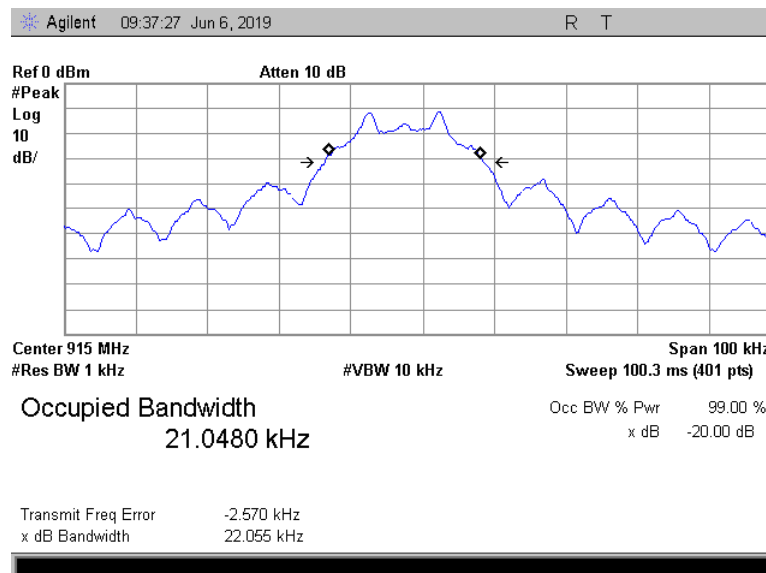



HERMON LABORATORIES

<b>Test specification: Section 15.215(c), Occupied bandwidth</b>			
<b>Test procedure:</b> ANSI C63.10, Section 6.9.2			
<b>Test mode:</b> Compliance		<b>Verdict: PASS</b>	
<b>Date(s):</b> 30-May-19			
<b>Temperature:</b> 26 °C	<b>Relative Humidity:</b> 45 %	<b>Air Pressure:</b> 1009 hPa	<b>Power:</b> 3.6 VDC
<b>Remarks:</b>			

Plot 7.2.6 The 20 dB bandwidth test result at mid frequency with 2FSK 19.2 kbps

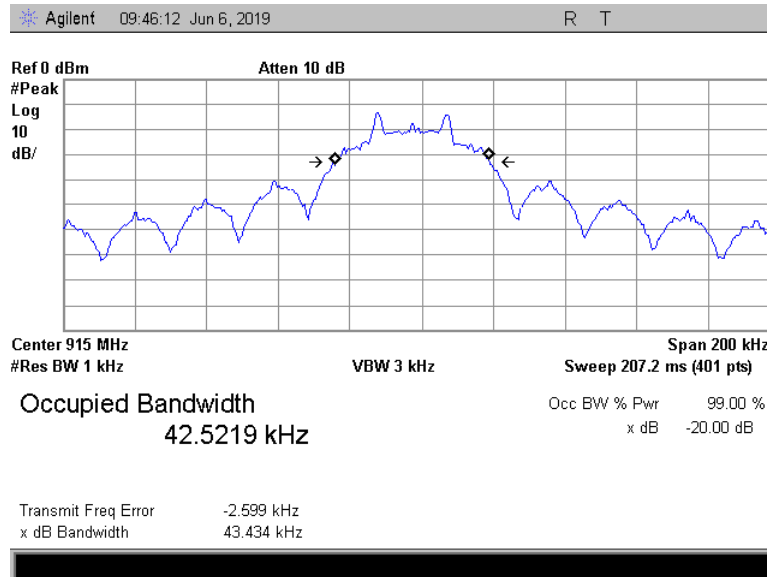

Plot 7.2.7 The 20 dB bandwidth test result at mid frequency with 2FSK 38.4 kbps

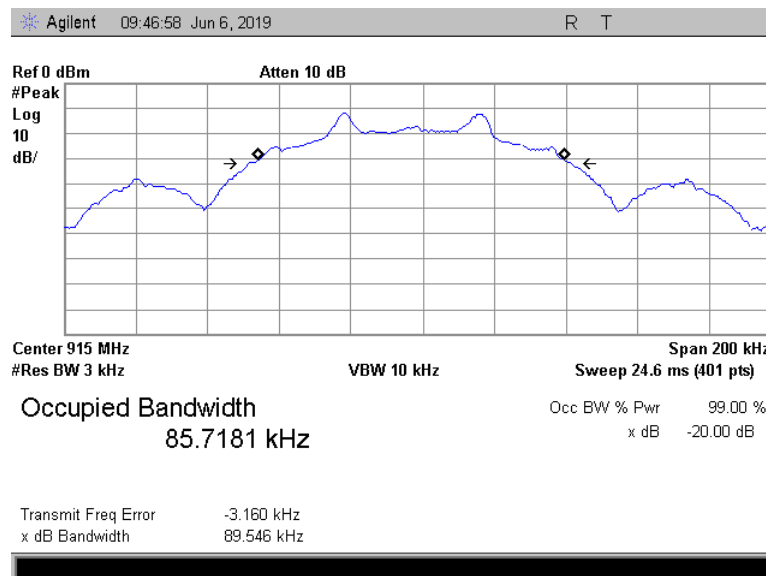



<b>Test specification: Section 15.215(c), Occupied bandwidth</b>			
<b>Test procedure:</b> ANSI C63.10, Section 6.9.2			
<b>Test mode:</b> Compliance		<b>Verdict: PASS</b>	
<b>Date(s):</b> 30-May-19			
<b>Temperature:</b> 26 °C	<b>Relative Humidity:</b> 45 %	<b>Air Pressure:</b> 1009 hPa	<b>Power:</b> 3.6 VDC
<b>Remarks:</b>			

Plot 7.2.8 The 20 dB bandwidth test result at mid frequency with QPSK 50.0 kbps

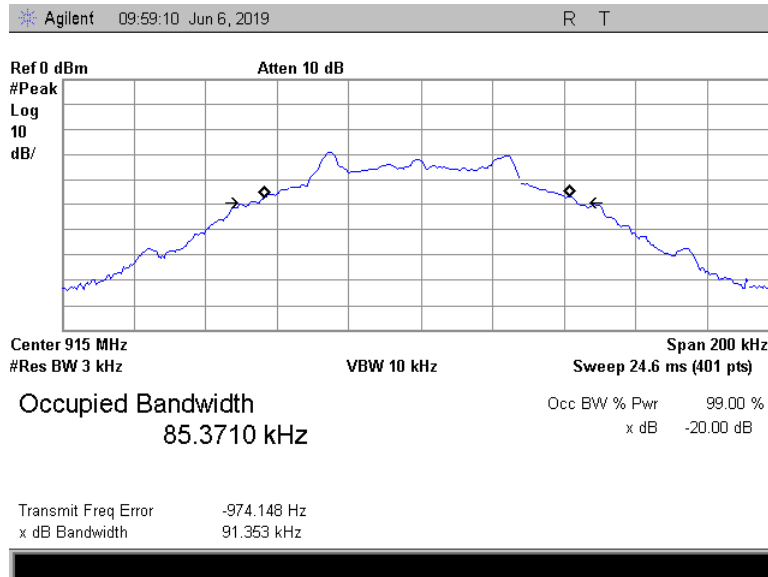

Plot 7.2.9 The 20 dB bandwidth test result at high frequency with 2FSK 9.6 kbps

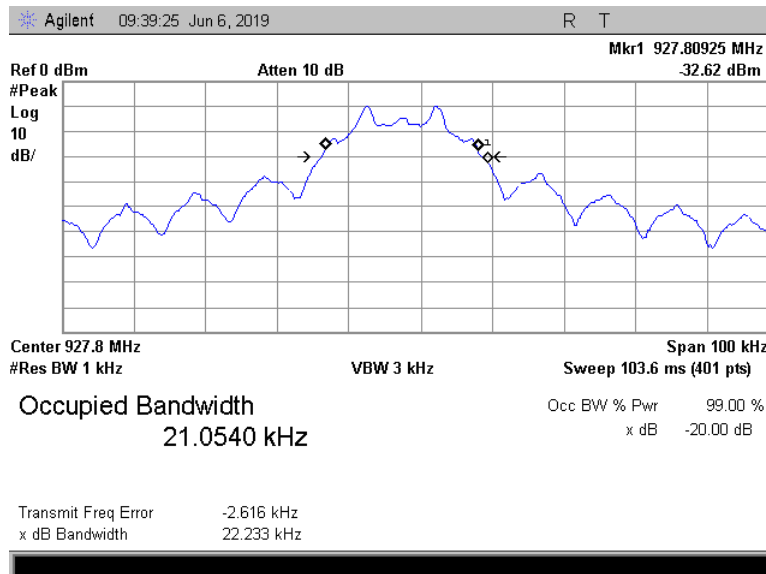



HERMON LABORATORIES

<b>Test specification: Section 15.215(c), Occupied bandwidth</b>			
<b>Test procedure:</b> ANSI C63.10, Section 6.9.2			
<b>Test mode:</b> Compliance		<b>Verdict: PASS</b>	
<b>Date(s):</b> 30-May-19			
<b>Temperature:</b> 26 °C	<b>Relative Humidity:</b> 45 %	<b>Air Pressure:</b> 1009 hPa	<b>Power:</b> 3.6 VDC
<b>Remarks:</b>			

Plot 7.2.10 The 20 dB bandwidth test result at high frequency with 2FSK 19.2 kbps

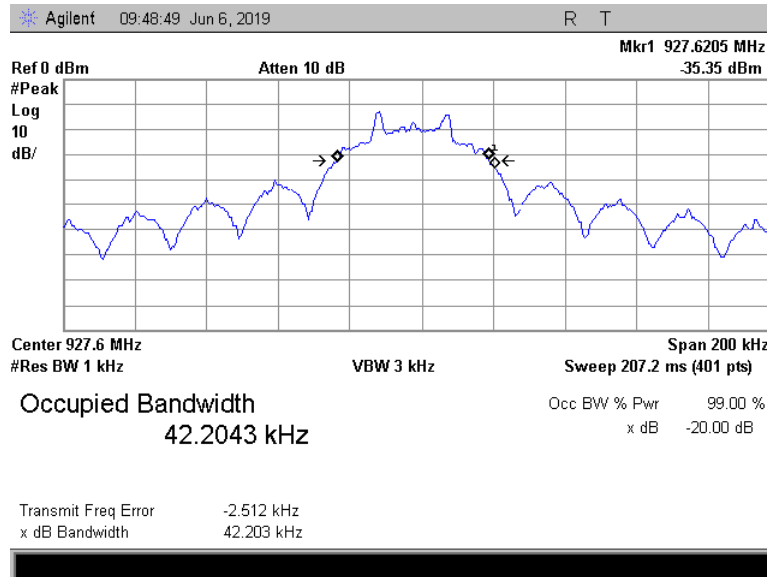

Plot 7.2.11 The 20 dB bandwidth test result at high frequency with 2FSK 38.4 kbps

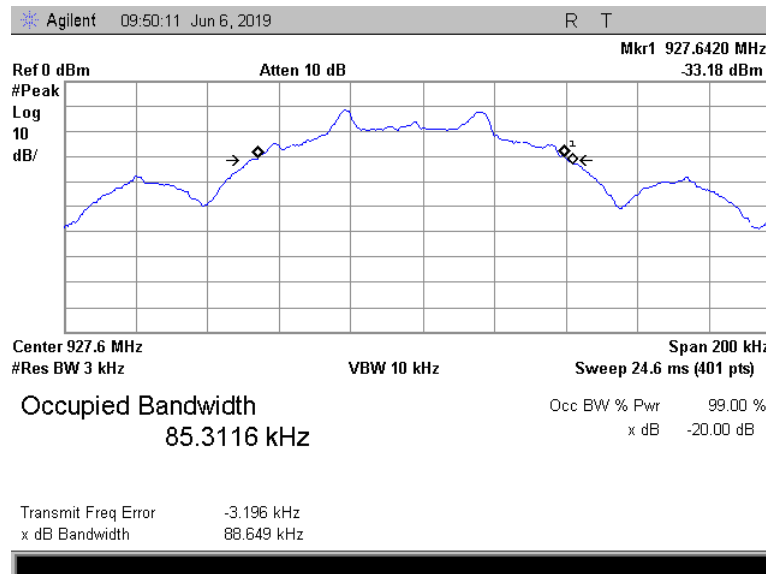



HERMON LABORATORIES

<b>Test specification: Section 15.215(c), Occupied bandwidth</b>			
Test procedure: ANSI C63.10, Section 6.9.2			
Test mode: Compliance		<b>Verdict: PASS</b>	
Date(s): 30-May-19			
Temperature: 26 °C	Relative Humidity: 45 %	Air Pressure: 1009 hPa	Power: 3.6 VDC
Remarks:			

Plot 7.2.12 The 20 dB bandwidth test result at high frequency with QPSK 50.0 kbps

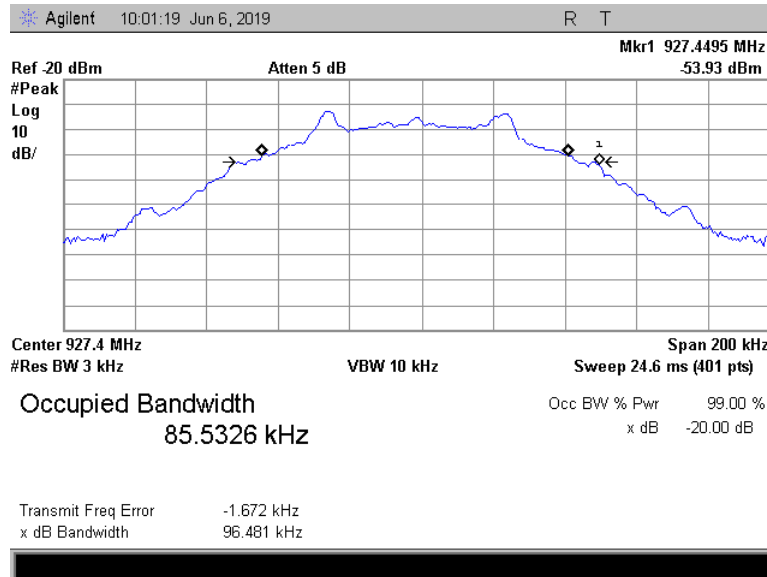



<b>Test specification: Section 15.249(d)/RSS-210, section C.4, Band edge emissions</b>			
<b>Test procedure:</b> ANSI C63.10, Section 6.10			
<b>Test mode:</b> Compliance		<b>Verdict: PASS</b>	
<b>Date(s):</b> 29-May-19			
<b>Temperature:</b> 25 °C	<b>Relative Humidity:</b> 46 %	<b>Air Pressure:</b> 1012 hPa	<b>Power:</b> 3.6 VDC
<b>Remarks:</b>			

### 7.3 Band edge emission

#### 7.3.1 General

This test was performed to verify the EUT band edge emission including all associated side bands was attenuated at least 50 dB below the unmodulated carrier level or below the general spurious emission limit. Specification test limits are given in Table 7.3.1.

Table 7.3.1 Band edge emission limits

Frequency band, MHz	Field strength limit at 3 m, dBµV/m		Attenuation below carrier, dBc
	Peak	QP	
902.000 - 928.000	NA	46.0	50

#### 7.3.2 Test procedure

7.3.2.1 The EUT was set up as shown in Figure 7.3.1, energized and the performance check was conducted.

7.3.2.2 The spectrum analyzer frequency span was set to capture all major modulation sidebands of emission and sweep time was set sufficiently slow to ensure peak measurements. Spectrum analyzer was set in peak hold mode and time sufficient for trace stabilization was allowed.

7.3.2.3 The frequency of modulation envelope points beyond which power level drops below the band edge emission limit was measured.

7.3.2.4 The test results were recorded in Table 7.3.2 and shown in the associated plots.

Figure 7.3.1 Band edge emission measurement set up

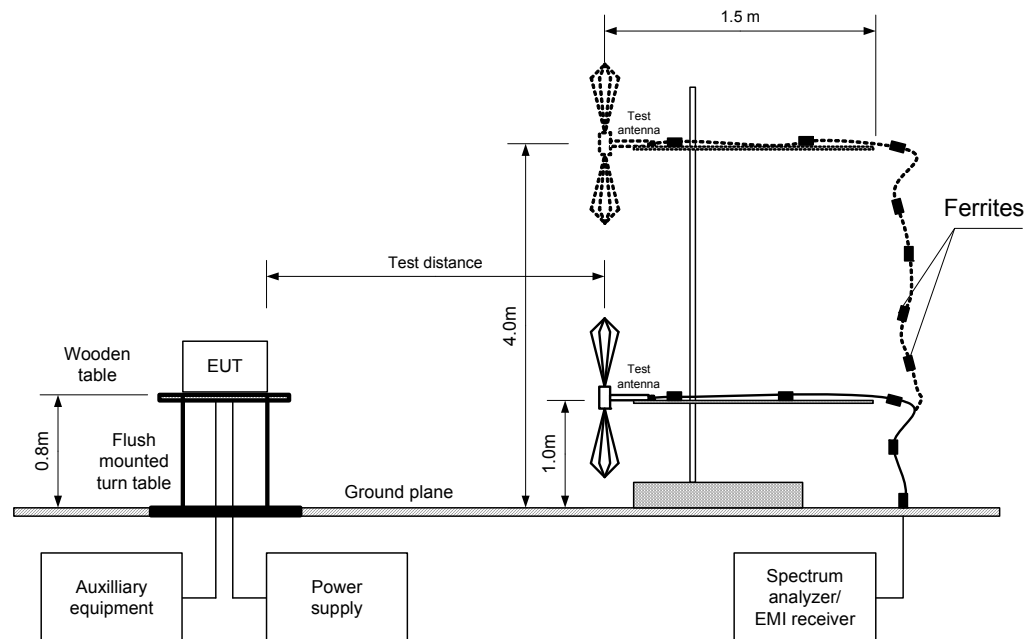





<b>Test specification:</b> Section 15.249(d)/RSS-210, section C.4, Band edge emissions			
<b>Test procedure:</b> ANSI C63.10, Section 6.10			
<b>Test mode:</b> Compliance		<b>Verdict:</b> PASS	
<b>Date(s):</b> 29-May-19			
<b>Temperature:</b> 25 °C	<b>Relative Humidity:</b> 46 %	<b>Air Pressure:</b> 1012 hPa	<b>Power:</b> 3.6 VDC
<b>Remarks:</b>			

**Table 7.3.2 Band edge emission test results**

OPERATING FREQUENCY RANGE: 902.0 – 928.0 MHz  
 DETECTOR USED: Peak hold  
 RESOLUTION BANDWIDTH: 100 kHz  
 VIDEO BANDWIDTH: 300 kHz  
 MODULATING SIGNAL: PRBS  
 TRANSMITTER OUTPUT POWER SETTINGS: Maximum

MODULATION: 2FSK  
 BIT RATE: 9.6 kbps  
 LOW CARRIER FREQUENCY: 902.3 MHz  
 HIGH CARRIER FREQUENCY: 927.8 MHz

Modulation envelope		Measured peak emission, dBµV/m	Measured QP emission, dBµV/m	QP limit, dBµV/m	Margin, dB *	Verdict
Edge	Frequency, MHz					
Low	901.996	46.60	39.44	46.0	-6.56	Pass
High	928.004	52.13	45.97	46.0	-0.03	Pass

MODULATION: 2FSK  
 BIT RATE: 38.4 kbps  
 LOW CARRIER FREQUENCY: 902.4 MHz  
 HIGH CARRIER FREQUENCY: 927.6 MHz

Modulation envelope		Measured peak emission, dBµV/m	Measured QP emission, dBµV/m	QP limit, dBµV/m	Margin, dB *	Verdict
Edge	Frequency, MHz					
Low	901.999	46.59	41.57	46.0	-4.43	Pass
High	928.005	45.77	40.38	46.0	-5.62	Pass

MODULATION: GFSK  
 BIT RATE: 50 kbps  
 LOW CARRIER FREQUENCY: 903.8 MHz  
 HIGH CARRIER FREQUENCY: 927.4 MHz

Modulation envelope		Measured peak emission, dBµV/m	Measured QP emission, dBµV/m	QP limit, dBµV/m	Margin, dB *	Verdict
Edge	Frequency, MHz					
Low	No emission were found					Pass
High	928.076	37.46	30.57	46.0	-15.43	Pass

\* - Margin = measured value– limit

The test shows compliance with 15.249(d) requirements.

**Reference numbers of test equipment used**

HL 3903	HL 4360	HL 5288	HL 5405			
---------	---------	---------	---------	--	--	--

Full description is given in Appendix A.



<b>Test specification:</b> Section 15.249(d)/RSS-210, section C.4, Band edge emissions			
<b>Test procedure:</b> ANSI C63.10, Section 6.10			
<b>Test mode:</b> Compliance		<b>Verdict:</b> PASS	
<b>Date(s):</b> 29-May-19			
<b>Temperature:</b> 25 °C	<b>Relative Humidity:</b> 46 %	<b>Air Pressure:</b> 1012 hPa	<b>Power:</b> 3.6 VDC
<b>Remarks:</b>			

**Plot 7.3.1 Low band edge emission test result**

TEST SITE: Semi anechoic chamber  
 TEST DISTANCE: 3 m  
 ANTENNA POLARIZATION: Vertical and Horizontal  
 MODULATION: 2FSK  
 BIT RATE: 9.6 kbps

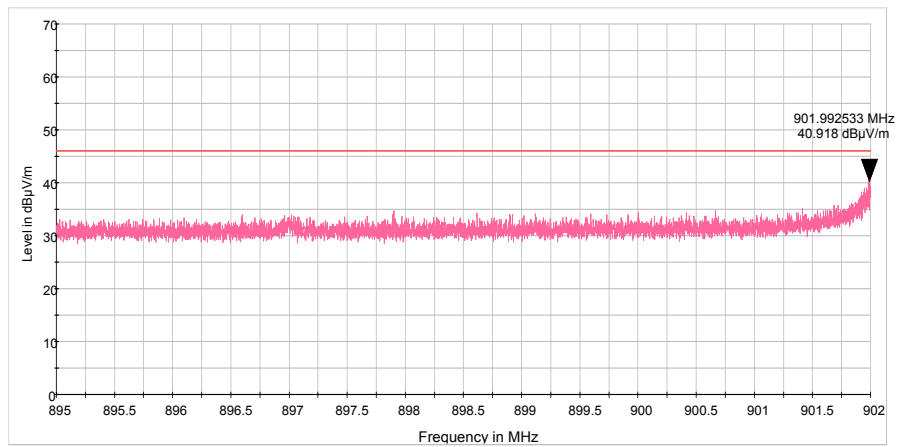

**Plot 7.3.2 High band edge emission test result**

TEST SITE: Semi anechoic chamber  
 TEST DISTANCE: 3 m  
 ANTENNA POLARIZATION: Vertical and Horizontal  
 MODULATION: 2FSK  
 BIT RATE: 9.6 kbps

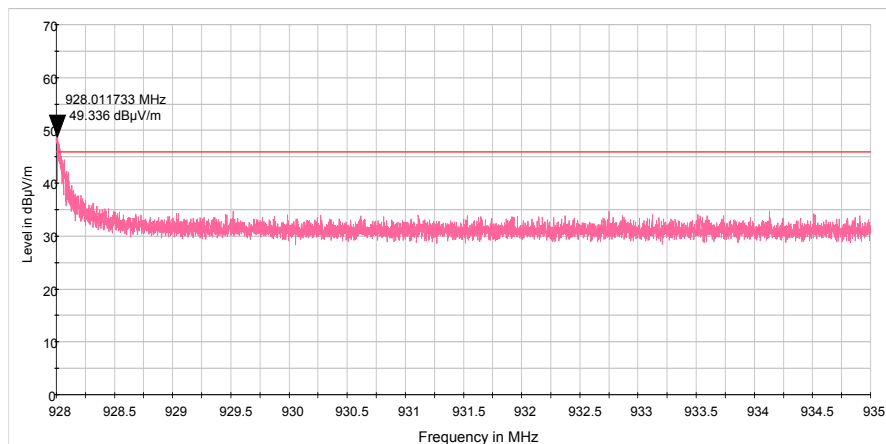



<b>Test specification:</b> Section 15.249(d)/RSS-210, section C.4, Band edge emissions			
<b>Test procedure:</b> ANSI C63.10, Section 6.10			
<b>Test mode:</b> Compliance		<b>Verdict:</b> PASS	
<b>Date(s):</b> 29-May-19			
<b>Temperature:</b> 25 °C	<b>Relative Humidity:</b> 46 %	<b>Air Pressure:</b> 1012 hPa	<b>Power:</b> 3.6 VDC
<b>Remarks:</b>			

**Plot 7.3.3 Low band edge emission test result**

TEST SITE: Semi anechoic chamber  
 TEST DISTANCE: 3 m  
 ANTENNA POLARIZATION: Vertical and Horizontal  
 MODULATION: 2FSK  
 BIT RATE: 38.4 kbps

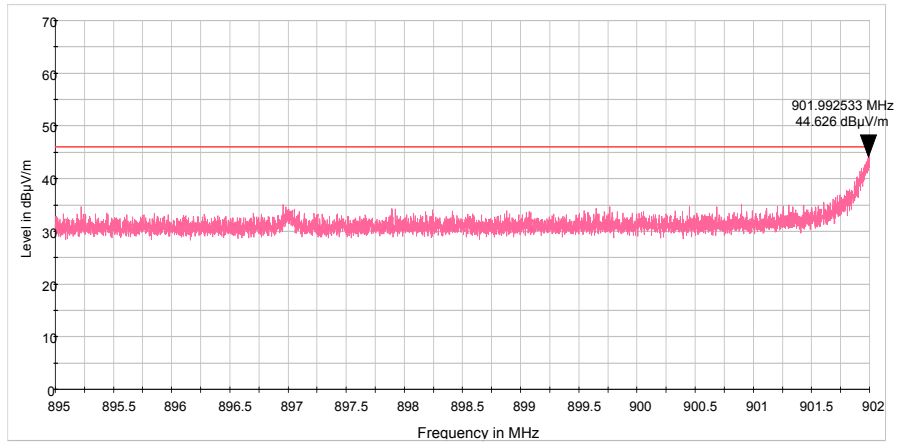

**Plot 7.3.4 High band edge emission test result**

TEST SITE: Semi anechoic chamber  
 TEST DISTANCE: 3 m  
 ANTENNA POLARIZATION: Vertical and Horizontal  
 MODULATION: 2FSK  
 BIT RATE: 38.4 kbps

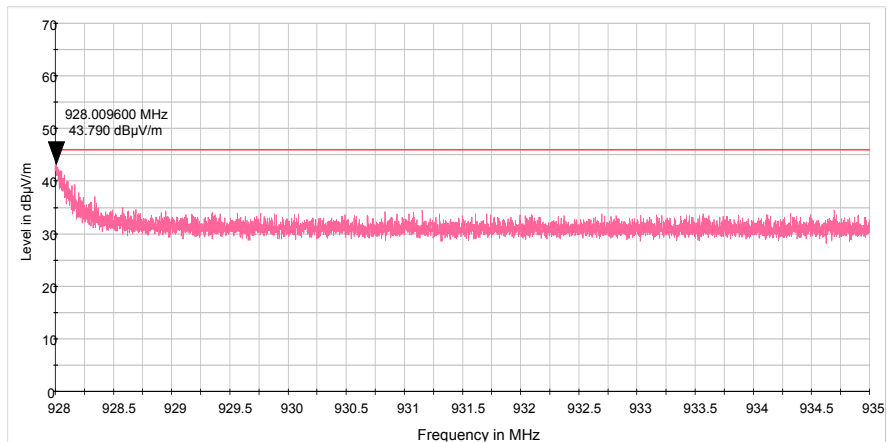



<b>Test specification:</b> Section 15.249(d)/RSS-210, section C.4, Band edge emissions			
<b>Test procedure:</b> ANSI C63.10, Section 6.10			
<b>Test mode:</b> Compliance		<b>Verdict:</b> PASS	
<b>Date(s):</b> 29-May-19			
<b>Temperature:</b> 25 °C	<b>Relative Humidity:</b> 46 %	<b>Air Pressure:</b> 1012 hPa	<b>Power:</b> 3.6 VDC
<b>Remarks:</b>			

**Plot 7.3.5 Low band edge emission test result**

TEST SITE: Semi anechoic chamber  
TEST DISTANCE: 3 m  
ANTENNA POLARIZATION: Vertical and Horizontal  
MODULATION: GFSK  
BIT RATE: 50 kbps

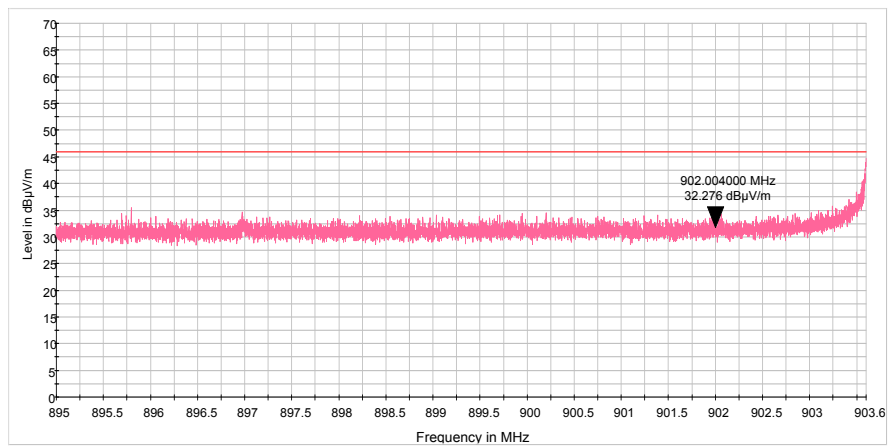

**Plot 7.3.6 High band edge emission test result**

TEST SITE: Semi anechoic chamber  
TEST DISTANCE: 3 m  
ANTENNA POLARIZATION: Vertical and Horizontal  
MODULATION: GFSK  
BIT RATE: 50 kbps

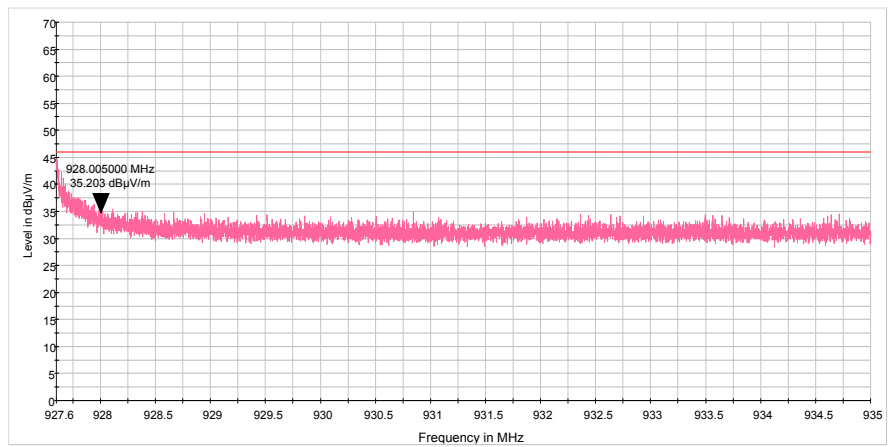



<b>Test specification:</b> Section 15.203, Antenna requirement			
<b>Test procedure:</b> Visual inspection / supplier declaration			
<b>Test mode:</b> Compliance		<b>Verdict:</b> PASS	
<b>Date(s):</b> 10-Jun-19			
<b>Temperature:</b> 25 °C	<b>Relative Humidity:</b> 46 %	<b>Air Pressure:</b> 1008 hPa	<b>Power:</b> 3.6 VDC
<b>Remarks:</b>			

### 7.4 Antenna requirements

The EUT was verified for compliance with antenna requirements. A transmitter shall be designed to ensure that no antenna other than that furnished by the responsible party will be used with the device. It may be either permanently attached or employs a unique antenna connector for every antenna proposed for use with the EUT. This requirement does not apply to professionally installed transmitters.

The rationale for compliance with the above requirements was either visual inspection results or supplier declaration. The summary of results is provided in Table 7.4.1.

Table 7.4.1 Antenna requirements

Requirement	Rationale	Verdict
The transmitter antenna is permanently attached	Visual inspection	Comply
The transmitter employs a unique antenna connector	NA	
The transmitter requires professional installation	NA	



<b>Test specification:</b> Section 15.109/RSS-Gen, section 7.3, ICES-003, Radiated emission			
<b>Test procedure:</b> ANSI C63.4, Sections 11.6 and 12.1.4			
<b>Test mode:</b> Compliance		<b>Verdict:</b> PASS	
<b>Date(s):</b> 28-May-19			
<b>Temperature:</b> 24 °C	<b>Relative Humidity:</b> 48 %	<b>Air Pressure:</b> 1012 hPa	<b>Power:</b> 3.6 VDC
<b>Remarks:</b>			

## 8 Unintentional emission tests according to 47CFR part 15 subpart B

### 8.1 Radiated emission measurements

#### 8.1.1 General

This test was performed to measure radiated emissions from the EUT enclosure. Specification test limits are given in Table 8.1.1.

Table 8.1.1 Radiated emission test limits

Frequency, MHz	Class B limit, dB(μV/m)		Class A limit, dB(μV/m)	
	10 m distance	3 m distance	10 m distance	3 m distance
30 - 88	29.5*	40.0	39.0	49.5*
88 - 216	33.0*	43.5	43.5	54.0*
216 - 960	35.5*	46.0	46.4	56.9*
Above 960	43.5*	54.0	49.5	60.0*

\* The limit for test distance other than specified was calculated using the inverse linear distance extrapolation factor as follows:  $Lim_{S_2} = Lim_{S_1} + 20 \log(S_1/S_2)$ , where  $S_1$  and  $S_2$  – standard defined and test distance respectively in meters.

#### 8.1.2 Test procedure for measurements in semi-anechoic chamber

8.1.2.1 The EUT was set up as shown in Figure 8.1.1 and associated photograph/s, energized and the performance check was conducted.

8.1.2.2 The specified frequency range was investigated with biconilog antenna connected to EMI receiver. To find maximum radiation the turntable was rotated 360°, the measuring antenna height was changed from 1 to 4 m, its polarization was switched from vertical to horizontal and the EUT cables position was varied.

8.1.2.3 The worst test results (the lowest margins) were recorded in Table 8.1.2 and shown in the associated plots.

Figure 8.1.1 Setup for radiated emission measurements in anechoic chamber, table-top equipment

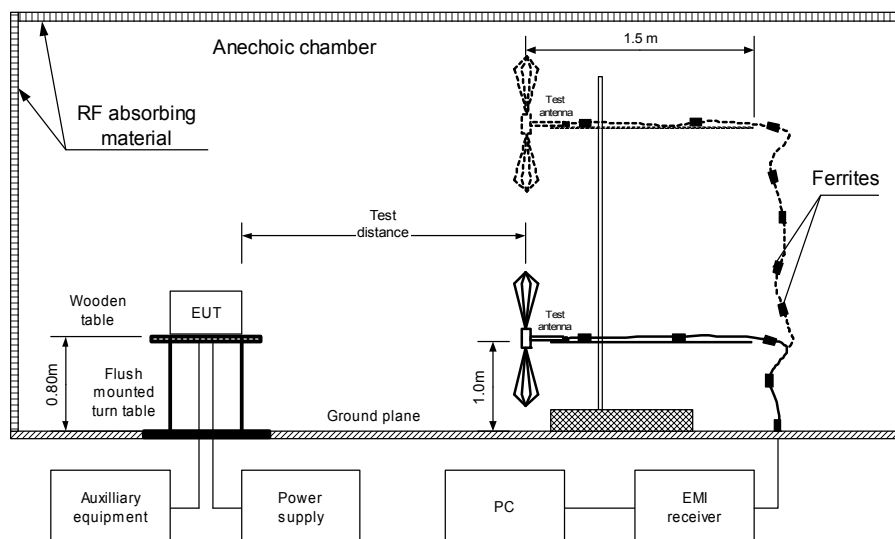



<b>Test specification:</b> Section 15.109/RSS-Gen, section 7.3, ICES-003, Radiated emission			
<b>Test procedure:</b> ANSI C63.4, Sections 11.6 and 12.1.4			
<b>Test mode:</b> Compliance		<b>Verdict:</b> PASS	
<b>Date(s):</b> 28-May-19			
<b>Temperature:</b> 24 °C	<b>Relative Humidity:</b> 48 %	<b>Air Pressure:</b> 1012 hPa	<b>Power:</b> 3.6 VDC
<b>Remarks:</b>			

Table 8.1.2 Radiated emission test results

EUT SET UP: TABLE-TOP  
LIMIT: Class B  
EUT OPERATING MODE: Receive  
TEST SITE: SEMI ANECHOIC CHAMBER  
TEST DISTANCE: 3 m  
DETECTORS USED: PEAK / QUASI-PEAK  
FREQUENCY RANGE: 30 MHz – 1000 MHz  
RESOLUTION BANDWIDTH: 120 kHz

Frequency, MHz	Peak emission, dB(µV/m)	Quasi-peak			Antenna polarization	Antenna height, m	Turn-table position**, degrees	Verdict
		Measured emission, dB(µV/m)	Limit, dB(µV/m)	Margin, dB*				
No emission were found								Pass

TEST SITE: SEMI ANECHOIC CHAMBER  
TEST DISTANCE: 3 m  
DETECTORS USED: PEAK / AVERAGE  
FREQUENCY RANGE: 1000 MHz – 5000 MHz  
RESOLUTION BANDWIDTH: 1000 kHz

Frequency, MHz	Peak			Average			Antenna polarization	Antenna height, m	Turn-table position**, degrees	Verdict
	Measured emission, dB(µV/m)	Limit, dB(µV/m)	Margin, dB*	Measured emission, dB(µV/m)	Limit, dB(µV/m)	Margin, dB*				
No emission were found										Pass

\*- Margin = Measured emission - specification limit.  
\*\*- EUT front panel refer to 0 degrees position of turntable.

Reference numbers of test equipment used

HL 3903	HL 4360	HL 4933	HL 5288	HL 5405			
---------	---------	---------	---------	---------	--	--	--

Full description is given in Appendix A.



HERMON LABORATORIES

<b>Test specification: Section 15.109/RSS-Gen, section 7.3, ICES-003, Radiated emission</b>			
<b>Test procedure:</b> ANSI C63.4, Sections 11.6 and 12.1.4			
<b>Test mode:</b> Compliance		<b>Verdict:</b> PASS	
<b>Date(s):</b> 28-May-19			
<b>Temperature:</b> 24 °C	<b>Relative Humidity:</b> 48 %	<b>Air Pressure:</b> 1012 hPa	<b>Power:</b> 3.6 VDC
<b>Remarks:</b>			

Plot 8.1.1 Radiated emission measurements in 30 - 1000 MHz range, vertical and horizontal antenna polarization

TEST SITE: Semi anechoic chamber  
LIMIT: Class B  
TEST DISTANCE: 3 m  
EUT OPERATING MODE: Receive

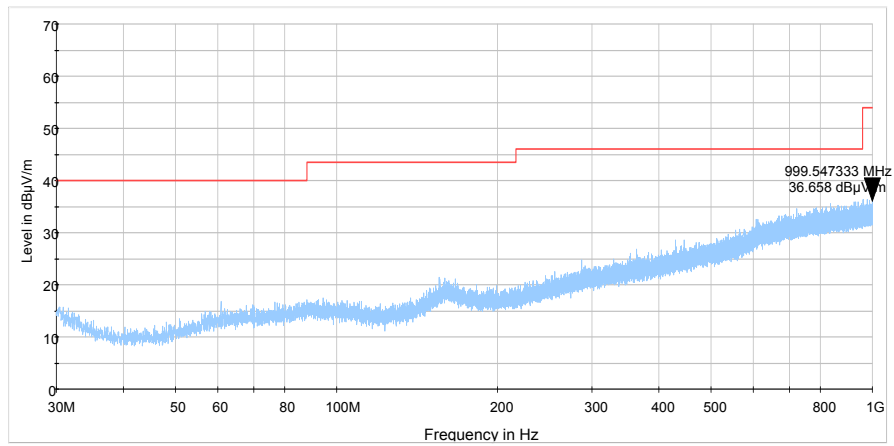

Plot 8.1.2 Radiated emission measurements in 1 - 5 GHz range, vertical and horizontal antenna polarization

TEST SITE: Semi anechoic chamber  
LIMIT: Class B  
TEST DISTANCE: 3 m  
EUT OPERATING MODE: Receive

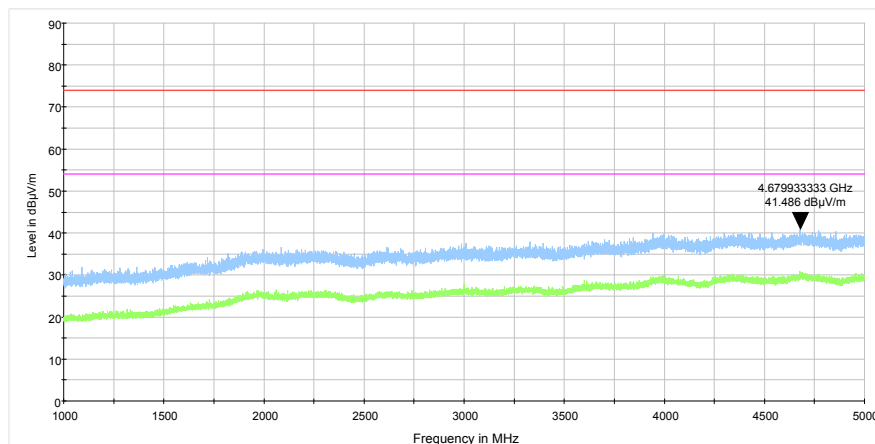



**9 APPENDIX A Test equipment and ancillaries used for tests**

HL No	Description	Manufacturer	Model	Ser. No.	Last Cal./ Check	Due Cal./ Check
0337	Probe Set, Hand held, 5 probes	Electro-Metrics	EHFP-30	238	26-Jun-19	26-Jun-20
0446	Antenna, Loop, Active, 10 (9) kHz - 30 MHz	EMCO	6502	2857	24-Feb-19	24-Feb-20
2909	Spectrum analyzer, ESA-E, 100 Hz to 26.5 GHz	Agilent Technologies	E4407B	MY414447 62	04-Apr-19	04-Apr-20
3903	Microwave Cable Assembly, 40.0 GHz, 1.5 m, SMA/SMA	Huber-Suhner	SUCOFLE X 102A	1226/2A	07-Apr-19	07-Apr-20
4136	Shield Box	TESCOM CO., LTD	TC-5916A	5916A000 137	24-Apr-19	24-Apr-20
4360	EMI Test Receiver, 20 Hz to 40 GHz.	Rohde & Schwarz	ESU40	100322	31-Dec-18	31-Dec-19
4933	Active Horn Antenna, 1 GHz to 18 GHz	COM-POWER CORPORATIO N	AHA-118	701046	06-Jan-19	06-Jan-20
5288	Trilog Antenna, 25 MHz - 8 GHz, 100W	Frankonia	ALX- 8000E	00809	08-Feb-19	08-Feb-22
5405	RF cable, 18 GHz, N-N, 6 m	Huber-Suhner	SF118/11 N(x2)	500023/11 8	11-Aug-19	11-Aug-20



### 10 APPENDIX B Test equipment correction factors

**HL 0446: Active Loop Antenna  
EMCO, model: 6502, s/n 2857**

Frequency,	Measured antenna factor, dBS/m	Measurement uncertainty, dB
10	-33.4	±1.0
20	-37.8	±1.0
50	-40.5	±1.0
75	-41.0	±1.0
100	-41.2	±1.0
150	-41.2	±1.0
250	-41.1	±1.0
500	-41.2	±1.0
750	-41.3	±1.0
1000	-41.3	±1.0

Frequency,	Measured antenna factor, dBS/m	Measurement uncertainty, dB
2000	-41.4	±1.0
3000	-41.4	±1.0
4000	-41.5	±1.0
5000	-41.5	±1.0
10000	-41.7	±1.0
15000	-42.1	±1.0
20000	-42.7	±1.0
25000	-44.2	±1.0
30000	-45.8	±1.0

The antenna factor shall be added to receiver reading in dB $\mu$ V to obtain field strength in dB $\mu$ A/m

**HL 4933: Active Horn Antenna  
COM-POWER CORPORATION, model: AHA-118, s/n 701046**

Frequency, MHz	Measured antenna factor (with preamplifier), dB/m
1000	-16.1
1500	-15.1
2000	-10.9
2500	-11.9
3000	-11.1
3500	-10.6
4000	-8.6
4500	-8.3
5000	-5.9
5500	-5.7
6000	-3.3
6500	-4.0
7000	-2.2
7500	-1.7
8000	1.1
8500	-0.8
9000	-1.5
9500	-0.2

Frequency, MHz	Measured antenna factor (with preamplifier), dB/m
10000	1.8
10500	1.0
11000	0.3
11500	-0.5
12000	3.1
12500	1.4
13000	-0.3
13500	-0.4
14000	2.5
14500	2.2
15000	1.9
15500	0.5
16000	2.1
16500	1.2
17000	0.6
17500	3.1
18000	4.2

The antenna factor shall be added to receiver reading in dB $\mu$ V to obtain field strength in dB $\mu$ V/m



**HL 5288: Trilog Antenna**  
**Frankonia, model: ALX-8000E, s/n: 00809**  
**30-1000 MHz**

Frequency, MHz	Antenna factor, dB/m
30	14.96
35	15.33
40	16.37
45	17.56
50	17.95
60	16.87
70	13.22
80	10.56
90	13.61
100	15.46
120	14.03
140	12.23

Frequency, MHz	Antenna factor, dB/m
160	12.67
180	13.34
200	15.40
250	16.42
300	17.28
400	19.98
500	21.11
600	22.90
700	24.13
800	25.25
900	26.35
1000	27.18

The antenna factor shall be added to receiver reading in dB $\mu$ V to obtain field strength in dB $\mu$ V/m.

**above 1000 MHz**

Frequency, MHz	Antenna factor, dB/m
1000	26.9
1100	28.1
1200	28.4
1300	29.6
1400	29.1
1500	30.4
1600	30.7
1700	31.5
1800	32.3
1900	32.6
2000	32.5
2100	32.9
2200	33.5
2300	33.2
2400	33.7
2500	34.6
2600	34.7
2700	34.6
2800	35.0
2900	35.5
3000	36.2
3100	36.8
3200	36.8
3300	37.0
3400	37.5
3500	38.2

Frequency, MHz	Antenna factor, dB/m
3600	38.9
3700	39.4
3800	39.4
3900	39.6
4000	39.7
4100	39.8
4200	40.5
4300	40.9
4400	41.1
4500	41.4
4600	41.3
4700	41.6
4800	41.9
4900	42.3
5000	42.7
5100	43.0
5200	42.9
5300	43.5
5400	43.6
5500	44.3
5600	44.7
5700	45.0
5800	45.0
5900	45.3
6000	45.9

The antenna factor shall be added to receiver reading in dB $\mu$ V to obtain field strength in dB $\mu$ V/m.



HERMON LABORATORIES

HL 5405: RF Cable  
Huber-Suhner, model: SF118/11N(x2), s/n: 500023/118  
Calibration date: 01-Aug-2018

Set / Applied, MHz	Measured, dB	Uncertainty, dB
0.1	0.01	±0.07
50	0.23	±0.07
100	0.32	±0.07
200	0.45	±0.08
300	0.55	±0.08
400	0.64	±0.08
500	0.71	±0.08
600	0.78	±0.08
700	0.85	±0.08
800	0.91	±0.08
900	0.97	±0.08
1000	1.02	±0.08
1100	1.07	±0.08
1200	1.12	±0.08
1300	1.16	±0.08
1400	1.21	±0.08
1500	1.25	±0.08
1600	1.30	±0.08
1700	1.34	±0.08
1800	1.38	±0.08
1900	1.42	±0.08
2000	1.47	±0.08
2500	1.64	±0.10
3000	1.81	±0.10
3500	1.97	±0.10
4000	2.11	±0.10
4500	2.25	±0.10
5000	2.38	±0.10
5500	2.48	±0.10
6000	2.59	±0.10
6500	2.72	±0.10
7000	2.84	±0.13
7500	2.97	±0.13
8000	3.08	±0.13
8500	3.21	±0.13
9000	3.31	±0.13
9500	3.42	±0.13
10000	3.52	±0.13

**11 APPENDIX C Measurement uncertainties****Expanded uncertainty at 95% confidence in Hermon Labs EMC measurements**

Test description	Expanded uncertainty
Radiated emissions at 10 m measuring distance Horizontal polarization	Biconilog antenna: $\pm 5.0$ dB Biconical antenna: $\pm 5.0$ dB Log periodic antenna: $\pm 5.1$ dB Double ridged horn antenna: $\pm 5.3$ dB
Vertical polarization	Biconilog antenna: $\pm 5.5$ dB Biconical antenna: $\pm 5.5$ dB Log periodic antenna: $\pm 5.6$ dB Double ridged horn antenna: $\pm 5.8$ dB
Radiated emissions at 3 m measuring distance Horizontal polarization	Biconilog antenna: $\pm 5.3$ dB Biconical antenna: $\pm 5.0$ dB Log periodic antenna: $\pm 5.3$ dB Double ridged horn antenna: $\pm 5.3$ dB
Vertical polarization	Biconilog antenna: $\pm 6.0$ dB Biconical antenna: $\pm 5.7$ dB Log periodic antenna: $\pm 6.0$ dB Double ridged horn antenna: $\pm 6.0$ dB
Duty cycle, timing (Tx ON / OFF) and average factor measurements	$\pm 1.0$ %
Occupied bandwidth	$\pm 8.0$ %

Hermon Laboratories is accredited by A2LA for calibration according to present requirements of ISO/IEC 17025 and NCSL Z540-1. The accreditation is granted to perform calibration of parameters that are listed in the Scope of Hermon Laboratories Accreditation.

Hermon Laboratories calibrates its reference and transfer standards by calibration laboratories accredited to ISO/IEC 17025 by a mutually recognized Accreditation Body or by a recognized national metrology institute. All reference and transfer standards used in the calibration system are traceable to national or international standards.

In-house calibration of all test and measurement equipment is performed on a regular basis according to Hermon Laboratories calibration procedures, manufacturer calibration/verification procedures or procedures defined in the relevant standards. The Hermon Laboratories test and measurement equipment is calibrated within the tolerances specified by the manufacturers and/or by the relevant standards.



HERMON LABORATORIES

## 12 APPENDIX D Test laboratory description

Tests were performed at Hermon Laboratories Ltd., which is a fully independent, private, EMC, Radio, Safety, Environmental and Telecommunication testing facility.

Hermon Laboratories is recognized and accredited by the Federal Communications Commission (USA) for 1, 2, 15, 18 parts of Code of Federal Regulations 47 (CFR 47), Test Firm Registration Number is 927748, Designation Number is IL1001; registered by Industry Canada for electromagnetic emissions, file number IC 2186A-1 for OATS, certified by VCCI, Japan (the registration numbers are R-808 for OATS, R-1082 for anechoic chamber, G-869 for RE measurements above 1 GHz, C-845 for conducted emissions site and T-1606 for conducted emissions at telecommunication ports).

The laboratory is accredited by American Association for Laboratory Accreditation (USA) according to ISO/IEC 17025 for electromagnetic compatibility, product safety, telecommunications testing, environmental simulation and calibration (for exact scope please refer to Certificate No. 839.01, 839.03 and 839.04).

Address: P.O. Box 23, Binyamina 3055001, Israel.  
Telephone: +972 4628 8001  
Fax: +972 4628 8277  
e-mail: [mail@hermonlabs.com](mailto:mail@hermonlabs.com)  
website: [www.hermonlabs.com](http://www.hermonlabs.com)

Person for contact: Mr. Michael Nikishin, EMC&Radio group manager



## 13 APPENDIX E

### Specification references

47CFR part 15: 2018

ANSI C63.4:2014

ANSI C63.10:2013

RSS-210 Issue 9: 2016

RSS-Gen:2018, Issue 5

ICES-003:2016, Issue 6

Radio Frequency Devices.

American National Standard for Methods of Measurement of Radio-Noise Emissions from Low-Voltage Electrical and Electronic Equipment in the Range of 9 kHz to 40 GHz.

American National Standard of Procedures for Compliance Testing of Unlicensed Wireless Devices

Licence-Exempt Radio Apparatus: Category I Equipment

General Requirements for Compliance of Radio Apparatus

Information Technology Equipment (Including Digital Apparatus) – Limits and methods of measurement



## 14 APPENDIX F Abbreviations and acronyms

A	ampere
AC	alternating current
A/m	ampere per meter
AM	amplitude modulation
AVRG	average (detector)
cm	centimeter
dB	decibel
dBm	decibel referred to one milliwatt
dB( $\mu$ V)	decibel referred to one microvolt
dB( $\mu$ V/m)	decibel referred to one microvolt per meter
dB( $\mu$ A)	decibel referred to one microampere
DC	direct current
EIRP	equivalent isotropically radiated power
ERP	effective radiated power
EUT	equipment under test
F	frequency
GHz	gigahertz
GND	ground
H	height
HL	Hermon laboratories
Hz	hertz
k	kilo
kHz	kilohertz
LO	local oscillator
m	meter
MHz	megahertz
min	minute
mm	millimeter
ms	millisecond
$\mu$ s	microsecond
NA	not applicable
NB	narrow band
OATS	open area test site
$\Omega$	Ohm
PM	pulse modulation
PS	power supply
ppm	part per million ( $10^{-6}$ )
QP	quasi-peak
RE	radiated emission
RF	radio frequency
rms	root mean square
Rx	receive
s	second
T	temperature
Tx	transmit
V	volt
WB	wideband

END OF DOCUMENT