

FC

Test Report

Product Name	S3 Compact Car SpeakerPhone
Model No.	S3
FCC ID.	VHFBLUEANTS3

Applicant	BlueAnt Wireless
Address	Level 4, Building 1, 658 Church St, Richmond VICTORIA 3121 Australia

Date of Receipt	Oct. 14, 2010
Issued Date	Oct. 21, 2010
Report No.	10A233R-RFUSP29V01
Report Version	V1.0

The Test Results relate only to the samples tested.

The test report shall not be reproduced except in full without the written approval of Quietek Corporation.

This report must not be used to claim product endorsement by NVLAP any agency of the U.S. Government

Test Report Certification

Issued Date: Oct. 21, 2010

Report No.: 10A233R-RFUSP29V01



Product Name	S3 Compact Car SpeakerPhone	
Applicant	BlueAnt Wireless	
Address	Level 4, Building 1, 658 Church St, Richmond VICTORIA 3121 Australia	
Manufacturer	DONG GUAN G-COM COMPUTER CO., LTD.	
Model No.	S3	
FCC ID.	VHFBLUEANTS3	
EUT Rated Voltage	AC Adapter: AC 100-240V, 50 /60Hz; DC Charger: DC 12V/DC 24V	
EUT Test Voltage	AC Adapter: AC 120V/60Hz; DC Charger: DC 12V Transmit mode: DC 5V (Power by USB)	
Trade Name	BlueAnt	
Applicable Standard	FCC CFR Title 47 Part 15 Subpart C: 2009; ANSI C63.4: 2003	 NVLAP Lab Code: 200533-0
Test Result	Complied	

The Test Results relate only to the samples tested.
 The test report shall not be reproduced except in full without the written approval of Quietek Corporation.
 This report must not be used to claim product endorsement by NVLAP any agency of the U.S. Government

Documented By : Leven Huang
 (Senior Adm. Specialist / Leven Huang)



Tested By : Henk Huang
 (Engineer / Henk Huang)



Approved By : Vincent Lin
 (Manager / Vincent Lin)

TABLE OF CONTENTS

Description	Page
1. GENERAL INFORMATION	5
1.1. EUT Description.....	5
1.2. Operational Description.....	7
1.3. Tested System Details.....	8
1.4. Configuration of Tested System	9
1.5. EUT Exercise Software	10
1.6. Test Facility	11
2. CONDUCTED EMISSION	12
2.1. Test Equipment.....	12
2.2. Test Setup	12
2.3. Limits.....	13
2.4. Test Procedure	13
2.5. Uncertainty	13
2.6. Test Result of Conducted Emission.....	14
3. PEAK POWER OUTPUT	20
3.1. Test Equipment.....	20
3.2. Test Setup	20
3.3. Limit	20
3.4. Test Procedure	20
3.5. Uncertainty	20
3.6. Test Result of Peak Power Output.....	21
4. RADIATED EMISSION	23
4.1. Test Equipment.....	23
4.2. Test Setup	23
4.3. Limits.....	24
4.4. Test Procedure	25
4.5. Uncertainty	25
4.6. Test Result of Radiated Emission.....	26
5. RF ANTENNA CONDUCTED TEST	36
5.1. Test Equipment.....	36
5.2. Test Setup	36
5.3. Limits.....	36
5.4. Test Procedure	36
5.5. Uncertainty	36
5.6. Test Result of RF Antenna Conducted Test.....	37
6. BAND EDGE	43
6.1. Test Equipment.....	43
6.2. Test Setup	44
6.3. Limit	45
6.4. Test Procedure	45
6.5. Uncertainty	45
6.6. Test Result of Band Edge	46
7. CHANNEL NUMBER.....	54
7.1. Test Equipment.....	54
7.2. Test Setup	54
7.3. Limit	54
7.4. Test Procedure	54
7.5. Uncertainty	54
7.6. Test Result of Channel Number.....	55
8. CHANNEL SEPARATION.....	57
8.1. Test Equipment.....	57
8.2. Test Setup	57
8.3. Limit	57
8.4. Test Procedure	57
8.5. Uncertainty	57
8.6. Test Result of Channel Separation.....	58
9. DWELL TIME.....	62
9.1. Test Equipment.....	62

9.2.	Test Setup	62
9.3.	Limit	62
9.4.	Test Procedure	62
9.5.	Uncertainty	62
9.6.	Test Result of Dwell Time	63
10.	OCCUPIED BANDWIDTH	67
10.1.	Test Equipment	67
10.2.	Test Setup	67
10.3.	Limits	67
10.4.	Test Procedure	67
10.5.	Uncertainty	67
10.6.	Test Result of Occupied Bandwidth	68
11.	EMI REDUCTION METHOD DURING COMPLIANCE TESTING	74

Attachment 1: EUT Test Photographs

Attachment 2: EUT Detailed Photographs

1. GENERAL INFORMATION

1.1. EUT Description

Product Name	S3 Compact Car SpeakerPhone
Trade Name	BlueAnt
Model No.	S3
FCC ID.	VHFBLUEANTS3
Frequency Range	2402 – 2480MHz
Channel Number	79
Type of Modulation	FHSS: GFSK(1Mbps) / π / 4DQPSK(2Mbps) / 8DPSK(3Mbps)
Antenna Type	Printed on PCB
Channel Control	Auto
Antenna Gain	Refer to the table “Antenna List”
USB Cable	Shielded, 0.5m
USB Cable	Shielded, 0.31m
USB Cable	Shielded, 0.29m
Power Adapter (1)	MFR: BlueAnt, M/N: SSC-5W-05-050050 Input: AC 100-240V,50/60Hz,0.2A Output: DC 5V,500mA
Car Charger (2)	MFR: N/A, M/N: SIL-050050A-CLA Input: DC 12V or DC 24V Output: DC 5V,500mA

Antenna List

No.	Manufacturer	Part No.	Peak Gain
1	WIESON	N/A	0.72dBi for 2.4 GHz

Note: The antenna of EUT is conform to FCC 15.203

Frequency of Each Channel:

Channel	Frequency	Channel	Frequency	Channel	Frequency	Channel	Frequency
Channel 00:	2402 MHz	Channel 20:	2422 MHz	Channel 40:	2442 MHz	Channel 60:	2462 MHz
Channel 01:	2403 MHz	Channel 21:	2423 MHz	Channel 41:	2443 MHz	Channel 61:	2463 MHz
Channel 02:	2404 MHz	Channel 22:	2424 MHz	Channel 42:	2444 MHz	Channel 62:	2464 MHz
Channel 03:	2405 MHz	Channel 23:	2425 MHz	Channel 43:	2445 MHz	Channel 63:	2465 MHz
Channel 04:	2406 MHz	Channel 24:	2426 MHz	Channel 44:	2446 MHz	Channel 64:	2466 MHz
Channel 05:	2407 MHz	Channel 25:	2427 MHz	Channel 45:	2447 MHz	Channel 65:	2467 MHz
Channel 06:	2408 MHz	Channel 26:	2428 MHz	Channel 46:	2448 MHz	Channel 66:	2468 MHz
Channel 07:	2409 MHz	Channel 27:	2429 MHz	Channel 47:	2449 MHz	Channel 67:	2469 MHz
Channel 08:	2410 MHz	Channel 28:	2430 MHz	Channel 48:	2450 MHz	Channel 68:	2470 MHz
Channel 09:	2411 MHz	Channel 29:	2431 MHz	Channel 49:	2451 MHz	Channel 69:	2471 MHz
Channel 10:	2412 MHz	Channel 30:	2432 MHz	Channel 50:	2452 MHz	Channel 70:	2472 MHz
Channel 11:	2413 MHz	Channel 31:	2433 MHz	Channel 51:	2453 MHz	Channel 71:	2473 MHz
Channel 12:	2414 MHz	Channel 32:	2434 MHz	Channel 52:	2454 MHz	Channel 72:	2474 MHz
Channel 13:	2415 MHz	Channel 33:	2435 MHz	Channel 53:	2455 MHz	Channel 73:	2475 MHz
Channel 14:	2416 MHz	Channel 34:	2436 MHz	Channel 54:	2456 MHz	Channel 74:	2476 MHz
Channel 15:	2417 MHz	Channel 35:	2437 MHz	Channel 55:	2457 MHz	Channel 75:	2477 MHz
Channel 16:	2418 MHz	Channel 36:	2438 MHz	Channel 56:	2458 MHz	Channel 76:	2478 MHz
Channel 17:	2419 MHz	Channel 37:	2439 MHz	Channel 57:	2459 MHz	Channel 77:	2479 MHz
Channel 18:	2420 MHz	Channel 38:	2440 MHz	Channel 58:	2460 MHz	Channel 78:	2480 MHz
Channel 19:	2421 MHz	Channel 39:	2441 MHz	Channel 59:	2461 MHz		

Note:

1. This device is a S3 Compact Car SpeakerPhone, with a built-in 2.4GHz Bluetooth V2.1+EDR transceiver
2. These tests were conducted on a sample for the purpose of demonstrating compliance of Bluetooth transmitter with Part 15 Subpart C Paragraph 15.247 for spread spectrum devices.
3. Regarding to the operation frequency, the lowest, middle and highest frequency are selected to perform the test.

Test Mode	Mode 1: AC Charger Mode 2: DC Charger Mode 3: Transmit - 1Mbps (GFSK) Mode 4: Transmit - 3Mbps (8DPSK)
-----------	---

1.3. Tested System Details

The types for all equipment, plus descriptions of all cables used in the tested system (including inserted cards) are:

Mode 1:

Product	Manufacturer	Model No.	Serial No.	FCC ID	Power Cord
N/A					

Mode 2:

Product	Manufacturer	Model No.	Serial No.	FCC ID	Power Cord
1 Battery	YUASA	N/A	N/A	N/A	N/A

Mode 3 & Mode 4:

Product	Manufacturer	Model No.	Serial No.	FCC ID	Power Cord
1 Notebook PC	DELL	PPT	N/A	DoC	Non-Shielded, 0.8m
2 DVD ROM	DELL	PDO1S	03029	N/A	N/A
3 Monitor	LG	W2261VT	907YHZK07303	DoC	Non-Shielded, 1.8m
4 Modem	ACEEX	DM-1414	0102027554	IFAXDM1414	Non-Shielded, 1.8m
5 Microphone & Earphone	PCHOME	N/A	N/A	N/A	N/A

Mode 1:

Signal Cable Type	Signal cable Description
N/A	

Mode 2:

Signal Cable Type	Signal cable Description
A Power Line	Non-Shielded, 1.8m

Mode 3 & Mode 4:

Signal Cable Type	Signal cable Description
A USB Cable	Shielded, 0.5m
B Microphone & Earphone Cable	Non-Shielded, 2m
C D-SUB Cable	Shielded, 1.8m
D RS-232 Cable	Shielded, 1.6m
E USB Cable	Shielded, 0.5m

1.4. Configuration of Tested System

Mode 1:

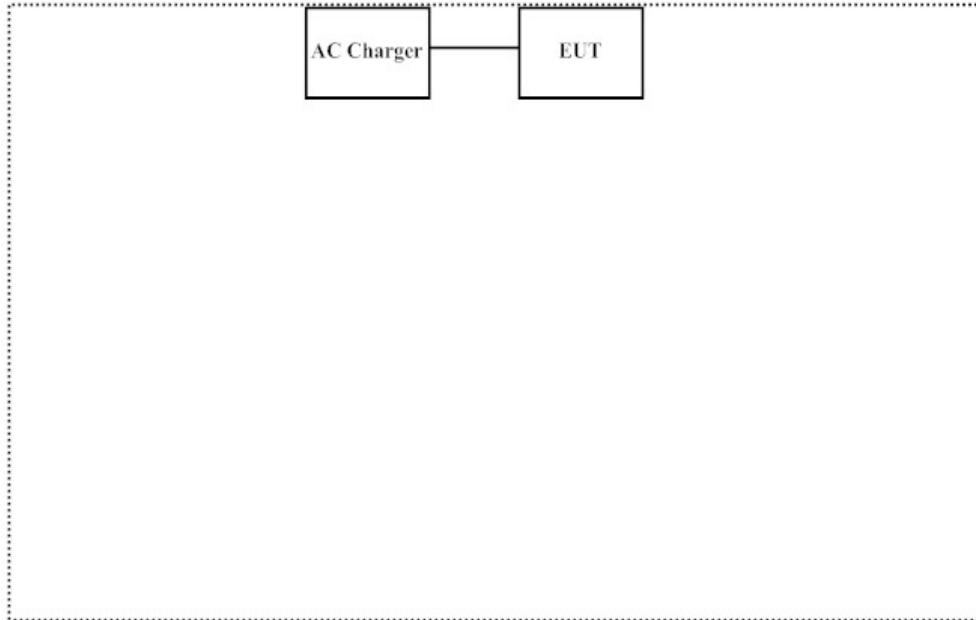

Mode 2:

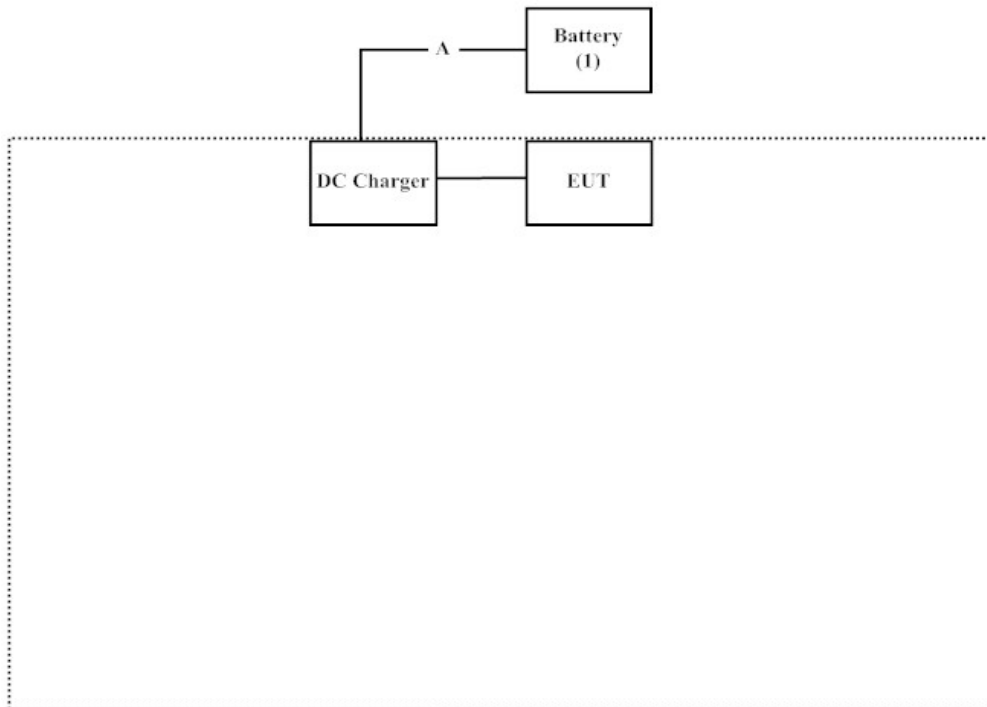

Mode 3 & Mode 4:

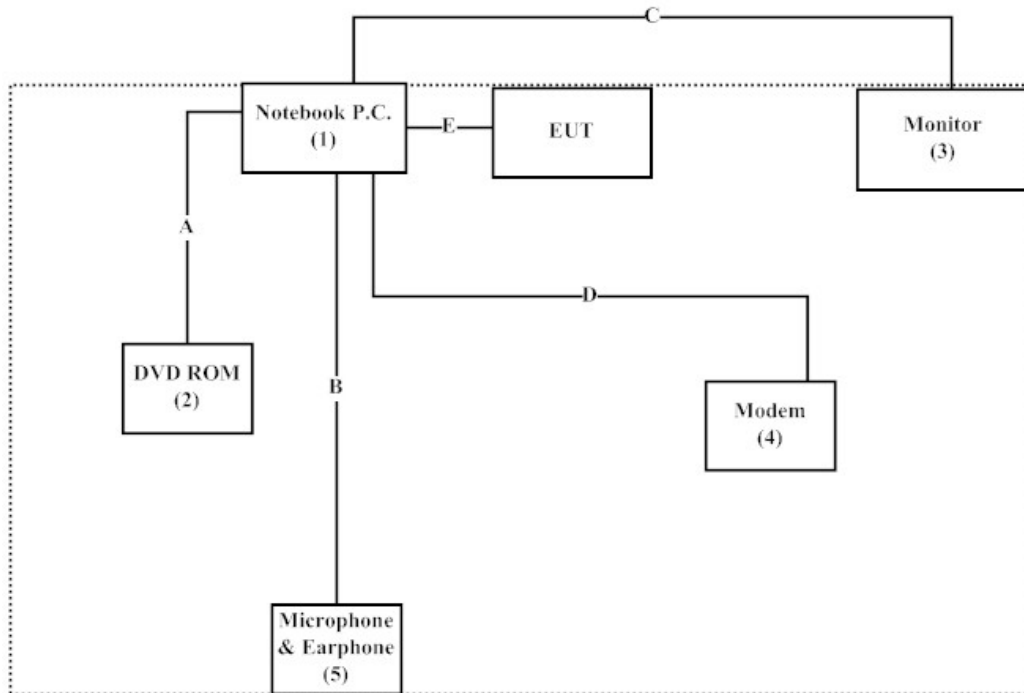

1.5. EUT Exercise Software

- (1) Setup the EUT as shown in Section 1.4.
- (2) Execute Software on the EUT.
- (3) Configure the test mode, the test channel, and the data rate.
- (4) Verify that the EUT works properly.

1.6. Test Facility

Ambient conditions in the laboratory:

Items	Required (IEC 68-1)	Actual
Temperature (°C)	15-35	20-35
Humidity (%RH)	25-75	30-65
Barometric pressure (mbar)	860-1060	950-1000

The related certificate for our laboratories about the test site and management system can be downloaded from Quietek Corporation’s Web Site: <http://www.quietek.com/tw/ctg/cts/accreditations.htm>
 The address and introduction of Quietek Corporation’s laboratories can be founded in our Web site: <http://www.quietek.com/>

Site Description: File on
 Federal Communications Commission
 FCC Engineering Laboratory
 7435 Oakland Mills Road
 Columbia, MD 21046
 Registration Number: 92195



Accreditation on NVLAP
 NVLAP Lab Code: 200533-0



Site Name: Quietek Corporation
 Site Address: No. 5-22, Ruei-Shu Valley, Ruei-Ping Tsuen,
 Lin-Kou Shiang, Taipei,
 Taiwan, R.O.C.
 TEL: 886-2-8601-3788 / FAX : 886-2-8601-3789
 E-Mail : service@quietek.com

FCC Accreditation Number: TW1014



2. Conducted Emission

2.1. Test Equipment

The following test equipment are used during the conducted emission test:

Item	Instrument	Manufacturer	Type No./Serial No	Last Cal.	Remark
1	Test Receiver	R & S	ESCS 30/825442/014	Feb., 2010	
2	L.I.S.N.	R & S	ESH3-Z5/825562/002	Feb., 2010	EUT
3	L.I.S.N.	R & S	ENV4200/848411/010	Feb., 2010	Peripherals
4	Pulse Limiter	R & S	ESH3-Z2/100410	July, 2010	
5	No.1 Shielded Room			N/A	

Note: All instruments are calibrated every one year.

2.2. Test Setup

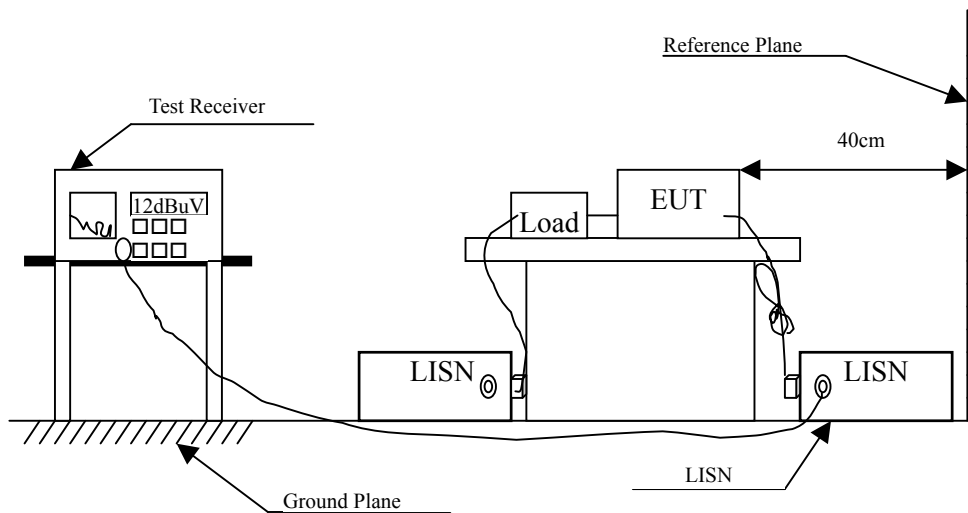

2.3. Limits

FCC Part 15 Subpart C Paragraph 15.207 (dBuV) Limit		
Frequency MHz	Limits	
	QP	AV
0.15 - 0.50	66-56	56-46
0.50-5.0	56	46
5.0 - 30	60	50

Remarks: In the above table, the tighter limit applies at the band edges.

2.4. Test Procedure

The EUT and Peripherals are connected to the main power through a line impedance stabilization network (L.I.S.N.). This provides a 50 ohm /50uH coupling impedance for the measuring equipment. The peripheral devices are also connected to the main power through a LISN that provides a 50ohm /50uH coupling impedance with 50ohm termination. (Please refer to the block diagram of the test setup and photographs.)

Both sides of A.C. line are checked for maximum conducted interference. In order to find the maximum emission, the relative positions of equipment and all the interface cables must be changed according to ANSI C63.4: 2003 on conducted measurement.

Conducted emissions were investigated over the frequency range from 0.15MHz to 30MHz using a receiver bandwidth of 9kHz.

The EUT was setup to ANSI C63.4, 2003; tested to FHSS test procedure of FCC Public Notice DA 00-705 for compliance to FCC 47CFR 15.247 requirements.

2.5. Uncertainty

± 2.26 dB

2.6. Test Result of Conducted Emission

Product : S3 Compact Car SpeakerPhone
 Test Item : Conducted Emission Test
 Power Line : Line 1
 Test Mode : Mode 1: AC Charger

Frequency MHz	Correct Factor dB	Reading Level dBuV	Measurement Level dBuV	Margin dB	Limit dBuV
LINE 1					
Quasi-Peak					
0.162	9.750	39.360	49.110	-16.547	65.657
0.173	9.734	27.180	36.915	-28.428	65.343
0.193	9.711	24.930	34.641	-30.130	64.771
0.298	9.650	29.380	39.030	-22.741	61.771
1.502	9.678	30.280	39.958	-16.042	56.000
2.103	9.680	30.390	40.070	-15.930	56.000
Average					
0.162	9.750	18.670	28.420	-27.237	55.657
0.173	9.734	12.360	22.095	-33.248	55.343
0.193	9.711	10.430	20.141	-34.630	54.771
0.298	9.650	24.750	34.400	-17.371	51.771
1.502	9.678	26.480	36.158	-9.842	46.000
2.103	9.680	26.620	36.300	-9.700	46.000

Note:

1. All Reading Levels are Quasi-Peak and average value.
2. "█" means the worst emission level.
3. Measurement Level = Reading Level + Correct Factor

Product : S3 Compact Car SpeakerPhone
 Test Item : Conducted Emission Test
 Power Line : Line 2
 Test Mode : Mode 1: AC Charger

Frequency MHz	Correct Factor dB	Reading Level dBuV	Measurement Level dBuV	Margin dB	Limit dBuV
LINE 2					
Quasi-Peak					
0.189	9.724	35.080	44.804	-20.082	64.886
0.220	9.703	22.490	32.193	-31.807	64.000
0.295	9.662	21.390	31.052	-30.805	61.857
4.502	9.700	29.030	38.730	-17.270	56.000
5.705	9.720	31.030	40.750	-19.250	60.000
26.439	10.160	3.250	13.410	-46.590	60.000
Average					
0.189	9.724	14.280	24.004	-30.882	54.886
0.220	9.703	7.290	16.993	-37.007	54.000
0.295	9.662	16.230	25.892	-25.965	51.857
4.502	9.700	25.680	35.380	-10.620	46.000
5.705	9.720	27.880	37.600	-12.400	50.000
26.439	10.160	-2.150	8.010	-41.990	50.000

Note:

1. All Reading Levels are Quasi-Peak and average value.
2. "■" means the worst emission level.
3. Measurement Level = Reading Level + Correct Factor

Product : S3 Compact Car SpeakerPhone
 Test Item : Conducted Emission Test
 Power Line : Line (+)
 Test Mode : Mode 2: DC Charger (DC 12V)

Frequency MHz	Correct Factor dB	Reading Level dBuV	Measurement Level dBuV	Margin dB	Limit dBuV
LINE (+)					
Quasi-Peak					
0.713	0.270	14.830	15.100	-40.900	56.000
0.904	0.270	15.070	15.340	-40.660	56.000
2.127	0.271	23.650	23.921	-32.079	56.000
2.306	0.272	22.850	23.122	-32.878	56.000
6.541	0.301	19.070	19.371	-40.629	60.000
17.693	0.653	19.570	20.223	-39.777	60.000
Average					
0.713	0.270	7.120	7.390	-38.610	46.000
0.904	0.270	8.150	8.420	-37.580	46.000
2.127	0.271	1.160	1.431	-44.569	46.000
2.306	0.272	0.660	0.932	-45.068	46.000
6.541	0.301	0.220	0.521	-49.479	50.000
17.693	0.653	14.440	15.093	-34.907	50.000

Note:

1. All Reading Levels are Quasi-Peak and average value.
2. "█" means the worst emission level.
3. Measurement Level = Reading Level + Correct Factor

Product : S3 Compact Car SpeakerPhone
 Test Item : Conducted Emission Test
 Power Line : Line (-)
 Test Mode : Mode 2: DC Charger (DC 12V)

Frequency MHz	Correct Factor dB	Reading Level dBuV	Measurement Level dBuV	Margin dB	Limit dBuV
LINE (-)					
Quasi-Peak					
0.709	0.245	14.010	14.255	-41.745	56.000
0.900	0.242	13.550	13.792	-42.208	56.000
2.142	0.251	2.710	2.961	-53.039	56.000
3.439	0.257	1.850	2.107	-53.893	56.000
6.670	0.278	19.190	19.468	-40.532	60.000
16.232	0.593	19.590	20.183	-39.817	60.000
Average					
0.709	0.245	6.550	6.795	-39.205	46.000
0.900	0.242	5.390	5.632	-40.368	46.000
2.142	0.251	5.260	5.511	-40.489	46.000
3.439	0.257	2.460	2.717	-43.283	46.000
6.670	0.278	3.110	3.388	-46.612	50.000
16.232	0.593	13.440	14.033	-35.967	50.000

Note:

1. All Reading Levels are Quasi-Peak and average value.
2. "■" means the worst emission level.
3. Measurement Level = Reading Level + Correct Factor

Product : S3 Compact Car SpeakerPhone
 Test Item : Conducted Emission Test
 Power Line : Line 1
 Test Mode : Mode 4: Transmit - 3Mbps (8DPSK) (2441MHz)

Frequency MHz	Correct Factor dB	Reading Level dBuV	Measurement Level dBuV	Margin dB	Limit dBuV
LINE 1					
Quasi-Peak					
0.158	9.756	31.120	40.876	-24.895	65.771
0.185	9.719	41.700	51.419	-13.581	65.000
0.240	9.680	36.270	45.950	-17.479	63.429
0.306	9.650	28.830	38.480	-23.063	61.543
0.365	9.650	27.870	37.520	-22.337	59.857
4.060	9.700	33.820	43.520	-12.480	56.000
Average					
0.158	9.756	6.570	16.326	-39.445	55.771
0.185	9.719	34.070	43.789	-11.211	55.000
0.240	9.680	27.470	37.150	-16.279	53.429
0.306	9.650	21.180	30.830	-20.713	51.543
0.365	9.650	19.620	29.270	-20.587	49.857
4.060	9.700	23.980	33.680	-12.320	46.000

Note:

1. All Reading Levels are Quasi-Peak and average value.
2. "■" means the worst emission level.
3. Measurement Level = Reading Level + Correct Factor

Product : S3 Compact Car SpeakerPhone
 Test Item : Conducted Emission Test
 Power Line : Line 2
 Test Mode : Mode 4: Transmit - 3Mbps (8DPSK) (2441MHz)

Frequency MHz	Correct Factor dB	Reading Level dBuV	Measurement Level dBuV	Margin dB	Limit dBuV
LINE 2					
Quasi-Peak					
0.150	9.766	32.120	41.886	-24.114	66.000
0.185	9.727	40.380	50.108	-14.892	65.000
0.248	9.687	28.310	37.997	-25.203	63.200
0.306	9.660	27.810	37.470	-24.073	61.543
0.361	9.653	26.070	35.723	-24.248	59.971
3.939	9.700	31.740	41.440	-14.560	56.000
Average					
0.150	9.766	6.870	16.636	-39.364	56.000
0.185	9.727	33.030	42.758	-12.242	55.000
0.248	9.687	20.190	29.877	-23.323	53.200
0.306	9.660	19.000	28.660	-22.883	51.543
0.361	9.653	19.470	29.123	-20.848	49.971
3.939	9.700	22.840	32.540	-13.460	46.000

Note:

1. All Reading Levels are Quasi-Peak and average value.
2. "■" means the worst emission level.
3. Measurement Level = Reading Level + Correct Factor

3. Peak Power Output

3.1. Test Equipment

	Equipment	Manufacturer	Model No./Serial No.	Last Cal.
X	Power Meter	Anritsu	ML2495A/6K00003357	May, 2010
X	Power Sensor	Anritsu	MA2411B/0738448	Jun, 2010

Note: 1. All equipments are calibrated every one year.
 2. The test instruments marked by “X” are used to measure the final test results.

3.2. Test Setup

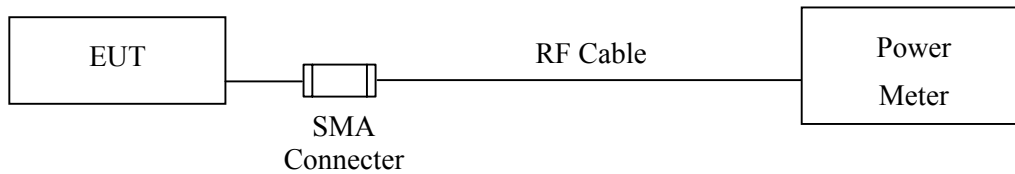

3.3. Limit

The maximum peak power shall be less 1Watt.

3.4. Test Procedure

The EUT was setup to ANSI C63.4, 2003; tested to FHSS test procedure of FCC Public Notice DA 00-705 for compliance to FCC 47CFR 15.247 requirements.

3.5. Uncertainty

± 1.27 dB

3.6. Test Result of Peak Power Output

Product : S3 Compact Car SpeakerPhone
Test Item : Peak Power Output
Test Site : No.3 OATS
Test Mode : Mode 3: Transmit - 1Mbps (GFSK)

Channel No.	Frequency (MHz)	Measurement (dBm)	Required Limit	Result
Channel 00	2402.00	0.67	1 Watt= 30 dBm	Pass
Channel 39	2441.00	0.83	1 Watt= 30 dBm	Pass
Channel 78	2480.00	2.80	1 Watt= 30 dBm	Pass

Product : S3 Compact Car SpeakerPhone
Test Item : Peak Power Output
Test Site : No.3 OATS
Test Mode : Mode 4: Transmit - 3Mbps (8DPSK)

Channel No.	Frequency (MHz)	Measurement (dBm)	Required Limit	Result
Channel 00	2402.00	-0.86	1 Watt= 30 dBm	Pass
Channel 39	2441.00	-0.34	1 Watt= 30 dBm	Pass
Channel 78	2480.00	1.18	1 Watt= 30 dBm	Pass

4. Radiated Emission

4.1. Test Equipment

The following test equipments are used during the radiated emission test:

Test Site		Equipment	Manufacturer	Model No./Serial No.	Last Cal.
☒ Site # 3	X	Bilog Antenna	Schaffner Chase	CBL6112B/2673	Sep., 2010
	X	Horn Antenna	Schwarzbeck	BBHA9120D/D305	Sep., 2010
	X	Horn Antenna	Schwarzbeck	BBHA9170/208	Jul., 2010
	X	Pre-Amplifier	Agilent	8447D/2944A09549	Sep., 2010
	X	Spectrum Analyzer	Agilent	E4407B / US39440758	May, 2010
	X	Test Receiver	R & S	ESCS 30/ 825442/018	Sep., 2010
	X	Coaxial Cable	Quietek	QTK-CABLE/ CAB5	Feb., 2010
	X	Controller	Quietek	QTK-CONTROLLER/ CTRL3	N/A
	X	Coaxial Switch	Anritsu	MP59B/6200265729	N/A

- Note: 1. All equipments are calibrated every one year.
 2. The test instruments marked by "X" are used to measure the final test results.

4.2. Test Setup

Below 1GHz

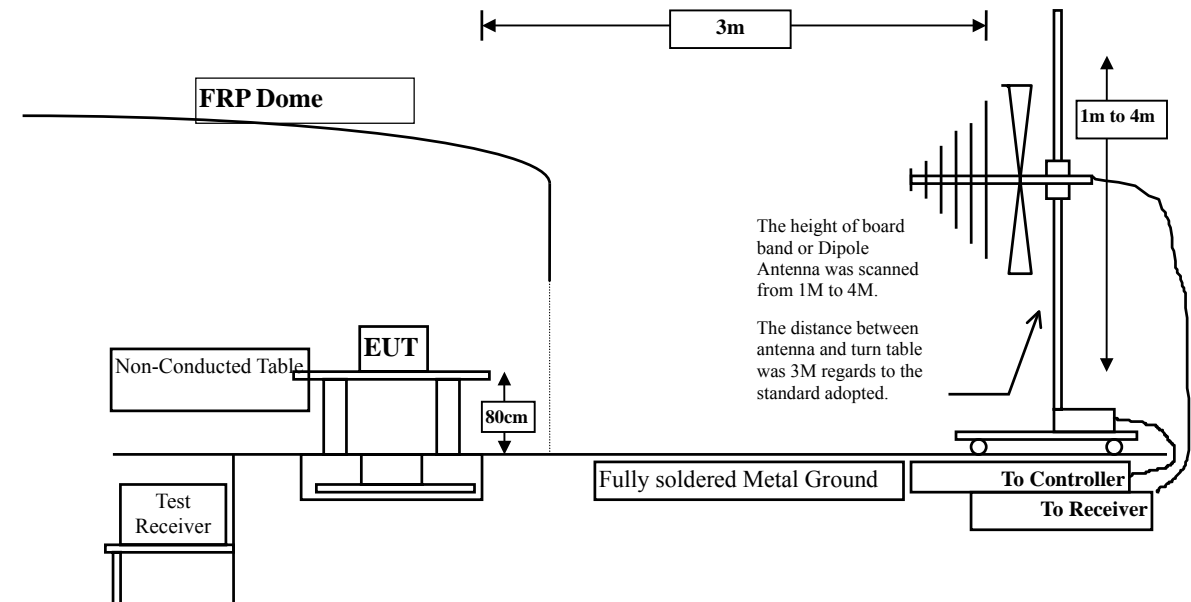

Above 1GHz

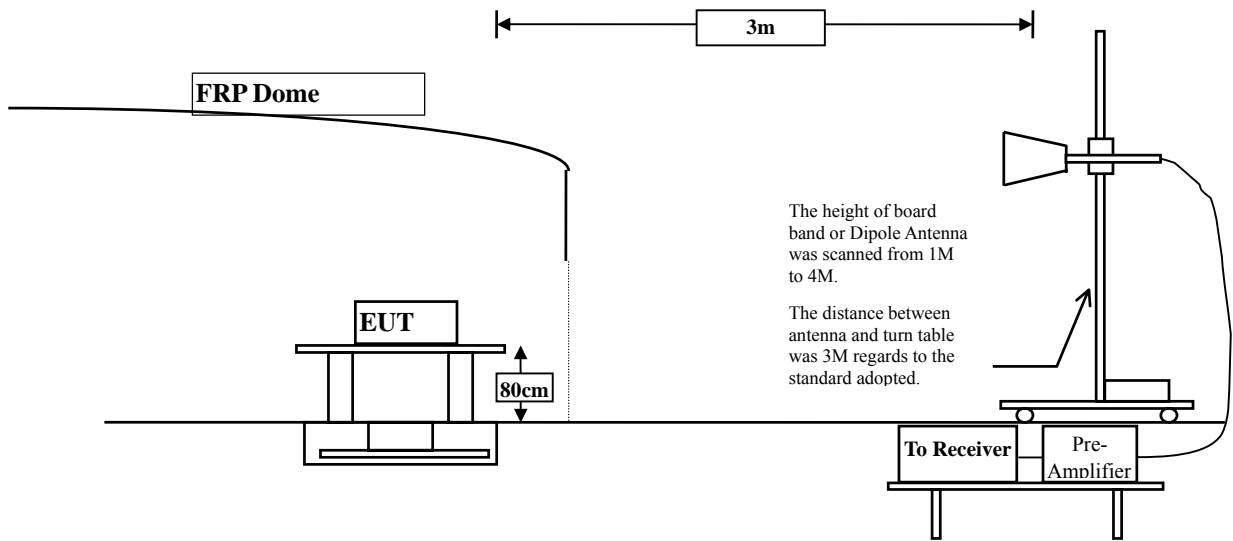

4.3. Limits

➤ General Radiated Emission Limits

Emissions radiated outside of the specified frequency bands, except for harmonics, shall be attenuated by at least 20dB below the level of the fundamental or to the general radiated emission limits in paragraph 15.209, whichever is the lesser attenuation.

FCC Part 15 Subpart C Paragraph 15.209 Limits		
Frequency MHz	uV/m @3m	dBuV/m@3m
30-88	100	40
88-216	150	43.5
216-960	200	46
Above 960	500	54

- Remarks:
1. RF Voltage (dBuV) = 20 log RF Voltage (uV)
 2. In the Above Table, the tighter limit applies at the band edges.
 3. Distance refers to the distance in meters between the measuring instrument antenna and the closed point of any part of the device or system.

4.4. Test Procedure

The EUT was setup according to ANSI C63.4, 2003 and tested according to FHSS test procedure of FCC Public Notice DA 00-705 for compliance to FCC 47CFR 15.247 requirements.

The EUT is placed on a turn table which is 0.8 meter above ground. The turn table is rotated 360 degrees to determine the position of the maximum emission level. The EUT was positioned such that the distance from antenna to the EUT was 3 meters.

The antenna is scanned from 1 meter to 4 meters to find out the maximum emission level. This is repeated for both horizontal and vertical polarization of the antenna. In order to find the maximum emission, all of the interface cables were manipulated according to ANSI C63.4:2003 on radiated measurement.

The resolution bandwidth below 1GHz setting on the field strength meter is 120 kHz and above 1GHz is 1MHz.

Radiated emission measurements below 1GHz are made using broadband Bilog antenna and above 1GHz are made using Horn Antennas.

The measurement is divided into the Preliminary Measurement and the Final Measurement.

The suspected frequencies are searched for in Preliminary Measurement with the measurement antenna kept pointed at the source of the emission both in azimuth and elevation, with the polarization of the antenna oriented for maximum response. The antenna is pointed at an angle towards the source of the emission, and the EUT is rotated in both height and polarization to maximize the measured emission. The emission is kept within the illumination area of the 3 dB bandwidth of the antenna.

The worst radiated emission is measured on the Final Measurement.

The measurement frequency range form 30MHz - 10th Harmonic of fundamental was investigated.

4.5. Uncertainty

± 3.9 dB above 1GHz

± 3.8 dB below 1GHz

4.6. Test Result of Radiated Emission

Product : S3 Compact Car SpeakerPhone
 Test Item : Harmonic Radiated Emission
 Test Site : No.3 OATS
 Test Mode : Mode 3: Transmit - 1Mbps (GFSK)(2402MHz)

Frequency MHz	Correct Factor dB	Reading Level dBuV	Measurement Level dBuV/m	Margin dB	Limit dBuV/m
Horizontal					
Peak Detector:					
4804.000	3.327	49.800	53.127	-20.873	74.000
7206.000	11.005	55.130	66.135	-7.865	74.000
9608.000	13.706	41.460	55.166	-18.834	74.000
Average					
Detector:					
7206.000	11.005	36.720	47.725	-6.275	54.000
9608.000	13.706	27.590	41.296	-12.704	54.000
Vertical					
Peak Detector:					
4804.000	6.638	56.940	63.578	-10.422	74.000
7206.000	11.005	53.390	64.395	-9.605	74.000
9608.000	14.103	37.180	51.283	-22.717	74.000
Average					
Detector:					
4804.000	6.638	38.340	44.977	-9.023	54.000
7206.000	11.005	35.860	46.865	-7.135	54.000

Note:

1. All Readings below 1GHz are Quasi-Peak, above 1GHz are performed with peak and/or average measurements as necessary.
2. Peak measurements: RBW = 1MHz, VBW = 3 MHz, Sweep: Auto.
3. Average measurements: RBW = 1MHz, VBW = 10 Hz, Sweep: Auto.
4. Measurement Level = Reading Level + Correct Factor.
5. Correct Factor = Antenna factor + Cable loss – Amplifier gain.
6. The average measurement was not performed when the peak measured data under the limit of average detection.
7. The emission levels of other frequencies are very lower than the limit and not show in test report.

Product : S3 Compact Car SpeakerPhone
 Test Item : Harmonic Radiated Emission
 Test Site : No.3 OATS
 Test Mode : Mode 3: Transmit - 1Mbps (GFSK)(2441MHz)

Frequency MHz	Correct Factor dB	Reading Level dBuV	Measurement Level dBuV/m	Margin dB	Limit dBuV/m
Horizontal					
Peak Detector:					
4882.000	3.001	48.500	51.501	-22.499	74.000
7323.000	11.846	51.401	63.248	-10.752	74.000
9764.000	12.563	37.580	50.143	-23.857	74.000
Average Detector:					
7323.000	11.846	33.780	45.627	-8.373	54.000
Vertical					
Peak Detector:					
4882.000	5.713	53.060	58.774	-15.226	74.000
7323.000	12.727	49.350	62.078	-11.922	74.000
9764.000	13.028	39.070	52.098	-21.902	74.000
Average Detector:					
4882.000	5.713	36.310	42.024	-11.976	54.000
7323.000	12.727	33.160	45.888	-8.112	54.000

Note:

1. All Readings below 1GHz are Quasi-Peak, above 1GHz are performed with peak and/or average measurements as necessary.
2. Peak measurements: RBW = 1MHz, VBW = 3 MHz, Sweep: Auto.
3. Average measurements: RBW = 1MHz, VBW = 10 Hz, Sweep: Auto.
4. Measurement Level = Reading Level + Correct Factor.
5. Correct Factor = Antenna factor + Cable loss – Amplifier gain.
6. The average measurement was not performed when the peak measured data under the limit of average detection.
7. The emission levels of other frequencies are very lower than the limit and not show in test report.

Product : S3 Compact Car SpeakerPhone
 Test Item : Harmonic Radiated Emission
 Test Site : No.3 OATS
 Test Mode : Mode 3: Transmit - 1Mbps (GFSK)(2480MHz)

Frequency MHz	Correct Factor dB	Reading Level dBuV	Measurement Level dBuV/m	Margin dB	Limit dBuV/m
Horizontal					
Peak Detector:					
4960.000	2.760	43.850	46.610	-27.390	74.000
7440.000	12.567	39.390	51.956	-22.044	74.000
9920.000	13.456	36.140	49.596	-24.404	74.000
Average Detector:					
--					
Vertical					
Peak Detector:					
4960.000	5.557	49.320	54.877	-19.123	74.000
7440.000	13.426	38.940	52.365	-21.635	74.000
9920.000	13.958	35.800	49.758	-24.242	74.000
Average Detector:					
4960.000	5.557	33.810	39.367	-14.633	54.000

Note:

1. All Readings below 1GHz are Quasi-Peak, above 1GHz are performed with peak and/or average measurements as necessary.
2. Peak measurements: RBW = 1MHz, VBW = 3 MHz, Sweep: Auto.
3. Average measurements: RBW = 1MHz, VBW = 10 Hz, Sweep: Auto.
4. Measurement Level = Reading Level + Correct Factor.
5. Correct Factor = Antenna factor + Cable loss – Amplifier gain.
6. The average measurement was not performed when the peak measured data under the limit of average detection.
7. The emission levels of other frequencies are very lower than the limit and not show in test report.

Product : S3 Compact Car SpeakerPhone
 Test Item : Harmonic Radiated Emission
 Test Site : No.3 OATS
 Test Mode : Mode 4: Transmit - 3Mbps (8DPSK)(2402MHz)

Frequency MHz	Correct Factor dB	Reading Level dBuV	Measurement Level dBuV/m	Margin dB	Limit dBuV/m
Horizontal					
Peak Detector:					
4804.000	3.327	48.030	51.357	-22.643	74.000
7206.000	10.136	51.920	62.056	-11.944	74.000
9608.000	13.706	35.690	49.396	-24.604	74.000
Average Detector:					
7206.000	10.136	31.830	41.966	-12.034	54.000
Vertical					
Peak Detector:					
4804.000	6.638	52.870	59.507	-14.493	74.000
7206.000	11.005	49.060	60.065	-13.935	74.000
9608.000	14.103	35.610	49.713	-24.287	74.000
Average Detector:					
4804.000	6.638	33.420	40.057	-13.943	54.000
7206.000	11.005	30.520	41.525	-12.475	54.000

Note:

1. All Readings below 1GHz are Quasi-Peak, above 1GHz are performed with peak and/or average measurements as necessary.
2. Peak measurements: RBW = 1MHz, VBW = 3 MHz, Sweep: Auto.
3. Average measurements: RBW = 1MHz, VBW = 10 Hz, Sweep: Auto.
4. Measurement Level = Reading Level + Correct Factor.
5. Correct Factor = Antenna factor + Cable loss – Amplifier gain.
6. The average measurement was not performed when the peak measured data under the limit of average detection.
7. The emission levels of other frequencies are very lower than the limit and not show in test report.

Product : S3 Compact Car SpeakerPhone
 Test Item : Harmonic Radiated Emission
 Test Site : No.3 OATS
 Test Mode : Mode 4: Transmit - 3Mbps (8DPSK) (2441MHz)

Frequency MHz	Correct Factor dB	Reading Level dBuV	Measurement Level dBuV/m	Margin dB	Limit dBuV/m
Horizontal					
Peak Detector:					
4882.000	3.001	41.500	44.501	-29.499	74.000
7323.000	11.846	45.470	57.317	-16.683	74.000
9764.000	12.563	36.420	48.983	-25.017	74.000
Average Detector:					
7323.000	11.846	27.770	39.617	-14.383	54.000
Vertical					
Peak Detector:					
4882.000	5.713	47.960	53.674	-20.326	74.000
7323.000	11.846	43.300	55.147	-18.853	74.000
9764.000	13.028	36.240	49.268	-24.732	74.000
Average Detector:					
7323.000	11.846	26.490	38.336	-15.664	54.000

Note:

1. All Readings below 1GHz are Quasi-Peak, above 1GHz are performed with peak and/or average measurements as necessary.
2. Peak measurements: RBW = 1MHz, VBW = 3 MHz, Sweep: Auto.
3. Average measurements: RBW = 1MHz, VBW = 10 Hz, Sweep: Auto.
4. Measurement Level = Reading Level + Correct Factor.
5. Correct Factor = Antenna factor + Cable loss – Amplifier gain.
6. The average measurement was not performed when the peak measured data under the limit of average detection.
7. The emission levels of other frequencies are very lower than the limit and not show in test report.

Product : S3 Compact Car SpeakerPhone
 Test Item : Harmonic Radiated Emission
 Test Site : No.3 OATS
 Test Mode : Mode 4: Transmit - 3Mbps (8DPSK) (2480MHz)

Frequency MHz	Correct Factor dB	Reading Level dBuV	Measurement Level dBuV/m	Margin dB	Limit dBuV/m
Horizontal					
Peak Detector:					
4960.000	2.760	42.850	45.610	-28.390	74.000
7440.000	12.567	36.260	48.826	-25.174	74.000
9920.000	13.456	36.080	49.536	-24.464	74.000
Average Detector:					
--					
Vertical					
Peak Detector:					
4960.000	5.557	45.270	50.827	-23.173	74.000
7440.000	13.426	35.320	48.745	-25.255	74.000
9920.000	13.958	36.070	50.028	-23.972	74.000
Average Detector:					
--					

Note:

1. All Readings below 1GHz are Quasi-Peak, above 1GHz are performed with peak and/or average measurements as necessary.
2. Peak measurements: RBW = 1MHz, VBW = 3 MHz, Sweep: Auto.
3. Average measurements: RBW = 1MHz, VBW = 10 Hz, Sweep: Auto.
4. Measurement Level = Reading Level + Correct Factor.
5. Correct Factor = Antenna factor + Cable loss – Amplifier gain.
6. The average measurement was not performed when the peak measured data under the limit of average detection.
7. The emission levels of other frequencies are very lower than the limit and not show in test report.

Product : S3 Compact Car SpeakerPhone
 Test Item : General Radiated Emission
 Test Site : No.3 OATS
 Test Mode : Mode 1: AC Charger

Frequency MHz	Correct Factor dB	Reading Level dBuV	Measurement Level dBuV/m	Margin dB	Limit dBuV/m
Horizontal					
37.760	-3.889	26.809	22.920	-17.080	40.000
119.240	-9.621	28.991	19.370	-24.130	43.500
243.400	-6.441	30.203	23.762	-22.238	46.000
375.320	-1.209	26.638	25.429	-20.571	46.000
544.100	3.512	25.069	28.581	-17.419	46.000
881.660	6.307	23.827	30.134	-15.866	46.000
Vertical					
31.940	-0.487	26.816	26.330	-13.670	40.000
99.840	-0.021	25.670	25.649	-17.851	43.500
344.280	-3.171	26.339	23.169	-22.831	46.000
544.100	-0.688	23.593	22.905	-23.095	46.000
693.480	2.168	23.717	25.885	-20.115	46.000
941.800	6.585	22.934	29.519	-16.481	46.000

Note:

1. All Readings below 1GHz are Quasi-Peak, above 1GHz are performed with peak and/or average measurements as necessary.
2. Peak measurements: RBW = 1MHz, VBW = 3 MHz, Sweep: Auto.
3. Average measurements: RBW = 1MHz, VBW = 10 Hz, Sweep: Auto.
4. Measurement Level = Reading Level + Correct Factor.
5. Correct Factor = Antenna factor + Cable loss – Amplifier gain.
6. The average measurement was not performed when the peak measured data under the limit of average detection.
7. The emission levels of other frequencies are very lower than the limit and not show in test report.

Product : S3 Compact Car SpeakerPhone
 Test Item : General Radiated Emission
 Test Site : No.3 OATS
 Test Mode : Mode 2: DC Charger

Frequency MHz	Correct Factor dB	Reading Level dBuV	Measurement Level dBuV/m	Margin dB	Limit dBuV/m
Horizontal					
30.000	2.120	22.937	25.057	-14.943	40.000
101.780	-7.141	28.304	21.163	-22.337	43.500
284.140	-4.894	32.949	28.055	-17.945	46.000
544.100	3.512	25.136	28.648	-17.352	46.000
745.860	3.308	25.242	28.550	-17.450	46.000
860.320	5.656	29.683	35.339	-10.661	46.000
Vertical					
55.220	-4.699	30.113	25.414	-14.586	40.000
99.840	-0.021	26.158	26.137	-17.363	43.500
377.260	-1.765	24.433	22.668	-23.332	46.000
544.100	-0.688	23.575	22.887	-23.113	46.000
683.780	1.968	24.049	26.017	-19.983	46.000
934.040	5.792	23.168	28.960	-17.040	46.000

Note:

1. All Readings below 1GHz are Quasi-Peak, above 1GHz are performed with peak and/or average measurements as necessary.
2. Peak measurements: RBW = 1MHz, VBW = 3 MHz, Sweep: Auto.
3. Average measurements: RBW = 1MHz, VBW = 10 Hz, Sweep: Auto.
4. Measurement Level = Reading Level + Correct Factor.
5. Correct Factor = Antenna factor + Cable loss – Amplifier gain.
6. The average measurement was not performed when the peak measured data under the limit of average detection.
7. The emission levels of other frequencies are very lower than the limit and not show in test report.

Product : S3 Compact Car SpeakerPhone
 Test Item : General Radiated Emission
 Test Site : No.3 OATS
 Test Mode : Mode 3: Transmit - 1Mbps (GFSK) (2441MHz)

Frequency MHz	Correct Factor dB	Reading Level dBuV	Measurement Level dBuV/m	Margin dB	Limit dBuV/m
Horizontal					
41.640	-3.949	31.170	27.221	-12.779	40.000
119.240	-9.621	41.020	31.399	-12.101	43.500
218.180	-10.619	45.318	34.698	-11.302	46.000
468.440	1.195	31.993	33.188	-12.812	46.000
664.380	2.062	31.154	33.216	-12.784	46.000
914.640	6.083	25.892	31.975	-14.025	46.000
Vertical					
35.820	-2.159	36.665	34.506	-5.494	40.000
111.480	-0.954	32.087	31.133	-12.367	43.500
229.820	-8.512	51.355	42.843	-3.157	46.000
507.240	-0.471	37.270	36.799	-9.201	46.000
687.660	2.444	27.190	29.634	-16.366	46.000
949.560	6.615	25.205	31.820	-14.180	46.000

Note:

1. All Readings below 1GHz are Quasi-Peak, above 1GHz are performed with peak and/or average measurements as necessary.
2. Peak measurements: RBW = 1MHz, VBW = 3 MHz, Sweep: Auto.
3. Average measurements: RBW = 1MHz, VBW = 10 Hz, Sweep: Auto.
4. Measurement Level = Reading Level + Correct Factor.
5. Correct Factor = Antenna factor + Cable loss – Amplifier gain.
6. The average measurement was not performed when the peak measured data under the limit of average detection.
7. The emission levels of other frequencies are very lower than the limit and not show in test report.

Product : S3 Compact Car SpeakerPhone
 Test Item : General Radiated Emission
 Test Site : No.3 OATS
 Test Mode : Mode 4: Transmit - 3Mbps (8DPSK) (2441MHz)

Frequency MHz	Correct Factor dB	Reading Level dBuV	Measurement Level dBuV/m	Margin dB	Limit dBuV/m
Horizontal					
41.640	-3.949	31.011	27.062	-12.938	40.000
119.240	-9.621	41.548	31.927	-11.573	43.500
216.240	-10.707	46.847	36.140	-9.860	46.000
507.240	0.759	35.723	36.482	-9.518	46.000
749.740	3.320	29.937	33.257	-12.743	46.000
996.120	7.669	40.594	48.263	-5.737	54.000
Vertical					
35.820	-2.159	35.462	33.303	-6.697	40.000
249.220	-7.634	48.149	40.515	-5.485	46.000
507.240	-0.471	37.062	36.591	-9.409	46.000
749.740	2.510	34.128	36.638	-9.362	46.000
941.800	6.585	25.474	32.059	-13.941	46.000
1000.000	4.329	39.127	43.456	-10.544	54.000

Note:

1. All Readings below 1GHz are Quasi-Peak, above 1GHz are performed with peak and/or average measurements as necessary.
2. Peak measurements: RBW = 1MHz, VBW = 3 MHz, Sweep: Auto.
3. Average measurements: RBW = 1MHz, VBW = 10 Hz, Sweep: Auto.
4. Measurement Level = Reading Level + Correct Factor.
5. Correct Factor = Antenna factor + Cable loss – Amplifier gain.
6. The average measurement was not performed when the peak measured data under the limit of average detection.
7. The emission levels of other frequencies are very lower than the limit and not show in test report.

5. RF Antenna Conducted Test

5.1. Test Equipment

	Equipment	Manufacturer	Model No./Serial No.	Last Cal.
	Spectrum Analyzer	R&S	FSP40 / 100170	Jun, 2010
	Spectrum Analyzer	Agilent	E4407B / US39440758	Jun, 2010
X	Spectrum Analyzer	Agilent	N9010A / MY48030495	Apr., 2010

Note: 1. All equipments are calibrated every one year.
 2. The test instruments Marked “X” are used to measure the final test results.

5.2. Test Setup

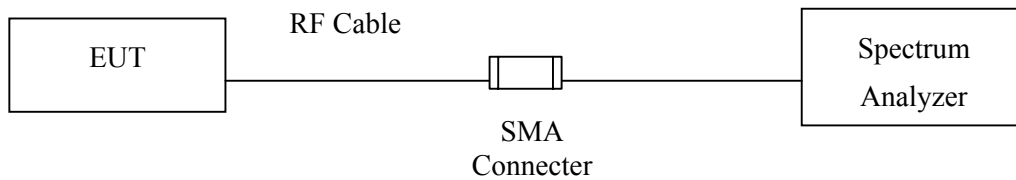

5.3. Limits

According to FCC Section 15.247(d). In any 100 kHz bandwidth outside the frequency band in which the spread spectrum or digitally modulated intentional radiator is operating, the radio frequency power that is produced by the intentional radiator shall be at least 20 dB below that in the 100 kHz bandwidth within the band that contains the highest level of the desired power, based on either an RF conducted or measurement, provided the transmitter demonstrates compliance with the peak conducted power limits. If the transmitter complies with the conducted power limits based on the use of RMS averaging over a time interval, the attenuation required under this paragraph shall be 30 dB instead of 20 dB.

5.4. Test Procedure

The EUT was setup to ANSI C63.4, 2003; tested to FHSS test procedure of FCC Public Notice DA 00-705 for compliance to FCC 47CFR 15.247 requirements.

5.5. Uncertainty

± 150Hz

5.6. Test Result of RF Antenna Conducted Test

Product : S3 Compact Car SpeakerPhone
 Test Item : RF Antenna Conducted Test
 Test Site : No.3 OATS
 Test Mode : Mode 3: Transmit - 1Mbps (GFSK)

Figure Channel 00: 30MHz-25GHz

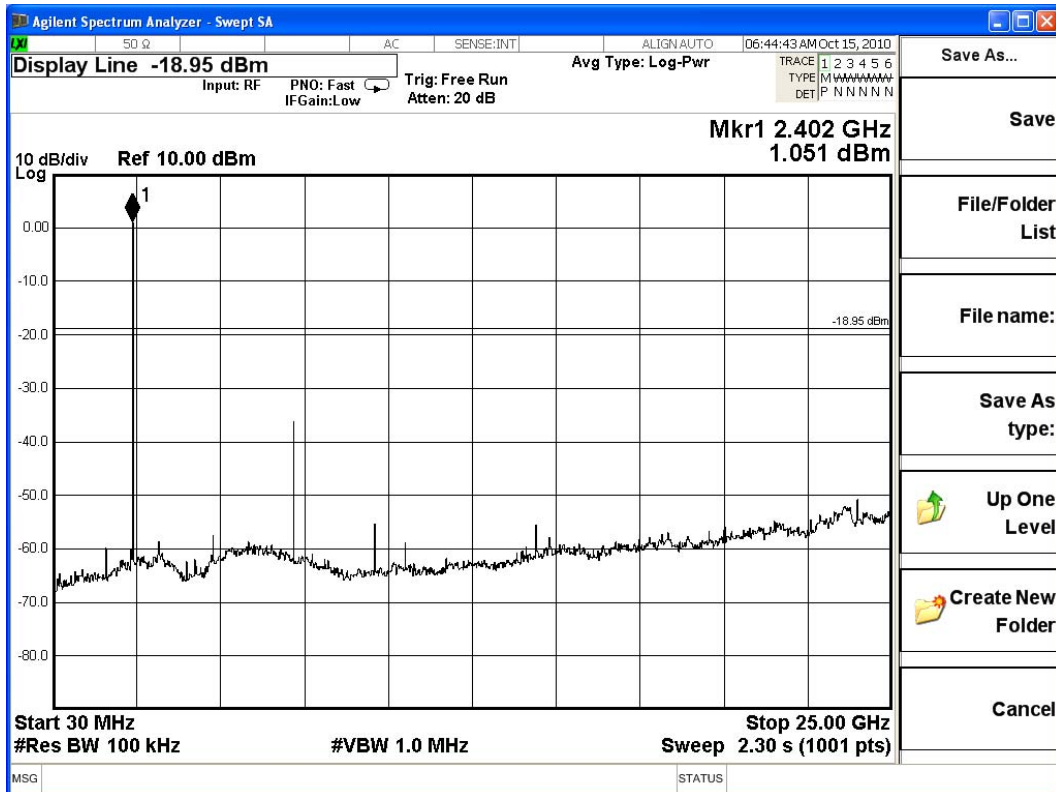

Product : S3 Compact Car SpeakerPhone
 Test Item : RF Antenna Conducted Test
 Test Site : No.3 OATS
 Test Mode : Mode 3: Transmit - 1Mbps (GFSK)

Figure Channel 39: 30MHz-25GHz

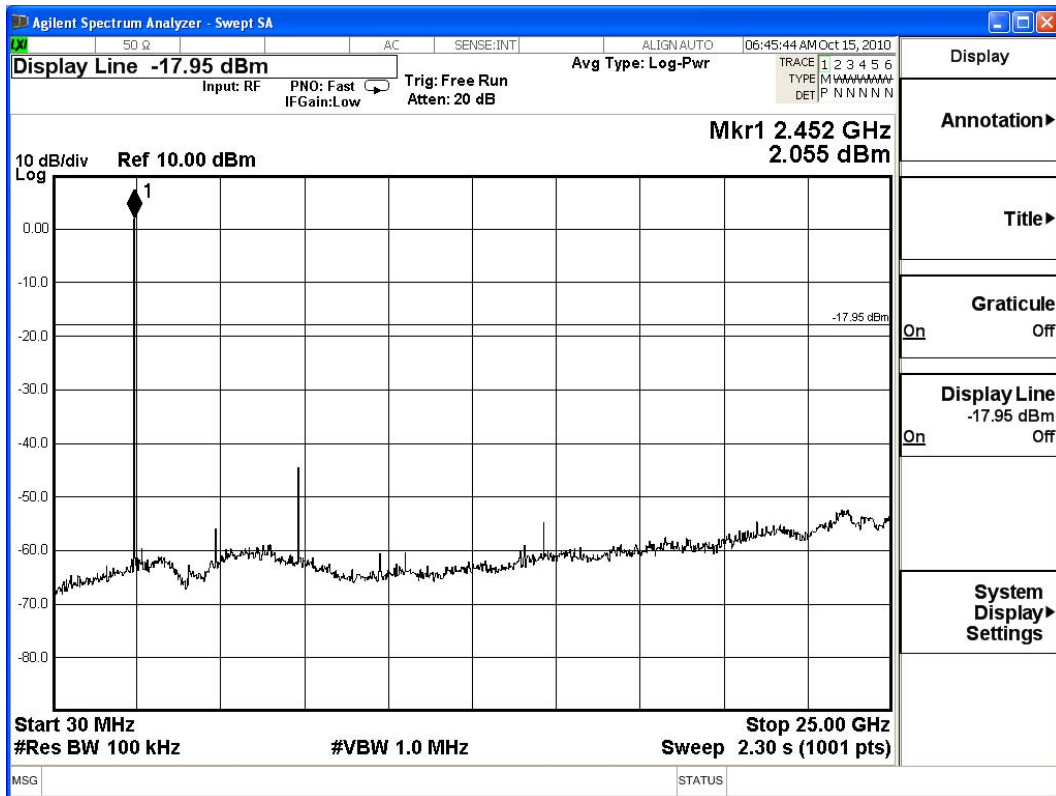

Product : S3 Compact Car SpeakerPhone
 Test Item : RF Antenna Conducted Test
 Test Site : No.3 OATS
 Test Mode : Mode 3: Transmit - 1Mbps (GFSK)

Figure Channel 78: 30MHz-25GHz

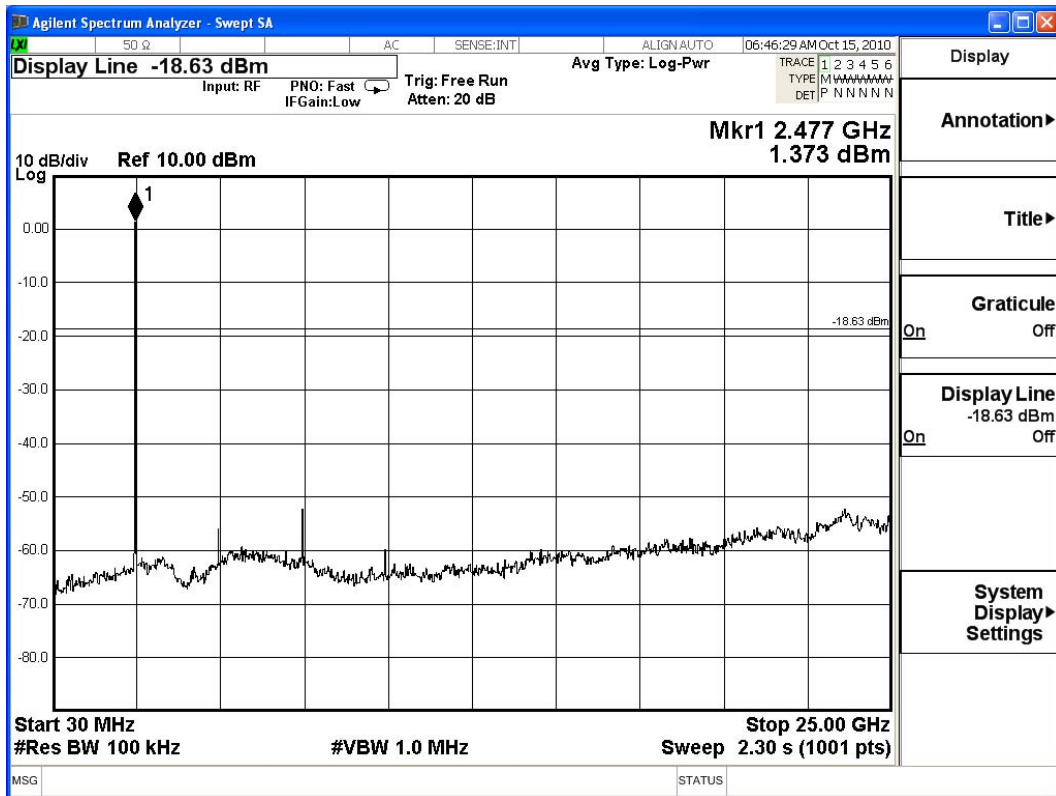

Product : S3 Compact Car SpeakerPhone
 Test Item : RF Antenna Conducted Test
 Test Site : No.3 OATS
 Test Mode : Mode 4: Transmit - 3Mbps (8DPSK)

Figure Channel 00: 30MHz-25GHz



Product : S3 Compact Car SpeakerPhone
 Test Item : RF Antenna Conducted Test
 Test Site : No.3 OATS
 Test Mode : Mode 4: Transmit - 3Mbps (8DPSK)

Figure Channel 39: 30MHz-25GHz

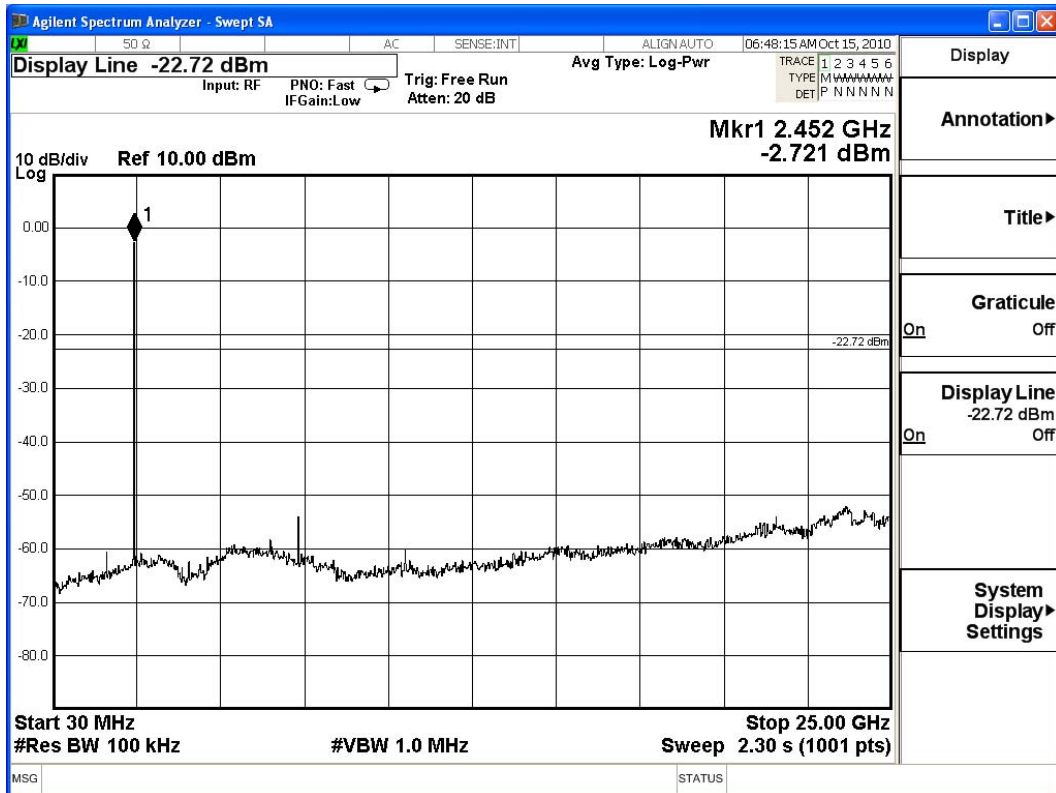

Product : S3 Compact Car SpeakerPhone
 Test Item : RF Antenna Conducted Test
 Test Site : No.3 OATS
 Test Mode : Mode 4: Transmit - 3Mbps (8DPSK)

Figure Channel 78: 30MHz-25GHz



6. Band Edge

6.1. Test Equipment

RF Conducted Measurement

The following test equipments are used during the band edge tests:

	Equipment	Manufacturer	Model No./Serial No.	Last Cal.
	Spectrum Analyzer	R&S	FSP40 / 100170	Jun, 2010
	Spectrum Analyzer	Agilent	E4407B / US39440758	Jun, 2010
X	Spectrum Analyzer	Agilent	N9010A / MY48030495	Apr., 2010

RF Radiated Measurement:

The following test equipments are used during the band edge tests:

Test Site		Equipment	Manufacturer	Model No./Serial No.	Last Cal.
☒ Site # 3		Bilog Antenna	Schaffner Chase	CBL6112B/2673	Sep., 2010
	X	Horn Antenna	Schwarzbeck	BBHA9120D/D305	Sep., 2010
		Horn Antenna	Schwarzbeck	BBHA9170/208	Jul., 2010
	X	Pre-Amplifier	Agilent	8447D/2944A09549	Sep., 2010
	X	Spectrum Analyzer	Agilent	E4407B / US39440758	May, 2010
		Test Receiver	R & S	ESCS 30/ 825442/018	Sep., 2010
	X	Coaxial Cable	Quietek	QTK-CABLE/ CAB5	Feb., 2010
	X	Controller	Quietek	QTK-CONTROLLER/ CTRL3	N/A
	X	Coaxial Switch	Anritsu	MP59B/6200265729	N/A

- Note:
1. All equipments are calibrated every one year.
 2. The test instruments marked by "X" are used to measure the final test results.

6.2. Test Setup

RF Conducted Measurement

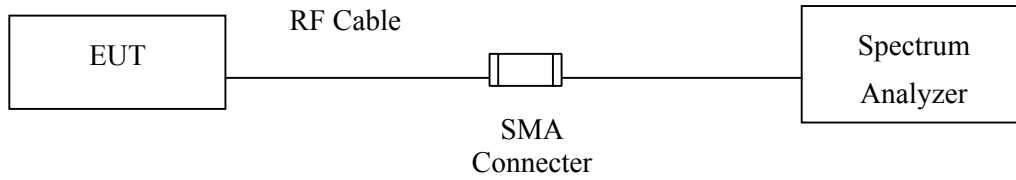

RF Radiated Measurement:

Above 1GHz

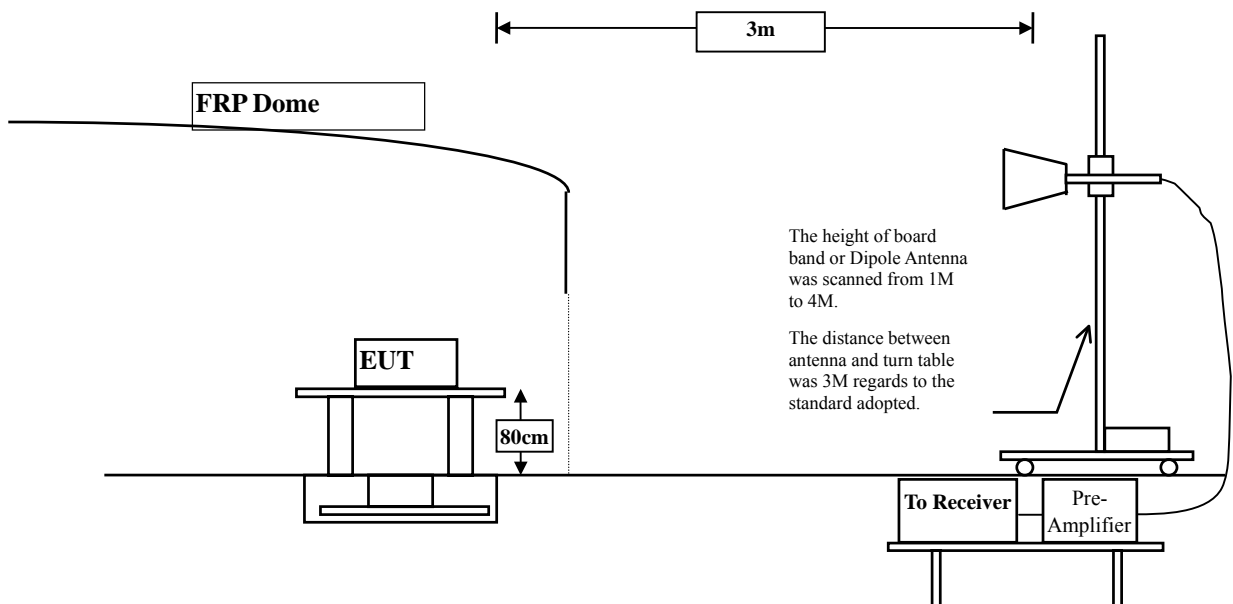

6.3. Limit

In any 100 kHz bandwidth outside the frequency band in which the spread spectrum intentional radiator is operating, the radio frequency power that is produced by the intentional radiator shall be at least 20 dB below that in the 100 kHz bandwidth within the band that contains the highest level of the desired power, based on either an RF conducted or a radiated measurement. Attenuation below the general limits specified in Section 15.209(a) is not required. In addition, radiated emissions which fall in the restricted bands, as defined in Section 15.205(a), must also comply with the radiated emission limits specified in Section 15.209(a) (see Section 15.205(c)).

6.4. Test Procedure

The EUT and its simulators are placed on a turn table which is 0.8 meter above ground. The turn table can rotate 360 degrees to determine the position of the maximum emission level. The EUT was positioned such that the distance from antenna to the EUT was 3 meters.

The antenna can move up and down between 1 meter and 4 meters to find out the maximum emission level.

Both horizontal and vertical polarization of the antenna are set on measurement. In order to find the maximum emission, all of the interface cables must be manipulated according to ANSI C63.4:2003 on radiated measurement.

The bandwidth below 1GHz setting on the field strength meter is 120 kHz, above 1GHz are 1 MHz. The EUT was setup to ANSI C63.4, 2003; tested to FHSS test procedure of FCC Public Notice DA 00-705 for compliance to FCC 47CFR 15.247 requirements.

6.5. Uncertainty

± 3.9 dB above 1GHz

± 3.8 dB below 1GHz

6.6. Test Result of Band Edge

Product : S3 Compact Car SpeakerPhone
 Test Item : Band Edge
 Test Site : No.3 OATS
 Test Mode : Mode 3: Transmit - 1Mbps (GFSK)

Fundamental Filed Strength

Antenna Pole	Frequency [MHz]	Correction Factor [dB/m]	Reading Level [dBuV]	Emission Level [dBuV/m]	Detector
Horizontal	2402	31.573	63.383	94.957	Peak
Vertical	2402	30.917	71.138	102.055	Peak

Note: 1:Spectrum Analyzer setting:

Peak detector: RBW=1MHz, VBW=1MHz

Average detector: RBW=1MHz, VBW=10Hz

Band Edge Test Data

Antenna Pole	Test Frequency (MHz)	Fundamental (dBuV/m)	Δ (dB)	Band Edge Field Strength (dBuV/m)	Detector
Horizontal	2375.9	94.957	58.401	36.556	Peak
Vertical	2375.9	102.055	58.401	43.654	Peak

Note:

The Band Edge Field Strength was calculated using the Fundamental and Conducted Band Edge measurements per the Marker-Delta Method with the following formula:

Band Edge field Strength = F - Δ

F = Fundamental field Strength (Peak or Average)

Δ = Conducted Band Edge Delta (Peak or Average)

Peak limit = 74dBuV/m, Average limit = 54dBuV/m

Peak Detector of conducted Band Edge Delta

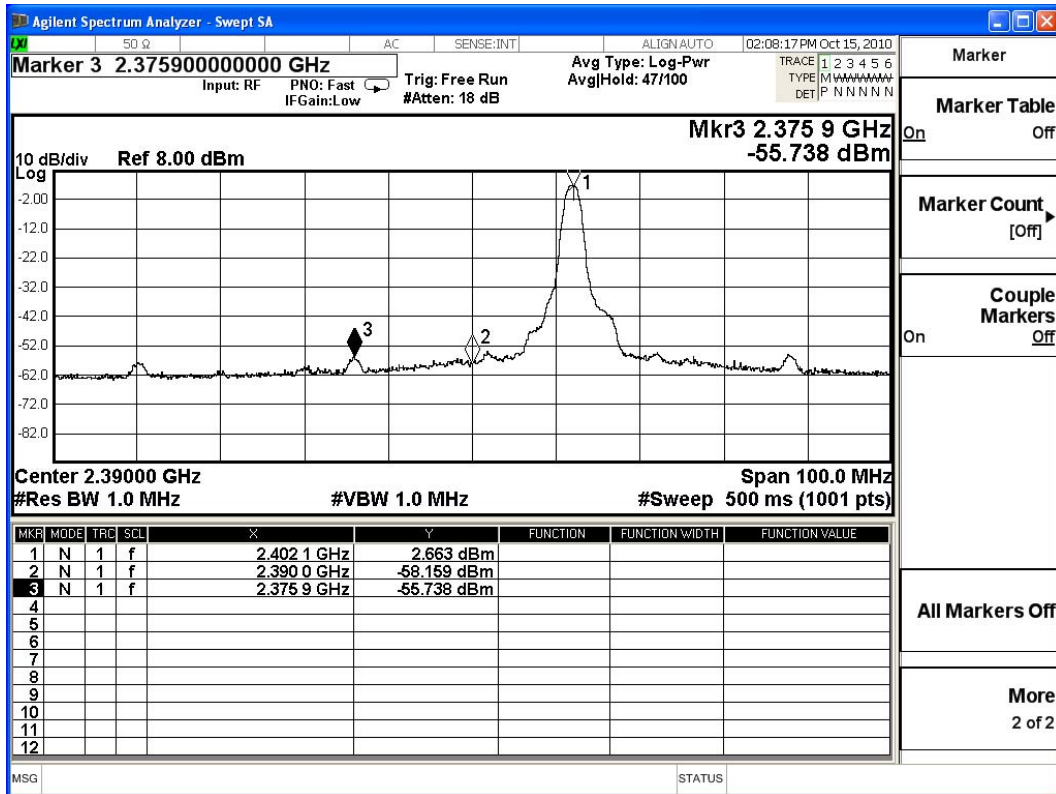

50 Ω AC SENSE:INT ALIGN AUTO 02:08:17 PM Oct 15, 2010
Marker 3 2.375900000000 GHz Input: RF PNO: Fast IFGain:Low Trig: Free Run #Atten: 18 dB Avg Type: Log-Pwr AvgHold: 47/100
 TRACE 1 2 3 4 5 6
 TYPE M M M M M M M M
 DET P N N N N N N

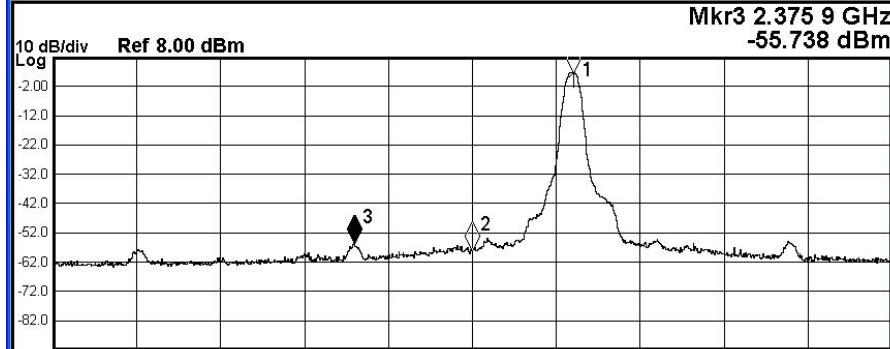

MKR	MODE	TRC	SCL	X	Y	FUNCTION	FUNCTION WIDTH	FUNCTION VALUE
1	N	1	f	2.402 1 GHz	2.663 dBm			
2	N	1	f	2.390 0 GHz	-58.159 dBm			
3	N	1	f	2.375 9 GHz	-55.738 dBm			
4								
5								
6								
7								
8								
9								
10								
11								
12								

Product : S3 Compact Car SpeakerPhone
 Test Item : Band Edge
 Test Site : No.3 OATS
 Test Mode : Mode 3: Transmit - 1Mbps (GFSK)

Fundamental Filed Strength

Antenna Pole	Frequency [MHz]	Correction Factor [dB/m]	Reading Level [dBuV]	Emission Level [dB(uV/m)]	Detector
Horizontal	2480	32.155	67.98	100.136	Peak
Vertical	2480	31.412	73.22	104.632	Peak
Vertical	2480	31.412	42.01	73.422	Average

Note: 1:Spectrum Analyzer setting:

Peak detector: RBW=1MHz, VBW=1MHz

Average detector: RBW=1MHz, VBW=10Hz

Band Edge Test Data

Antenna Pole	Test Frequency (MHz)	Fundamental (dBuV/m)	Δ (dB)	Band Edge Field Strength (dBuV/m)	Detector
Horizontal	2483.5	100.136	48.264	51.872	Peak
Vertical	2483.5	104.632	48.264	56.368	Peak
Vertical	2483.5	73.422	31.441	41.981	Average

Note:

The Band Edge Field Strength was calculated using the Fundamental and Conducted Band Edge measurements per the Marker-Delta Method with the following formula:

Band Edge field Strength = F - Δ

F = Fundamental field Strength (Peak or Average)

Δ = Conducted Band Edge Delta (Peak or Average)

Peak limit = 74dBuV/m, Average limit = 54dBuV/m

Peak Detector of conducted Band Edge Delta

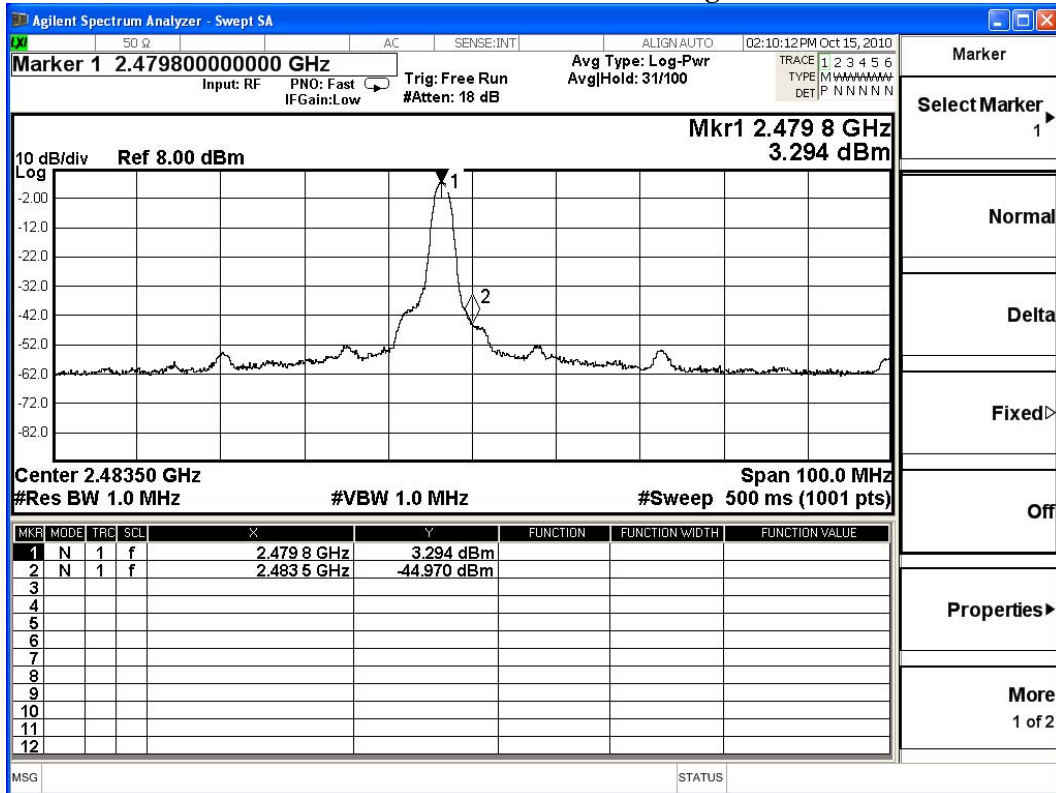

Average Detector of conducted Band Edge Delta

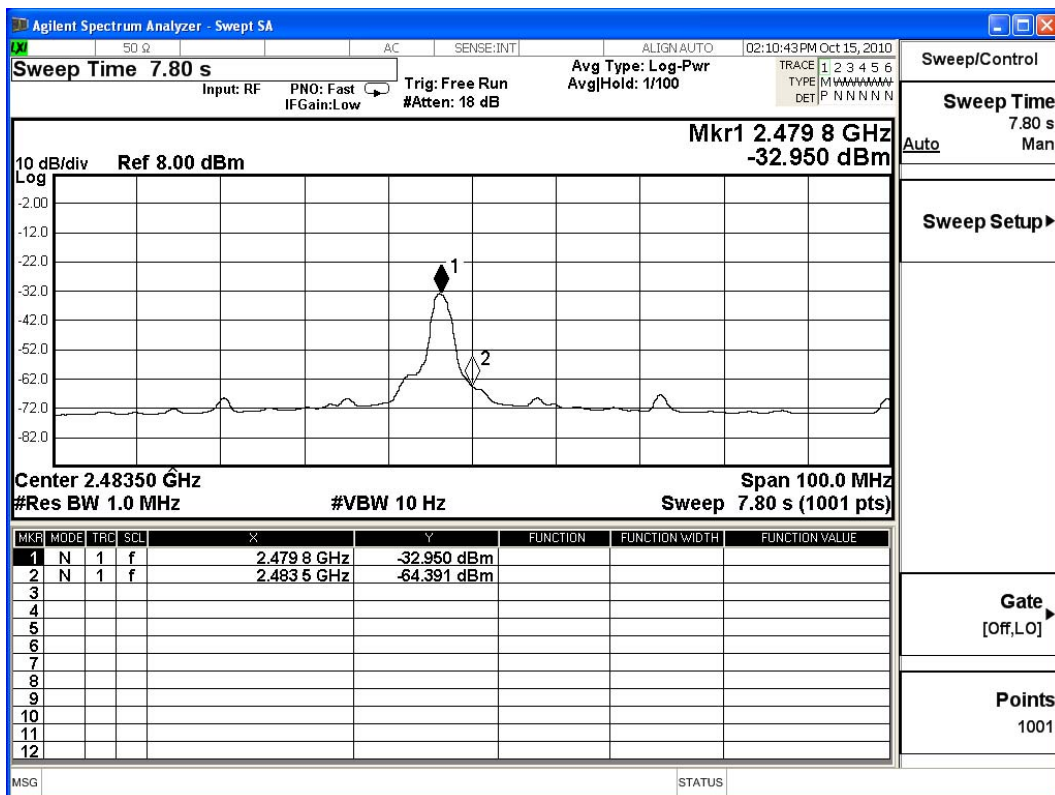

Product : S3 Compact Car SpeakerPhone
 Test Item : Band Edge
 Test Site : No.3 OATS
 Test Mode : Mode 4: Transmit - 3Mbps (8DPSK)

Fundamental Filed Strength

Antenna Pole	Frequency [MHz]	Correction Factor [dB/m]	Reading Level [dBuV]	Emission Level [dBuV/m]	Detector
Horizontal	2402	32.155	68.63	100.786	Peak
Vertical	2402	32.155	68.95	101.106	Peak

Note: 1:Spectrum Analyzer setting:

Peak detector: RBW=1MHz, VBW=1MHz

Average detector: RBW=1MHz, VBW=10Hz

Band Edge Test Data

Antenna Pole	Test Frequency (MHz)	Fundamental (dBuV/m)	Δ (dB)	Band Edge Field Strength (dBuV/m)	Detector
Horizontal	2375.8	100.786	58.065	42.721	Peak
Vertical	2375.8	101.106	58.065	43.041	Peak

Note:

The Band Edge Field Strength was calculated using the Fundamental and Conducted Band Edge measurements per the Marker-Delta Method with the following formula:

Band Edge field Strength = F - Δ

F = Fundamental field Strength (Peak or Average)

Δ = Conducted Band Edge Delta (Peak or Average)

Peak limit = 74dBuV/m, Average limit = 54dBuV/m

Peak Detector of conducted Band Edge Delta

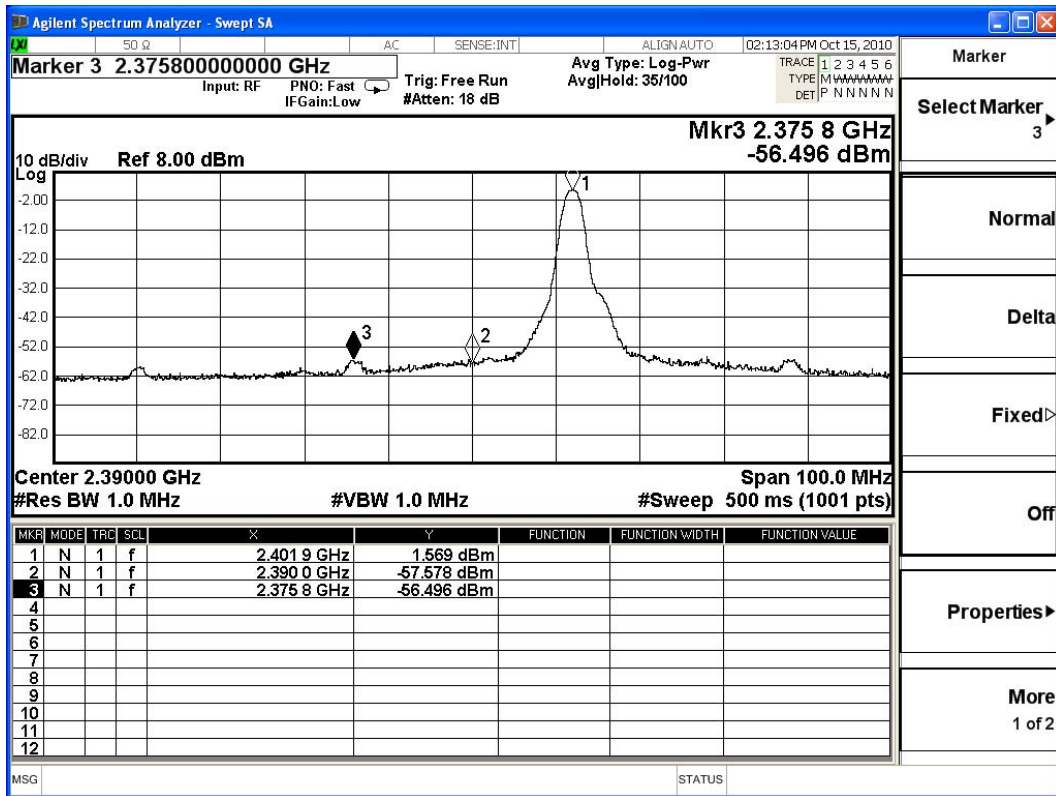

Product : S3 Compact Car SpeakerPhone
 Test Item : Band Edge
 Test Site : No.3 OATS
 Test Mode : Mode 4: Transmit - 3Mbps (8DPSK)

Fundamental Filed Strength

Antenna Pole	Frequency [MHz]	Correction Factor [dB/m]	Reading Level [dBuV]	Emission Level [dB(uV/m)]	Detector
Horizontal	2480	32.155	68.63	100.786	Peak
Vertical	2480	32.155	68.95	101.106	Peak

Note: 1:Spectrum Analyzer setting:

Peak detector: RBW=1MHz, VBW=1MHz

Average detector: RBW=1MHz, VBW=10Hz

Band Edge Test Data

Antenna Pole	Test Frequency (MHz)	Fundamental (dBuV/m)	Δ (dB)	Band Edge Field Strength (dBuV/m)	Detector
Horizontal	2483.5	100.786	49.521	51.265	Peak
Vertical	2483.5	101.106	49.521	51.585	Peak

Note:

The Band Edge Field Strength was calculated using the Fundamental and Conducted Band Edge measurements per the Marker-Delta Method with the following formula:

Band Edge field Strength = F - Δ

F = Fundamental field Strength (Peak or Average)

Δ = Conducted Band Edge Delta (Peak or Average)

Peak limit = 74dBuV/m, Average limit = 54dBuV/m

Peak Detector of conducted Band Edge Delta

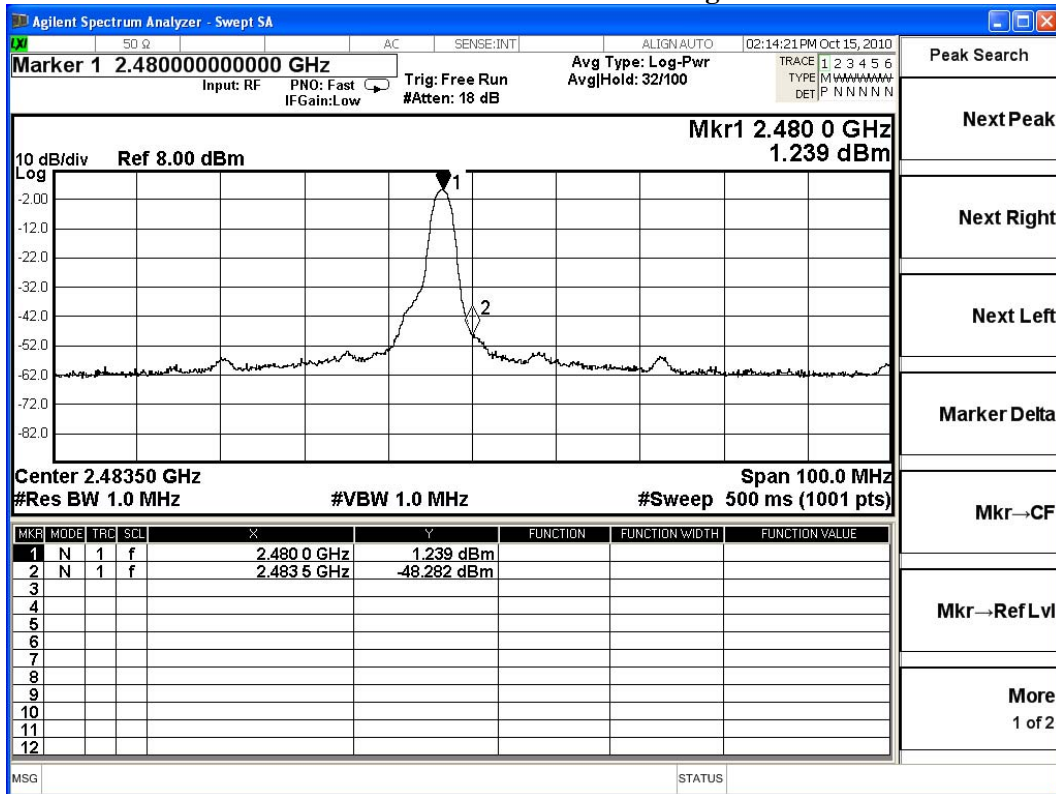

7. Channel Number

7.1. Test Equipment

	Equipment	Manufacturer	Model No./Serial No.	Last Cal.
	Spectrum Analyzer	R&S	FSP40 / 100170	Jun, 2010
	Spectrum Analyzer	Agilent	E4407B / US39440758	Jun, 2010
X	Spectrum Analyzer	Agilent	N9010A / MY48030495	Apr., 2010

Note: 1. All equipments are calibrated every one year.
 2. The test instruments marked by “X” are used to measure the final test results.

7.2. Test Setup

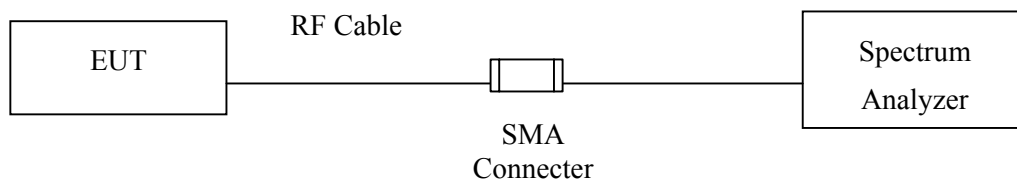

7.3. Limit

Frequency hopping systems operating in the 2400-2483.5 MHz bands shall use at least 75 hopping frequencies.

7.4. Test Procedure

The EUT was setup to ANSI C63.4, 2003; tested to FHSS test procedure of FCC Public Notice DA 00-705 for compliance to FCC 47CFR 15.247 requirements.

7.5. Uncertainty

N/A

7.6. Test Result of Channel Number

Product : S3 Compact Car SpeakerPhone
 Test Item : Channel Number
 Test Site : No.3 OATS
 Test Mode : Mode 3: Transmit - 1Mbps (GFSK)

Frequency Range (MHz)	Measurement (Hopping Channel)	Required Limit (Hopping Channel)	Result
2402 ~ 2480	79	>75	Pass

2402-2441MHz

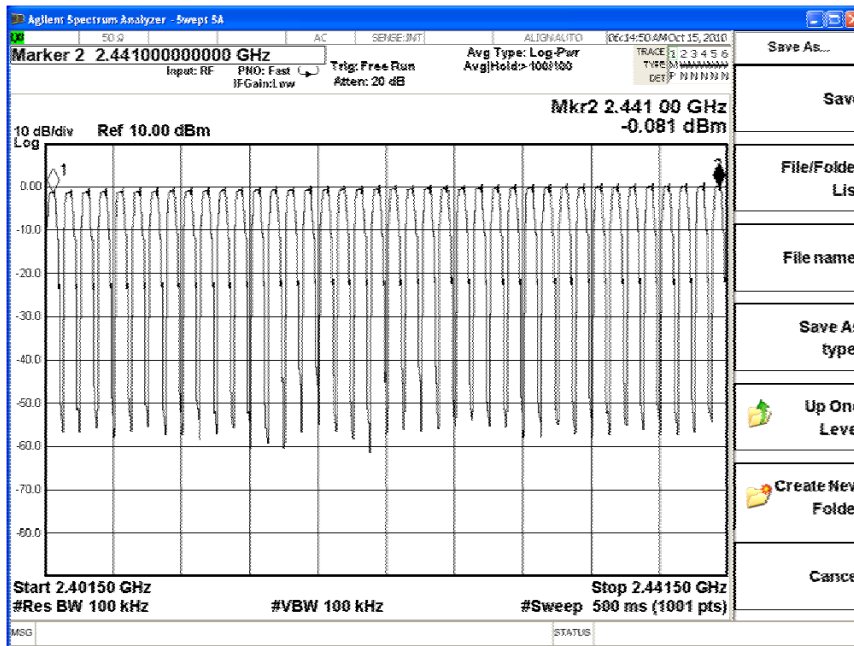

2442-2480MHz

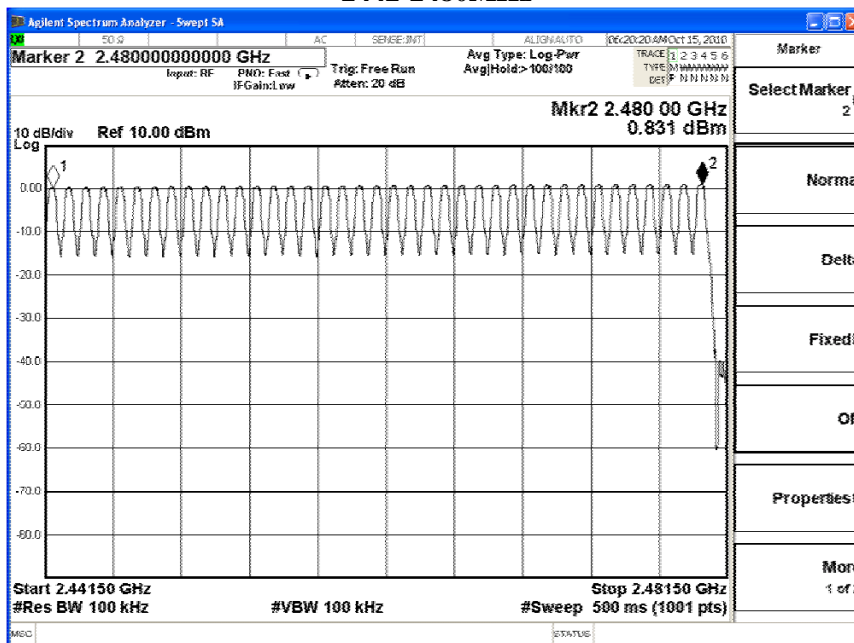

Product : S3 Compact Car SpeakerPhone
 Test Item : Channel Number
 Test Site : No.3 OATS
 Test Mode : Mode 4: Transmit - 3Mbps (8DPSK)

Frequency Range (MHz)	Measurement (Hopping Channel)	Required Limit (Hopping Channel)	Result
2402 ~ 2480	79	>75	Pass

2402-2441MHz

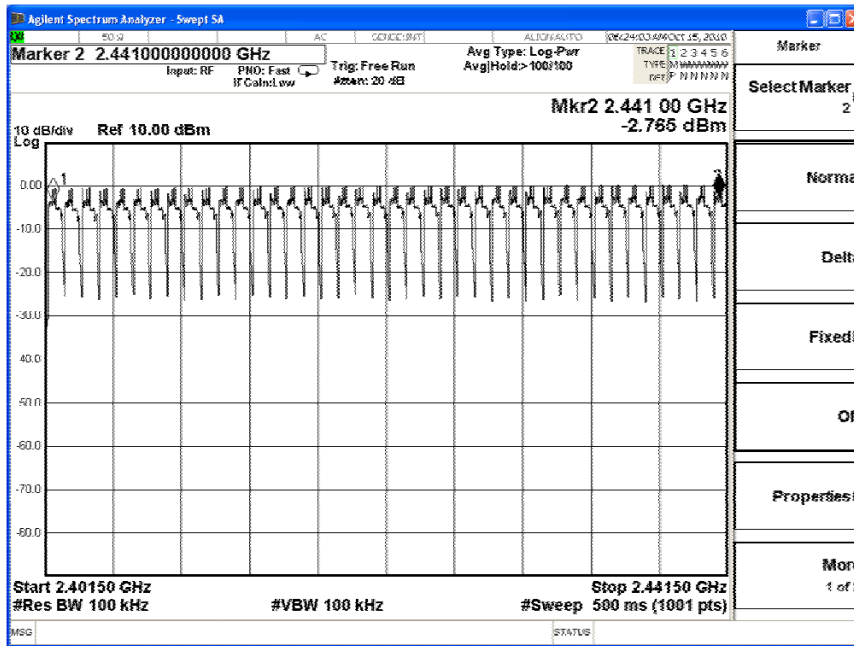

2442-2480MHz

