

Electromagnetic Emission

FCC MEASUREMENT REPORT

CERTIFICATION OF COMPLIANCE

FCC Part 15 Certification Measurement

PRODUCT : Mobile POS
MODEL/Serial No. : KDC500 / NONE
MULTIPLE MODEL : -
FCC ID : VH9KDC500
APPLICANT : AISOLUTION CO., LTD.
28-4, Samyang-ro 29-gil, Gangbuk-gu, Seoul, South Korea
Attn.: KITAE, LEE / Assistant Director
MANUFACTURER : AISOLUTION CO., LTD.
28-4, Samyang-ro 29-gil, Gangbuk-gu, Seoul, South Korea
EQUIPMENT CLASS : DXX - Part 15 Low Power Communication Device Transmitter
TYPE OF MODULATION : ASK
FREQUENCY CHANNEL : 1 CH
ANTENNA TYPE : PCB Pattern Antenna (Integral)
RULE PART(S) : FCC Part 15 Subpart C
FCC PROCEDURE : ANSI C63.10-2009
TEST REPORT No. : ETLT150819.0064
DATES OF TEST : August 26, 2015 to August 27, 2015
REPORT ISSUE DATE : September 10, 2015
TEST LABORATORY : ETL Inc. (FCC Designation Number : KR0022)

The Mobile POS, Model KDC500 has been tested in accordance with the measurement procedures specified in ANSI C63.10-2009 at the ETL Test Laboratory and has been shown to be complied with the electromagnetic radiated emission limits specified in FCC Rule Part15 Subpart C section 15.247.

I attest to the accuracy of data. All measurement herein was performed by me or was made under my supervision and is correct to the best of my knowledge and belief. I assume full responsibility for the completeness of these measurements and vouch for the qualifications of all persons taking them.

The results of testing in this report apply to the product/system which was tested only. Other similar equipment will not necessarily produce the same results due to production tolerance and measurement uncertainties.

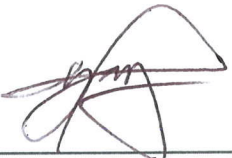
Prepared by: 
Seok Lyong, Choi (Test Engineer)
September 10, 2015

Reviewed by: 
Kug Kyoung, Yoon (Chief Engineer)
September 10, 2015

ETL Inc.

Head office: #371-51, Gasan-dong, Geumcheon-gu, Seoul, 153-803, Korea
Open site: #499-1, Sagot-ri, Seosin-myeon, Hwaseong-si, Gyeonggi-do, 445-882, Korea
Tel: 82-2-858-0786 Fax: 82-2-858-0788

Table of Contents

FCC Measurement Report

- 1. Introduction**
- 2. Product Information**
- 3. Description of Tests**
- 4. Test Condition**
- 5. Test Results**
 - 5.1 Summary of Test Results**
 - 5.2 Conducted Emissions**
 - 5.3 Radiated Emissions**
 - 5.4 13.56 MHz Carrier Field Strength within the Bands**
 - 5.5 Occupied Bandwidth**
 - 5.6 Frequency Tolerance**
- 6. Sample Calculation**
- 7. List of test Equipment used for Measurement**

FCC MEASUREMENT REPORT

Scope – Measurement and determination of electromagnetic emission (EME) of radio frequency devices including intentional radiators and/or unintentional radiators for compliance with the technical rules and regulations of the U.S Federal Communications Commission(FCC)

General Information

Applicant Name	: AISOLUTION CO., LTD.
Address	: 28-4, Samyang-ro 29-gil, Gangbuk-gu, Seoul, South Korea
Attention	: KITAE, LEE / Assistant Director

- **EUT Type** : Mobile POS
- **Model Number** : KDC500
- **S/N** : NONE
- **Freq. Range** : 13.56 MHz
- **Modulation Technique** : ASK
- **Antenna Type** : PCB Pattern Antenna (Integral)
- **Environmental of Tests** : Temperature: (26.2 ± 2.8) °C
Humidity: (52 ± 10) % R.H.
Atmospheric Pressure: (100.5 ± 0.2) kPa
- **FCC Rule Part(s)** : FCC Part 15 Subpart C
- **Test Procedure** : ANSI C63.10-2009
- **FCC Classification** : DXX - Part 15 Low Power Communication Device Transmitter
- **Place of Tests** : ETL Inc. Testing Lab. (FCC Designation Number : KR0022)

Radiated Emission test 1;
#499-1, Sagot-ri, Seosin-myeon, Hwaseong-si,
Gyeonggi-do, 445-882, Korea

Radiated Emission test 2 and Conducted Emission test;
#371-51, Gasan-dong, Geumcheon-gu, Seoul, 153-803, Korea

1. INTRODUCTION

The measurement test for radiated and conducted emission test was conducted at the ETL Inc. The site is constructed in conformance with the requirements of the ANSI C63.10-2009 and CISPR Publication 16. The ETL has site descriptions on file with the FCC for 3 m and 10 m site configurations. Detailed description of test facility was found to be in compliance with FCC Rules according to the ANSI C63.10-2009 and registered to the Federal Communications Commission (FCC Designation Number : KR0022).

The measurement procedure described in American National Standard for Method of Measurement of Radio-Noise Emission from Low-Voltage Electrical and Electronic Equipment in the Range of 9 kHz to 40 GHz (ANSI C63.10-2009) was used in determining radiated and conducted emissions from the AISOLUTION CO., LTD. Model: KDC500

2. PRODUCT INFORMATION

2.1 Equipment Description

The Equipment Under Test (EUT) is the Mobile POS (model: KDC500).

The model KDC500 is basic model that was tested.

2.2 General Specification

Item	Specification
Main Processor	120 MHz ARM Cortex-M4
Memory	1 MB program flash, 128 kB RAM, 32-byte secure key storage, 8 MB user data flash
Display	128 x 64 monochrome
Keypad	Secure Touch Pinpad (15 buttons) + 2 Scan buttons for barcode module
	'0' to '9', Up/Fn, Down/Menu, Cancel, Clear and Enter
Battery	Lithium-Ion 3.7 V DC, 4.18 Wh
Charging	Micro-USB, Charging Cradle or Wireless Charging
Mag-Stripe Reader	Track 1/2/3, Bi-directional, ISO 7810, 7811, 7813
Smart Card Reader	EMV L1 and L2, SAM
Contactless and NFC	ISO 14443, MIFARE, Felica, MasterCard PayPass, Visa PayWave
Security	PCI PTS V4
Encryption	For PIN : T-DES (128-bit)
	For Card data : T-DES (128-bit), AES (128-bit)
Key Management	DUKPT
Key Injection	Key Loader
OS compatibility	All major OS
Barcode Scanner	Optional - 1D/2D
Interfaces	Bluetooth (V2.1 + EDR, Class 2, SPP/MFi), USB to Serial (Micro USB port)
Dimensions	49 mm (W) x 117 mm (L) x 25 mm (H) (1.93" x 4.6" x 0.98")
Weight	5.6 oz (160 grams)
Drop Spec	4 feet (1.22 M)

Item	Specification
Operating Temperature	(82.5 ± 50.5) °F ((22.5 ± 22.5) °C)
Storage Temperature	(54.5 ± 58.5) °F ((12.5 ± 32.5) °C)
Humidity	(45 ± 40) % R.H. (non condensing)
NFC	ASK
	13.56 MHz
	PCB Pattern Antenna
High Internal Frequency	NFC X-tal: 27.12 MHz

3. DESCRIPTION OF TESTS

The tests documented in this report were performed in accordance with ANSI C63.10-2009 and FCC CFR 47 2.1046, 2.1047, 2.1049, 2.1051, 2.1053, 2.1055, 2.1057, 15.207, 15.209 and 15.247.

3.1 Radiated Emission Measurement

Radiated emission measurements were made in accordance with § 13 in ANSI C63.10-2009 "Measurement of Intentional radiators" The measurements were performed over the frequency range of 30 MHz to 40 GHz using antenna as the input transducer to a Spectrum analyzer or a Field Intensity Meter. The measurements were made with the detector set for "Peak, Quasi-peak, Average" within a bandwidth of 120 kHz and above 1 GHz is 1 MHz.

Preliminary measurements were made at 3 m using broadband antennas, and spectrum analyzer to determine the frequency producing the maximum emission in shielded room. Appropriate precaution was taken to ensure that all emission from the EUT were maximized and investigated. The system configuration, mode of operation, turntable azimuth and height with respect to the antenna were noted for each frequency found. The spectrum was scanned from 30 MHz to 1 000 MHz using Log-Bicon antenna. Above 1 GHz, linearly polarized double ridge horn antennas were used. Final measurements were made open site or SVSWR chamber at 3 m. The test equipment was placed on a styrofoam table. Sufficient time for the EUT, support equipment, and test equipment was allowed in order for them to warm up to their normal operating condition. Each frequency found during pre-scan measurements was re-examined by manual. The EUT, support equipment and interconnecting cables were re-configured to the set-up producing the maximum emission for the frequency and were placed on top of a 0.8 m high nonmetallic 1.0 m x 1.5 m table. The EUT, support equipment, and interconnecting cables were re-arranged and manipulated to maximize each emission. The turntable containing the system was rotated; the antenna height was varied 1 m to 4 m and stopped at the azimuth or height producing the maximum emission.

Varying the mode of operating frequencies of the EUT maximized each emission. The system was tested in all the three orthogonal planes and changing the polarity of the antenna. The worst-case emissions are recorded in the data tables. If necessary, the radiated emission measurement could be performed at a closer distance to ensure higher accuracy and the results were extrapolated to the specified distance using an inverse linear distance extrapolation factor (20 dB/decade) as per section 15.31(f).

Photographs of the worst-case emission can be seen in Photographs of the worst-case emission test setup can be seen in Appendix B.

3.1.1 Radiated Emission Limits:

(1) According to §15.209 Radiated emission limits, general requirements

(a) Except as provided elsewhere in this Subpart, the emissions from an intentional radiator shall not exceed the field strength levels specified in the following table:

Frequencies [MHz]	Field Strength [μ V/m]	Measurement Distance [m]
0.009 - 0.490	2400/F (kHz)	300
0.490 - 1.705	24000/F (kHz)	30
1.705 - 30.0	30	30
30 - 88	100**	3
88 - 216	150**	3
216 - 960	200**	3
Above 960	500	3

** Fundamental emissions from intentional radiators operating under this Section shall not be located in the frequency bands 54 MHz - 72 MHz, 76 MHz - 88 MHz, 174 MHz - 216 MHz or 470 MHz - 806 MHz. However, operation within these frequency bands is permitted under other sections of this Part, e.g., Sections 15.231 and 15.241

3.2 Carrier field strength and field strength outside 13.110 MHz - 14.010 MHz and occupied bandwidth

(1) According to §15.225 Operation within the band 13.110 MHz - 14.010 MHz

- (a) The field strength of any emissions within the band 13.553 MHz - 13.567 MHz shall not exceed 15 848 microvolts/meter at 30 meters
- (b) Within the bands 13.410 MHz - 13.553 MHz and 13.567 MHz - 13.710 MHz, the field strength of any emissions shall not exceed 334 microvolts/meter at 30 meters
- (c) Within the bands 13.110 MHz - 13.410 MHz and 13.710 MHz - 14.010 MHz, the field strength of any emissions shall not exceed 106 microvolts/meter at 30 meters
- (d) The field strength of any emissions appearing outside of the 13.110 MHz - 14.010 MHz band shall not exceed the general radiated emission limits in § 15.209

Frequency [MHz]	Field Strength Limit [μ V/m] @ 30 m	Field Strength Limit [dB(μ V/m)] @ 30 m	Field Strength Limit [dB(μ V/m)] @ 3 m
13.110 - 13.410	106	40.5	80.5
13.410 - 13.553	334	50.5	90.5
13.553 - 13.567	15 848	84.0	124.0
13.567 - 13.710	334	50.5	90.5
13.710 - 14.010	106	40.5	80.5

(2) According to §15.215(c) Occupied bandwidth

(a) Intentional radiators operating under the alternative provisions to the general emission limits, as contained in § 15.217 through 15.257 and in Subpart E of this part, must be designed to ensure that the 20 dB bandwidth of the emission, or whatever bandwidth may otherwise be specified in the specific rule section under which the equipment operates, is contained within the frequency band designated in the rule section under which the equipment is operated. The requirement to contain the designated bandwidth of the emission within the specified frequency band includes the effects from frequency sweeping, frequency hopping and other modulation techniques that may be employed as well as the frequency stability of the transmitter over expected variations in temperature and supply voltage. If frequency stability is not specified in the regulations, it is recommended that the fundamental emission be kept within at least the central 80 % of the permitted band in order to minimize the possibility of out-of-band operation.

3.3 Frequency tolerance

(1) According to §15.225 Operation within the band 13.110 MHz - 14.010 MHz

(e) The frequency tolerance of the carrier signal shall be maintained within ± 0.01 % of the operating frequency over a temperature variation of -20 °C to $+50$ °C at normal supply voltage, and for a variation in the primary supply voltage from 85 % to 115 % of the rated supply voltage at a temperature of 20 °C. For battery-operated equipment, the equipment tests shall be performed using a new battery.

3.4 Conducted Emission Measurement

Conducted emissions measurements were made in accordance with section § 13 in ANSI C63.10-2009 "measurement of intentional radiators" The measurements were performed over the frequency range of 0.15 MHz to 30 MHz using a 50 Ω /50 μ H LISN as the input transducer to a Spectrum Analyzer or a Test Receiver. The measurements were made with the detector set for "Peak" amplitude within a bandwidth of 9 kHz or for "quasi-peak" within a bandwidth of 9 kHz.

The line-conducted emission test is conducted inside a shielded anechoic chamber room with 1 m x 1.5 m x 0.8 m wooden table which is placed 0.4 m away from the vertical wall and 1.5 m away from the side wall of the chamber room. Two LISN are bonded to the shielded room. The EUT is powered from the LISN and the support equipment is powered from the other LISN. Power to the LISNs are filtered by a noise cut power line filters. If the EUT is a DC-powered device, power will be derived from the source power supply it normally will be powered from and these supply lines will be connected to the LISN. Non-inductive bundling to a 1 m length shortened all interconnecting cables more than 1 m. Sufficient time for the EUT, support equipment, and test equipment was allowed in order for them to warm up to their normal operating condition. The RF output of the LISN was connected to the EMI Test Receiver to determine the frequency producing the maximum emission from the EUT. The frequency producing the maximum level was reexamined using to set Quasi-Peak mode by manual, after scanned by automatic Peak mode from 0.15 MHz to 30 MHz. The bandwidth of the spectrum analyzer was set to 9 kHz. The EUT, support equipment, and interconnecting cables were arranged and manipulated to maximize each emission.

Photographs of the worst-case emission can be seen in Photographs of the worst-case emission test setup can be seen in Appendix B.

3.5 FCC Part 15.205 Restricted Bands of Operations

(a) Except as shown in paragraph (d) of this section, only spurious emissions are permitted in any of the frequency bands listed below:

MHz	MHz	MHz	GHz
0.090 - 0.110	16.42 - 16.423	399.9 - 410	4.5 - 5.15
¹ 0.495 - 0.505	16.694 75 - 16.695 25	608 - 614	5.35 - 5.46
2.173 5 - 2.190 5	16.804 25 - 16.804 75	960 - 1 240	7.25 - 7.75
4.125 - 4.128	25.5 - 25.67	1 300 - 1 427	8.025 - 8.5
4.177 25 - 4.177 75	37.5 - 38.25	1 435 - 1 626.5	9.0 - 9.2
4.207 25 - 4.207 75	73 - 74.6	1 645.5 - 1 646.5	9.3 - 9.5
6.215 - 6.218	74.8 - 75.2	1 660 - 1 710	10.6 - 12.7
6.267 75 - 6.268 25	108 - 121.94	1 718.8 - 1 722.2	13.25 - 13.4
6.311 75 - 6.312 25	123 - 138	2 200 - 2 300	14.47 - 14.5
8.291 - 8.294	149.9 - 150.05	2 310 - 2 390	15.35 - 16.2
8.362 - 8.366	156.524 75 - 156.525 25	2 483.5 - 2 500	17.7 - 21.4
8.376 25 - 8.386 75	156.7 - 156.9	2 690 - 2 900	22.01 - 23.12
8.414 25 - 8.414 75	162.012 5 - 167.17	3 260 - 3 267	23.6 - 24.0
12.29 - 12.293	167.72 - 173.2	3 332 - 3 339	31.2 - 31.8
12.519 75 - 12.520 25	240 - 285	3 345.8 - 3 358	36.43 - 36.5
12.576 75 - 12.577 25	322 - 335.4	3 600 - 4 400	(²)
13.36 - 13.41			

¹ Until February 1, 1999, this restricted band shall be 0.490 MHz - 0.510 MHz.

² Above 38.6

(b) Except as provided in paragraphs (d) and (e), the field strength of emissions appearing within these frequency bands shall not exceed the limits shown in Section 15.209. At frequencies equal to or less than 1 000 MHz, compliance with the limits in Section 15.209 shall be demonstrated using measurement instrumentation employing a CISPR quasi-peak detector. Above 1 000 MHz, compliance with the emission limits in Section 15.209 shall be demonstrated based on the average value of the measured emissions. The provisions in Section 15.35 apply to these measurements.

3.6 Antenna connection requirement

(1) According to §15.203

An intentional radiator shall be designed to ensure that no antenna other than that furnished by the responsible party shall be used with the device. The use of a permanently attached antenna or of an antenna that uses a unique coupling to the intentional radiator shall be considered sufficient to comply with the provisions of this Section. The manufacturer may design the unit so that a broken antenna can be replaced by the user, but the use of a standard antenna jack or electrical connector is prohibited. This requirement does not apply to carrier current devices or to devices operated under the provisions of Sections 15.211, 15.213, 15.217, 15.219, or 15.221. Further, this requirement does not apply to intentional radiators that must be professionally installed, such as perimeter protection systems and some field disturbance sensors, or to other intentional radiators which, in accordance with Section 15.31(d), must be measured at the installation site. However, the installer shall be responsible for ensuring that the proper antenna is employed so that the limits in this Part are not exceeded.

4. TEST CONDITION

4.1 Test Configuration

The device was configured for testing in a typical fashion (as a customer would normally use it). During the tests, the following conditions and configurations were used.

* This test was applied to X, Y, Z. and the worst result were investigated and reported.

4.2 Description of Test modes

Mobile POS that has the control software.

4.3 The setup drawing(s)

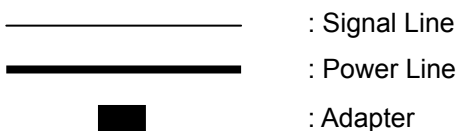
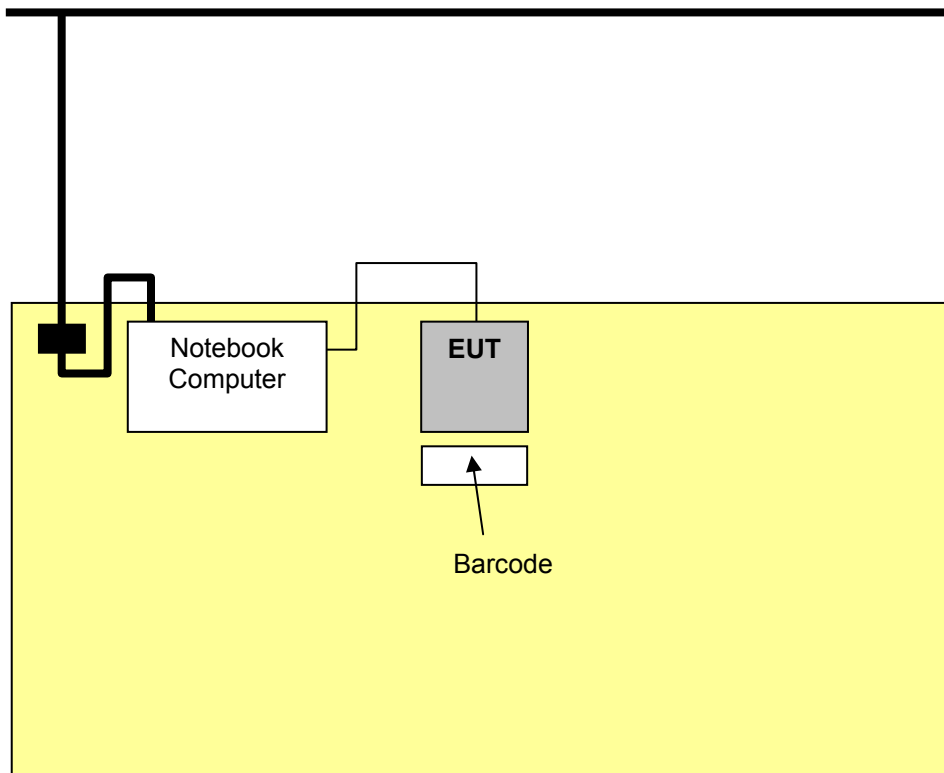

5. TEST RESULTS

5.1 Summary of Test Results

The measurement results were obtained with the EUT tested in the conditions described in this report. Detailed measurement data and plots showing the maximum emission of the EUT are reported.

Test Rule Parts	Measurement Required	Result
15.207(a),(d)	Conducted emissions	Pass *
15.209 15.225(d)	Radiated emissions Field strength outside 13.110 MHz - 14.010 MHz	Pass
15.225(a)(b)(c)	13.56 MHz carrier field strength within the bands	Pass
15.215	Occupied Bandwidth	Pass
15.225(e)	Frequency Tolerance	Pass
15.203	Antenna connection requirement	Integral antenna which is permanently attached and cannot be replaced.

** This test was tested at main host computer (EUT was connected USB port of the host computer).*

The data collected shows that the **AISOLUTION CO., LTD. / Mobile POS / KDC500** complied with technical requirements of above rules part 15.207, 209 and 15.247 Limits.

The equipment is not modified anything, mechanical or circuits to improve EMI status during a measurement. No EMI suppression device(s) was added and/or modified during testing.

5.2 Conducted Emissions Measurement

EUT	Mobile POS / KDC500 (S/N: N/A)
Limit apply to	FCC Part 15.207
Test Date	August 27, 2015
Environmental of Test	(24.3 ± 0.3) °C, (43 ± 1) % R.H., (100.5 ± 0.0) kPa
Operating Condition	RF transmitting continuously during the tested.
Result	Passed by 14.39 dB

Limit

For an intentional radiator that is designed to be connected to the public utility (AC) power line, the radio frequency voltage that is conducted back onto the AC power line on any frequency or frequencies within the band 150 kHz to 30 MHz shall not exceed the limits in the following table, as measured using a 50 μ H/50 ohms line impedance stabilization network (LISN). Compliance with the provisions of this paragraph shall be based on the measurement of the radio frequency voltage between each power line and ground at the power terminal. The lower limit applies at the boundary between the frequencies ranges.

Frequency of Emission [MHz]	Conducted limit [dB(μ V)]	
	Quasi-peak	Average
0.15 - 0.5	66 to 56 *	56 to 46 *
0.5 - 5	56	46
5 - 30	60	50

* Decreases with the logarithm of the frequency.

Test Results

- Refer to see the measured plot in next page.

Conducted Emission Test Data

The following data and graph shows the highest levels of conducted emissions on both polarizations of hot and neutral line.

Detector mode: CISPR Quasi-Peak mode (6 dB Bandwidth: 9 kHz)

NOTES:

1. Please see the measured data and graph in next page.
2. The Level (Result) value was included the reading, LISN factor and cable loss.
3. Delta(Margin) value = Limit – Level (Result)
4. If the Quasi-Peak limit is met when using a Peak detector receiver, the EUT shall be deemed to meet both limits and measurement with the Quasi-Peak detector receiver is unnecessary.
5. If the average limit is met when using a Quasi-peak detector receiver, the EUT shall be deemed to meet both limits and measurement with the average detector receiver is unnecessary.
6. Measurements were performed at the AC Power Inlet in the frequency band of 150 kHz ~ 30 MHz according to the FCC Part 15 Class B.
7. Frequency of 13.56 MHz is excluded. It is because the carrier frequency.

Line: HOT

ETL EMC Laboratory
 Conducted Emission Test Result

EUT: ETLT150819.0064
 Manuf:
 Op Cond:
 Operator:
 Test Spec:
 Comment: H

Prescan Measurement: Detectors: X PK / + AV
 Meas Time: see scan settings
 Peaks: 16
 Acc Margin: 10 dB

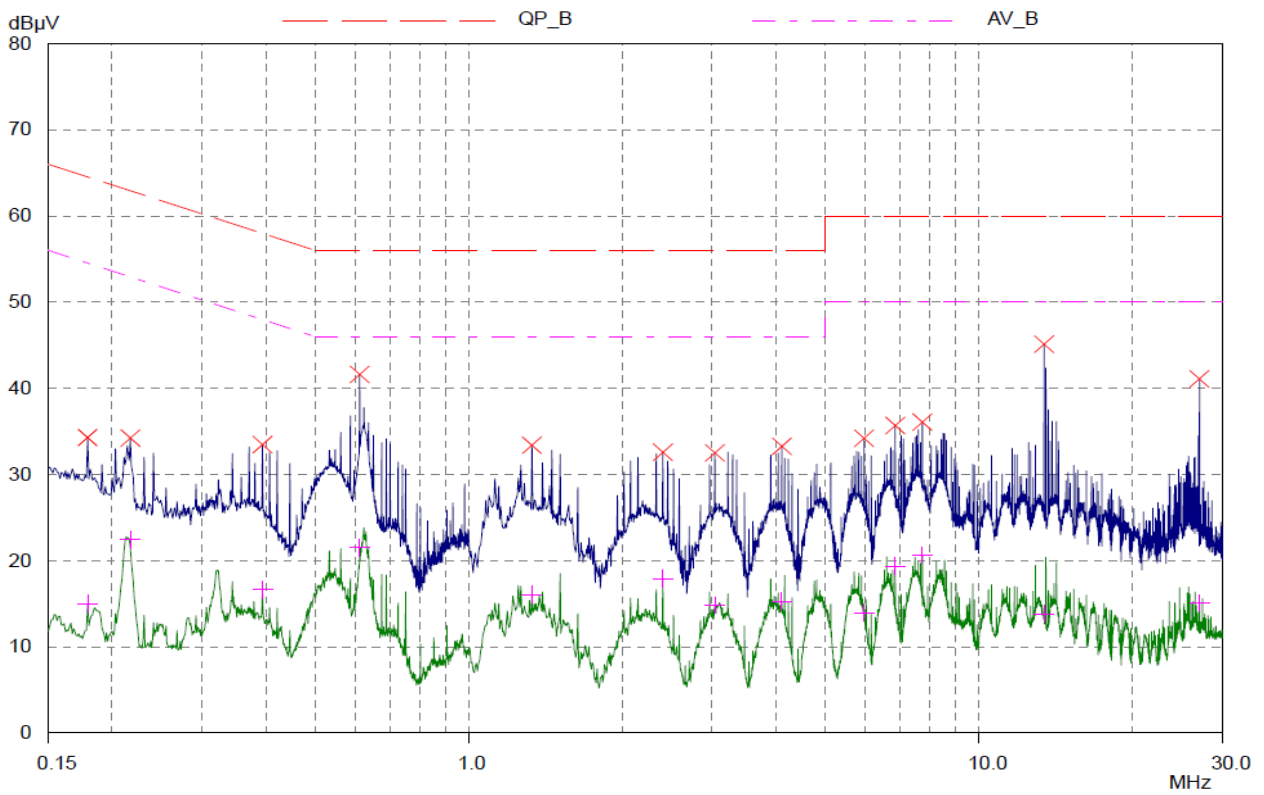

ETL EMC Laboratory

Conducted Emission Test Result

EUT: ETLT150819.0064
 Manuf:
 Op Cond:
 Operator:
 Test Spec:
 Comment: H

Prescan Measurement: Detectors: X PK / + AV
 Meas Time: see scan settings
 Peaks: 16
 Acc Margin: 10 dB

Peak Search Results

Frequency MHz	PK Level dB μ V	PK Limit dB μ V	PK Delta dB
0.179	34.29	64.53	30.24
0.217	34.22	62.93	28.71
0.394	33.46	57.98	24.52
0.611	41.61	56.00	14.39
1.33	33.38	56.00	22.62
2.4	32.57	56.00	23.43
3.035	32.50	56.00	23.50
4.105	33.27	56.00	22.73
5.955	34.21	60.00	25.79
6.85	35.67	60.00	24.33
7.745	36.06	60.00	23.94
13.41	45.12	60.00	14.88
27.05	41.09	60.00	18.91

Frequency MHz	AV Level dB μ V	AV Limit dB μ V	AV Delta dB
0.179	14.99	54.53	39.54
0.217	22.44	52.93	30.49
0.394	16.64	47.98	31.34
0.611	21.51	46.00	24.49
1.33	16.05	46.00	29.95
2.4	17.90	46.00	28.10
3.035	14.83	46.00	31.17
4.105	15.28	46.00	30.72
5.955	13.93	50.00	36.07
6.85	19.37	50.00	30.63
7.745	20.63	50.00	29.37
13.41	13.80	50.00	36.20
27.05	15.09	50.00	34.91

* limit exceeded

Line: Neutral

ETL EMC Laboratory
 Conducted Emission Test Result

EUT: ETLT150819.0064
 Manuf:
 Op Cond:
 Operator:
 Test Spec:
 Comment: N

Prescan Measurement: Detectors: X PK / + AV
 Meas Time: see scan settings
 Peaks: 16
 Acc Margin: 10 dB

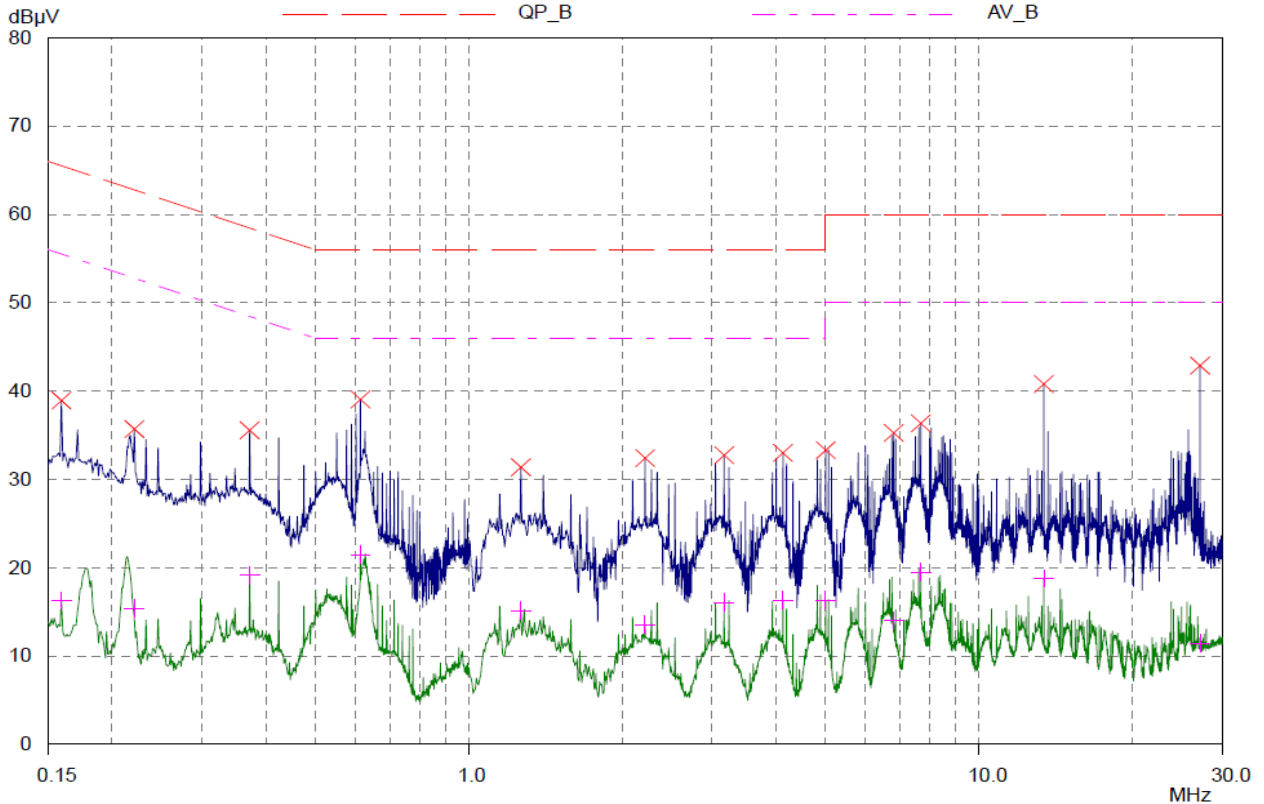

ETL EMC Laboratory

Conducted Emission Test Result

EUT: ETLT150819.0064
 Manuf:
 Op Cond:
 Operator:
 Test Spec:
 Comment: N

Prescan Measurement: Detectors: X PK / + AV
 Meas Time: see scan settings
 Peaks: 16
 Acc Margin: 10 dB

Peak Search Results

Frequency MHz	PK Level dB μ V	PK Limit dB μ V	PK Delta dB
0.159	38.93	65.52	26.59
0.221	35.70	62.78	27.08
0.372	35.56	58.46	22.90
0.613	39.05	56.00	16.95
1.265	31.36	56.00	24.64
2.215	32.41	56.00	23.59
3.165	32.73	56.00	23.27
4.13	33.00	56.00	23.00
5.005	33.30	60.00	26.70
6.805	35.26	60.00	24.74
7.69	36.35	60.00	23.65
13.4	40.80	60.00	19.20
27.11	42.87	60.00	17.13

Frequency MHz	AV Level dB μ V	AV Limit dB μ V	AV Delta dB
0.159	16.28	55.52	39.24
0.221	15.39	52.78	37.39
0.372	19.12	48.46	29.34
0.613	21.47	46.00	24.53
1.265	15.15	46.00	30.85
2.215	13.56	46.00	32.44
3.165	16.06	46.00	29.94
4.13	16.31	46.00	29.69
5.005	16.29	50.00	33.71
6.805	13.99	50.00	36.01
7.69	19.50	50.00	30.50
13.4	18.78	50.00	31.22
27.11	11.43	50.00	38.57

* limit exceeded

5.3 Spurious Emissions

EUT	Mobile POS / KDC500 (S/N: N/A)
Limit apply to	FCC Part 15.209
Operating Condition	RF transmitting continuously during the tested.
Result	Passed

Limit

Except as provided elsewhere in this Subpart, the emissions from an intentional radiator shall not exceed the field strength levels specified in the following table:

Frequencies [MHz]	Field Strength [μ V/m]	Measurement Distance [m]
0.009 - 0.490	2 400/F(kHz)	300
0.490 - 1.705	24 000/F(kHz)	30
1.705 - 30.0	30	30
30 - 88	100	3
88 - 216	150	3
216 - 960	200	3
Above 960	500	3

* Except as provided in paragraph (g), fundamental emissions from intentional radiators operating under this Section shall not be located in the frequency bands 54 MHz - 72 MHz, 76 MHz - 88 MHz, 174 MHz - 216 MHz or 470 MHz - 806 MHz. However, operation within these frequency bands is permitted under other sections of this Part, e.g., Sections 15.231 and 15.241.

Test Results

- Refer to see the measured plot in next page.

Radiated Emissions Test data

- 9 kHz to 30 MHz

Test Date	August 26, 2015
Environmental of Test	(28.7 ± 0.2) °C, (57 ± 2) % R.H., (100.5 ± 0.0) kPa

The following table shows the highest levels of radiated emissions on both polarizations of horizontal and vertical.
 Detector mode: CISPR Quasi-Peak mode (100 Hz, 9 kHz)

Frequency [MHz]	Reading [dB(μV)]	Polarization (*H/**V)	Ant. Factor [dB/m]	Cable Loss [dB]	Result [dB(μV/m)]	Limit [dB(μV/m)]	Margin [dB]
	Emission attenuated more than 20 dB below the limit are not reported.						

Result: All emissions below noise floor of 20 dB(μV/m).

NOTES:

- * H : Horizontal polarization , ** V : Vertical polarization
- Result = Reading + Antenna factor + Cable loss
- Margin = Limit - Result
- The measurement was performed for the frequency range 9 kHz to 30 MHz according to FCC Part 15.209.

- Below 1 GHz (30 MHz to 1 GHz)

Test Date	August 26, 2015
Environmental of Test	(28.7 ± 0.2) °C, (57 ± 2) % R.H., (100.5 ± 0.0) kPa

The following table shows the highest levels of radiated emissions on both polarizations of horizontal and vertical.
 Detector mode: CISPR Quasi-Peak mode (6 dB Bandwidth: 120 kHz)

Frequency [MHz]	Reading [dB(μV)]	Polarization (*H/**V)	Ant. Factor [dB/m]	Cable Loss [dB(μV)]	Height [cm]	Result [dB(μV/m)]	Limit [dB(μV/m)]	Margin [dB]
252.64	8.72	V	11.80	2.18	121	22.70	46.00	23.30
294.07	9.31	V	13.13	2.36	126	24.80	46.00	21.20

NOTES:

1. * H : Horizontal polarization , ** V : Vertical polarization
2. Result = Reading + Antenna factor + Cable loss
3. Margin value = Limit - Result
4. The measurement was performed for the frequency range above 30 MHz according to FCC Part 15.209.

5.4 13.56 MHz carrier field strength within bands

EUT	Mobile POS / KDC500 (S/N: N/A)
Limit apply to	FCC Part 15.225(a)(b)(c)
Test Date	August 26, 2015
Environmental of Test	(28.6 ± 0.3) °C, (60 ± 2) % R.H., (100.5 ± 0.1) kPa
Operating Condition	RF transmitting continuously during the tested
Result	Passed

Radiated Emission Test Data

The following table shows the highest levels of radiated emissions on both polarizations of horizontal and vertical. Detector mode: CISPR Quasi-Peak mode (6 dB Bandwidth: 9 kHz)

Frequency [MHz]	Reading [dB(μV) @ 3 m]	Polarization (*H/**V)	Ant. Factor [dB/m]	Cable Loss [dB]	Result [dB(μV/m) @ 3 m]	Limit [dB(μV/m) @ 3 m]	Margin [dB]
13.56	56.70	H	9.10	0.70	66.50	124.00	57.50

NOTES:

- * H : Horizontal polarization , ** V : Vertical polarization
- Result = Reading + Antenna factor + Cable loss
- Margin value = Limit - Result
- The measurement was performed for the frequency range 13.56 MHz according to FCC Part 15.225(a)(b)(c)

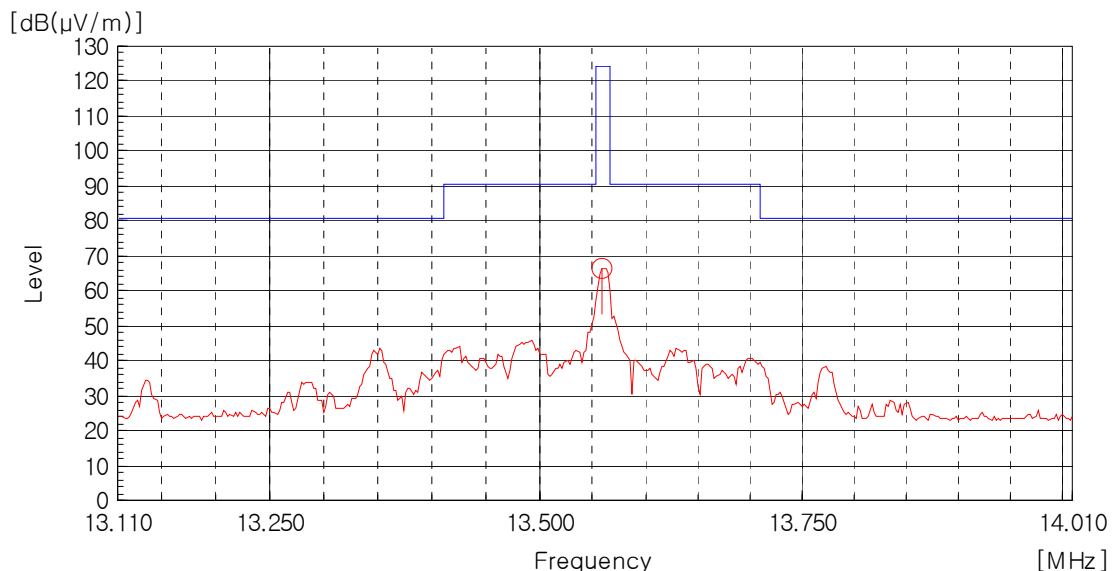

5.5 Occupied Bandwidth

EUT	Mobile POS / KDC500 (S/N: N/A)
Limit apply to	FCC Part 15.215
Test Date	August 27, 2015
Environmental of Test	(23.8 ± 0.0) °C, (48 ± 0) % R.H., (100.5 ± 0.0) kPa
Operating Condition	RF transmitting continuously during the tested.
Result	Passed

5.5.1 Occupied Bandwidth

Frequency [MHz]	20 dB Bandwidth [kHz]
13.56	8.29

NOTES:

1. Measure frequency separation of relevant channel using spectrum analyzer.

Plots of 20 dB Bandwidth

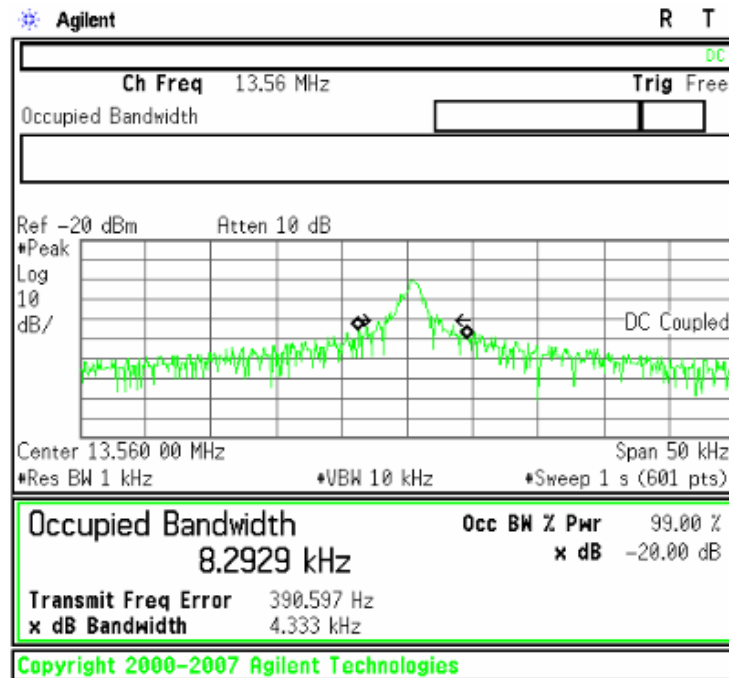

5.6 Frequency Tolerance

EUT	Mobile POS / KDC500 (S/N: N/A)
Limit apply to	FCC Part 15.215(e)
Test Date	August 27, 2015
Environmental of Test	(24.3 ± 0.9) °C, (48 ± 3) % R.H., (100.4 ± 0.1) kPa
Operating Condition	RF transmitting continuously during the tested
Result	Passed

Frequency Tolerance Test Data

The Frequency Tolerance of the carrier signal shall be maintained within ± 0.01 % of operating frequency over a temperature variation of -20 °C to +50 °C at normal supply voltage, and for a variation in the primary supply voltage from 85 % to 115 % of the rated supply voltage at a temperature of 20 °C.

- Operating frequency: 13.56 MHz
- Limit: ± 1 356 Hz
- Within the band: 13.558 644 MHz - 13.561 356 MHz

Frequency Stability Versus Environment Temperature (+50 °C ~ -20 °C)

Reference Frequency: 13.56 MHz				Limit: ± 1 356 Hz				
Environment Temperature [°C]	Frequency Measure with Time Elapsed							
	Start up		2 Minute		5 Minute		10 Minute	
	MHz	Deviation	MHz	Deviation	MHz	Deviation	MHz	Deviation
50	13.560 320	0.000 320	13.560 327	0.000 327	13.560 331	0.000 331	13.560 315	0.000 315
40	13.560 333	0.000 333	13.560 332	0.000 332	13.560 328	0.000 328	13.560 335	0.000 335
30	13.560 340	0.000 340	13.560 345	0.000 345	13.560 336	0.000 336	13.560 339	0.000 339
20	13.560 358	0.000 358	13.560 352	0.000 352	13.560 363	0.000 363	13.560 354	0.000 354
10	13.560 397	0.000 397	13.560 377	0.000 377	13.560 395	0.000 395	13.560 362	0.000 362
0	13.560 384	0.000 384	13.560 385	0.000 385	13.560 387	0.000 387	13.560 376	0.000 376
-10	13.560 413	0.000 413	13.560 402	0.000 402	13.560 411	0.000 411	13.560 398	0.000 398
-20	13.560 446	0.000 446	13.560 399	0.000 399	13.560 437	0.000 437	13.560 461	0.000 461

Frequency Stability Versus Input Power (± 15 %): Environment Temperature: 25 °C

Reference Frequency: 13.56 MHz				Limit: ± 1 356 Hz				
Power Supplied [Vdc]	Frequency Measure with Time Elapsed							
	Start up		2 Minute		5 Minute		10 Minute	
	MHz	Deviation	MHz	Deviation	MHz	Deviation	MHz	Deviation
10.80	13.560 357	0.000 357	13.560 352	0.000 352	13.560 361	0.000 361	13.560 373	0.000 373
12.00	13.560 366	0.000 366	13.560 362	0.000 362	13.560 359	0.000 359	13.560 365	0.000 365
13.20	13.560 390	0.000 390	13.560 410	0.000 410	13.560 403	0.000 403	13.560 417	0.000 417

6. SAMPLE CALCULATION

Sample Field Strength Calculation

The field strength is calculated by adding the Antenna Factor and Cable Factor.
The basic equation with a sample calculation is as follows:

$$FS = RA + AF + CF - PA$$

Where FS = Field Strength
RA = Receiver Amplitude
AF = Antenna Factor
CF = Cable Attenuation Factor
PA* = Preamplifier Factor

* PA is only be used for the measuring frequency above 1 GHz.

$$\begin{aligned} \text{dB}(\mu\text{V}) &= 20 \log_{10} (\mu\text{V}) : \text{Equation} \\ \text{dB}(\mu\text{V}) &= \text{dBm} + 107 \end{aligned}$$

Example : @ 294.07 MHz

Class B Limit	=	46.00 dB($\mu\text{V}/\text{m}$)
Reading	=	9.31 dB(μV)
Antenna Factor + (Cable Loss)	=	13.13 + 2.36 = 15.49 dB($\mu\text{V}/\text{m}$)
Total	=	24.80 dB($\mu\text{V}/\text{m}$)
Margin	=	46.00 – 24.80 = 21.20 dB
	=	21.20 dB below Limit

7. List of test equipments used for measurements

	Test Equipment	Model	Mfg.	Serial No.	Cal. Date	Cal. Due Date
<input checked="" type="checkbox"/>	EMI Test Receiver	ESVS 10	R&S	835165/001	15.03.17	16.03.17
<input checked="" type="checkbox"/>	EMI Test Receiver	ESCS30	R&S	847793/005	15.03.17	16.03.17
<input checked="" type="checkbox"/>	Two-Line V-Network	ENV216	R&S	958599/106	15.03.16	16.03.16
<input checked="" type="checkbox"/>	LISN	3816-2	EMCO	1002	15.04.22	16.04.22
<input checked="" type="checkbox"/>	Loop Antenna	6502	EMCO	00033743	14.09.23	16.09.23
<input checked="" type="checkbox"/>	LogBicon Antenna	VULB9160	Schwarzbeck	3164	15.06.08	17.06.08
<input checked="" type="checkbox"/>	DC Power Supply	E3630A	Agilent	MY40006360	15.09.04	16.09.04
<input checked="" type="checkbox"/>	Turn-Table	TT 1.35 SI	SES	-	N/A	N/A
<input checked="" type="checkbox"/>	Antenna Master	AM 4.5	SES	-	N/A	N/A
<input checked="" type="checkbox"/>	Constant TEMP.&HUMID. Chamber	PL-1KP	Tabai Espec Corp.	14006754	15.03.16	16.03.16