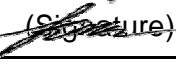

**ESTECH Co., Ltd.**Rm 1015, World Venture Center II,
426-5 Gasan-dong, Guncheon-gu,
Seoul, 158-803, Korea**Electromagnetic
Interference
Test Report**

Test Report for FCC

FCC ID:VH9-KDC300

Report Number		ESTF150903-008	
Applicant	Company name	AISOLUTION CO., LTD.	
	Address	148-3 Gwangjangdong, Gwangjingu, Seoul, 143802 korea	
	Telephone	82-2-2201-3721	
Product	Product name	Barcode Reader	
	Model No.	KDC300	Manufacturer AISOLUTION CO., LTD.
	Serial No.	NONE	Country of origin KOREA
Test date	2009-3-24 ~ 2009-3-25		Date of issue 26-Mar-09
Testing location	ESTECH. Co., Ltd. 97-1 Hoiuk-Ri Majang-Myon, Icheon-city, KyungKi-Do, Korea		
Standard	FCC PART 15 2007 , ANSI C 63.4 2003		
Measurement facility registration number	94696		
Tested by	Senior Engineer H.H.Lee		 (Signature)
Reviewed by	Engineering Manager J.M.Yang		 (Signature)
Abbreviation	OK, Pass = Passed, Fail = Failed, N/A = not applicable		

*** Note**

- This test report is not permitted to copy partly without our permission
- This test result is dependent on only equipment to be used
- This test result based on a single evaluation of one sample of the above mentioned

Contents

1. Laboratory Information	4
2. Description of EUT	5
3. Test Standards	6
4. Measurement condition	7
5. Carrier Frequency Separation	10
5.1 Test procedure	10
5.2 Test instruments and measurement setup	10
5.3 Measurement results	10
5.4 Trace data	12
6. Maximum Peak Output Power	16
7. Number of Hopping Frequency	17
7.1 Test procedure	17
7.2 Test instruments and measurement setup	17
7.3 Measurement results	17
8. Time of Occupancy (Dwell Time)	20
8.1 Test procedure	20
8.2 Test instruments and measurement setup	20
8.3 Measurement results	20
8.4 Measurement Data	21
8.5 Trace data	21

9. Band-Edge and Out of Band Emissions 25

 9.1 Test procedure 25

 9.2 Test instruments and measurement setup 25

 9.3 Measurement results 25

 9.4 Trace data of band-edge & out of emissioin 26

10. Measurement of radiated emission 36

 10.1 Measurement equipment 36

 10.2 Environmental conditions 36

 10.3 Test data 37

11. Measurement of conducted emission 52

 11.1 Measurement equipment 52

 11.2 Environmental conditions 52

 11.3 Test data 53

12. Antenna Requirement 54

 12.1 Standard Applicable 54

 12.2 Anetenna connected construction 54

Appendix 1. Spectral diagram



1. Laboratory Information

1.1 General

This EUT (Equipment Under Test) has been shown to be capable of compliance with the applicable technical standards and is tested in accordance with the measurement procedures as indicated in this report.

ESTECH Lab attests to accuracy of test data. All measurement reported herein were performed by ESTECH Co., Ltd.

ESTECH Lab assume full responsibility for the completeness of these measurements and vouch for the qualifications of all persons taking them.

1.2 Test Lab.

Corporation Name : ESTECH Co. Ltd

Head Office : Rm 1015, World Venture Center II, 426-5, Gasan-dong, Geumcheon-gu, Seoul, Korea
(Safety & Telecom. Test Lab)

EMC Test Lab : 58-1 Osan-Ri, GaNam-Myon, YeoJoo-Gun, KyungKi-Do, Korea
97-1 Hoiuk-Ri Majang-Myon, Icheon-city, KyungKi-Do, Korea

1.3 Official Qualification(s)

KCC : Granted Accreditation from Ministry of Information & Communication for EMC, Safety and Telecommunication

KOLAS : Accredited Lab By Korea Laboratory Accreditation Schema base on CENELEC requirements

FCC : Filed Laboratory at Federal Communications Commission

VCCI : Granted Accreditation from Voluntary Control Council for Interference from ITE



2. Description of EUT

2.1 Summary of Equipment Under Test (Bluetooth)

Product Name : Barcode Reader
Model Number : KDC300
Modulation Type : GFSK(FHSS) , DQPSK, 8DPSK
Transfer Rate : 3Mbps
Number of Channe: 79 ch
Serial Number : NONE
Manufacturer : AISOLUTION CO., LTD.
Country of origin : KOREA
Rating : Battery :Lithium -Polymer rechargeable(3.7V DC, 170mAh)
Receipt Date : 9-Feb-09
X-tal lists : 32.77KHz x 2, 18.32MHz

2.2 General descriptions of EUT

-Barcode Reader offers Bluetooth. The Bluetooth frequency hopping transceiver is designed to operate between 2400 and 2483.5MHz.

- the system is designed to comply with all of the regulations in Section 15.247 when the transmitter is presented with a continuous data (or information) stream. It is also comply with FHSS requirements in Section 15.247(a)(1).

: Its hopping sequence is pseudo random, all channels used equally on average. The receiver input bandwidth approximately equal the transmit band bandwidth, and its hop in sequence with the transmit signal.

- the system does not coordinate its channel selection/hopping sequence with other frequency hopping systems for the express purpose of avoiding the simultaneous occupancy of individual hopping frequencies by multiple transmitters.

3. Test Standards

Test Standard : FCC PART 15 (2007)

This Standard sets out the regulations under which an intentional, unintentional, or incidental radiator may be operated without an individual license. It also contains the technical specifications, administrative requirements and other conditions relating to the marketing of Part 15 devices.

Test Method : ANSI C 63.4 (2003)

This standard sets forth uniform methods of measurement of radio-frequency (RF) signals and noise emitted from both unintentional and intentional emitters of RF energy in the frequency range 9 kHz to 40 GHz. Methods for the measurement of radiated and AC power-line conducted radio noise are covered and may be applied to any such equipment unless otherwise specified by individual equipment requirements. These methods cover measurement of certain devices that deliberately radiate energy, such as intentional emitters, but does not cover licensed transmitters. This standard is not intended for certification/approval of avionic equipment or for industrial, scientific, and medical (ISM) equipment. These methods apply to the measurement of individual units or systems comprised of multiple units.

Summary of Test Results

Applied Standard : 47 CFR Part 15, Subpart C				
Standard	Test Type	Result	Remark	Limit
15.207	AC Power Conducted Emission	Pass	Meet the requirement	
15.209	Intentional Radiated Emission	Pass	Meet the requirement	
15.247(a)(1)	Carrier Frequency Separation & 20 Bandwidth	Pass	Meet the requirement	>25kHz
15.247(b)	Maximum Peak output power	Pass	Meet the requirement	30dBm(1W)
15.247(a)(1)(ii)	Number of Hopping Frequency	Pass	Meet the requirement	>75
15.247(c)	Transmitter Radiated Emission	Pass	Meet the requirement	
15.247(a)(1)(iii)	Time of Occupancy (Dwell Time)	Pass	Meet the requirement	<400ms
15.247(d)	Band Edge Measurement	Pass	Meet the requirement	

4. Measurement Condition

4.1 EUT Operation.

a. Channel

Ch.	Frequency	Ch.	Frequency
0	2402 MHz	40	2442 MHz
1	2403 MHz	41	2443 MHz
2	2404 MHz	42	2444 MHz
3	2405 MHz	43	2445 MHz
4	2406 MHz
...	...	78	2480 MHz
39	2441 MHz		

b. Measurement Channel : Low(2402MHz), Middle(2441MHz),High(2480MHz)

c. Test Mode : DQPSK, 8DPSK, GFSK(worst case)

d. Test rate : 3Mbps

4.2 EUT Operation.

- * The EUT was in the following operation mode during all testing
- * The operational conditions of the EUT was determined by the manufacturer according to the typical use of the EUT with respect to the expected highest level of emission
- * After setting the EUT by Zig board , tested under transmission/receiving condition continuously at specific channel frequency.

4.3 Configuration and Peripherals

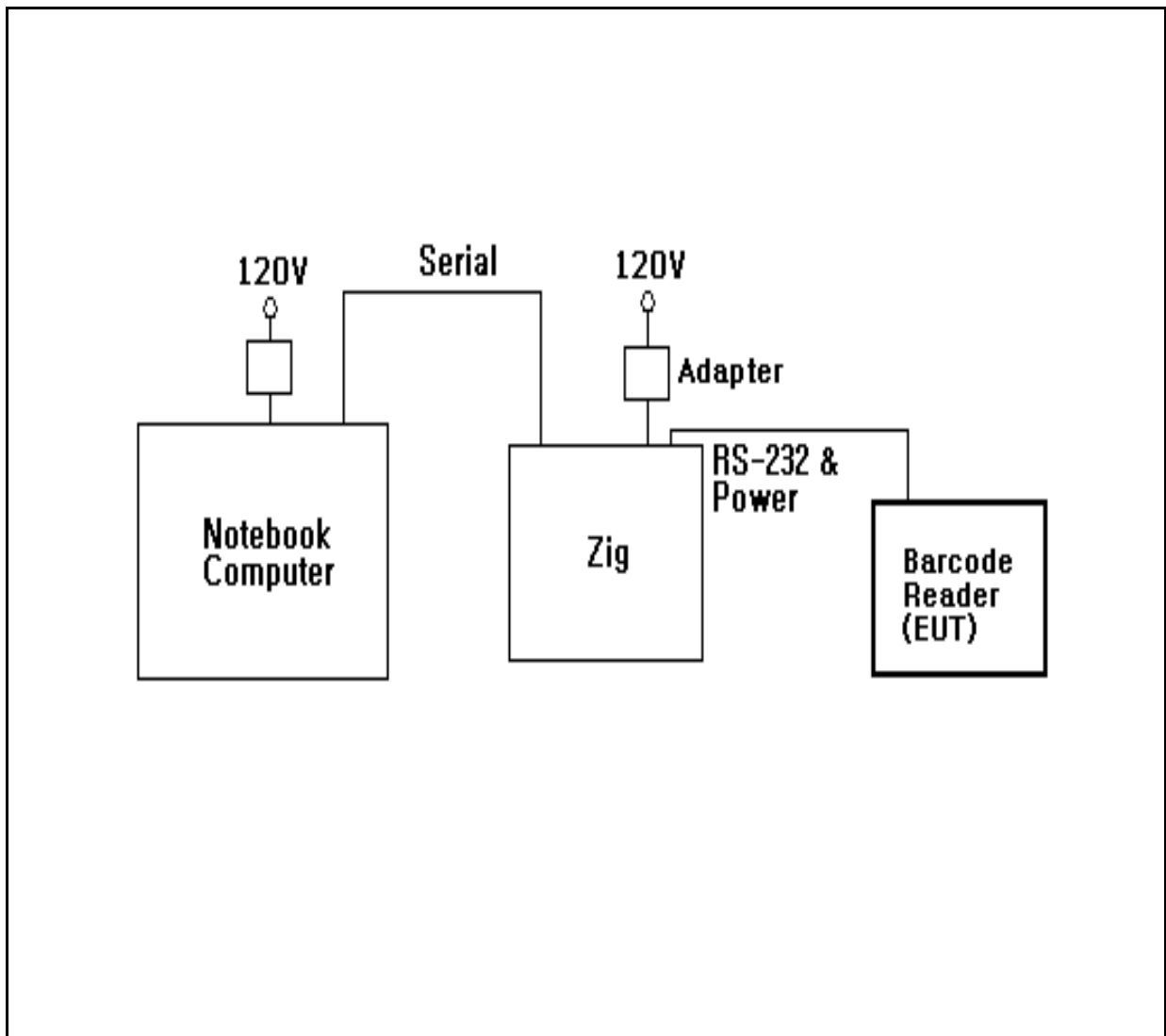

4.4 EUT and Support equipment

Equipment Name	Model Name	S/N	Manufacturer	Remark (FCC ID)
Barcode Reader	KDC300	NONE	AISOLUTION CO., LTD.	EUT
Notebook Computer	HSTNN-I05C	NONE	HEWLETT - PACKARD COMPANY	
Zig B/D	F1E21	NONE	F1 media	
Adapter	DGE -0515F	NONE	TL Electronics company	
Adapter	PPP009L	7608166702	Dongguang Lite Power 2nd Plant	

4.5 Cable Connecting

Start Equipment		End Equipment		Cable Standard		Remark
Name	I/O port	Name	I/O port	Length	Shielded	
Barcode Reader	RS - 232 & Power	Zig	RS - 232 & Power	0.3	N	
Zig	Serial	Notebook Computer	Serial	1	Y	
Zig	Power	Adapter	-	2	N	
Notebook Computer	Power	Adapter	-	2	N	

5. Carrier Frequency Separation

5.1 Test procedure

According to §15.247(a)(1), Frequency hopping systems shall have hopping channel carrier frequencies separated by minimum of 25kHz or the 20dB bandwidth of the hopping channel, whichever is greater.

5.2 Test instruments and measurement setup

The spectrum analyzer is set to as following.

- . RBW= 300KHz
- . VBW= 300KHz
- . Span= 3MHz
- . Sweep= suitable duration based on the EUT specification.

20dB Bandwidth Test Instruments

Description	Model	Serial Number	Cal. Due Date
Spectrum Analyzer	E4407B	US42041281	2009-09-11
Bluetooth Tester	TC-3000A	3000A570224	2009-12-15
-Spectrum Analyzer <=> EUT	Loss: 1.0dB	-	2010-02-26

5.3 Measurement results

EUT	Bluetooth	MODEL	KDC300
MODE	FHSS	ENVIRONMENTAL CONDITION	25 , 43%RH
INPUT POWER	DC3.7V		

(GFSK)

CHANNEL	Channel Frequency (MHz)	Bandwidth at 20dB below(kHz)	Channel Separation (MHz)	Limit (kHz)	PASS/FAIL
0	2402	929	-	-	-
39	2441	963	1.0	>25	PASS
78	2480	960	-	-	-

	ESTECH Co., Ltd.	Rm 1015, World Venture Center II, 426-5 Gasan-dong, Guncheon-gu, Seoul, 158-803, Korea	   	Electromagnetic Interference Test Report
---	-------------------------	--	--	---

(8DPSK)

CHANNEL	Channel Frequency (MHz)	Bandwidth at 20dB below(MHz)	Channel Separation (MHz)	Limit (kHz)	PASS/FAIL
0	2402	1.257	-	-	-
39	2441	1.347	1.0	>25	PASS
78	2480	1.267	-	-	-



ESTECH Co., Ltd.

1015, World Venture Center 11,
426-5 Gasan-dong, Guncheon-gu,
Seoul, 158-803, Korea



**Electromagnetic
Interference
Test Report**

5.4 Trace data (GFSK)

Channel Separation

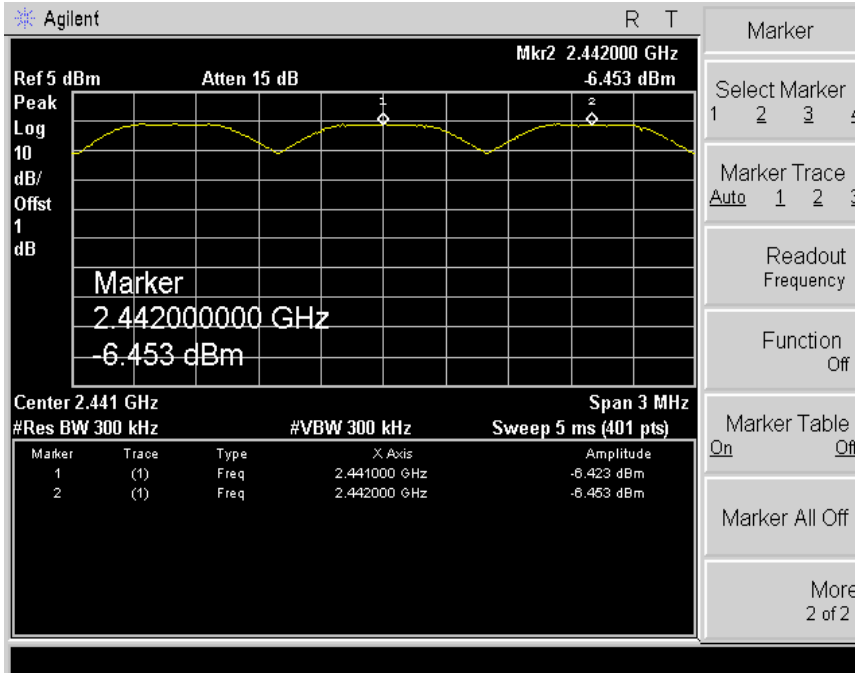

20dB bandwidth(Ch 0)

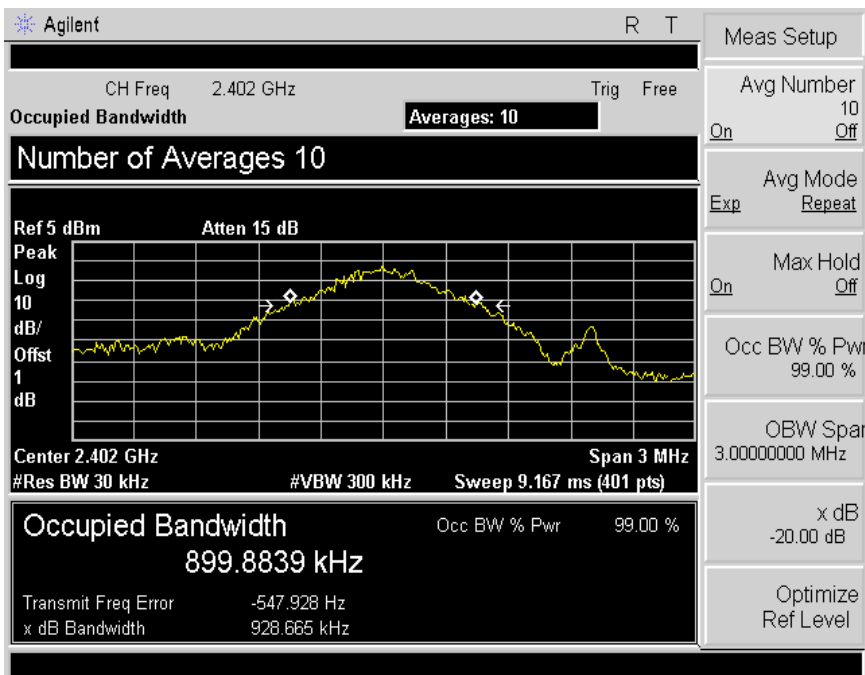



ESTECH Co., Ltd.

1015, World Venture Center 11,
426-5 Gasan-dong, Guncheon-gu,
Seoul, 158-803, Korea



**Electromagnetic
Interference
Test Report**

20dB bandwidth(CH 39)

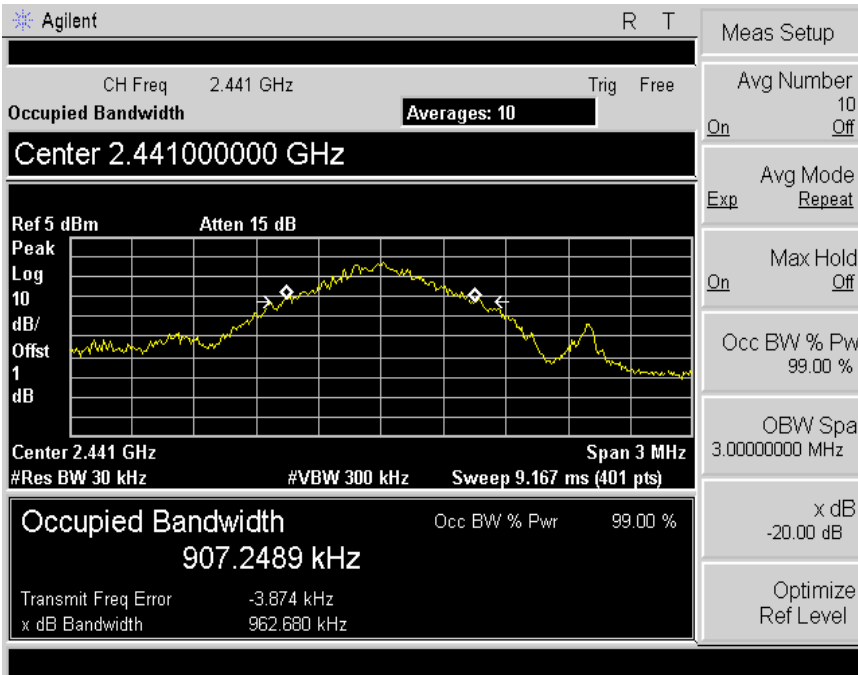

20dB bandwidth(CH 78)

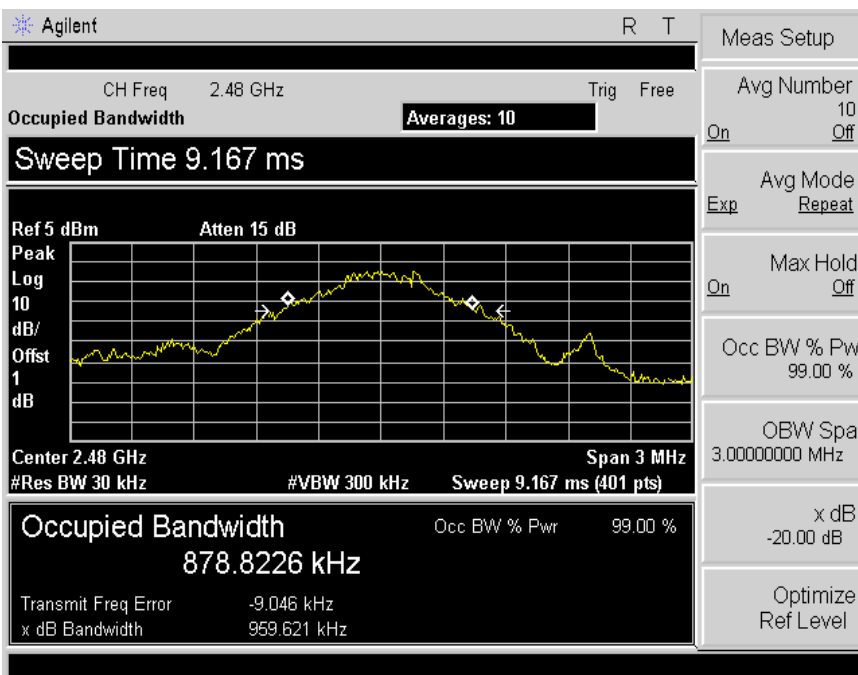



ESTECH Co., Ltd.

1015, World Venture Center 11,
426-5 Gasan-dong, Guncheon-gu,
Seoul, 158-803, Korea



**Electromagnetic
Interference
Test Report**

(8DPSK)

Channel Separation

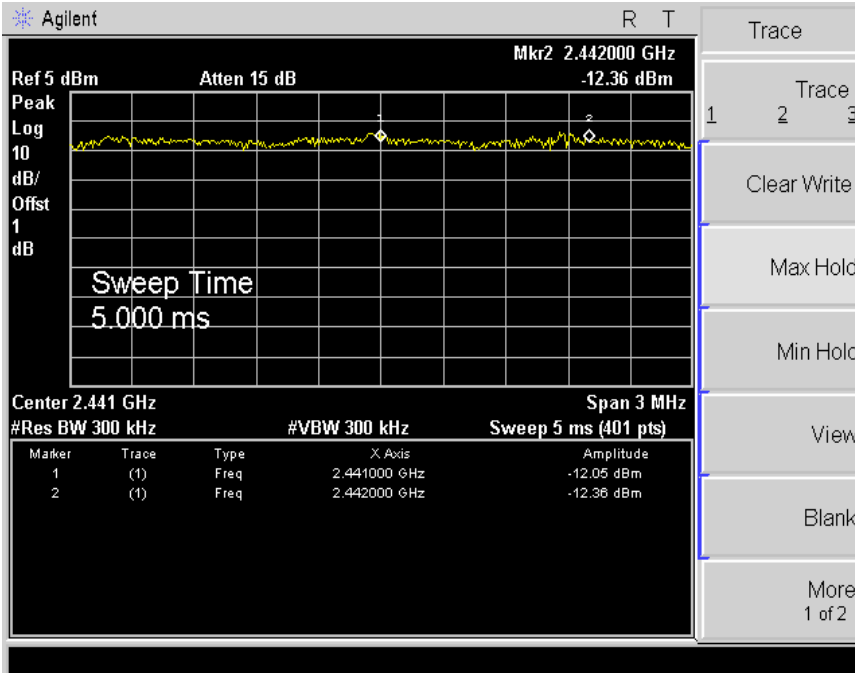

20dB bandwidth(Ch 0)

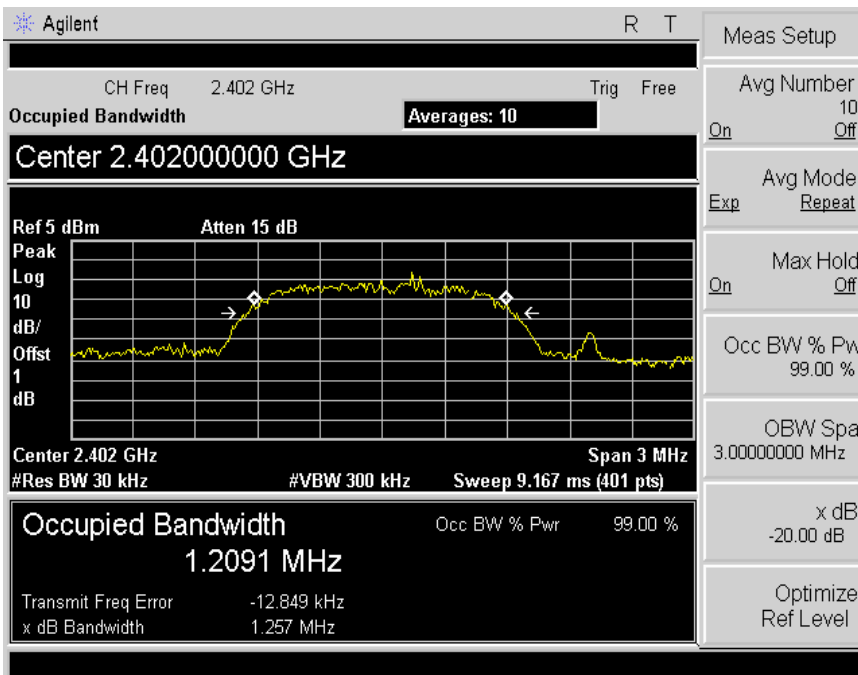



ESTECH Co., Ltd.

1015, World Venture Center 11,
426-5 Gasan-dong, Guncheon-gu,
Seoul, 158-803, Korea



**Electromagnetic
Interference
Test Report**

20dB bandwidth(CH 39)

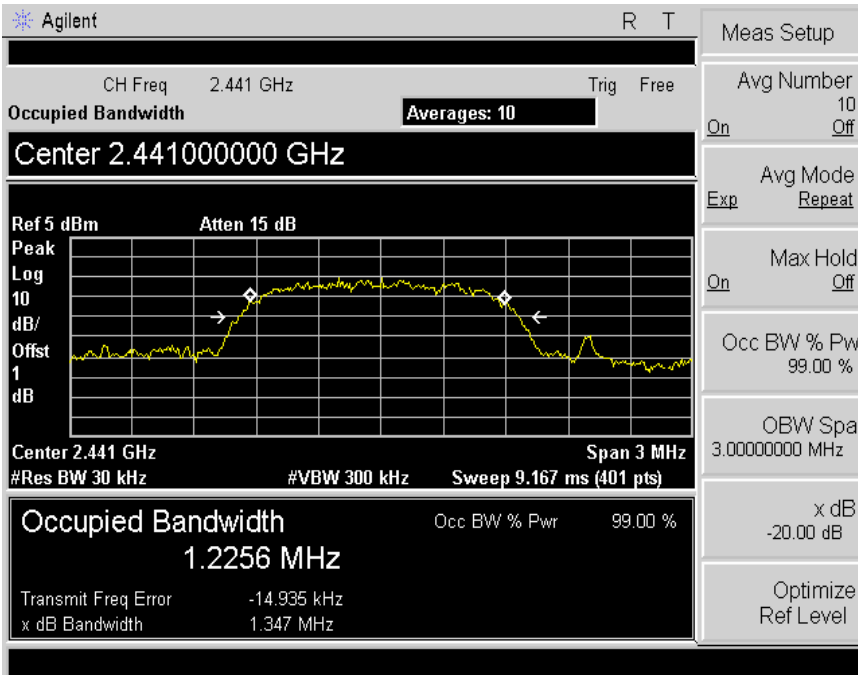

20dB bandwidth(CH 78)



6. MAXIMUM PEAK OUTPUT POWER

6.1 Test procedure

The transmitter antenna terminal is connected to the input of a RF power sensor. Measurement is made while EUT is operating in transmission mode at the appropriate center frequency. The maximum peak output power measurement is 30dBm.

Description	Model	Serial Number	Cal. Due Date
Power Meter	EPM-442A	GB37170412	2009-10-13
Power Sensor	8481A	3318A96476	2009-10-13
RF Cable:	Length:20cm	-	

6.2 Measurement results

EUT	Bluetooth	MODEL	KDC300
MODE	GFSK,8DPSK DH5	ENVIRONMENTAL CONDITION	24 , 43%RH
INPUT POWER	DC3.7V		

GFSK

CHANNEL	Channel Frequency (MHz)	Peak Power Output(dBm)		Limit[1W] (dBm)	PASS/ FAIL
		(dBm)	(W)		
0	2402	-6.40	0.0002	30.0	PASS
39	2441	-6.00	0.0003	30.0	PASS
78	2480	-6.92	0.0002	30.0	PASS

8DPSK

CHANNEL	Channel Frequency (MHz)	Peak Power Output(dBm)		Limit[1W] (dBm)	PASS/ FAIL
		(dBm)	(W)		
0	2402	-7.89	0.0002	30.0	PASS
39	2441	-8.89	0.0001	30.0	PASS
78	2480	-10.61	0.0001	30.0	PASS

Note:GFSK mode is max power in three different modulations.

7. Number of Hopping Frequency

7.1 Test procedure

According to §15.247(a)(1)(ii), Frequency hopping systems operating in the 2400MHz-2483.5MHz bands shall use at least 75 hopping frequencies.

7.2 Test instruments and measurement setup

The spectrum analyzer is set to as following.

- . RBW= 300KHz
- . VBW= 300KHz
- . Span= the frequency band of operation
- . Sweep= suitable duration based on the EUT specification.

The Number of Hopping Frequency Test Instruments

Description	Model	Serial Number	Cal. Due Date
Spectrum Analyzer	E4407B	US42041281	2009-09-11
Bluetooth Tester	TC-3000A	3000A570224	2009-12-15
Dual Directional Coupler	778D	16502	2010-02-26
-Spectrum Analyzer <=> EUT	Loss: 1.0dB		

7.3 Measurement results

EUT	Bluetooth	MODEL	KDC300
MODE	FHSS	ENVIRONMENTAL CONDITION	24 , 45%RH
INPUT POWER	DC3.7V		
Number of CH	Limit (Number of CH)	PASS/FAIL	
79	>75	PASS	



ESTECH Co., Ltd.

Rm 1015, World Venture Center II,
426-5 Gasan-dong, Guncheon-gu,
Seoul, 158-803, Korea



**Electromagnetic
Interference
Test Report**

7.4 Trace data

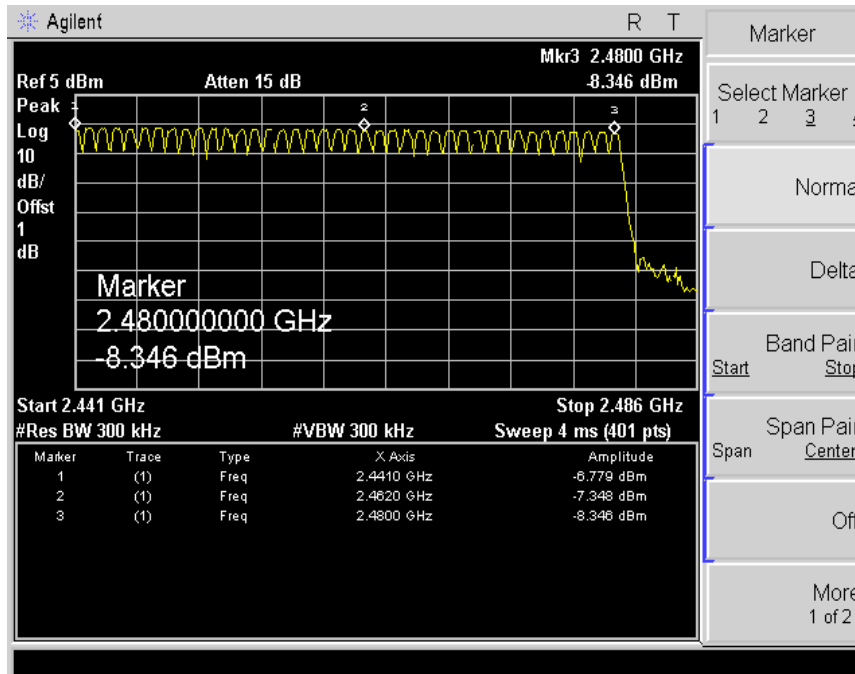
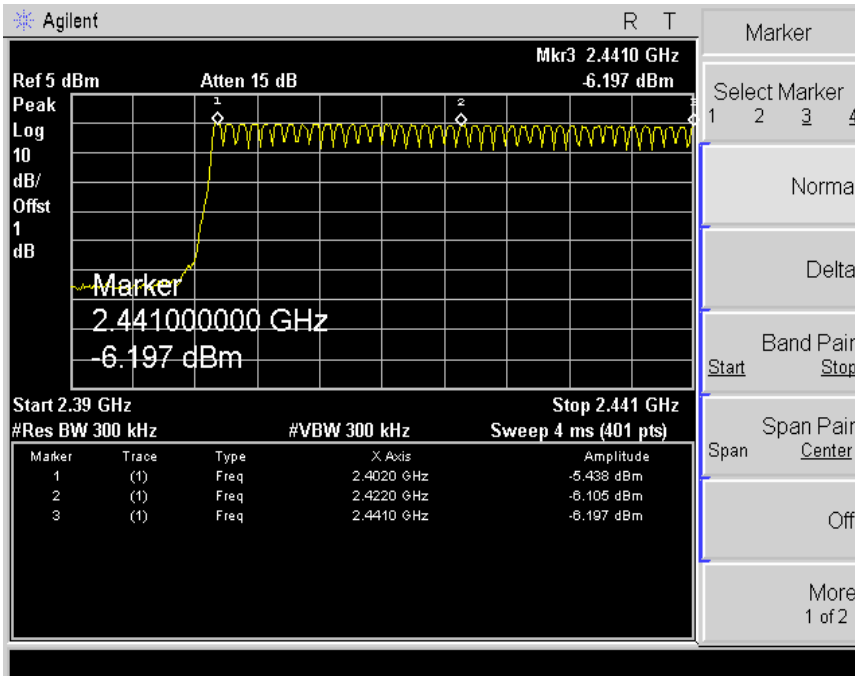



ESTECH Co., Ltd.

Rm 1015, World Venture Center II,
426-5 Gasan-dong, Guncheon-gu,
Seoul, 158-803, Korea



**Electromagnetic
Interference
Test Report**

7.4 Trace data

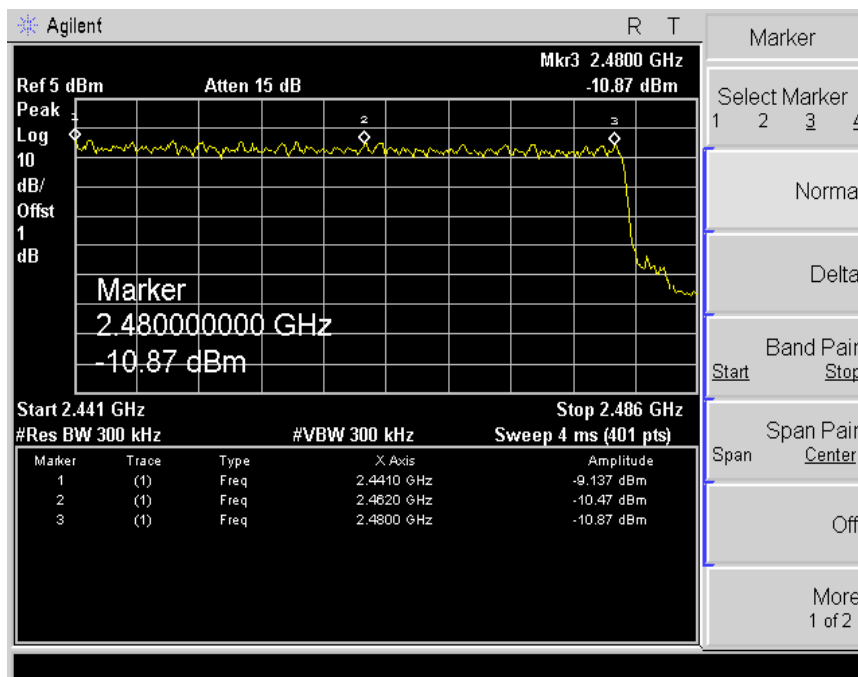
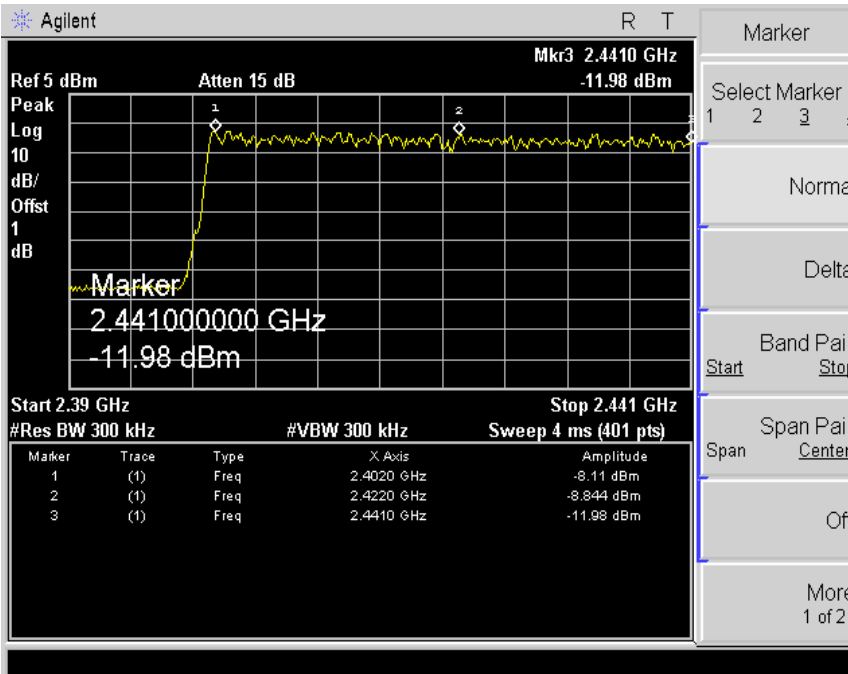

8. Time of Occupancy (Dwell Time)

8.1 Test procedure

According to §15.247(a)(1)(iii), Frequency hopping systems operating in the 2400MHz-2483.5 MHz bands. The average time of occupancy on any channels shall not greater than 0.4 s within a period 0.4 s multiplied by the number of hopping channels employed.

8.2 Test instruments and measurement setup

The spectrum analyzer is set to as following.

- . RBW= 1MHz
- . VBW 1MHz
- . Span= zero span, centered on a hopping channel
- . Sweep= as necessary to capture the entire dwell time per hopping channel

The Time of Occupancy Test Instruments

Description	Model	Serial Number	Cal. Due Date
Spectrum Analyzer	E4407B	US42041281	2009-09-11
Dual Directional Coupler	778D	16502	2010-02-26
-Spectrum Analyzer <=> EUT	Loss: 1.0dB	-	

8.3 Measurement results

EUT	Bluetooth	MODEL	KDC300
MODE	FHSS	ENVIRONMENTAL CONDITION	25 , 43%RH
INPUT POWER	DC3.7V		

8.4 Measurement Data

A. DH1 Mode

One period for each particular channel : $0.396 \text{ ms} \times 320.1 = 126.76 \text{ ms}$

Channel	Pulse Time(ms)	Limit (ms)	PASS/FAIL
39	0.396	400	PASS

B. DH3 Mode

One period for each particular channel : $1.639 \text{ ms} \times 159.9 = 262.020 \text{ ms}$

Channel	Pulse Time(ms)	Limit (ms)	PASS/FAIL
39	1.639	400	PASS

C. DH5 Mode

One period for each particular channel : $2.900 \text{ ms} \times 106.81 = 309.704 \text{ ms}$

Channel	Pulse Time(ms)	Limit (ms)	PASS/FAIL
39	2.900	400	PASS

8.5 Trace data

DH1

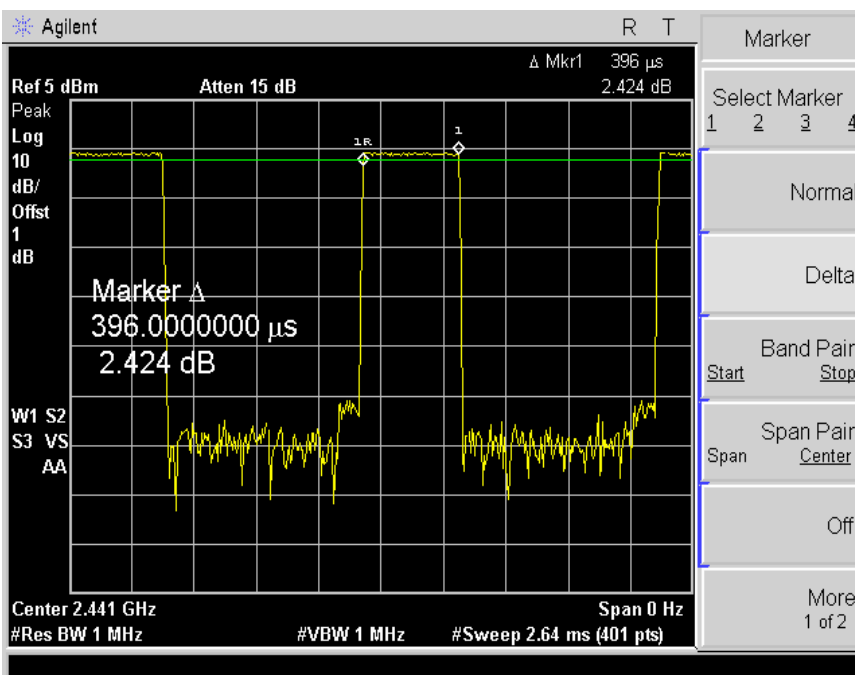



ESTECH Co., Ltd.

Rm 1015, World Venture Center II,
426-5 Gasan-dong, Guncheon-gu,
Seoul, 158-803, Korea



**Electromagnetic
Interference
Test Report**

8.4 Trace data

DH3

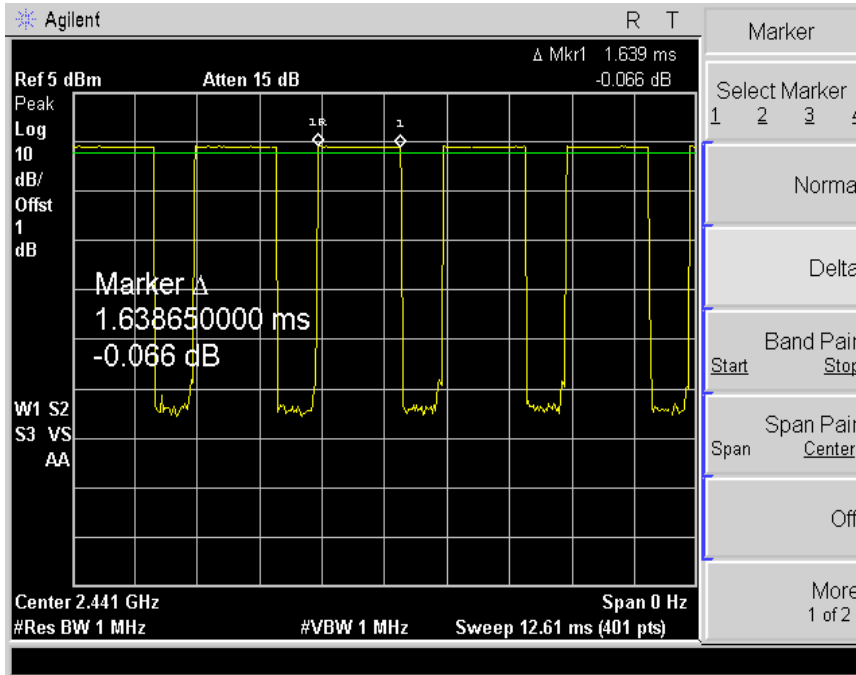

DH5

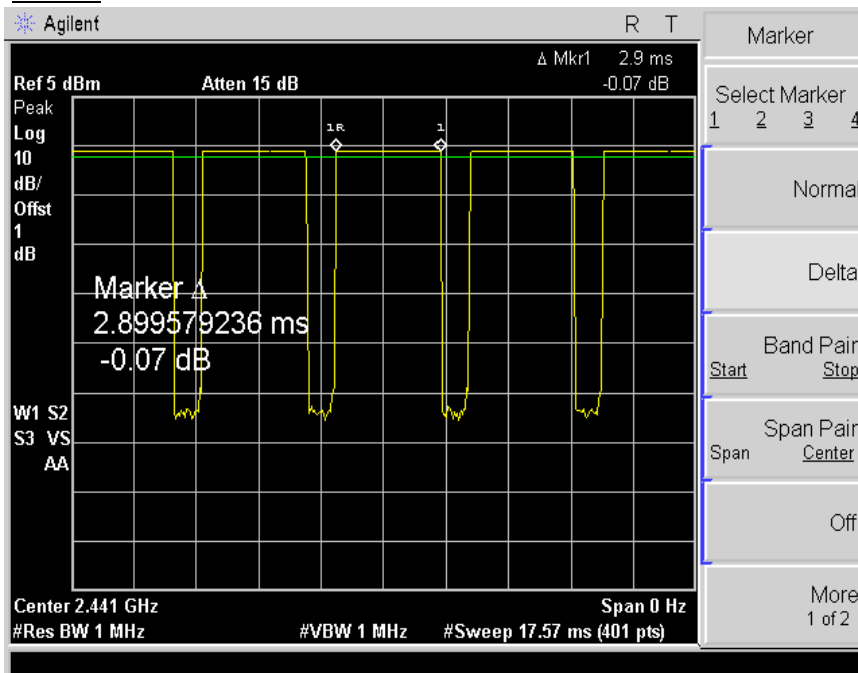

8DPSK

A. DH1 Mode

One period for each particular channel : $0.403 \text{ ms} \times 320.1 = 129.0 \text{ ms}$

Channel	Pulse Time(ms)	Limit (ms)	PASS/FAIL
39	137.9	400	PASS

B. DH3 Mode

One period for each particular channel : $1.657 \text{ ms} \times 159.9 = 265.0 \text{ ms}$

Channel	Pulse Time(ms)	Limit (ms)	PASS/FAIL
39	278.7	400	PASS

C. DH5 Mode

One period for each particular channel : $2.931 \text{ ms} \times 106.81 = 313.1 \text{ ms}$

Channel	Pulse Time(ms)	Limit (ms)	PASS/FAIL
39	328.1	400	PASS

8.5 Trace data

DH1

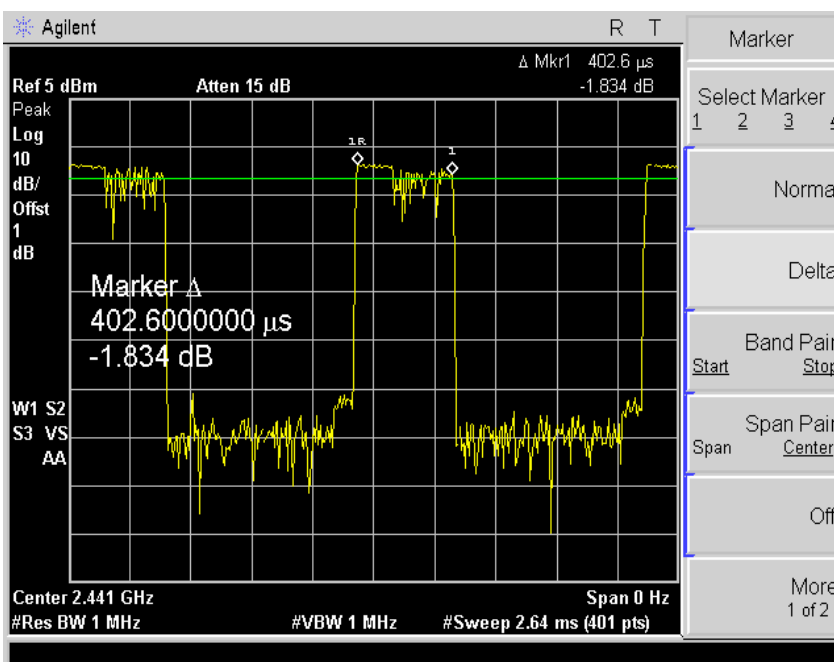



ESTECH Co., Ltd.

Rm 1015, World Venture Center II,
426-5 Gasan-dong, Guncheon-gu,
Seoul, 158-803, Korea



**Electromagnetic
Interference
Test Report**

8DPSK

DH3

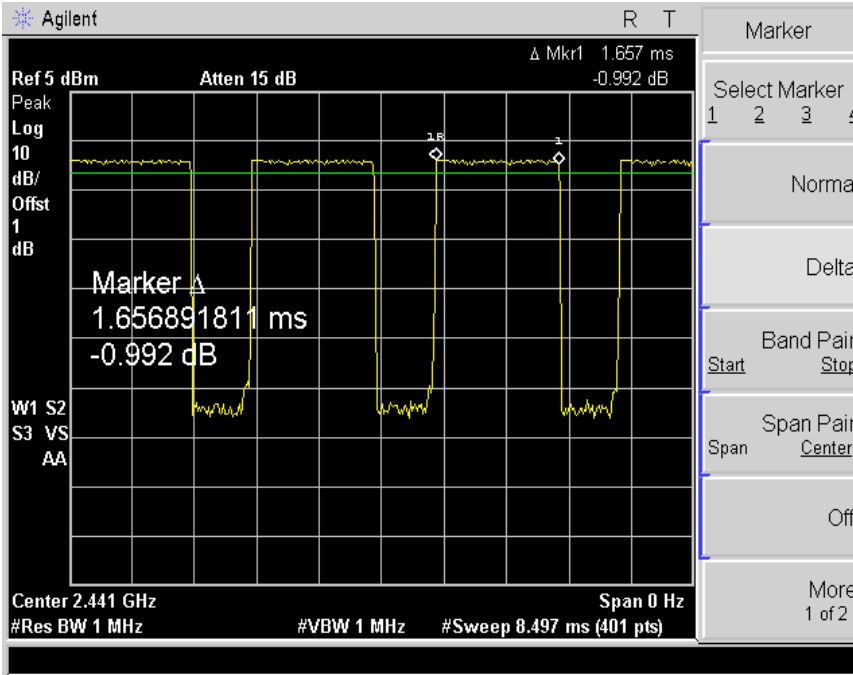

DH5

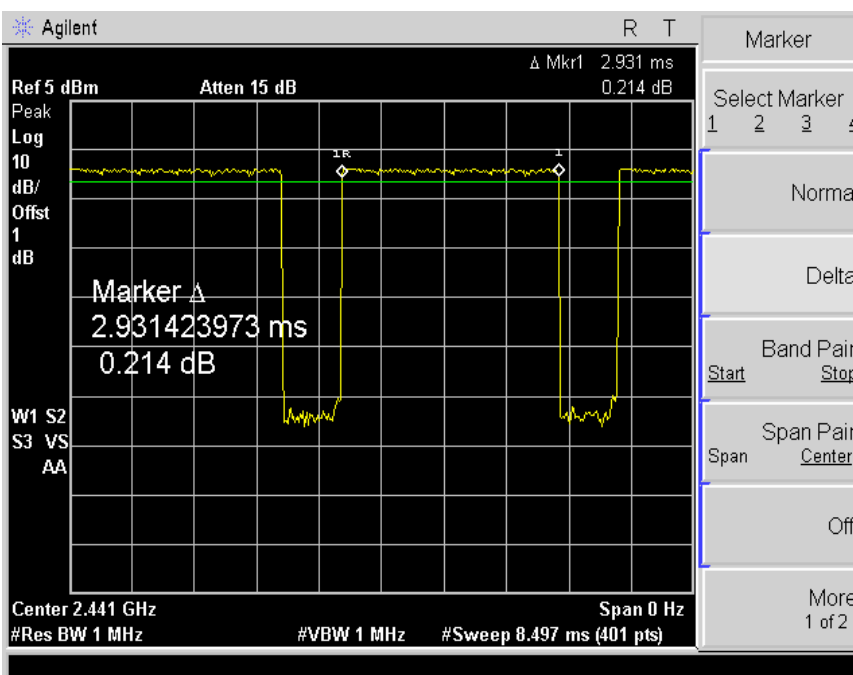

9. band-edge and out of band emissions.

9.1 Test procedure

The radio frequency power at 20dB down from the highest inband power level is measured with a spectrum analyzer connected to the antenna terminal, while EUT is operating in transmission mode at the appropriate center frequency. The band edge&out of band emission shall be at least 20dB below of the highest inband power level.

9.2 Test instruments and measurement setup

The spectrum analyzer is set to as following.

- . RBW= 100KHz
- . VBW= 100KHz
- . Span= suitable frequency span
- . Sweep= suitable duration based on the EUT specification.

Band Edge&Out of Emission Test Instruments

Description	Model	Serial Number	Cal. Due Date
Spectrum Analyzer	E4407B	US42041281	2009-09-11
Bluetooth Tester	TC-3000A	3000A570224	2009-12-15
-Spectrum Analyzer <=> EUT	Loss: 1.0dB		

9.3 Measurement results of band-edge & out of emission

EUT	Bluetooth	MODEL	KDC300
MODE	GFSK	ENVIRONMENTAL CONDITION	24 , 44%RH
INPUT POWER	DC 3.7V		

* Refer to attach spectrum analyzer data chart.



ESTECH Co., Ltd.

Rm 1015, World Venture Center 11,
426-5 Gasan-dong, Guncheon-gu,
Seoul, 158-803, Korea



**Electromagnetic
Interference
Test Report**

9.4 Trace data of band-edge & Out of Emission CH 0

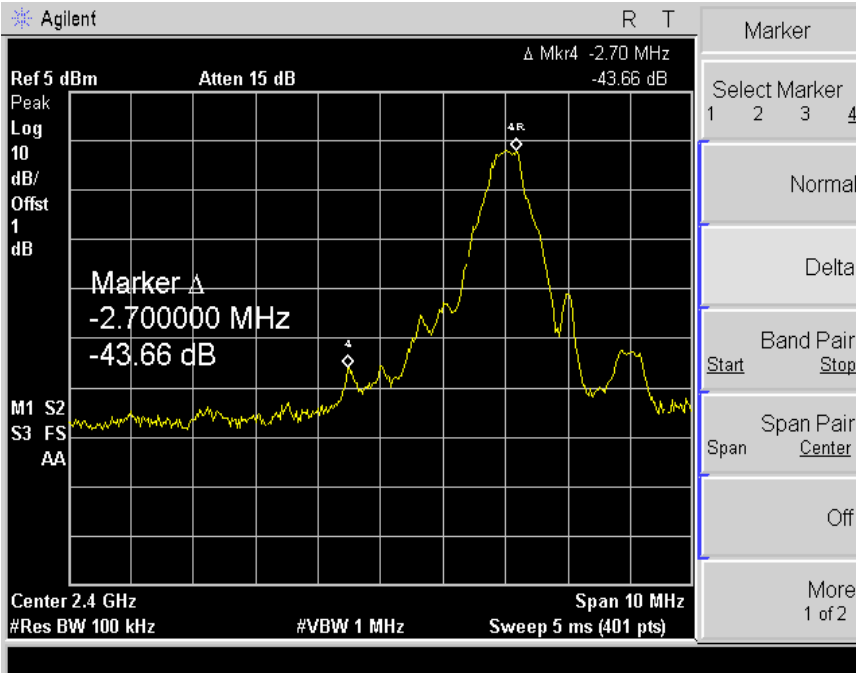

CH78

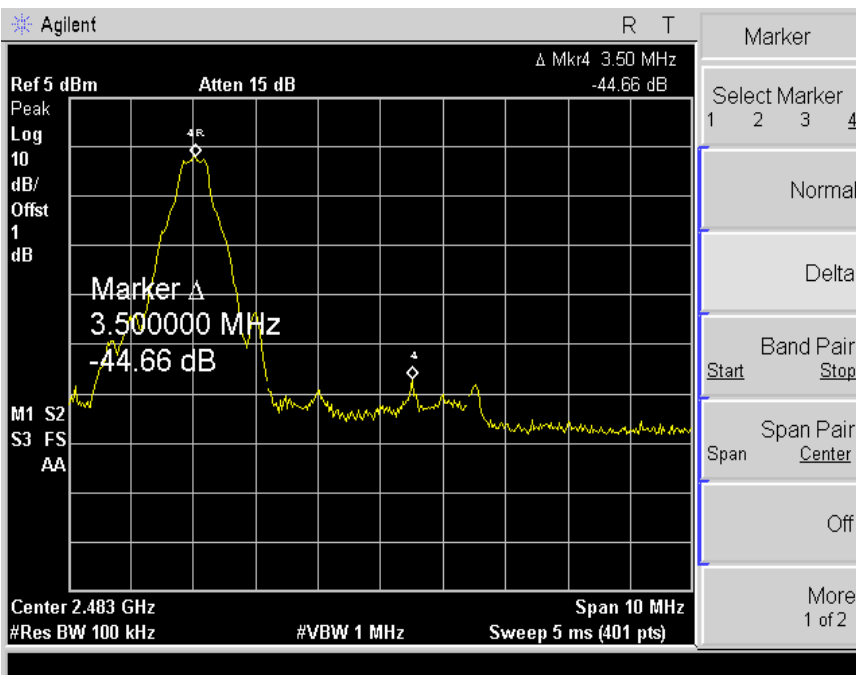



ESTECH Co., Ltd.

Rm 1015, World Venture Center 11,
426-5 Gasan-dong, Guncheon-gu,
Seoul, 158-803, Korea

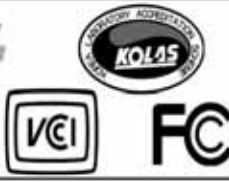

**Electromagnetic
Interference
Test Report**

Hopping on CH 0

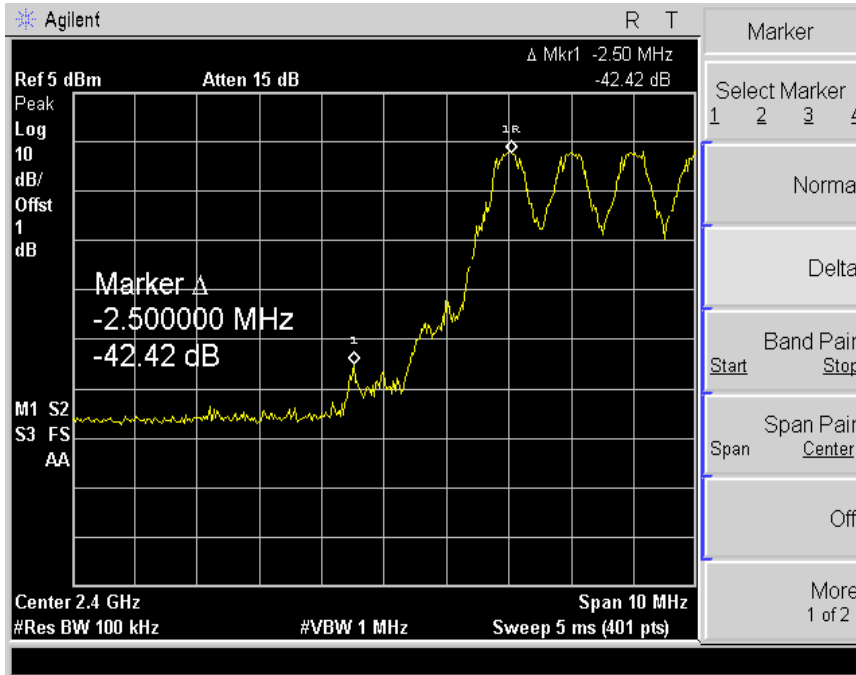

CH78

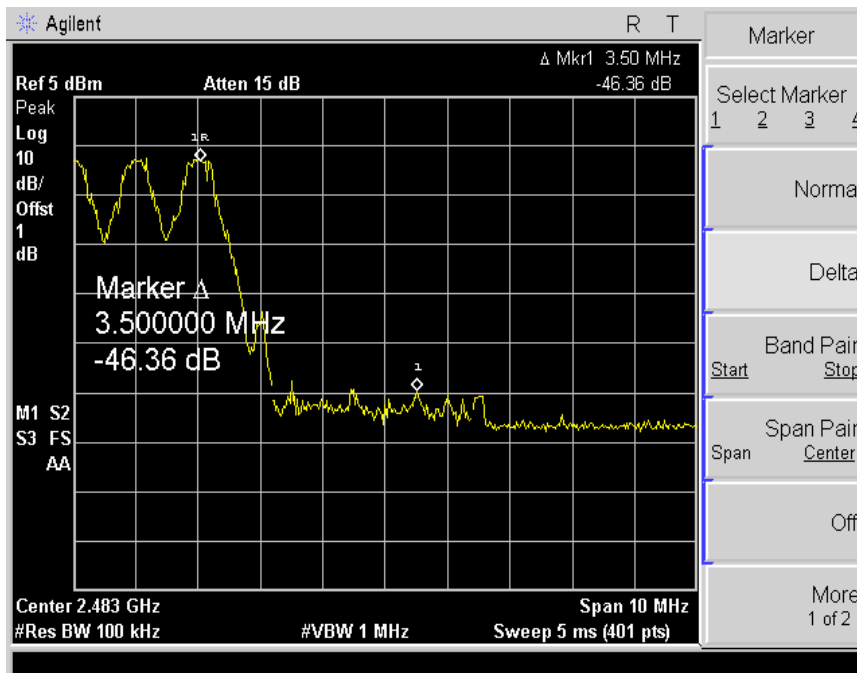



ESTECH Co., Ltd.

Rm 1015, World Venture Center 11,
426-5 Gasan-dong, Guncheon-gu,
Seoul, 158-803, Korea



**Electromagnetic
Interference
Test Report**

8DPSK

CH 0

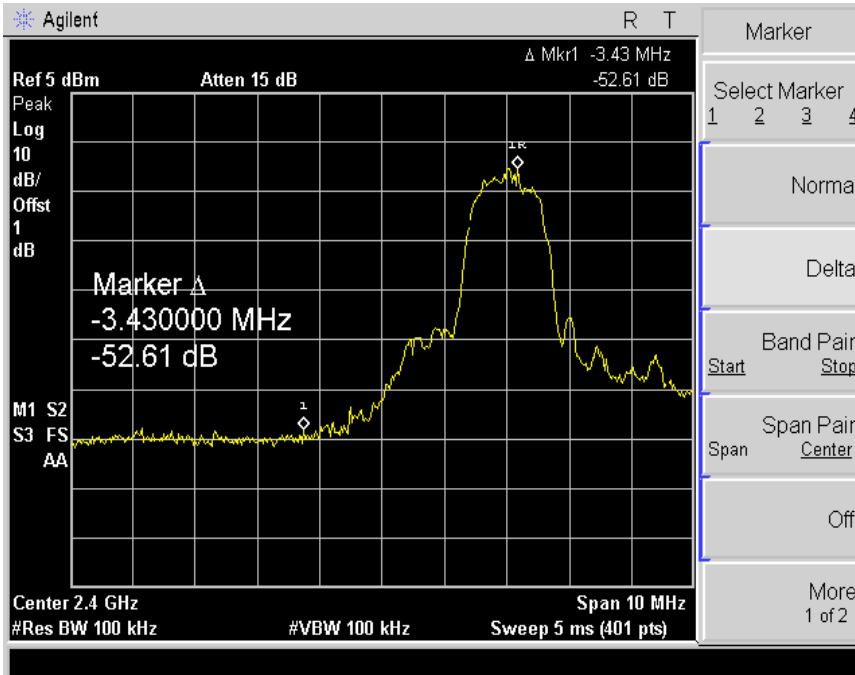

CH78

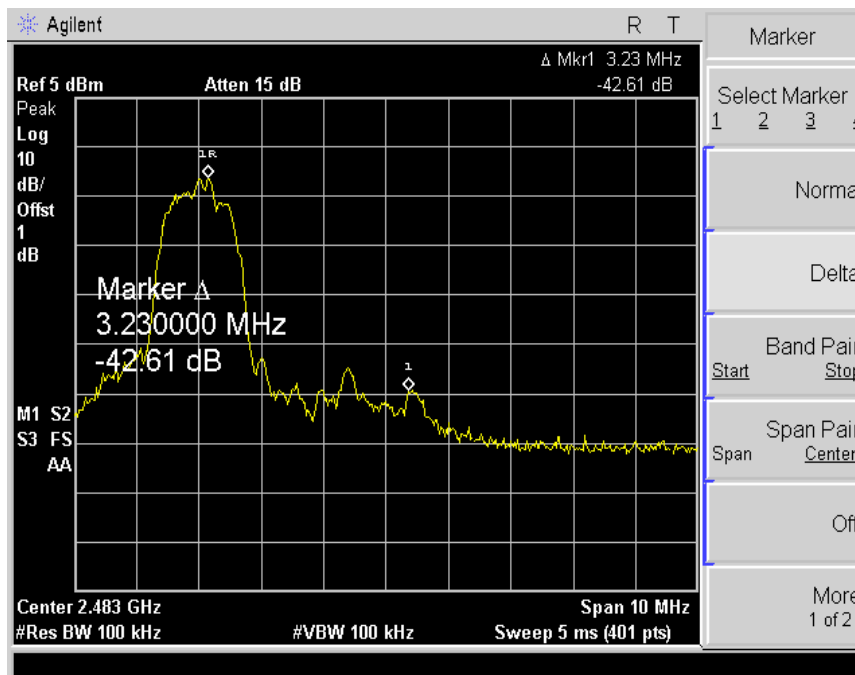



ESTECH Co., Ltd.

Rm 1015, World Venture Center 11,
426-5 Gasan-dong, Guncheon-gu,
Seoul, 158-803, Korea



**Electromagnetic
Interference
Test Report**

Hopping on CH 0

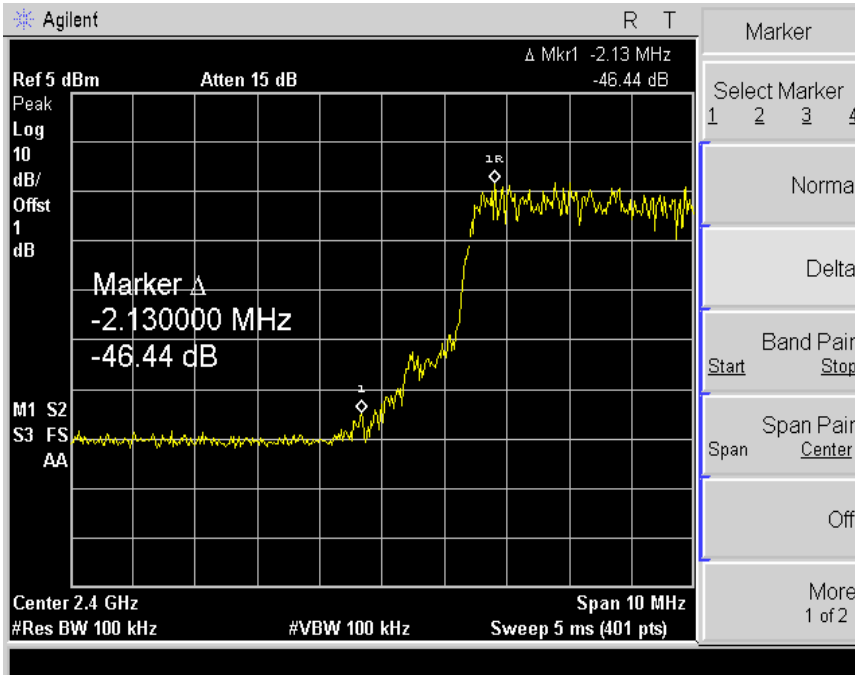

CH78

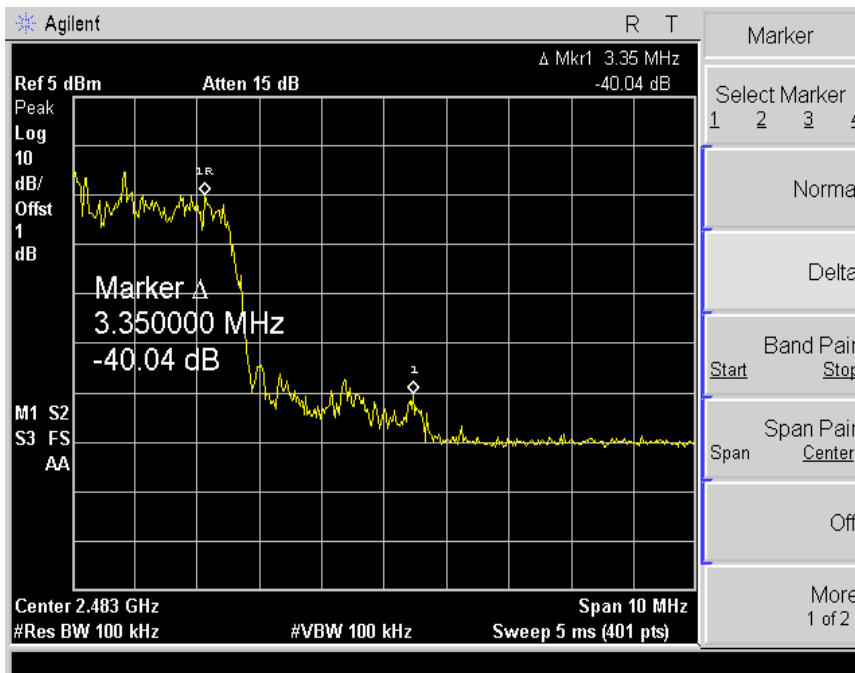



ESTECH Co., Ltd.

Rm 1015, World Venture Center 11,
426-5 Gasan-dong, Guncheon-gu,
Seoul, 158-803, Korea



**Electromagnetic
Interference
Test Report**

**GFSK
CH 0**

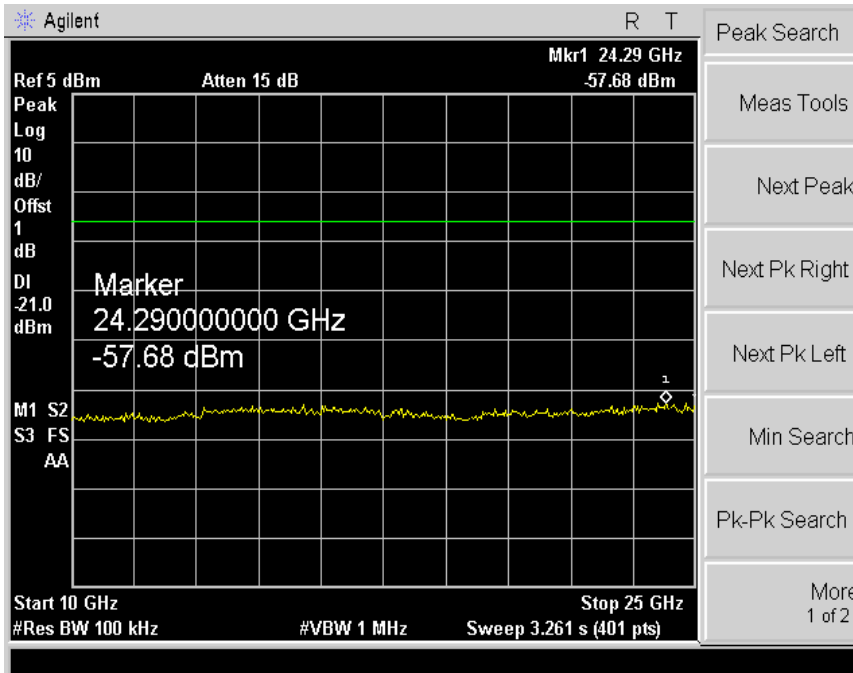
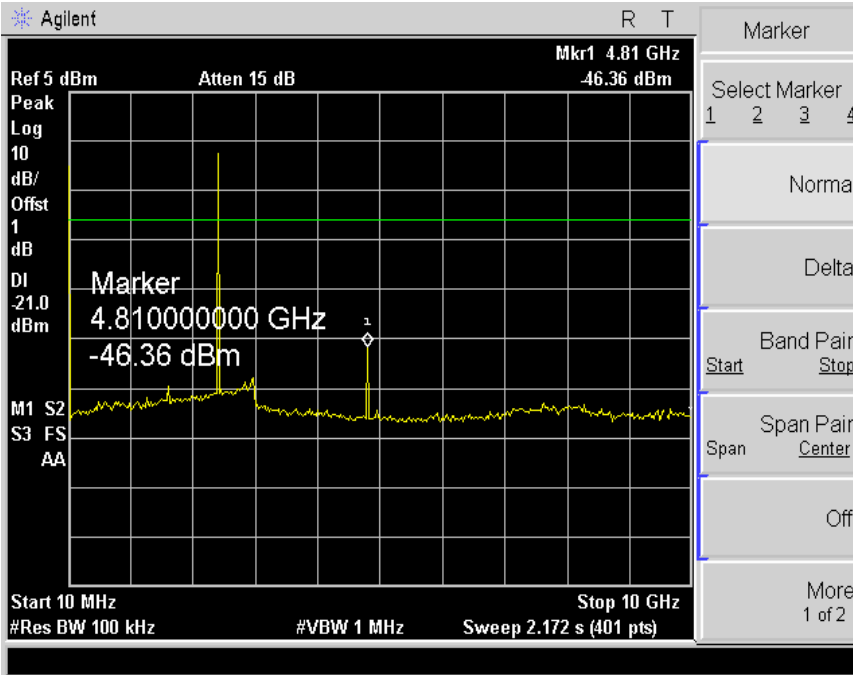



ESTECH Co., Ltd.

Rm 1015, World Venture Center 11,
426-5 Gasan-dong, Guncheon-gu,
Seoul, 158-803, Korea



**Electromagnetic
Interference
Test Report**

CH 39

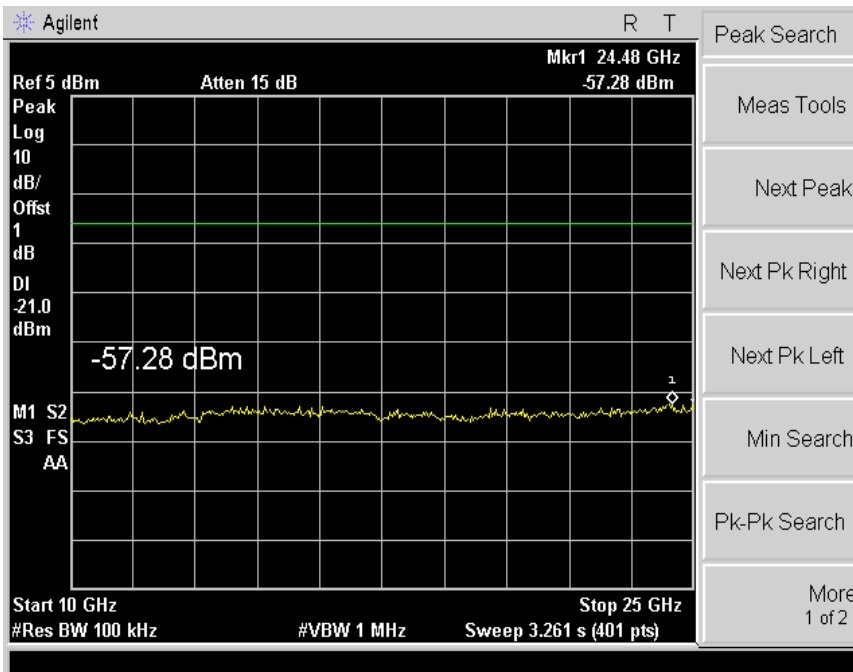
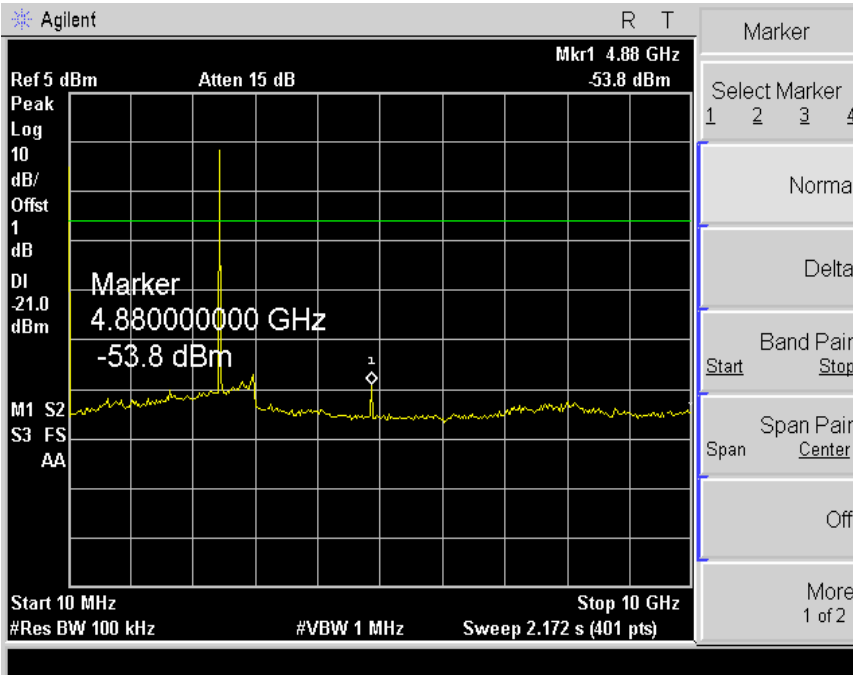



ESTECH Co., Ltd.

Rm 1015, World Venture Center 11,
426-5 Gasan-dong, Guncheon-gu,
Seoul, 158-803, Korea



**Electromagnetic
Interference
Test Report**

CH 78

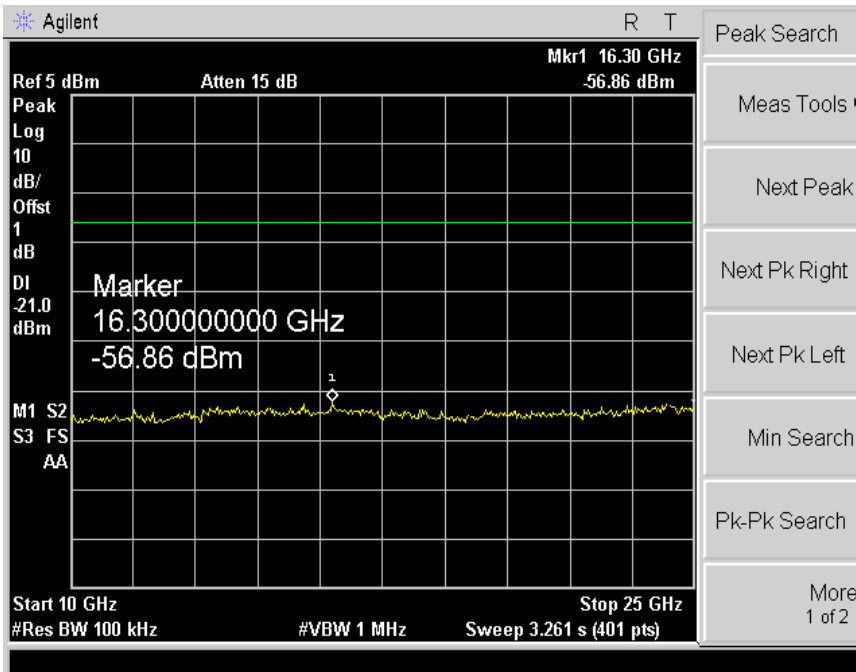
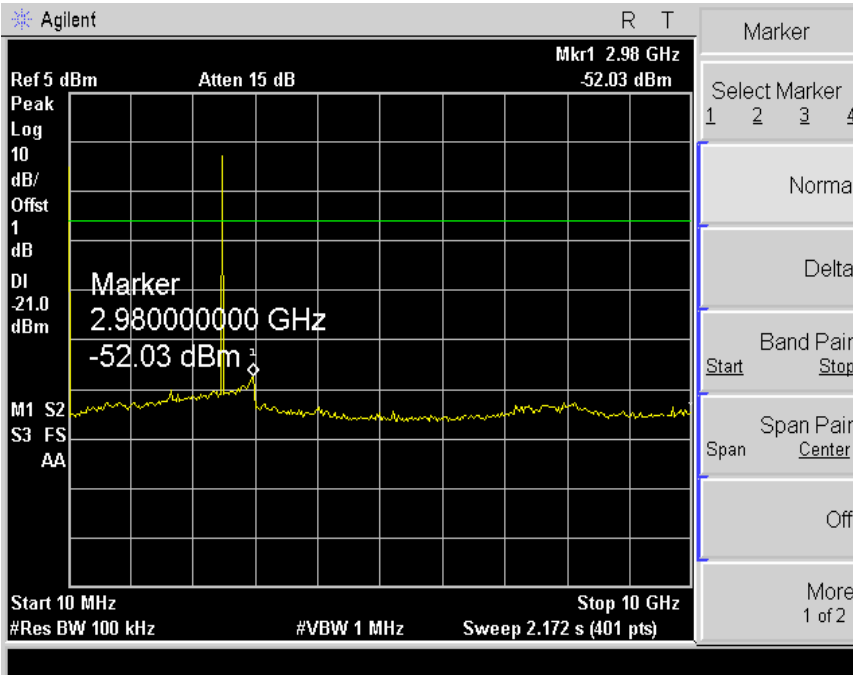



ESTECH Co., Ltd.

Rm 1015, World Venture Center 11,
426-5 Gasan-dong, Guncheon-gu,
Seoul, 158-803, Korea



**Electromagnetic
Interference
Test Report**

8DPSK

CH 0

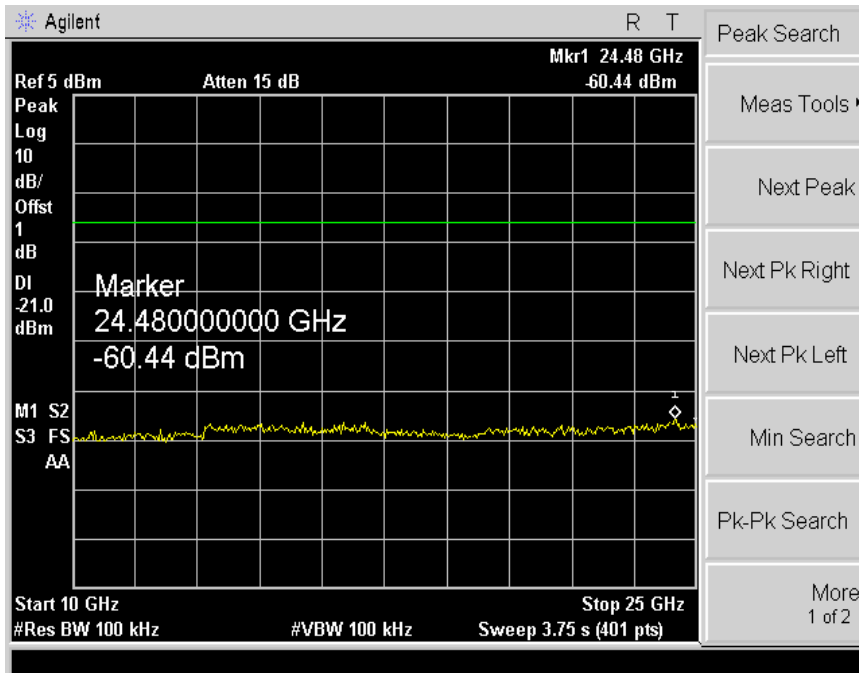
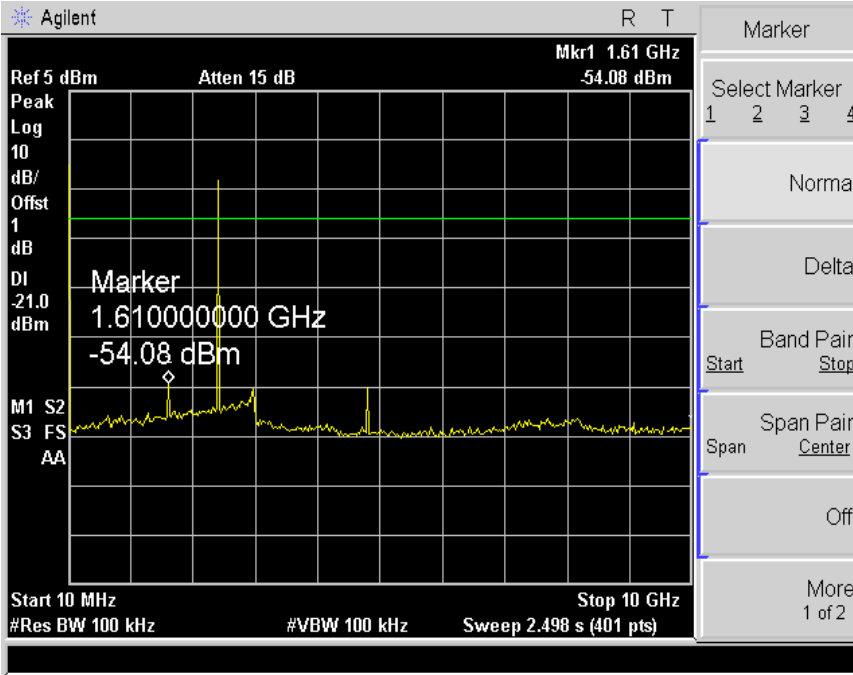



ESTECH Co., Ltd.

Rm 1015, World Venture Center 11,
426-5 Gasan-dong, Guncheon-gu,
Seoul, 158-803, Korea



**Electromagnetic
Interference
Test Report**

CH 39

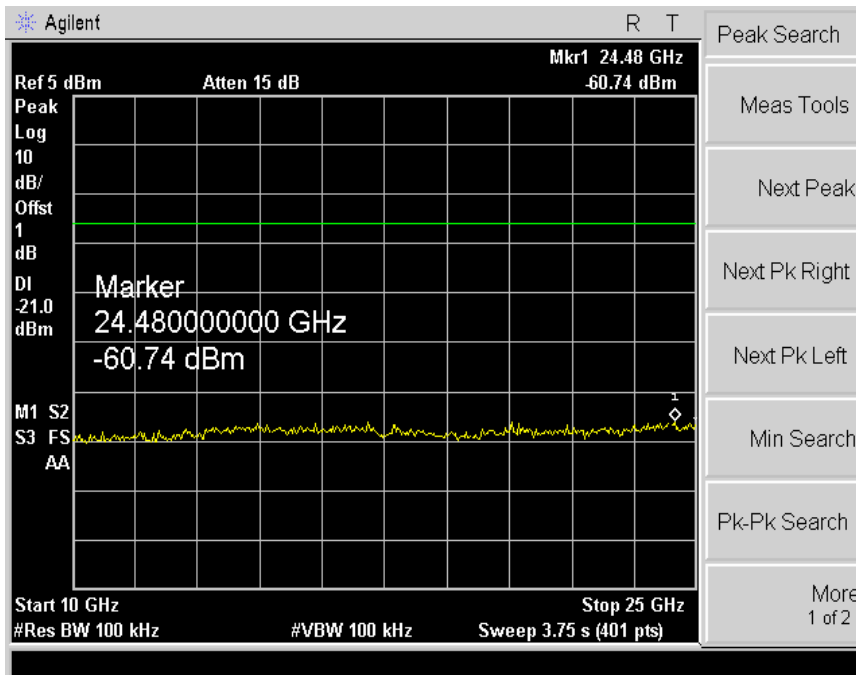
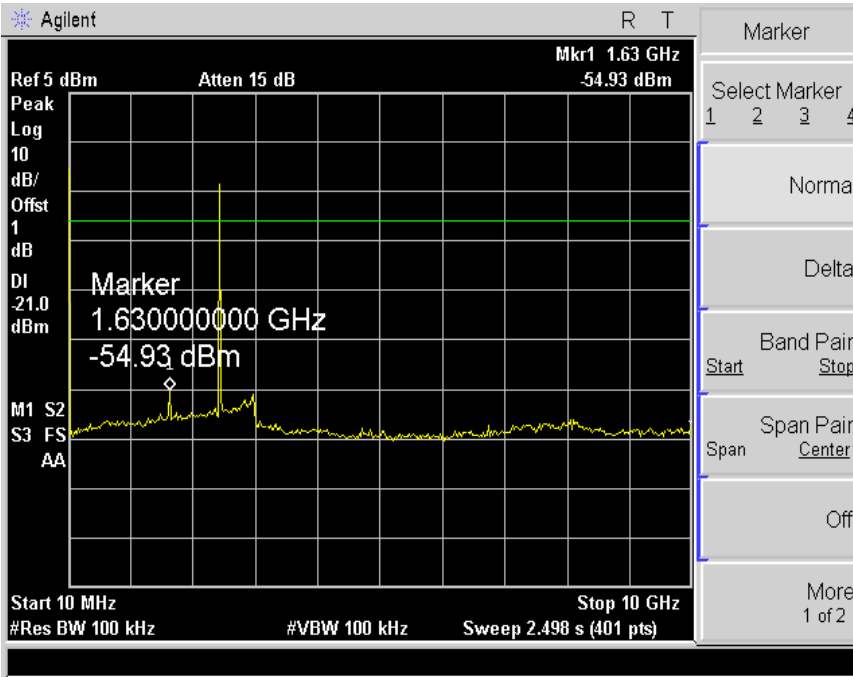



ESTECH Co., Ltd.

Rm 1015, World Venture Center 11,
426-5 Gasan-dong, Guncheon-gu,
Seoul, 158-803, Korea



**Electromagnetic
Interference
Test Report**

CH 78

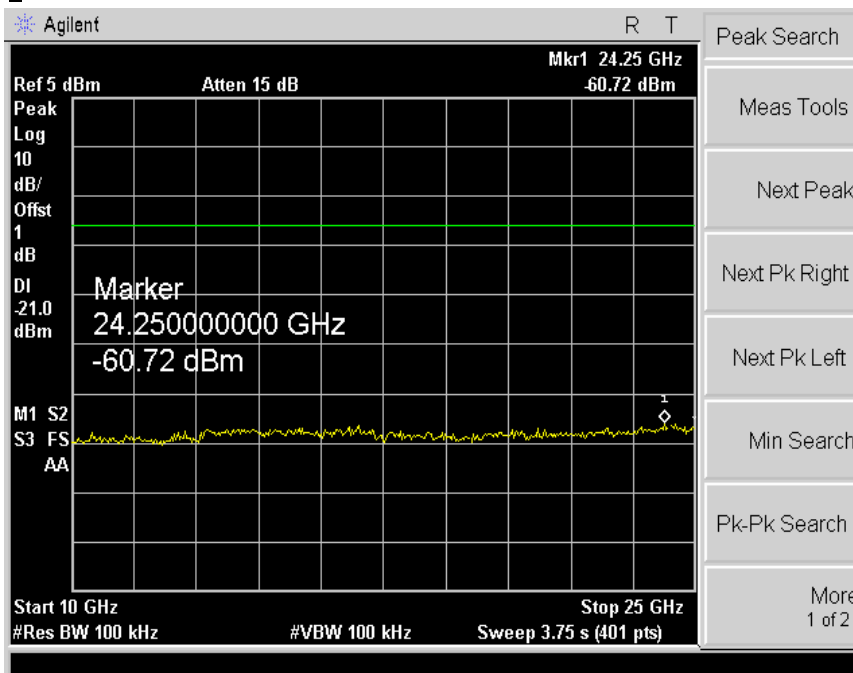
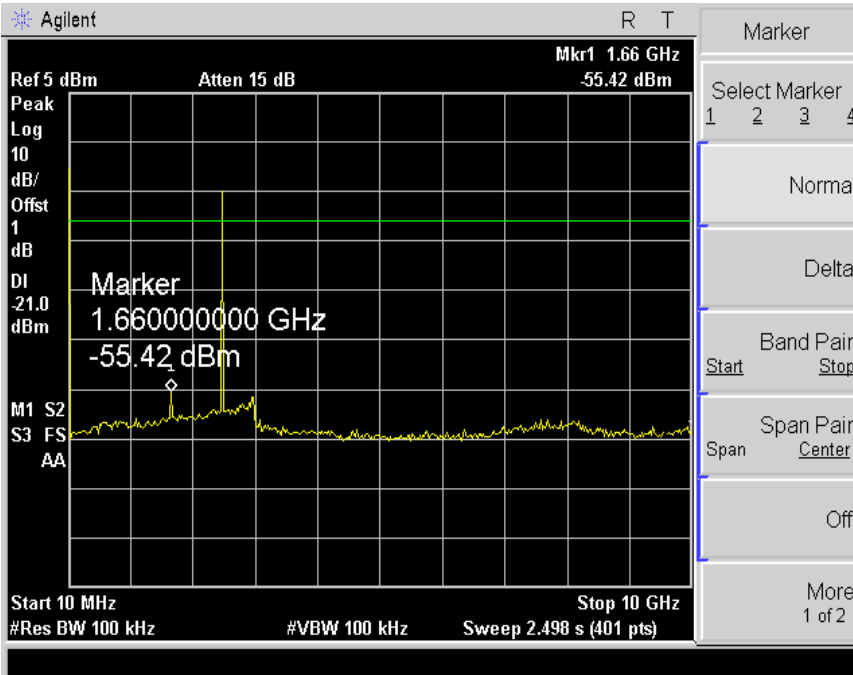

10. Measurement of radiated disturbance

Above 30 MHz Electric Field strength was measured in accordance with FCC Part 15 (2007) & ANSI C 63.4 (2003). The test setup was made according to FCC Part 15 (2007) & ANSI C 63.4 (2003) on an open test site, which allows a 3m distance measurement. The EUT was placed in the center of wooden turntable. The height of this table was 0.8m. The measurement was conducted with both horizontal and vertical antenna polarization. The turntable has fully rotated. For further description of the configuration refer to the picture of the test setup.

10.1 Measurement equipments

Equipment Name	Type	Manufacturer	Serial No.	Next Calibration date
TEST Receiver	ESVS10	Rohde & Schwarz	838562/002	2010. 1. 29
Spectrum Analyzer	R3273	ADVANTEST	110600592	2009. 6. 09
LogBicon Antenna	VULB 9160	Schwarzbeck	3142	2009. 5. 15
Turn Table	2087	EMCO	2129	-
Antenna Mast	2070-01	EMCO	9702-203	-
ANT Mast Controller	2090	EMCO	1535	-
Horn Antenna	BBHA 9120 D	Schwarzbeck	469	2009. 6. 13
Amplifier	8447F	HP	2805A02972	2009. 6. 26
Turn Table Controller	2090	EMCO	1535	-
PREAMPLIFIER	8449B	Sonoma Instrument	3008A00595	2009. 12. 24

10.2 Environmental Condition

Test Place : Open site(3m)
 Temperature (°C) : 9
 Humidity (%) : 36 %

10.3-1 Test data

Test Date : 25-Mar-09

Measurement Distance : 3 m

Frequency (MHz)	Reading (dB μ V)	Position (V/H)	Height (m)	Correction Factor		Result Value		
				Ant Factor (dB)	Cable (dB)	Limit (dB μ V/m)	Result (dB μ V/m)	Margin (dB)
34.50	15.00	V	1.0	11.27	0.9	40.0	27.14	-12.86
67.54	16.10	V	1.0	10.71	1.2	40.0	28.05	-11.95
158.34	17.30	V	1.0	12.77	2.0	43.5	32.04	-11.46
166.32	21.30	H	1.6	12.74	2.0	43.5	36.07	-7.43
200.01	23.70	V	1.0	9.67	2.3	43.5	35.69	-7.81
235.64	21.40	H	1.5	10.72	2.6	46.0	34.71	-11.29
300.21	18.10	H	1.5	12.95	3.2	46.0	34.23	-11.77
312.01	20.00	H	1.5	12.97	3.2	46.0	36.14	-9.86
365.93	21.70	V	1.0	14.24	3.7	46.0	39.62	-6.38
500.01	10.30	V	1.0	17.10	4.7	46.0	32.15	-13.85
796.43	6.00	V	1.0	22.00	6.8	46.0	34.85	-11.15
Remark	H : Horizontal, V : Vertical *Checked in all 3 axis(X,Y,Z) and Y axis were reported by the maximum measured data. *CL = Cable Loss - Amplifier Gain(In case of above1000Mhz) *CL = Cable Loss(In case of below1000Mhz) *The resolution bandwidth and video bandwidth of test receiver/spectrum analyzer is 120KHz for Quasi-peak detection at frequency below 1GHz.							

10.3-2 Test data(CH0)(GFSK)

Test Date : 25-Mar-09

Measurement Distance : 3 m

Frequency (MHz)	Reading (dBμV)	Position (V/H)	Height (m)	Correction Factor		Result Value		
				Ant Factor (dB)	Cable (dB)	Limit (dBμV/m)	Result (dBμV/m)	Margin (dB)
PEAK(RBW / VBW-1MHz)								
1620.00	51.32	H	1.5	24.86	-28.9	74.0	47.28	-26.72
2392.00	25.18	H	1.4	26.67	4.5	74.0	56.35	-17.65
2402.00	33.48	H	1.4	26.67	4.5	*OB	64.65	-
4804.00	46.84	H	1.6	29.95	-27.9	74.0	48.89	-25.11
1620.00	53.34	V	1.5	24.86	-28.9	74.0	49.30	-24.70
2392.00	24.66	V	1.3	26.67	4.5	74.0	55.83	-18.17
2402.00	37.18	V	1.3	26.67	4.5	*OB	68.35	-
4804.00	48.48	V	1.5	29.95	-27.9	74.0	50.53	-23.47
AV(RBW 1MHz / VBW 10Hz)								
1620.00	47.23	H	1.5	24.86	-28.9	54.0	43.19	-10.81
2392.00	12.06	H	1.4	26.67	4.5	54.0	43.23	-10.77
2402.00	29.94	H	1.4	26.67	4.5	*OB	61.11	-
4804.00	33.34	H	1.6	29.95	-27.9	54.0	35.39	-18.61
1620.00	48.01	V	1.5	24.86	-28.9	54.0	43.97	-10.03
2392.00	12.16	V	1.3	26.67	4.5	54.0	43.33	-10.67
2402.00	34.85	V	1.3	26.67	4.5	*OB	66.02	-
4804.00	34.38	V	1.5	29.95	-27.9	54.0	36.43	-17.57
Remark	H : Horizontal, V : Vertical TEST MODE : CH 0(2402MHz) *The TX signal isn't detected from 2th harmonics. *OB = Operating band *Checked in all 3 axis(X,Y,Z) and Y axis were reported by the maximum measured data. *CL = Cable Loss-Amplifier Gain(In case of above1000Mhz) *CL = Cable Loss(In case of below1000Mhz)							

10.3-3 Test data(CH39)(GFSK)

Test Date : 25-Mar-09

Measurement Distance : 3 m

Frequency (MHz)	Reading (dBμV)	Position (V/H)	Height (m)	Correction Factor		Result Value		
				Ant Factor (dB)	Cable (dB)	Limit (dBμV/m)	Result (dBμV/m)	Margin (dB)
PEAK(RBW / VBW - 1MHz)								
1635.00	51.41	H	1.5	24.86	-28.9	74.0	47.37	-27.51
2441.00	34.40	H	1.6	26.67	4.5	*OB	65.57	-
4882.00	43.39	H	1.5	29.95	-27.9	74.0	45.44	-28.56
1635.00	51.27	V	1.5	24.86	-28.9	74.0	47.23	-29.67
2441.00	37.12	V	1.4	26.67	4.5	*OB	68.29	-
4882.00	43.54	V	1.4	29.95	-27.9	74.0	45.59	-28.41
AV(RBW 1MHz / VBW 10Hz)								
1635.00	46.37	H	1.5	24.86	-28.9	54.0	42.33	-11.17
2441.00	31.25	H	1.6	26.67	4.5	*OB	62.42	-
4882.00	31.30	H	1.5	29.95	-27.9	54.0	33.35	-20.65
1635.00	46.94	V	1.5	24.86	-28.9	54.0	42.90	-11.10
2441.00	36.46	V	1.4	26.67	4.5	*OB	67.63	-
4882.00	31.33	V	1.4	29.95	-27.9	54.0	33.38	-20.62
Remark	H : Horizontal, V : Vertical TEST MODE : CH 39 (2441MHz) *The TX signal isn't detected from 2th harmonics. *OB = Operating band *Checked in all 3 axis(X,Y,Z) and Y axis were reported by the maximum measured data. *CL = Cable Loss-Amplifier Gain(In case of above1000Mhz) *CL = Cable Loss(In case of below1000Mhz)							

10.3-4 Test data(CH78)(GFSK)

Test Date : 25-Mar-09

Measurement Distance : 3 m

Frequency (MHz)	Reading (dBμV)	Position (V/H)	Height (m)	Correction Factor		Result Value		
				Ant Factor (dB)	Cable (dB)	Limit (dBμV/m)	Result (dBμV/m)	Margin (dB)
PEAK(RBW / VBW - 1MHz)								
1650.00	51.47	H	1.5	24.86	-28.9	74.0	47.43	-28.88
2480.00	32.48	H	1.4	26.67	4.5	*OB	63.65	-
2483.00	24.87	H	1.4	26.67	4.5	74.0	56.04	-17.96
4960.00	41.46	H	1.5	29.95	-27.9	74.0	43.51	-30.49
1650.00	53.74	V	1.5	24.86	-28.9	74.0	49.70	-28.05
2480.00	35.90	V	1.4	26.67	4.5	*OB	67.07	-
2483.00	24.07	V	1.4	26.67	4.5	74.0	55.24	-18.76
4960.00	46.26	V	1.4	29.95	-27.9	74.0	48.31	-25.69
AV(RBW 1MHz / VBW 10Hz)								
1650.00	47.01	H	1.5	24.86	-28.9	54.0	42.97	-13.88
2480.00	29.08	H	1.4	26.67	4.5	*OB	60.25	-
2483.00	11.80	H	1.4	26.67	4.5	54.0	42.97	-11.03
4960.00	29.59	H	1.5	29.95	-27.9	54.0	31.64	-22.36
1650.00	48.12	V	1.5	24.86	-28.9	54.0	44.08	-11.88
2480.00	33.09	V	1.4	26.67	4.5	*OB	64.26	-
2483.00	11.80	V	1.4	26.67	4.5	54.0	42.97	-11.03
4960.00	30.77	V	1.4	29.95	-27.9	54.0	32.82	-21.18
Remark	H : Horizontal, V : Vertical TEST MODE : CH 78 (2480MHz) *The TX signal isn't detected from 2th harmonics. *OB = Operating band *Checked in all 3 axis(X,Y,Z) and Y axis were reported by the maximum measured data. *CL = Cable Loss-Amplifier Gain(In case of above1000Mhz) *CL = Cable Loss(In case of below1000Mhz)							

10.3-5 Test data(CH0)(8DPSK)

Test Date : 25-Mar-09

Measurement Distance : 3 m

Frequency (MHz)	Reading (dB μ V)	Position (V/H)	Height (m)	Correction Factor		Result Value		
				Ant Factor (dB)	Cable (dB)	Limit (dB μ V/m)	Result (dB μ V/m)	Margin (dB)
PEAK(RBW / VBW-1MHz)								
1620.00	51.32	H	1.4	24.86	-28.9	74.0	47.28	-26.72
2392.00	24.25	H	1.7	26.67	4.5	74.0	55.42	-18.58
2402.00	33.58	H	1.7	26.67	4.5	*OB	64.75	-
4804.00	46.48	H	1.4	29.95	-27.9	74.0	48.53	-25.47
1620.00	52.34	V	1.5	24.86	-28.9	74.0	48.30	-25.70
2392.00	24.38	V	1.5	26.67	4.5	74.0	55.55	-18.45
2402.00	38.09	V	1.5	26.67	4.5	*OB	69.26	-
4804.00	49.40	V	1.4	29.95	-27.9	74.0	51.45	-22.55
AV(RBW 1MHz / VBW 10Hz)								
1620.00	47.20	H	1.4	24.86	-28.9	54.0	43.16	-10.84
2392.00	11.92	H	1.7	26.67	4.5	54.0	43.09	-10.91
2402.00	28.65	H	1.7	26.67	4.5	*OB	59.82	-
4804.00	33.50	H	1.4	29.95	-27.9	54.0	35.55	-18.45
1620.00	47.60	V	1.5	24.86	-28.9	54.0	43.56	-10.44
2392.00	12.00	V	1.5	26.67	4.5	54.0	43.17	-10.83
2402.00	33.03	V	1.5	26.67	4.5	*OB	64.20	-
4804.00	34.81	V	1.4	29.95	-27.9	54.0	36.86	-17.14
Remark	H : Horizontal, V : Vertical TEST MODE : CH 0(2402MHz) *The TX signal isn't detected from 2th harmonics. *OB = Operating band *Checked in all 3 axis(X,Y,Z) and Y axis were reported by the maximum measured data. *CL = Cable Loss-Amplifier Gain(In ca							

10.3-6 Test data(CH39)(8DPSK)

Test Date : 25-Mar-09

Measurement Distance : 3 m

Frequency (MHz)	Reading (dB μ V)	Position (V/H)	Height (m)	Correction Factor		Result Value		
				Ant Factor (dB)	Cable (dB)	Limit (dB μ V/m)	Result (dB μ V/m)	Margin (dB)
PEAK(RBW / VBW - 1MHz)								
1635.00	50.40	H	1.5	24.86	-28.9	74.0	46.36	-27.51
2441.00	33.05	H	1.4	26.67	4.5	*OB	64.22	-
4882.00	43.36	H	1.4	29.95	-27.9	74.0	45.41	-28.59
1635.00	51.23	V	1.5	24.86	-28.9	74.0	47.19	-29.67
2441.00	36.78	V	1.4	26.67	4.5	*OB	67.95	-
4882.00	44.12	V	1.4	29.95	-27.9	74.0	46.17	-27.83
AV(RBW 1MHz / VBW 10Hz)								
1635.00	46.10	H	1.5	24.86	-28.9	54.0	42.06	-11.17
2441.00	30.79	H	1.4	26.67	4.5	*OB	61.96	-
4882.00	36.09	H	1.4	29.95	-27.9	54.0	38.14	-15.86
1635.00	47.01	V	1.5	24.86	-28.9	54.0	42.97	-11.03
2441.00	35.57	V	1.4	26.67	4.5	*OB	66.74	-
4882.00	37.83	V	1.4	29.95	-27.9	54.0	39.88	-14.12
Remark	H : Horizontal, V : Vertical TEST MODE : CH 39 (2441MHz) *The TX signal isn't detected from 2th harmonics. *OB = Operating band *Checked in all 3 axis(X,Y,Z) and Y axis were reported by the maximum measured data. *CL = Cable Loss - Amplifier Gain(ln)							

10.3-7 Test data(CH78)(8DPSK)

Test Date : 25-Mar-09

Measurement Distance : 3 m

Frequency (MHz)	Reading (dBμV)	Position (V/H)	Height (m)	Correction Factor		Result Value		
				Ant Factor (dB)	Cable (dB)	Limit (dBμV/m)	Result (dBμV/m)	Margin (dB)
PEAK(RBW / VBW - 1MHz)								
1650.00	50.41	H	1.5	24.86	-28.9	74.0	46.37	-28.88
2480.00	31.54	H	1.3	26.67	4.5	*OB	62.71	-
2483.00	23.41	H	1.3	26.67	4.5	74.0	54.58	-19.42
4960.00	42.37	H	1.4	29.95	-27.9	74.0	44.42	-29.58
1650.00	54.00	V	1.5	24.86	-28.9	74.0	49.96	-28.05
2480.00	34.49	V	1.3	26.67	4.5	*OB	65.66	-
2483.00	23.76	V	1.3	26.67	4.5	74.0	54.93	-19.07
4960.00	45.27	V	1.5	29.95	-27.9	74.0	47.32	-26.68
AV(RBW 1MHz / VBW 10Hz)								
1650.00	46.51	H	1.5	24.86	-28.9	54.0	42.47	-13.88
2480.00	28.61	H	1.3	26.67	4.5	*OB	59.78	-
2483.00	11.30	H	1.3	26.67	4.5	54.0	42.47	-11.53
4960.00	30.38	H	1.4	29.95	-27.9	54.0	32.43	-21.57
1650.00	47.61	V	1.5	24.86	-28.9	54.0	43.57	-11.88
2480.00	30.33	V	1.3	26.67	4.5	*OB	61.50	-
2483.00	11.28	V	1.3	26.67	4.5	54.0	42.45	-11.55
4960.00	30.77	V	1.5	29.95	-27.9	54.0	32.82	-21.18
Remark	H : Horizontal, V : Vertical TEST MODE : CH 78 (2480MHz) *The TX signal isn't detected from 2th harmonics. *OB = Operating band *Checked in all 3 axis(X,Y,Z) and Y axis were reported by the maximum measured data. *CL = Cable Loss-Amplifier Gain(In)							



ESTECH Co., Ltd.

111, 1015, World Venture Center II,
426-5 Gasan-dong, Guncheon-gu,
Seoul, 158-803, Korea



**Electromagnetic
Interference
Test Report**

10.3-8 Restricted Band Edges(GFSK)

Band Edges(CH Low)

Detector mode:Peak

Polarity:Horizontal

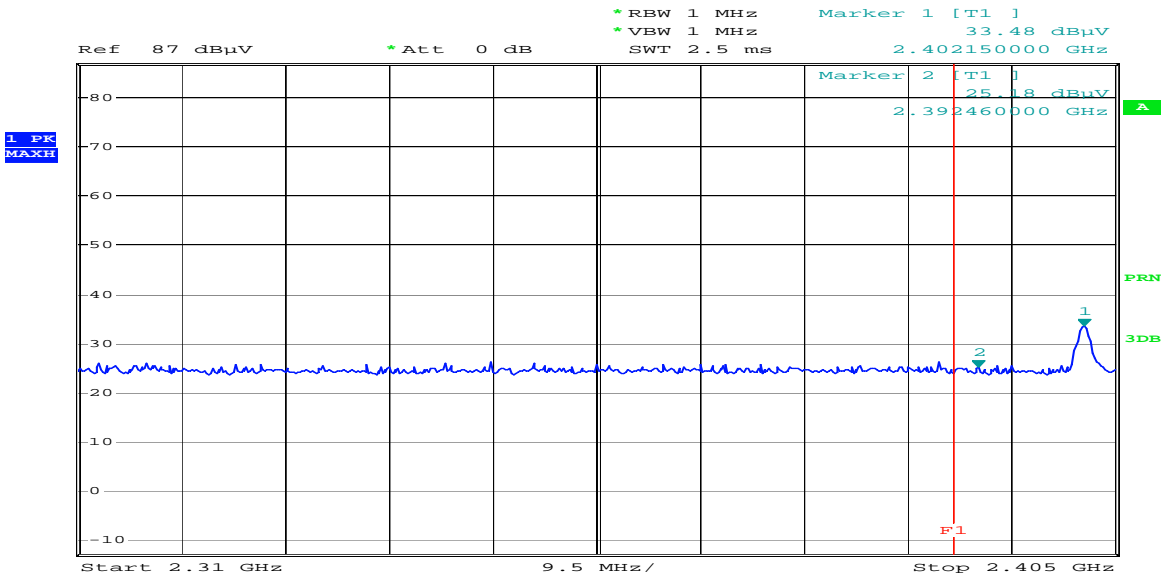

Comment: KDC300 2402 MHz_PK_HOR
Date: 25.MAR.2009 08:58:15

Detector mode:Average

Polarity:Horizontal

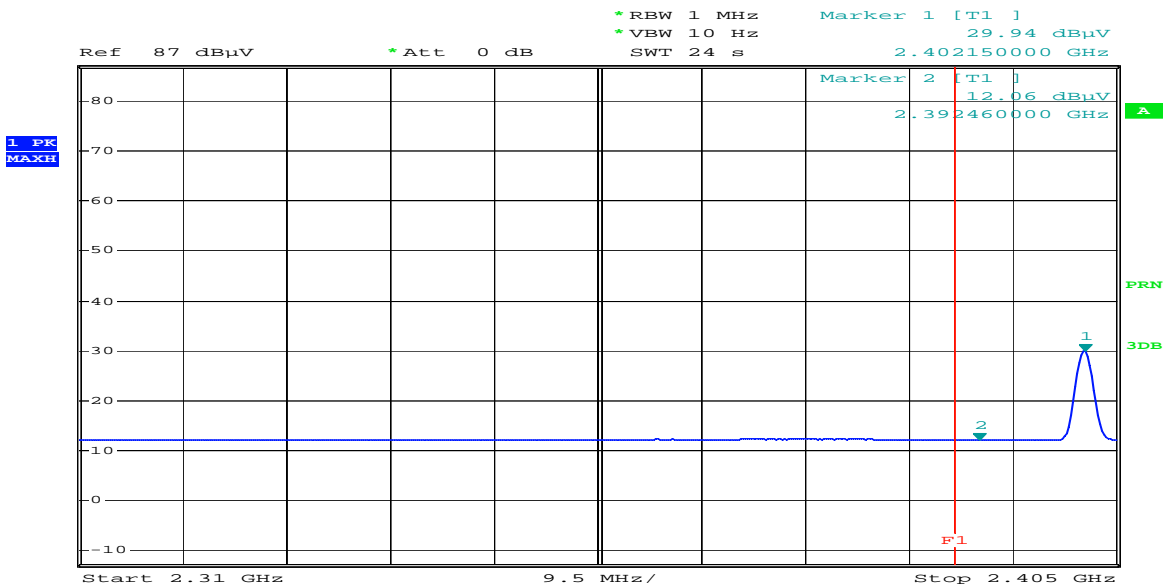

Comment: KDC300 2402 MHz_AV_HOR
Date: 25.MAR.2009 09:01:19

(GFSK)

Band Edges(CH Low)

Detector mode:Peak

Polarity:Vertical

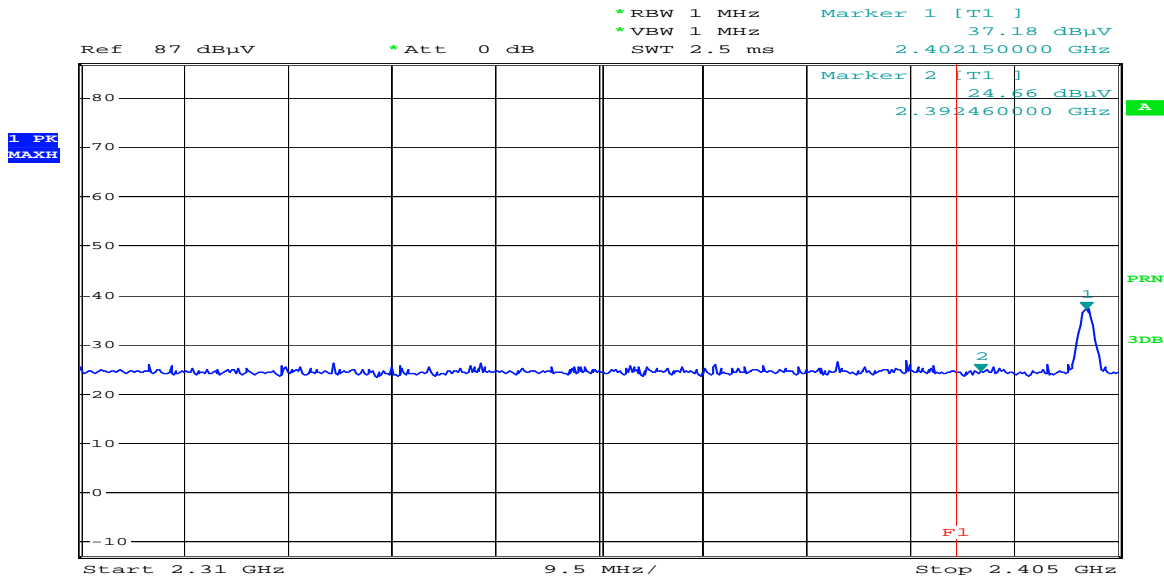

Comment: KDC300 2402 MHz_PK_VER
 Date: 25.MAR.2009 08:50:43

Detector mode:Average

Polarity:Vertical

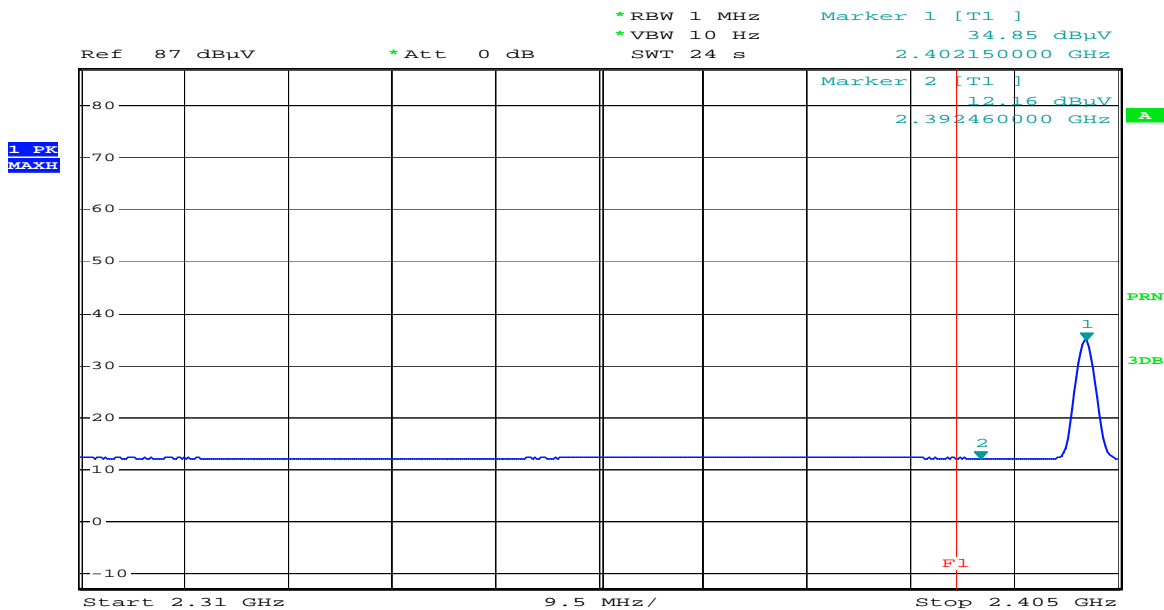

Comment: KDC300 2402 MHz_AV_VER
 Date: 25.MAR.2009 08:54:28

(GFSK)

Band Edges(CH High)

Detector mode:Peak

Polarity:Horizontal

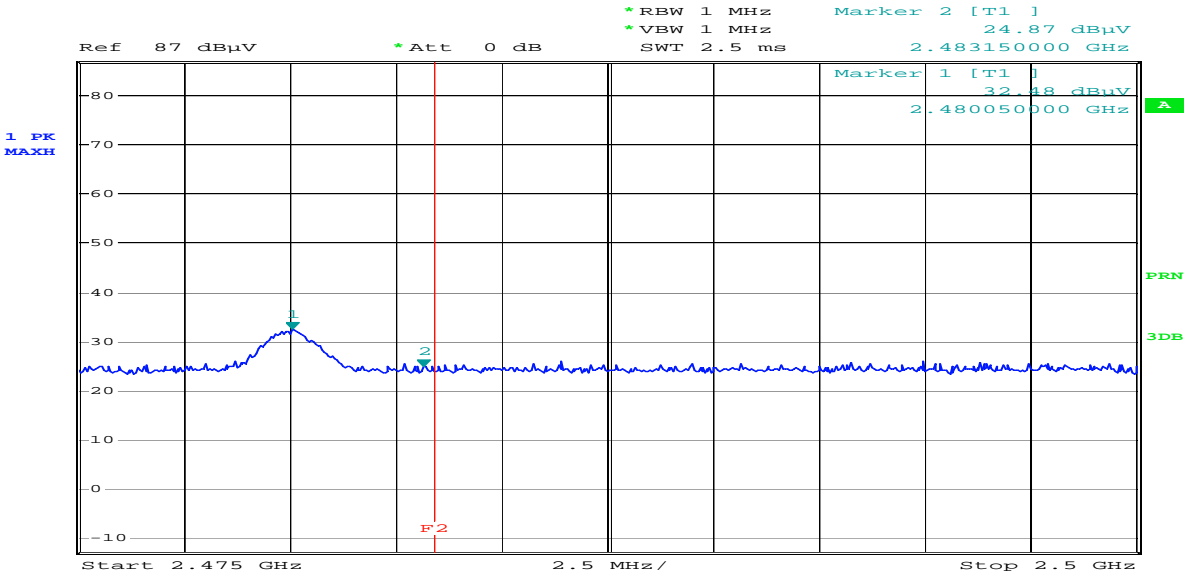

Comment: KDC300 2480 MHz_PK_HOR
 Date: 25.MAR.2009 08:38:43

Detector mode:Average

Polarity:Horizontal

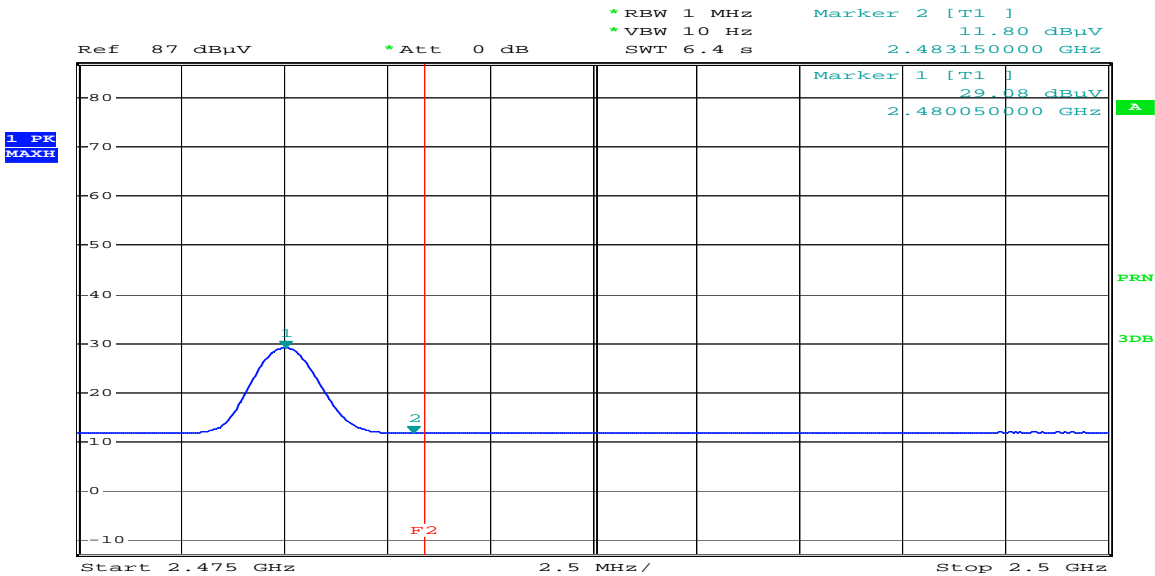

Comment: KDC300 2480 MHz_AV_HOR
 Date: 25.MAR.2009 08:41:02

(GFSK)

Band Edges(CH High)

Detector mode:Peak

Polarity:Vertical

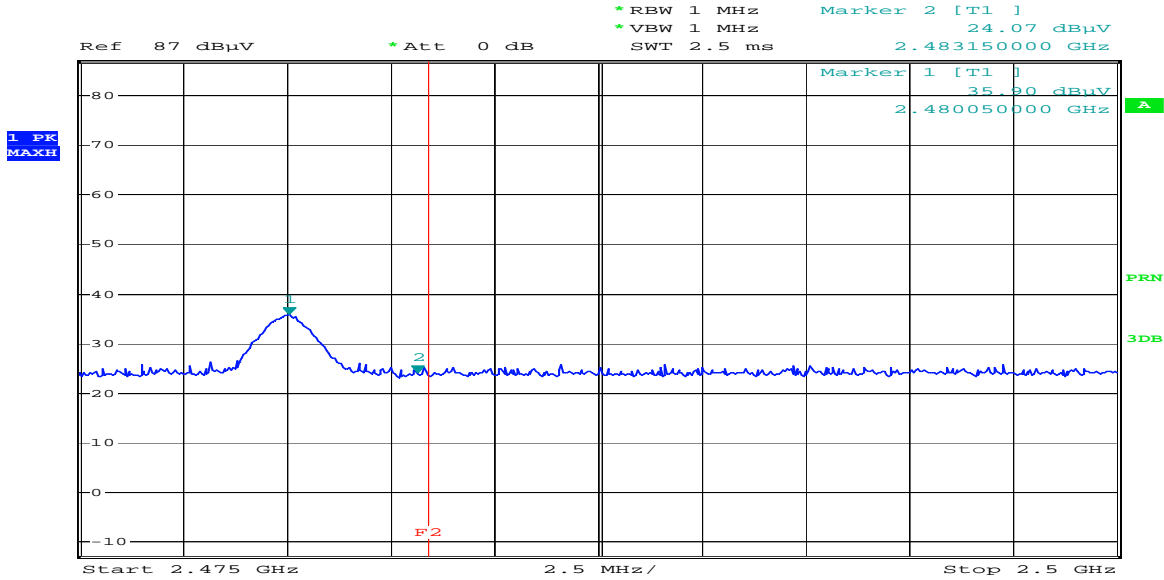

Comment: KDC300 2480 MHz_PK_VER
 Date: 25.MAR.2009 08:46:19

Detector mode:Average

Polarity:Vertical

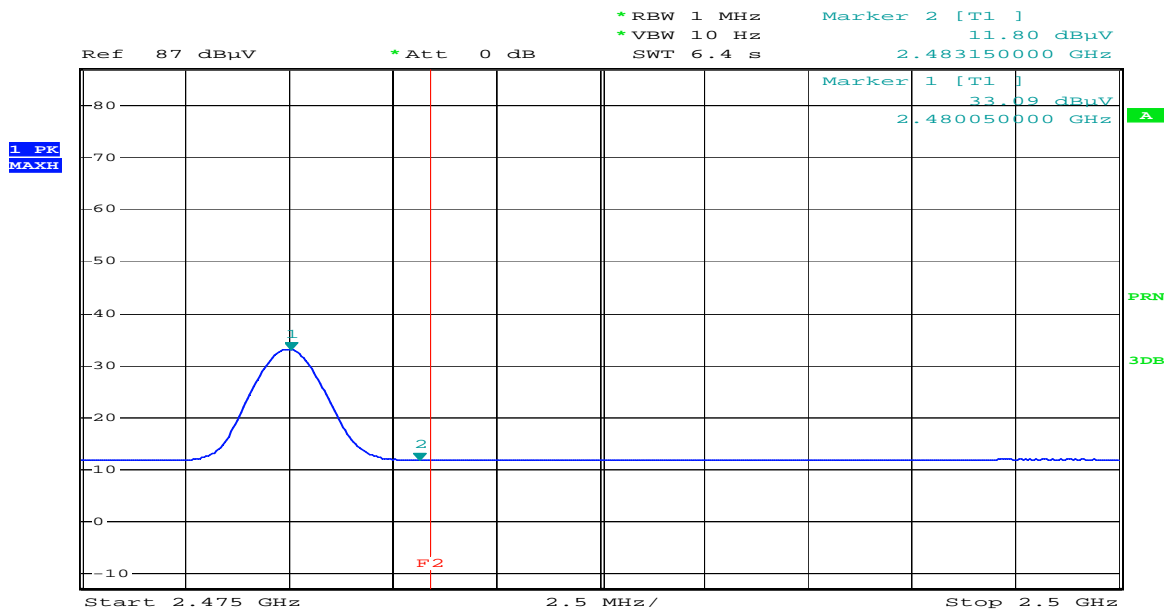

Comment: KDC300 2480 MHz_AV_VER
 Date: 25.MAR.2009 08:43:05



ESTECH Co., Ltd.

111, 1015, World Venture Center II,
426-5 Gasan-dong, Guncheon-gu,
Seoul, 158-803, Korea



**Electromagnetic
Interference
Test Report**

10.3-9 Restricted Band Edges(8DPSK)

Band Edges(CH Low)

Detector mode:Peak

Polarity:Horizontal

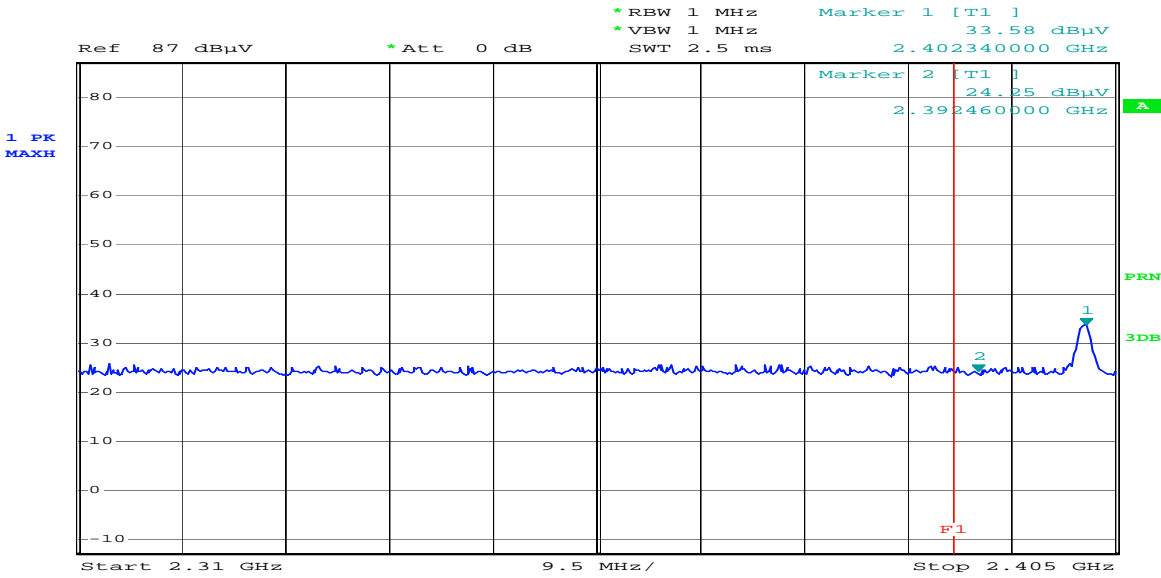

Comment: KDC300 2402 MHz_EDR_PK_HOR
Date: 25.MAR.2009 09:16:35

Detector mode:Average

Polarity:Horizontal

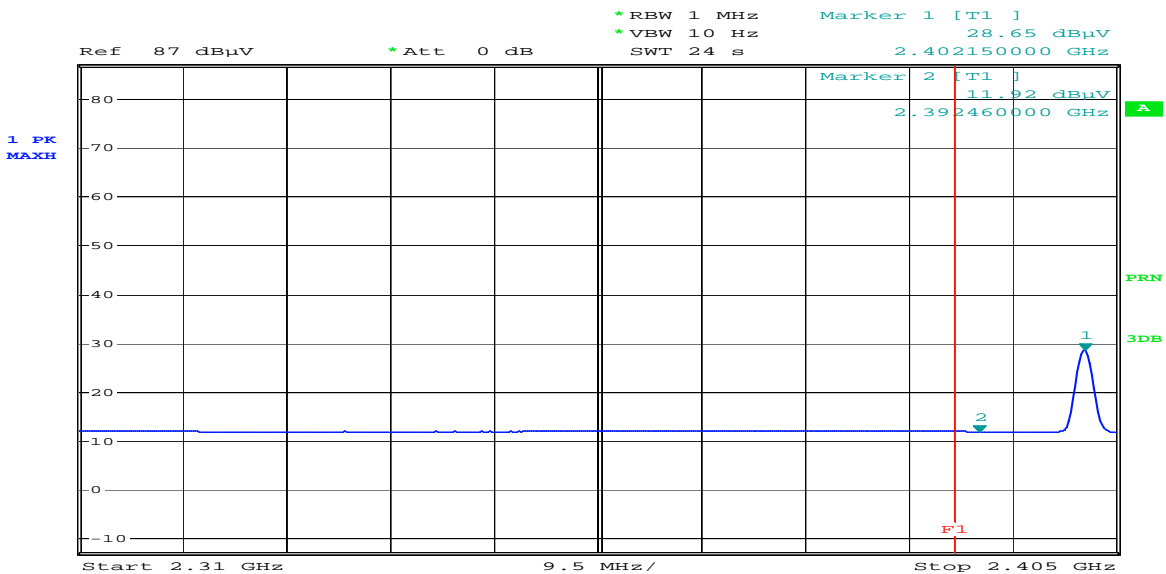

Comment: KDC300 2402 MHz_EDR_AV_HOR
Date: 25.MAR.2009 09:36:42

(8DPSK)

Band Edges(CH Low)

Detector mode:Peak

Polarity:Vertical

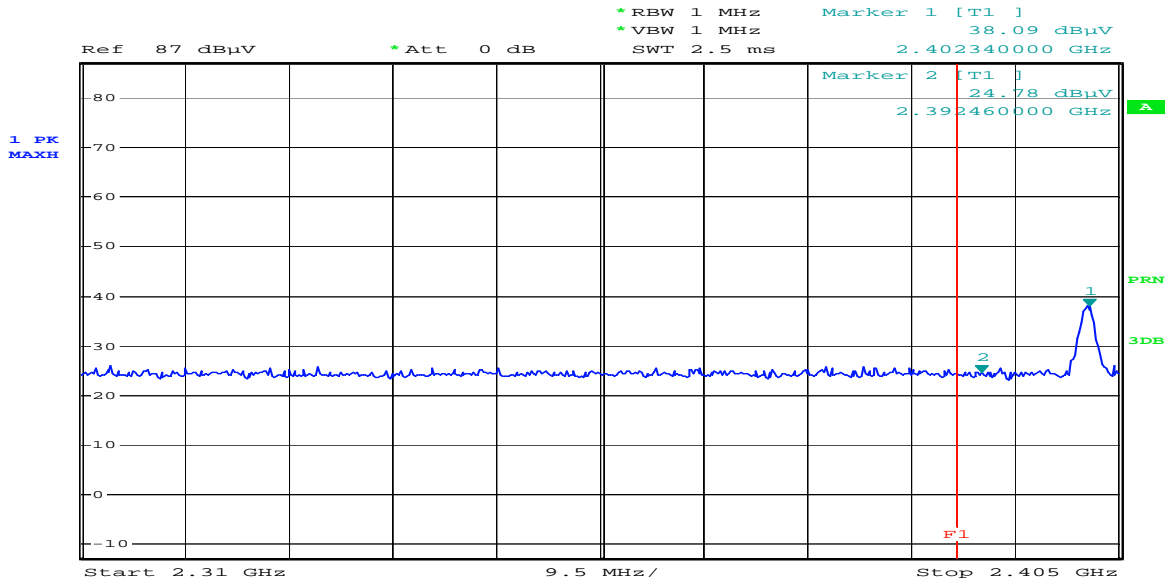

Comment: KDC300 2402 MHz_EDR_PK_VER
Date: 25.MAR.2009 09:08:23

Detector mode:Average

Polarity:Vertical

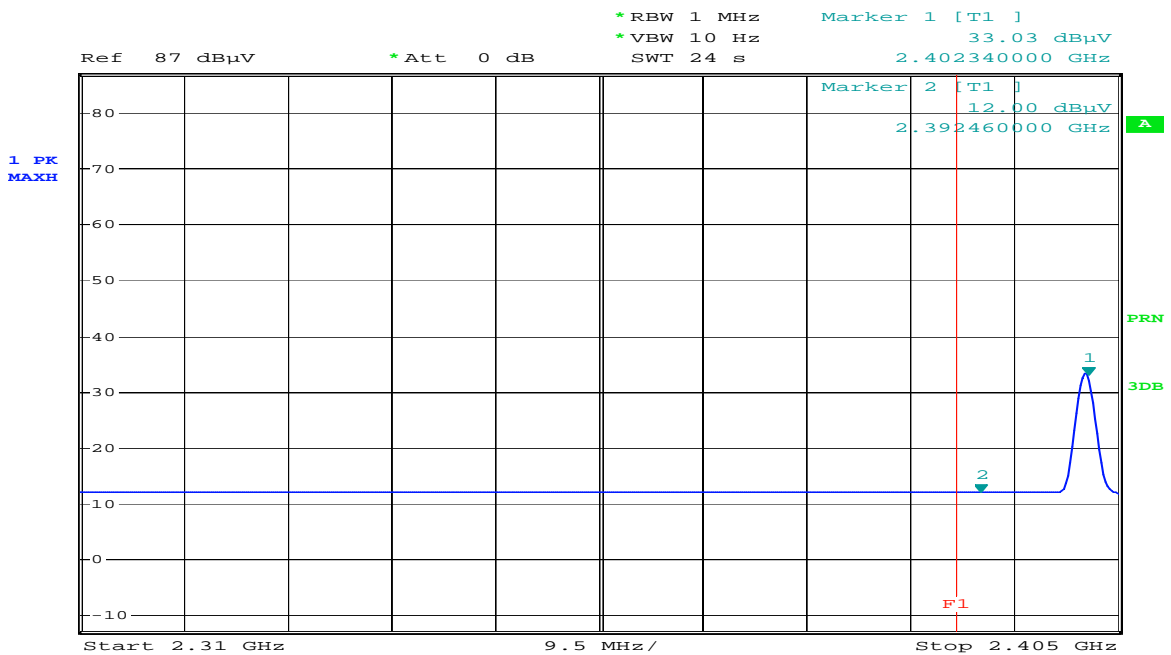

Comment: KDC300 2402 MHz_EDR_AV_VER
Date: 25.MAR.2009 09:12:15

(8DPSK)

Band Edges(CH High)

Detector mode:Peak

Polarity:Vertical

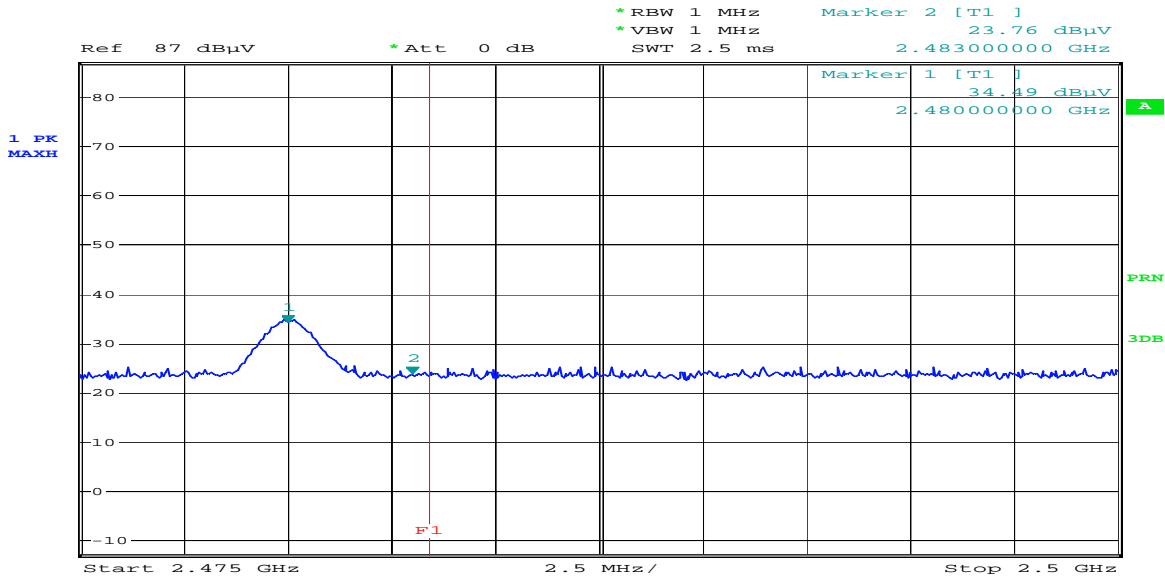

Comment: KDC300 2480 MHz_EDR_PK_VER
 Date: 25.MAR.2009 09:52:20

Detector mode:Average

Polarity:Vertical

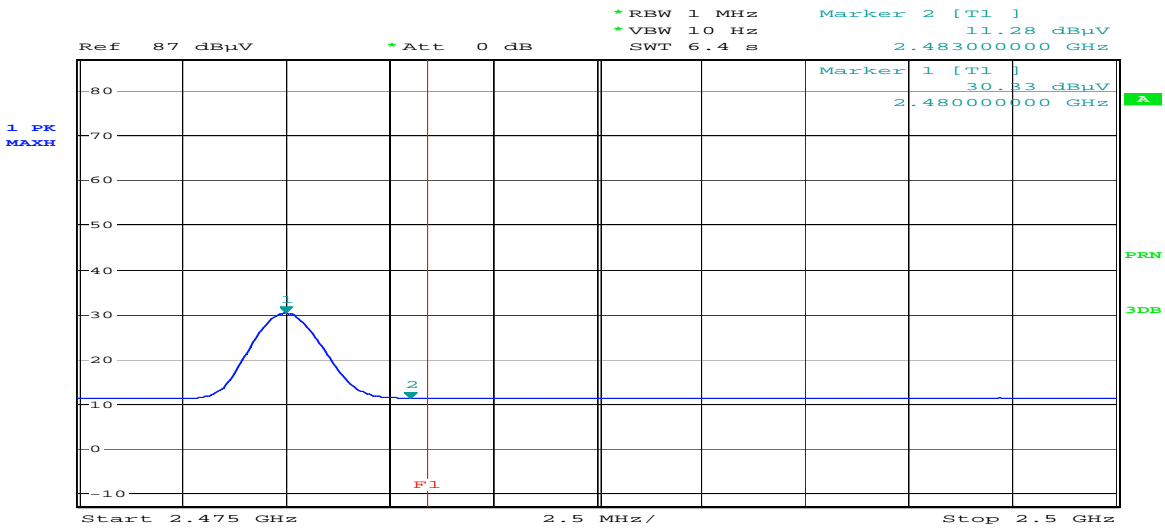

Comment: KDC300 2480 MHz_EDR_AV_VER
 Date: 25.MAR.2009 09:54:08

11. Measurement of conducted disturbance

The continuous disturbance voltage of AC Mains in the frequency from 0.15 to 30 MHz was measured in accordance to FCC Part 15 (2007) & ANSI C 63.4 (2003) The test setup was made according to FCC Part 15 (2007) & ANSI C 63.4 (2003) in a shielded. The EUT was placed on a non-conductive table at least 80 above the ground plan. A grounded vertical reference plane was positioned in a distance of 40cm from the EUT. The distance from the EUT to other metal surfaces was at least 0.8m. The EUT was only earthen by its power cord through the line impedance stabilizing network. The power cord has been bundled to a length of 1.0m.. The test receiver with Quasi Peak detector complies with CISPR 16.

11.1 Measurement equipments

Equipment Name	Type	Manufacturer	Serial No.	Next Calibration date
LISN	NNLA8120A	Schwarzbeck	8120161	2010. 2. 21
LISN	ESH3-Z5	Schwarzbeck	838979/010	2010. 2. 21
TEST Receive	ESPI7	Rohde & Schwarz	100185	2009. 8. 27
Pulse Limiter	ESH3Z2	Rohde & Schwarz	NONE	2009. 9. 10

11.2 Environmental Condition

Test Place : Shield Room
 Temperature (°C) : 21
 Humidity (%) : 37 %



ESTECH Co., Ltd.

Rm 1015, World Venture Center II,
426-5 Gasan-dong, Gangcheon-gu,
Seoul, 158-803, Korea



**Electromagnetic
Interference
Test Report**

11.3 Test data(CH39)

Test Date : 24-Mar-09

Frequency (MHz)	Correction Factor		Line (H/N)	Quasi-peak Value			Average Value		
	Lisn (dB)	Cable (dB)		Limit (dB μ V)	Reading (dB μ V)	Result (dB μ V)	Limit (dB μ V)	Reading (dB μ V)	Result (dB)
0.15	0.09	0.2	N	65.94	32.74	33.06	55.94	21.93	22.25
0.19	0.09	0.2	N	63.86	35.92	36.24	53.86	25.10	25.42
0.20	0.09	0.2	N	63.74	35.96	36.28	53.74	24.69	25.01
0.25	0.09	0.2	N	61.63	30.68	31.00	51.63	22.55	22.87
0.27	0.09	0.2	N	61.24	29.98	30.30	51.24	22.84	23.16
0.40	0.10	0.3	H	57.79	30.13	30.52	47.79	23.05	23.44
0.47	0.10	0.3	N	56.58	28.93	29.37	46.58	21.40	21.84
0.52	0.10	0.4	N	56.00	24.89	25.35	46.00	19.13	19.59
1.70	0.13	0.4	H	56.00	26.04	26.62	46.00	19.31	19.89
2.11	0.14	0.4	H	56.00	27.04	27.61	46.00	18.51	19.08
2.16	0.14	0.4	N	56.00	28.58	29.15	46.00	19.42	19.99
7.95	0.33	0.8	N	60.00	27.84	28.97	50.00	21.19	22.32
Remark	H : Hot Line, N : Neutral Line TEST MODE : CH 39 (2441MHz)								



12. Antenna Requirement

12.1 Standard Applicable

For intentional device, according to FCC 47 CFR Section 15.203, an intentional radiator shall be designed to ensure that no antenna other than that furnished by the responsible party shall be used with the device.

And according to FCC 47 CFR Section 15.24

12.2 Antenna Connected Construction

The antenna types used in this product are Multilayer Chip Antenna. The maximum Gain of this antenna is 2.0dBi.

Appendix 1. Spectral diagram

*HOT

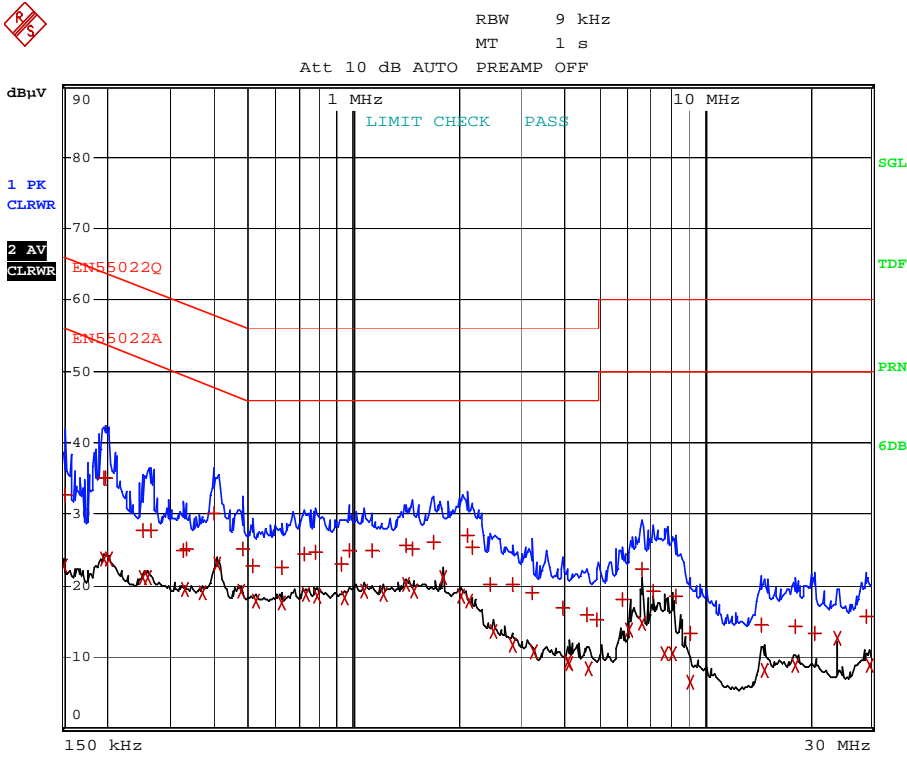

Comment: KDC300 HOT
Date: 24.MAR.2009 09:07:20

*NEUTRAL

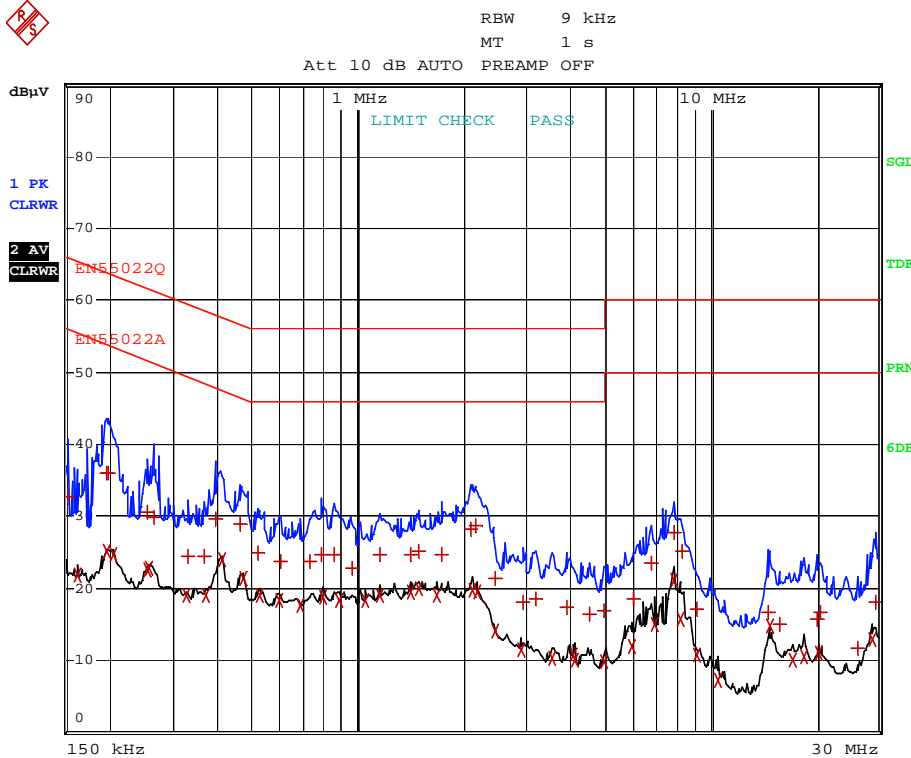

Comment: KDC300 NEUTRAL
Date: 24.MAR.2009 09:15:50