

## Electromagnetic Emission

# FCC MEASUREMENT REPORT

## CERTIFICATION OF COMPLIANCE

### FCC Part 15 Certification Measurement

**PRODUCT** : Barcode Scanner(Bluetooth/GPS)  
**MODEL/Serial No.** : KDC250 / Proto type  
**MULTIPLE MODEL** : -  
**FCC ID** : VH9KDC250  
**APPLICANT** : AISOLUTION CO., LTD.  
Astar Bldg., 1F, 318-3 Yangjae-Dong, Seocho-Gu, Seoul, Korea  
Attn.: Hanjin Lee / CEO  
**MANUFACTURER** : AISOLUTION CO., LTD.  
Astar Bldg., 1F, 318-3 Yangjae-Dong, Seocho-Gu, Seoul, Korea  
**FCC CLASSIFICATION** : DSS (Part 15 Spread Spectrum Transmitter)  
**TYPE OF MODULATION** : FHSS (GFSK (Normal), PSK (EDR))  
**FREQUENCY CHANNEL** : 2 402 MHz to 2 480 MHz and Channel Spacing 1 MHz (79 Ch)  
**AIR DATE RATE** : Normal (1 Mbps), EDR (3 Mbps)  
**ANTENNA TYPE** : Chip Antenna (Integral)  
**ANTENNA GAIN** : 2.70 dBi max  
**RF POWER** : 0.729 mW  
**RULE PART(S)** : FCC Part 15 Subpart C  
**FCC PROCEDURE** : ANSI C63.4-2003  
**TEST REPORT No.** : ETLE110513.0406  
**DATES OF TEST** : June 20, 2011 to June 24, 2011  
**REPORT ISSUE DATE** : July 18, 2011  
**TEST LABORATORY** : ETL Inc. (FCC Designation Number : KR0022)

The Barcode Scanner(Bluetooth/GPS), Model KDC250 has been tested in accordance with the measurement procedures specified in ANSI C63.4-2003 at the ETL Test Laboratory and has been shown to be complied with the electromagnetic radiated emission limits specified in FCC Rule Part15 Subpart C section 15.247.

I attest to the accuracy of data. All measurement herein was performed by me or was made under my supervision and is correct to the best of my knowledge and belief. I assume full responsibility for the completeness of these measurements and vouch for the qualifications of all persons taking them.

The results of testing in this report apply to the product/system which was tested only. Other similar equipment will not necessarily produce the same results due to production tolerance and measurement uncertainties.

Prepared by:   
Jeong Hwan, Pyo (Test Engineer)  
July 18, 2011

Reviewed by:   
Yo Han, Park (Chief Engineer)  
July 18, 2011

**ETL Inc.**

**#371-51, Gasan-dong, Geumcheon-gu, Seoul, 153-803, Korea**

**Tel: 82-2-858-0786 Fax: 82-2-858-0788**

*The test report merely corresponds to the test sample(s).*

*This report shall not be reproduced, in whole or in part without the written approval of ETL Inc.*

## Table of Contents

### **FCC Measurement Report**

- 1. Introduction**
- 2. Product Information**
- 3. Description of Tests**
- 4. Test Condition**
- 5. Test Results**
  - 5.1 Summary of Test Results**
  - 5.2 Channel Bandwidth and Frequency Separation**
  - 5.3 Maximum Peak Output Power**
  - 5.4 Bandwidth of Frequency Band Edges**
  - 5.5 Number of Hopping Channels**
  - 5.6 Time of Occupancy (Dwell time)**
  - 5.7 Spurious Emissions**
  - 5.8 Conducted Emissions Test**
  - 5.9 Radio Frequency Exposure**
- 6. Sample Calculation**
- 7. List of test Equipment used for Measurement**

**Appendix A. FCC ID Label and Location**

**Appendix B. Test Setup Photographs**

**Appendix C. External Photographs**

**Appendix D. Internal Photographs**

**Appendix E. Block Diagram**

**Appendix F. Circuit Diagram**

**Appendix G. User Manual**

**Appendix H. Operational Description**

**Appendix I. Antenna Requirement**

**Appendix J. Radio Frequency Exposure**

## FCC MEASUREMENT REPORT

**Scope** – Measurement and determination of electromagnetic emission (EME) of radio frequency devices including intentional radiators and/or unintentional radiators for compliance with the technical rules and regulations of the U.S Federal Communications Commission(FCC)

### General Information

|                       |   |
|-----------------------|---|
| <b>Applicant Name</b> | <b>: AISOLUTION CO., LTD.</b>   |
| <b>Address</b>        | <b>: Astar Bldg., 1F, 318-3 Yangjae-Dong, Seocho-Gu, Seoul, Korea</b> |
| <b>Attention</b>      | <b>: Hanjin Lee / CEO</b>   |

- **EUT Type** : Barcode Scanner(Bluetooth/GPS)
- **Model Number** : KDC250
- **S/N** : Proto type
- **Freq. Range** : 2 402 MHz - 2 480 MHz
- **Number of Channels** : 79
- **Modulation Technique** : FHSS (GFSK (Normal), PSK (EDR))
- **Frequency Channel** : 2 402 MHz to 2 480 MHz and Channel Spacing 1 MHz (79 Ch)
- **Air Data Rate** : Normal (1 Mbps), EDR (3 Mbps)
- **Antenna Type** : Chip Antenna (Integral)
- **Antenna Gain** : 2.70 dBi max
- **RF Power** : 0.729 mW
- **FCC Rule Part(s)** : FCC Part 15 Subpart C
- **Test Procedure** : ANSI C63.4-2003
- **FCC Classification** : DSS (Part 15 Spread Spectrum Transmitter)
- **Place of Tests** : ETL Inc. Testing Lab.  
Radiated Emission test;  
#499-1, Sagot-ri, Seosin-myeon, Hwaseong-si, Gyeonggi-do,  
445-882, Korea  
  
Conducted Emission test;  
ETL Inc. Testing Lab.  
371-51, Gasan-dong, Geumcheon-gu, Seoul, 153-803, Korea

## **1. INTRODUCTION**

The measurement test for radiated and conducted emission test was conducted at the ETL Inc. The site is constructed in conformance with the requirements of the ANSI C63.4-2003 and CISPR Publication 16. The ETL has site descriptions on file with the FCC for 3 m and 10 m site configurations. Detailed description of test facility was found to be in compliance with FCC Rules according to the ANSI C63.4-2003 and registered to the Federal Communications Commission (FCC Designation Number : KR0022).

The measurement procedure described in American National Standard for Method of Measurement of Radio-Noise Emission from Low-Voltage Electrical and Electronic Equipment in the Range of 9 kHz to 40 GHz (ANSI C63.4-2003) was used in determining radiated and conducted emissions from the AISOLUTION CO., LTD. Model: KDC250

## 2. PRODUCT INFORMATION

### 2.1 Equipment Description

The Equipment Under Test (EUT) is the Barcode Scanner(Bluetooth/GPS) (model: KDC250).

### 2.2 General Specification

**- General Specification**

| Item                                      |   | Specification                                       |
|---|---|---|
| Hardware Specification                    | Physical Characteristics  | Size: 1.45" x 3.26" x 0.82" (37 mm x 83 mm x 21 mm) |
|   |   | Weight: 2.0 oz. (57 g)                              |
|   | Electrical Characteristics  | Battery: Lithium-Ion (3.7 V DC, 650 mAh)            |
|   |   | Charging: Via USB connector                         |
|   |   | Typical Operating Current: 170 mA @ 3.3 V           |
|   | Scanning Performance  | Scan Rate: 100 scans/sec                            |
|   | GPS   | PT9250 48 channel GPS Receiver                      |
|   | User Environment  | Drop Spec: 4 feet (1.22 m) with Rubber Case         |
|   |   | Operating: (72.5 ± 40.5) °F ((22.5 ± 22.5) °C)      |
|   |   | Storage: (54.5 ± 58.5) °F (12.5 ± 32.5) °C)         |
|   |   | Humidity: (45 ± 40) % R.H. (noncondensing)          |
|   | Interfaces  | Bluetooth@V2.1+EDR, Class 2,                        |
|   |   | HID/SPP/MFi(i model only)                           |
|   |   | USB to Serial (Ultra mini USB port)                 |
|   | Functionality   | Memory Flash ROM: 256 kB Program, 4 MB User Data    |
|   |   | Memory RAM: 64 kB                                   |
| Microprocessor: ARM7, 32 bit              |   |   |
| Real-time Clock: Quartz RTC for timestamp |   |   |
| Symbologies                               | EAN, UPC, Code 39, Code 93, Code 128, Codabar, Interleaved 2 of 5, GS1-128, Code 3 of 5 |   |
| Wedging & Synchronization                 | Store to a file or transfer to the application  |   |
|   | Keyboard wedge function   |   |
|   | Add-on prefixes and suffixes  |   |
|   | Barcode option selection  |   |

| Item                   | Specification                              |
|------------------------|--|
| Application Generation | SDK for PC, Pad and Smartphone application |
|                        | Application generation tool                |
|                        | Database lookup feature                    |
|                        | Inventory management feature               |

**- Bluetooth Specification**

| Item      | Specification                          |
|-----------|--|
| Bluetooth | Operating Freq.: 2 402 MHz ~ 2 480 MHz |
|           | Freq. Channel: 79 (CH space: 1 MHz)    |
|           | Modulation method: GFSK, PSK (EDR)     |
|           | Oscillation method: PLL                |

**- Frequency Channel Table**

| CH | MHz  | CH | MHz  | CH | MHz  | CH | MHz  | CH | MHz  | CH | MHz  | CH | MHz  | CH | MHz  |
|----|------|----|------|----|------|----|------|----|------|----|------|----|------|----|------|
| 1  | 2402 | 11 | 2412 | 21 | 2422 | 31 | 2432 | 41 | 2442 | 51 | 2452 | 61 | 2462 | 71 | 2472 |
| 2  | 2403 | 12 | 2413 | 22 | 2423 | 32 | 2433 | 42 | 2443 | 52 | 2453 | 62 | 2463 | 72 | 2473 |
| 3  | 2404 | 13 | 2414 | 23 | 2424 | 33 | 2434 | 43 | 2444 | 53 | 2454 | 63 | 2464 | 73 | 2474 |
| 4  | 2405 | 14 | 2415 | 24 | 2425 | 34 | 2435 | 44 | 2445 | 54 | 2455 | 64 | 2465 | 74 | 2475 |
| 5  | 2406 | 15 | 2416 | 25 | 2426 | 35 | 2436 | 45 | 2446 | 55 | 2456 | 65 | 2466 | 75 | 2476 |
| 6  | 2407 | 16 | 2417 | 26 | 2427 | 36 | 2437 | 46 | 2447 | 56 | 2457 | 66 | 2467 | 76 | 2477 |
| 7  | 2408 | 17 | 2418 | 27 | 2428 | 37 | 2438 | 47 | 2448 | 57 | 2458 | 67 | 2468 | 77 | 2478 |
| 8  | 2409 | 18 | 2419 | 28 | 2429 | 38 | 2439 | 48 | 2449 | 58 | 2459 | 68 | 2469 | 78 | 2479 |
| 9  | 2410 | 19 | 2420 | 29 | 2430 | 39 | 2440 | 49 | 2450 | 59 | 2460 | 69 | 2470 | 79 | 2480 |
| 10 | 2411 | 20 | 2421 | 30 | 2431 | 40 | 2441 | 50 | 2451 | 60 | 2461 | 70 | 2471 |    |      |

## 3. DESCRIPTION OF TESTS

The tests documented in this report were performed in accordance with ANSI C63.4-2003 and FCC CFR 47 2.1046, 2.1047, 2.1049, 2.1051, 2.1053, 2.1055, 2.1057, 15.207, 15.209 and 15.247.

### 3.1 Radiated Emission Measurement

Radiated emission measurements were made in accordance with § 13 in ANSI C63.4-2003 "Measurement of Intentional radiators" The measurements were performed over the frequency range of 30 MHz to 40 GHz using antenna as the input transducer to a Spectrum analyzer or a Field Intensity Meter. The measurements were made with the detector set for "Peak, Quasi-peak, Average" within a bandwidth of 120 kHz and above 1 GHz is 1 MHz.

Preliminary measurements were made at 3 m using broadband antennas, and spectrum analyzer to determine the frequency producing the maximum emission in shielded room. Appropriate precaution was taken to ensure that all emission from the EUT were maximized and investigated. The system configuration, mode of operation, turntable azimuth and height with respect to the antenna were noted for each frequency found. The spectrum was scanned from 30 MHz to 1 000 MHz using Log-Bicon antenna. Above 1 GHz, linearly polarized double ridge horn antennas were used. Final measurements were made open site at 3 m. The test equipment was laced on a wooden turn-table. Sufficient time for the EUT, support equipment, and test equipment was allowed in order for them to warm up to their normal operating condition. Each frequency found during pre-scan measurements was re-examined by manual. The detector function was set to CISPR Quasi-peak mode and the bandwidth of the receiver was set to 120 kHz or 1 MHz depending on the frequency of type of signal. The EUT, support equipment and interconnecting cables were re-configured to the set-up producing the maximum emission for the frequency and were placed on top of a 0.8 m high nonmetallic 1.0 m x 1.5 m table. The EUT, support equipment, and interconnecting cables were re-arranged and manipulated to maximize each emission. The turntable containing the system was rotated; the antenna height was varied 1 m to 4 m and stopped at the azimuth or height producing the maximum emission.

Varying the mode of operating frequencies of the EUT maximized each emission. The system was tested in all the three orthogonal planes and changing the polarity of the antenna. The worst-case emissions are recorded in the data tables. If necessary, the radiated emission measurement could be performed at a closer distance to ensure higher accuracy and the results were extrapolated to the specified distance using an inverse linear distance extrapolation factor (20 dB/decade) as per section 15.31(f).

Photographs of the worst-case emission can be seen in Photographs of the worst-case emission test setup can be seen in Appendix B.

## 3.2 Conducted Emission Measurement

Conducted emissions measurements were made in accordance with section § 13 in ANSI C63.4-2003 "measurement of intentional radiators" The measurements were performed over the frequency range of 0.15 MHz to 30 MHz using a 50  $\Omega$ /50  $\mu$ H LISN as the input transducer to a Spectrum Analyzer or a Test Receiver. The measurements were made with the detector set for "Peak" amplitude within a bandwidth of 9 kHz or for "quasi-peak" within a bandwidth of 9 kHz.

The line-conducted emission test is conducted inside a shielded anechoic chamber room with 1 m x 1.5 m x 0.8 m wooden table which is placed 0.4 m away from the vertical wall and 1.5 m away from the side wall of the chamber room. Two LISN are bonded to the shielded room. The EUT is powered from the LISN and the support equipment is powered from the other LISN. Power to the LISNs are filtered by a noise cut power line filters. All electrical cables are shielded by braided tinned steel tubing with inner  $\phi$  1.2 cm. If the EUT is a DC-powered device, power will be derived from the source power supply it normally will be powered from and these supply lines will be connected to the LISN. Non-inductive bundling to a 1 m length shortened all interconnecting cables more than 1 m. Sufficient time for the EUT, support equipment, and test equipment was allowed in order for them to warm up to their normal operating condition. The RF output of the LISN was connected to the EMI Test Receiver to determine the frequency producing the maximum emission from the EUT. The frequency producing the maximum level was reexamined using to set Quasi-Peak mode by manual, after scanned by automatic Peak mode from 0.15 MHz to 30 MHz. The bandwidth of the spectrum analyzer was set to 9 kHz. The EUT, support equipment, and interconnecting cables were arranged and manipulated to maximize each emission.

Photographs of the worst-case emission can be seen in Photographs of the worst-case emission test setup can be seen in Appendix B.



### 3.3 FCC Part 15.205 Restricted Bands of Operations

(a) Except as shown in paragraph (d) of this section, only spurious emissions are permitted in any of the frequency bands listed below:

| MHz                        | MHz                   | MHz               | GHz              |
|----------------------------|-----------------------|-------------------|------------------|
| 0.090 - 0.110              | 16.42 - 16.423        | 399.9 - 410       | 4.5 - 5.15       |
| <sup>1</sup> 0.495 - 0.505 | 16.694 75 - 16.695 25 | 608 - 614         | 5.35 - 5.46      |
| 2.173 5 - 2.190 5          | 16.804 25 - 16.804 75 | 960 - 1 240       | 7.25 - 7.75      |
| 4.125 - 4.128              | 25.5 - 25.67          | 1 300 - 1 427     | 8.025 - 8.5      |
| 4.177 25 - 4.177 75        | 37.5 - 38.25          | 1 435 - 1 626.5   | 9.0 - 9.2        |
| 4.207 25 - 4.207 75        | 73 - 74.6             | 1 645.5 - 1 646.5 | 9.3 - 9.5        |
| 6.215 - 6.218              | 74.8 - 75.2           | 1 660 - 1 710     | 10.6 - 12.7      |
| 6.267 75 - 6.268 25        | 108 - 121.94          | 1 718.8 - 1 722.2 | 13.25 - 13.4     |
| 6.311 75 - 6.312 25        | 123 - 138             | 2 200 - 2 300     | 14.47 - 14.5     |
| 8.291 - 8.294              | 149.9 - 150.05        | 2 310 - 2 390     | 15.35 - 16.2     |
| 8.362 - 8.366              | 156.7 - 156.9         | 2 483.5 - 2 500   | 17.7 - 21.4      |
| 8.376 25 - 8.386 75        | 156.7 - 156.9         | 2 690 - 2 900     | 22.01 - 23.12    |
| 8.414 25 - 8.414 75        | 162.012 5 - 167.17    | 3 260 - 3 267     | 23.6 - 24.0      |
| 12.29 - 12.293             | 167.72 - 173.2        | 3 332 - 3 339     | 31.2 - 31.8      |
| 12.519 75 - 12.520 25      | 240 - 285             | 3 345.8 - 3 358   | 36.43 - 36.5     |
| 12.576 75 - 12.577 25      | 322 - 335.4           | 3 600 - 4 400     | ( <sup>2</sup> ) |
| 13.36 - 13.41              |                       |                   |                  |

<sup>1</sup> Until February 1, 1999, this restricted band shall be 0.490 MHz - 0.510 MHz.

<sup>2</sup> Above 38.6

(b) Except as provided in paragraphs (d) and (e), the field strength of emissions appearing within these frequency bands shall not exceed the limits shown in Section 15.209. At frequencies equal to or less than 1 000 MHz, compliance with the limits in Section 15.209 shall be demonstrated using measurement instrumentation employing a CISPR quasi-peak detector. Above 1 000 MHz, compliance with the emission limits in Section 15.209 shall be demonstrated based on the average value of the measured emissions. The provisions in Section 15.35 apply to these measurements.

## 4. TEST CONDITION

### 4.1 Test Configuration

The device was configured for testing in a typical fashion (as a customer would normally use it). During the tests, the following conditions and configurations were used.

### 4.2 Description of Test modes

Barcode Scanner(Bluetooth/GPS) that has the control software.

### 4.3 The setup drawing(s)

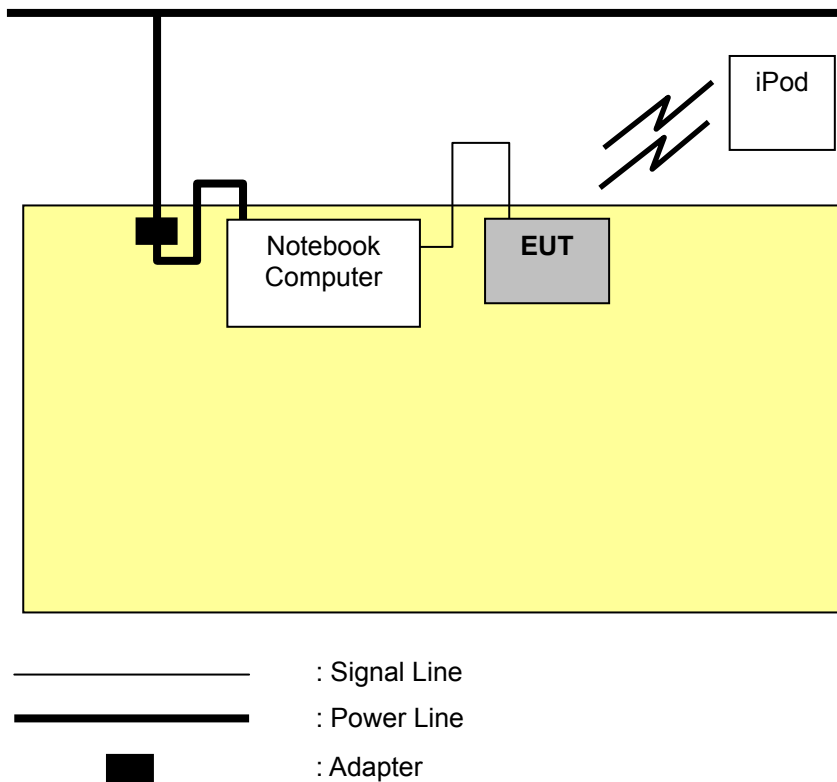

## 5. TEST RESULTS

### 5.1 Summary of Test Results

The measurement results were obtained with the EUT tested in the conditions described in this report. Detailed measurement data and plots showing the maximum emission of the EUT are reported.

| 47 CFR Part 15, Subpart C | Measurement Required                    | Result |
|---------------------------|---|--------|
| 15.247(a)(1)              | Channel Bandwidth, Frequency Separation | Pass   |
| 15.247(b)(3)              | Maximum Peak Output Power               | Pass   |
| 15.247(d)                 | Bandwidth of Frequency Band Edges       | Pass   |
| 15.247(a)(1)(iii)         | Number of Hopping Channels              | Pass   |
| 15.247(a)(1)(iii)         | Time of Occupancy (Dwell time)          | Pass   |
| 15.209(a)                 | Spurious Emissions                      | Pass   |
| 15.207                    | Conducted Emissions                     | Pass   |
| 15.247(i)<br>1.1307(b)(1) | RF Exposure                             | Pass   |

The data collected shows that the **AISOLUTION CO., LTD. / Barcode Scanner(Bluetooth/GPS) / KDC250** complied with technical requirements of above rules part 15.207, 209 and 15.247 Limits.

The equipment is not modified anything, mechanical or circuits to improve EMI status during a measurement. No EMI suppression device(s) was added and/or modified during testing.

## 5.2 Channel Bandwidth and Frequency Separation

|                     |   |
|---------------------|---|
| EUT                 | Barcode Scanner(Bluetooth/GPS) / KDC250         |
| Limit apply to      | FCC Part 15.247(a)(1)                           |
| Test Date           | June 24, 2011                                   |
| Operating Condition | RF transmitting continuously during the tested. |
| Result              | Passed  |

### 5.2.1 Channel Bandwidth

| Type of Modulation | Frequency [MHz] | 20 dB Bandwidth [MHz] | Limit  |
|--------------------|-----------------|-----------------------|--|
| GFSK               | 2 402           | 0.943                 | 2/3 of the 20 dB Bandwidth<br>< Carrier frequency separation |
|                    | 2 441           | 0.947                 |  |
|                    | 2 480           | 0.930                 |  |
| 8DPSK              | 2 402           | 1.260                 |  |
|                    | 2 441           | 1.260                 |  |
|                    | 2 480           | 1.260                 |  |

NOTES:

1. Measure frequency separation of relevant channel using spectrum analyzer.
2. Please see the measured plot in next page.

### 5.2.2 Frequency Separation

Frequency hopping systems shall have hopping channel carrier frequencies separated by a minimum of 25 kHz or the 20 dB bandwidth of the hopping channel, whichever is greater.

| Type of Modulation | EUT Channel Separation [MHz] | 20 dB bandwidth [MHz] | Limit                                    |
|--------------------|------------------------------|-----------------------|--|
| GFSK               | 1.000 (Worst)                | 0.947 (Worst)         | > 25 kHz or > 2/3 of the 20 dB Bandwidth |
| 8DPSK              | 0.992 (Worst)                | 1.260 (Worst)         |  |

NOTES:

1. Measure frequency separation of relevant channel using spectrum analyzer.
2. Please see the measured plot in next page.

## Plots of 20 dB Bandwidth (GFSK)

[2 402 MHz]

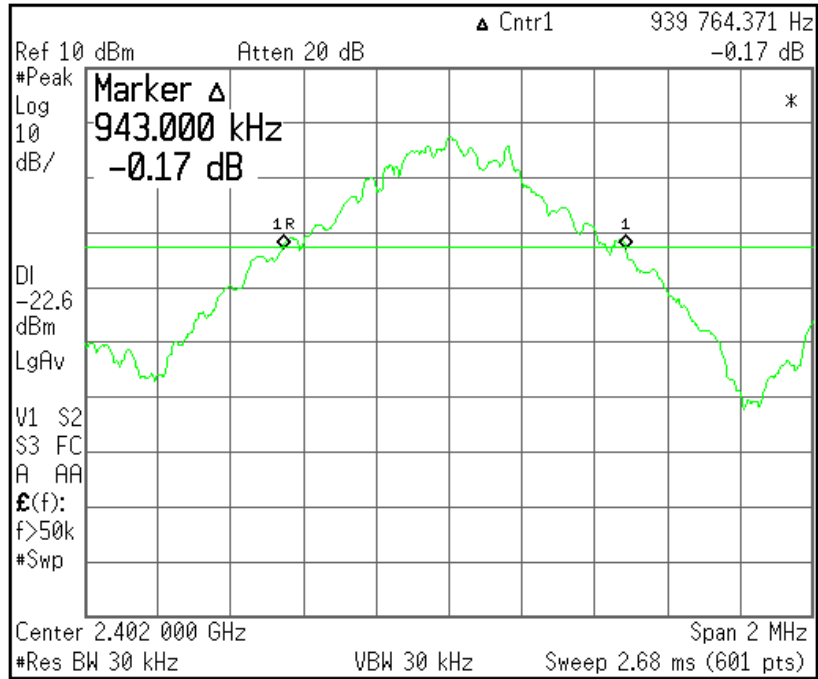

[2 441 MHz]

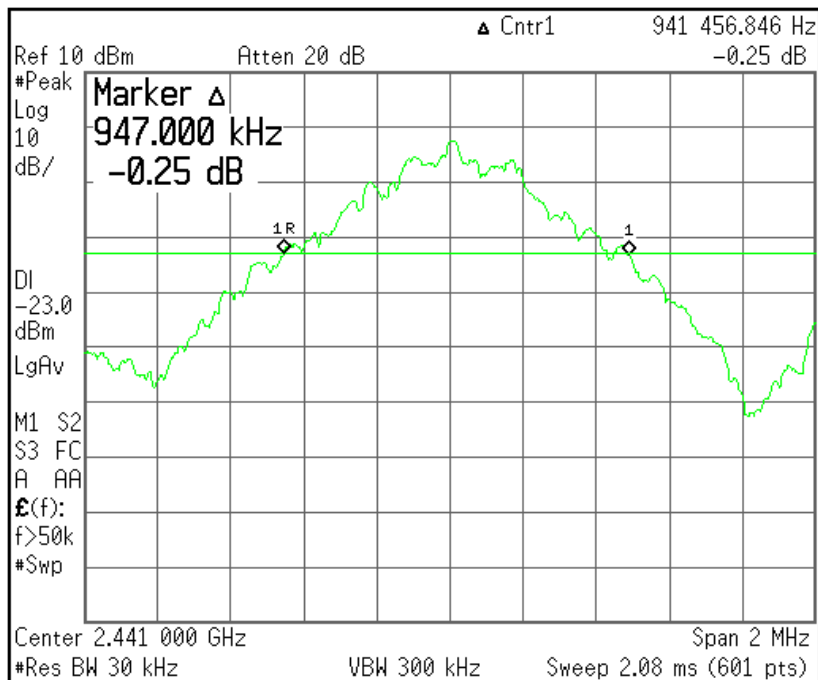

[2 480 MHz]

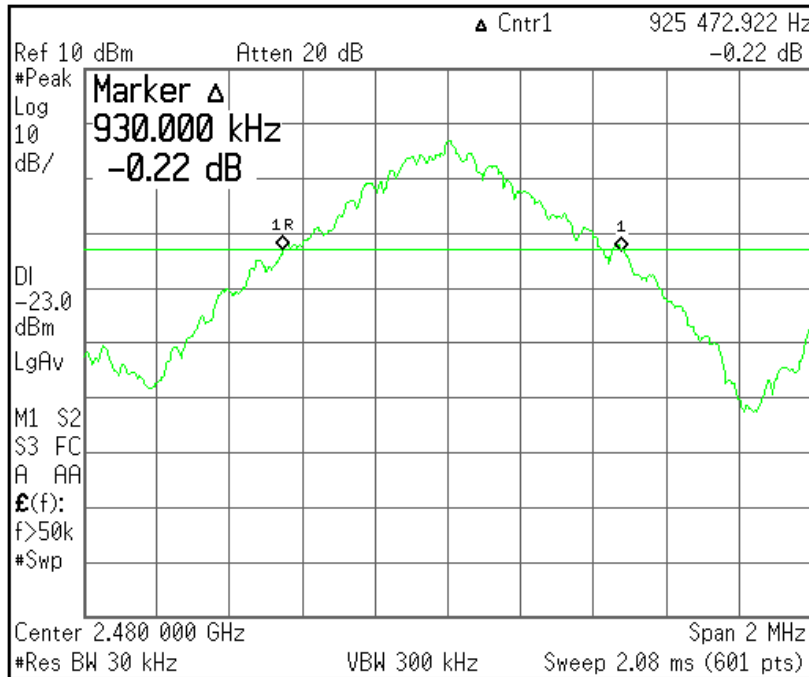

## Plots of Frequency Separation (GFSK)

[Channel Separation]

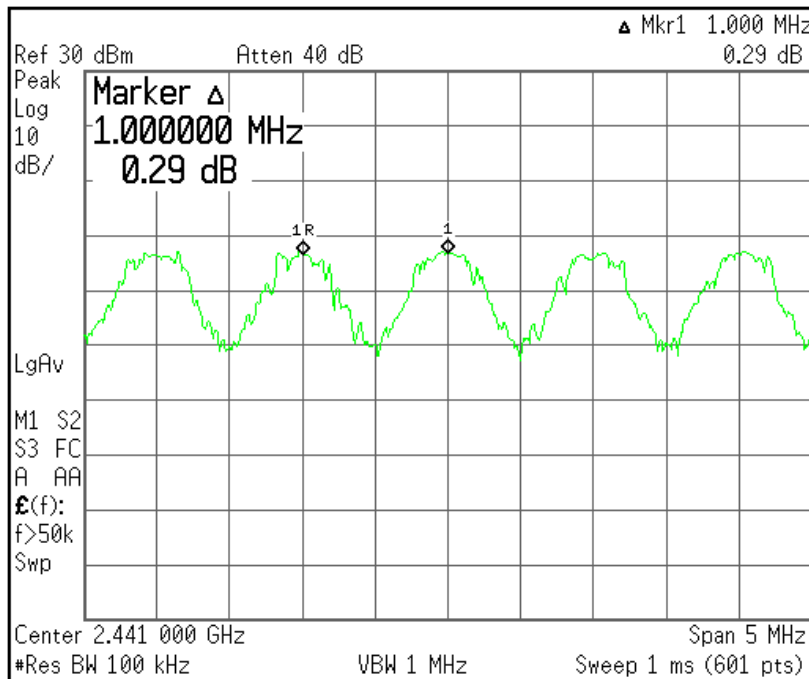

## Plots of 20 dB Bandwidth (8DPSK)

[2 402 MHz]

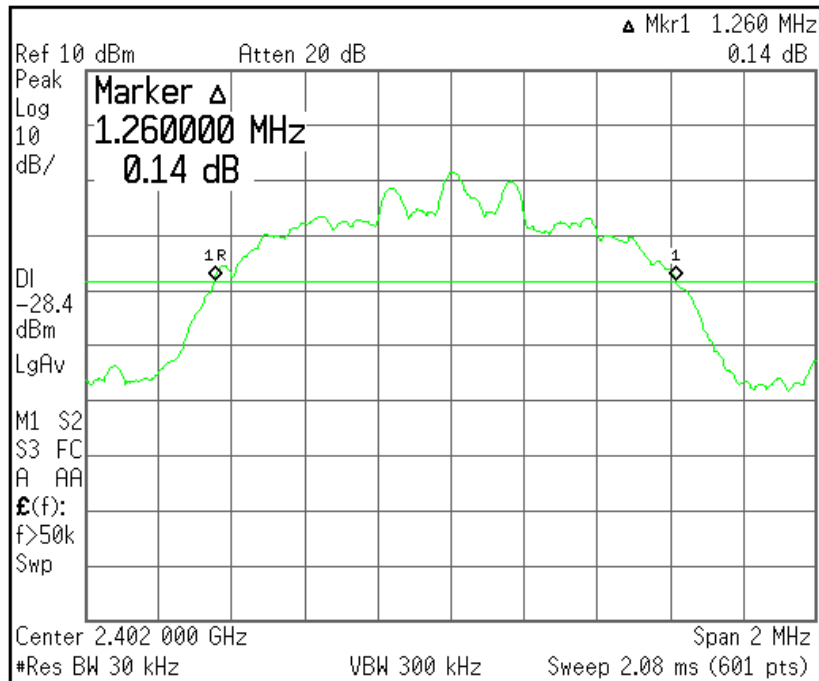

[2 441 MHz]

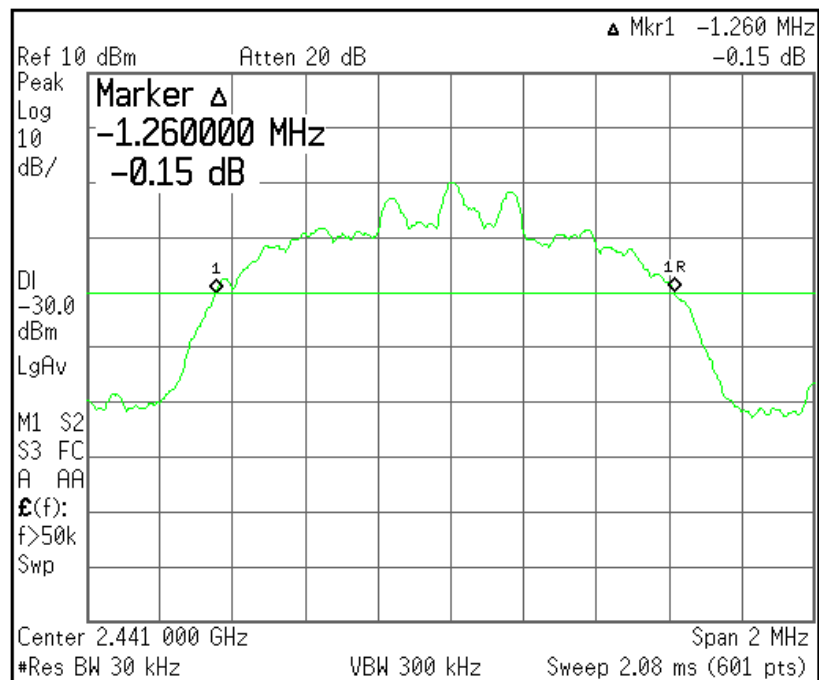

[2 480 MHz]

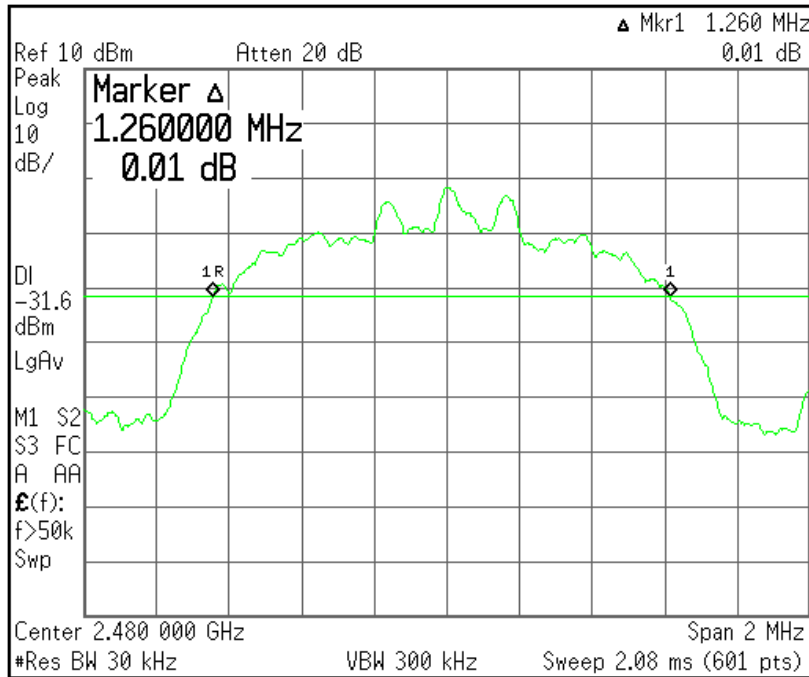

## Plots of Frequency Separation (8DPSK)

[Channel Separation]

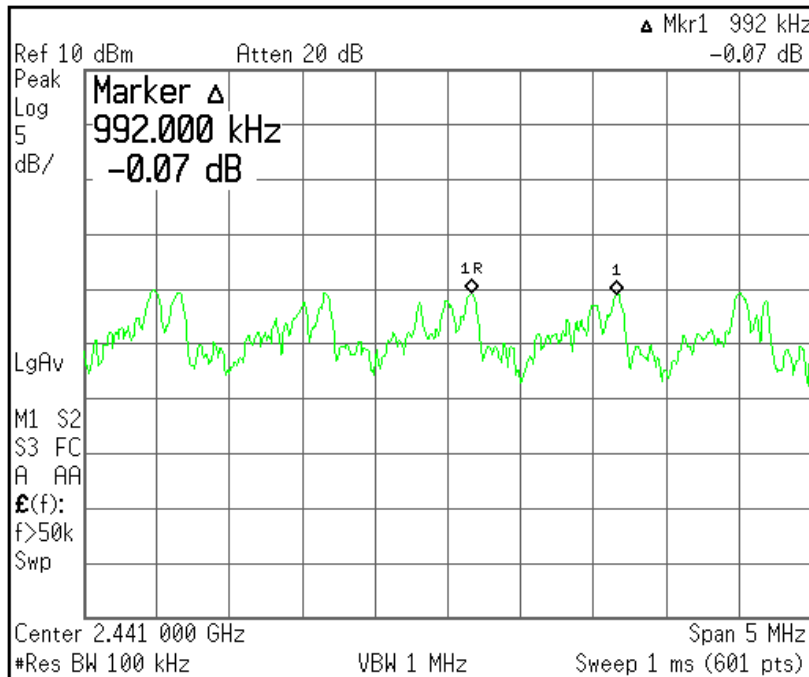



## 5.3 Maximum Peak Conducted Output Power

|                     |   |
|---------------------|---|
| EUT                 | Barcode Scanner(Bluetooth/GPS) / KDC250         |
| Limit apply to      | FCC Part 15.247(b)(3)                           |
| Test Date           | June 24, 2011                                   |
| Operating Condition | RF transmitting continuously during the tested. |
| Result              | Passed  |

### Limit

The maximum peak conducted output power of the intentional radiator shall not exceed the following:

For frequency hopping systems operating in the 2 400.0 MHz - 2 483.5 MHz band employing at least 75 non-overlapping hopping channels: 1 Watt

### Test Data

| Type of Modulation | Channel | Frequency [MHz] | Output Power [dBm] | Limit             |
|--------------------|---------|-----------------|--------------------|-------------------|
| GFSK               | Low     | 2 402           | -1.37              | < 30.00 dBm (1 W) |
|                    | Mid     | 2 441           | -1.66              |                   |
|                    | High    | 2 480           | -2.27              |                   |
| 8DPSK              | Low     | 2 402           | -7.81              |                   |
|                    | Mid     | 2 441           | -9.30              |                   |
|                    | High    | 2 480           | -10.74             |                   |

Maximum measured transmitter power (for RF Exposure):

| Type of Modulation | Output Power |       | Max Antenna Gain [dBi] | EIRP [mW] |
|--------------------|--------------|-------|------------------------|-----------|
|                    | [dBm]        | [mW]  |                        |           |
| GFSK               | -1.370       | 0.729 | 2.700                  | 1.358     |
| 8DPSK              | -7.810       | 0.091 | 2.700                  | 0.308     |

- Theory value for RF Exposure

$$P_{e.i.r.p.}(mW) = A_{cond} (dBm) + G_{assembly\ antenna\ gain} (dBi)$$

### NOTES:

1. Measure conducted Channel power of relevant channel using Spectrum analyzer
2. RBW 1 MHz, VBW 1 MHz
3. Please see the measured plot in next page.

## Plots of Maximum Peak Output Power (GFSK)

[2 402 MHz]

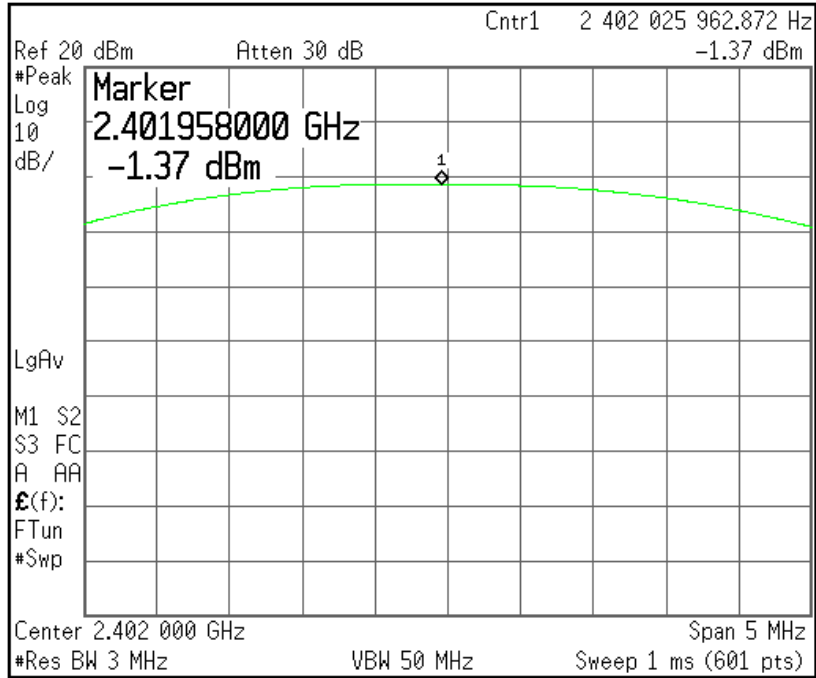

[2 441 MHz]

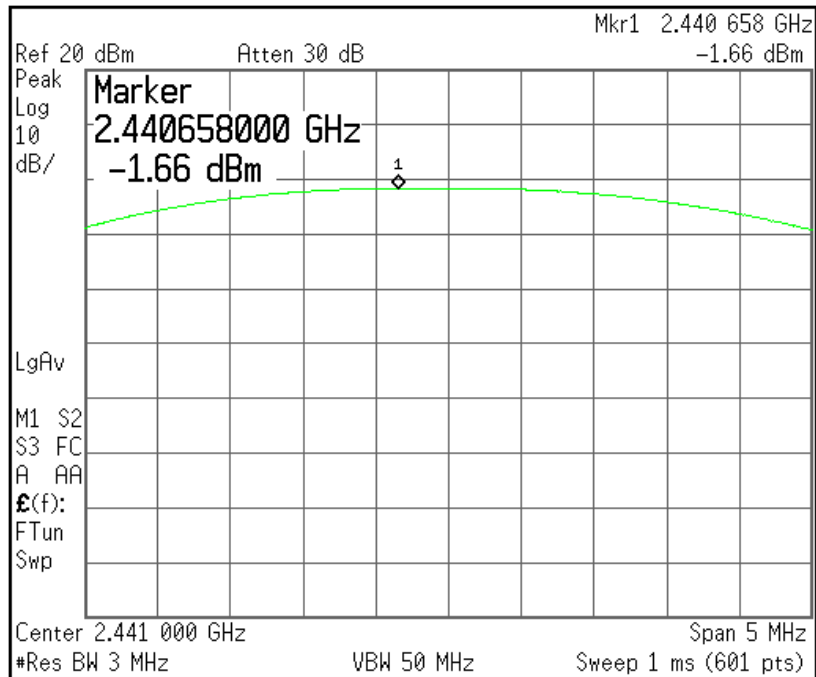

[2 480 MHz]

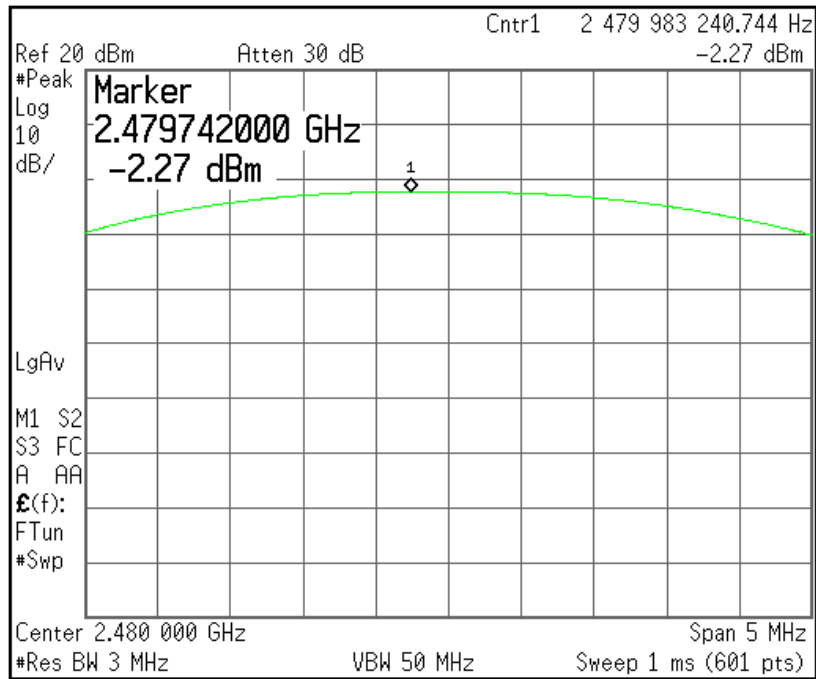

## Plots of Maximum Peak Output Power (8DPSK)

[2 402 MHz]

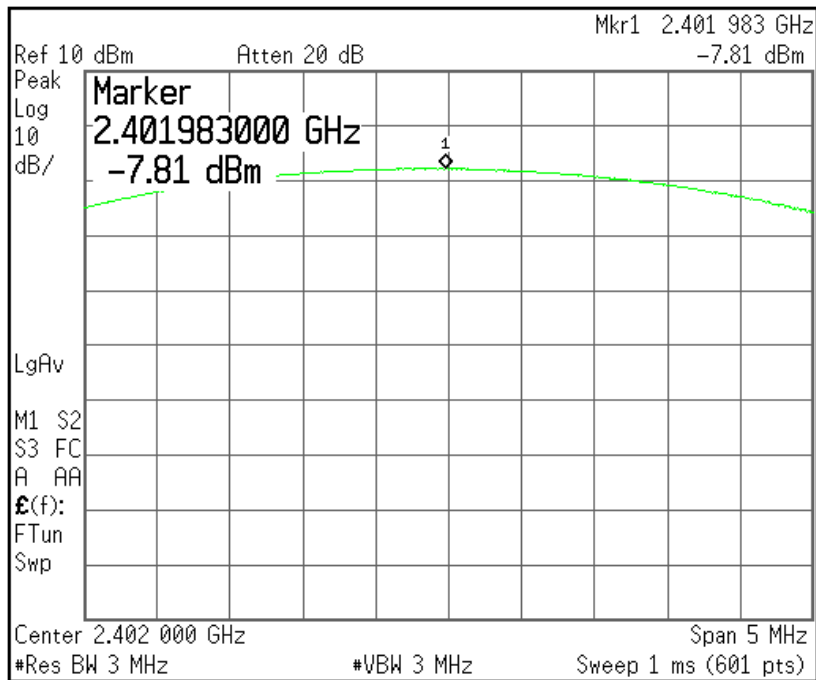

[2 441 MHz]

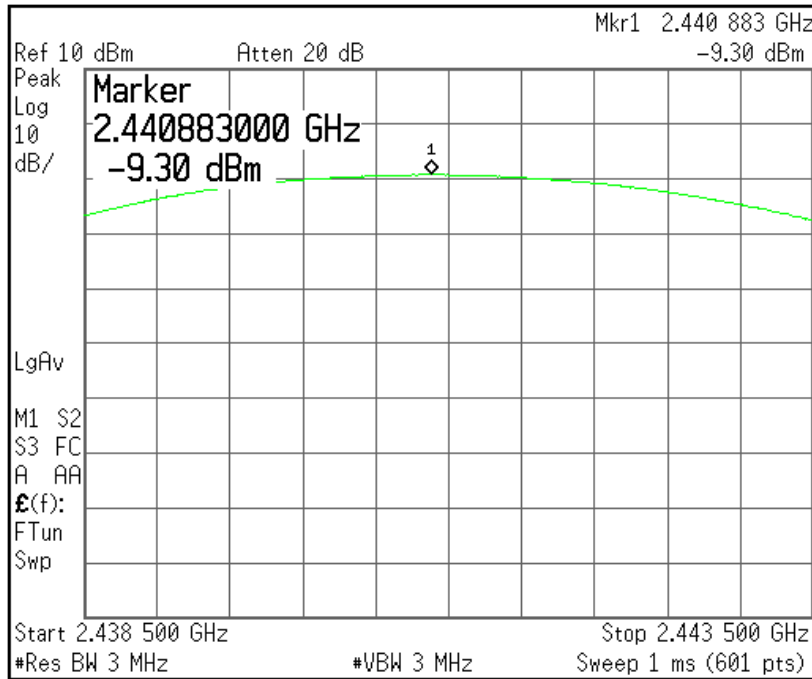

[2 480 MHz]

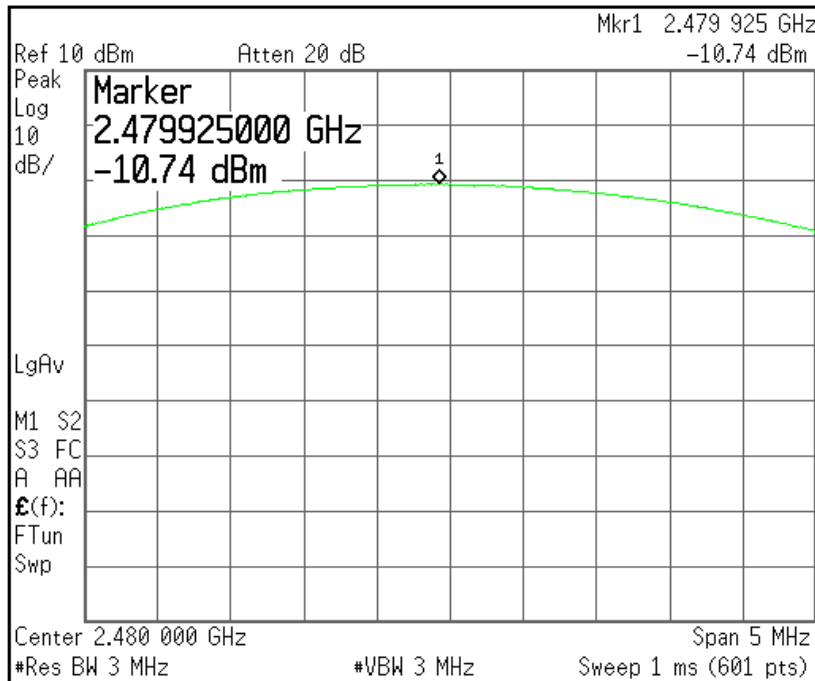

## 5.4 Bandwidth of Frequency Band Edges

|                     |   |
|---------------------|---|
| EUT                 | Barcode Scanner(Bluetooth/GPS) / KDC250         |
| Limit apply to      | FCC Part 15.247(d)                              |
| Test Date           | June 20, 2011 to June 24, 2011                  |
| Operating Condition | RF transmitting continuously during the tested. |
| Result              | Passed  |

### Limit

In any 100 kHz bandwidth outside the frequency band in which the spread spectrum or digitally modulated intentional radiator is operating, the radio frequency power that is produced by the intentional radiator shall be at least 20 dB below that in the 100 kHz bandwidth within the band that contains the highest level of the desired power, based on either an RF conducted or a radiated measurement, provided the transmitter demonstrates compliance with the peak conducted power limits. If the transmitter complies with the conducted power limits based on the use of RMS averaging over a time interval, as permitted under paragraph (b)(3) of this section, the attenuation required under this paragraph shall be 30 dB instead of 20 dB. Attenuation below the general limits specified in Section 15.209(a) is not required. In addition, radiated emissions which fall in the restricted bands, as defined in Section 15.205(a), must also comply with the radiated emission limits specified in Section 15.209(a) (see Section 15.205(c)).

### Test Results

- Refer to see the measured plot in next page.

### NOTES:

1. The test was performed to make a direct field strength measurement at the band edge frequencies.

## Plots of Bandwidth of Frequency Band Edges (GFSK)

Conducted

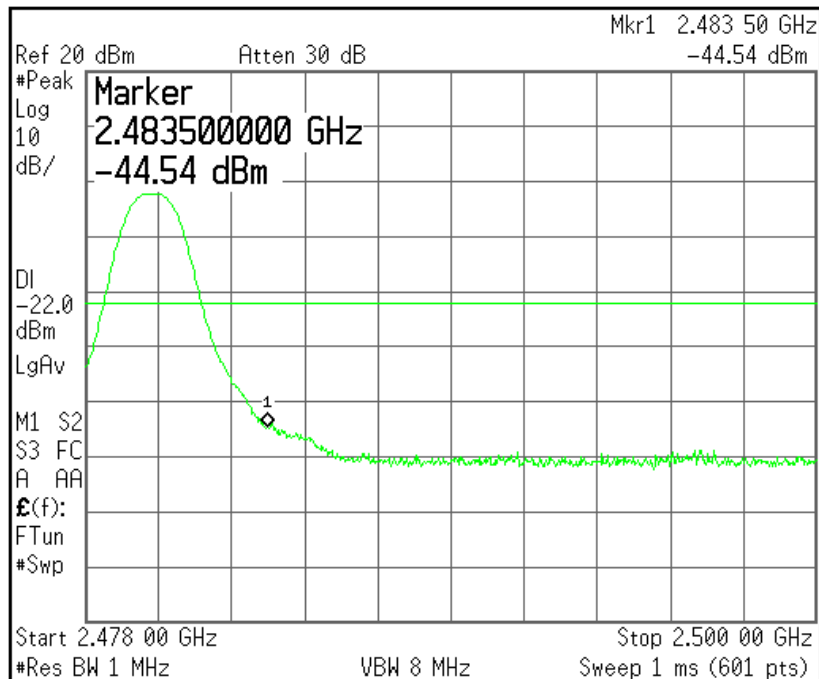
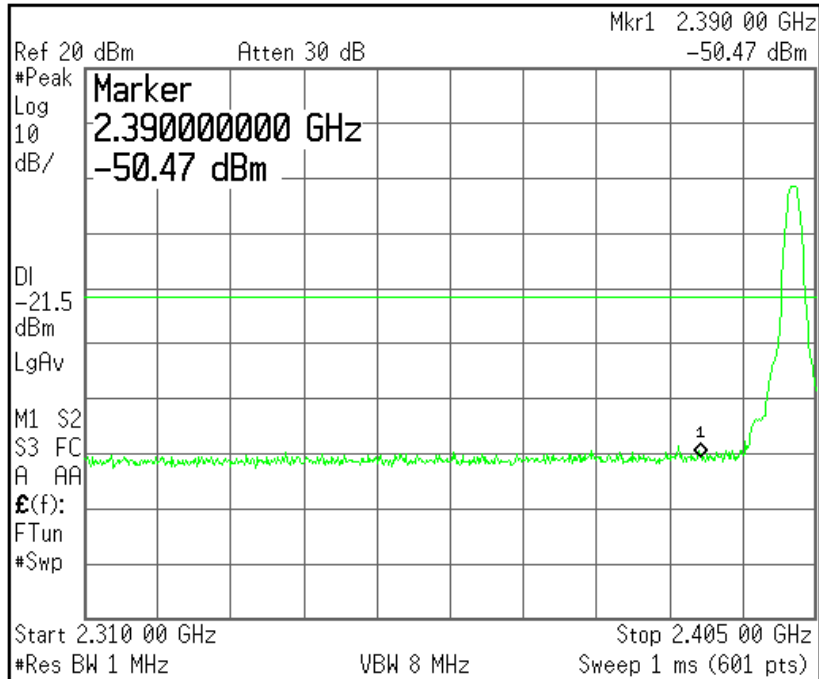

## Radiated

Peak Detector: RBW: 1 MHz, VBW: 1 MHz (2 310 MHz - 2 405 MHz), Worst case (Low, Vertical)

— Peak Limit Line  
— AV Limit Line

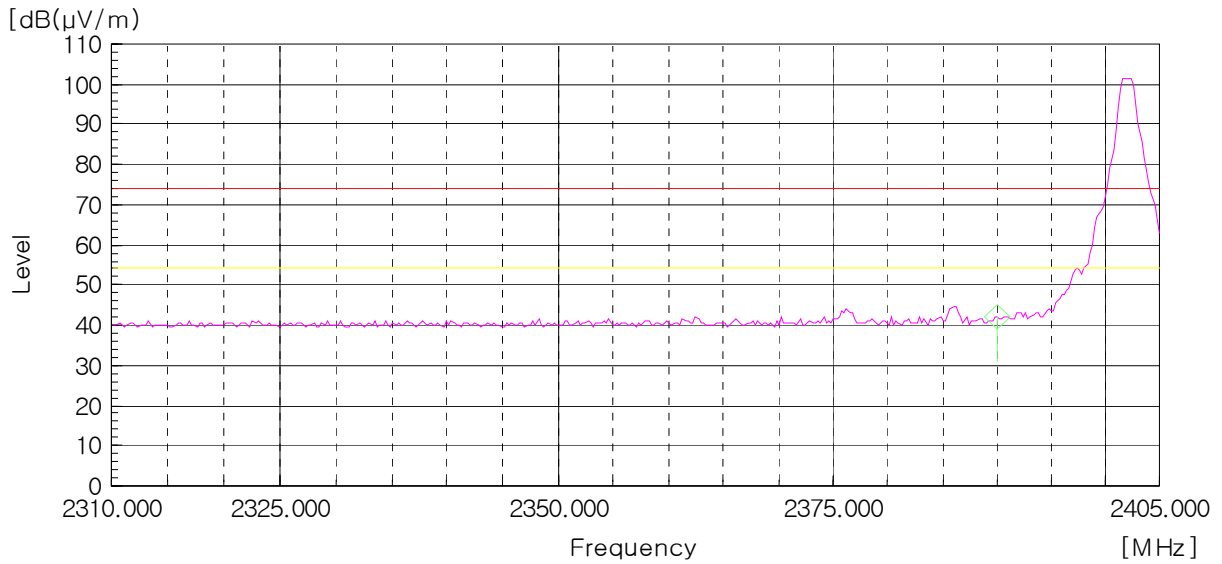

AV Detector: RBW: 1 MHz, VBW: 10 Hz (2 310 MHz - 2 405 MHz), Worst case (Low, Vertical)

— Peak Limit Line  
— AV Limit Line

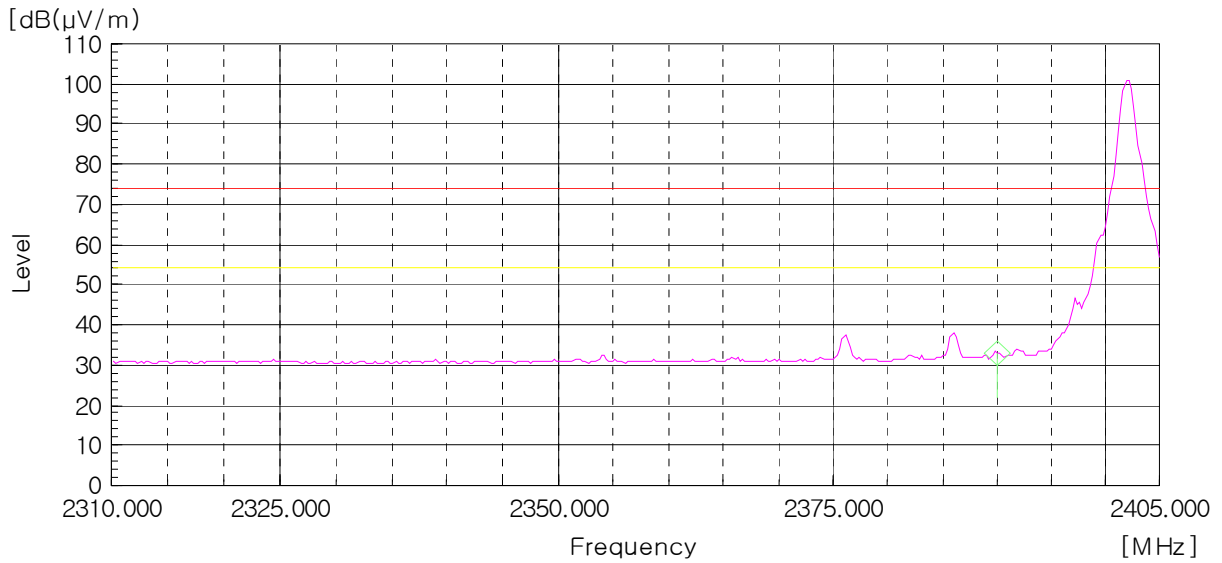

Peak Detector: RBW: 1MHz, VBW: 1 MHz (2 478.0 MHz - 2 500.0 MHz), Worst case (High, Vertical)

— Peak Limit Line  
 — AV Limit Line

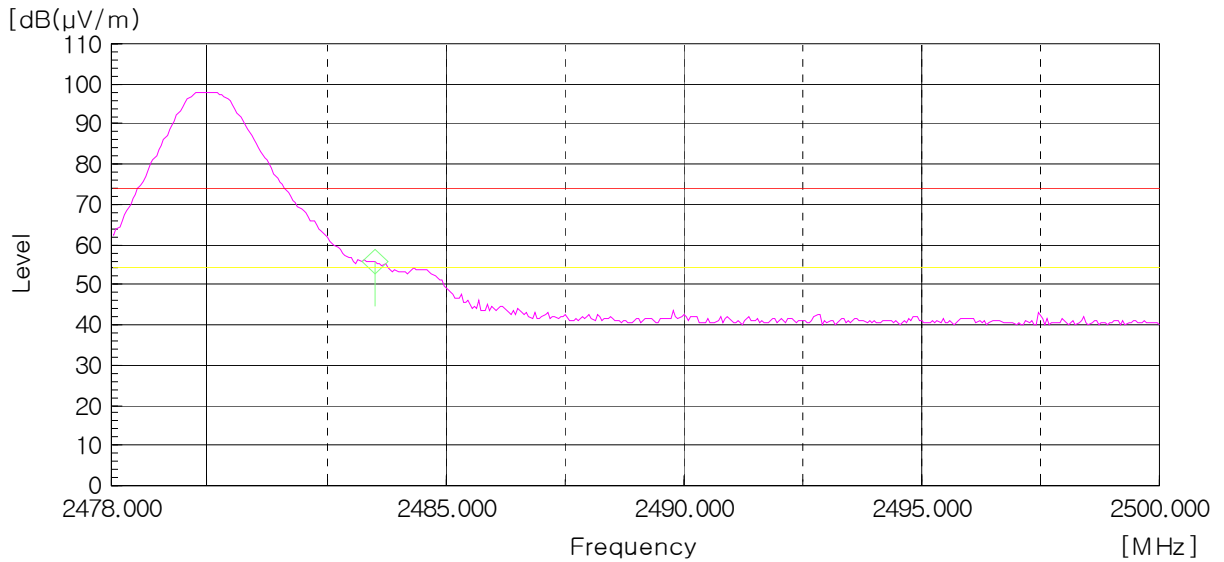

AV Detector: RBW: 1MHz, VBW: 10 Hz (2 478.0 MHz - 2 500.0 MHz), Worst case (High, Vertical)

— Peak Limit Line  
 — AV Limit Line

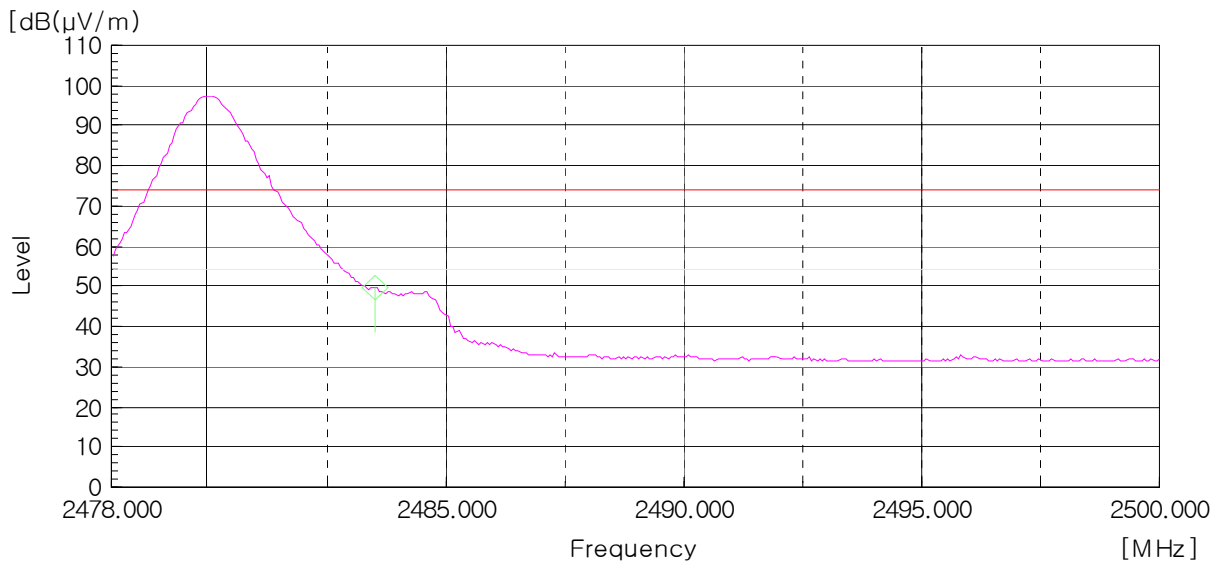



## Plots of Bandwidth of Frequency Band Edges (8DPSK)

Conducted

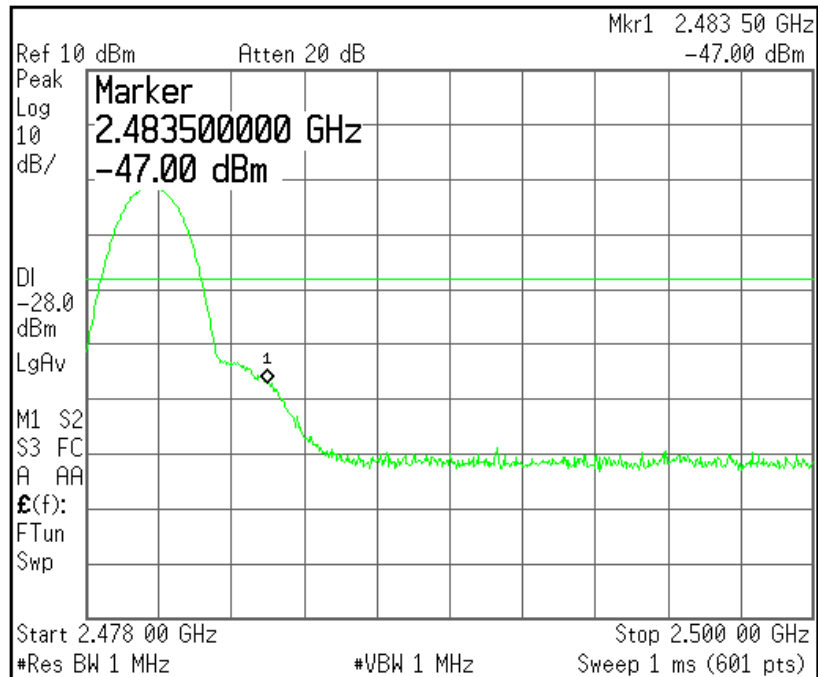
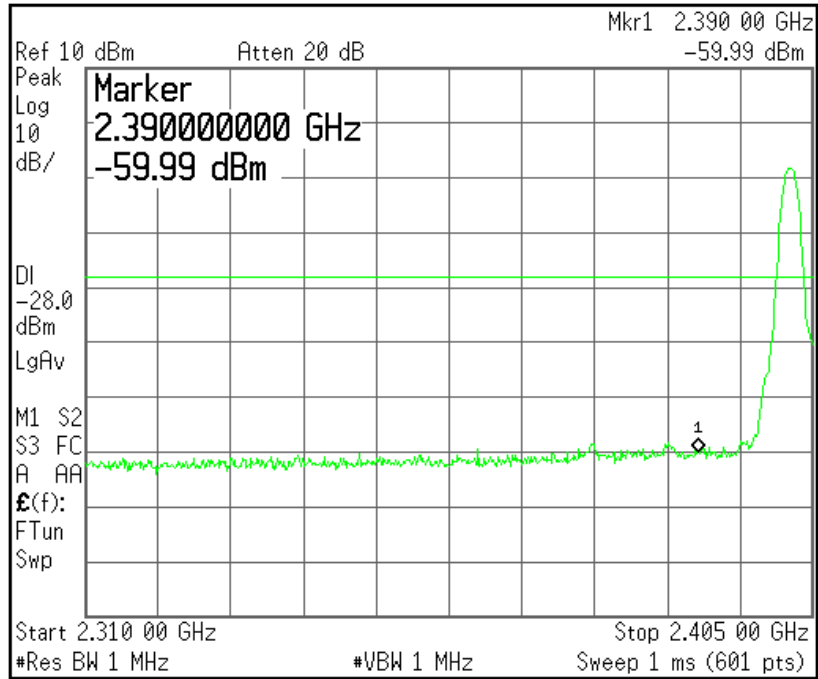

## Radiated

Peak Detector: RBW: 1 MHz, VBW: 1 MHz (2 310 MHz - 2 405 MHz), Worst case (Low, Vertical)

— Peak Limit Line  
 — AV Limit Line

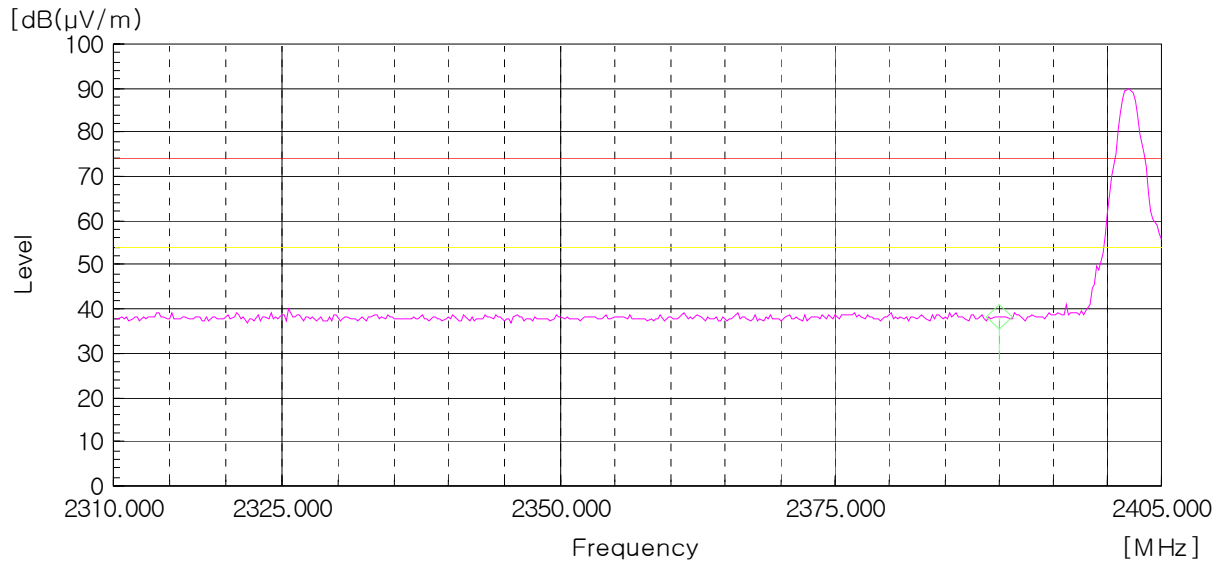

AV Detector: RBW: 1 MHz, VBW: 10 Hz (2 310 MHz - 2 405 MHz), Worst case (Low, Vertical)

— Peak Limit Line  
 — AV Limit Line

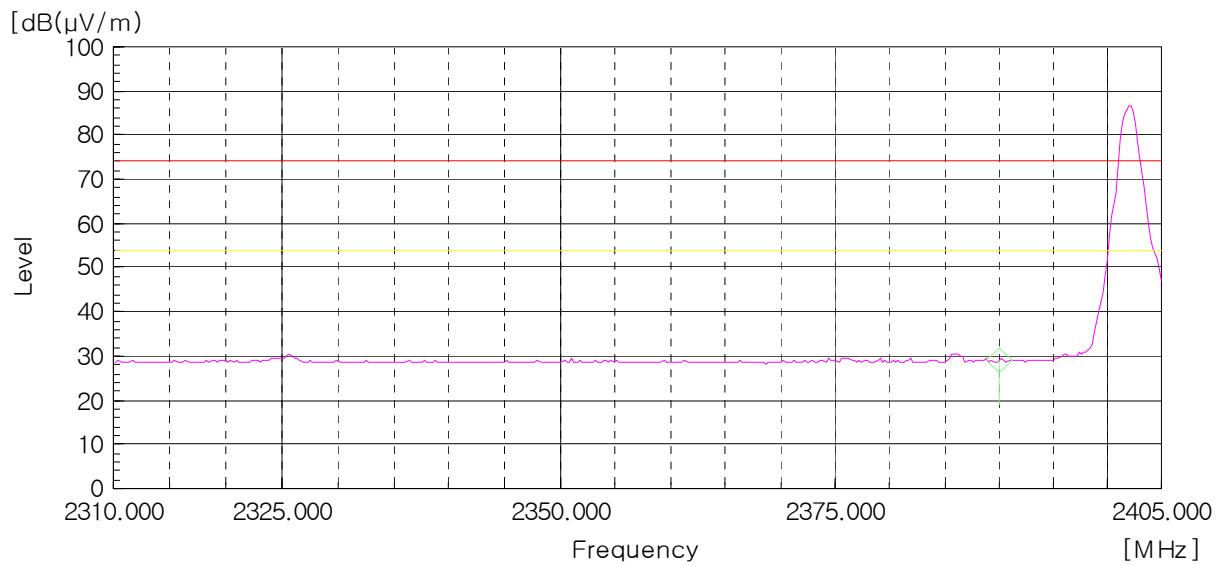

Peak Detector: RBW: 1MHz, VBW: 1 MHz (2 478.0 MHz - 2 500.0 MHz), Worst case (High, Vertical)

— Peak Limit Line  
 — AV Limit Line

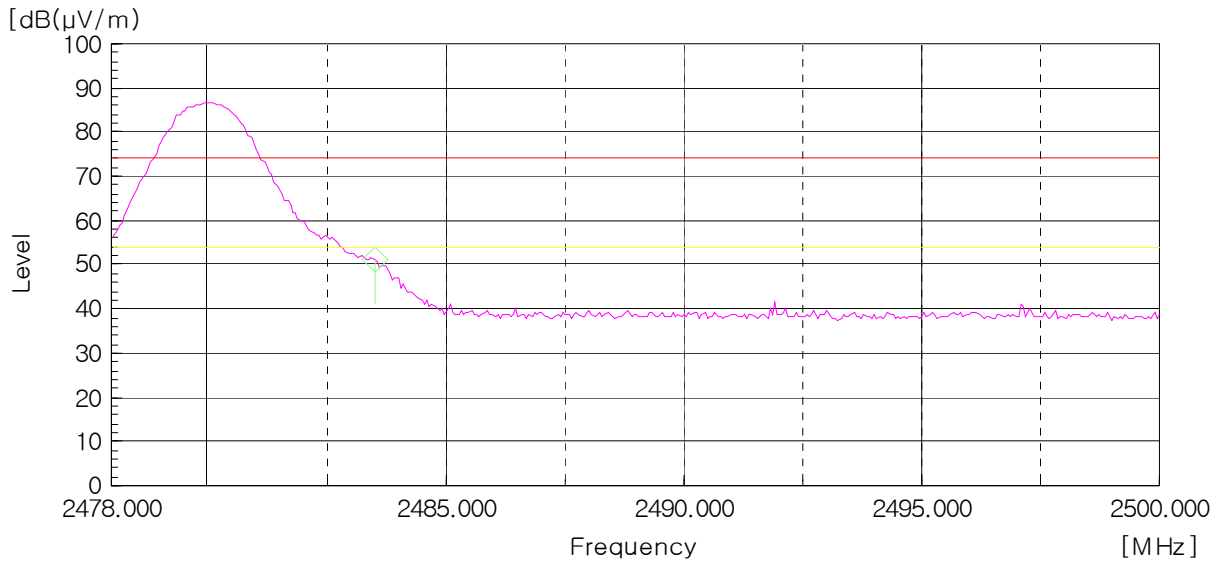

AV Detector: RBW: 1MHz, VBW: 10 Hz (2 478.0 MHz - 2 500.0 MHz), Worst case (High, Vertical)

— Peak Limit Line  
 — AV Limit Line

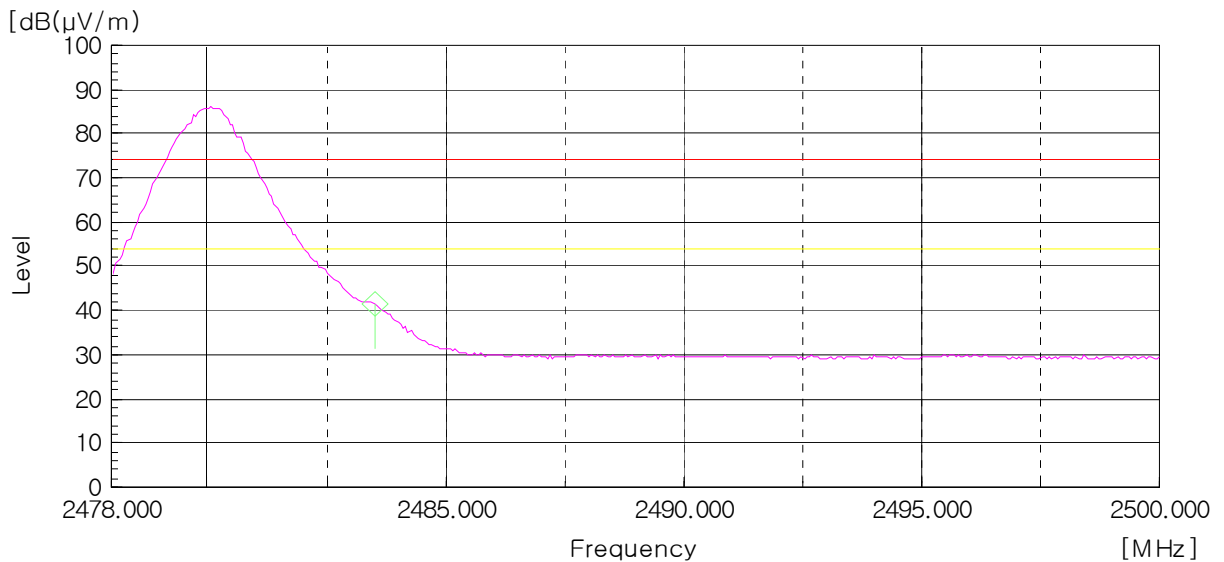

## 5.5 Number of Hopping Channels

|                     |   |
|---------------------|---|
| EUT                 | Barcode Scanner(Bluetooth/GPS) / KDC250         |
| Limit apply to      | FCC Part 15.247(a)(1)(iii)                      |
| Test Date           | June 24, 2011                                   |
| Operating Condition | RF transmitting continuously during the tested. |
| Result              | Passed  |

### Limit

Frequency hopping systems in the 2 400.0 MHz - 2 483.5 MHz band shall use at least 15 channels.

### Test Data

| Type of Modulation | Result | Limit        |
|--------------------|--------|--------------|
| GFSK               | 79     | > 15 Channel |
| 8DPSK              | 79     |              |

### NOTES:

1. Measure number of hopping channel of relevant channel using spectrum analyzer.
2. Please see the measured plot in next page.

## Plots of Number of Hopping Channels (GFSK)

[Hopping Channels]

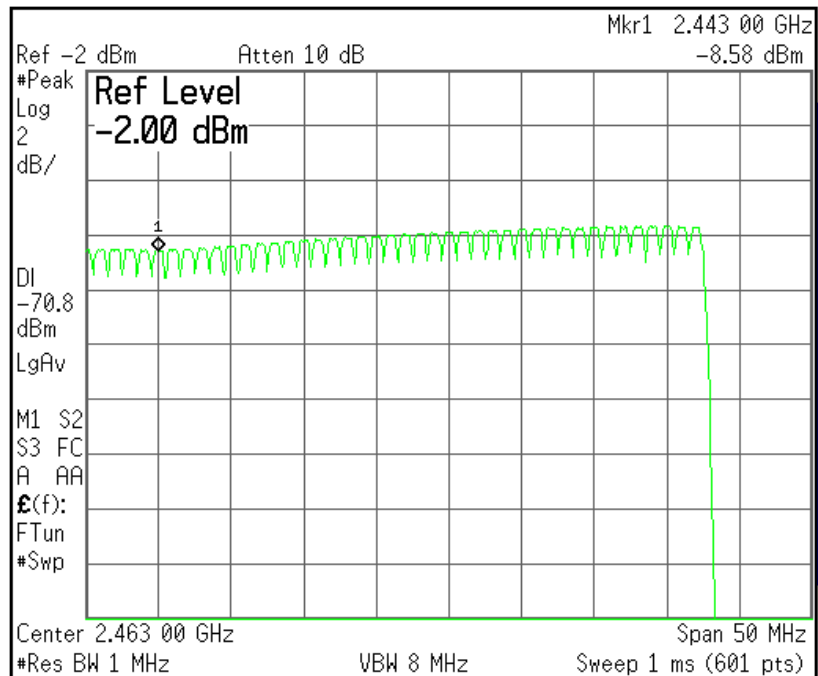
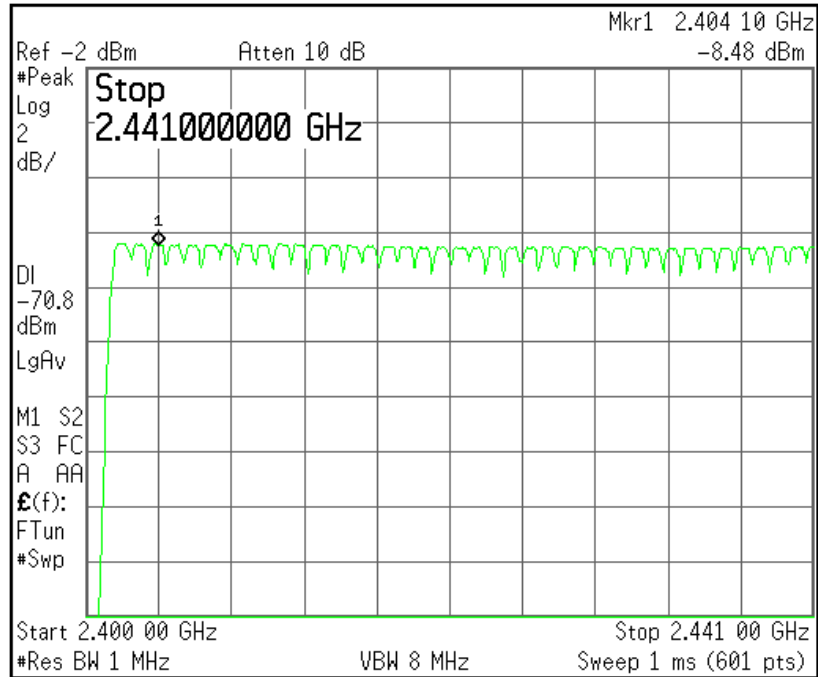

## Plots of Number of Hopping Channels (8DPSK)

[Hopping Channels]

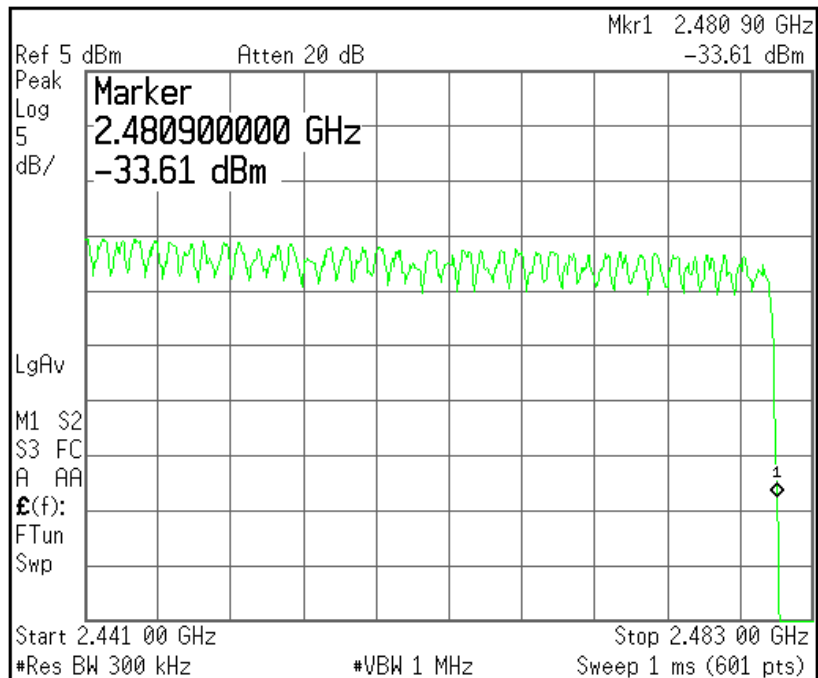
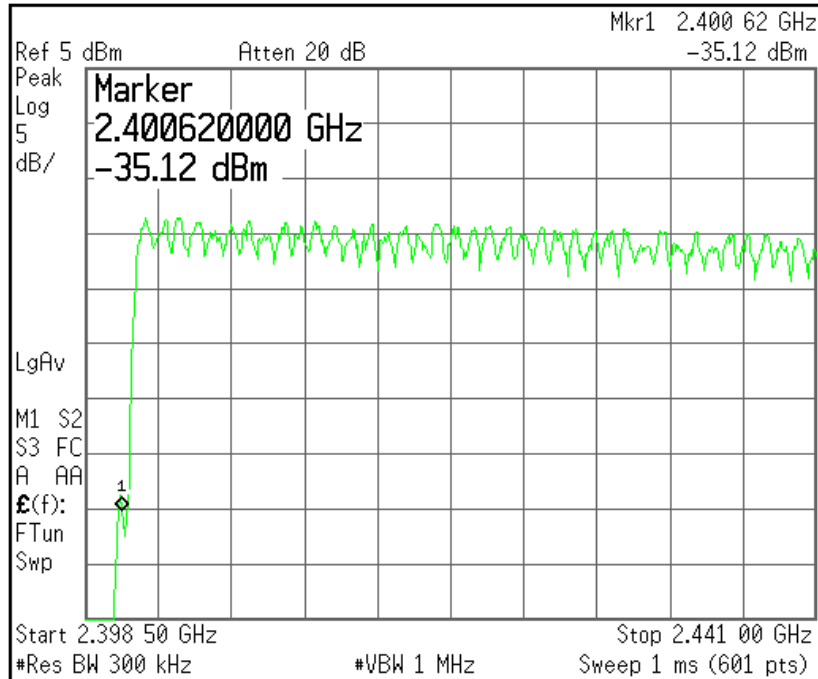

## 5.6 Time of Occupancy

|                     |   |
|---------------------|---|
| EUT                 | Barcode Scanner(Bluetooth/GPS) / KDC250         |
| Limit apply to      | FCC Part 15.247(a)(1)(iii)                      |
| Test Date           | June 24, 2011                                   |
| Operating Condition | RF transmitting continuously during the tested. |
| Result              | Passed  |

### Limit

Frequency hopping systems in the 2 400.0 MHz - 2 483.5 MHz band. The average time of occupancy on any channel shall not be greater than 0.4 seconds within a period of 0.4 seconds multiplied by the number of hopping channels employed.

### Test Data

Time of Occupancy

Test period = 0.4 [seconds/channel] x 79 [channel]

Actual = Reading x (Hopping rate/Number of channels) x Test period

Hopping rate (DH5 Packet) = 1 600 [hopping/second] / 6 [time slot] = 266.667

- GFSK

$0.4 \text{ s} \times 79 \text{ (CH)} = 31.6 \text{ s}$

$2.900 \text{ ms} \times (266.667/79) \times 31.6 \text{ s} = 309.334 \text{ ms}$

| Pulse Time [ms] | Total of Dwell [ms] | Limit [ms] |
|-----------------|---------------------|------------|
| 2.900           | 309.334             | 400.000    |

- 8DPSK

$0.4 \text{ s} \times 79 \text{ (CH)} = 31.6 \text{ s}$

$2.915 \text{ ms} \times (266.667/79) \times 31.6 \text{ s} = 310.934 \text{ ms}$

| Pulse Time [ms] | Total of Dwell [ms] | Limit [ms] |
|-----------------|---------------------|------------|
| 2.915           | 310.934             | 400.000    |

### NOTES:

1. Measure time of occupancy of relevant channel using spectrum analyzer.
2. Please see the measured plot in next page.

## Plots of Time of Occupancy (GFSK)

[Continuous Time]

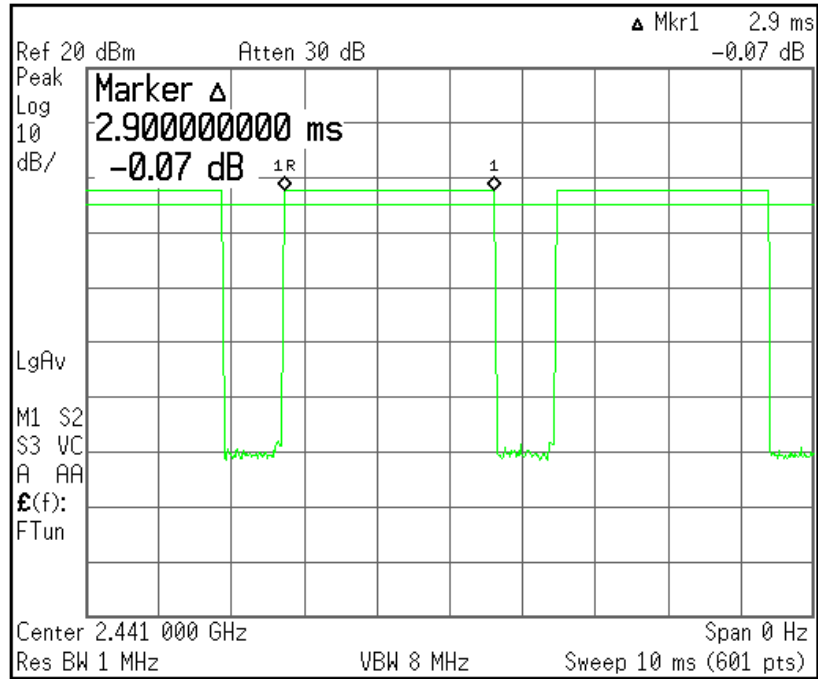

[Hopping Period]

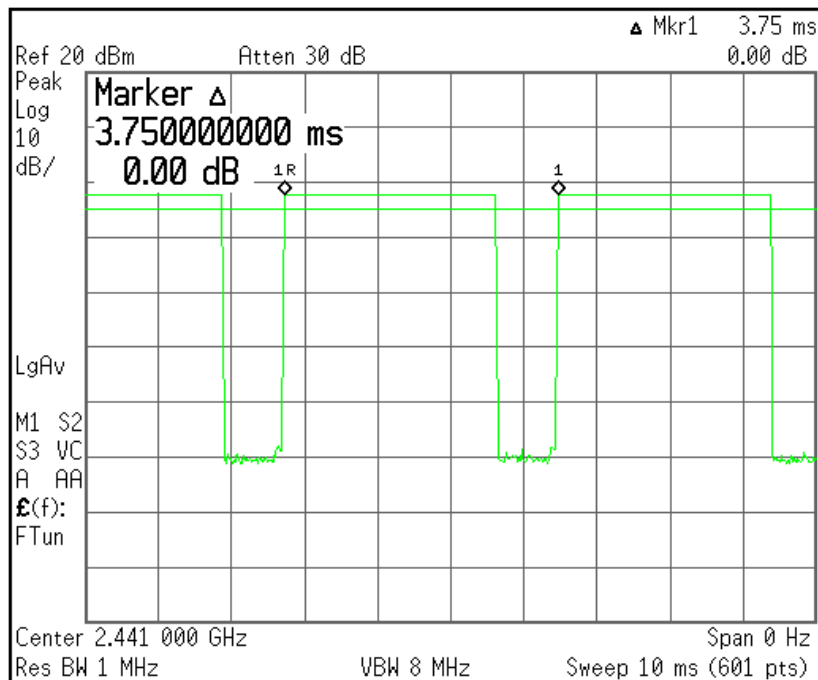



## Plots of Time of Occupancy (8DPSK)

[Continuous Time]

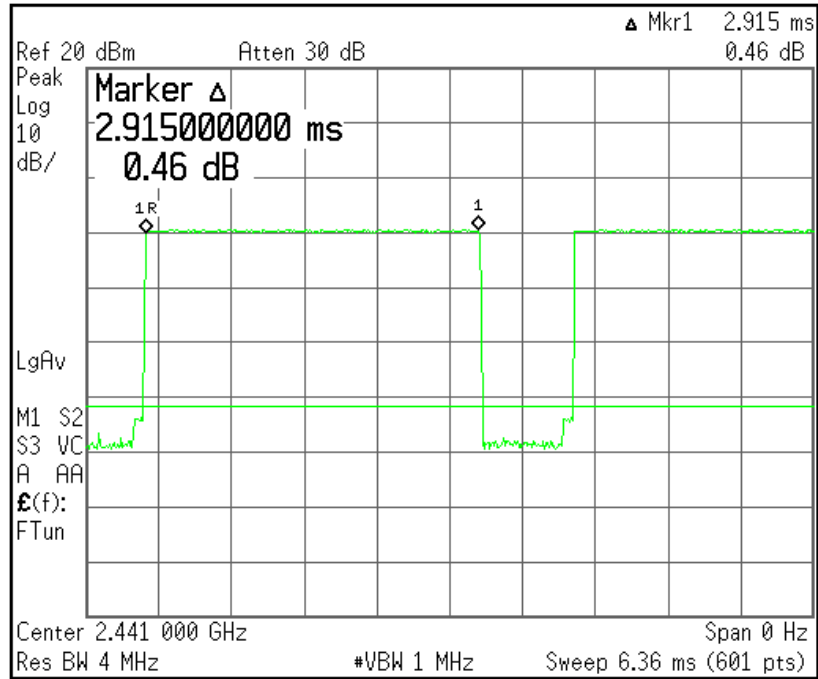

[Hopping Period]

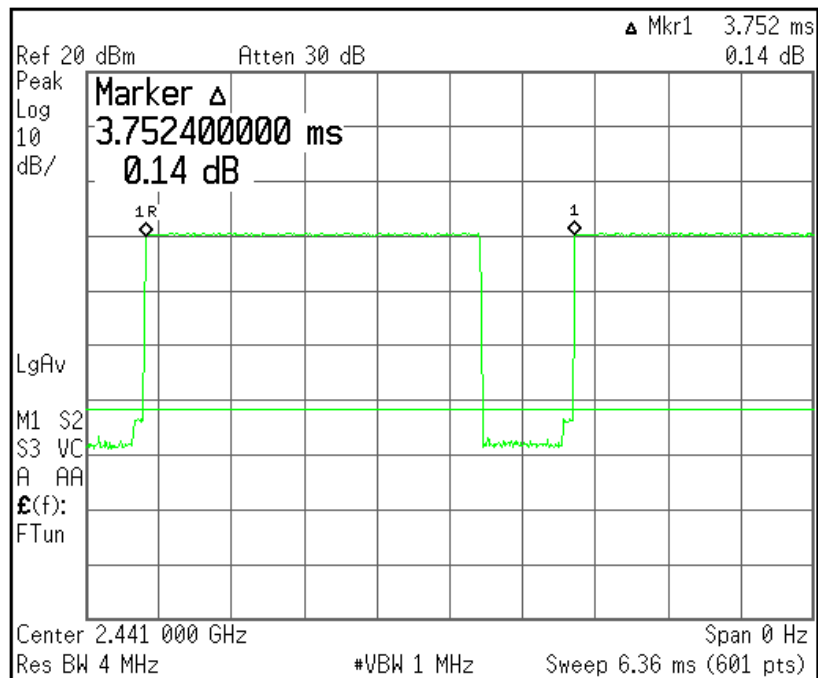

## 5.7 Spurious Emissions

|                     |   |
|---------------------|---|
| EUT                 | Barcode Scanner(Bluetooth/GPS) / KDC250 |
| Limit apply to      | FCC Part 15.209                         |
| Test Date           | June 27, 2011                           |
| Operating Condition | Low CH, Middle CH, High CH Transmission |
| Result              | Passed                                  |

### Limit

Except as provided elsewhere in this Subpart, the emissions from an intentional radiator shall not exceed the field strength levels specified in the following table:

| Frequencies [MHz] | Field Strength [ $\mu$ V/m] | Measurement Distance [m] |
|-------------------|-----------------------------|--------------------------|
| 0.009 - 0.490     | 2 400/F(kHz)                | 300                      |
| 0.490 - 1.705     | 24 000/F(kHz)               | 30                       |
| 1.705 - 30.0      | 30                          | 30                       |
| 30 - 88           | 100                         | 3                        |
| 88 - 216          | 150                         | 3                        |
| 216 - 960         | 200                         | 3                        |
| Above 960         | 500                         | 3                        |

\* Except as provided in paragraph (g), fundamental emissions from intentional radiators operating under this Section shall not be located in the frequency bands 54 MHz - 72 MHz, 76 MHz - 88 MHz, 174 MHz - 216 MHz or 470 MHz - 806 MHz. However, operation within these frequency bands is permitted under other sections of this Part, e.g., Sections 15.231 and 15.241.

### Test Results

- Refer to see the measured plot in next page.

## Radiated Emissions Test data

### - 9 kHz to 30 MHz

The following table shows the highest levels of radiated emissions on both polarizations of horizontal and vertical.  
 Detector mode: CISPR Quasi-Peak mode (100 Hz, 9 kHz)

- GFSK, 8DPSK

| Frequency [MHz] | Reading [dB(μV)]  | Polarization (*H/**V) | Ant. Factor [dB/m] | Cable Loss [dB] | Result [dB(μV/m)] | Limit [dB(μV/m)] | Margin [dB] |
|-----------------|---|-----------------------|--------------------|-----------------|-------------------|------------------|-------------|
|                 |   |                       |                    |                 |                   |                  |             |
|                 | Emission attenuated more than 20 dB below the limit are not reported. |                       |                    |                 |                   |                  |             |
|                 |   |                       |                    |                 |                   |                  |             |

**Result: All emissions below noise floor of 20 dB(μV/m).**

NOTES:

1. \* H : Horizontal polarization , \*\* V : Vertical polarization
2. Result = Reading + Antenna factor + Cable loss
3. Margin = Limit - Result
4. The measurement was performed for the frequency range 9 kHz to 30 MHz according to FCC Part 15.209.

**- Below 1 GHz (30 MHz to 1 GHz)**

The following table shows the highest levels of radiated emissions on both polarizations of horizontal and vertical. Detector mode: CISPR Quasi-Peak mode (6 dB Bandwidth: 120 kHz)

**- GFSK (Worst case)**

| Frequency [MHz] | Reading [dB(μV)] | Polarization (*H/**V) | Ant. Factor [dB/m] | Cable Loss [dB] | Result [dB(μV/m)] | Limit [dB(μV/m)] | Margin [dB] |
|-----------------|------------------|-----------------------|--------------------|-----------------|-------------------|------------------|-------------|
| 54.50           | 18.76            | V                     | 12.07              | 1.72            | 32.55             | 40.00            | 7.45        |
| 118.17          | 22.55            | V                     | 11.11              | 2.54            | 36.20             | 43.50            | 7.30        |
| 145.12          | 19.17            | V                     | 12.61              | 2.92            | 34.70             | 43.50            | 8.80        |
| 321.46          | 19.71            | H                     | 13.41              | 4.68            | 37.80             | 46.00            | 8.20        |
| 341.05          | 12.09            | H                     | 13.88              | 4.83            | 30.80             | 46.00            | 15.20       |

**NOTES:**

1. \* H : Horizontal polarization , \*\* V : Vertical polarization
2. Result = Reading + Antenna factor + Cable loss
3. Margin value = Limit - Result
4. The measurement was performed for the frequency range above 30 MHz according to FCC Part 15.209.

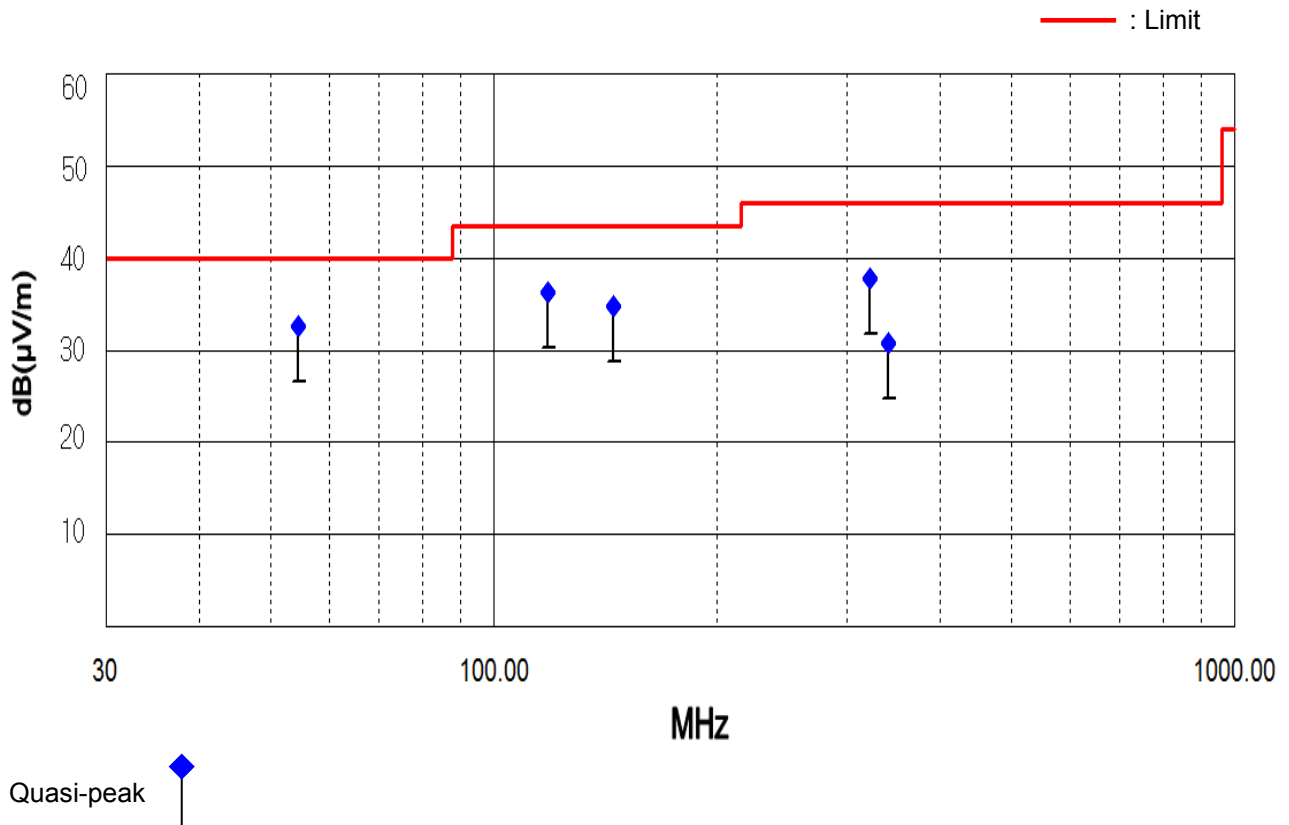

- Above 1 GHz (1 GHz to 25 GHz)

- GFSK

1. Low CH

Detector mode: Peak mode

| Frequency [MHz] | Reading [dB(μV)] | Polarization (*H/**V) | Factor [dB] | Result [dB(μV/m)] | Limit [dB(μV/m)] | Margin [dB] |
|-----------------|------------------|-----------------------|-------------|-------------------|------------------|-------------|
| 4 803.60        | 59.30            | H                     | 4.70        | 64.00             | 74.00            | 10.00       |

Detector mode: Average mode

| Frequency [MHz] | Reading [dB(μV)] | Polarization (*H/**V) | Factor [dB] | Result [dB(μV/m)] | Limit [dB(μV/m)] | Margin [dB] |
|-----------------|------------------|-----------------------|-------------|-------------------|------------------|-------------|
| 4 803.60        | 36.30            | H                     | 4.70        | 41.00             | 54.00            | 13.00       |

2. Middle CH

Detector mode: Peak mode

| Frequency [MHz] | Reading [dB(μV)] | Polarization (*H/**V) | Factor [dB] | Result [dB(μV/m)] | Limit [dB(μV/m)] | Margin [dB] |
|-----------------|------------------|-----------------------|-------------|-------------------|------------------|-------------|
| 4 881.80        | 60.10            | H                     | 4.90        | 65.00             | 74.00            | 9.00        |

Detector mode: Average mode

| Frequency [MHz] | Reading [dB(μV)] | Polarization (*H/**V) | Factor [dB] | Result [dB(μV/m)] | Limit [dB(μV/m)] | Margin [dB] |
|-----------------|------------------|-----------------------|-------------|-------------------|------------------|-------------|
| 4 881.80        | 38.10            | H                     | 4.90        | 43.00             | 54.00            | 11.00       |

3. High CH

Detector mode: Peak mode

| Frequency [MHz] | Reading [dB(μV)] | Polarization (*H/**V) | Factor [dB] | Result [dB(μV/m)] | Limit [dB(μV/m)] | Margin [dB] |
|-----------------|------------------|-----------------------|-------------|-------------------|------------------|-------------|
| 4 960.20        | 53.40            | H                     | 5.00        | 58.40             | 74.00            | 15.60       |

Detector mode: Average mode

| Frequency [MHz] | Reading [dB(μV)] | Polarization (*H/**V) | Factor [dB] | Result [dB(μV/m)] | Limit [dB(μV/m)] | Margin [dB] |
|-----------------|------------------|-----------------------|-------------|-------------------|------------------|-------------|
| 4 960.20        | 33.20            | H                     | 5.00        | 38.20             | 54.00            | 15.80       |

**Result: No signal detect above second harmonic.**

- 8DPSK

1. Low CH

Detector mode: Peak mode

| Frequency [MHz] | Reading [dB(μV)] | Polarization (*H/**V) | Factor [dB] | Result [dB(μV/m)] | Limit [dB(μV/m)] | Margin [dB] |
|-----------------|------------------|-----------------------|-------------|-------------------|------------------|-------------|
| 4 803.60        | 43.50            | H                     | 4.70        | 48.20             | 74.00            | 25.80       |

Detector mode: Average mode

| Frequency [MHz] | Reading [dB(μV)] | Polarization (*H/**V) | Factor [dB] | Result [dB(μV/m)] | Limit [dB(μV/m)] | Margin [dB] |
|-----------------|------------------|-----------------------|-------------|-------------------|------------------|-------------|
| 4 803.60        | 33.10            | H                     | 4.70        | 37.80             | 54.00            | 16.20       |

2. Middle CH

Detector mode: Peak mode

| Frequency [MHz] | Reading [dB(μV)] | Polarization (*H/**V) | Factor [dB] | Result [dB(μV/m)] | Limit [dB(μV/m)] | Margin [dB] |
|-----------------|------------------|-----------------------|-------------|-------------------|------------------|-------------|
| 4 881.90        | 43.10            | H                     | 4.90        | 48.00             | 74.00            | 26.00       |

Detector mode: Average mode

| Frequency [MHz] | Reading [dB(μV)] | Polarization (*H/**V) | Factor [dB] | Result [dB(μV/m)] | Limit [dB(μV/m)] | Margin [dB] |
|-----------------|------------------|-----------------------|-------------|-------------------|------------------|-------------|
| 4 881.90        | 32.80            | H                     | 4.90        | 37.70             | 54.00            | 16.30       |

3. High CH

Detector mode: Peak mode

| Frequency [MHz] | Reading [dB(μV)] | Polarization (*H/**V) | Factor [dB] | Result [dB(μV/m)] | Limit [dB(μV/m)] | Margin [dB] |
|-----------------|------------------|-----------------------|-------------|-------------------|------------------|-------------|
| 4 960.10        | 43.20            | H                     | 5.00        | 48.20             | 74.00            | 25.80       |

Detector mode: Average mode

| Frequency [MHz] | Reading [dB(μV)] | Polarization (*H/**V) | Factor [dB] | Result [dB(μV/m)] | Limit [dB(μV/m)] | Margin [dB] |
|-----------------|------------------|-----------------------|-------------|-------------------|------------------|-------------|
| 4 960.10        | 32.20            | H                     | 5.00        | 37.20             | 54.00            | 16.80       |

**Result: No signal detect above second harmonic.**

NOTES:

1. \* H : Horizontal polarization , \*\* V : Vertical polarization
2. Factor = Antenna factor + Cable loss + Preamp
3. Result = Reading + Factor
4. Margin = Limit - Result
5. Measuring frequencies from 1GHz to the 10<sup>th</sup> harmonic of highest fundamental frequency.
6. Measurements above show only up to 6 maximum emissions noted, or would be lesser if no specific emissions from the EUT are recorded (ie: margin > 20 dB from the applicable limit) and considered that's already beyond the background noise floor.
7. Spectrum setting:
  - a. Peak Setting 1 GHz to 10<sup>th</sup> harmonics of fundamental, RBW = 1 MHz, VBW = 1 MHz, Sweep = Auto
  - b. AV Setting 1 GHz to 10<sup>th</sup> harmonics of fundamental, RBW = 1 MHz, VBW = 10 Hz, Sweep = Auto

## Plots of Spurious Emissions (Conducted Measurement) (GFSK)

[CH Low]

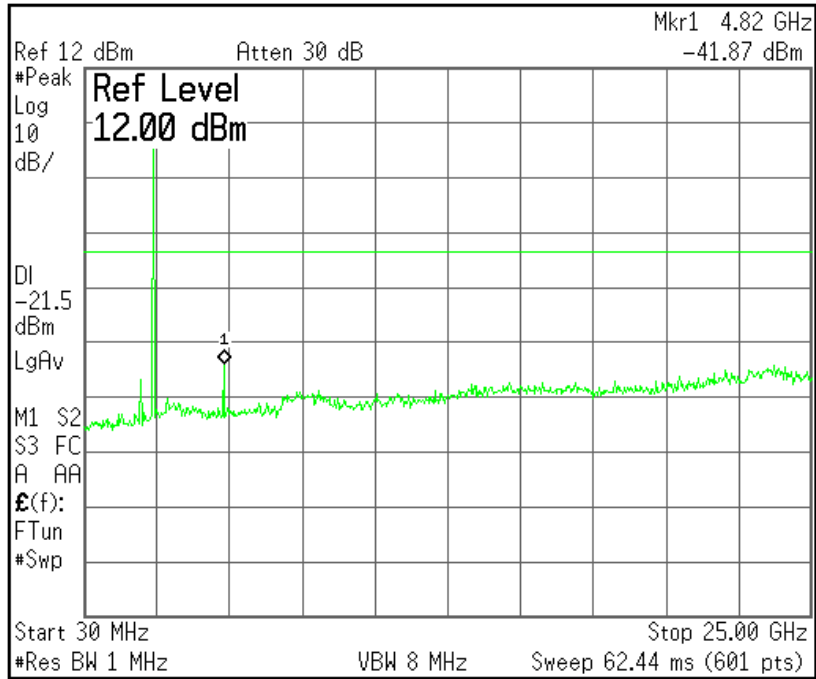

[CH Mid]

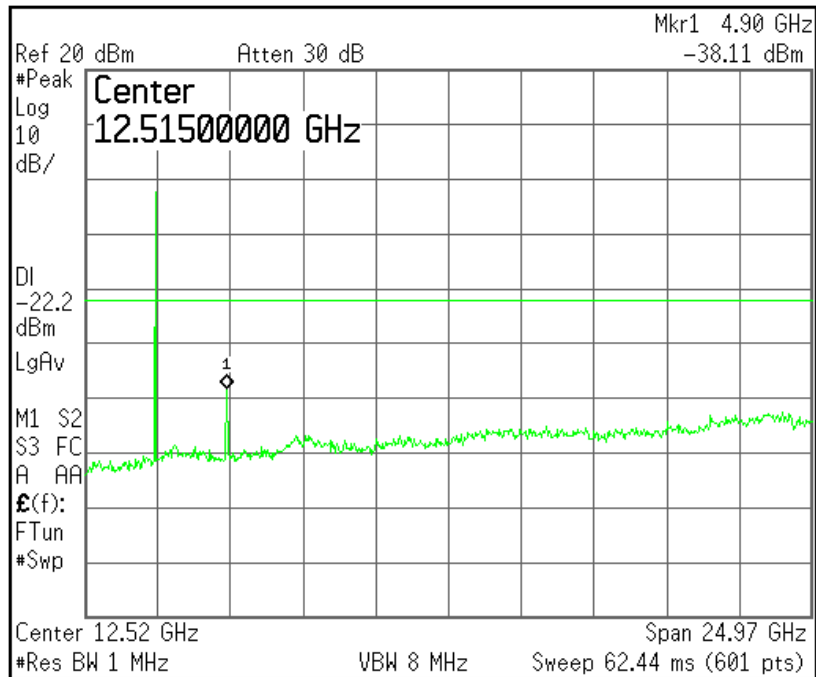



[CH High]

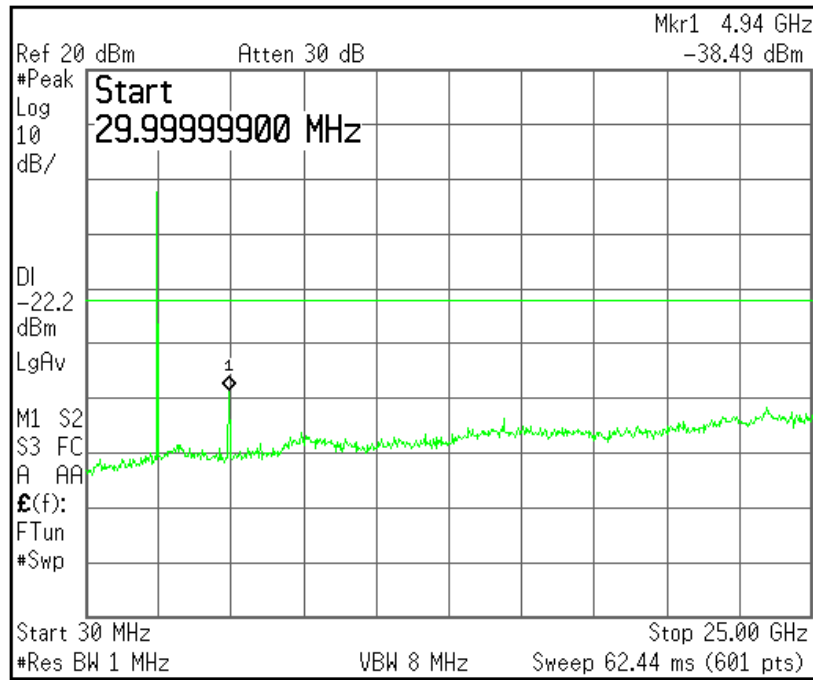

## Plots of Spurious Emissions (Conducted Measurement) (8DPSK)

[CH Low]

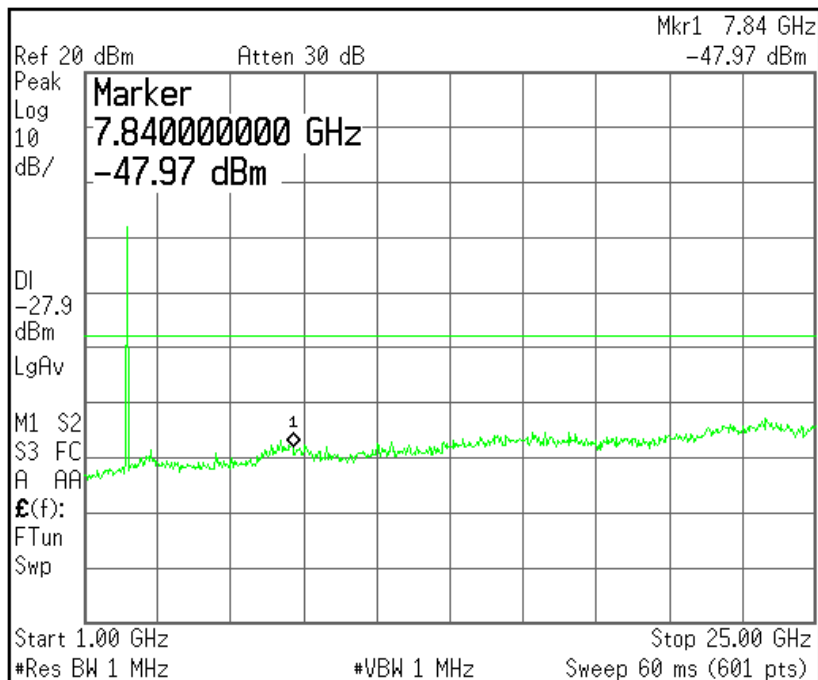

[CH Mid]

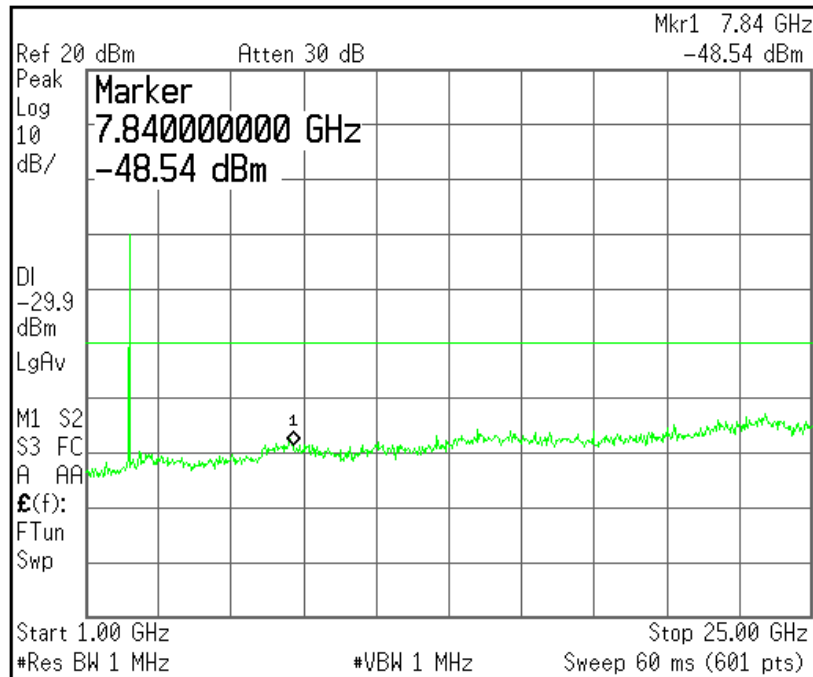

[CH High]

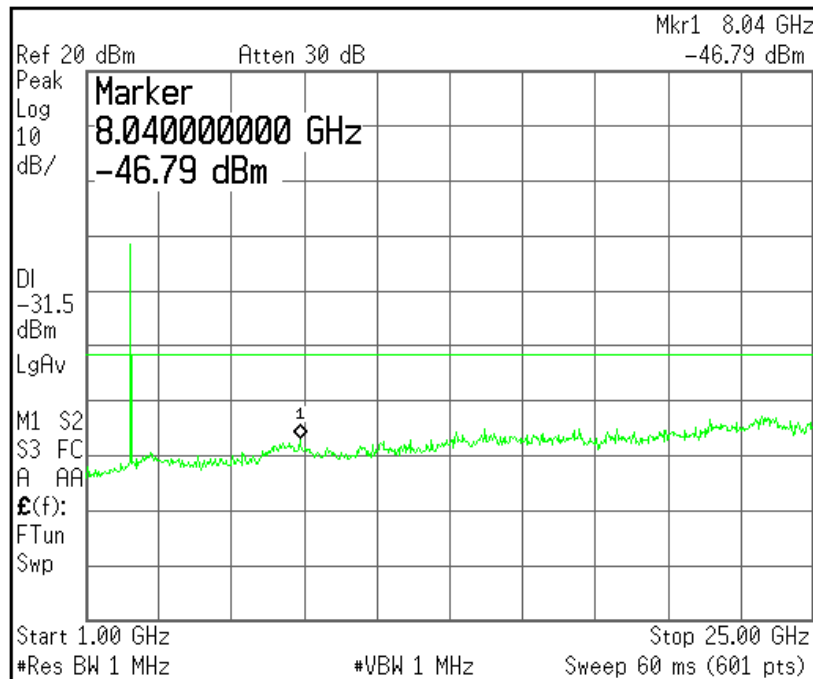

## 5.8 Conducted Emissions Measurement

|                     |   |
|---------------------|---|
| EUT                 | Barcode Scanner(Bluetooth/GPS) / KDC250         |
| Limit apply to      | FCC Part 15.207                                 |
| Test Date           | June 21, 2011                                   |
| Operating Condition | RF transmitting continuously during the tested. |
| Result              | Passed by 15.50 dB                              |

### Limit

For an intentional radiator that is designed to be connected to the public utility (AC) power line, the radio frequency voltage that is conducted back onto the AC power line on any frequency or frequencies within the band 150 kHz to 30 MHz shall not exceed the limits in the following table, as measured using a 50  $\mu$ H/50 ohms line impedance stabilization network (LISN). Compliance with the provisions of this paragraph shall be based on the measurement of the radio frequency voltage between each power line and ground at the power terminal. The lower limit applies at the boundary between the frequencies ranges.

| Frequency of Emission [MHz] | Conducted limit [dB( $\mu$ V)] |            |
|-----------------------------|--------------------------------|------------|
|                             | Quasi-peak                     | Average    |
| 0.15 - 0.5                  | 66 to 56 *                     | 56 to 46 * |
| 0.5 - 5                     | 56                             | 46         |
| 5 - 30                      | 60                             | 50         |

\* Decreases with the logarithm of the frequency.

### Test Results

- Refer to see the measured plot in next page.

## Conducted Emission Test Data

The following table shows the highest levels of conducted emissions on both polarizations of hot and neutral line.  
Detector mode: CISPR Quasi-Peak mode (6 dB Bandwidth: 9 kHz)

| Frequency [MHz] | Result [dB(μV)] |         | Phase (*L/**N) | Limit [dB(μV)] |         | Margin [dB] |         |
|-----------------|-----------------|---------|----------------|----------------|---------|-------------|---------|
|                 | Quasi-peak      | Average |                | Quasi-peak     | Average | Quasi-peak  | Average |
| 0.377           | 40.30           | -       | N              | 58.30          | 48.30   | 18.00       | -       |
| 0.500           | 38.00           | -       | N              | 56.00          | 46.00   | 18.00       | -       |
| 0.616           | 37.70           | -       | N              | 56.00          | 46.00   | 18.30       | -       |
| 0.777           | 37.60           | -       | N              | 56.00          | 46.00   | 18.40       | -       |
| 1.530           | 39.90           | -       | H              | 56.00          | 46.00   | 16.10       | -       |
| 1.843           | 40.50           | -       | H              | 56.00          | 46.00   | 15.50       | -       |
| 2.035           | 38.60           | -       | H              | 56.00          | 46.00   | 17.40       | -       |

### NOTES:

1. \* H : HOT Line , \*\*N : Neutral Line
2. The result value was included the antenna factor and cable loss.
3. Margin = Limit - Result
4. Measurement were performed at the AC Power Inlet in the frequency band of 150 kHz ~ 30 MHz according to the FCC Part 15 Class B.

**Line: HOT Line**

Limit : — Quasi-Peak  
— Average

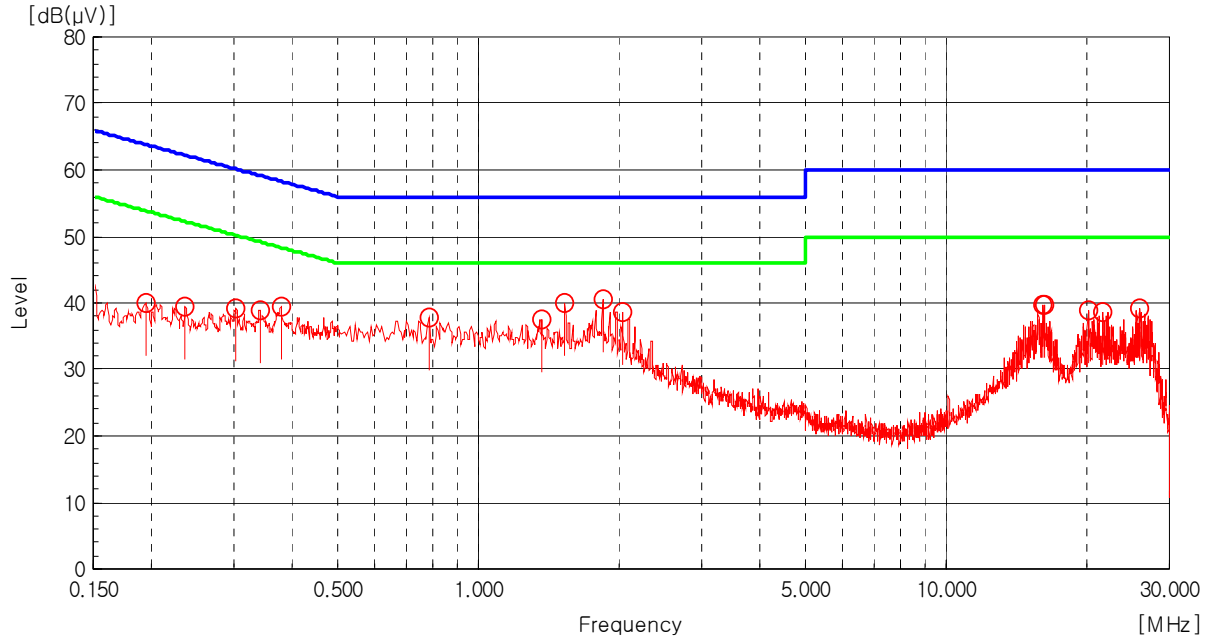

**Line: Neutral Line**

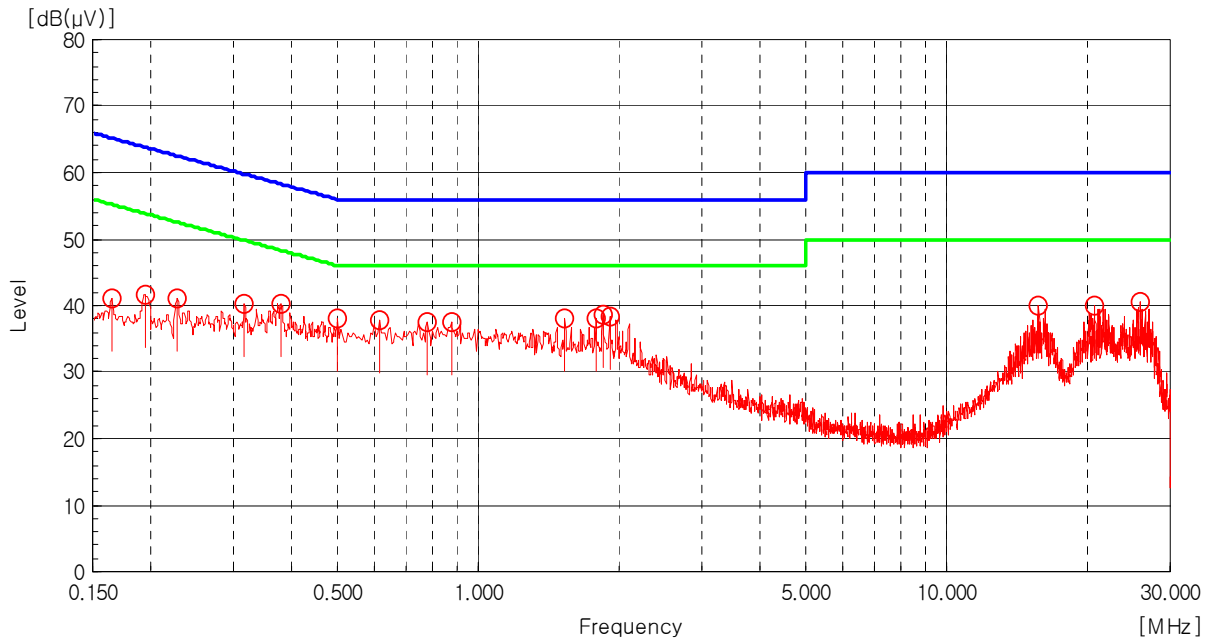

Quasi-peak 

## 5.9 Radio Frequency Exposure

According to §15.247(e)(i) and §1.1307(b)(1), systems operating under the provisions of this section shall be operated in a manner that ensures that the public is not exposed to radio frequency energy level in excess of the Commission's guidelines.

According to TCB Exclusions list, no SAR required if power is lower than the flowing threshold:

| Frequency Range     |                      | Center Frequency [MHz] | 60/f SAR Limitation [mW] |
|---------------------|----------------------|------------------------|--------------------------|
| Low Frequency [MHz] | High Frequency [MHz] |                        |                          |
| 2 402               | 2 480                | 2 441                  | 24.58                    |

Maximum measured transmitter power:

| Type of Modulation | Output Power |       | Max Antenna Gain [dBi] | EIRP [mW] |
|--------------------|--------------|-------|------------------------|-----------|
|                    | [dBm]        | [mW]  |                        |           |
| GFSK               | -1.370       | 0.729 | 2.700                  | 1.358     |
| 8DPSK              | -7.810       | 0.091 | 2.700                  | 0.308     |

## 6. SAMPLE CALCULATION

### Sample Field Strength Calculation

The field strength is calculated by adding the Antenna Factor and Cable Factor.  
The basic equation with a sample calculation is as follows:

$$FS = RA + AF + CF$$

Where FS = Field Strength

RA = Receiver Amplitude

AF = Antenna Factor

CF = Cable Attenuation Factor

$$\text{dB}(\mu\text{V}) = 20 \log_{10} (\mu\text{V}) : \text{Equation}$$

$$\text{dB}(\mu\text{V}) = \text{dBm} + 107$$

Example : @ 321.46 MHz

$$\text{Class B Limit} = 40.00 \text{ dB}(\mu\text{V}/\text{m})$$

$$\text{Reading} = 19.71 \text{ dB}(\mu\text{V})$$

$$\text{Antenna Factor} + \text{Cable Loss} = 13.41 + 4.68 = 18.09 \text{ dB}(\mu\text{V}/\text{m})$$

$$\text{Total} = 37.80 \text{ dB}(\mu\text{V}/\text{m})$$

$$\text{Margin} = 40.00 - 37.80 = 8.20 \text{ dB}$$

$$= 8.20 \text{ dB below Limit}$$

## 7. List of test equipments used for measurements

|                                     | Test Equipment                  | Model                    | Mfg.                  | Serial No. | Cal. Date | Cal. Due Date |
|-------------------------------------|---------------------------------|--------------------------|-----------------------|------------|-----------|---------------|
| <input checked="" type="checkbox"/> | EMI Test Receiver               | ESVS 10                  | R&S                   | 835165/001 | 11.03.22  | 12.03.22      |
| <input checked="" type="checkbox"/> | EMI Test Receiver               | ESPI3                    | R&S                   | 100478     | 10.09.17  | 11.09.17      |
| <input checked="" type="checkbox"/> | LISN                            | 3825/2                   | R&S                   | 9208-1995  | 10.09.16  | 11.09.16      |
| <input checked="" type="checkbox"/> | Loop Antenna                    | AL-130                   | COM-POWER             | 17100      | 11.02.10  | 13.02.10      |
| <input checked="" type="checkbox"/> | LogBicon Antenna                | VULB9160                 | Schwarzbeck           | 3082       | 10.02.22  | 12.02.22      |
| <input checked="" type="checkbox"/> | Horn Antenna                    | BBHA 9120D               | Schwarzbeck           | 227        | 11.03.22  | 13.03.22      |
| <input checked="" type="checkbox"/> | Horn Antenna                    | BBHA 9120D               | Schwarzbeck           | 9120D-826  | 10.06.11  | 12.06.11      |
| <input checked="" type="checkbox"/> | Spectrum Analyzer               | E7405A                   | H.P.                  | US41160290 | 10.09.17  | 11.09.17      |
| <input checked="" type="checkbox"/> | PSA Series Spectrum Analyzer    | E4440A                   | Agilent               | US40420382 | 11.03.23  | 12.03.23      |
| <input checked="" type="checkbox"/> | Amplifier                       | AFS42-01001800-28-10P-42 | MITEQ Inc.            | 1565819    | 11.02.14  | 12.02.14      |
| <input checked="" type="checkbox"/> | Constant Temp. & Humid. Chamber | JYT-500H                 | Jinyoung Tech         | N/A        | 11.02.14  | 12.02.14      |
| <input checked="" type="checkbox"/> | Drop Shock Tester               | JYT-D-1                  | Jinyoung Tech         | N/A        | N/A       | N/A           |
| <input checked="" type="checkbox"/> | DC Power Supply                 | DP30-05A                 | Toyo Tech             | 0300266    | 10.09.17  | 11.09.17      |
| <input checked="" type="checkbox"/> | Controller                      | HD2000                   | HD GmbH               | C/125      | N/A       | N/A           |
| <input checked="" type="checkbox"/> | Antenna Master                  | MA2400                   | HD GmbH               | N/A        | N/A       | N/A           |
| <input checked="" type="checkbox"/> | Turn-Table                      | MFT-120S                 | Max-Full Antenna Corp | -          | N/A       | N/A           |
| <input checked="" type="checkbox"/> | Antenna Master                  | MFA-440E                 | Max-Full Antenna Corp | -          | N/A       | N/A           |