

**FCC 47 CFR PART 15 SUBPART C**

**TEST REPORT**

**For**

**VigorAP 902 Dual Band 11ac AP**

**Model: VigorAP 902**

**Trade Name: DrayTek**

*Issued to*

**DrayTek Corp.**  
**No.26 Fu Shing Rd., HuKou County,Hsinchu Industrial**  
**Park,Hsinchu,Taiwan 303 R.O.C**

*Issued by*

**Compliance Certification Services Inc.**  
**No.11, Wugong 6th Rd., Wugu Dist.,**  
**New Taipei City 24891, Taiwan. (R.O.C.)**  
**<http://www.ccsrf.com>**  
**[service@ccsrf.com](mailto:service@ccsrf.com)**

**Issued Date: November 11, 2015**



---

*Note: This report shall not be reproduced except in full, without the written approval of Compliance Certification Services Inc. This document may be altered or revised by Compliance Certification Services Inc. personnel only, and shall be noted in the revision section of the document.*

**Revision History**

Rev.	Issue Date	Revisions	Effect Page	Revised By
00	November 11, 2015	Initial Issue	ALL	Kelly Cheng

## TABLE OF CONTENTS

<b>1. TEST RESULT CERTIFICATION.....</b>	<b>4</b>
<b>2. EUT DESCRIPTION.....</b>	<b>5</b>
<b>3. TEST METHODOLOGY.....</b>	<b>6</b>
3.1 EUT CONFIGURATION.....	6
3.2 EUT EXERCISE.....	6
3.3 GENERAL TEST PROCEDURES.....	6
3.4 FCC PART 15.205 RESTRICTED BANDS OF OPERATIONS.....	7
3.5 DESCRIPTION OF TEST MODES.....	8
<b>4. INSTRUMENT CALIBRATION.....</b>	<b>9</b>
4.1 MEASURING INSTRUMENT CALIBRATION.....	9
4.2 MEASUREMENT EQUIPMENT USED.....	9
4.3 MEASUREMENT UNCERTAINTY.....	10
<b>5. FACILITIES AND ACCREDITATIONS.....</b>	<b>11</b>
5.1 FACILITIES.....	11
5.2 EQUIPMENT.....	11
5.3 TABLE OF ACCREDITATIONS AND LISTINGS.....	12
<b>6. SETUP OF EQUIPMENT UNDER TEST.....</b>	<b>13</b>
6.1 SETUP CONFIGURATION OF EUT.....	13
6.2 SUPPORT EQUIPMENT.....	13
<b>7. FCC PART 15.247 REQUIREMENTS.....</b>	<b>14</b>
7.1 6DB BANDWIDTH.....	14
7.2 PEAK POWER.....	34
7.3 AVERAGE POWER.....	36
7.4 BAND EDGES MEASUREMENT.....	38
7.5 PEAK POWER SPECTRAL DENSITY.....	68
7.6 SPURIOUS EMISSIONS.....	88
7.7 RADIATED EMISSIONS.....	107
7.8 POWERLINE CONDUCTED EMISSIONS.....	123
<b>APPENDIX I PHOTOGRAPHS OF TEST SETUP.....</b>	<b>126</b>
<b>APPENDIX 1 - PHOTOGRAPHS OF EUT</b>	

# 1. TEST RESULT CERTIFICATION

**Applicant:** DrayTek Corp.  
 No.26 Fu Shing Rd., HuKou County, Hsinchu Industrial  
 Park, Hsinchu, Taiwan 303 R.O.C

**Equipment Under Test:** VigorAP 902 Dual Band 11ac AP

**Trade Name:** DrayTek

**Model Number:** VigorAP 902

**Date of Test:** March 10, 2015 ~ November 10, 2015

APPLICABLE STANDARDS	
STANDARD	TEST RESULT
FCC 47 CFR Part 15 Subpart C	No non-compliance noted

## We hereby certify that:

The above equipment was tested by Compliance Certification Services Inc. The test data, data evaluation, test procedures, and equipment configurations shown in this report were made in accordance with the procedures given in ANSI C63.10: 2013 and the energy emitted by the sample EUT tested as described in this report is in compliance with the requirements of FCC Rules Part 15.207, 15.209, 15.247.

The test results of this report relate only to the tested sample EUT identified in this report.

*Approved by:*

*Reviewed by:*





---

Miller Lee  
 Manager  
 Compliance Certification Services Inc.

---

Angel Cheng  
 Section Manager  
 Compliance Certification Services Inc.

## 2. EUT DESCRIPTION

<b>Product</b>	VigorAP 902 Dual Band 11ac AP
<b>Trade Name</b>	DrayTek
<b>Model Number</b>	VigorAP 902
<b>Model Discrepancy</b>	N/A
<b>Received Date</b>	October 01, 2015
<b>Power Adapter</b>	Vdc from Power Adapter DVE / DSA-12PFT-12 FUS 120100 I/P: 100-240Vac, 50/60Hz, 0.5A O/P: +12Vdc, 1A
<b>Frequency Range</b>	2412 ~ 2462 MHz
<b>Transmit Power</b>	IEEE 802.11b mode: 21.77 dBm IEEE 802.11g mode: 25.25 dBm IEEE 802.11n HT 20 mode: 27.49 dBm IEEE 802.11n HT 40 mode: 24.62 dBm
<b>Modulation Technique</b>	IEEE 802.11b mode: DSSS IEEE 802.11g mode: OFDM IEEE 802.11n HT 20 mode: OFDM IEEE 802.11n HT 40 mode: OFDM
<b>Number of Channels</b>	IEEE 802.11b/g mode: 11 Channels IEEE 802.11n HT 20 mode: 11 Channels IEEE 802.11n HT 40 mode: 7 Channels
<b>Antenna Specification</b>	MAG.LAYERS / EDA-1313-25GR2-A10-E Dipole Antenna / Gain: 1.81 dBi

**Remark:**

1. The sample selected for test was engineering sample that approximated to production product and was provided by manufacturer.
2. This submittal(s) (test report) is intended for FCC ID: **VGYAP902** filing to comply with Section 15.207, 15.209 and 15.247 of the FCC Part 15, Subpart C Rules.

### **3. TEST METHODOLOGY**

The tests documented in this report were performed in accordance with ANSI C63.10: 2013 and FCC CFR 47 Part 15.207, 15.209, 15.247.

#### **3.1 EUT CONFIGURATION**

The EUT configuration for testing is installed on RF field strength measurement to meet the Commissions requirement and operating in a manner that intends to maximize its emission characteristics in a continuous normal application.

#### **3.2 EUT EXERCISE**

The EUT was operated in the engineering mode to fix the TX frequency that was for the purpose of the measurements.

According to its specifications, the EUT must comply with the requirements of the Section 15.207, 15.209 and 15.247 under the FCC Rules Part 15 Subpart C.

#### **3.3 GENERAL TEST PROCEDURES**

##### **Conducted Emissions**

The EUT is placed on the turntable, which is 0.8 m above ground plane. According to the requirements in Section 13.1.4.1 of ANSI C63.10 Conducted emissions from the EUT measured in the frequency range between 0.15 MHz and 30MHz using CISPR Quasi-peak and average detector modes.

##### **Radiated Emissions**

The EUT is placed on a turn table, which is 1.5 m above ground plane. The turntable shall rotate 360 degrees to determine the position of maximum emission level. EUT is set 3m away from the receiving antenna, which varied from 1m to 4m to find out the highest emission. And also, each emission was to be maximized by changing the polarization of receiving antenna both horizontal and vertical. In order to find out the maximum emissions, exploratory radiated emission measurements were made according to the requirements in Section 13.1.4.1 of ANSI C63.10.

### 3.4 FCC PART 15.205 RESTRICTED BANDS OF OPERATIONS

(a) Except as shown in paragraph (d) of this section, only spurious emissions are permitted in any of the frequency bands listed below:

MHz	MHz	MHz	GHz
0.090 - 0.110	16.42 - 16.423	399.9 - 410	4.5 - 5.15
<sup>1</sup> 0.495 - 0.505	16.69475 - 16.69525	608 - 614	5.35 - 5.46
2.1735 - 2.1905	16.80425 - 16.80475	960 - 1240	7.25 - 7.75
4.125 - 4.128	25.5 - 25.67	1300 - 1427	8.025 - 8.5
4.17725 - 4.17775	37.5 - 38.25	1435 - 1626.5	9.0 - 9.2
4.20725 - 4.20775	73 - 74.6	1645.5 - 1646.5	9.3 - 9.5
6.215 - 6.218	74.8 - 75.2	1660 - 1710	10.6 - 12.7
6.26775 - 6.26825	108 - 121.94	1718.8 - 1722.2	13.25 - 13.4
6.31175 - 6.31225	123 - 138	2200 - 2300	14.47 - 14.5
8.291 - 8.294	149.9 - 150.05	2310 - 2390	15.35 - 16.2
8.362 - 8.366	156.52475 -	2483.5 - 2500	17.7 - 21.4
8.37625 - 8.38675	156.52525	2655 - 2900	22.01 - 23.12
8.41425 - 8.41475	156.7 - 156.9	3260 - 3267	23.6 - 24.0
12.29 - 12.293	162.0125 - 167.17	3332 - 3339	31.2 - 31.8
12.51975 - 12.52025	167.72 - 173.2	3345.8 - 3358	36.43 - 36.5
12.57675 - 12.57725	240 - 285	3600 - 4400	( <sup>2</sup> )
13.36 - 13.41	322 - 335.4		

<sup>1</sup> Until February 1, 1999, this restricted band shall be 0.490-0.510 MHz.

<sup>2</sup> Above 38.6

(b) Except as provided in paragraphs (d) and (e), the field strength of emissions appearing within these frequency bands shall not exceed the limits shown in Section 15.209. At frequencies equal to or less than 1000 MHz, compliance with the limits in Section 15.209 shall be demonstrated using measurement instrumentation employing a CISPR quasi-peak detector. Above 1000 MHz, compliance with the emission limits in Section 15.209 shall be demonstrated based on the average value of the measured emissions. The provisions in Section 15.35 apply to these measurements.

### **3.5 DESCRIPTION OF TEST MODES**

The EUT (Model: VigorAP 902) was found to emit the worst emissions and therefore had been tested under operating condition.

The EUT is a 2x2 configuration spatial MIMO (2Tx & 2Rx) without beam forming function that operate in double TX chains and double RX chains. The 2x2 configuration is implemented with two outside TX & RX chains (Chain 0 and 1).

Software used to control the EUT for staying in continuous transmitting mode was programmed.

After verification, all tests were carried out with the worst case test modes as shown below except radiated spurious emission below 1GHz and power line conducted emissions below 30MHz, which worst case was in normal link mode only.

**IEEE 802.11b mode:**

Channel Low (2412MHz), Channel Mid (2437MHz) and Channel High (2462MHz) with 1Mbps data rate and cyclic delay diversity were chosen for full testing.

**IEEE 802.11g mode:**

Channel Low (2412MHz), Channel Mid (2437MHz) and Channel High (2462MHz) with 6Mbps data rate and cyclic delay diversity were chosen for full testing.

**IEEE 802.11n HT 20 mode:**

Channel Low (2412MHz), Channel Mid (2437MHz) and Channel High (2462MHz) with 6.5Mbps data rate were chosen for full testing.

**IEEE 802.11n HT 40 mode:**

Channel Low (2422MHz), Channel Mid (2437MHz) and Channel High (2452MHz) with 13.5Mbps data rate were chosen for full testing.

The field strength of spurious emission was measured in the following position: EUT stand-up position (Z axis), lie-down position (X, Y axis). The worst emission was found in lie-down position (X axis) and the worst case was recorded.



## 4. INSTRUMENT CALIBRATION

### 4.1 MEASURING INSTRUMENT CALIBRATION

The measuring equipment, which was utilized in performing the tests documented herein, has been calibrated in accordance with the manufacturer's recommendations for utilizing calibration equipment, which is traceable to recognized national standards.

### 4.2 MEASUREMENT EQUIPMENT USED

#### Equipment Used for Emissions Measurement

Conducted Emissions Test Site				
Name of Equipment	Manufacturer	Model	Serial Number	Calibration Due
Spectrum Analyzer	Agilent	E4446A	US42510252	11/23/2015
Thermostatic/Hrgrosatic Chamber	TAICHY	MHG-150LF	930619	10/06/2016
AC Power Source	EXTECH	6205	1140845	N.C.R
DC Power Supply	ABM	8301HD	D011531	N.C.R
Power Meter	Anritsu	ML2495A	1012009	06/07/2016
Power Sensor	Anritsu	MA2411A	0917072	06/08/2016
Spectrum Analyzer	ROHDE&SCHWARZ	FSV40	101073	07/08/2016

Conducted Emission Room #B				
Name of Equipment	Manufacturer	Model	Serial Number	Calibration Due
EMI Test Receiver	R&S	ESCI	101073	09/08/2016
LISN	R&S	ENV216	101054	06/06/2016
LISN	SCHWARZBECK	NSLK 8127	8127-541	11/25/2015
Capacitive Voltage Probe	FCC	F-CVP-1	100185	03/12/2016
Test S/W	CCS-3A1-CE			

Wugu 966 Chamber A				
Name of Equipment	Manufacturer	Model	Serial Number	Calibration Due
Spectrum Analyzer	Agilent	E4446A	US42510268	01/25/2016
EMI Test Receiver	R&S	ESCI	100064	06/03/2016
Bilog Antenna	Sunol Sciences	JB3	A030105	08/05/2016
Horn Antenna	EMCO	3117	00055165	01/26/2016
Horn Antenna	EMCO	3116	26370	12/25/2015
Turn Table	CCS	CC-T-1F	N/A	N.C.R
Antenna Tower	CCS	CC-A-1F	N/A	N.C.R
Controller	CCS	CC-C-1F	N/A	N.C.R
Pre-Amplifier	MITEQ	1652-3000	1490939	08/09/2016
Pre-Amplifier	EMC	EMC 012635	980151	06/04/2016
Pre-Amplifier	MITEQ	AMF-6F-260400-40-8P	985646	12/25/2015
Coaxial Cable	Huber+Suhner	102	29212/2	12/25/2015
Coaxial Cable	Huber+Suhner	102	29406/2	12/25/2015
Test S/W	EZ-EMC (CCS-3A1RE)			

**NOTE:** 1. The calibration interval of the above test instruments is 12 months and the calibrations are traceable to NML/ROC and NIST/USA.  
 2. N.C.R = No Calibration Request.

### 4.3 MEASUREMENT UNCERTAINTY

PARAMETER	UNCERTAINTY
Powerline Conducted Emission	+/- 1.2159
3M Semi Anechoic Chamber / <200M	+/- 4.0138
3M Semi Anechoic Chamber / 200M~1000M	+/- 3.9483
3M Semi Anechoic Chamber / 1G~8G	+/- 2.5975
3M Semi Anechoic Chamber / 8G~18G	+/- 2.6112
3M Semi Anechoic Chamber / 18G~26G	+/- 2.7389
3M Semi Anechoic Chamber / 26G~40G	+/- 2.9683

**Remark:** This uncertainty represents an expanded uncertainty expressed at approximately the 95% confidence level using a coverage factor of  $k=2$ .

## **5. FACILITIES AND ACCREDITATIONS**

### **5.1 FACILITIES**

All measurement facilities used to collect the measurement data are located at

- No.199, Chunghsen Road, Hsintien City, Taipei Hsien, Taiwan, R.O.C.
- No.139, Wugong Rd., Wugu Dist., New Taipei City 24891, Taiwan (R.O.C.)
- No.11, Wugong 6th Rd., Wugu Dist., New Taipei City 24891, Taiwan. (R.O.C.)
- No.81-1, Lane 210, Bade 2nd Rd., Lujhu Township, Taoyuan County 33841, TAIWAN, R.O.C.

The sites are constructed in conformance with the requirements of ANSI C63.7, ANSI C63.10 and CISPR Publication 22.

### **5.2 EQUIPMENT**



Radiated emissions are measured with one or more of the following types of linearly polarized antennas: tuned dipole, biconical, log periodic, bi-log, and/or ridged waveguide, horn. Spectrum analyzers with pre-selectors and quasi-peak detectors are used to perform radiated measurements.

Conducted emissions are measured with Line Impedance Stabilization Networks and EMI Test Receivers.

Calibrated wideband preamplifiers, coaxial cables, and coaxial attenuators are also used for making measurements.

All receiving equipment conforms to CISPR Publication 16-1, "Radio Interference Measuring Apparatus and Measurement Methods."

### 5.3 TABLE OF ACCREDITATIONS AND LISTINGS

Country	Agency	Scope of Accreditation	Logo
USA	FCC	3M Semi Anechoic Chamber (FCC MRA: TW1039) to perform FCC Part 15 measurements	 FCC MRA: TW1039
Taiwan	TAF	LP0002, RTTE01, FCC Method-47 CFR Part 15 Subpart C, D, E, RSS-310 IDA TS SRD, AS/NZS 4268, AS/NZS 4771, TS 12.1 & 12.2, ETSI EN 300 440-1, ETSI EN 300 440-2, ETSI EN 300 328, ETSI EN 300 220-1, ETSI EN 300 220-2, ETSI EN 301 893, ETSI EN 301 489-1/3/7/17 FCC OET Bulletin 65 + Supplement C, EN 50360, EN 50361, EN 50371, RSS 102, EN 50383, EN 50385, EN 50392, IEC 62209, CNS 14958-1, CNS 14959 FCC Method -47 CFR Part 15 Subpart B IEC / EN 61000-3-2, IEC / EN 61000-3-3, IEC / EN 61000-4-2/3/4/5/6/8/11	
Canada	Industry Canada	3M Semi Anechoic Chamber (IC 2324G-1 / IC 2324G-2) to perform	 IC 2324G-1 IC 2324G-2

\* No part of this report may be used to claim or imply product endorsement by A2LA or any agency of the US Government.

## 6. SETUP OF EQUIPMENT UNDER TEST

### 6.1 SETUP CONFIGURATION OF EUT

See test photographs attached in Appendix II for the actual connections between EUT and support equipment.

### 6.2 SUPPORT EQUIPMENT

No	Equipment	Brand	Model	Series No.	FCC ID	Data Cable	Power Cord
1	Printer	EPSON	Stylus-C63	FAPY150360	R33126	N/A	Non-shielded, 1.8m
2	Notebook PC (Remote)	HP	Pavilion dv6	CNF9491GLJ	R33022	N/A	Non-shielded, 2.0m
3	Notebook PC (Remote)	HP	Pavilion dv6	VX250PA#ABO	R33022	N/A	Non-shielded, 2.0m
4	Terminal (Remote)	N/A	N/A	N/A	N/A	N/A	N/A
5	WIFI Dongle	EDIMAX	AC600	N/A	N/A	N/A	N/A

**Remark:**

- All the equipment/cables were placed in the worst-case configuration to maximize the emission during the test.*
- Grounding was established in accordance with the manufacturer's requirements and conditions for the intended use.*

## 7. FCC PART 15.247 REQUIREMENTS

### 7.1 6DB BANDWIDTH

#### LIMIT

According to §15.247(a)(2), systems using digital modulation techniques may operate in the 902 - 928 MHz, 2400 - 2483.5 MHz, and 5725 - 5850 MHz bands. The minimum 6dB bandwidth shall be at least 500 kHz.

#### Test Configuration

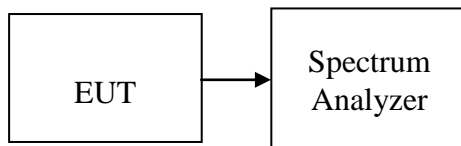

#### TEST PROCEDURE

The transmitter output is connected to the spectrum analyzer. Set the RBW=100kHz the emission bandwidth, VBW  $\geq 3 \times$  RBW, Detector = Peak, Trace mode = max hold, Sweep = auto couple. Measure the maximum width of the emission that is constrained by the frequencies associated with the two amplitude points (upper and lower) that are attenuated by 6dB relative to the maximum level measured in the fundamental emission.

#### TEST RESULTS

*No non-compliance noted.*

**Test Data**

**Test mode: IEEE 802.11b mode**

Channel	Frequency (MHz)	Bandwidth (MHz)	Limit (kHz)	Result
Low	2412	10.3334	>500	PASS
Mid	2437	10.3334		PASS
High	2462	10.3334		PASS

**Test mode: IEEE 802.11g mode**

Channel	Frequency (MHz)	Bandwidth (MHz)	Limit (kHz)	Result
Low	2412	16.9166	>500	PASS
Mid	2437	16.6666		PASS
High	2462	16.75		PASS

**Test mode: IEEE 802.11n HT 20 mode / Chain 0**

Channel	Frequency (MHz)	Bandwidth (MHz)	Limit (kHz)	Result
Low	2412	17.8334	>500	PASS
Mid	2437	17.8334		PASS
High	2462	17.8334		PASS

**Test mode: IEEE 802.11n HT 20 mode / Chain 1**

Channel	Frequency (MHz)	Bandwidth (MHz)	Limit (kHz)	Result
Low	2412	17.8334	>500	PASS
Mid	2437	17.8334		PASS
High	2462	17.8334		PASS

**Test mode: IEEE 802.11n HT 40 mode / Chain 0**

Channel	Frequency (MHz)	Bandwidth (MHz)	Limit (kHz)	Result
Low	2422	36.8333	>500	PASS
Mid	2437	36.9166		PASS
High	2452	36.9166		PASS

**Test mode: IEEE 802.11n HT 40 mode / Chain 1**

Channel	Frequency (MHz)	Bandwidth (MHz)	Limit (kHz)	Result
Low	2422	36.5833	>500	PASS
Mid	2437	36.5833		PASS
High	2452	36.5		PASS

**Test Plot**

**IEEE 802.11b mode**

**6dB Bandwidth (CH Low)**

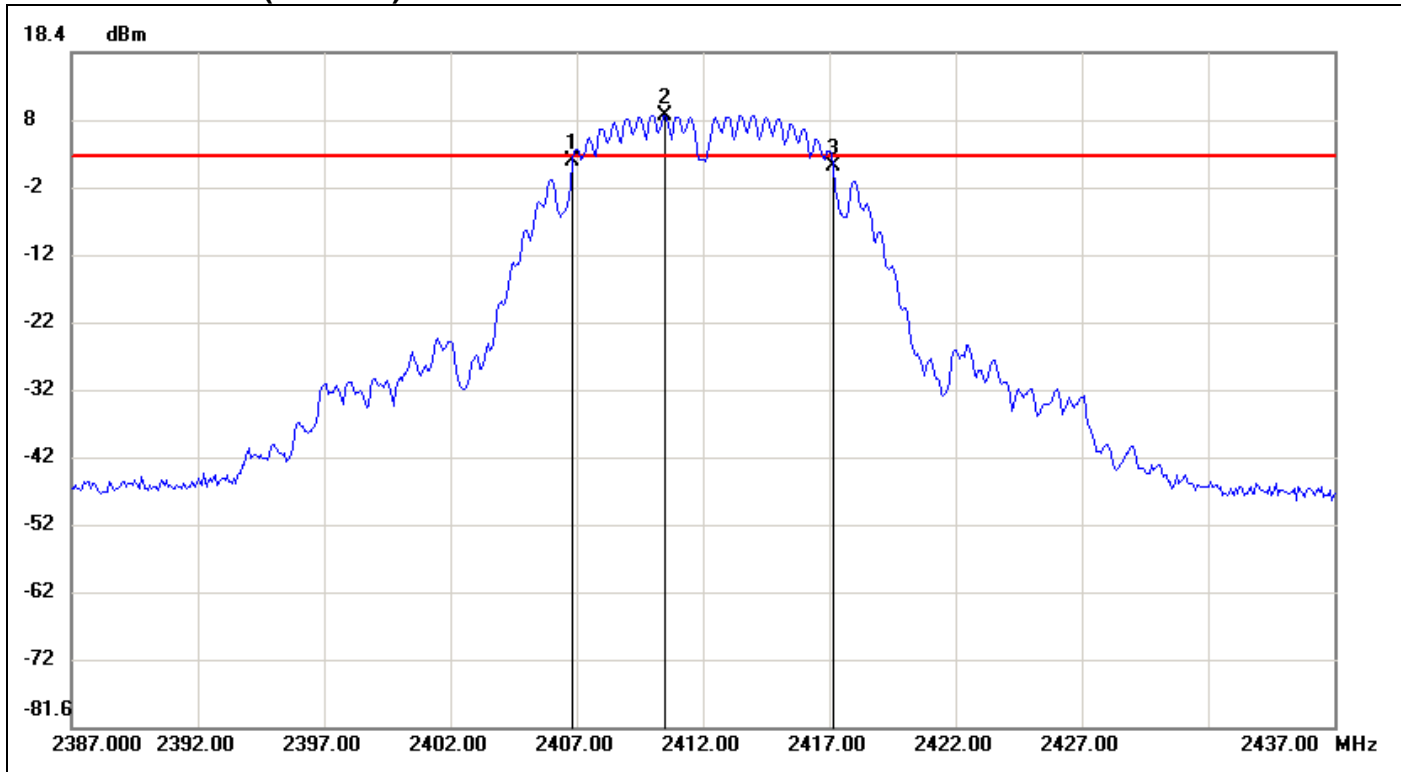

No.	Frequency(MHz)	Result(dBm)	Limit(dBm)	Margin(dBm)
1	2406.8333	2.27	3.16	-0.89
2	2410.5000	9.16	3.16	6.00
3	2417.1667	1.47	3.16	-1.69

No.		$\Delta$ Frequency(MHz)	$\Delta$ Level(dB)
1	mk3-mk1	10.3334	-0.8



**6dB Bandwidth (CH Mid)**

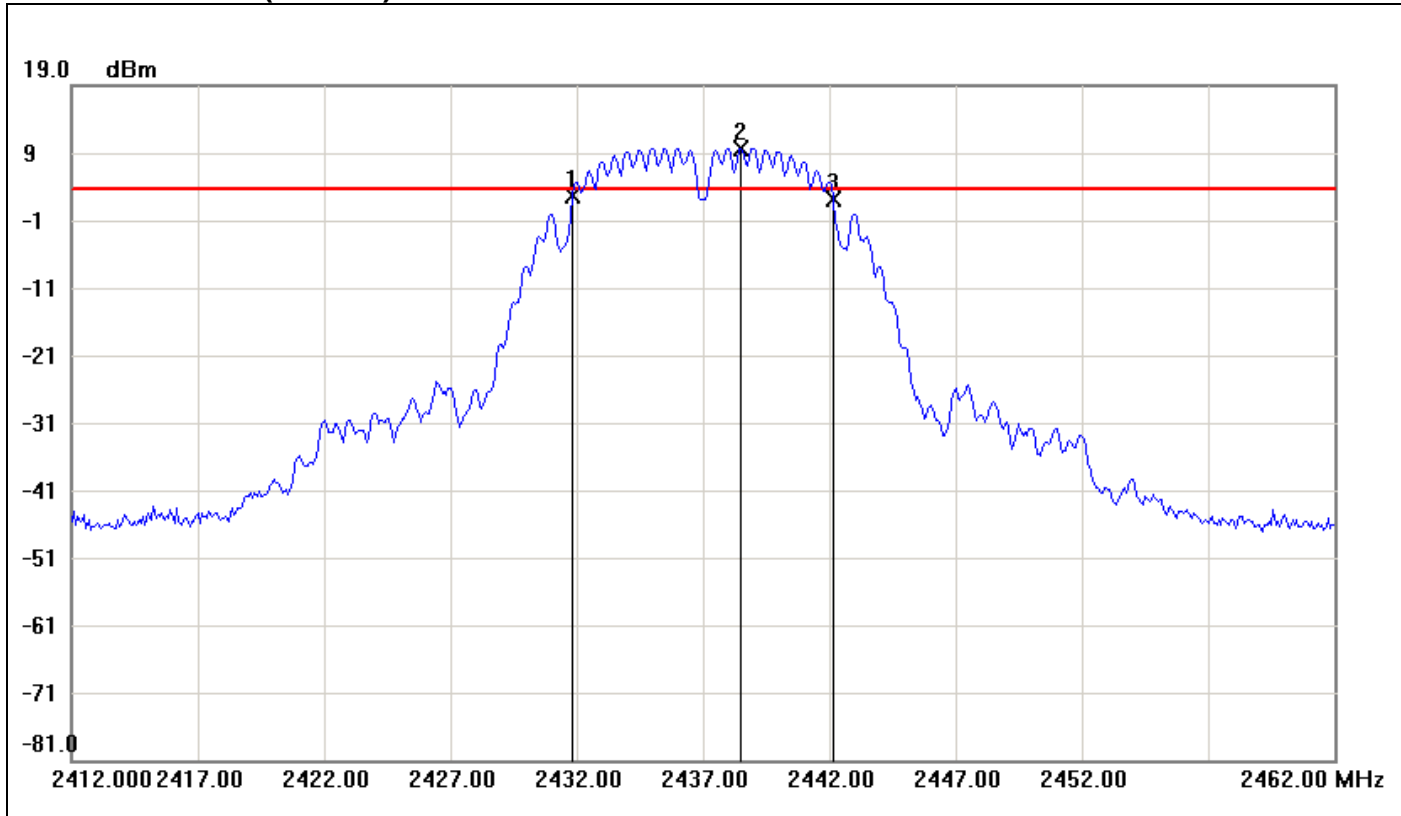

No.	Frequency(MHz)	Result(dBm)	Limit(dBm)	Margin(dBm)
1	2431.8333	2.70	3.70	-1.00
2	2438.5000	9.70	3.70	6.00
3	2442.1667	2.17	3.70	-1.53

No.		$\Delta$ Frequency(MHz)	$\Delta$ Level(dB)
1	mk3-mk1	10.3334	-0.53

**6dB Bandwidth (CH High)**

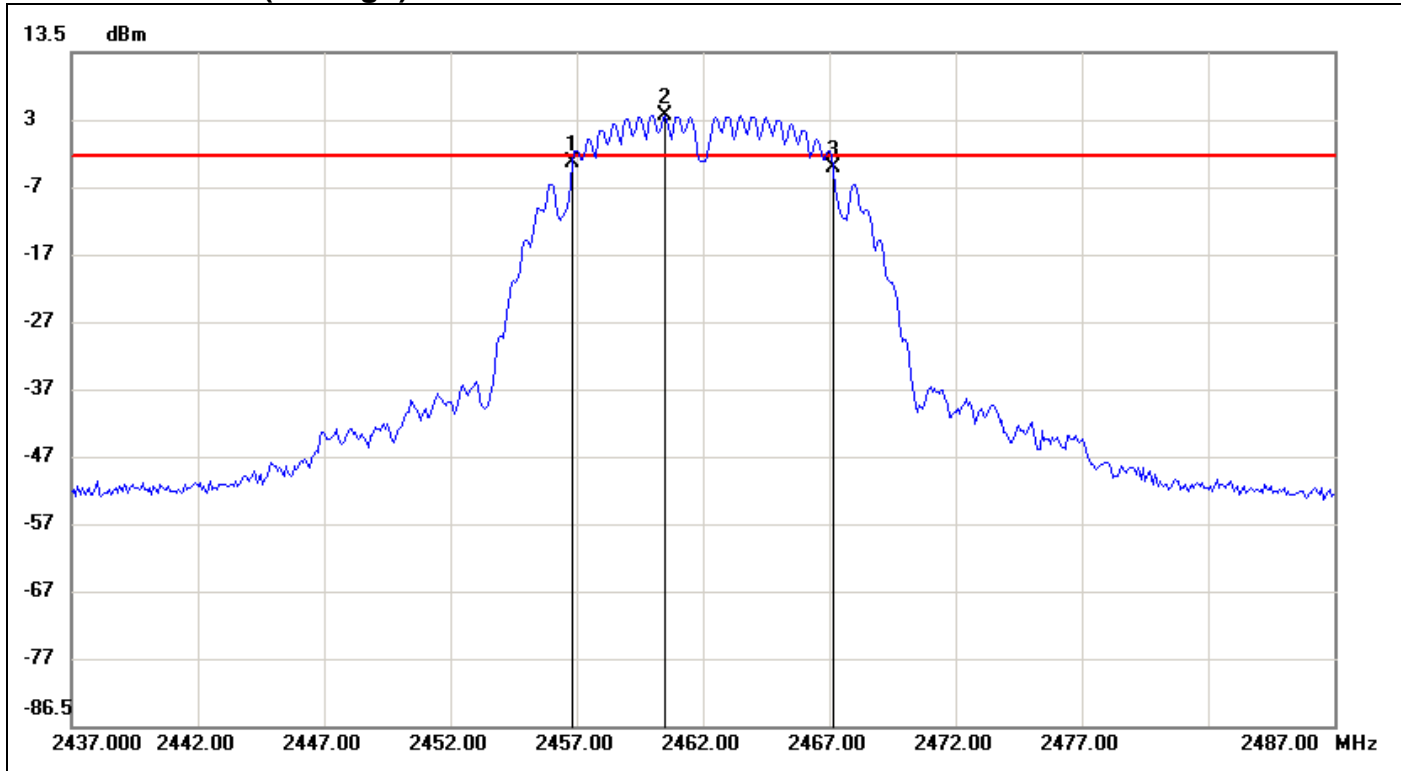

No.	Frequency(MHz)	Result(dBm)	Limit(dBm)	Margin(dBm)
1	2456.8333	-2.83	-1.95	-0.88
2	2460.5000	4.05	-1.95	6.00
3	2467.1667	-3.57	-1.95	-1.62

No.		$\Delta$ Frequency(MHz)	$\Delta$ Level(dB)
1	mk3-mk1	10.3334	-0.74

**IEEE 802.11g mode**

**6dB Bandwidth (CH Low)**

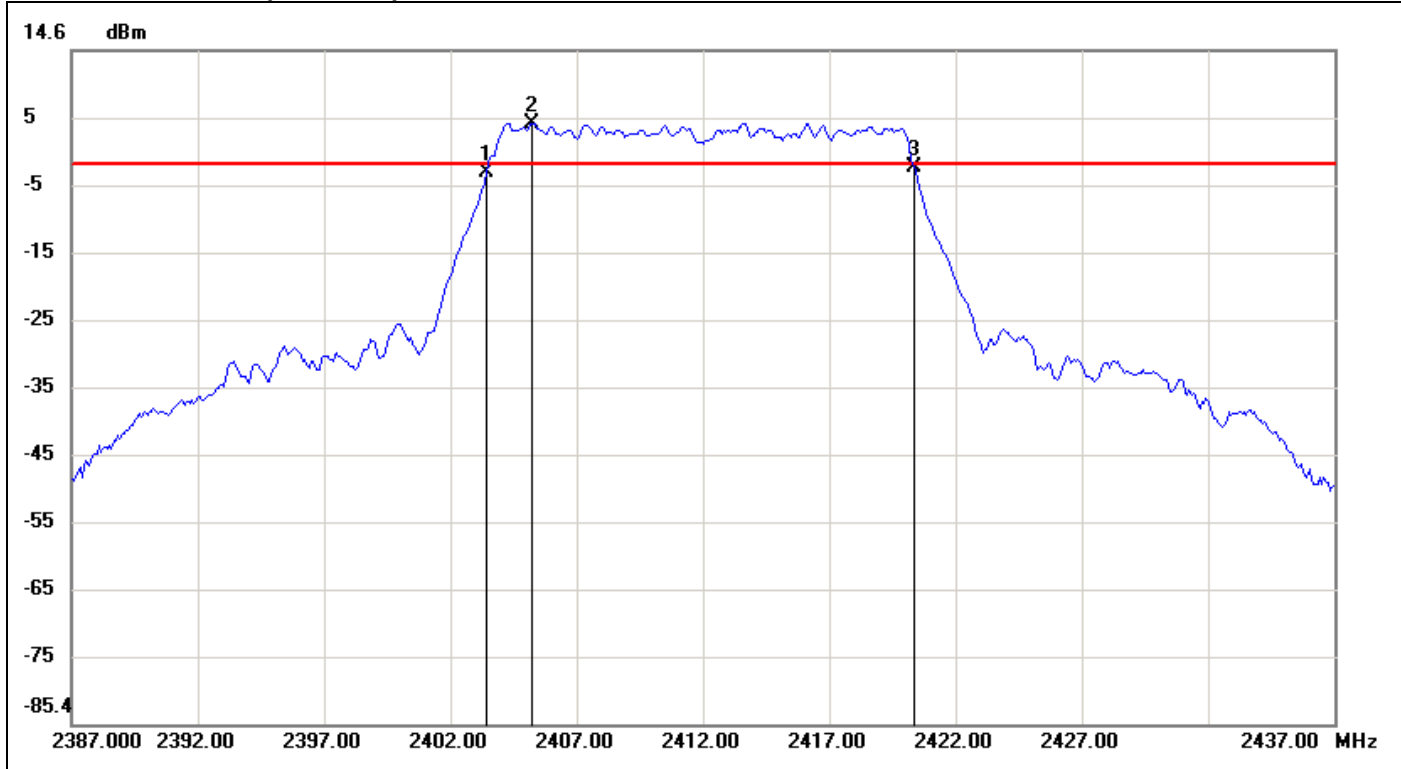

No.	Frequency(MHz)	Result(dBm)	Limit(dBm)	Margin(dBm)
1	2403.4167	-3.60	-2.28	-1.32
2	2405.2500	3.72	-2.28	6.00
3	2420.3333	-2.71	-2.28	-0.43

No.		$\Delta$ Frequency(MHz)	$\Delta$ Level(dB)
1	mk3-mk1	16.9166	0.89

**6dB Bandwidth (CH Mid)**

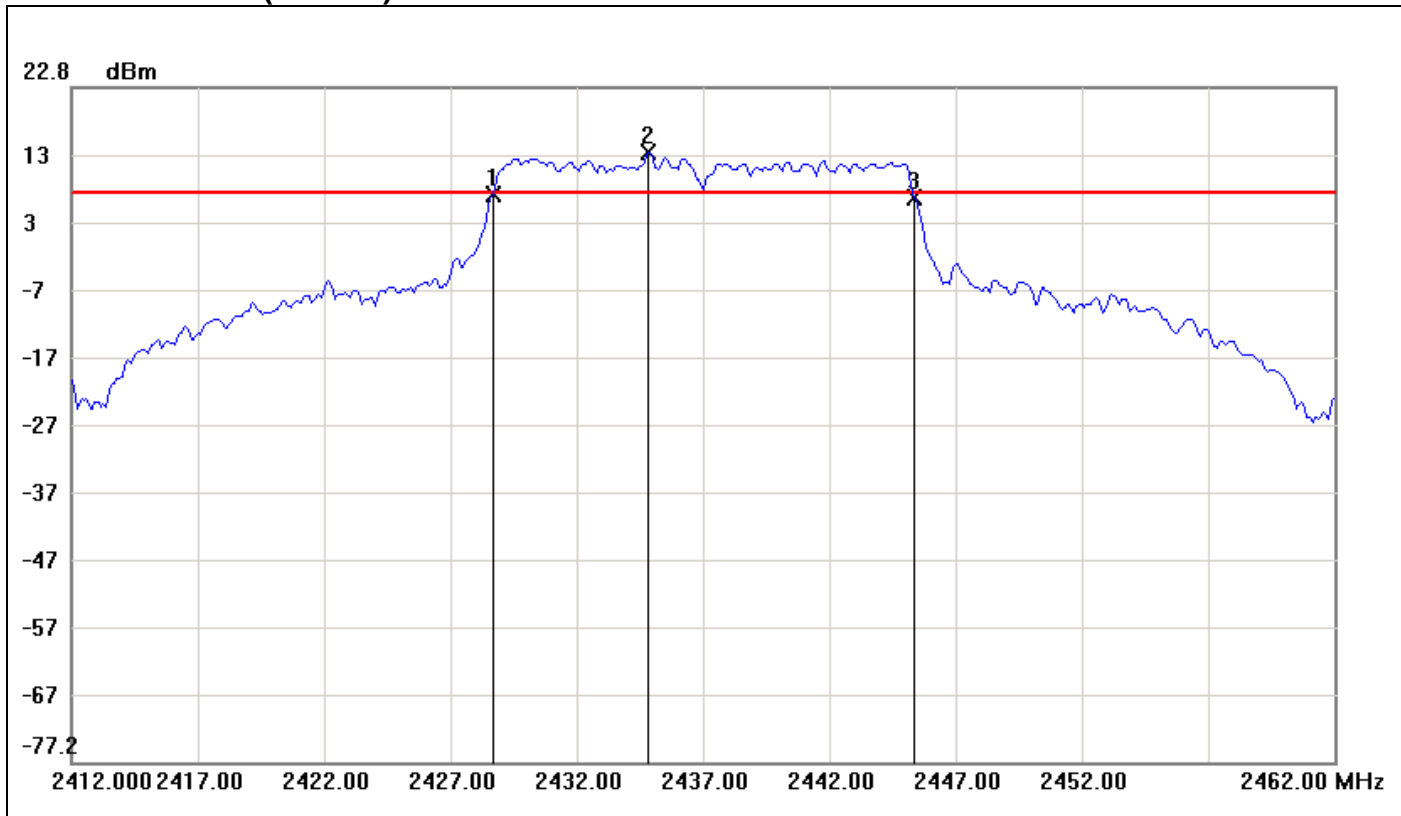

No.	Frequency(MHz)	Result(dBm)	Limit(dBm)	Margin(dBm)
1	2428.6667	6.83	7.07	-0.24
2	2434.8333	13.07	7.07	6.00
3	2445.3333	6.41	7.07	-0.66

No.		$\Delta$ Frequency(MHz)	$\Delta$ Level(dB)
1	mk3-mk1	16.6666	-0.42

**6dB Bandwidth (CH High)**

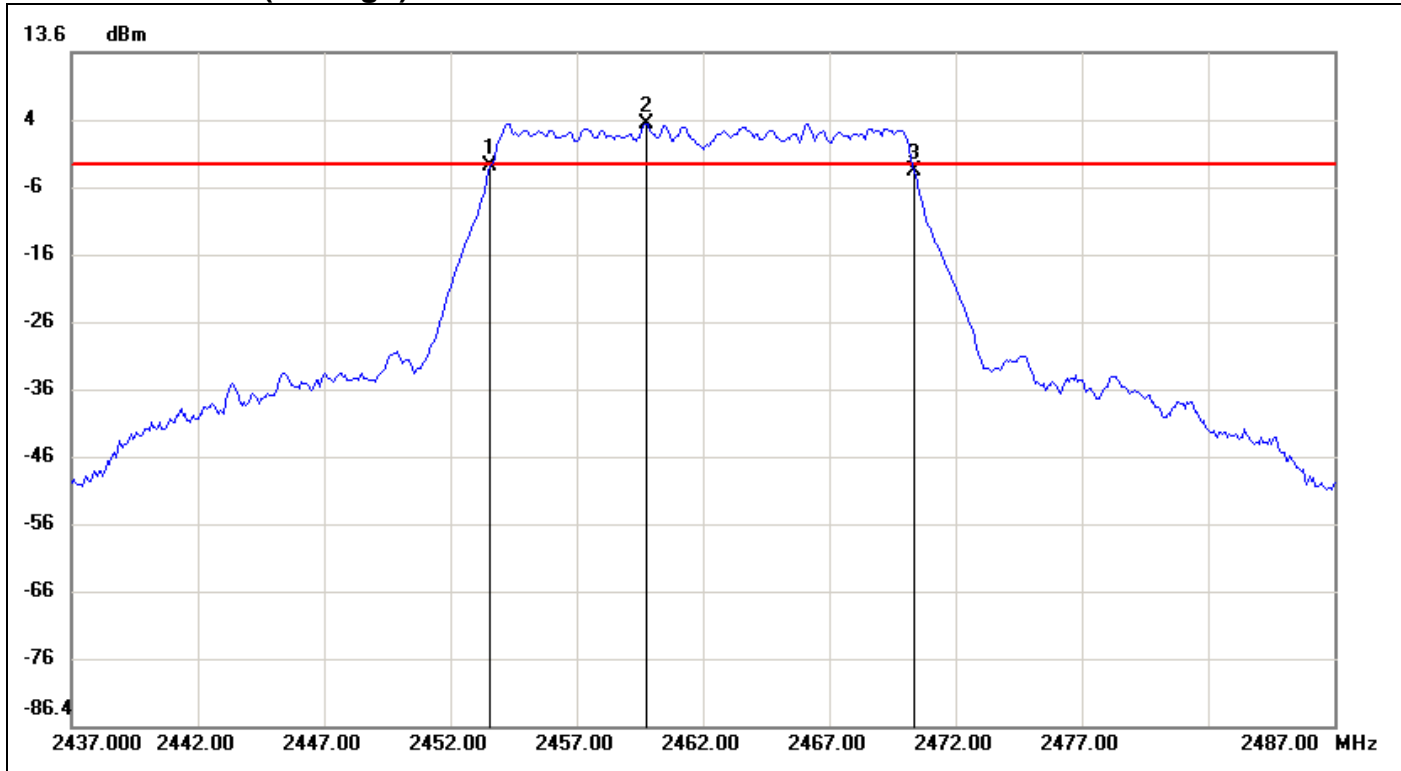

No.	Frequency(MHz)	Result(dBm)	Limit(dBm)	Margin(dBm)
1	2453.5833	-3.18	-2.87	-0.31
2	2459.7500	3.13	-2.87	6.00
3	2470.3333	-3.98	-2.87	-1.11

No.		$\Delta$ Frequency(MHz)	$\Delta$ Level(dB)
1	mk3-mk1	16.75	-0.8

**IEEE 802.11n HT 20 mode / Chain 0**

**6dB Bandwidth (CH Low)**

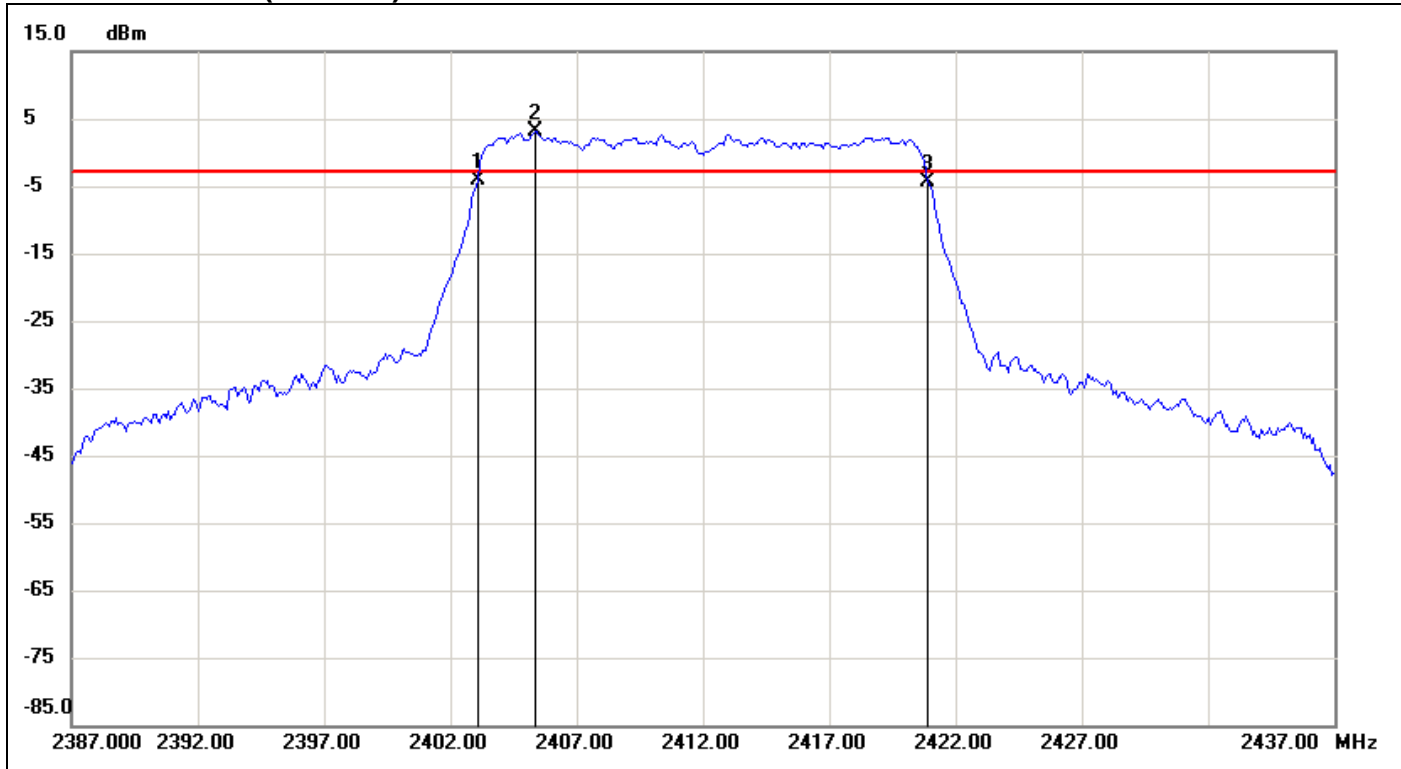

No.	Frequency(MHz)	Result(dBm)	Limit(dBm)	Margin(dBm)
1	2403.0833	-4.09	-2.86	-1.23
2	2405.3333	3.14	-2.86	6.00
3	2420.9167	-4.39	-2.86	-1.53

No.		$\Delta$ Frequency(MHz)	$\Delta$ Level(dB)
1	mk3-mk1	17.8334	-0.3

**6dB Bandwidth (CH Mid)**

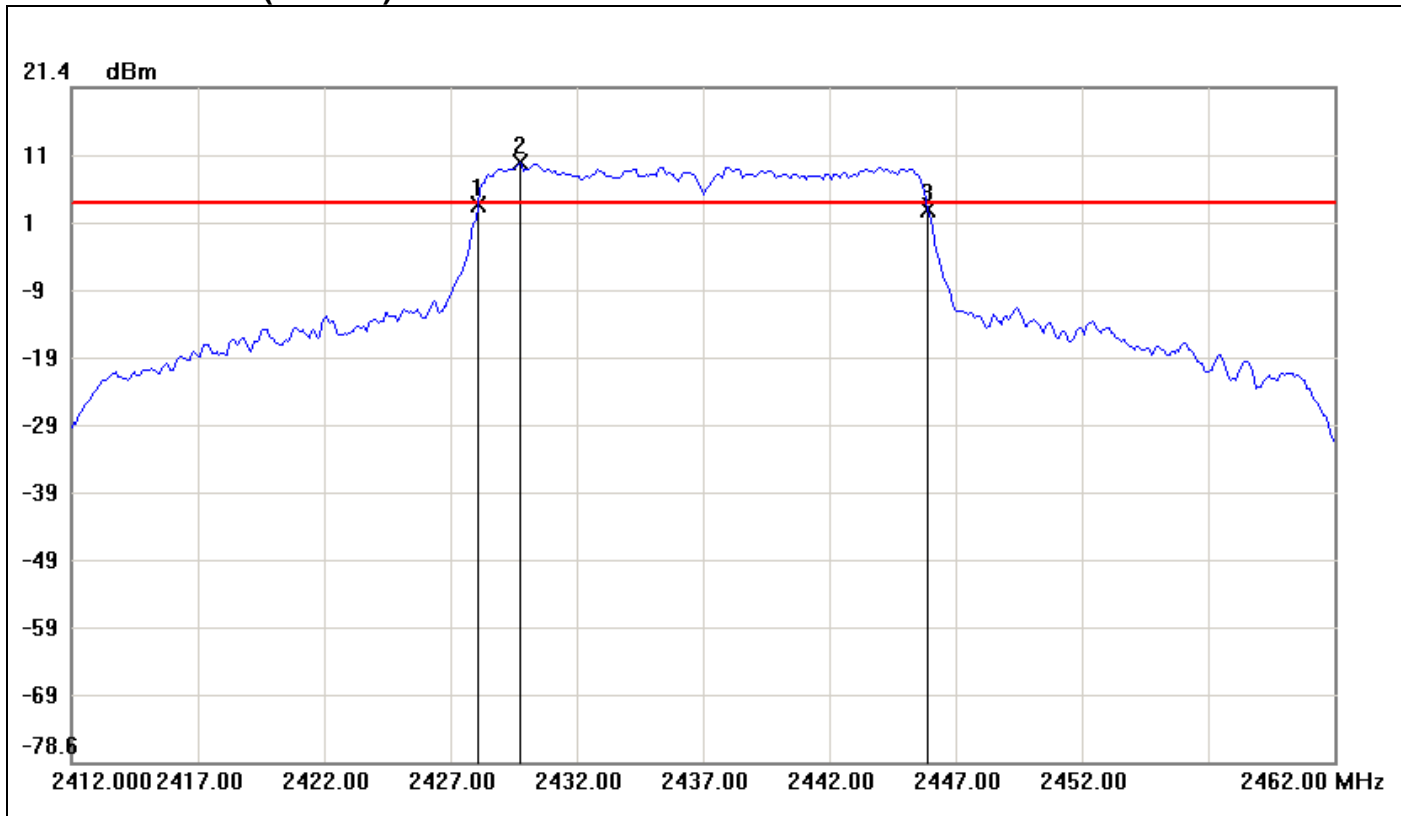

No.	Frequency(MHz)	Result(dBm)	Limit(dBm)	Margin(dBm)
1	2428.0833	4.01	4.29	-0.28
2	2429.7500	10.29	4.29	6.00
3	2445.9167	3.43	4.29	-0.86

No.		$\Delta$ Frequency(MHz)	$\Delta$ Level(dB)
1	mk3-mk1	17.8334	-0.58

**6dB Bandwidth (CH High)**

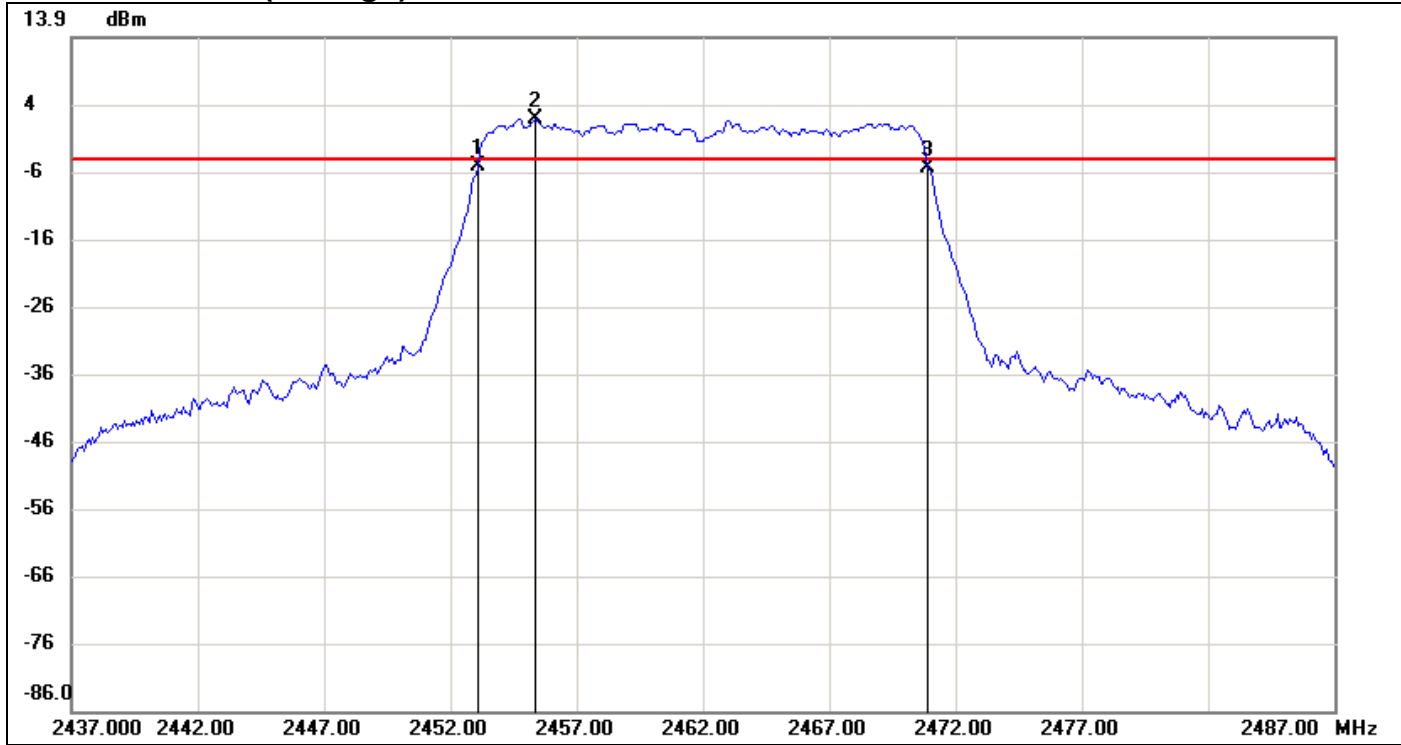

No.	Frequency(MHz)	Result(dBm)	Limit(dBm)	Margin(dBm)
1	2453.0833	-5.07	-4.05	-1.02
2	2455.3333	1.95	-4.05	6.00
3	2470.9167	-5.30	-4.05	-1.25

No.		$\Delta$ Frequency(MHz)	$\Delta$ Level(dB)
1	mk3-mk1	17.8334	-0.23



**IEEE 802.11n HT 20 mode / Chain 1**

**6dB Bandwidth (CH Low)**

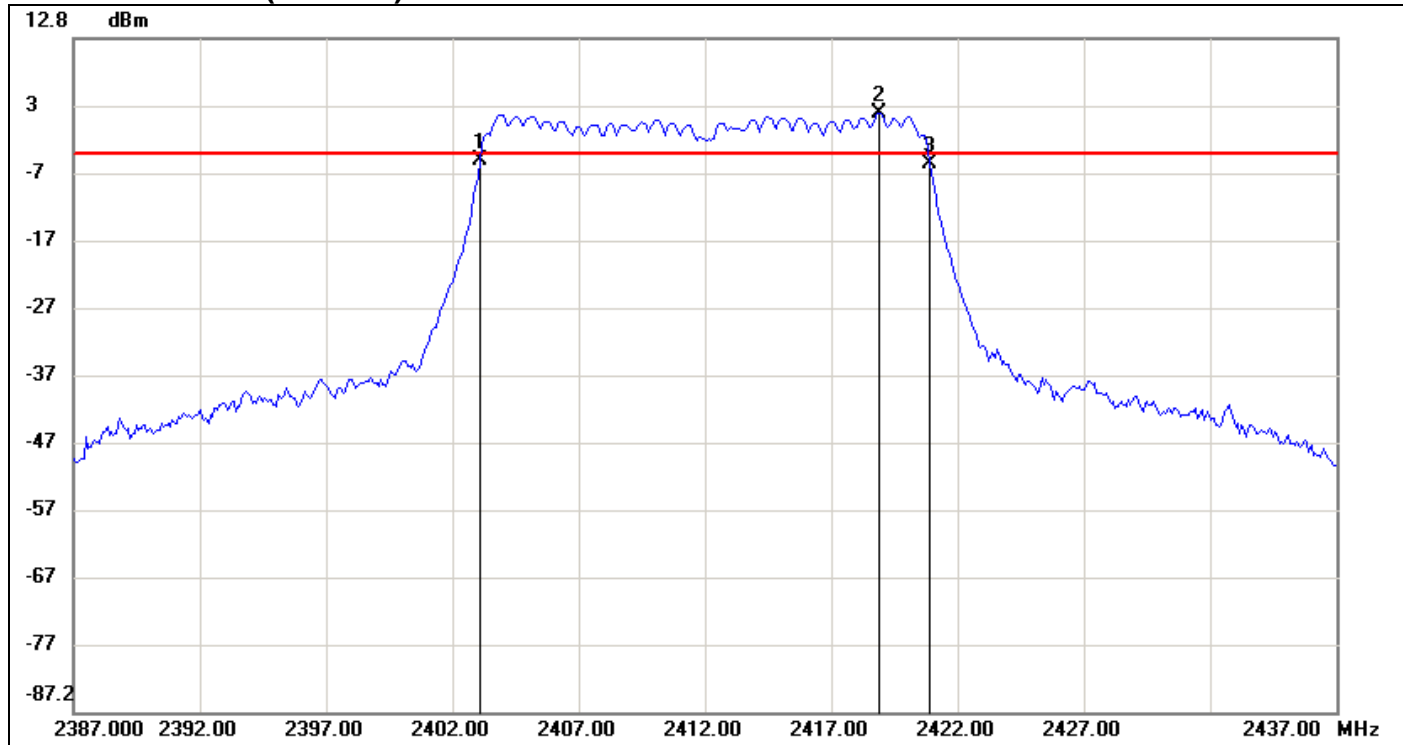

No.	Frequency(MHz)	Result(dBm)	Limit(dBm)	Margin(dBm)
1	2403.0833	-5.19	-4.38	-0.81
2	2418.9167	1.62	-4.38	6.00
3	2420.9167	-5.87	-4.38	-1.49

No.		$\Delta$ Frequency(MHz)	$\Delta$ Level(dB)
1	mk3-mk1	17.8334	-0.68

**6dB Bandwidth (CH Mid)**

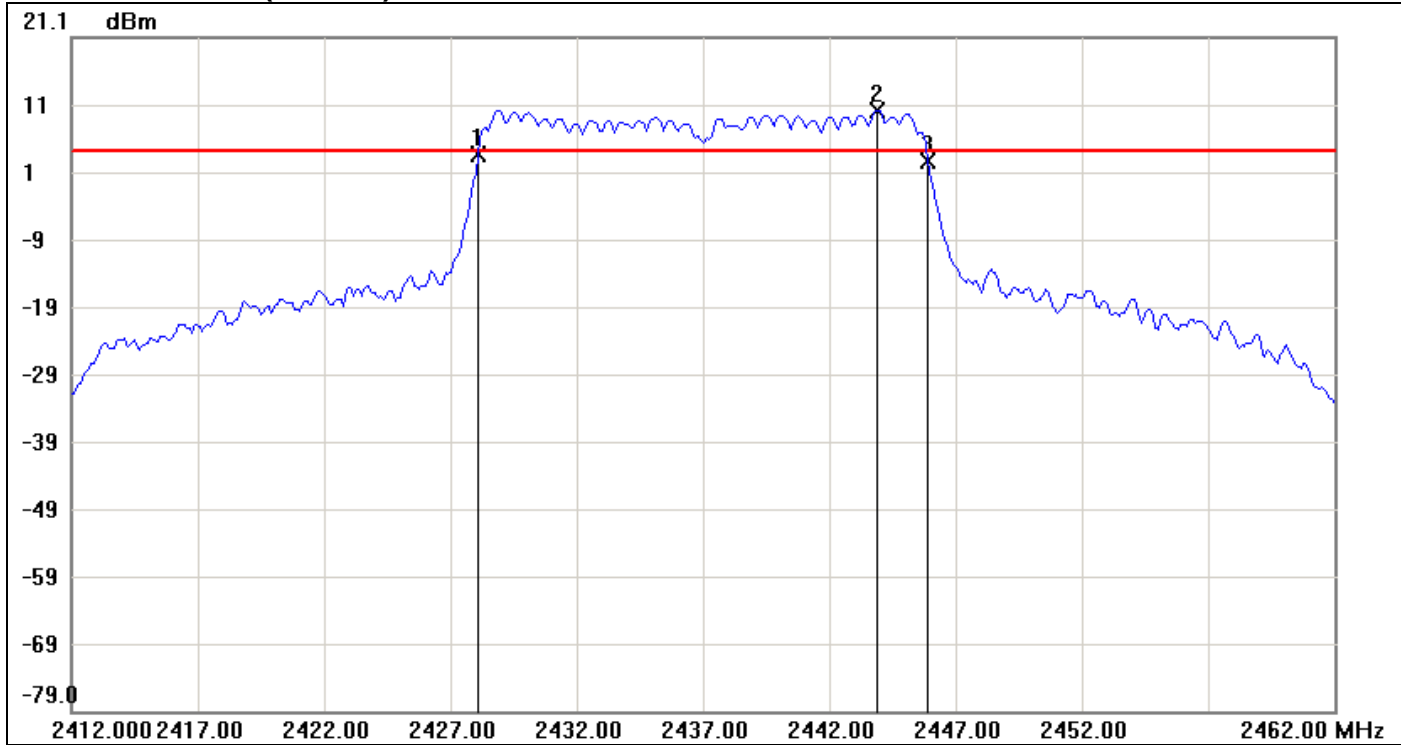

No.	Frequency(MHz)	Result(dBm)	Limit(dBm)	Margin(dBm)
1	2428.0833	3.72	4.21	-0.49
2	2443.9167	10.21	4.21	6.00
3	2445.9167	2.78	4.21	-1.43

No.		$\Delta$ Frequency(MHz)	$\Delta$ Level(dB)
1	mk3-mk1	17.8334	-0.94

**6dB Bandwidth (CH High)**

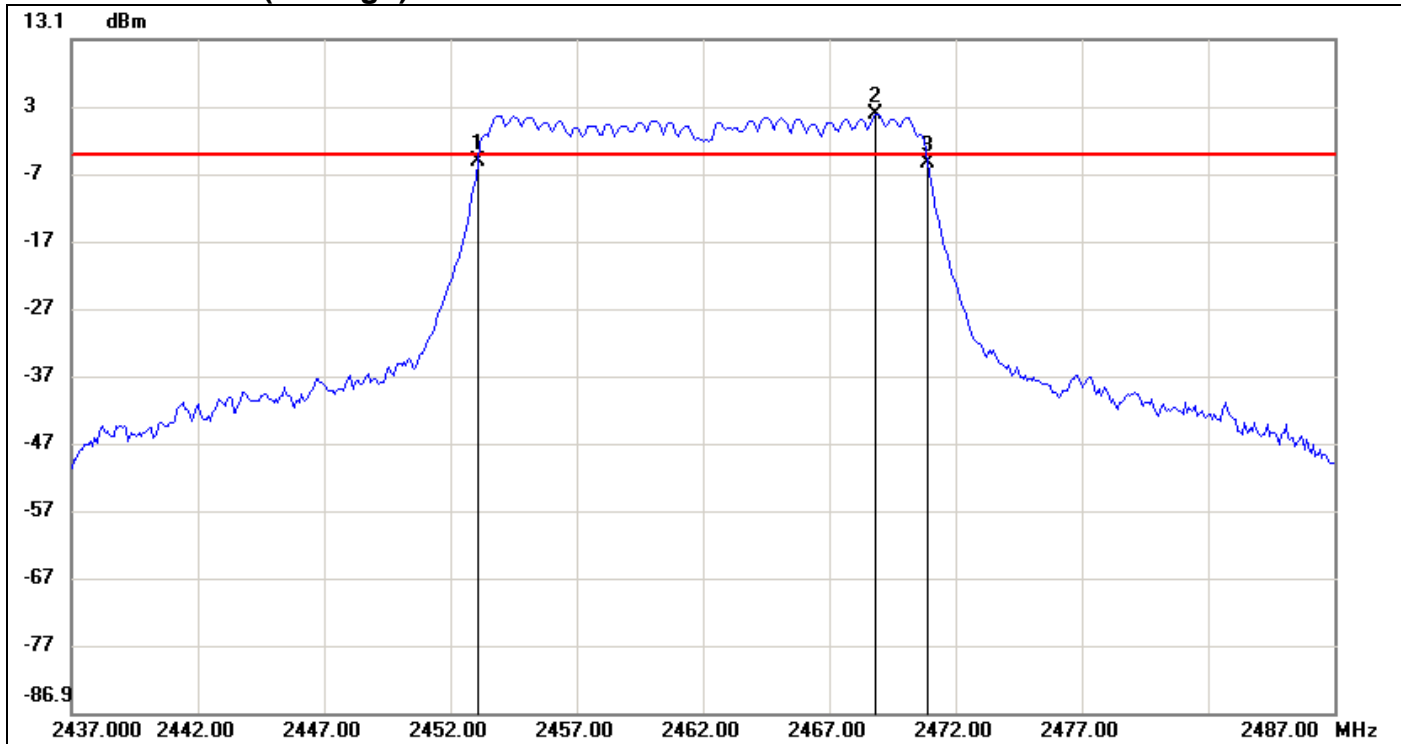

No.	Frequency(MHz)	Result(dBm)	Limit(dBm)	Margin(dBm)
1	2453.0833	-4.94	-4.04	-0.90
2	2468.8333	1.96	-4.04	6.00
3	2470.9167	-5.23	-4.04	-1.19

No.		$\Delta$ Frequency(MHz)	$\Delta$ Level(dB)
1	mk3-mk1	17.8334	-0.29

**IEEE 802.11n HT 40 mode / Chain 0**

**6dB Bandwidth (CH Low)**

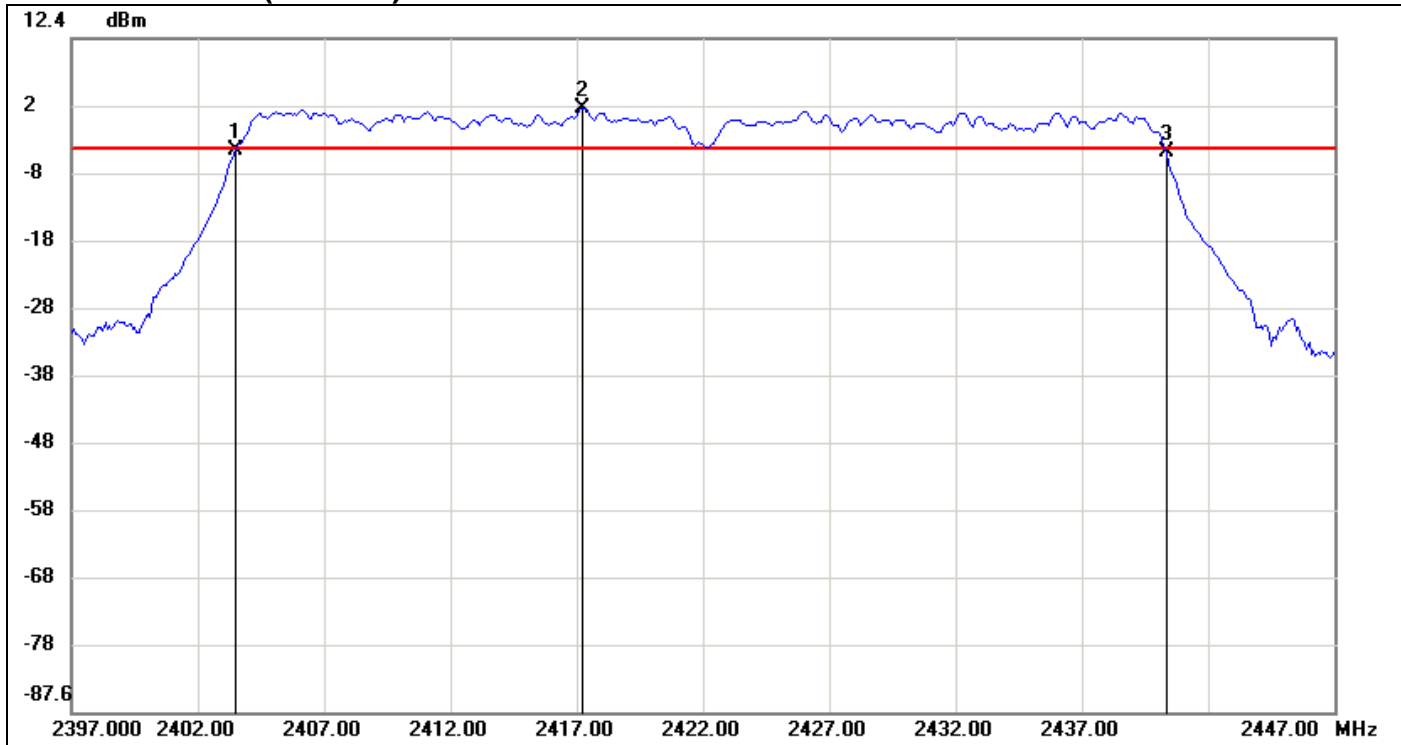

No.	Frequency(MHz)	Result(dBm)	Limit(dBm)	Margin(dBm)
1	2403.5000	-4.15	-3.83	-0.32
2	2417.2500	2.17	-3.83	6.00
3	2440.3333	-4.50	-3.83	-0.67

No.		$\Delta$ Frequency(MHz)	$\Delta$ Level(dB)
1	mk3-mk1	36.8333	-0.35

**6dB Bandwidth (CH Mid)**

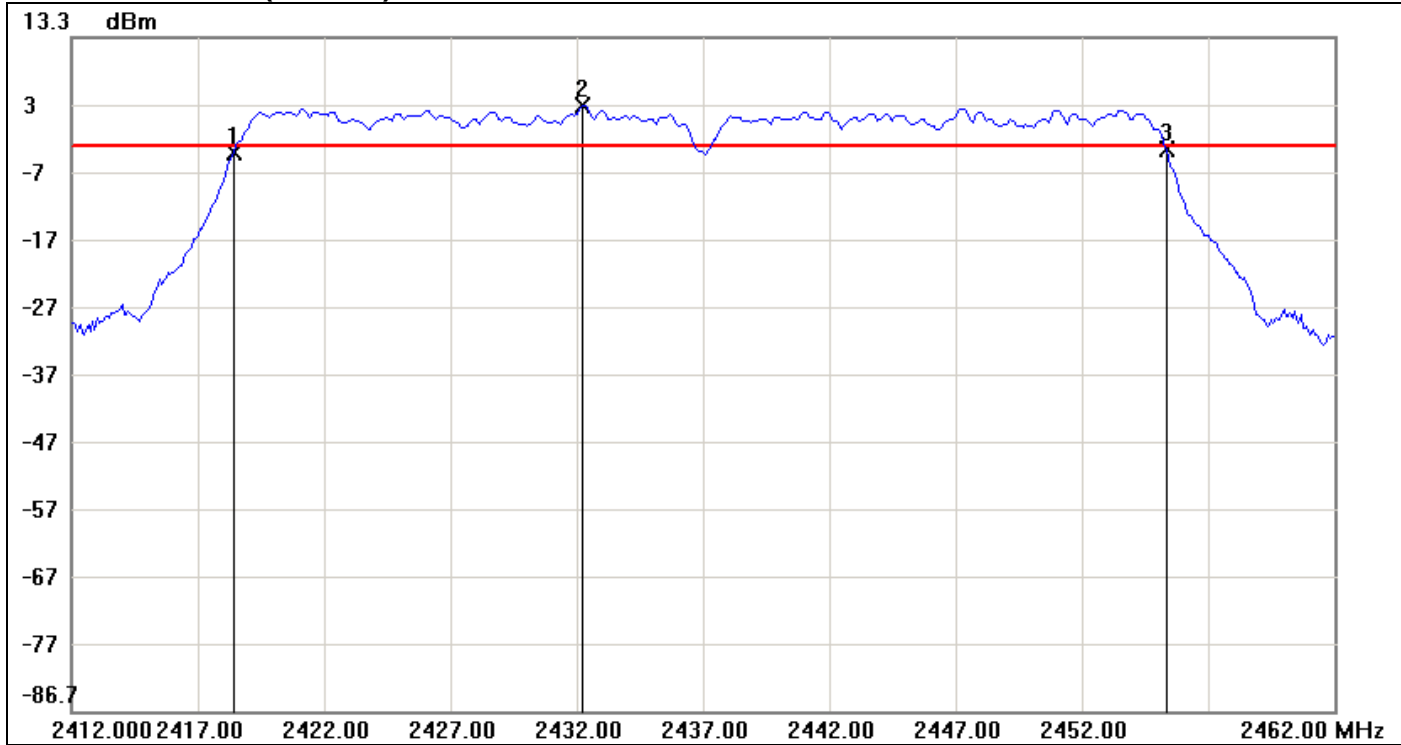

No.	Frequency(MHz)	Result(dBm)	Limit(dBm)	Margin(dBm)
1	2418.4167	-3.80	-2.93	-0.87
2	2432.2500	3.07	-2.93	6.00
3	2455.3333	-3.32	-2.93	-0.39

No.		$\Delta$ Frequency(MHz)	$\Delta$ Level(dB)
1	mk3-mk1	36.9166	0.48

**6dB Bandwidth (CH High)**

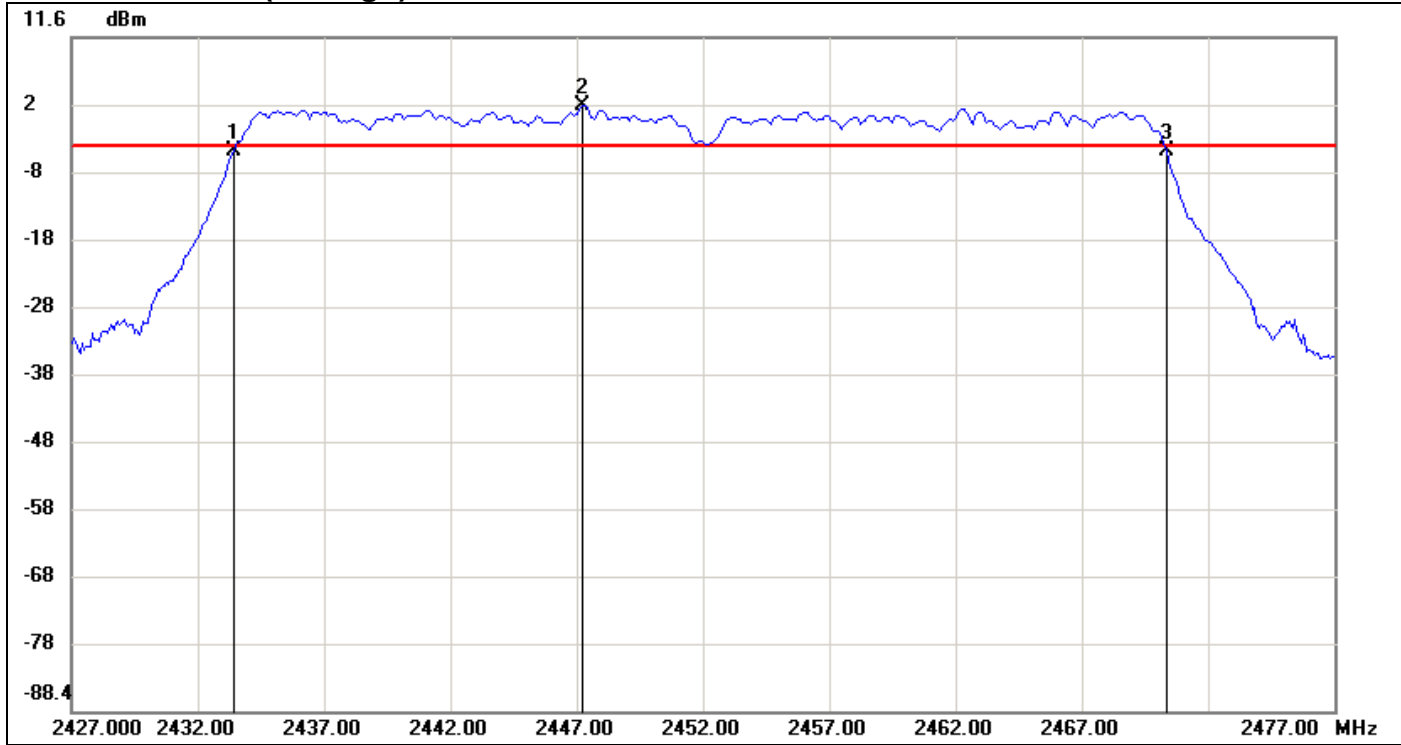

No.	Frequency(MHz)	Result(dBm)	Limit(dBm)	Margin(dBm)
1	2433.4167	-5.13	-4.55	-0.58
2	2447.2500	1.45	-4.55	6.00
3	2470.3333	-5.22	-4.55	-0.67

No.		$\Delta$ Frequency(MHz)	$\Delta$ Level(dB)
1	mk3-mk1	36.9166	-0.09

**IEEE 802.11n HT 40 mode / Chain 1**

**6dB Bandwidth (CH Low)**

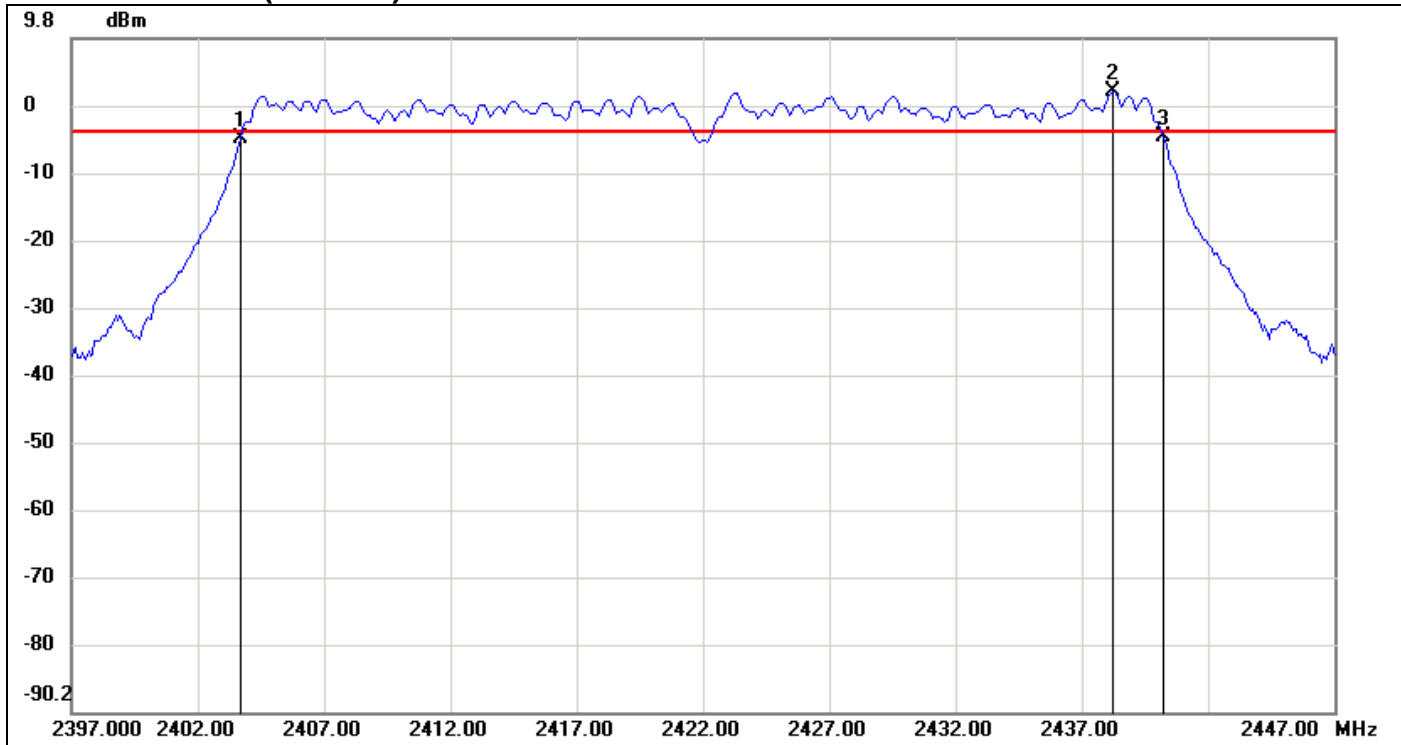

No.	Frequency(MHz)	Result(dBm)	Limit(dBm)	Margin(dBm)
1	2403.6667	-5.08	-4.18	-0.90
2	2438.2500	1.82	-4.18	6.00
3	2440.2500	-4.87	-4.18	-0.69

No.		$\Delta$ Frequency(MHz)	$\Delta$ Level(dB)
1	mk3-mk1	36.5833	0.21

**6dB Bandwidth (CH Mid)**

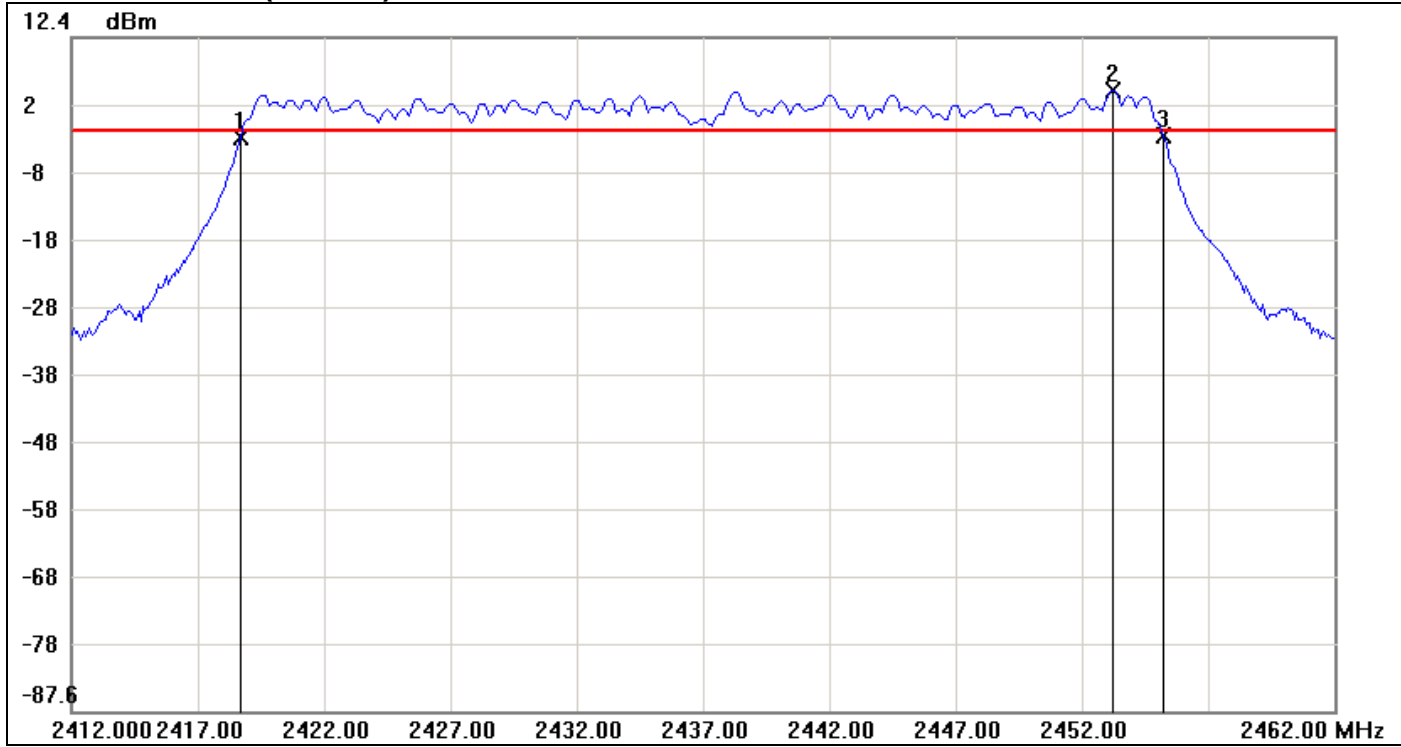

No.	Frequency(MHz)	Result(dBm)	Limit(dBm)	Margin(dBm)
1	2418.6667	-2.37	-1.50	-0.87
2	2453.2500	4.50	-1.50	6.00
3	2455.2500	-2.29	-1.50	-0.79

No.		$\Delta$ Frequency(MHz)	$\Delta$ Level(dB)
1	mk3-mk1	36.5833	0.08



**6dB Bandwidth (CH High)**

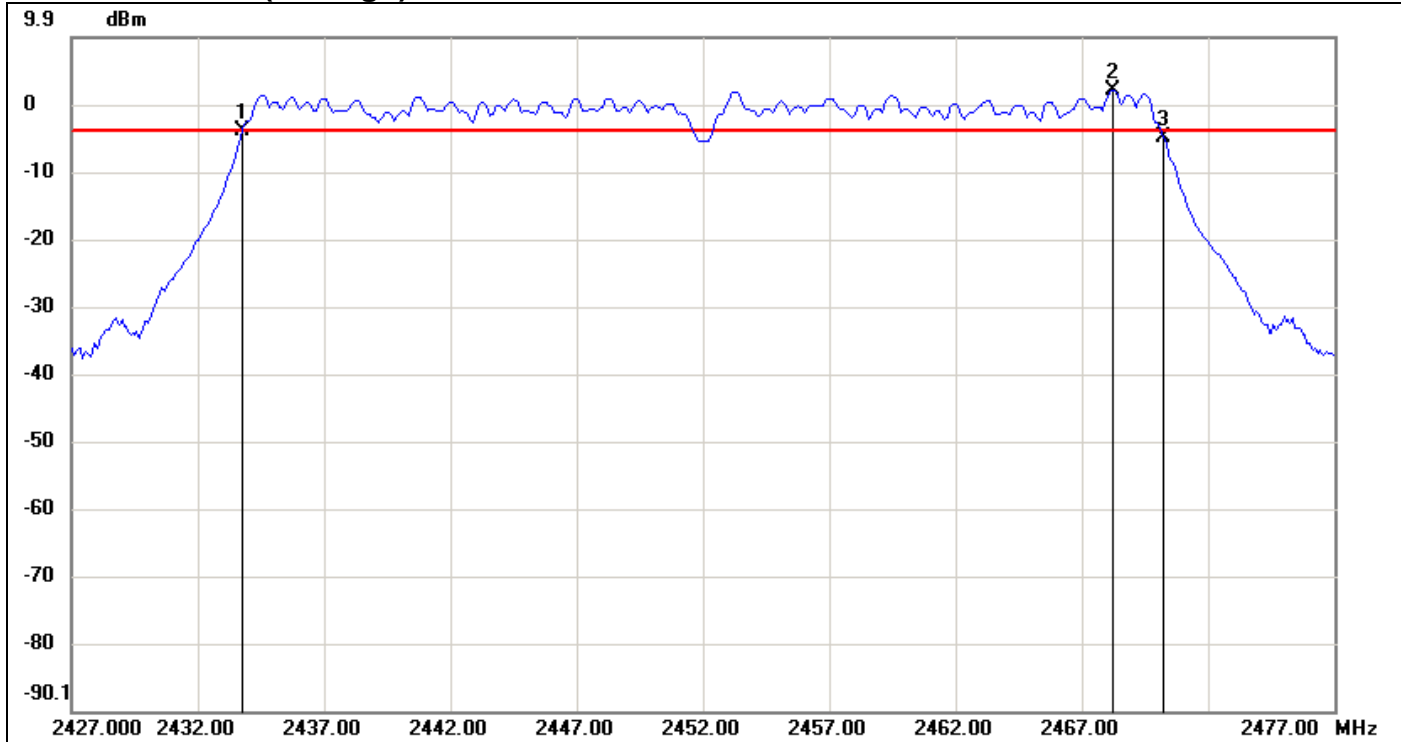

No.	Frequency(MHz)	Result(dBm)	Limit(dBm)	Margin(dBm)
1	2433.7500	-3.99	-3.98	-0.01
2	2468.2500	2.02	-3.98	6.00
3	2470.2500	-4.87	-3.98	-0.89

No.		$\Delta$ Frequency(MHz)	$\Delta$ Level(dB)
1	mk3-mk1	36.5	-0.88

## 7.2 PEAK POWER

### LIMIT

The maximum peak output power of the intentional radiator shall not exceed the following:

1. According to §15.247(b)(3), for systems using digital modulation in the bands of 902-928 MHz, 2400-2483.5 MHz, and 5725-5850 MHz: 1 Watt.
2. According to §15.247(b)(4), the conducted output power limit specified in paragraph (b) of this section is based on the use of antennas with directional gains that do not exceed 6 dBi. Except as shown in paragraph (c) of this section, if transmitting antennas of directional gain greater than 6 dBi are used, the conducted output power from the intentional radiator shall be reduced below the stated values in paragraphs (b)(1), (b)(2), and (b)(3) of this section, as appropriate, by the amount in dB that the directional gain of the antenna exceeds 6 dBi.

### Test Configuration

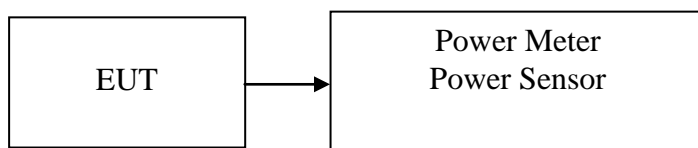

### TEST PROCEDURE

The transmitter output is connected to the Power Meter. The Power Meter is set to the peak power detection.

**Test Data**

**Test mode: IEEE 802.11b mode**

Channel	Frequency (MHz)	Output Power (dBm)	Output Power (W)	Limit (dBm)	Result
Low	2412	<b>21.77</b>	0.1503	30	PASS
Mid	2437	21.47	0.1403		PASS
High	2462	21.25	0.1334		PASS

**Test mode: IEEE 802.11g mode**

Channel	Frequency (MHz)	Output Power (dBm)	Output Power (W)	Limit (dBm)	Result
Low	2412	23.39	0.2183	30	PASS
Mid	2437	<b>25.25</b>	0.3350		PASS
High	2462	23.94	0.2477		PASS

**Test mode: IEEE 802.11n HT 20 mode**

Channel	Frequency (MHz)	Chain 0 Output Power (dBm)	Chain 1 Output Power (dBm)	Total Output Power (dBm)	Output Power (W)	Limit (dBm)	Result
Low	2412	23.11	20.72	25.09	0.3228	30	PASS
Mid	2437	24.33	24.63	<b>27.49</b>	0.5610		PASS
High	2462	22.74	21.23	25.06	0.3206		PASS

**Test mode: IEEE 802.11n HT 40 mode**

Channel	Frequency (MHz)	Chain 0 Output Power (dBm)	Chain 1 Output Power (dBm)	Total Output Power (dBm)	Output Power (W)	Limit (dBm)	Result
Low	2422	20.01	19.02	22.55	0.1799	30	PASS
Mid	2437	22.12	21.03	<b>24.62</b>	0.2897		PASS
High	2452	21.95	20.78	24.41	0.2761		PASS

**Remark:** Total Output Power (w) = Chain 0 (10^(Output Power /10)/1000)+ Chain 1 (10^(Output Power /10)/1000 )

## 7.3 AVERAGE POWER

### LIMIT

None; for reporting purposes only.

### Test Configuration

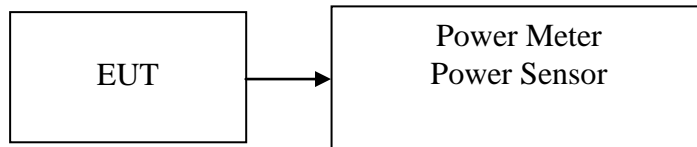

### TEST PROCEDURE

The transmitter output is connected to the Power Meter. The Power Meter is set to the avg power detection.

## **TEST RESULTS**

*No non-compliance noted*

### **Test Data**

#### **Test mode: IEEE 802.11b mode**

Channel	Frequency (MHz)	Output Power (dBm)	Output Power (W)
Low	2412	18.66	0.0735
Mid	2437	18.23	0.0665
High	2462	17.89	0.0615

#### **Test mode: IEEE 802.11g mode**

Channel	Frequency (MHz)	Output Power (dBm)	Output Power (W)
Low	2412	16.09	0.0406
Mid	2437	20.90	0.1230
High	2462	16.04	0.0402

#### **Test mode: IEEE 802.11n HT 20 mode**

Channel	Frequency (MHz)	Chain 0 Output Power (dBm)	Chain 1 Output Power (dBm)	Total Output Power (dBm)	Output Power (W)
Low	2412	15.64	12.52	17.36	0.0545
Mid	2437	18.70	18.49	21.61	0.1449
High	2462	14.43	13.03	16.80	0.0479

#### **Test mode: IEEE 802.11n HT 40 mode**

Channel	Frequency (MHz)	Chain 0 Output Power (dBm)	Chain 1 Output Power (dBm)	Total Output Power (dBm)	Output Power (W)
Low	2422	11.13	10.23	13.71	0.0235
Mid	2437	14.06	12.52	16.37	0.0434
High	2452	13.52	12.31	15.97	0.0395

**Remark:** Total Output Power (w) = Chain 0 (10^(Output Power /10)/1000)+ Chain 1 (10^(Output Power /10)/1000

)

## 7.4 BAND EDGES MEASUREMENT

### LIMIT

According to §15.247(d), in any 100 kHz bandwidth outside the frequency bands in which the spread spectrum intentional radiator is operating, the radio frequency power that is produced by the intentional radiator shall be at least 20 dB below that in the 100 kHz bandwidth within the band that contains the highest level of the desired power, based on either an RF conducted or a radiated measurement, provided the transmitter demonstrates compliance with the peak conducted power limits. In addition, radiated emissions which fall in the restricted bands, as defined in §15.205(a), must also comply with the radiated emission limits specified in 15.209(a) (see Section 15.205(c)).

### Test Configuration

#### For Radiated

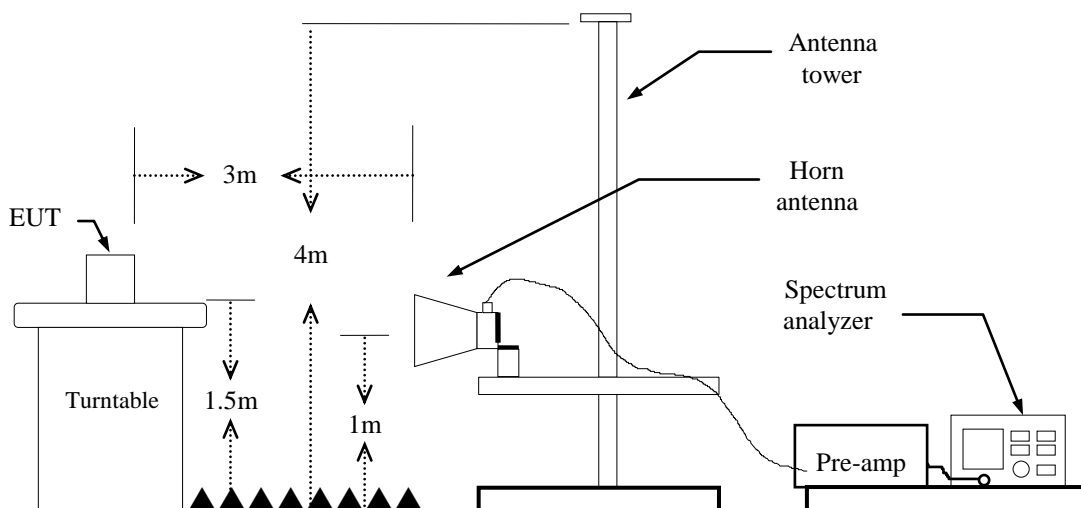

#### For Conducted

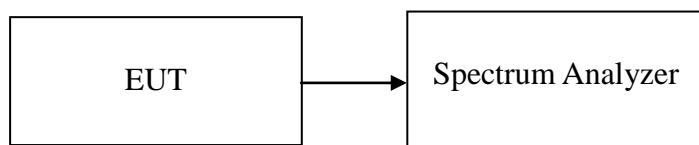

## **TEST PROCEDURE**

### **For Radiated**

1. The EUT is placed on a turntable, which is 1.5m above the ground plane.
2. The turntable shall be rotated for 360 degrees to determine the position of maximum emission level.
3. EUT is set 3m away from the receiving antenna, which is varied from 1m to 4m to find out the highest emission.
4. Set the spectrum analyzer in the following setting in order to capture the lower and upper band-edges of the emission:
  - (a) PEAK: RBW=VBW=3MHz / Sweep=AUTO
  - (b) AVERAGE: RBW=1MHz,  
if duty cycle  $\geq$  98%, VBW=10Hz.  
if duty cycle < 98% VBW=1/T.  
IEEE 802.11b mode:  $\geq$  98%, VBW=10Hz  
IEEE 802.11g mode:  $\geq$  98%, VBW=10Hz  
IEEE 802.11n HT 20 MHz mode:  $\geq$  98%, VBW=10Hz  
IEEE 802.11n HT 40 MHz mode:  $\geq$  98%=VBW 10Hz
5. Repeat the procedures until all the PEAK and AVERAGE versus POLARIZATION are measured.

### **For Conducted**

Conducted RF measurements of the transmitter output were made to confirm that the EUT antenna port conducted emissions meet the specified limit and to identify any spurious signals that require further investigation or measurements on the radiated emissions site.

The transmitter output is connected to the spectrum analyzer. The resolution bandwidth is set to 100 kHz. The video bandwidth is set to 300 kHz.

## **TEST RESULTS**

Refer to attach spectrum analyzer data chart.

**Band Edges (IEEE 802.11b mode / CH Low)**

**Polarity: Vertical**

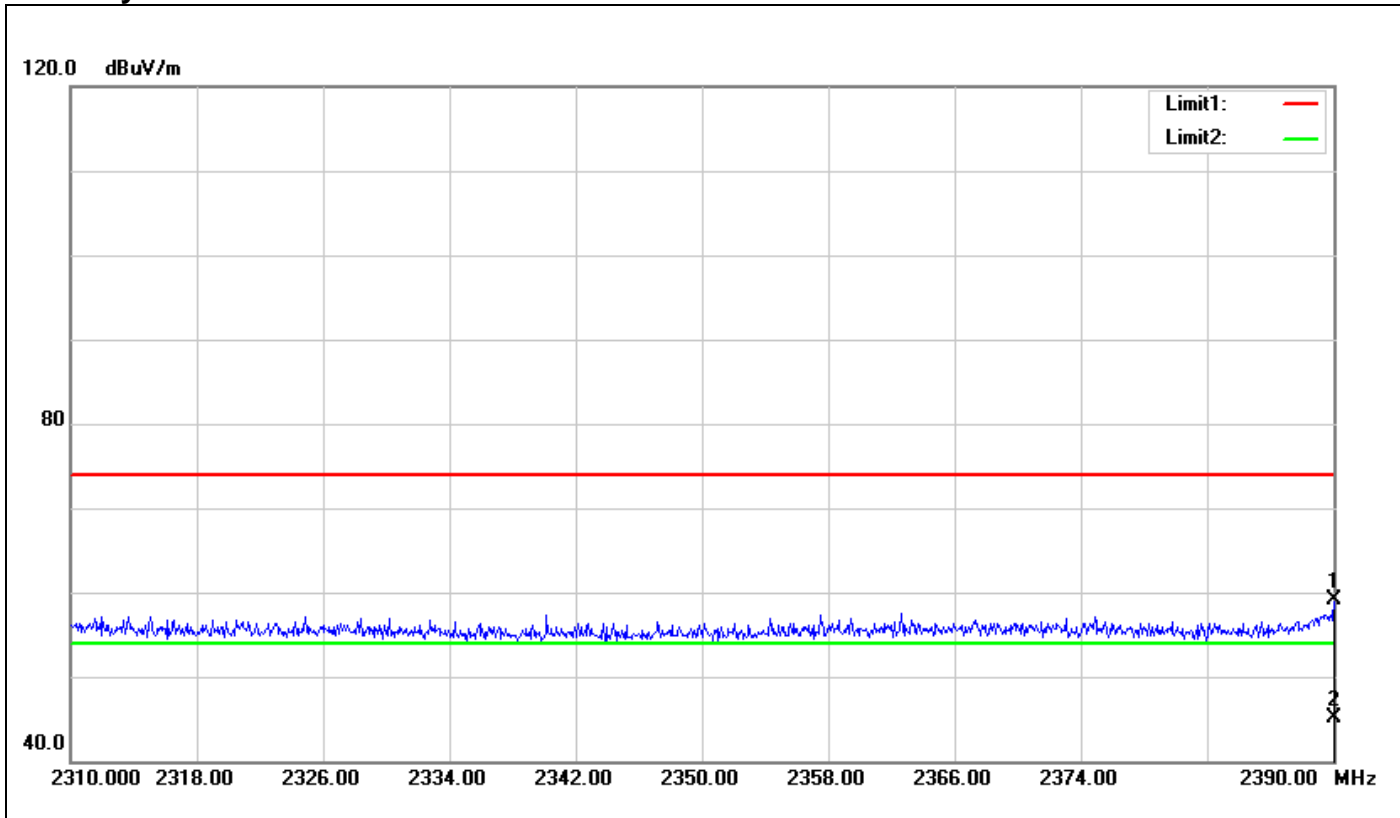

No.	Frequency (MHz)	Reading (dBuV)	Correct Factor(dB/m)	Result (dBuV/m)	Limit (dBuV/m)	Margin (dB)	Height (cm)	Degree ( ° )	Remark
1	2390.000	62.79	-3.77	59.02	74.00	-14.98	100	358	peak
2	2390.000	48.93	-3.77	45.16	54.00	-8.84	100	358	AVG



**Polarity: Horizontal**

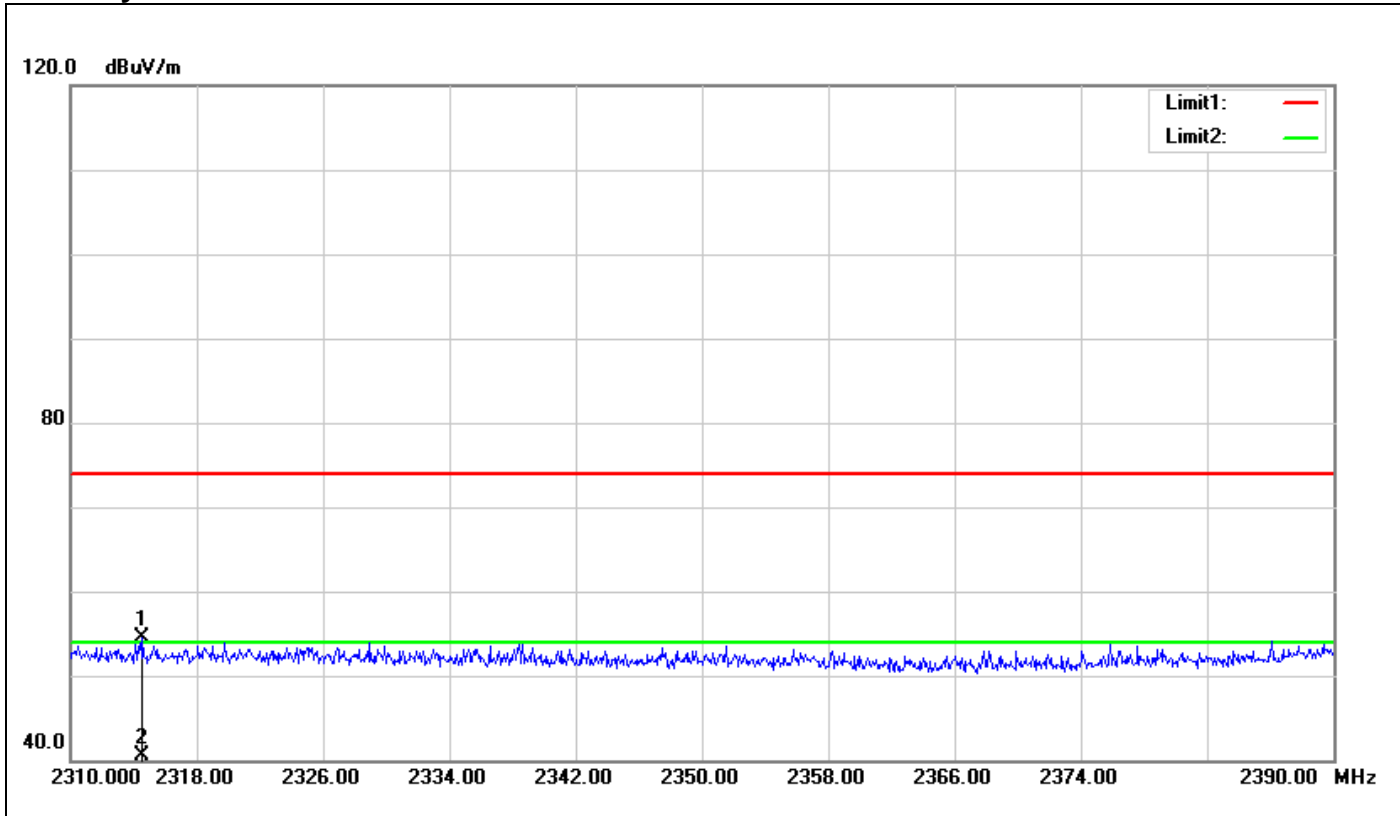

No.	Frequency (MHz)	Reading (dBuV)	Correct Factor(dB/m)	Result (dBuV/m)	Limit (dBuV/m)	Margin (dB)	Height (cm)	Degree (°)	Remark
1	2314.560	58.72	-4.27	54.45	74.00	-19.55	100	270	peak
2	2314.560	44.69	-4.27	40.42	54.00	-13.58	100	270	AVG

**Band Edges (IEEE 802.11b mode / CH High)**

**Polarity: Vertical**

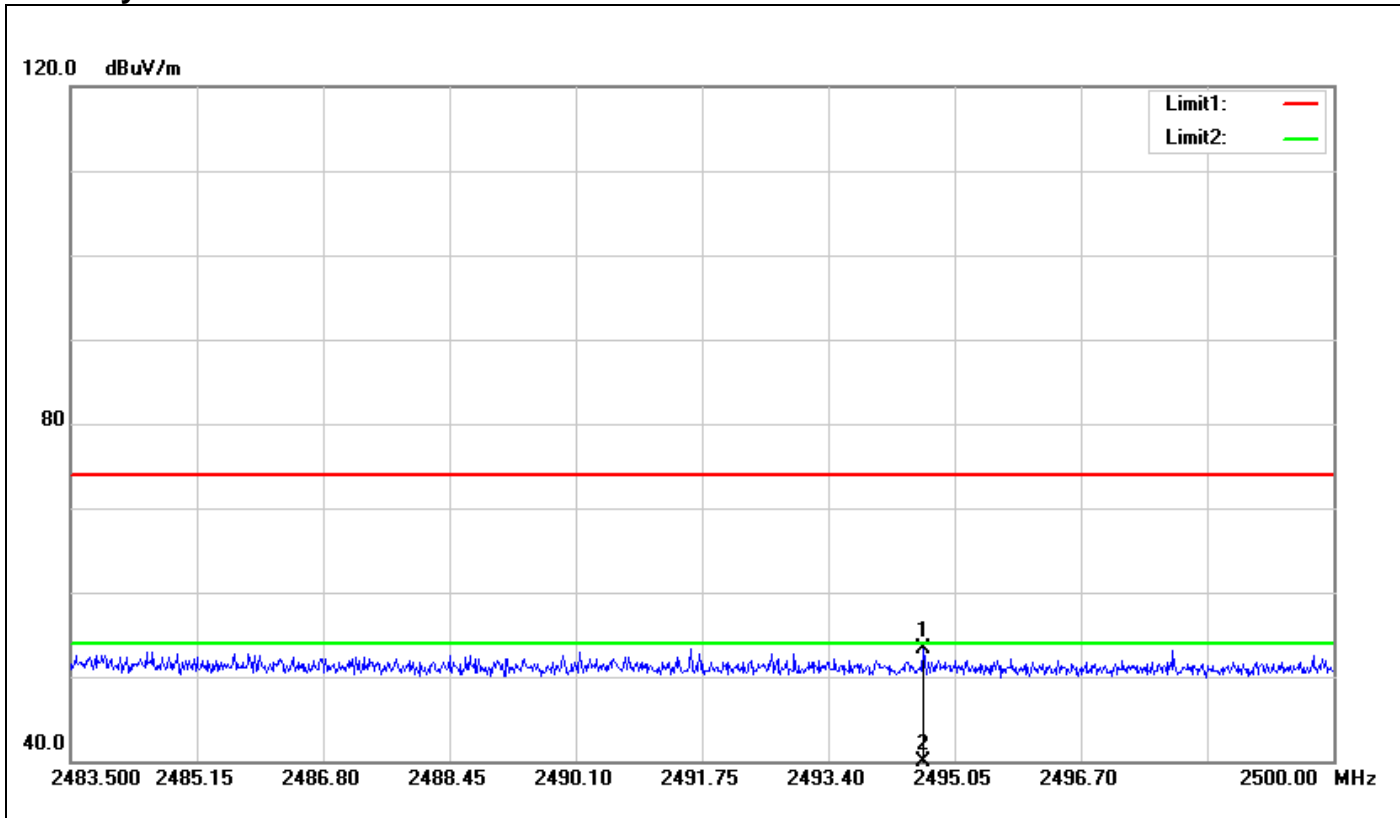

No.	Frequency (MHz)	Reading (dBuV)	Correct Factor(dB/m)	Result (dBuV/m)	Limit (dBuV/m)	Margin (dB)	Height (cm)	Degree (°)	Remark
1	2494.637	56.45	-3.17	53.28	74.00	-20.72	100	140	peak
2	2494.637	42.68	-3.17	39.51	54.00	-14.49	100	140	AVG

**Polarity: Horizontal**

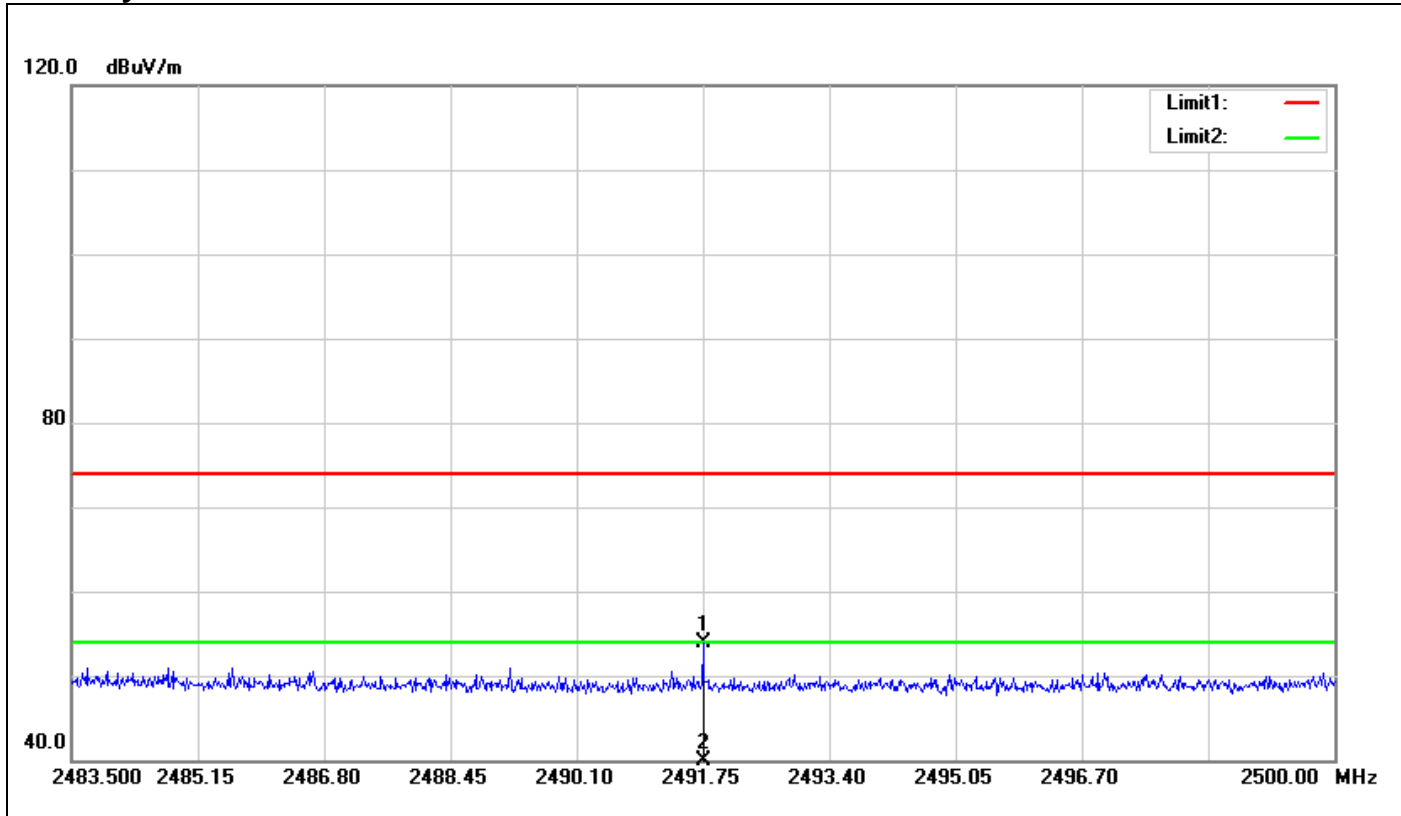

No.	Frequency (MHz)	Reading (dBuV)	Correct Factor(dB/m)	Result (dBuV/m)	Limit (dBuV/m)	Margin (dB)	Height (cm)	Degree (°)	Remark
1	2491.750	57.02	-3.19	53.83	74.00	-20.17	100	301	peak
2	2491.750	40.16	-3.19	36.97	54.00	-17.03	100	301	AVG

**Band Edges (IEEE 802.11g mode / CH Low)**

**Polarity: Vertical**

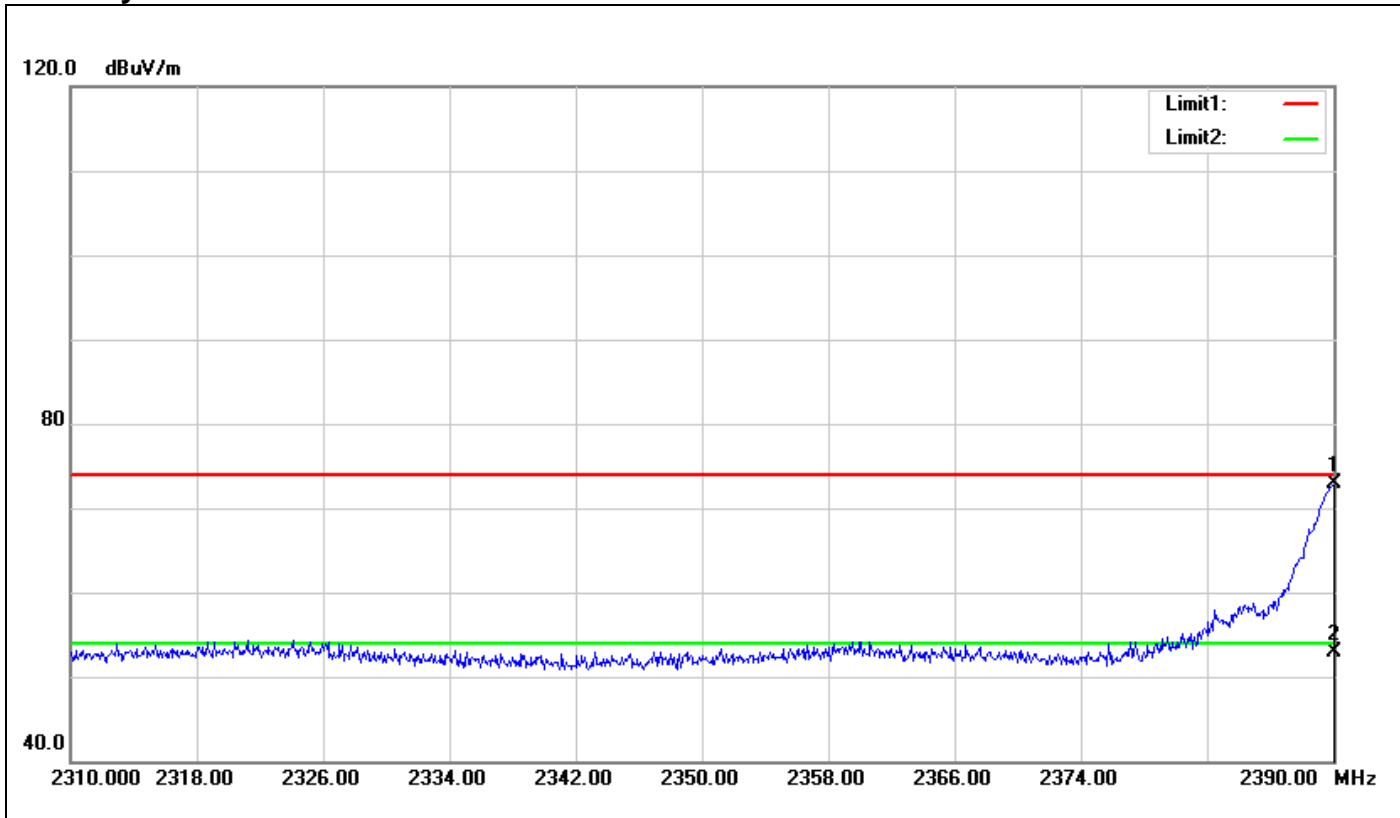

No.	Frequency (MHz)	Reading (dBuV)	Correct Factor(dB/m)	Result (dBuV/m)	Limit (dBuV/m)	Margin (dB)	Height (cm)	Degree (°)	Remark
1	2390.000	76.62	-3.77	72.85	74.00	-1.15	100	0	peak
2	2390.000	56.66	-3.77	52.89	54.00	-1.11	100	0	AVG

**Polarity: Horizontal**

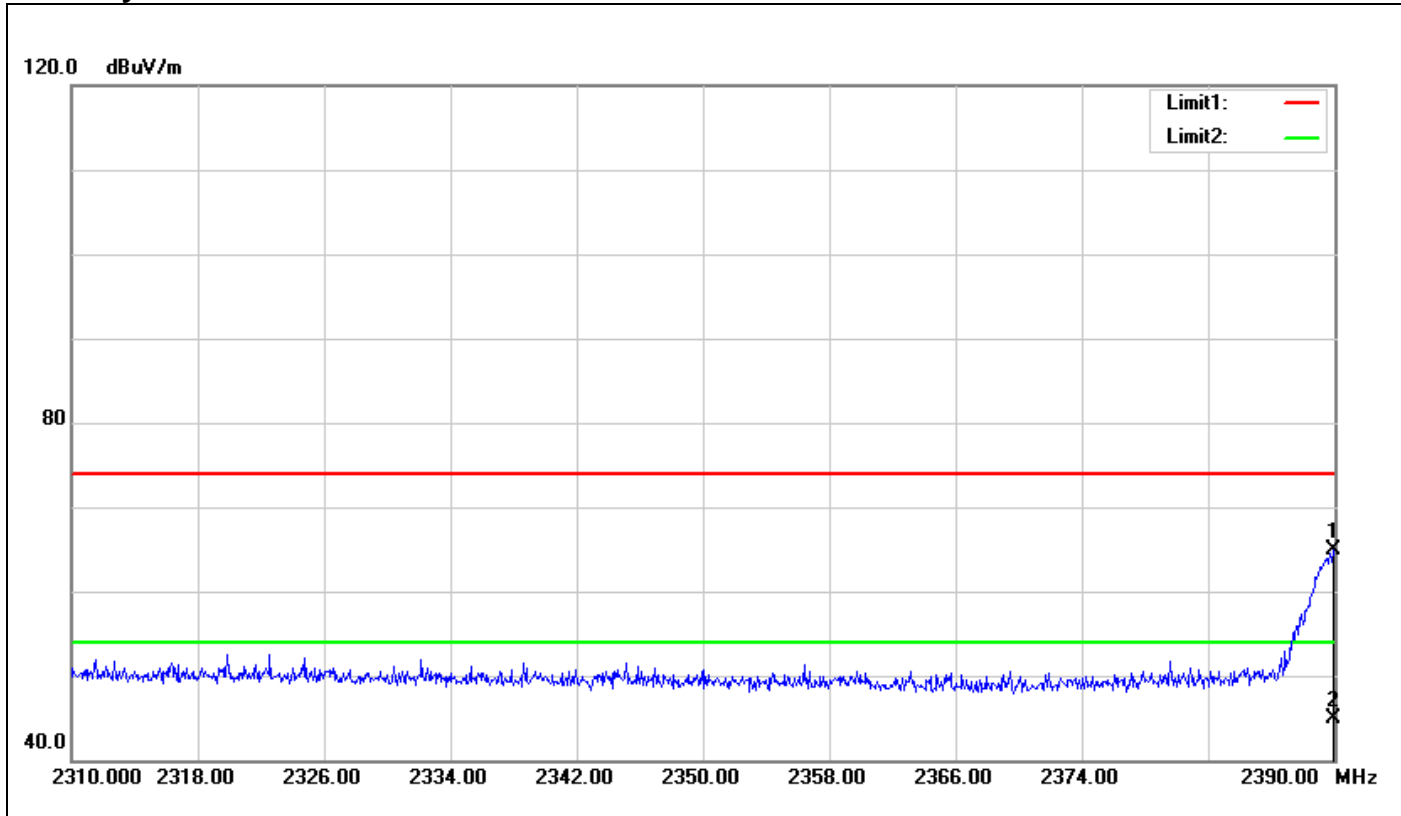

No.	Frequency (MHz)	Reading (dBuV)	Correct Factor(dB/m)	Result (dBuV/m)	Limit (dBuV/m)	Margin (dB)	Height (cm)	Degree (°)	Remark
1	2389.920	68.61	-3.77	64.84	74.00	-9.16	100	5	peak
2	2389.920	48.71	-3.77	44.94	54.00	-9.06	100	5	AVG

**Band Edges (IEEE 802.11g mode / CH High)**

**Polarity: Vertical**

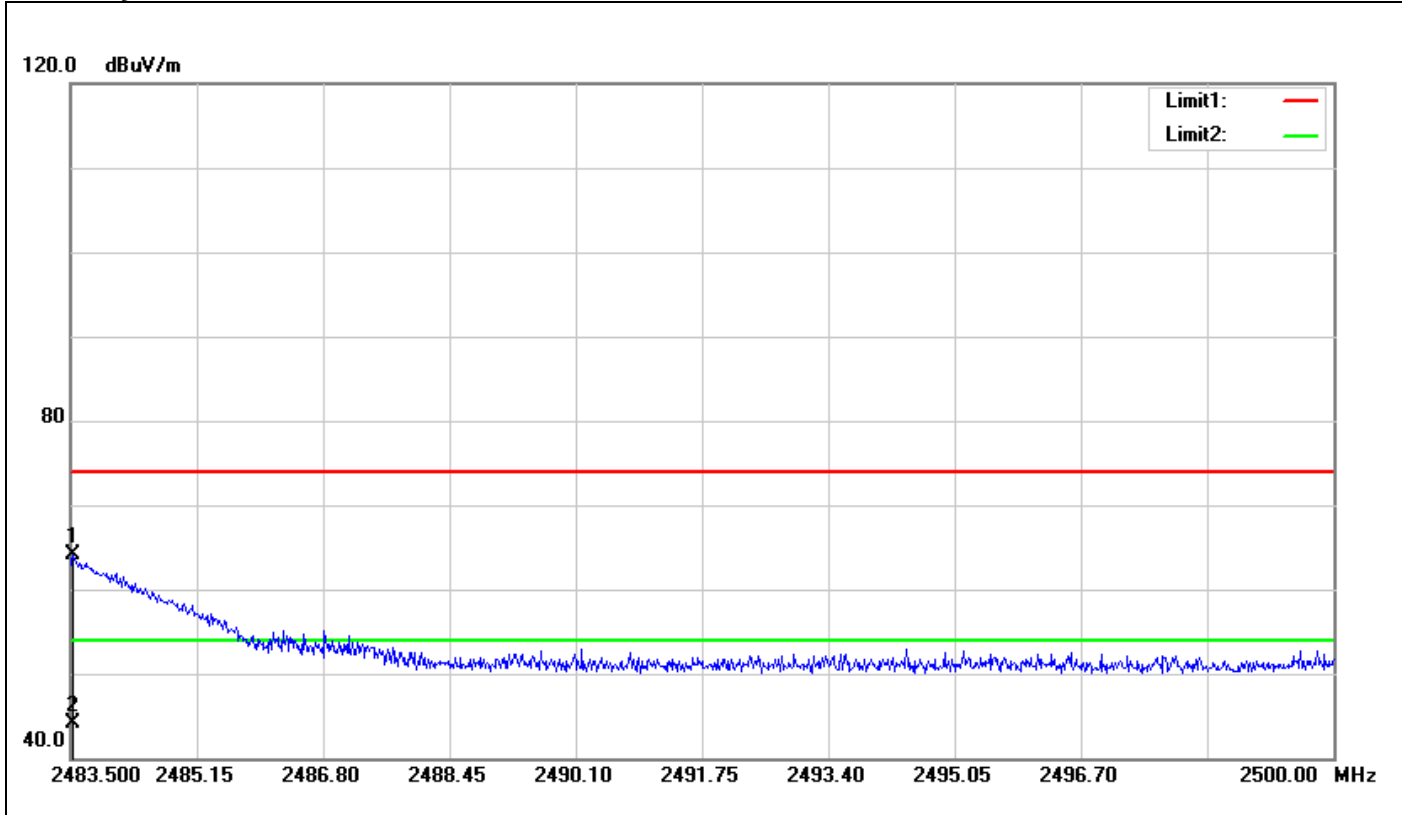

No.	Frequency (MHz)	Reading (dBuV)	Correct Factor(dB/m)	Result (dBuV/m)	Limit (dBuV/m)	Margin (dB)	Height (cm)	Degree (°)	Remark
1	2483.533	67.32	-3.27	64.05	74.00	-9.95	100	49	peak
2	2483.533	47.44	-3.27	44.17	54.00	-9.83	100	49	AVG

**Polarity: Horizontal**

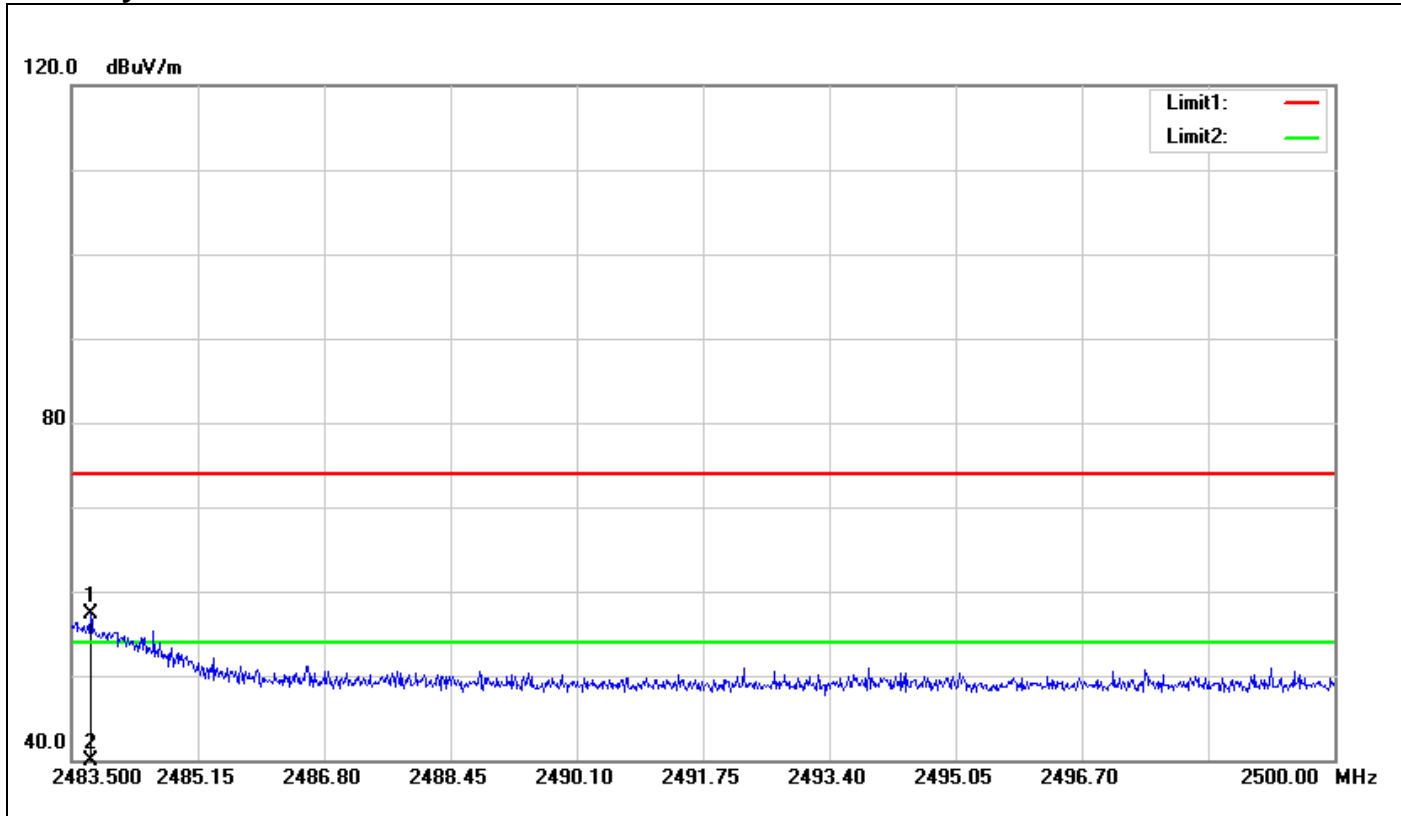

No.	Frequency (MHz)	Reading (dBuV)	Correct Factor(dB/m)	Result (dBuV/m)	Limit (dBuV/m)	Margin (dB)	Height (cm)	Degree (°)	Remark
1	2483.747	60.57	-3.27	57.30	74.00	-16.70	100	200	peak
2	2483.747	42.76	-3.27	39.49	54.00	-14.51	100	200	AVG

**Band Edges (IEEE 802.11n HT 20 mode / CH Low)**

**Polarity: Vertical**

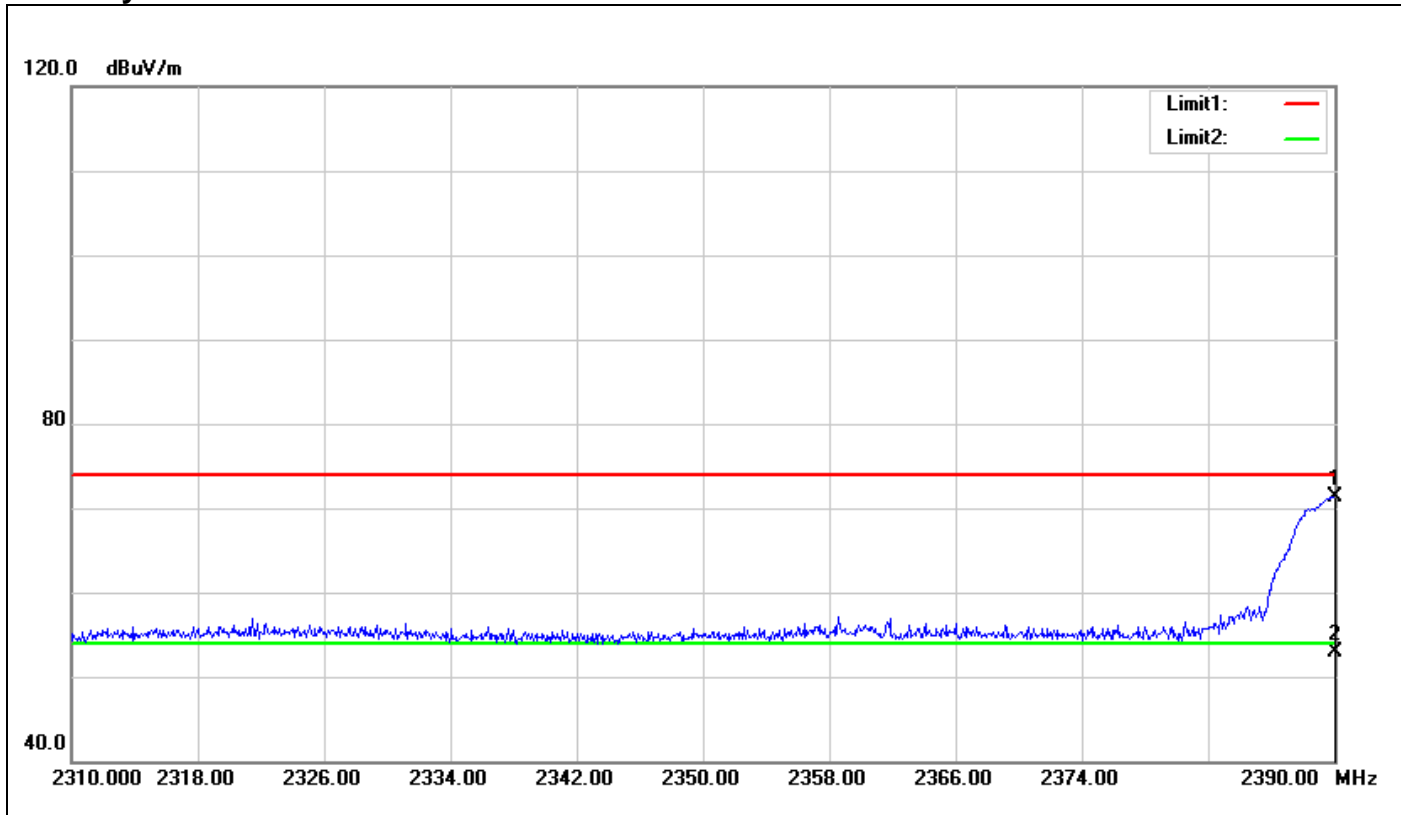

No.	Frequency (MHz)	Reading (dBuV)	Correct Factor(dB/m)	Result (dBuV/m)	Limit (dBuV/m)	Margin (dB)	Height (cm)	Degree (°)	Remark
1	2390.000	75.16	-3.77	71.39	74.00	-2.61	100	113	peak
2	2390.000	56.70	-3.77	52.93	54.00	-1.07	100	113	AVG



**Polarity: Horizontal**

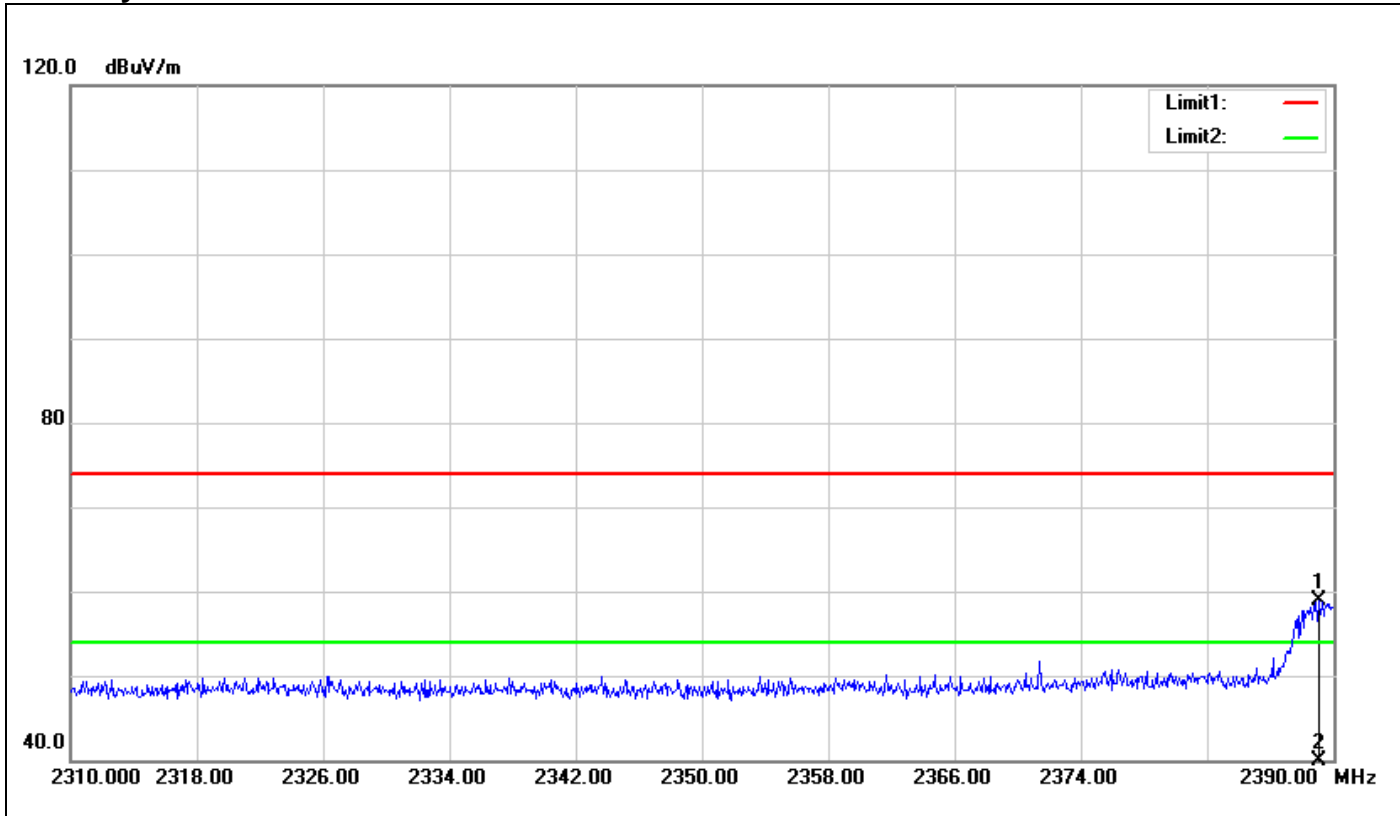

No.	Frequency (MHz)	Reading (dBuV)	Correct Factor(dB/m)	Result (dBuV/m)	Limit (dBuV/m)	Margin (dB)	Height (cm)	Degree (°)	Remark
1	2389.040	62.74	-3.78	58.96	74.00	-15.04	100	248	peak
2	2389.040	43.54	-3.78	39.76	54.00	-14.24	100	248	AVG

**Band Edges (IEEE 802.11n HT 20 mode / CH High)**

**Polarity: Vertical**

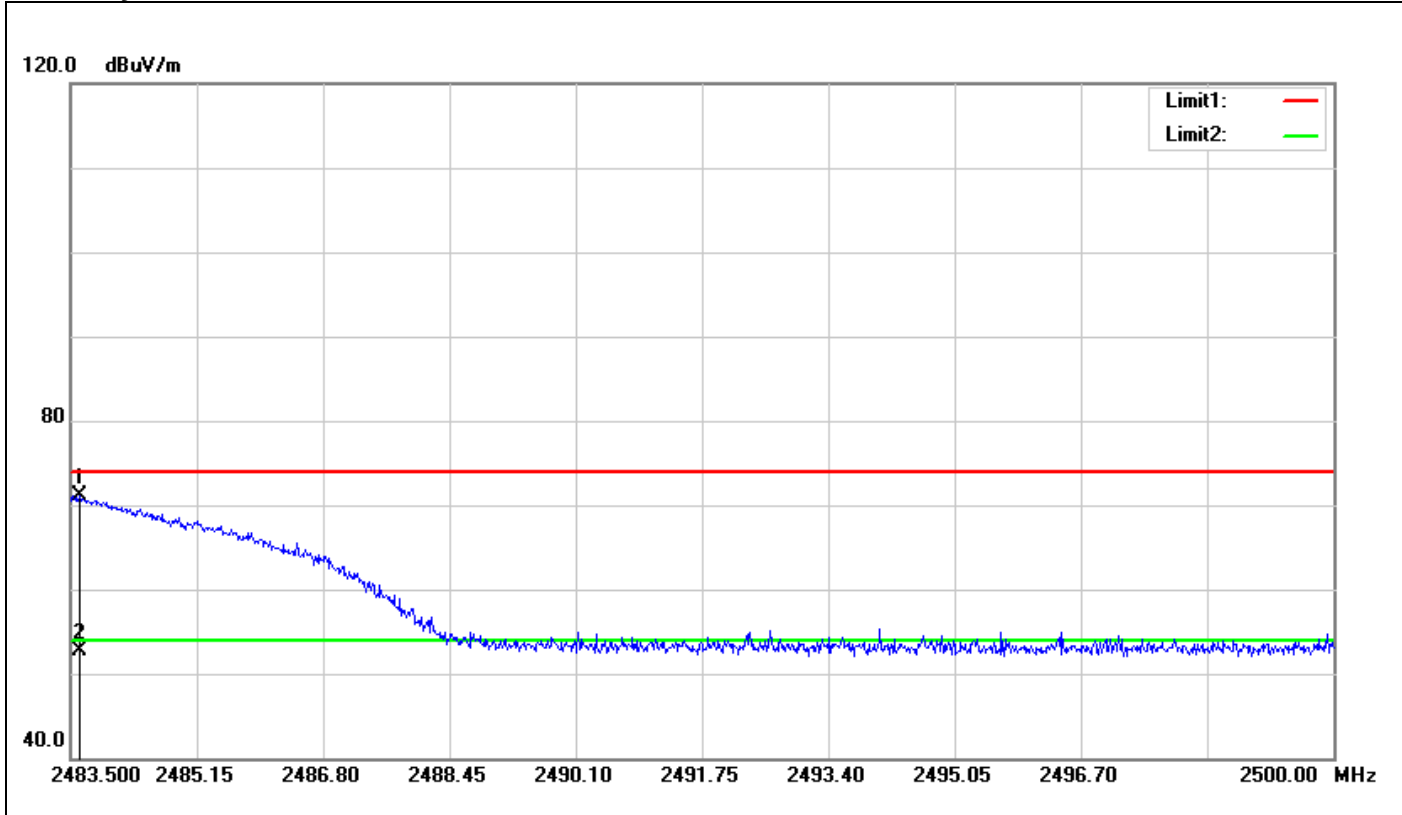

No.	Frequency (MHz)	Reading (dBuV)	Correct Factor(dB/m)	Result (dBuV/m)	Limit (dBuV/m)	Margin (dB)	Height (cm)	Degree (°)	Remark
1	2483.615	74.42	-3.27	71.15	74.00	-2.85	100	248	peak
2	2483.615	55.95	-3.27	52.68	54.00	-1.32	100	248	AVG

**Polarity: Horizontal**

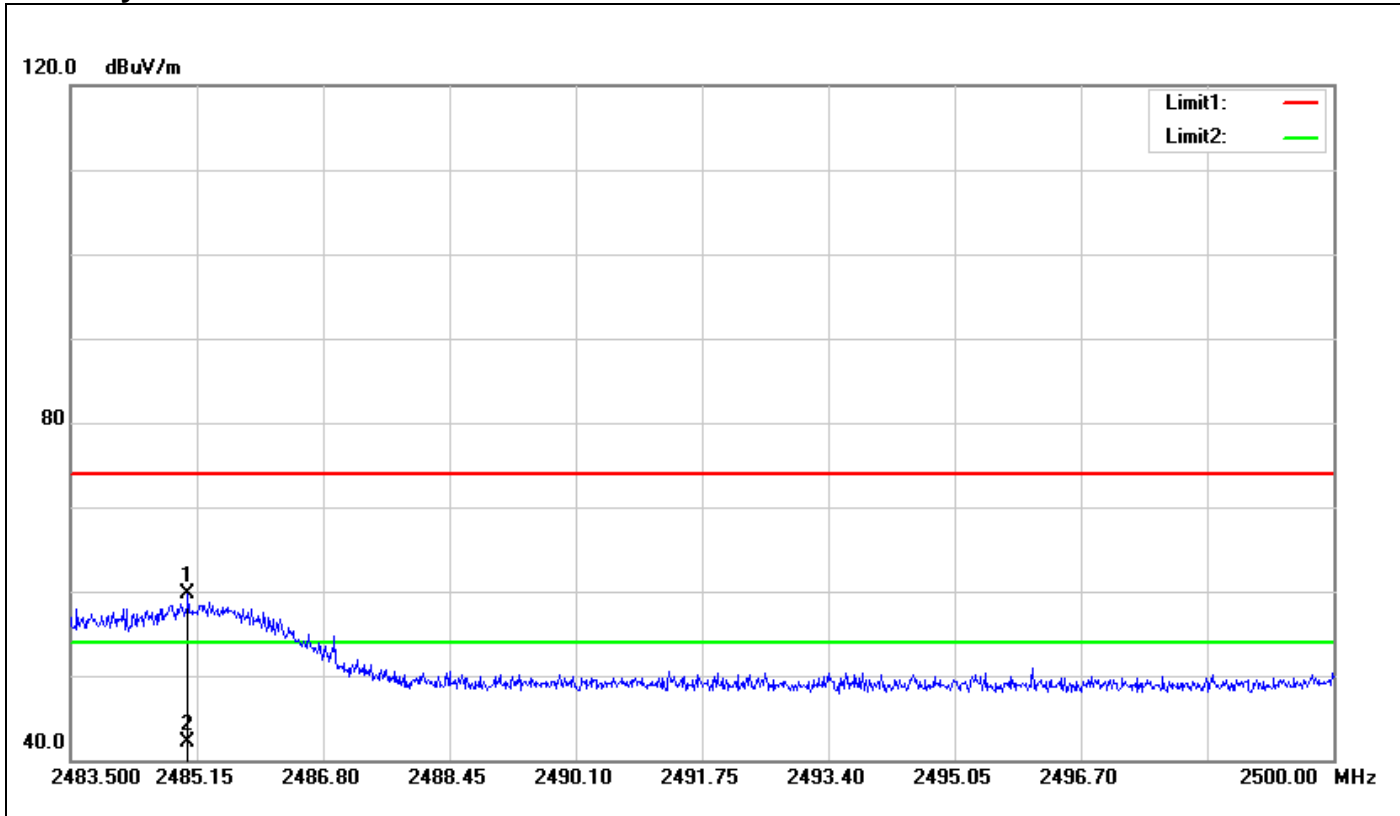

No.	Frequency (MHz)	Reading (dBuV)	Correct Factor(dB/m)	Result (dBuV/m)	Limit (dBuV/m)	Margin (dB)	Height (cm)	Degree (°)	Remark
1	2485.035	63.05	-3.26	59.79	74.00	-14.21	100	240	peak
2	2485.035	45.28	-3.26	42.02	54.00	-11.98	100	240	AVG

**Band Edges (IEEE 802.11n HT 40 mode / CH Low)**

**Polarity: Vertical**

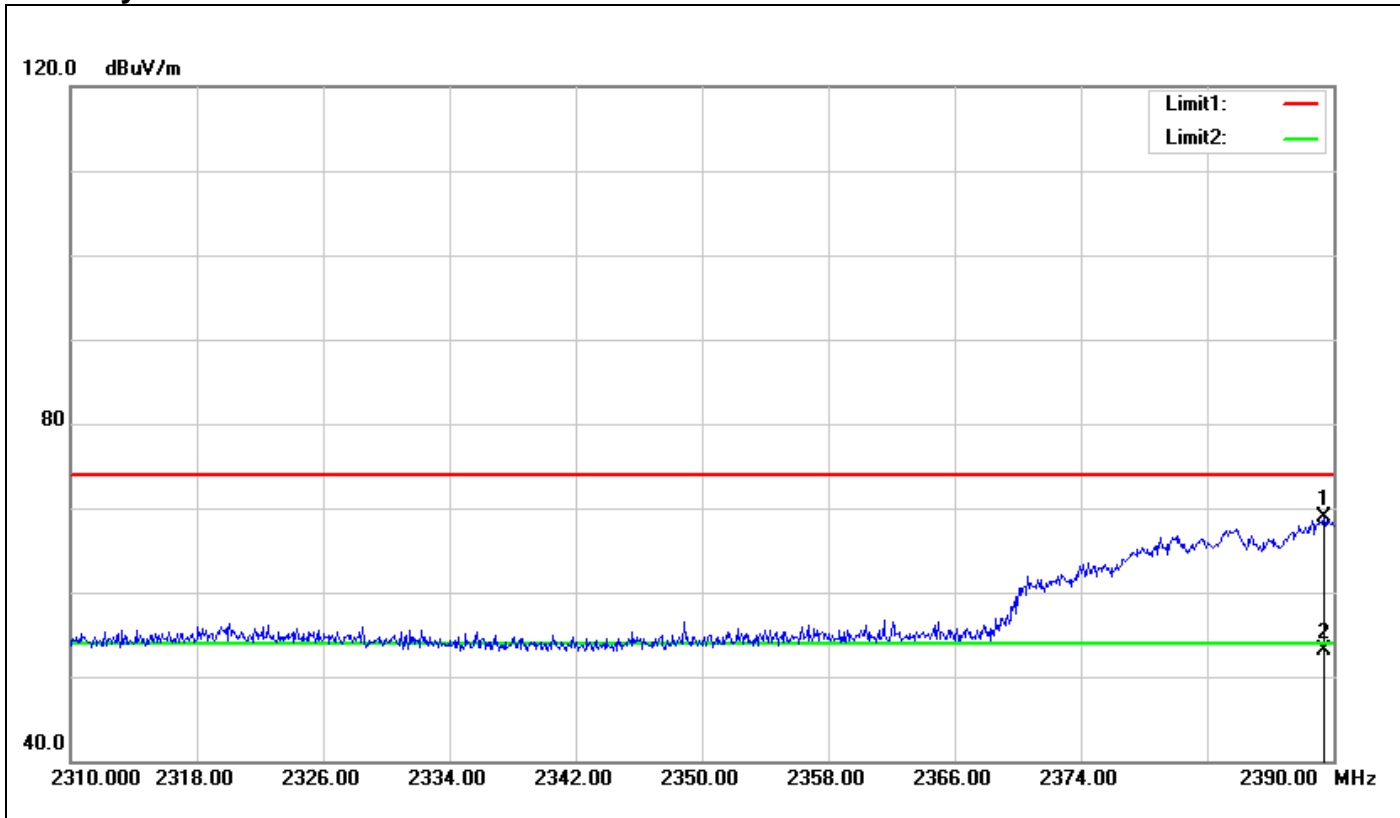

No.	Frequency (MHz)	Reading (dBuV)	Correct Factor(dB/m)	Result (dBuV/m)	Limit (dBuV/m)	Margin (dB)	Height (cm)	Degree (°)	Remark
1	2389.440	72.71	-3.78	68.93	74.00	-5.07	100	1	peak
2	2389.440	56.79	-3.78	53.01	54.00	-0.99	100	1	AVG

**Polarity: Horizontal**

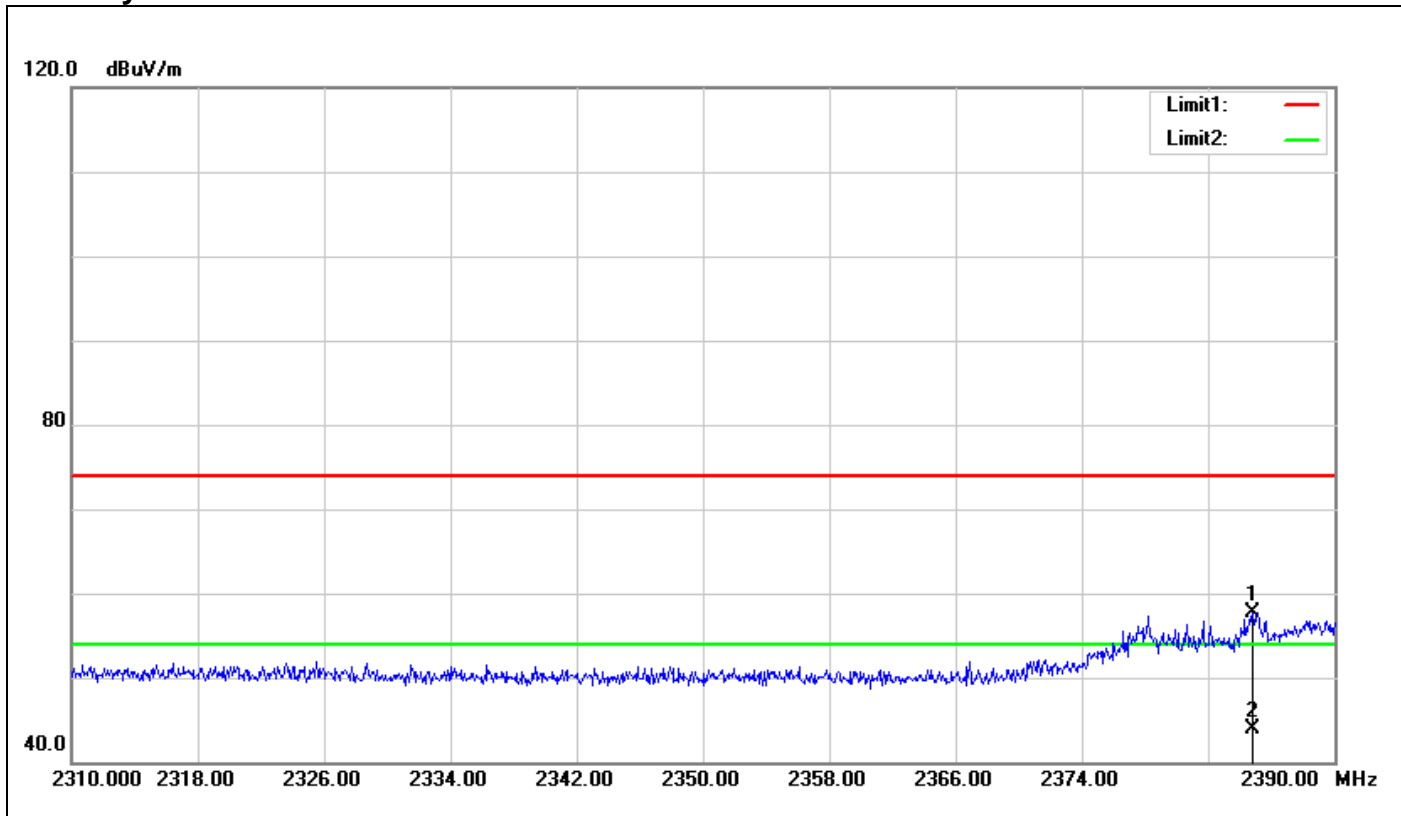

No.	Frequency (MHz)	Reading (dBuV)	Correct Factor(dB/m)	Result (dBuV/m)	Limit (dBuV/m)	Margin (dB)	Height (cm)	Degree (°)	Remark
1	2384.800	61.60	-3.82	57.78	74.00	-16.22	100	348	peak
2	2384.800	47.79	-3.82	43.97	54.00	-10.03	100	348	AVG

**Band Edges (IEEE 802.11n HT 40 mode / CH High)**

**Polarity: Vertical**

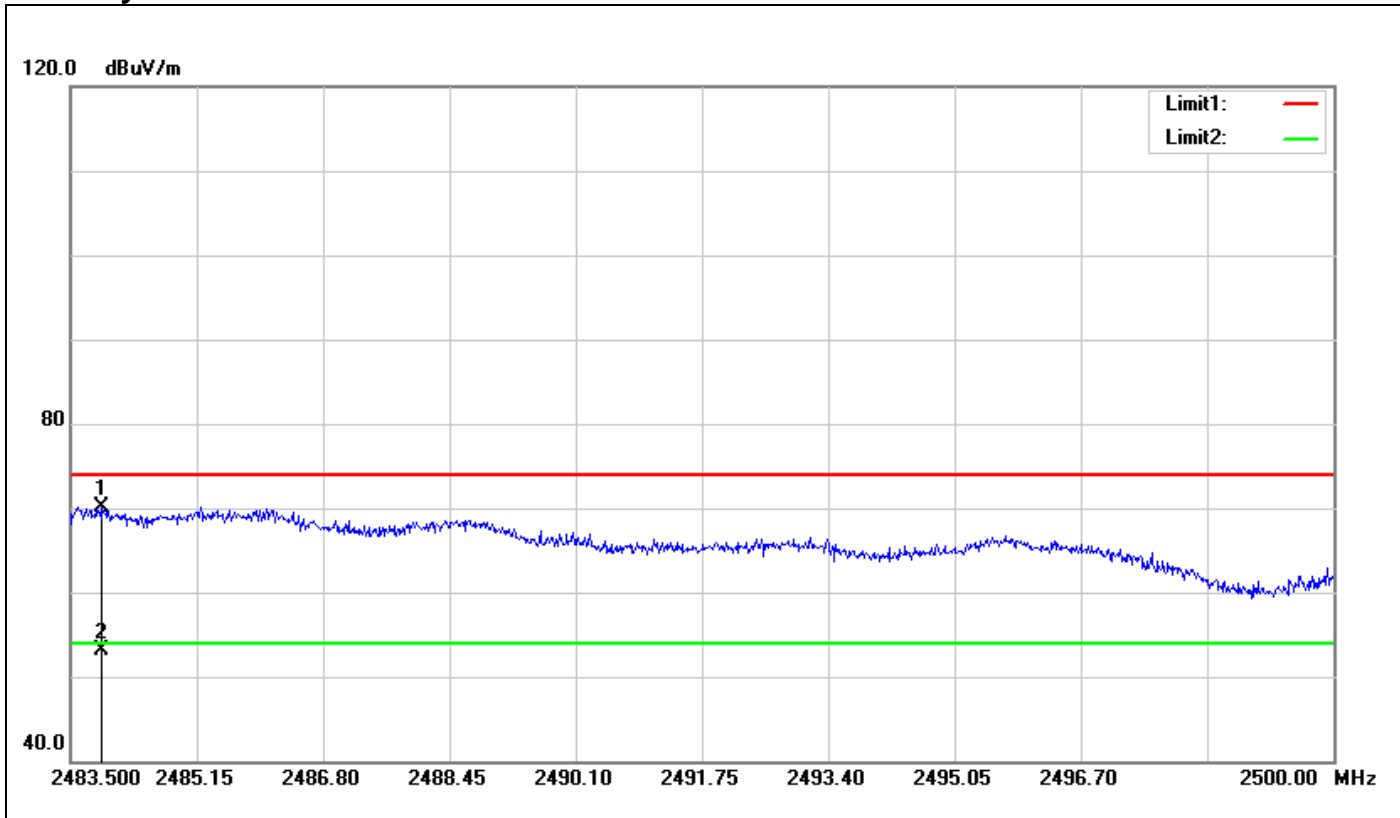

No.	Frequency (MHz)	Reading (dBuV)	Correct Factor(dB/m)	Result (dBuV/m)	Limit (dBuV/m)	Margin (dB)	Height (cm)	Degree (°)	Remark
1	2483.912	73.37	-3.27	70.10	74.00	-3.90	100	100	peak
2	2483.912	56.39	-3.27	53.12	54.00	-0.88	100	100	AVG

**Polarity: Horizontal**

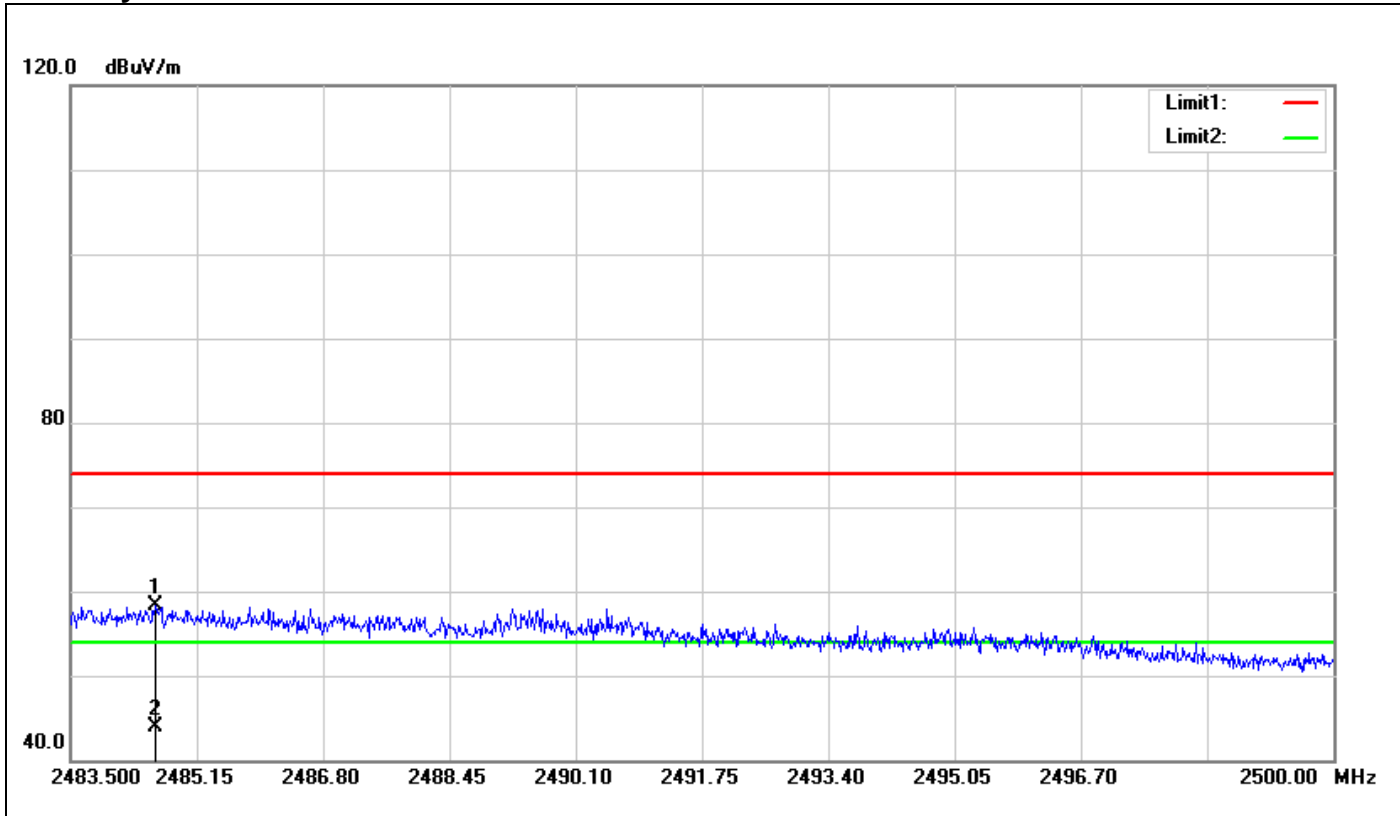

No.	Frequency (MHz)	Reading (dBuV)	Correct Factor(dB/m)	Result (dBuV/m)	Limit (dBuV/m)	Margin (dB)	Height (cm)	Degree (°)	Remark
1	2484.606	61.57	-3.26	58.31	74.00	-15.69	100	31	peak
2	2484.606	47.14	-3.26	43.88	54.00	-10.12	100	31	AVG

**Test Plot**

**Conducted Band Edges (IEEE 802.11b mode / CH Low)**

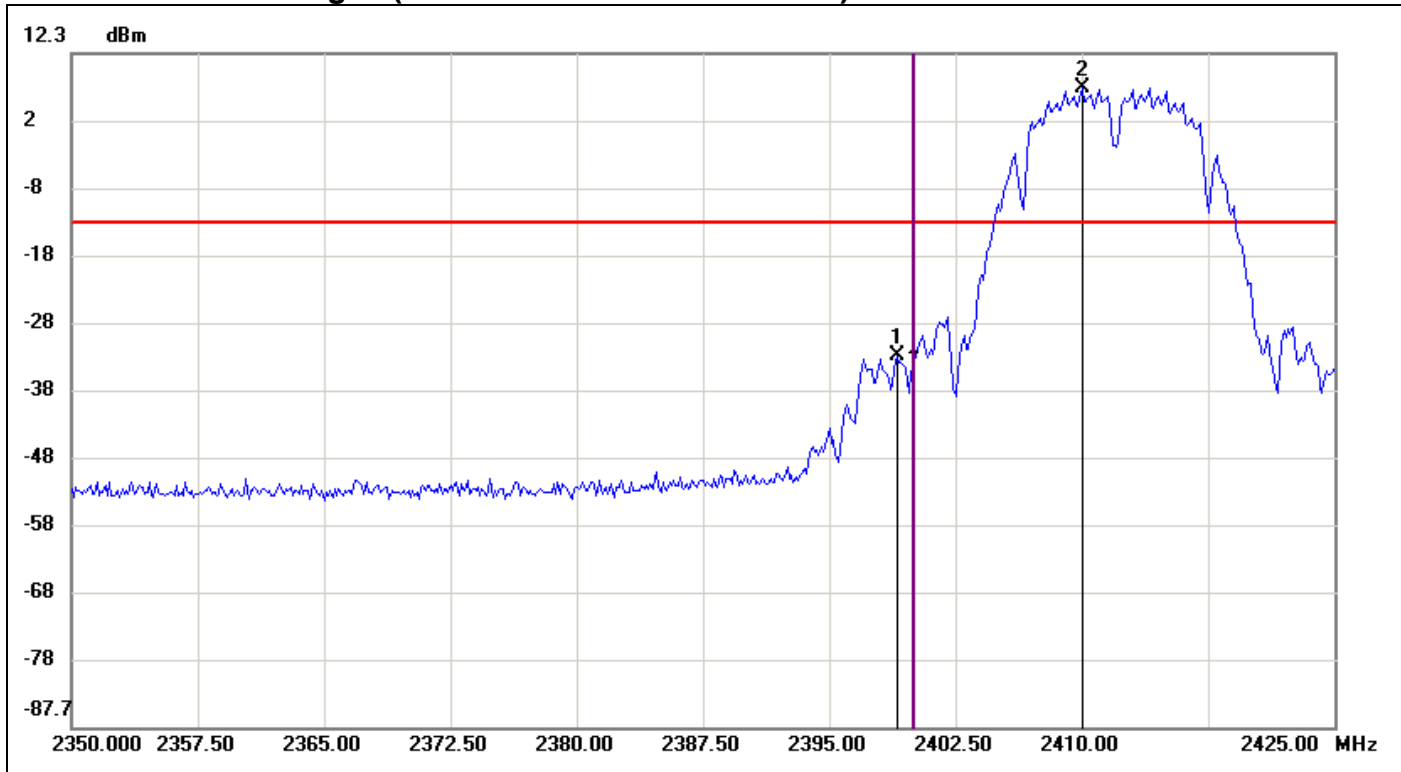

No.	Frequency(MHz)	Result(dBm)	Limit(dBm)	Margin(dBm)
1	2399.0000	-32.63	-12.85	-19.78
2	2410.0000	7.15	-12.85	20.00



**Conducted Band Edges (IEEE 802.11b mode / CH High)**

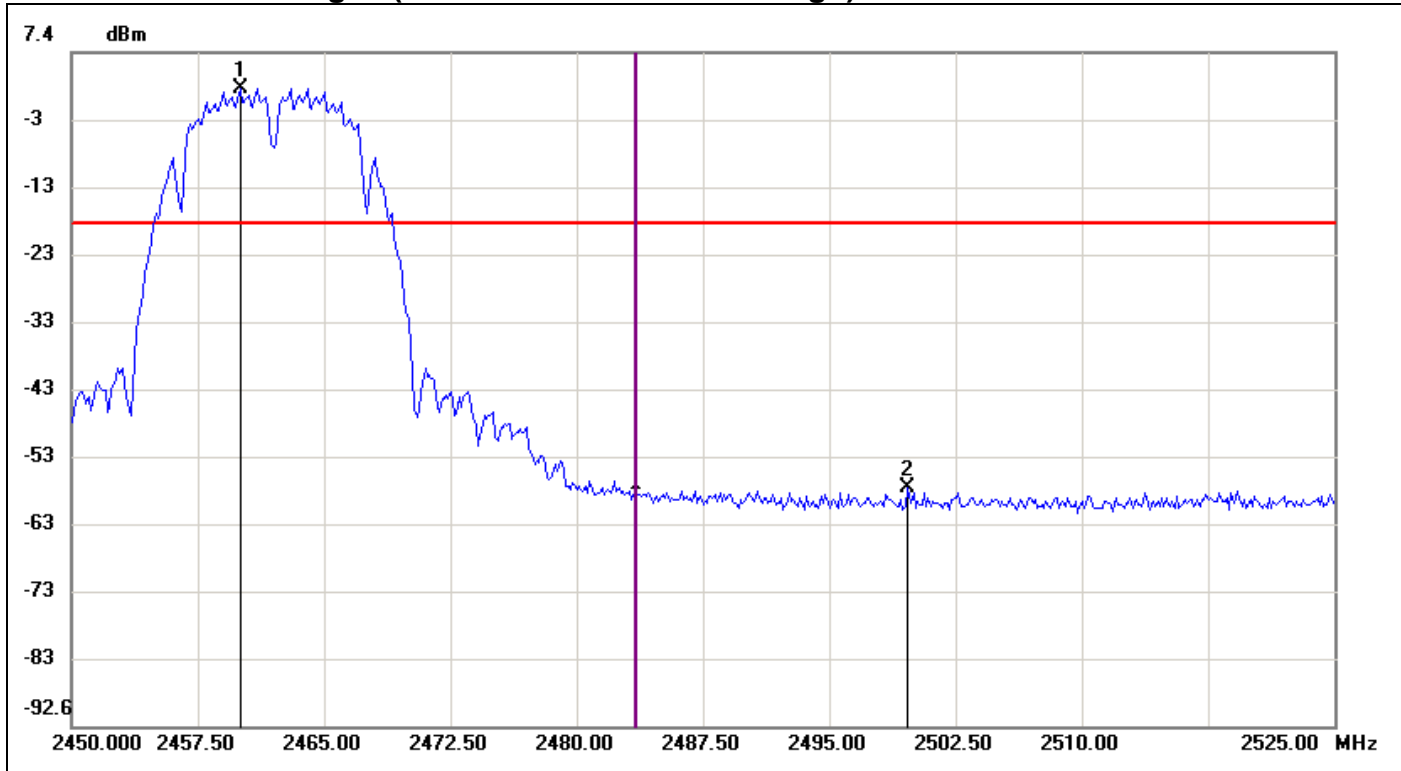

No.	Frequency(MHz)	Result(dBm)	Limit(dBm)	Margin(dBm)
1	2460.0000	2.04	-17.96	20.00
2	2499.6250	-57.13	-17.96	-39.17

**Conducted Band Edges (IEEE 802.11g mode / CH Low)**

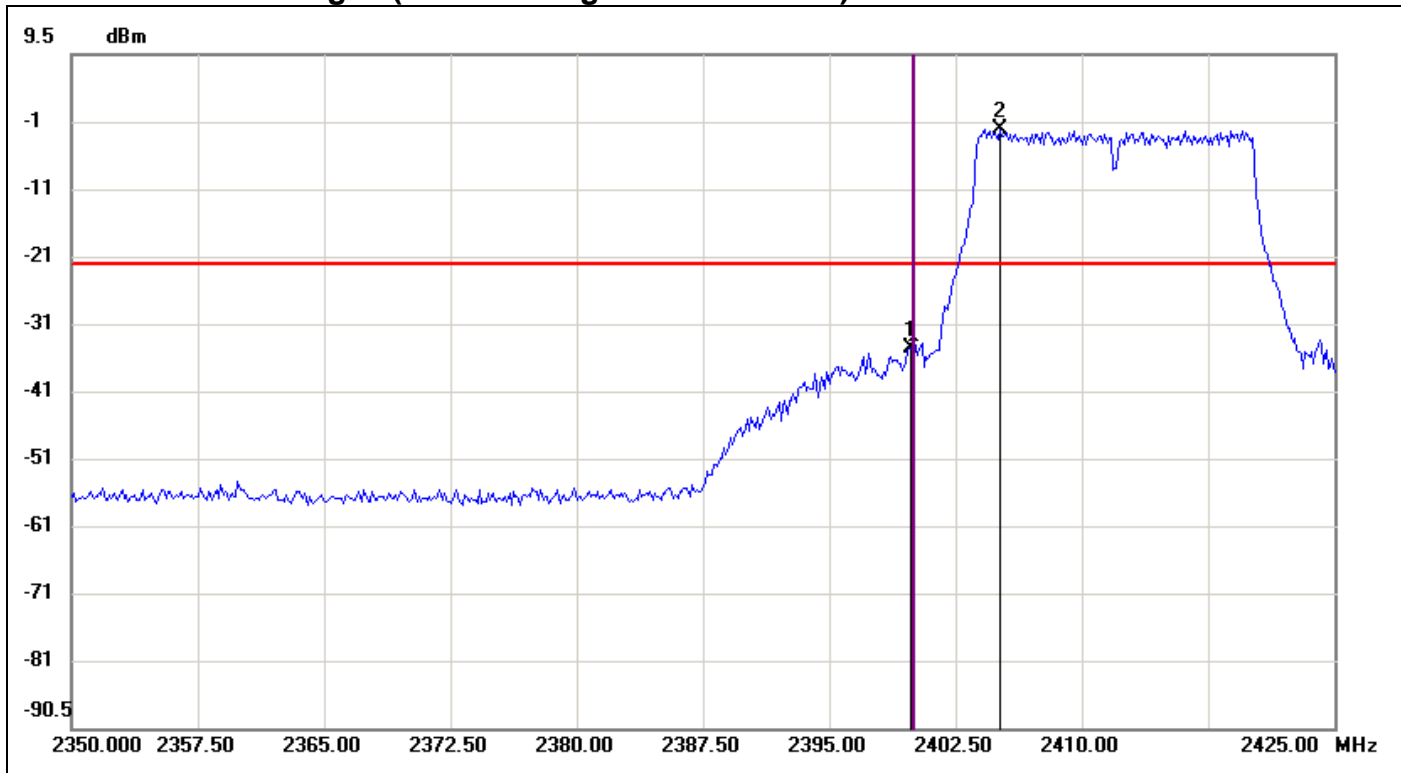

No.	Frequency(MHz)	Result(dBm)	Limit(dBm)	Margin(dBm)
1	2399.8750	-34.02	-21.62	-12.40
2	2405.1250	-1.62	-21.62	20.00

**Conducted Band Edges (IEEE 802.11g mode / CH High)**

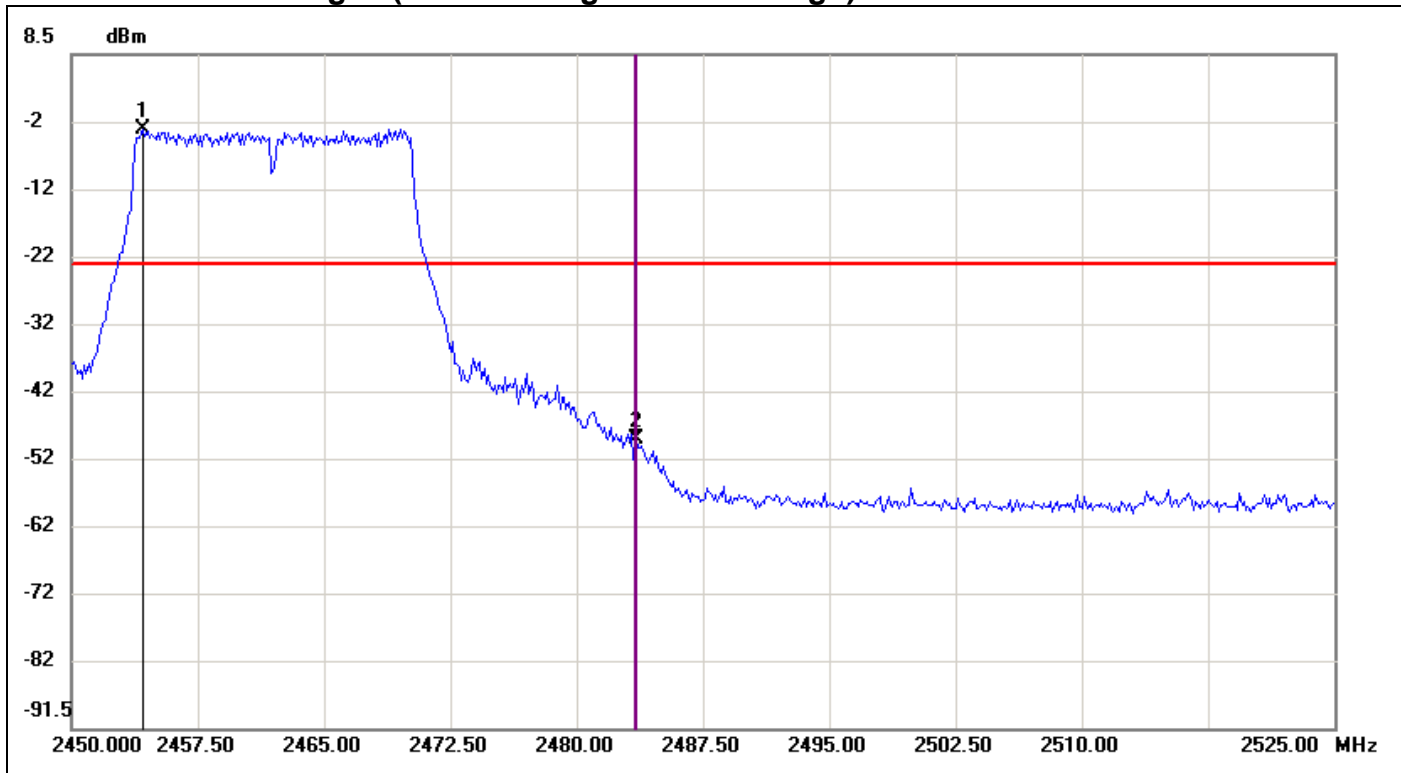

No.	Frequency(MHz)	Result(dBm)	Limit(dBm)	Margin(dBm)
1	2454.2500	-2.62	-22.62	20.00
2	2483.5000	-48.70	-22.62	-26.08

**Conducted Band Edges (IEEE 802.11n HT 20 mode / CH Low / Chain 0)**

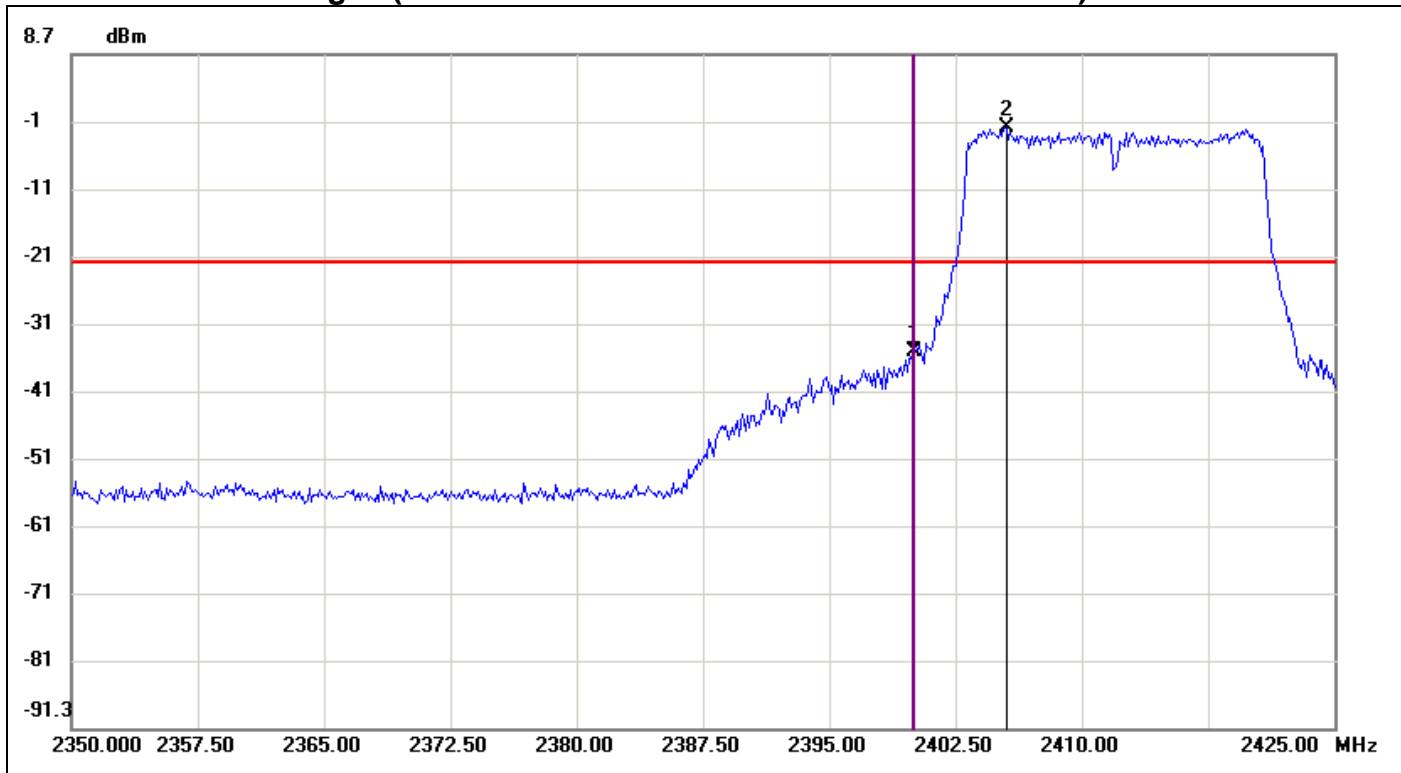

No.	Frequency(MHz)	Result(dBm)	Limit(dBm)	Margin(dBm)
1	2400.0000	-35.38	-22.27	-13.11
2	2405.5000	-2.27	-22.27	20.00

**Conducted Band Edges (IEEE 802.11n HT 20 mode / CH High / Chain 0)**

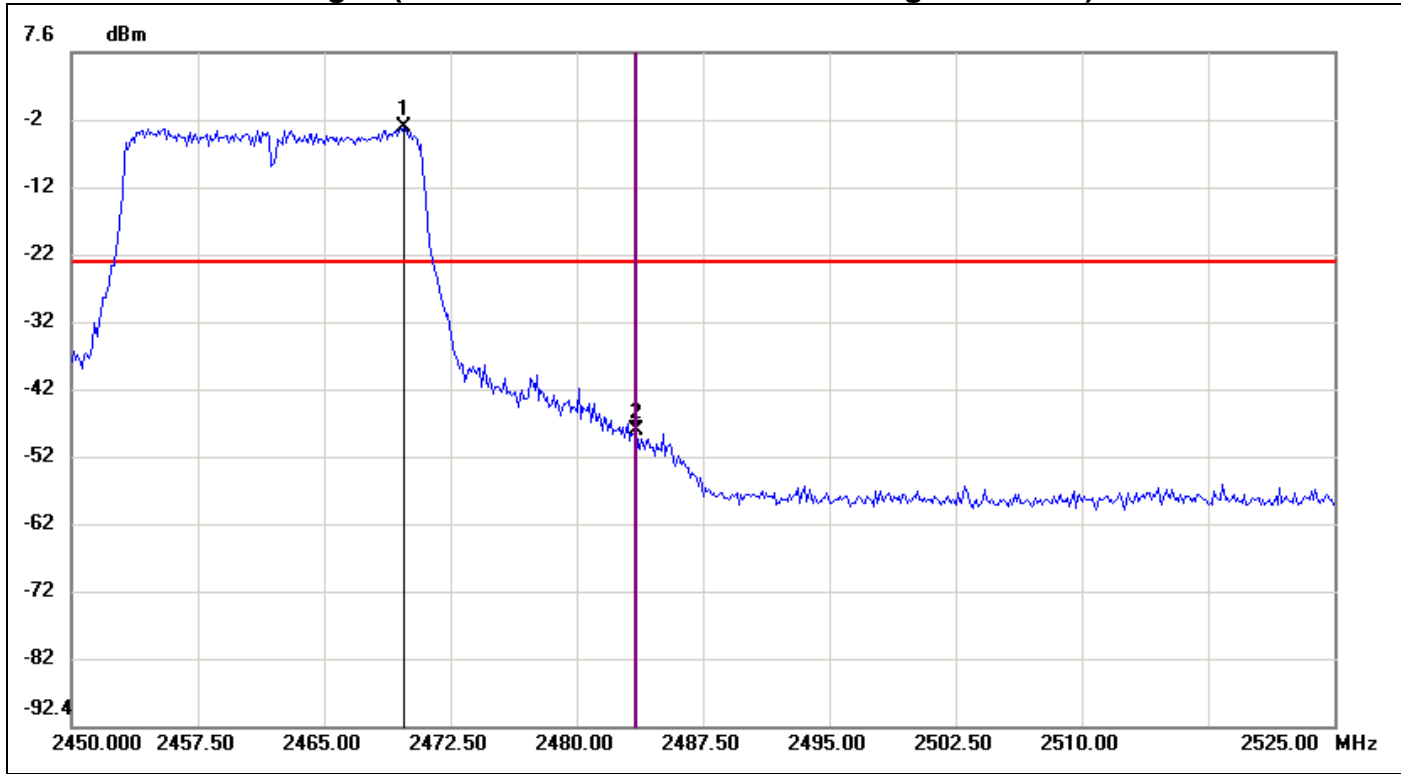

No.	Frequency(MHz)	Result(dBm)	Limit(dBm)	Margin(dBm)
1	2469.7500	-3.49	-23.49	20.00
2	2483.5000	-48.56	-23.49	-25.07

**Conducted Band Edges (IEEE 802.11n HT 20 mode / CH Low / Chain 1)**

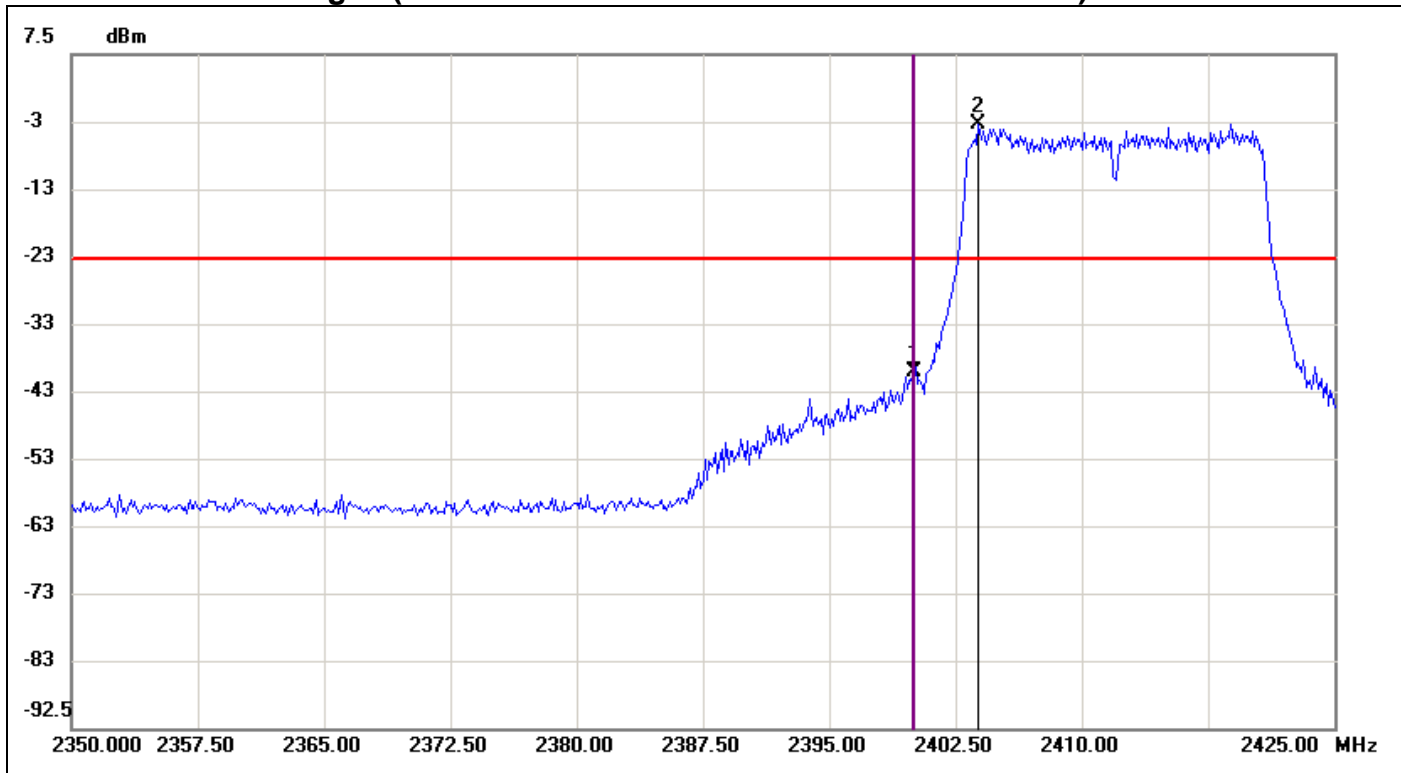

No.	Frequency(MHz)	Result(dBm)	Limit(dBm)	Margin(dBm)
1	2400.0000	-39.67	-22.90	-16.77
2	2403.8750	-2.90	-22.90	20.00

**Conducted Band Edges (IEEE 802.11n HT 20 mode / CH High / Chain 1)**

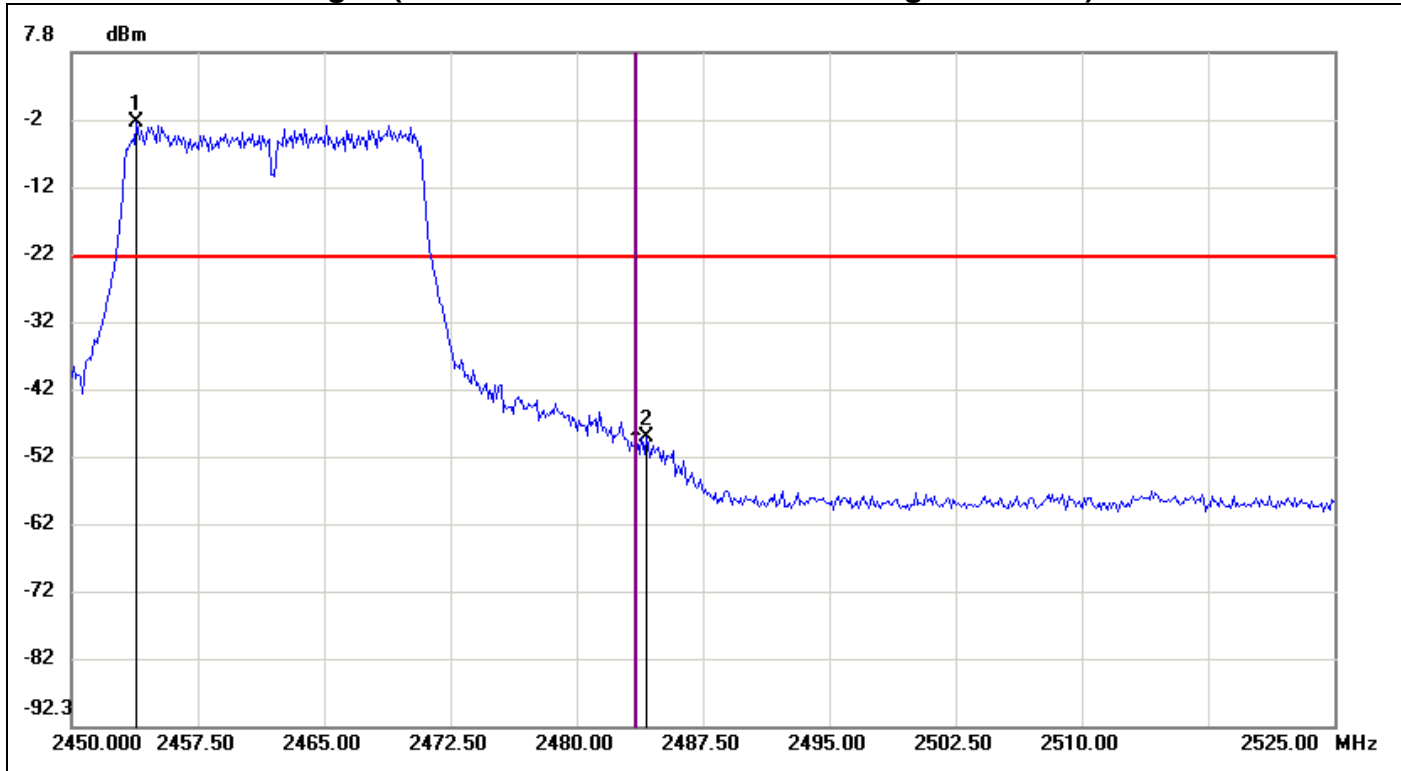

No.	Frequency(MHz)	Result(dBm)	Limit(dBm)	Margin(dBm)
1	2453.8750	-2.70	-22.70	20.00
2	2484.1250	-49.30	-22.70	-26.60

**Conducted Band Edges (IEEE 802.11n HT 40 mode / CH Low / Chain 0)**

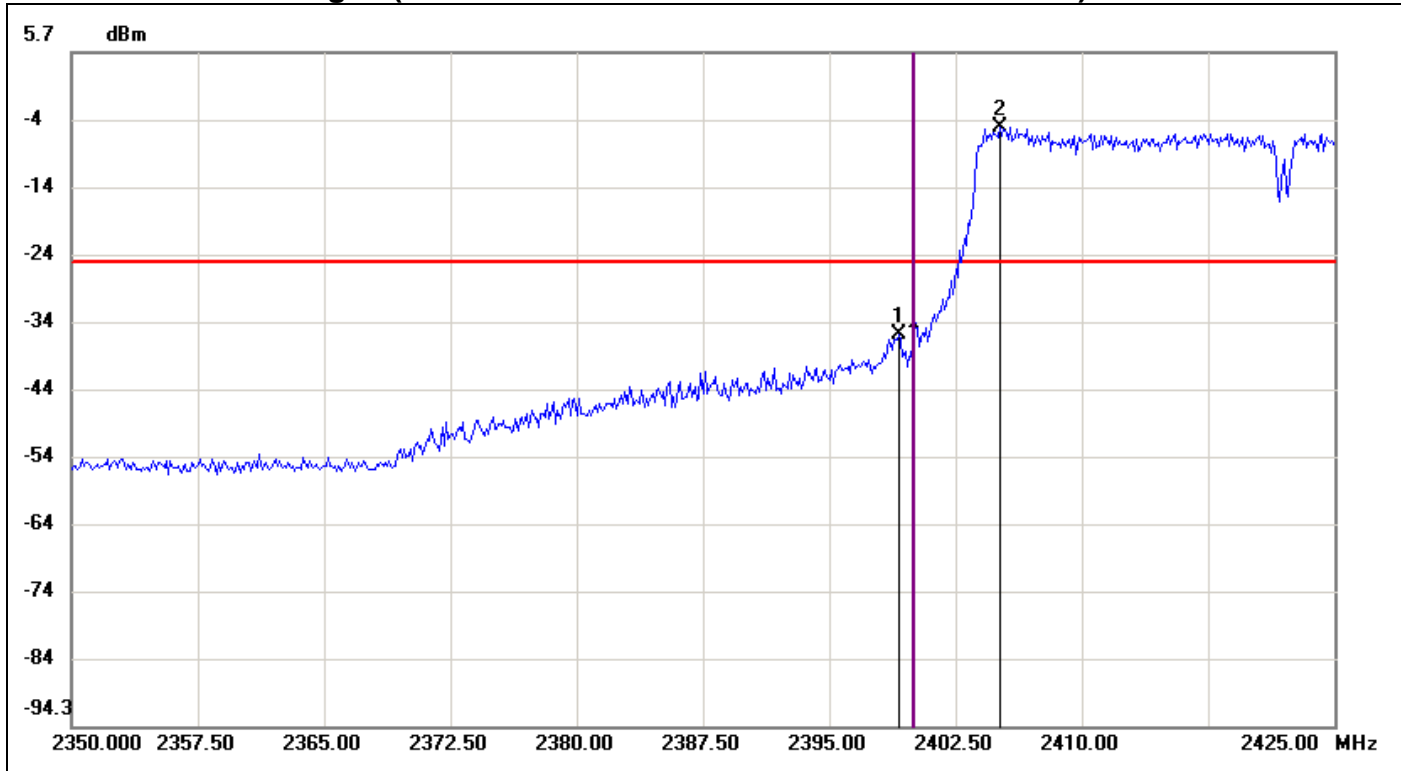

No.	Frequency(MHz)	Result(dBm)	Limit(dBm)	Margin(dBm)
1	2399.1250	-36.16	-25.39	-10.77
2	2405.1250	-5.39	-25.39	20.00



**Conducted Band Edges (IEEE 802.11n HT 40 mode / CH High / Chain 0)**

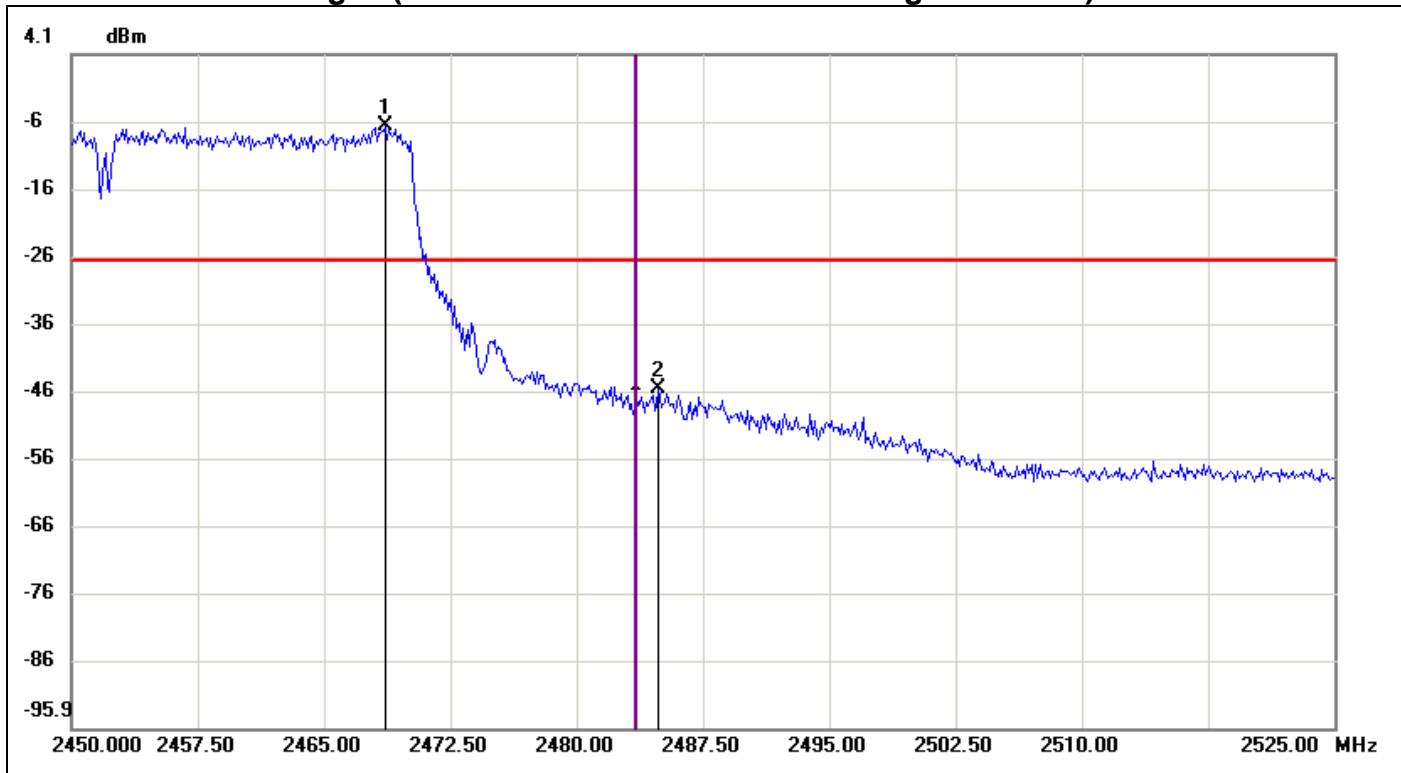

No.	Frequency(MHz)	Result(dBm)	Limit(dBm)	Margin(dBm)
1	2468.6250	-6.57	-26.57	20.00
2	2484.8750	-45.44	-26.57	-18.87

**Conducted Band Edges (IEEE 802.11n HT 40 mode / CH Low / Chain 1)**

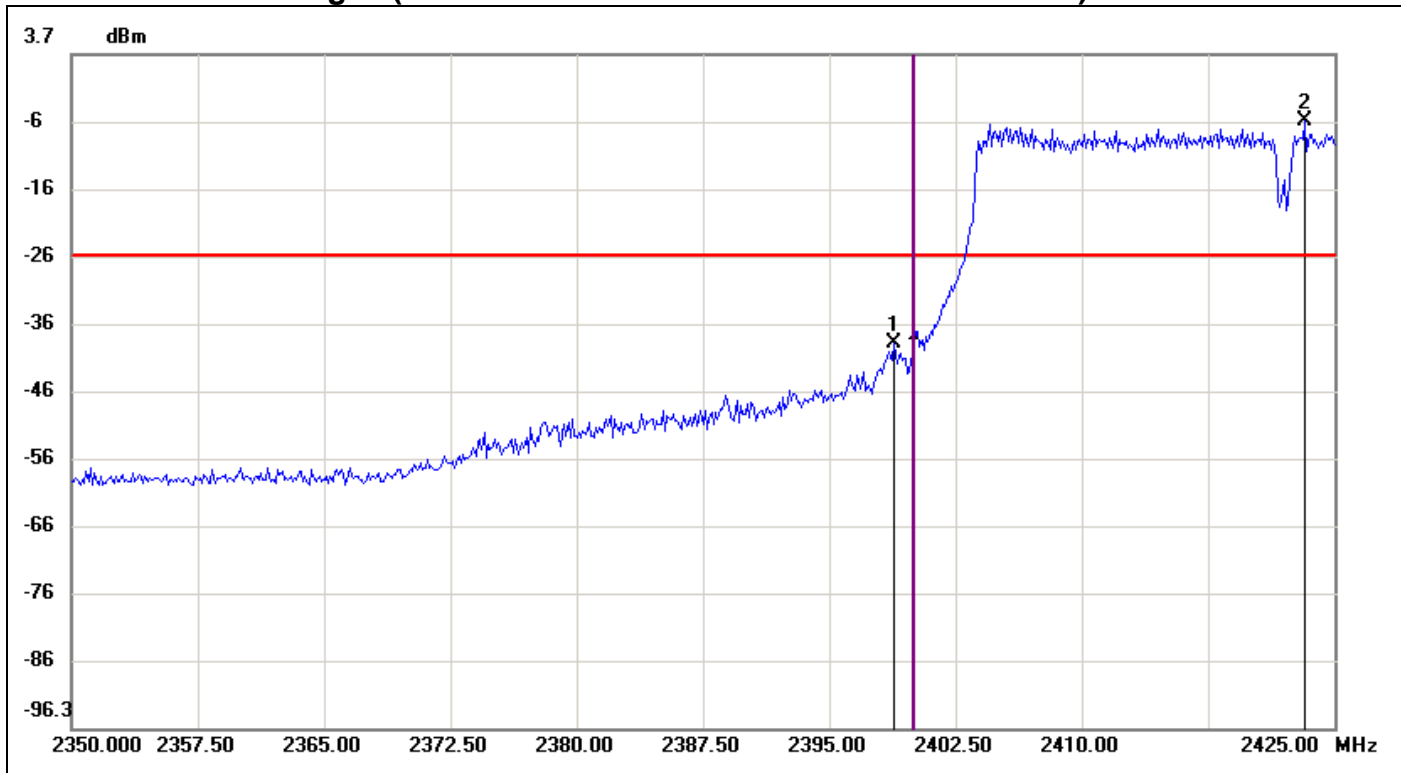

No.	Frequency(MHz)	Result(dBm)	Limit(dBm)	Margin(dBm)
1	2398.8750	-39.04	-26.22	-12.82
2	2423.2500	-6.22	-26.22	20.00

**Conducted Band Edges (IEEE 802.11n HT 40 mode / CH High / Chain 1)**

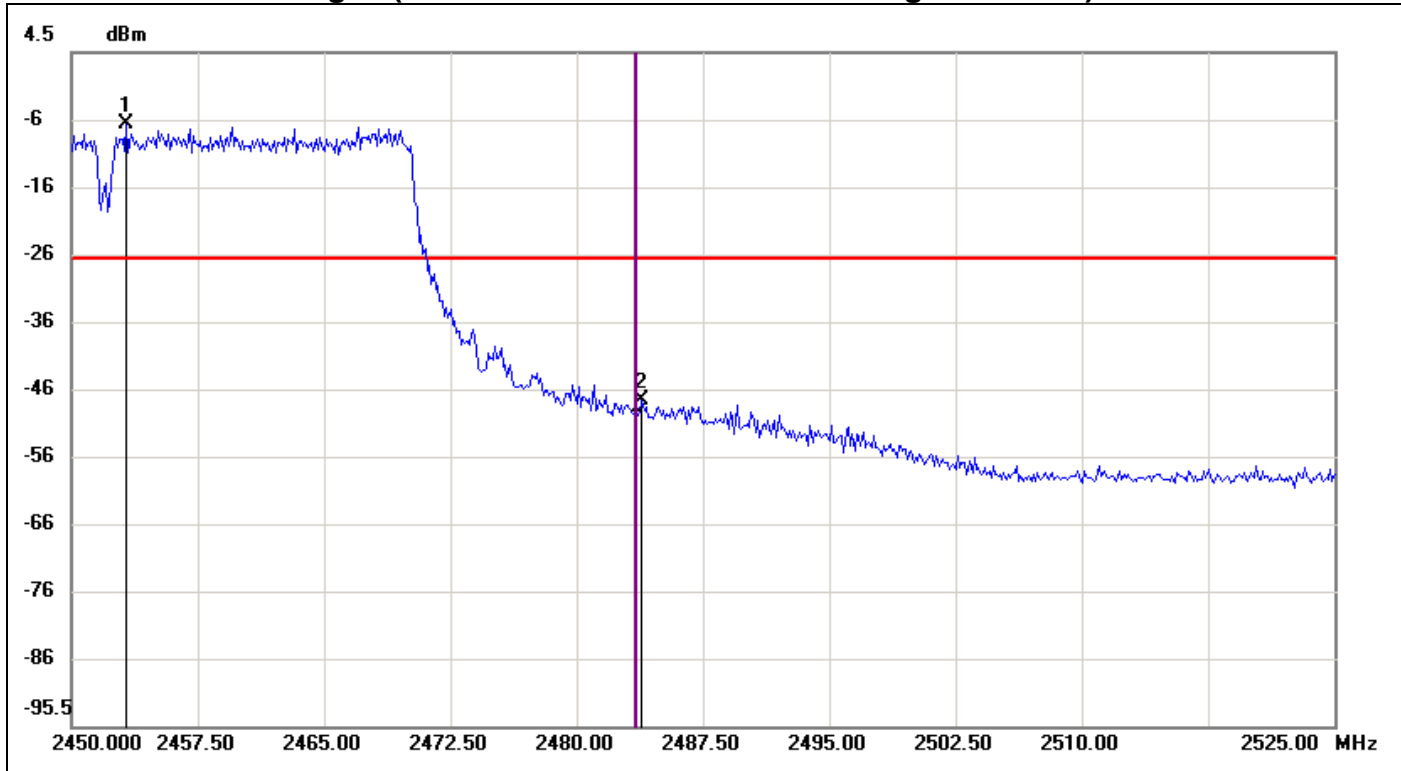

No.	Frequency(MHz)	Result(dBm)	Limit(dBm)	Margin(dBm)
1	2453.2500	-6.02	-26.02	20.00
2	2483.8750	-47.01	-26.02	-20.99

## **7.5 PEAK POWER SPECTRAL DENSITY**

### **LIMIT**

1. According to §15.247(e), for digitally modulated systems, the power spectral density conducted from the intentional radiator to the antenna shall not be greater than 8 dBm in any 3 kHz band during any time interval of continuous transmission.
2. According to §15.247(f), the digital modulation operation of the hybrid system, with the frequency hopping turned off, shall comply with the power density requirements of paragraph (d) of this section.

### **Test Configuration**

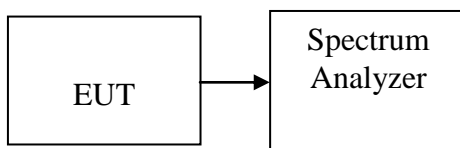

### **TEST PROCEDURE**

The transmitter output is connected to a spectrum analyzer. Set the RBW = 100 kHz, VBW ≥ 300 kHz, span to 1.5 times the DTS bandwidth, Detector = peak, Trace mode = max hold, Sweep = auto couple. Use the peak marker function to determine the maximum amplitude level within the RBW. If measured value exceeds limit, reduce RBW (no less than 3 kHz).

### **TEST RESULTS**

*No non-compliance noted.*

**Test Data**

**Test mode: IEEE 802.11b mode**

Channel	Frequency (MHz)	PPSD (dBm)	Limit (dBm)	Result
Low	2412	-5.19	7.1	PASS
Mid	2437	-4.51		PASS
High	2462	-10.08		PASS

**Test mode: IEEE 802.11g mode**

Channel	Frequency (MHz)	PPSD (dBm)	Limit (dBm)	Result
Low	2412	-9.08	7.1	PASS
Mid	2437	-0.34		PASS
High	2462	-10.00		PASS

**Test mode: IEEE 802.11n HT 20 mode**

Channel	Frequency (MHz)	Chain 0 PPSD	Chain 1 PPSD	PPSD (dBm)	Limit (dBm)	Result
Low	2412	-9.25	-11.31	-7.15	4.89	PASS
Mid	2437	-1.93	-3.48	0.37		PASS
High	2462	-10.46	-11.16	-7.79		PASS

**Test mode: IEEE 802.11n HT 40 mode**

Channel	Frequency (MHz)	Chain 0 PPSD	Chain 1 PPSD	PPSD (dBm)	Limit (dBm)	Result
Low	2422	-12.00	-14.43	-10.04	4.89	PASS
Mid	2437	-11.46	-5.08	-4.18		PASS
High	2452	-12.69	-13.97	-10.27		PASS

**Remark:** Total PPSD (dBm) = 10\*LOG(10^(Chain 0 PPSD / 10)+10^(Chain 1 PPSD / 10))

**Test Plot**

**IEEE 802.11b mode**

**PPSD (CH Low)**

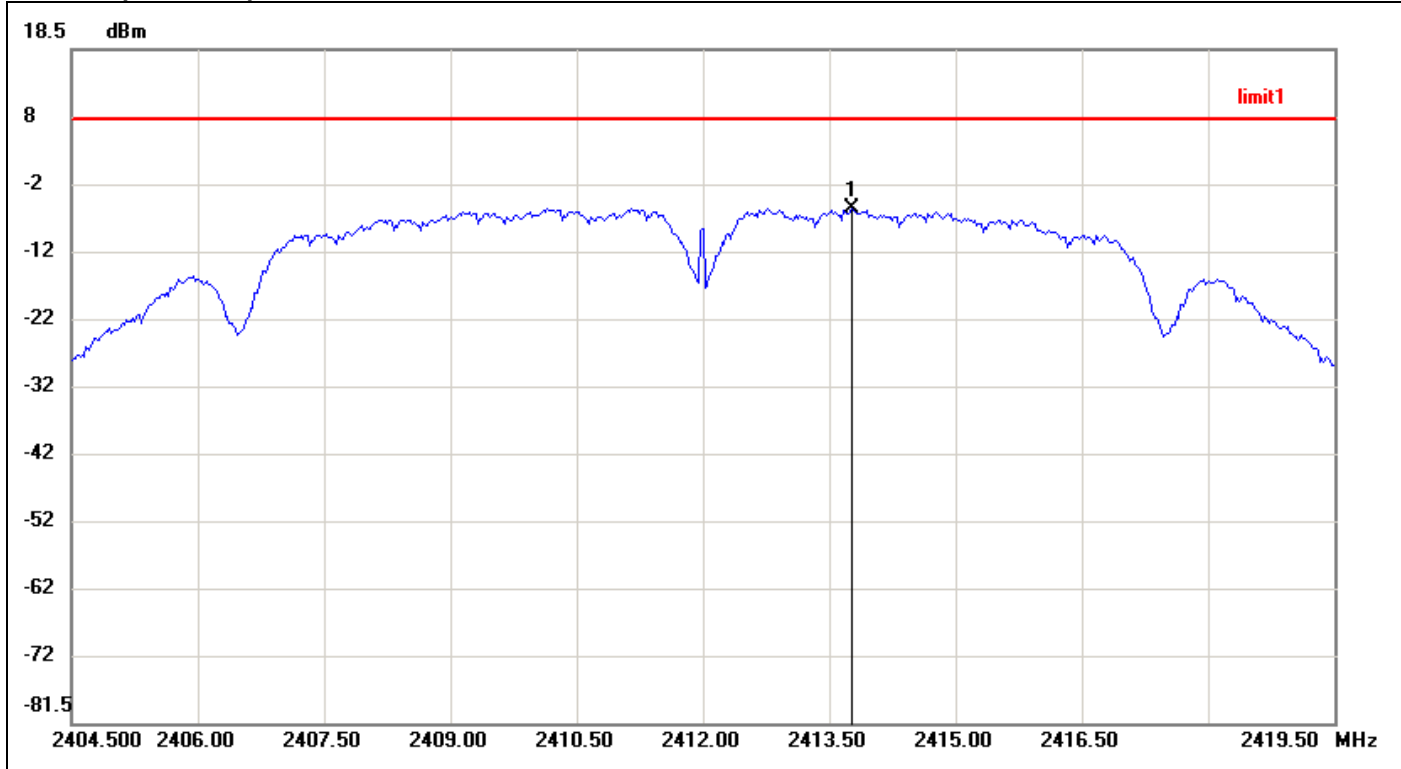

No.	Frequency(MHz)	Result(dBm)	Limit(dBm)	Margin(dBm)
1	2413.7750	-5.19	8.00	-13.19

**PPSD (CH Mid)**

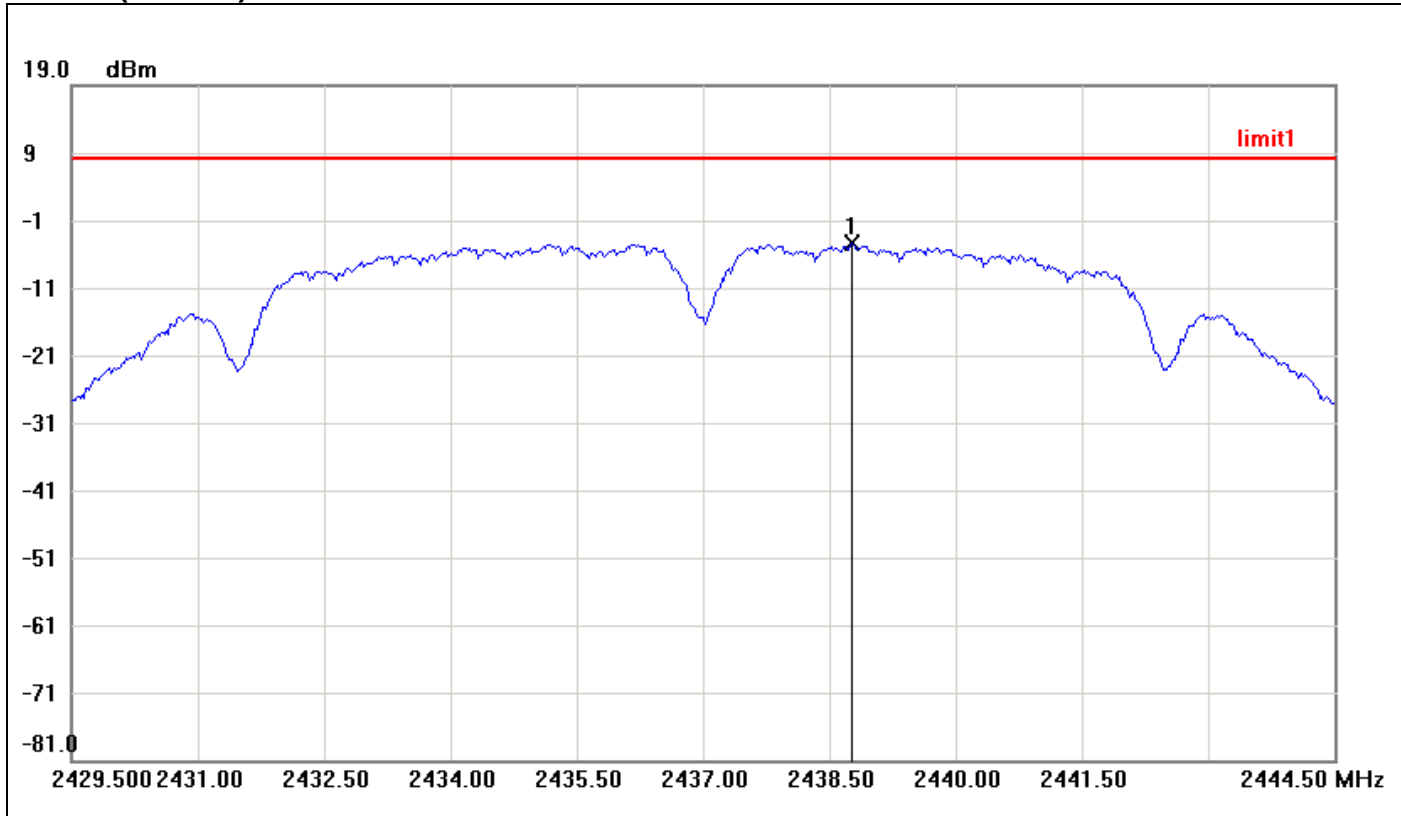

No.	Frequency(MHz)	Result(dBm)	Limit(dBm)	Margin(dBm)
1	2438.7750	-4.51	8.00	-12.51

**PPSD (CH High)**

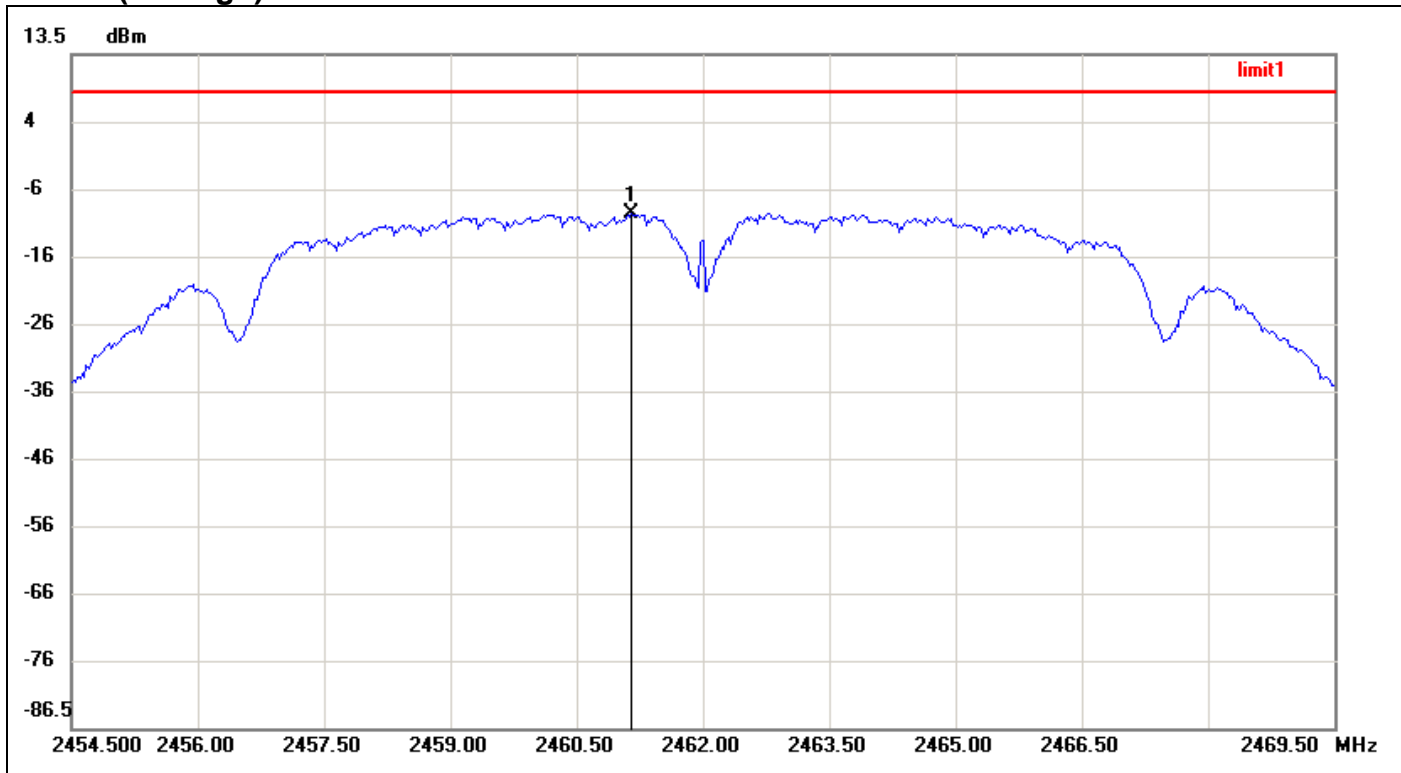

No.	Frequency(MHz)	Result(dBm)	Limit(dBm)	Margin(dBm)
1	2461.1500	-10.08	8.00	-18.08



**IEEE 802.11g mode**

**PPSD (CH Low)**

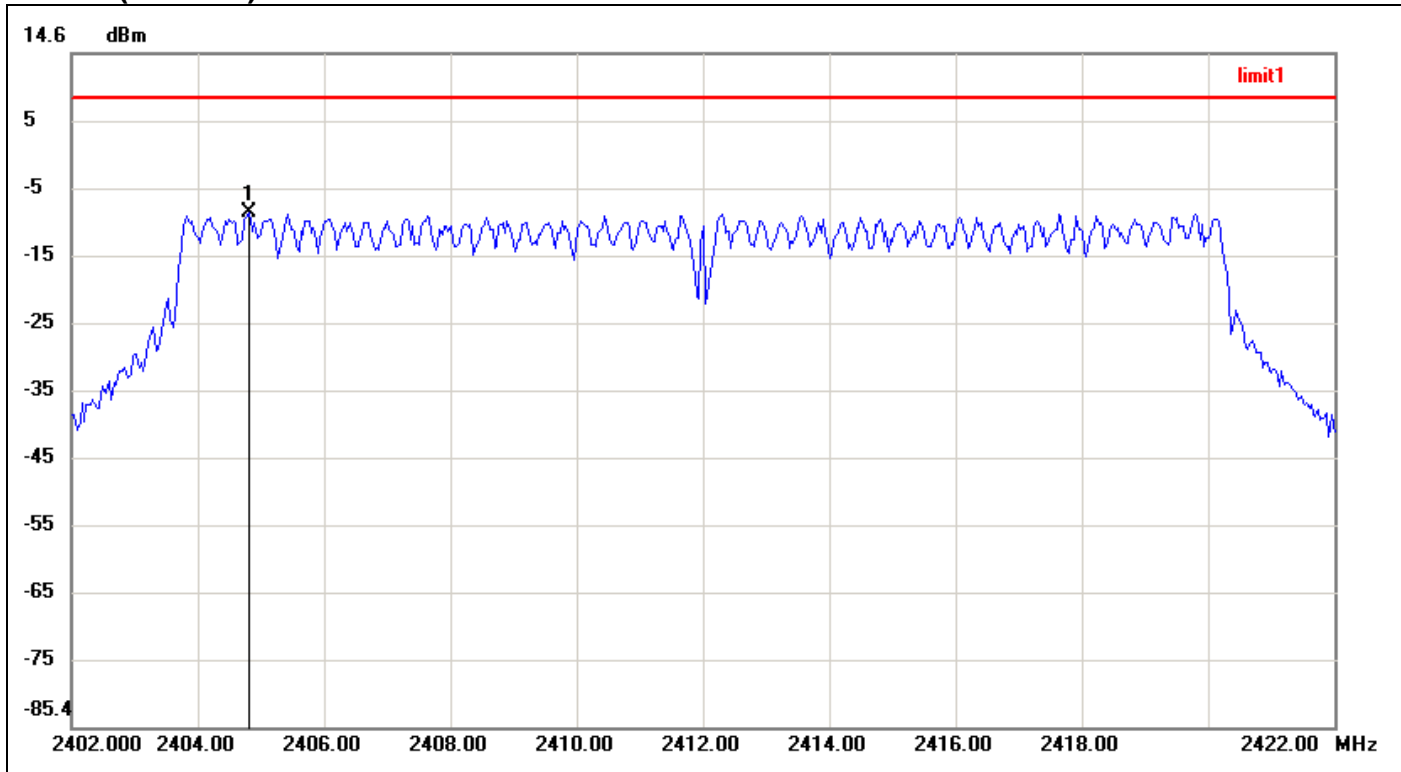

No.	Frequency(MHz)	Result(dBm)	Limit(dBm)	Margin(dBm)
1	2404.8000	-9.08	8.00	-17.08

**PPSD (CH Mid)**

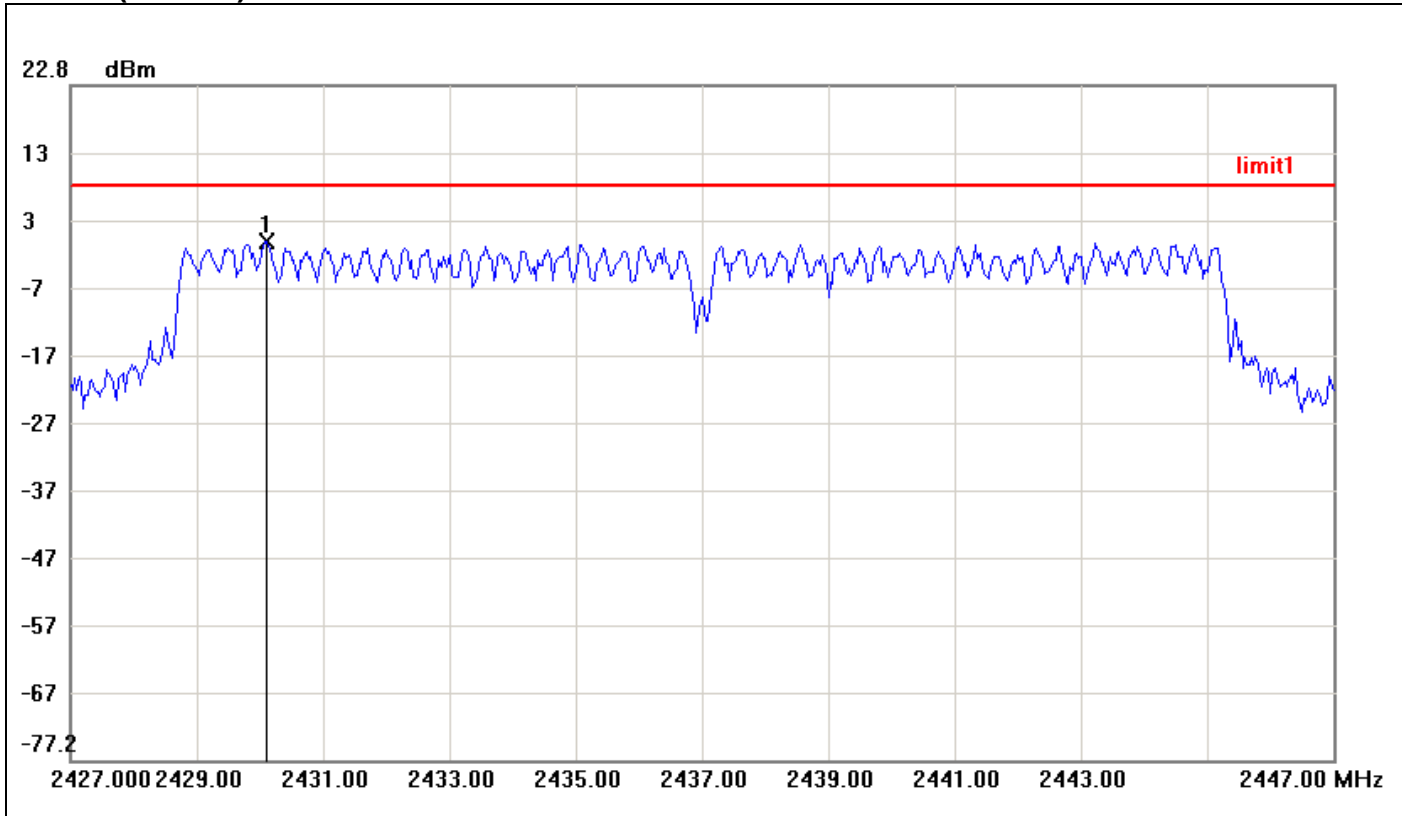

No.	Frequency(MHz)	Result(dBm)	Limit(dBm)	Margin(dBm)
1	2430.1000	-0.34	8.00	-8.34

**PPSD (CH High)**

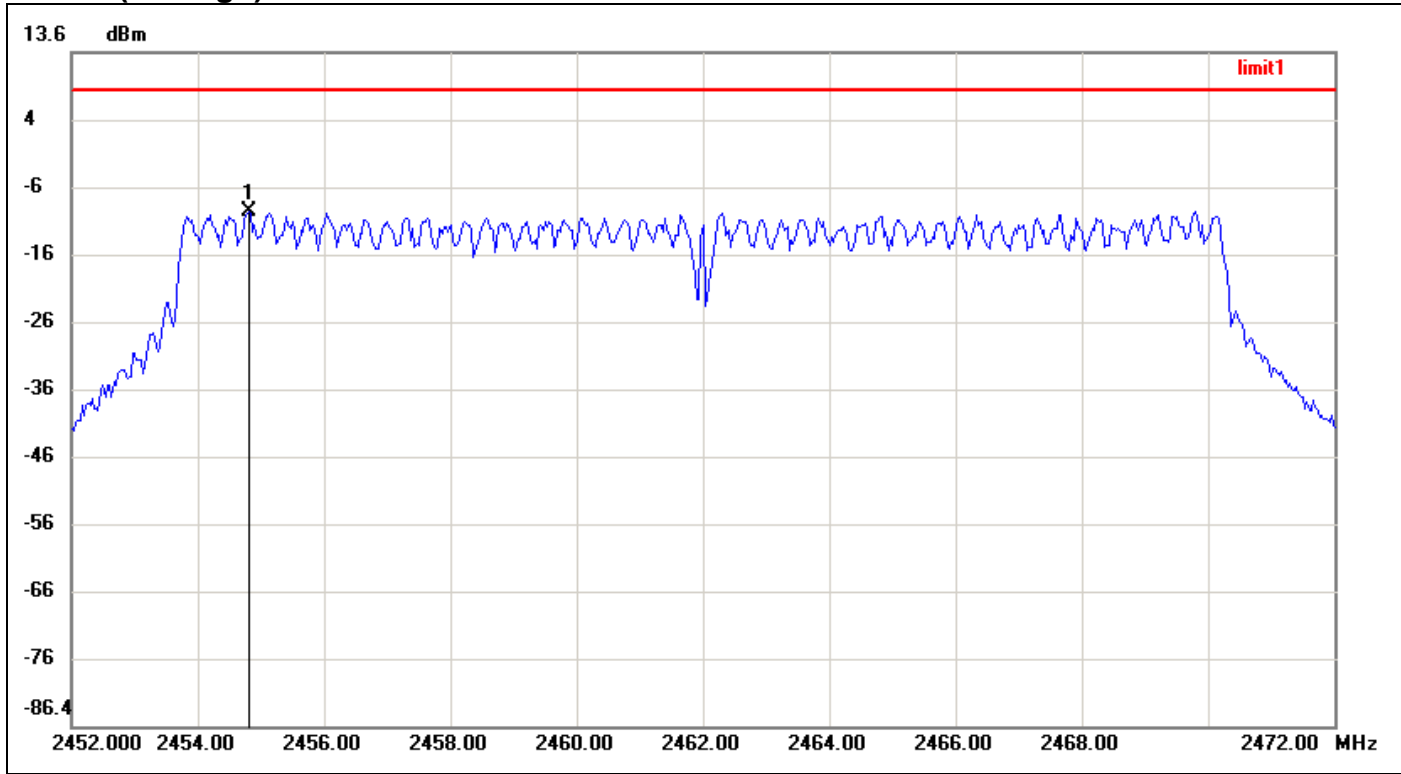

No.	Frequency(MHz)	Result(dBm)	Limit(dBm)	Margin(dBm)
1	2454.8000	-10.00	8.00	-18.00

**IEEE 802.11n HT 20 mode / Chain 0**

**PPSD (CH Low)**

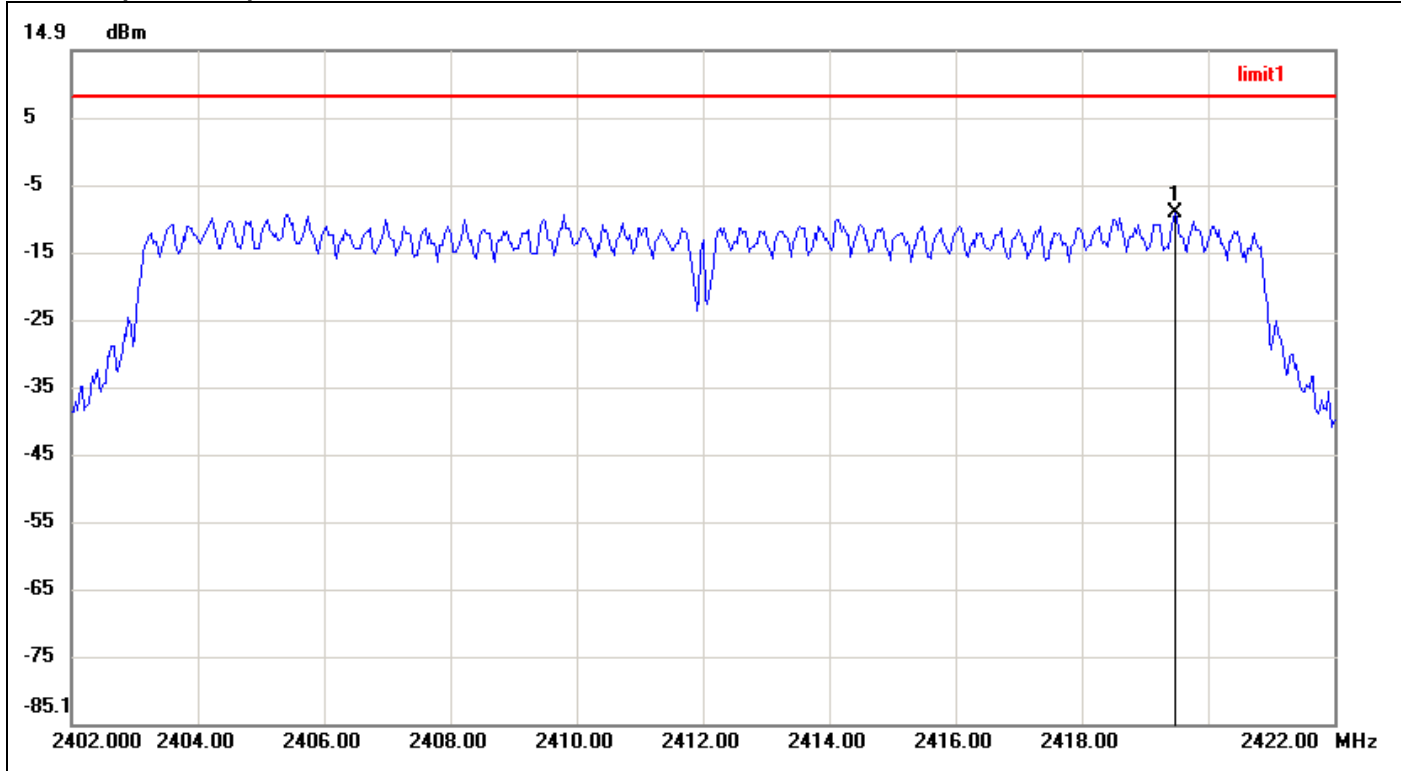

No.	Frequency(MHz)	Result(dBm)	Limit(dBm)	Margin(dBm)
1	2419.4667	-9.25	8.00	-17.25

**PPSD (CH Mid)**

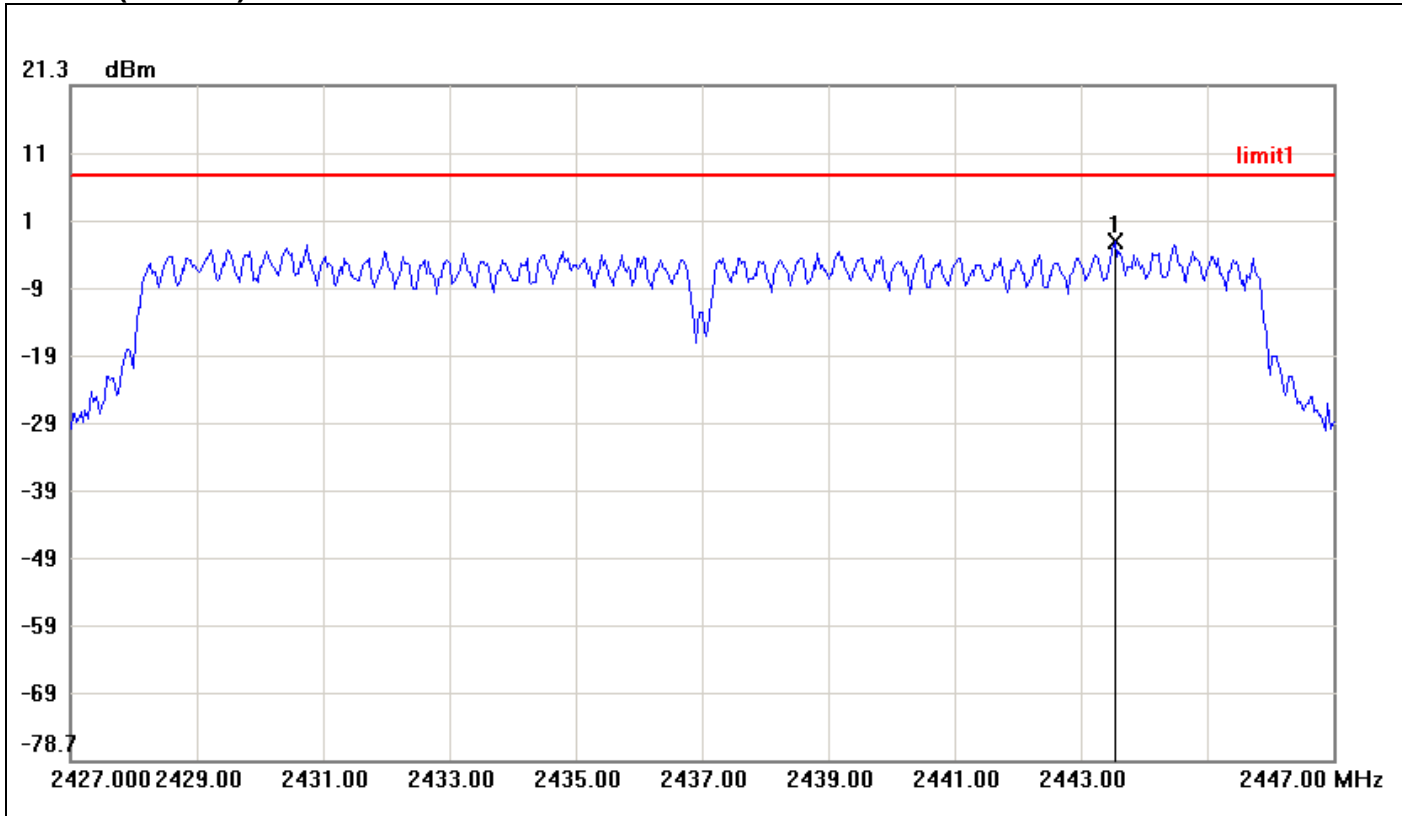

No.	Frequency(MHz)	Result(dBm)	Limit(dBm)	Margin(dBm)
1	2443.5333	-1.93	8.00	-9.93

**PPSD (CH High)**

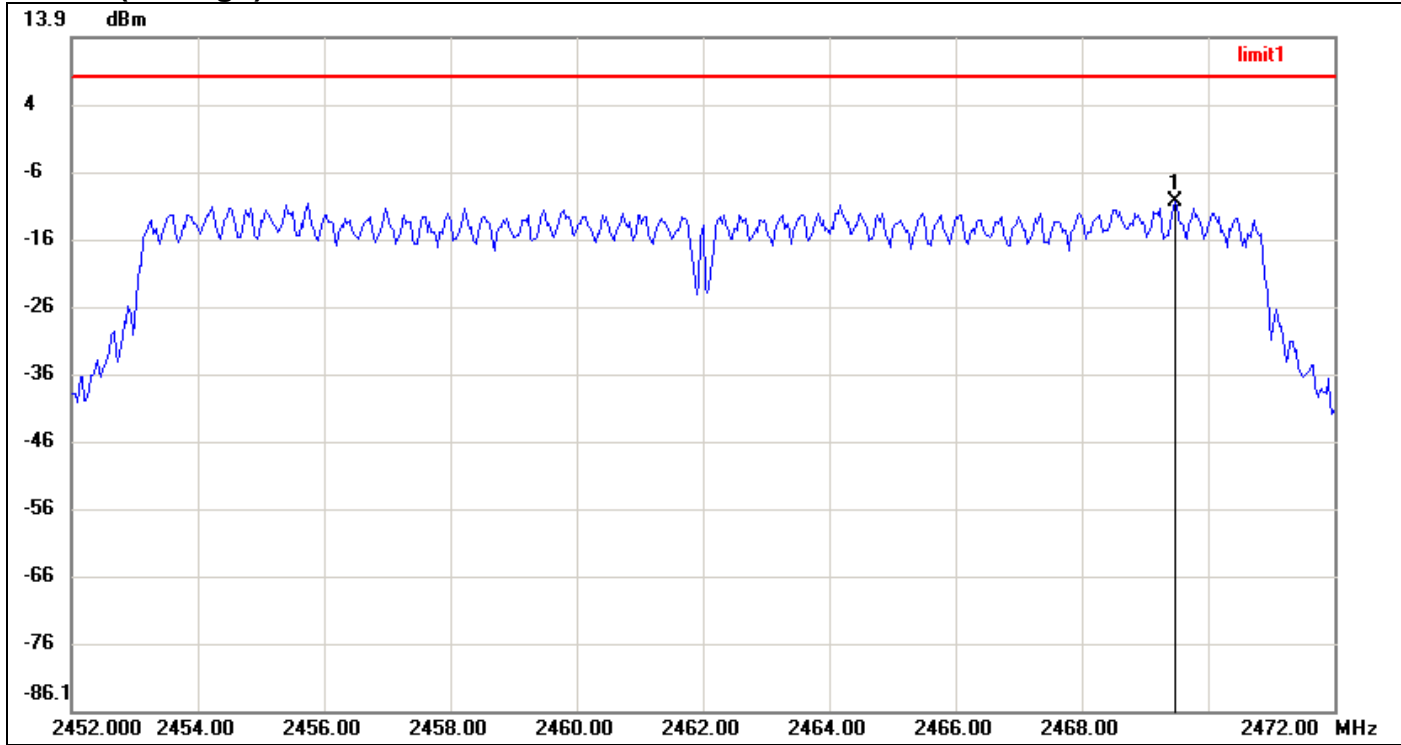

No.	Frequency(MHz)	Result(dBm)	Limit(dBm)	Margin(dBm)
1	2469.4667	-10.46	8.00	-18.46

**IEEE 802.11n HT 20 mode / Chain 1**

**PPSD (CH Low)**

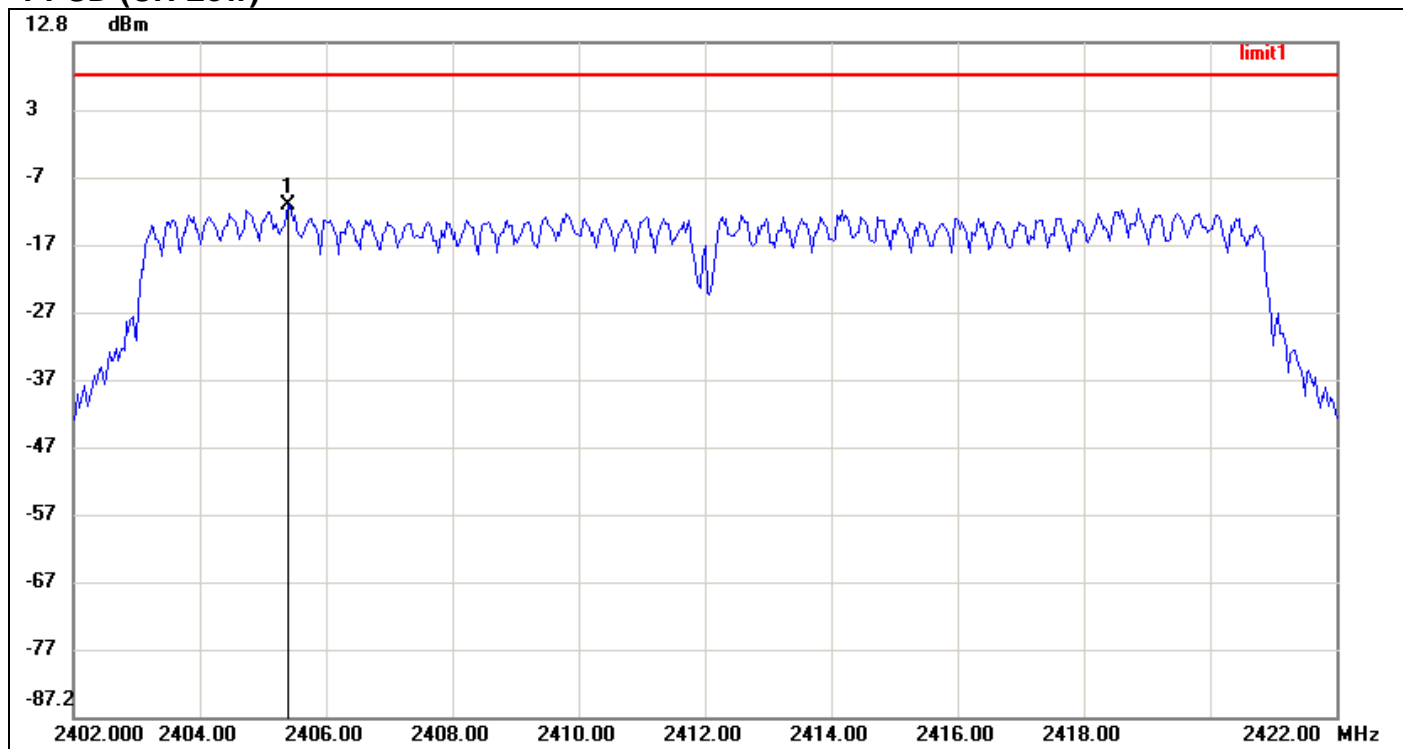

No.	Frequency(MHz)	Result(dBm)	Limit(dBm)	Margin(dBm)
1	2405.4000	-11.31	8.00	-19.31

**PPSD (CH Mid)**

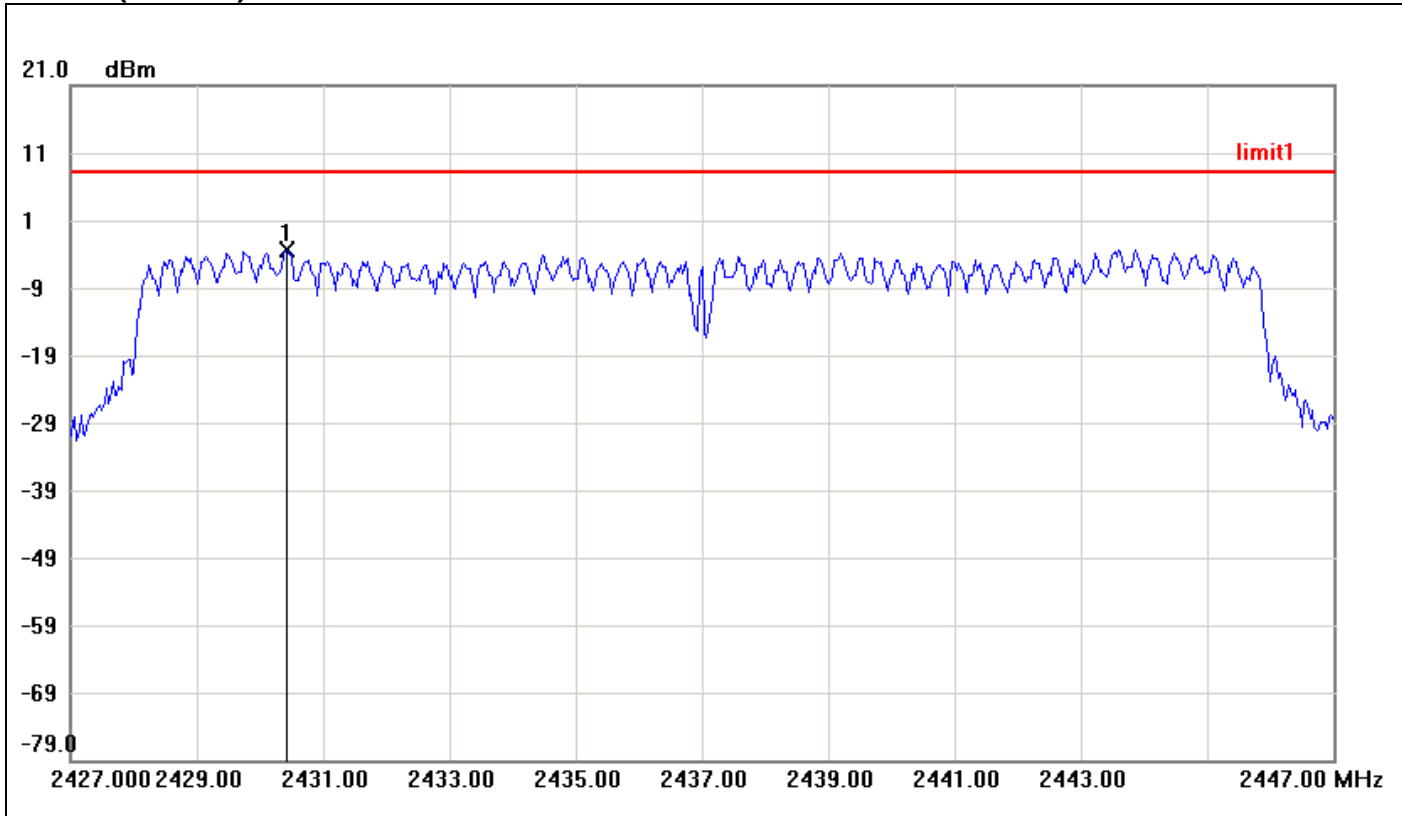

No.	Frequency(MHz)	Result(dBm)	Limit(dBm)	Margin(dBm)
1	2430.4333	-3.48	8.00	-11.48



**PPSD (CH High)**

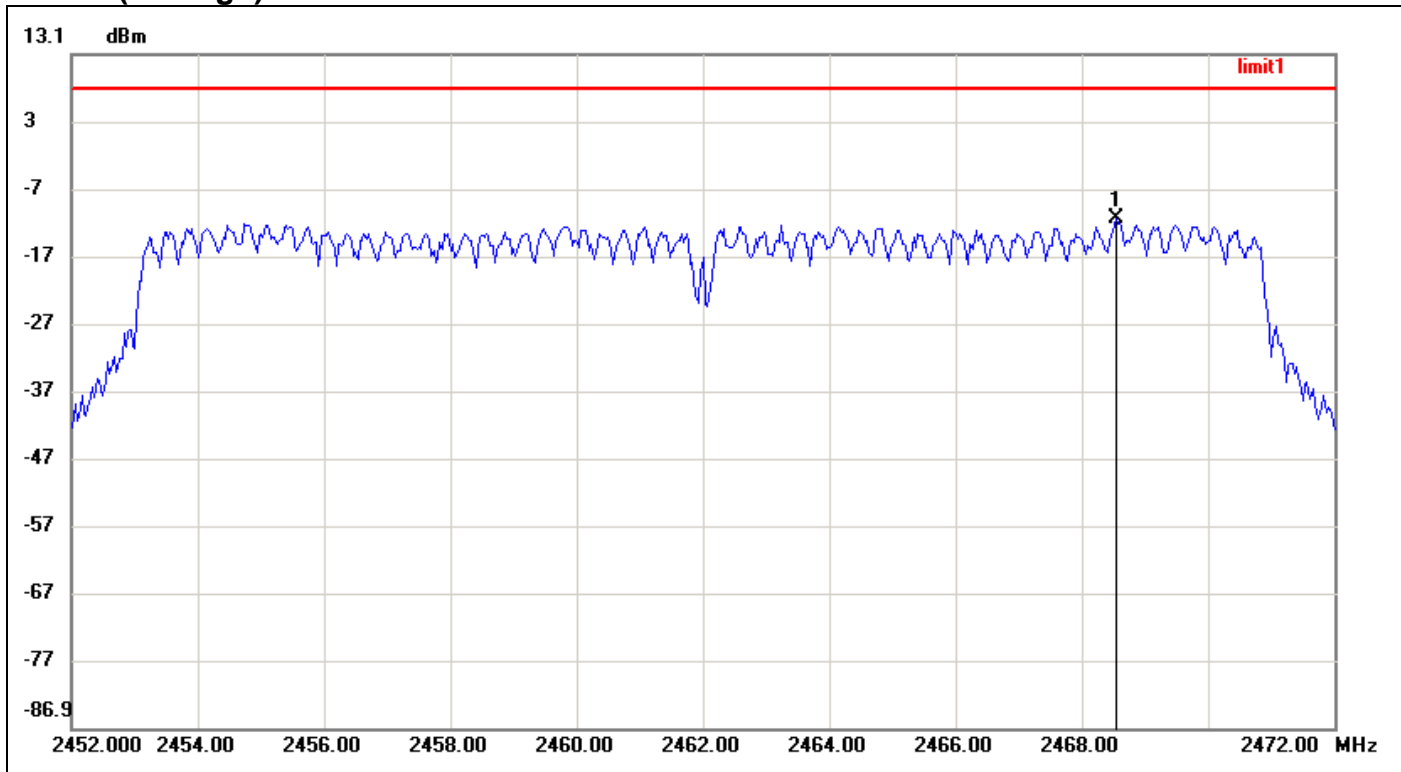

No.	Frequency(MHz)	Result(dBm)	Limit(dBm)	Margin(dBm)
1	2468.5333	-11.16	8.00	-19.16

**IEEE 802.11n HT 40 mode / Chain 0**

**PPSD (CH Low)**

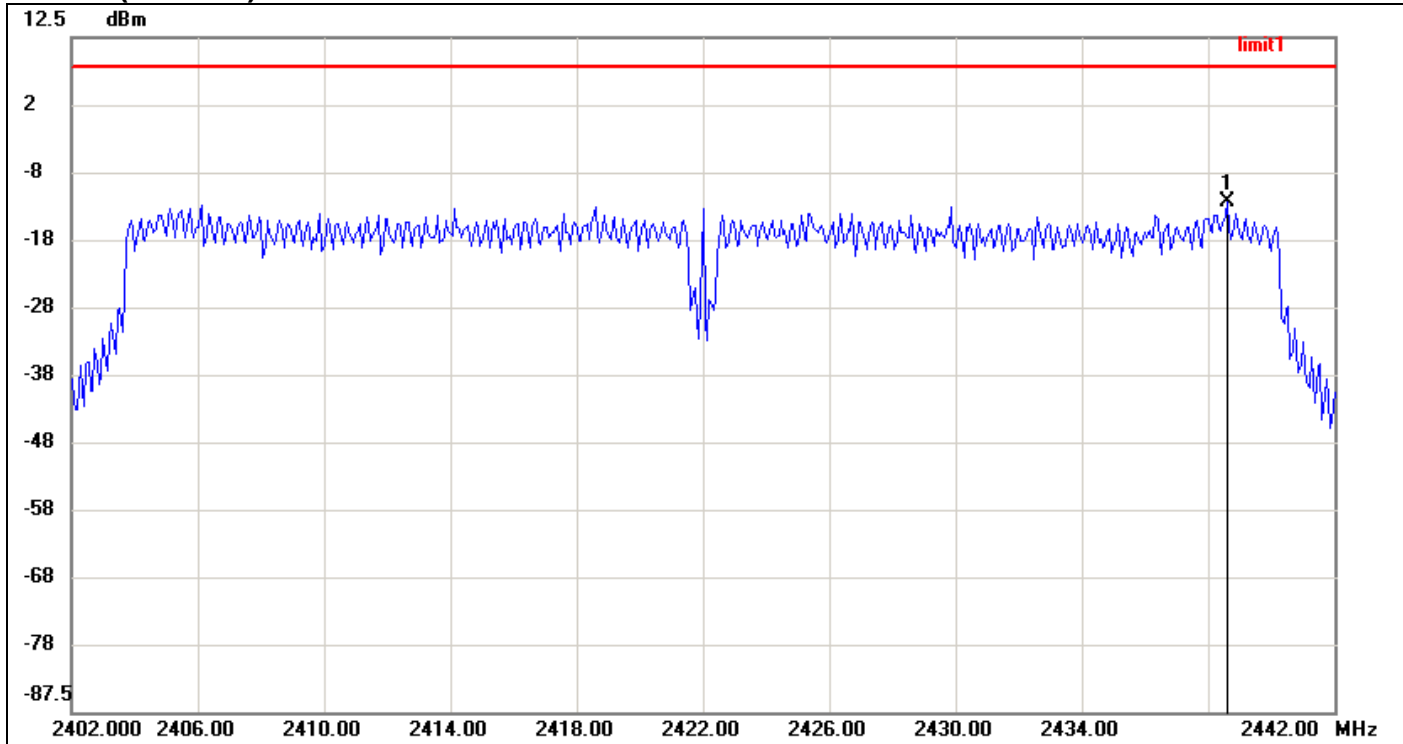

No.	Frequency(MHz)	Result(dBm)	Limit(dBm)	Margin(dBm)
1	2438.6000	-12.00	8.00	-20.00

**PPSD (CH Mid)**

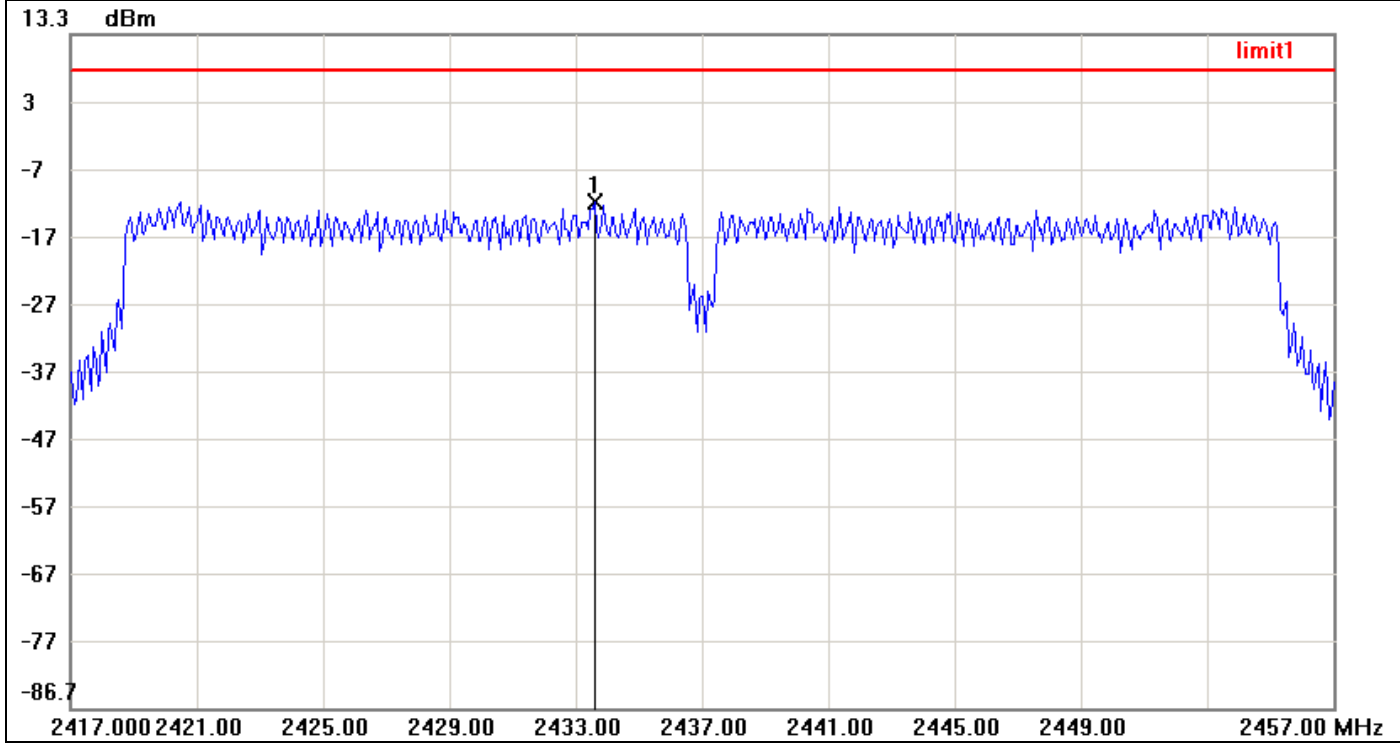

No.	Frequency(MHz)	Result(dBm)	Limit(dBm)	Margin(dBm)
1	2433.6000	-11.46	8.00	-19.46

**PPSD (CH High)**

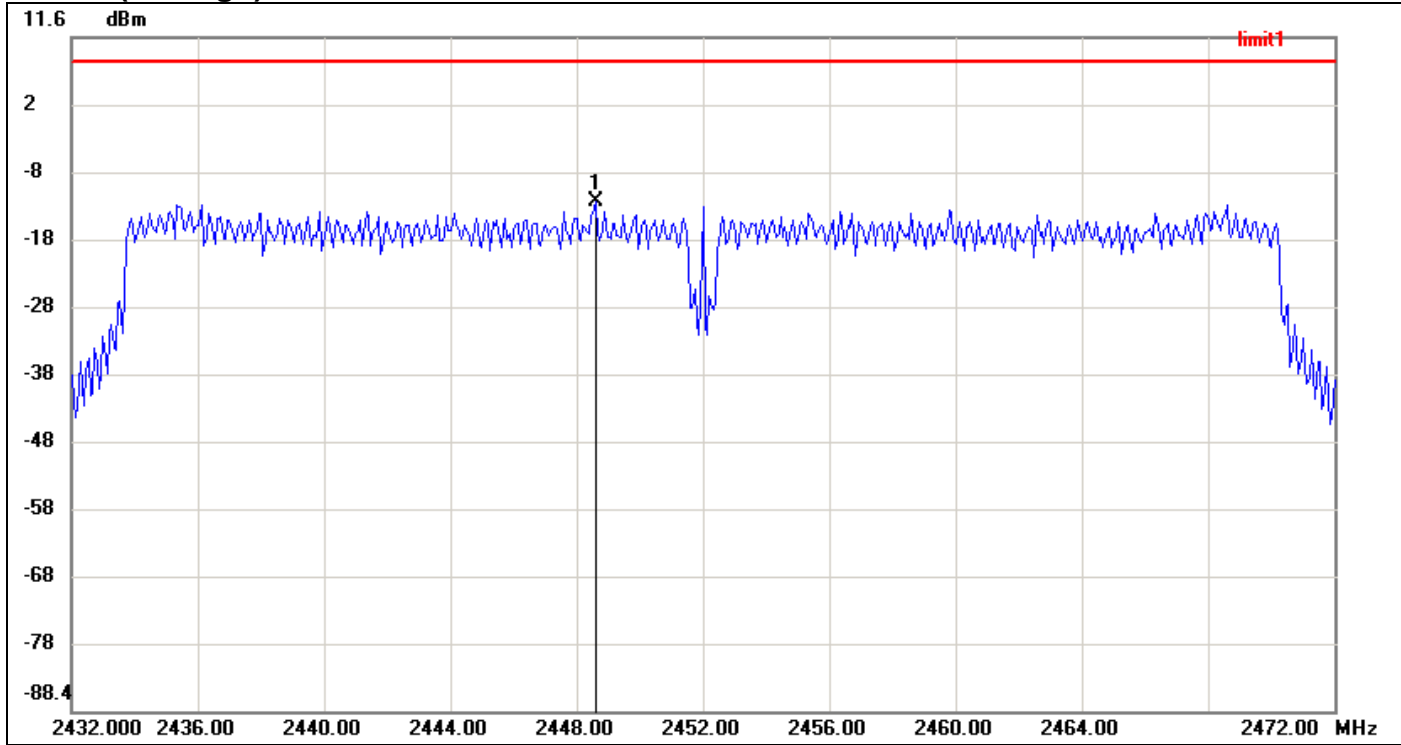

No.	Frequency(MHz)	Result(dBm)	Limit(dBm)	Margin(dBm)
1	2448.6000	-12.69	8.00	-20.69

**IEEE 802.11n HT 40 mode / Chain 1**

**PPSD (CH Low)**

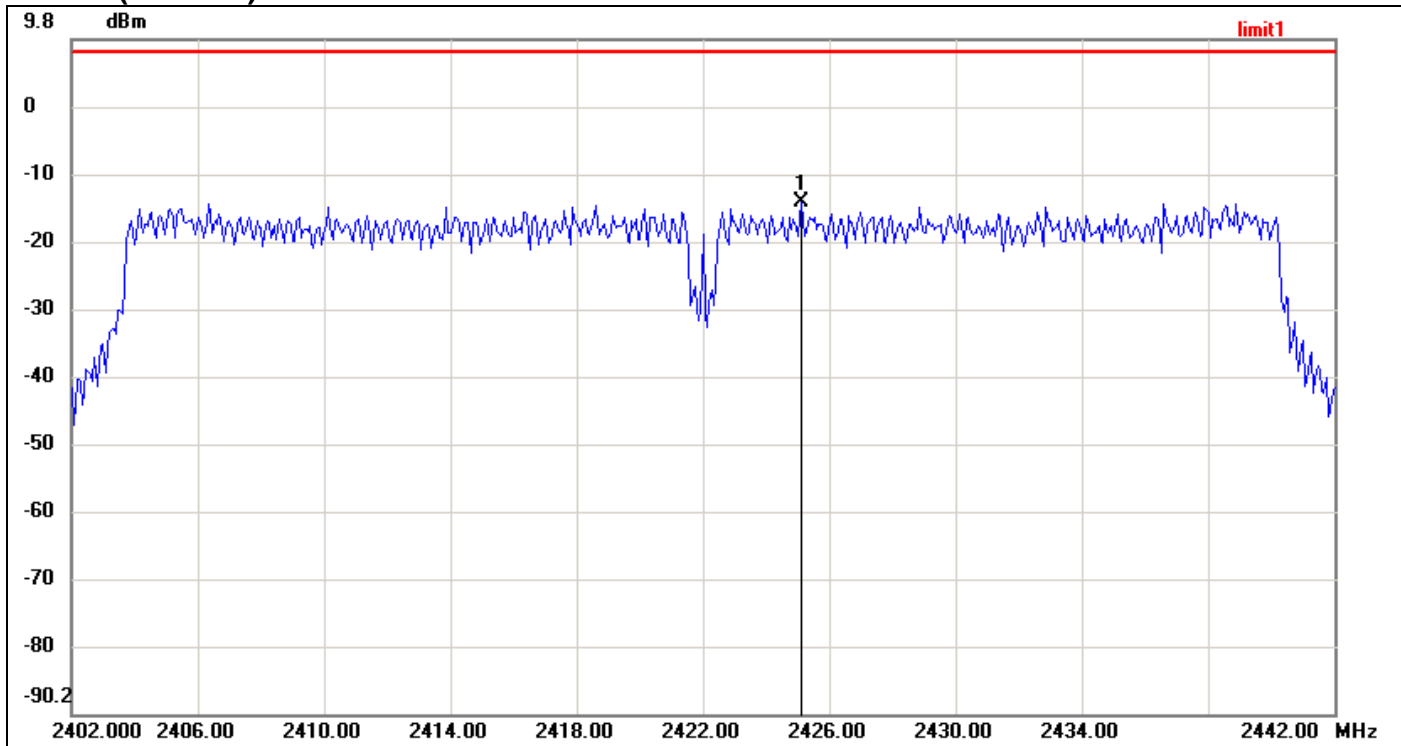

No.	Frequency(MHz)	Result(dBm)	Limit(dBm)	Margin(dBm)
1	2425.1333	-14.43	8.00	-22.43

**PPSD (CH Mid)**

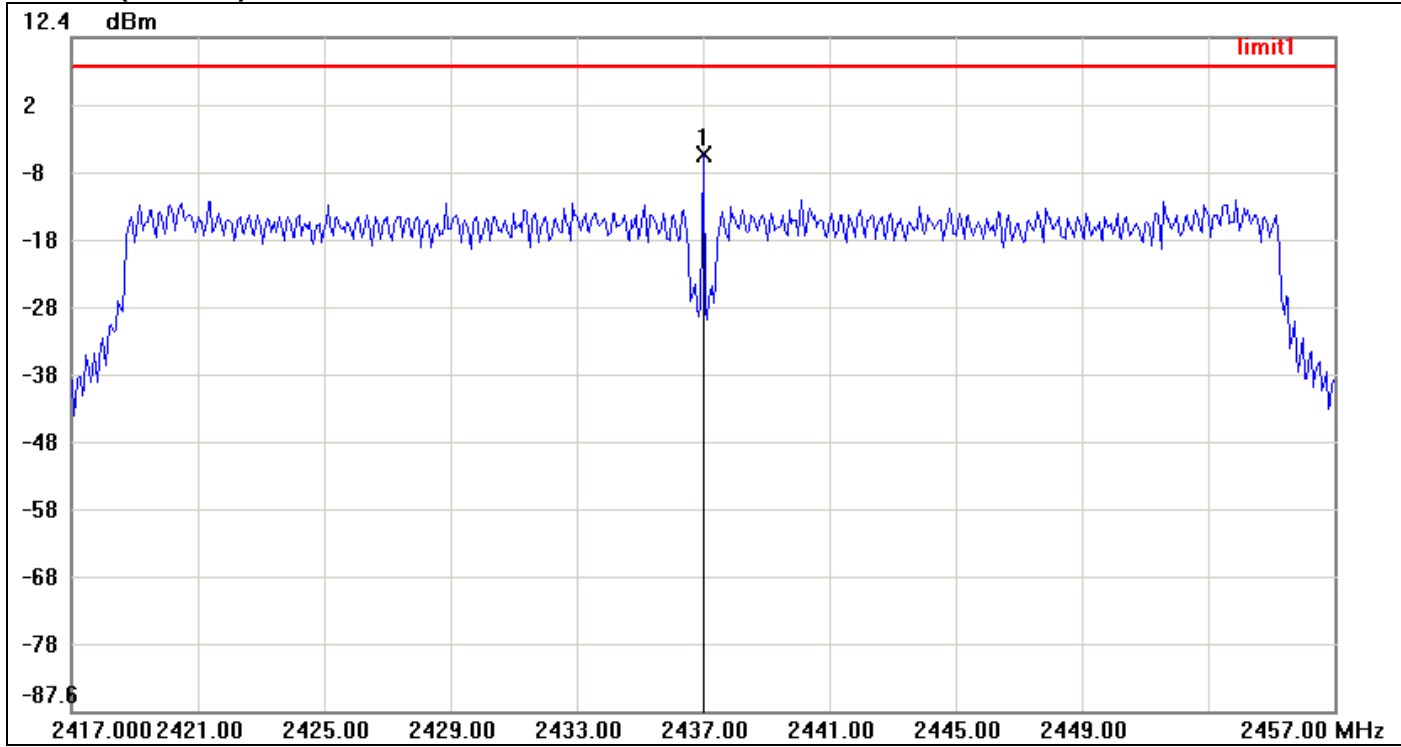

No.	Frequency(MHz)	Result(dBm)	Limit(dBm)	Margin(dBm)
1	2437.0000	-5.08	8.00	-13.08

**PPSD (CH High)**

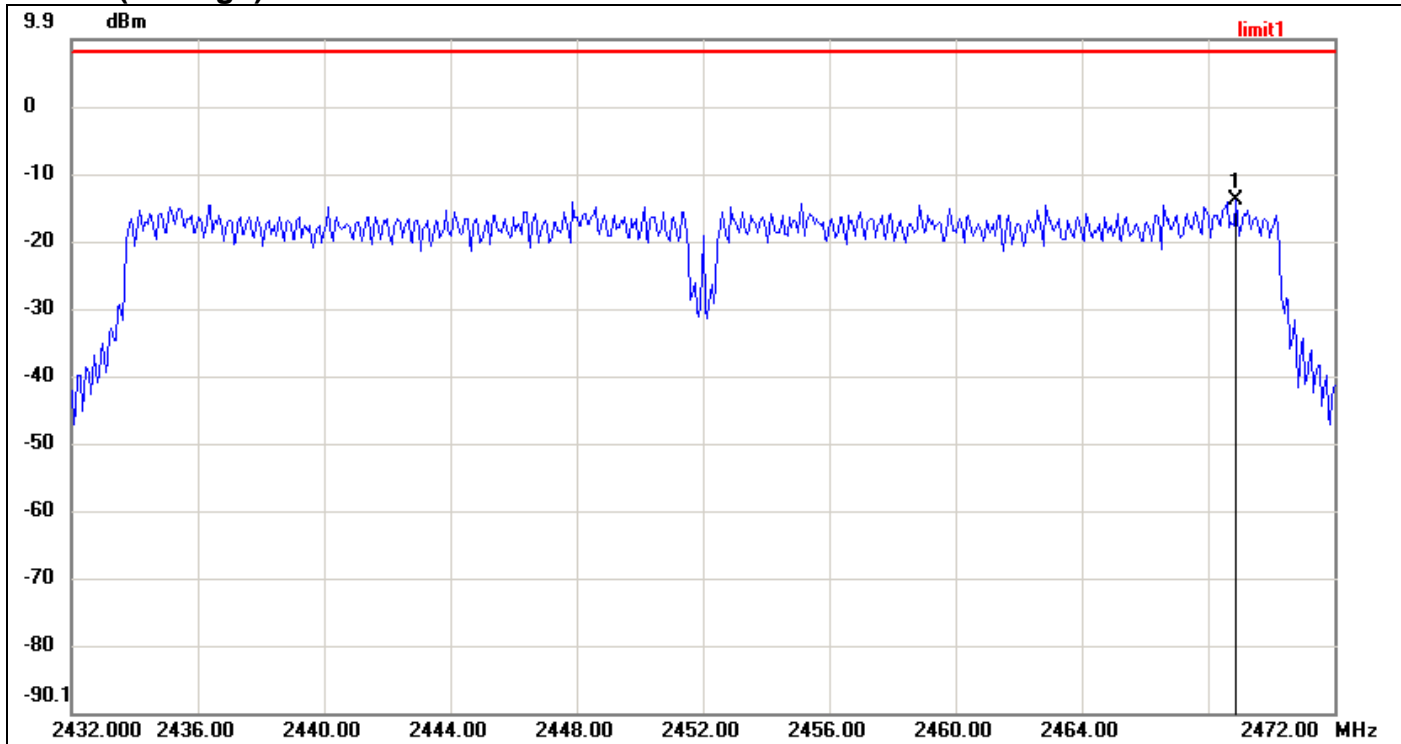

No.	Frequency(MHz)	Result(dBm)	Limit(dBm)	Margin(dBm)
1	2468.8667	-13.97	8.00	-21.97

## 7.6 SPURIOUS EMISSIONS

### 7.6.1 Conducted Measurement

#### LIMIT

According to §15.247(d), in any 100 kHz bandwidth outside the frequency bands in which the spread spectrum intentional radiator is operating, the radio frequency power that is produced by the intentional radiator shall be at least 20 dB below that in the 100 kHz bandwidth within the band that contains the highest level of the desired power, based on either an RF conducted or a radiated measurement, provided the transmitter demonstrates compliance with the peak conducted power limits. In addition, radiated emissions which fall in the restricted bands, as defined in §15.205(a), must also comply with the radiated emission limits specified in 15.209(a) (see Section 15.205(c)).

#### Test Configuration

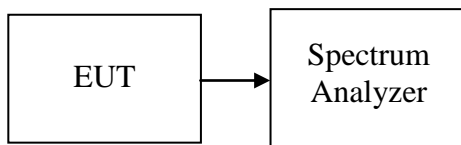

#### TEST PROCEDURE

The transmitter output is connected to a spectrum analyzer. Set the RBW=100 kHz and VBW= 300 kHz. Investigate the frequency from 30 MHz to 26 GHz with L, M and H channels separately.

#### TEST RESULTS

*No non-compliance noted.*



**Test Plot**

**IEEE 802.11b mode**

**CH Low**

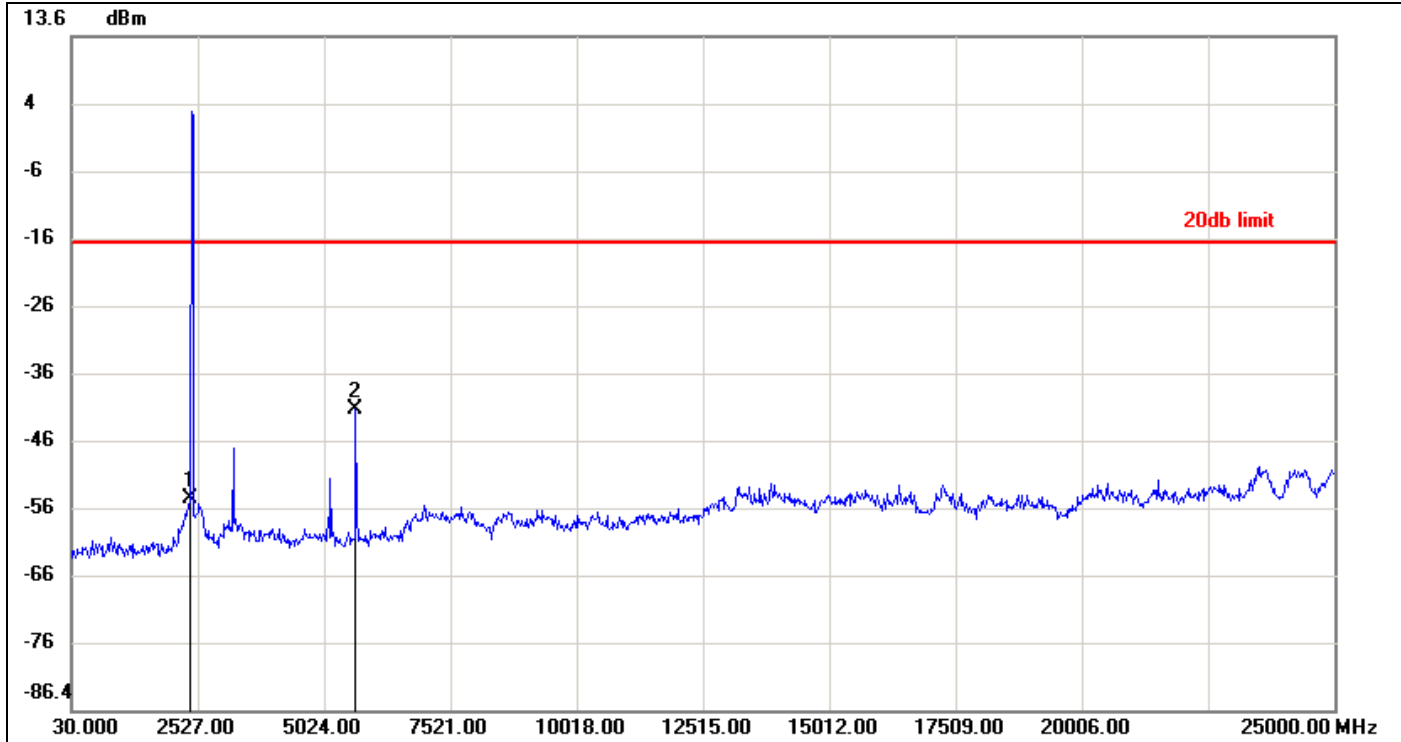

No.	Frequency(MHz)	Result(dBm)	Limit(dBm)	Margin(dBm)
1	2377.1800	-55.03	-16.94	-38.09
2	5648.2500	-41.73	-16.94	-24.79

**CH Mid**



No.	Frequency(MHz)	Result(dBm)	Limit(dBm)	Margin(dBm)
1	2302.2700	-51.73	-11.86	-39.87
2	3251.1300	-48.41	-11.86	-36.55

**CH High**

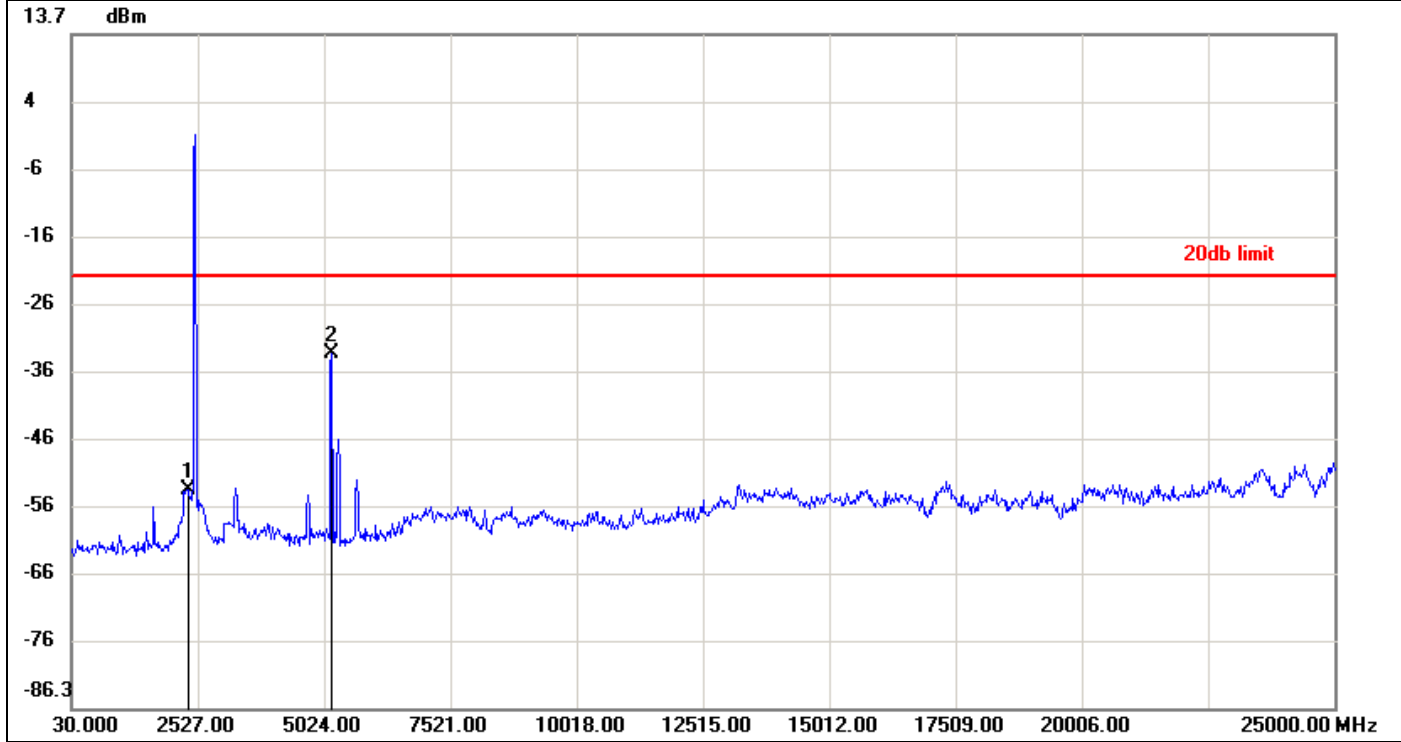

No.	Frequency(MHz)	Result(dBm)	Limit(dBm)	Margin(dBm)
1	2327.2400	-54.03	-22.14	-31.89
2	5173.8200	-33.73	-22.14	-11.55

**IEEE 802.11g mode**

**CH Low**

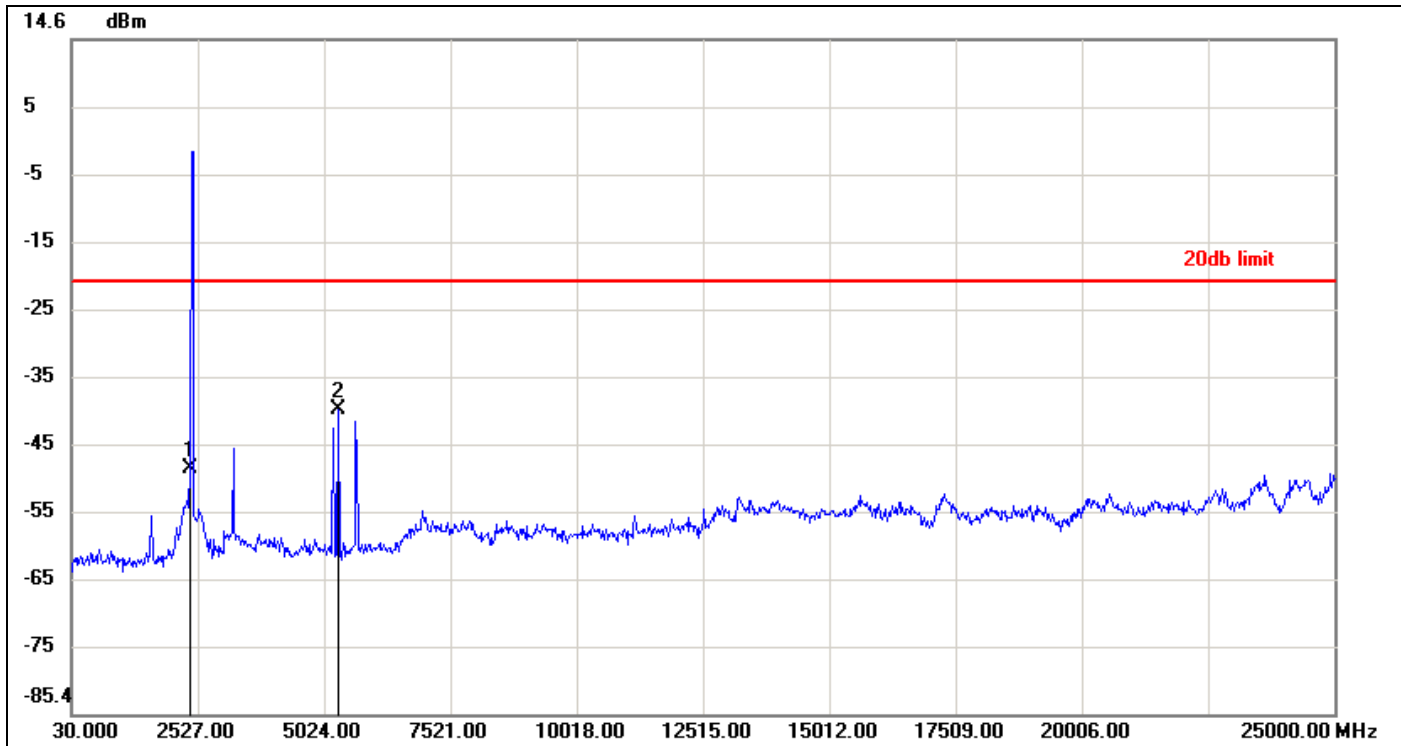

No.	Frequency(MHz)	Result(dBm)	Limit(dBm)	Margin(dBm)
1	2377.1800	-49.02	-21.28	-27.74
2	5298.6700	-40.37	-21.28	-19.09

**CH Mid**

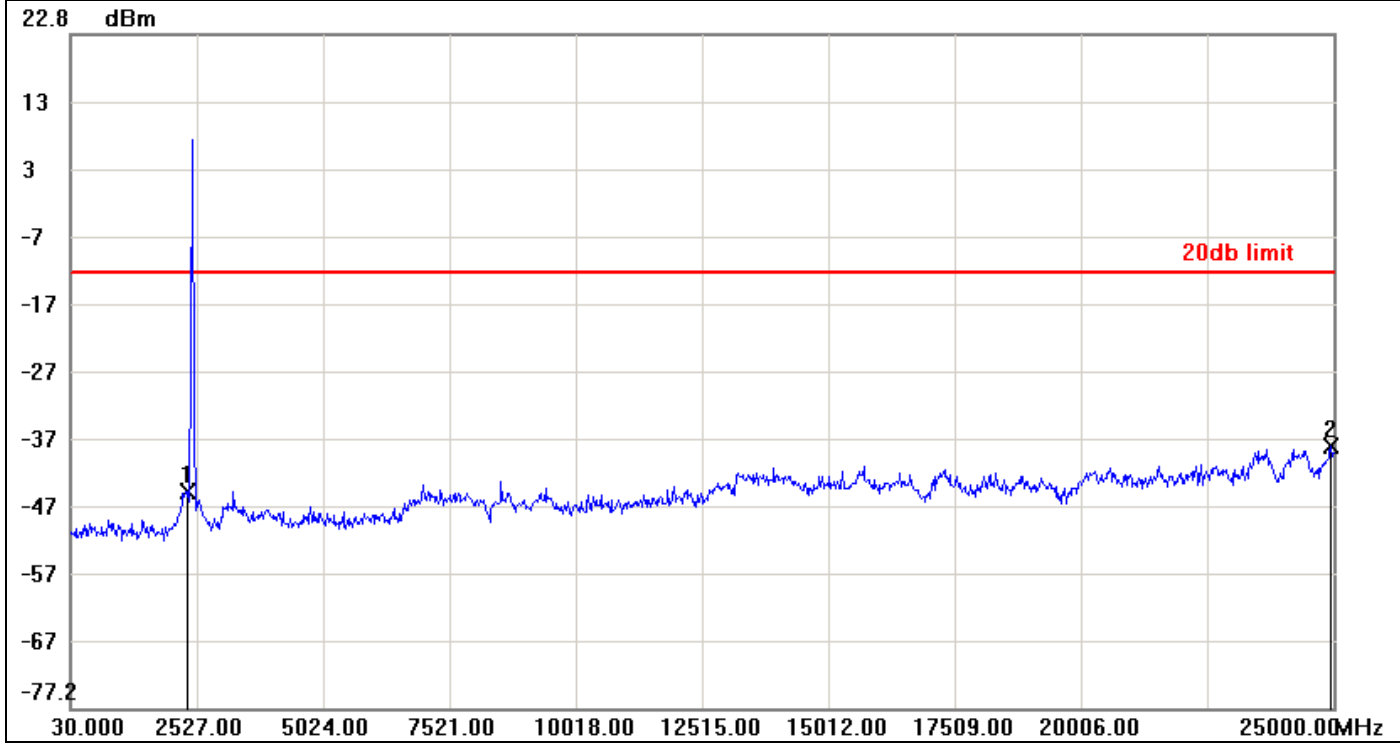

No.	Frequency(MHz)	Result(dBm)	Limit(dBm)	Margin(dBm)
1	2327.2400	-45.08	-12.58	-32.50
2	24950.0600	-38.43	-12.58	-25.85

**CH High**

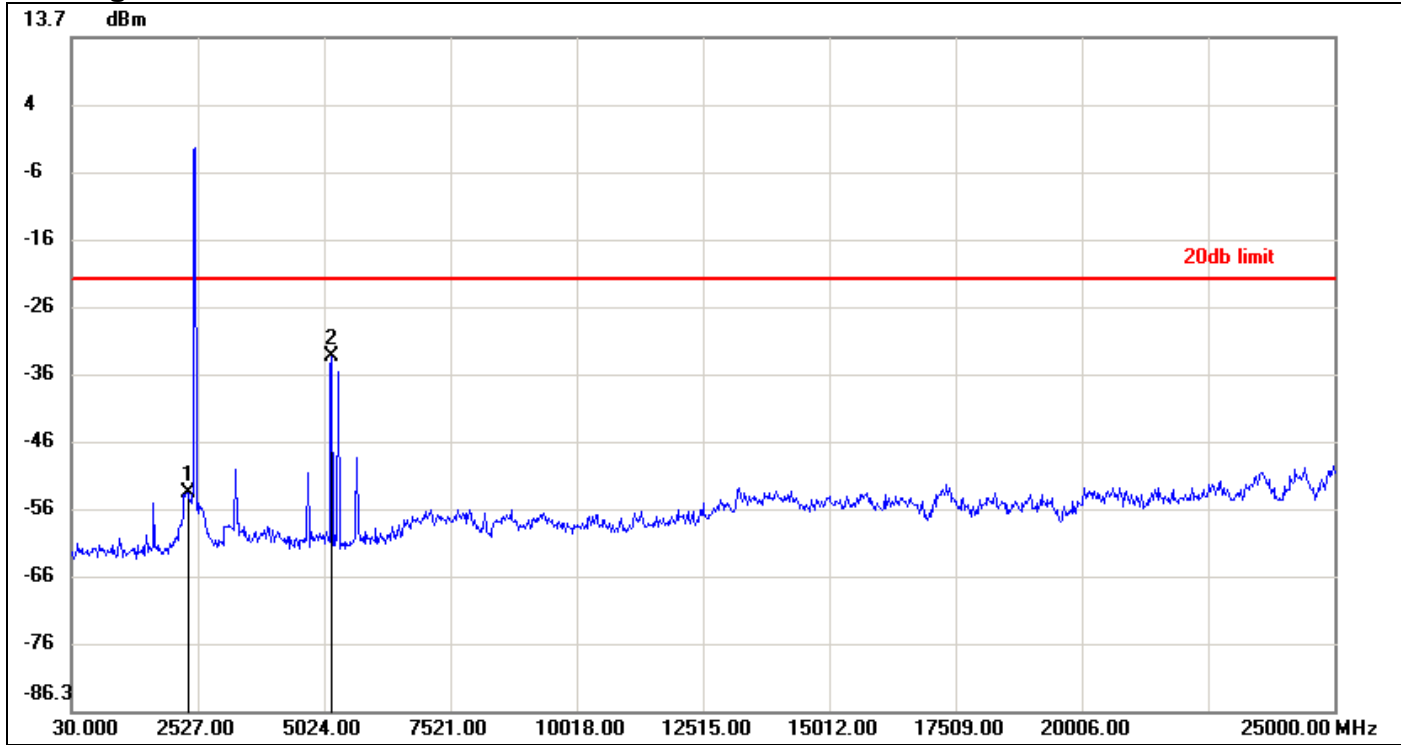

No.	Frequency(MHz)	Result(dBm)	Limit(dBm)	Margin(dBm)
1	2327.2400	-54.03	-22.18	-31.85
2	5173.8200	-33.73	-22.18	-11.55

**IEEE 802.11n HT 20 mode / Chain 0**

**CH Low**

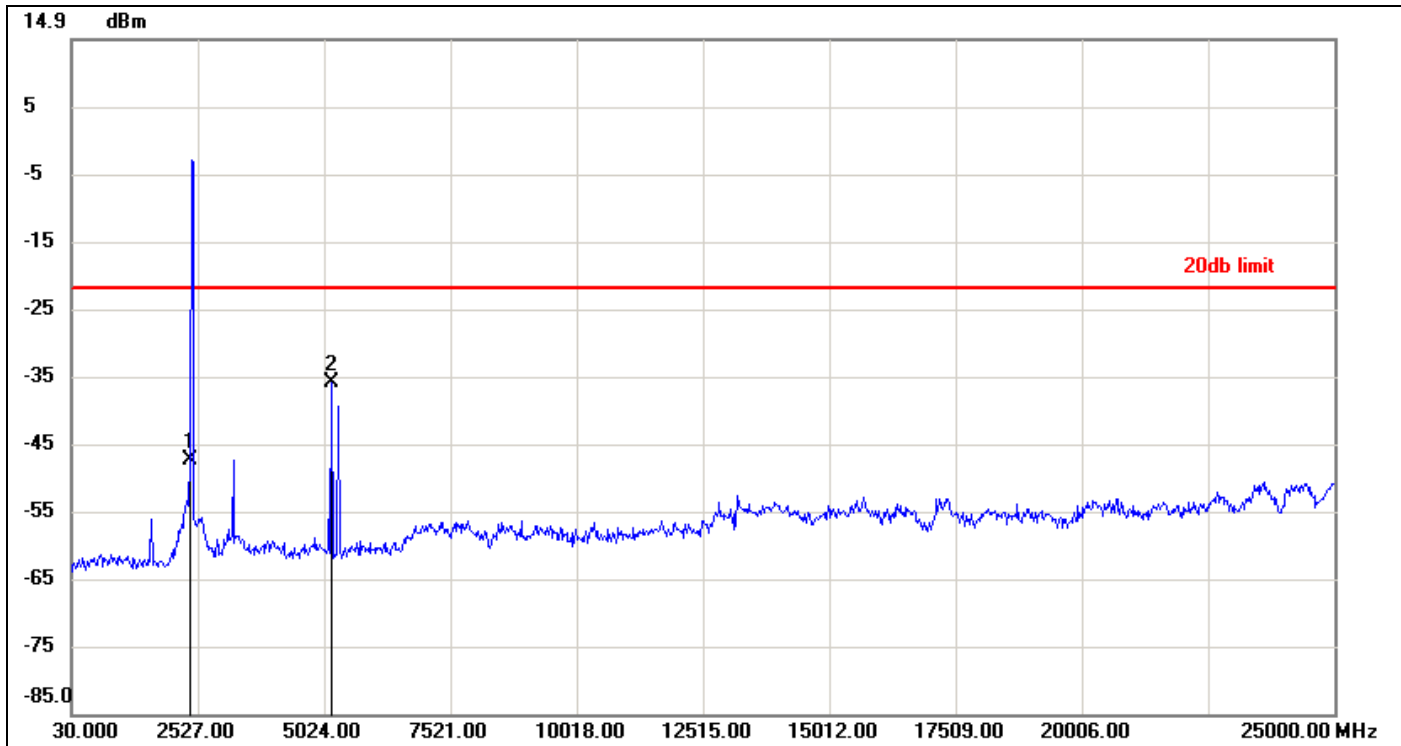

No.	Frequency(MHz)	Result(dBm)	Limit(dBm)	Margin(dBm)
1	2377.1800	-47.30	-21.96	-25.34
2	5173.8200	-35.88	-21.96	-13.92

**CH Mid**

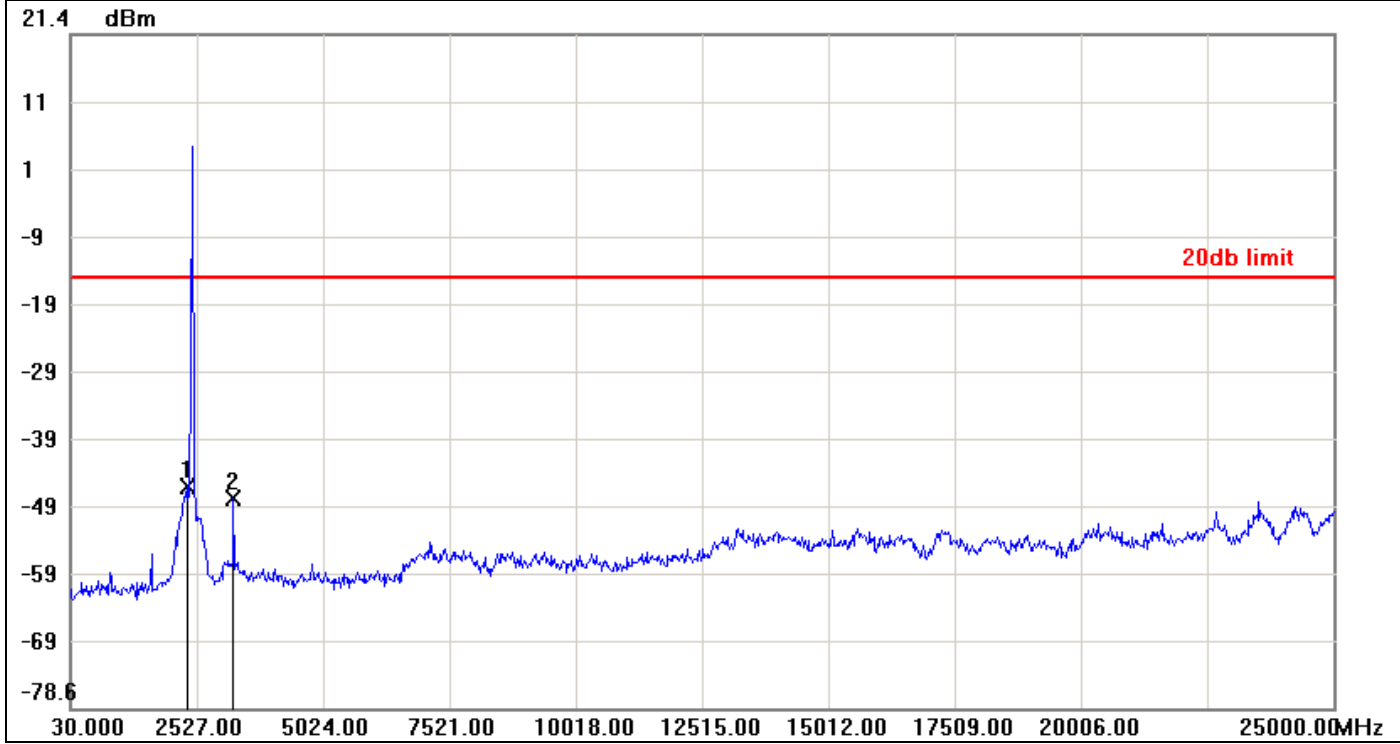

No.	Frequency(MHz)	Result(dBm)	Limit(dBm)	Margin(dBm)
1	2327.2400	-45.85	-14.66	-31.19
2	3251.1300	-47.42	-14.66	-32.76



**CH High**

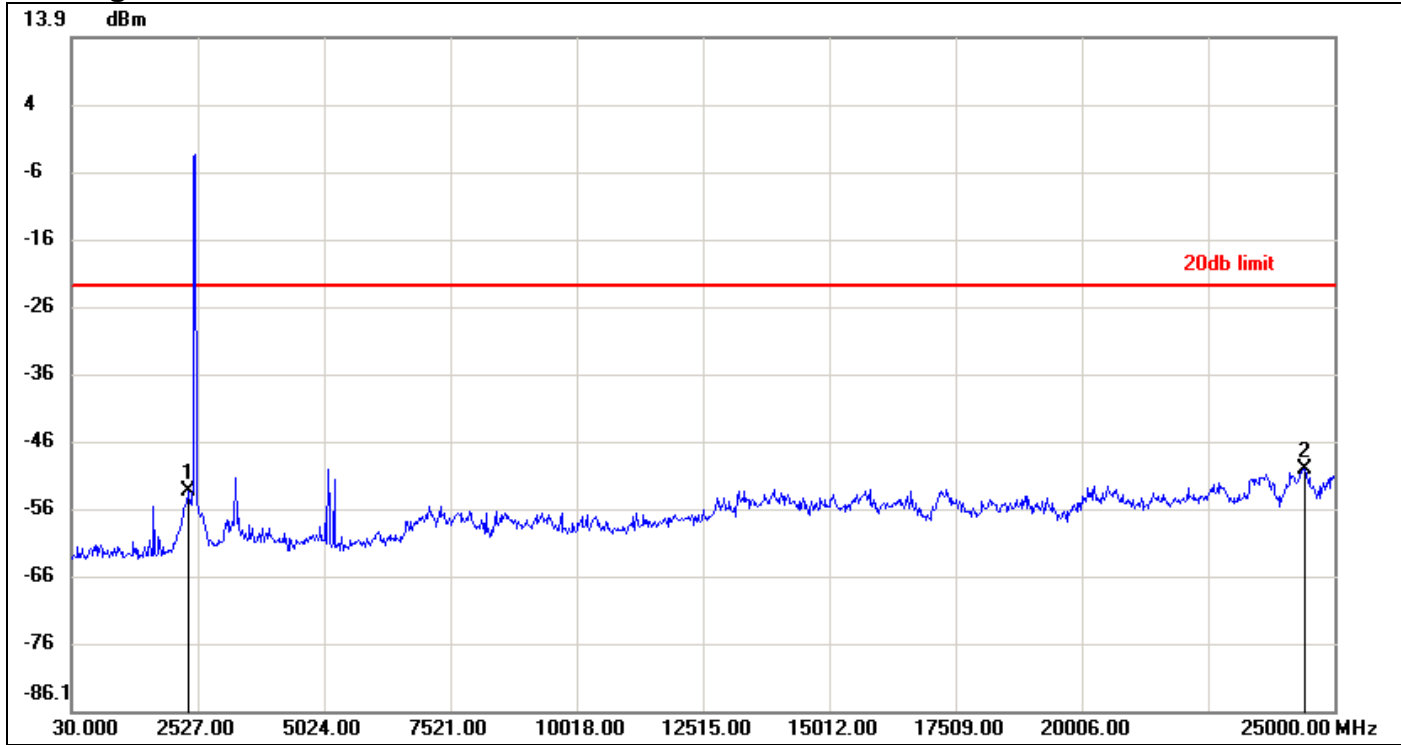

No.	Frequency(MHz)	Result(dBm)	Limit(dBm)	Margin(dBm)
1	2327.2400	-53.47	-23.04	-30.43
2	24425.6900	-50.14	-23.04	-27.10

**IEEE 802.11n HT 20 mode / Chain 1**

**CH Low**

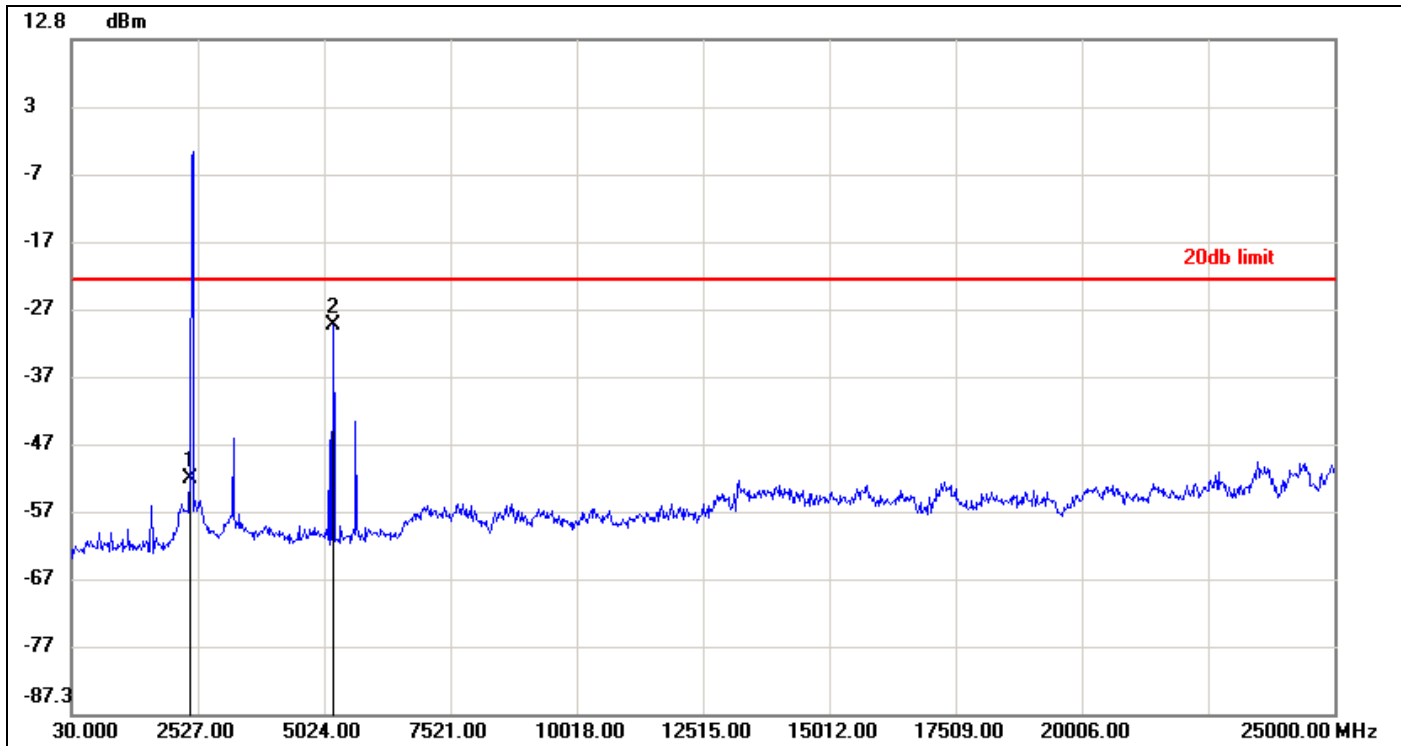

No.	Frequency(MHz)	Result(dBm)	Limit(dBm)	Margin(dBm)
1	2377.1800	-52.40	-22.78	-29.62
2	5198.7900	-29.57	-22.78	-6.79

**CH Mid**

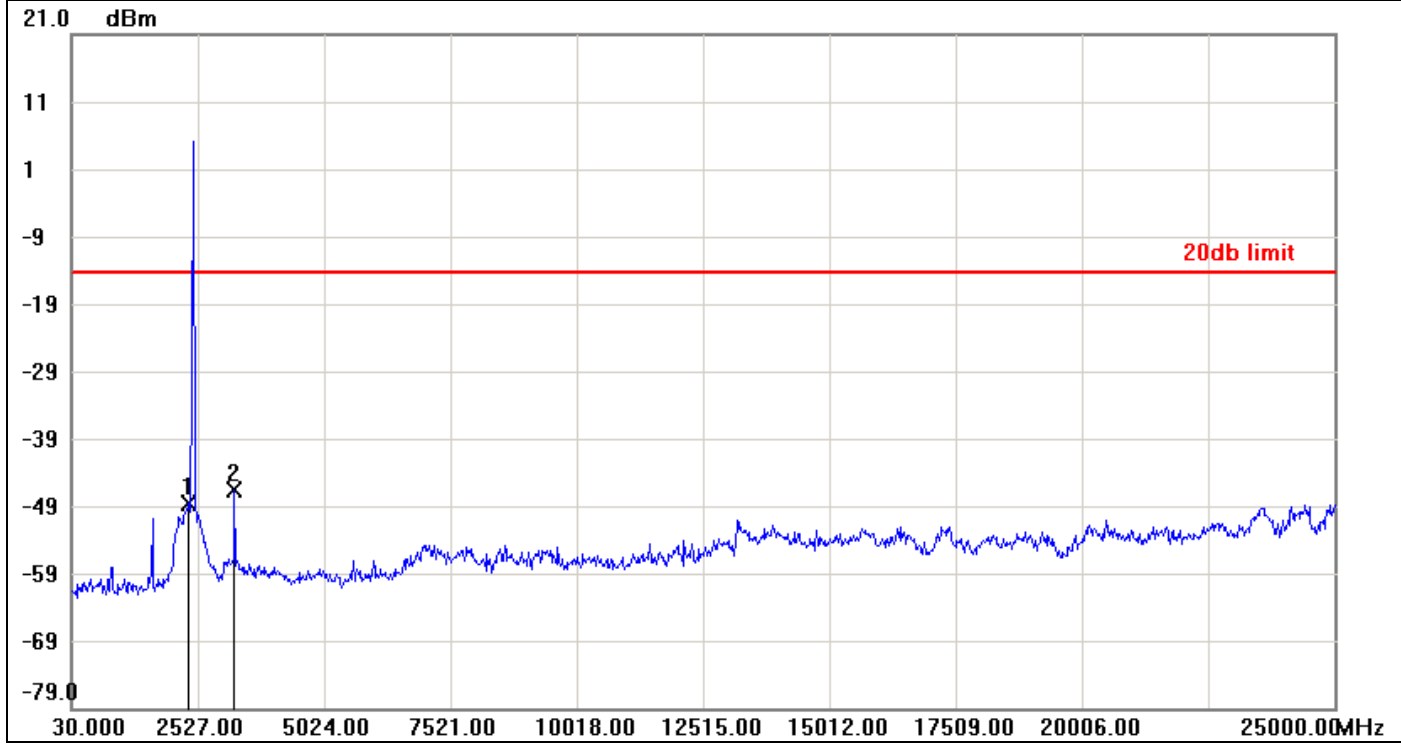

No.	Frequency(MHz)	Result(dBm)	Limit(dBm)	Margin(dBm)
1	2352.2100	-48.73	-14.26	-34.47
2	3251.1300	-46.51	-14.26	-32.25

**CH High**

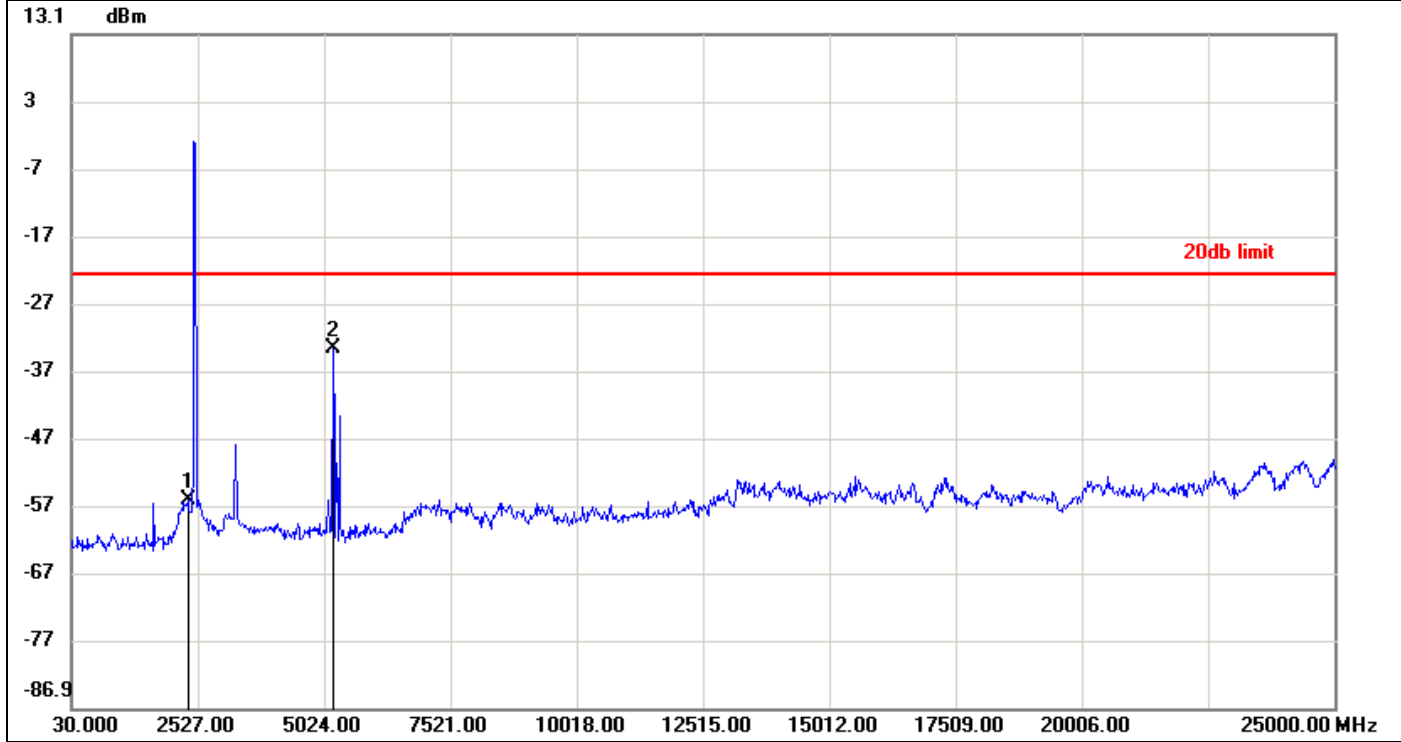

No.	Frequency(MHz)	Result(dBm)	Limit(dBm)	Margin(dBm)
1	2327.2400	-56.09	-22.63	-33.46
2	5198.7900	-33.64	-22.63	-11.01

**IEEE 802.11n HT 40 mode / Chain 0**

**CH Low**

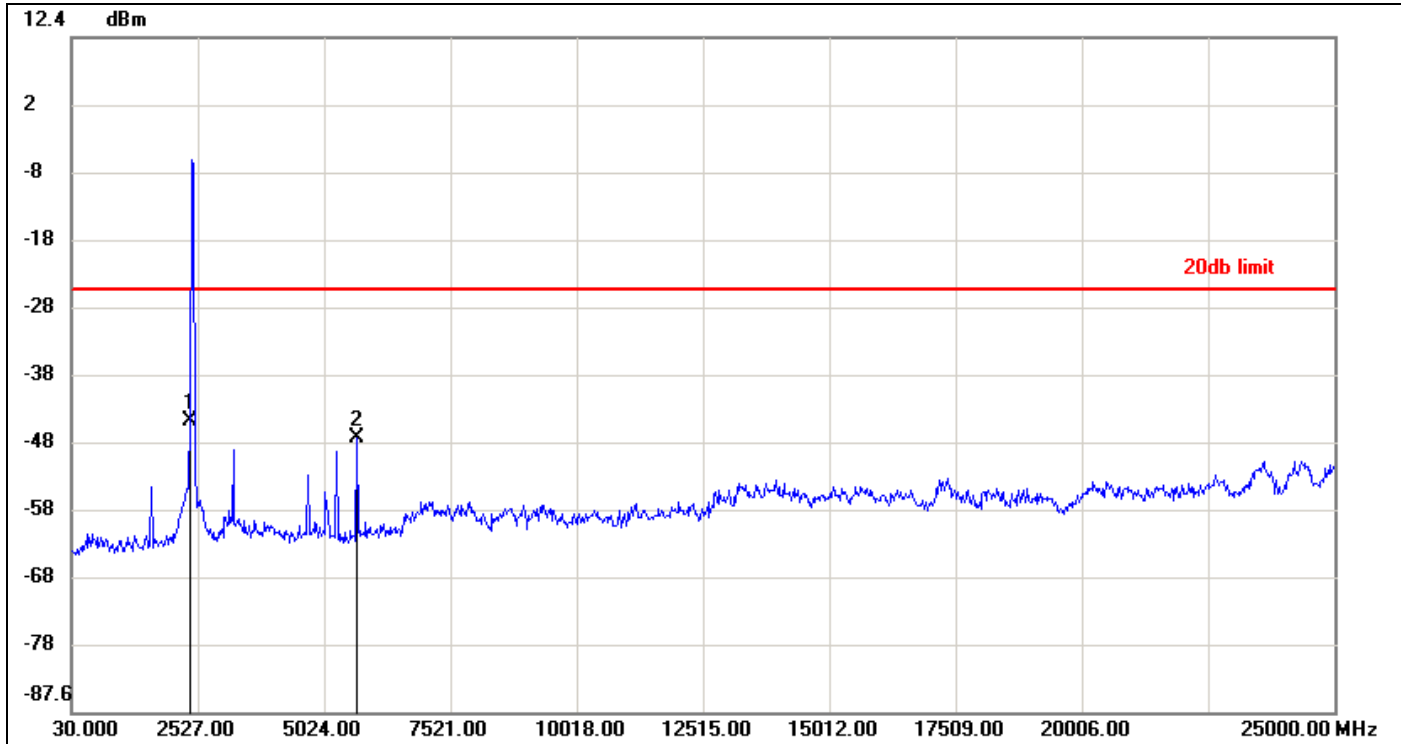

No.	Frequency(MHz)	Result(dBm)	Limit(dBm)	Margin(dBm)
1	2377.1800	-44.50	-25.03	-19.47
2	5673.2200	-47.00	-25.03	-21.97

**CH Mid**

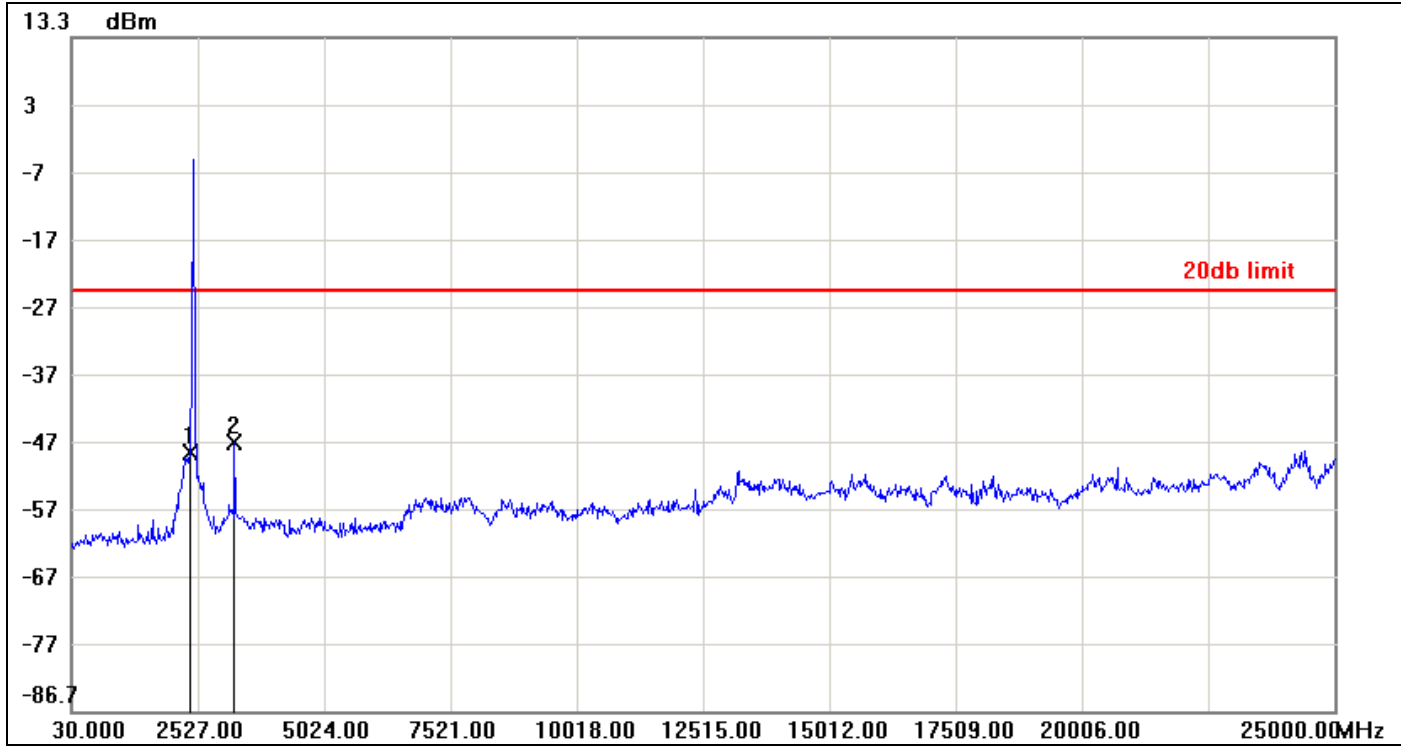

No.	Frequency(MHz)	Result(dBm)	Limit(dBm)	Margin(dBm)
1	2377.1800	-48.38	-24.32	-24.06
2	3251.1300	-46.97	-24.32	-22.65

**CH High**

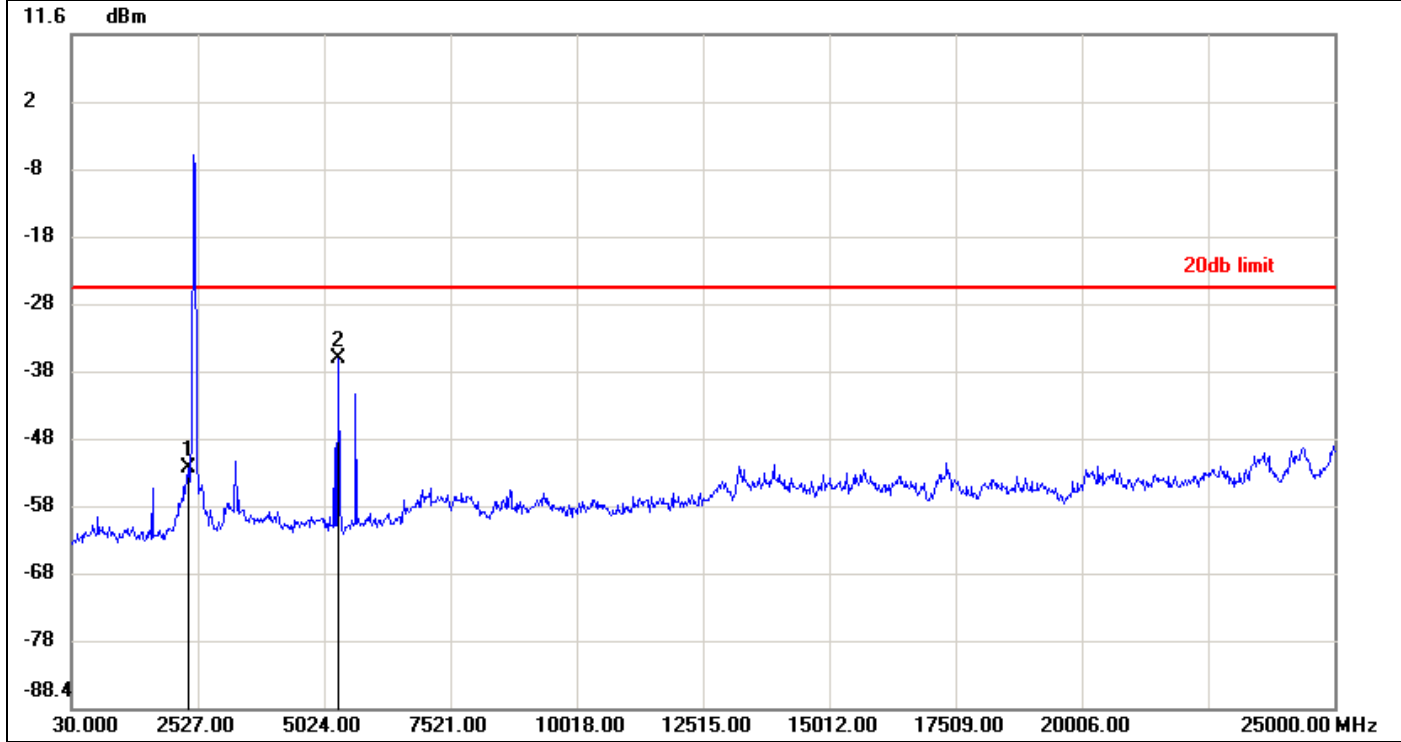

No.	Frequency(MHz)	Result(dBm)	Limit(dBm)	Margin(dBm)
1	2352.2100	-52.69	-26.09	-26.60
2	5298.6700	-36.44	-26.09	-10.35

**IEEE 802.11n HT 40 mode / Chain 1**

**CH Low**

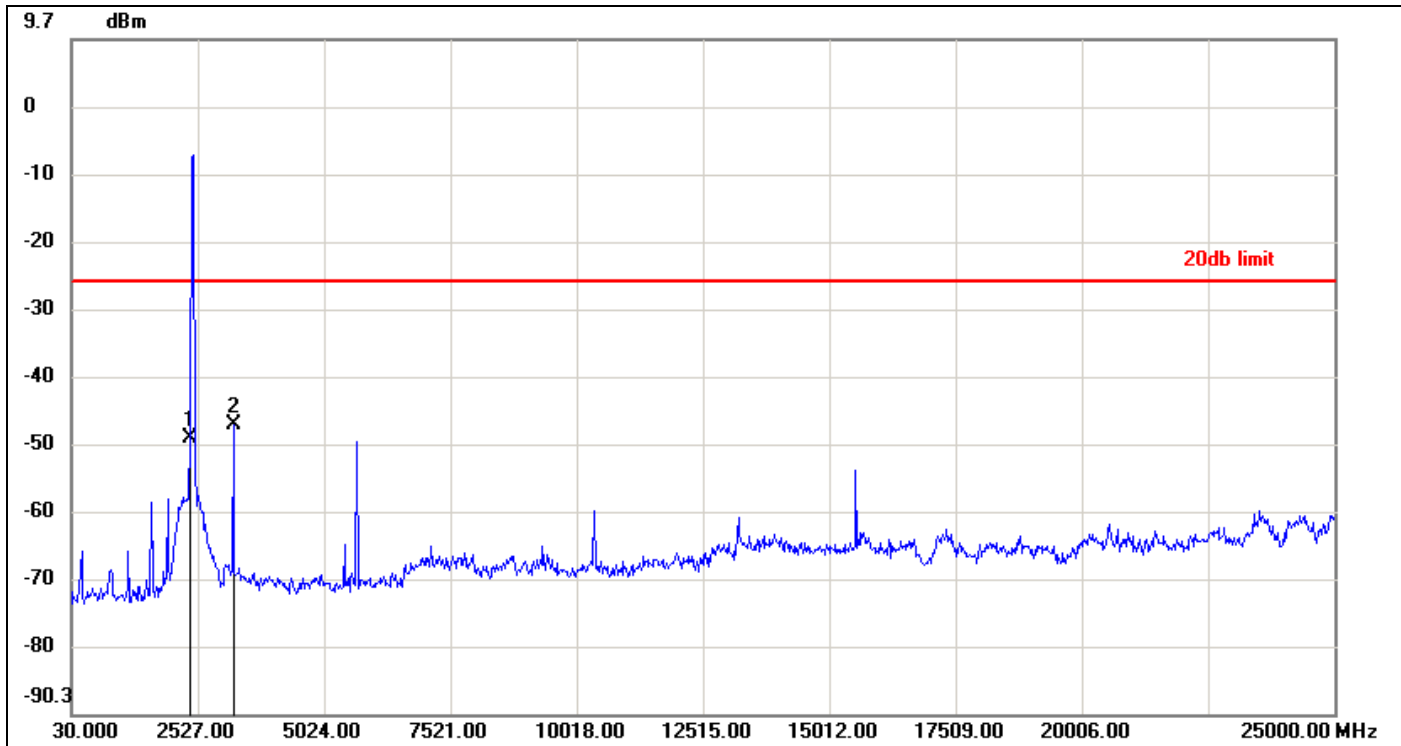

No.	Frequency(MHz)	Result(dBm)	Limit(dBm)	Margin(dBm)
1	2377.1800	-49.38	-26.16	-23.22
2	3226.1600	-47.49	-26.16	-21.33



**CH Mid**

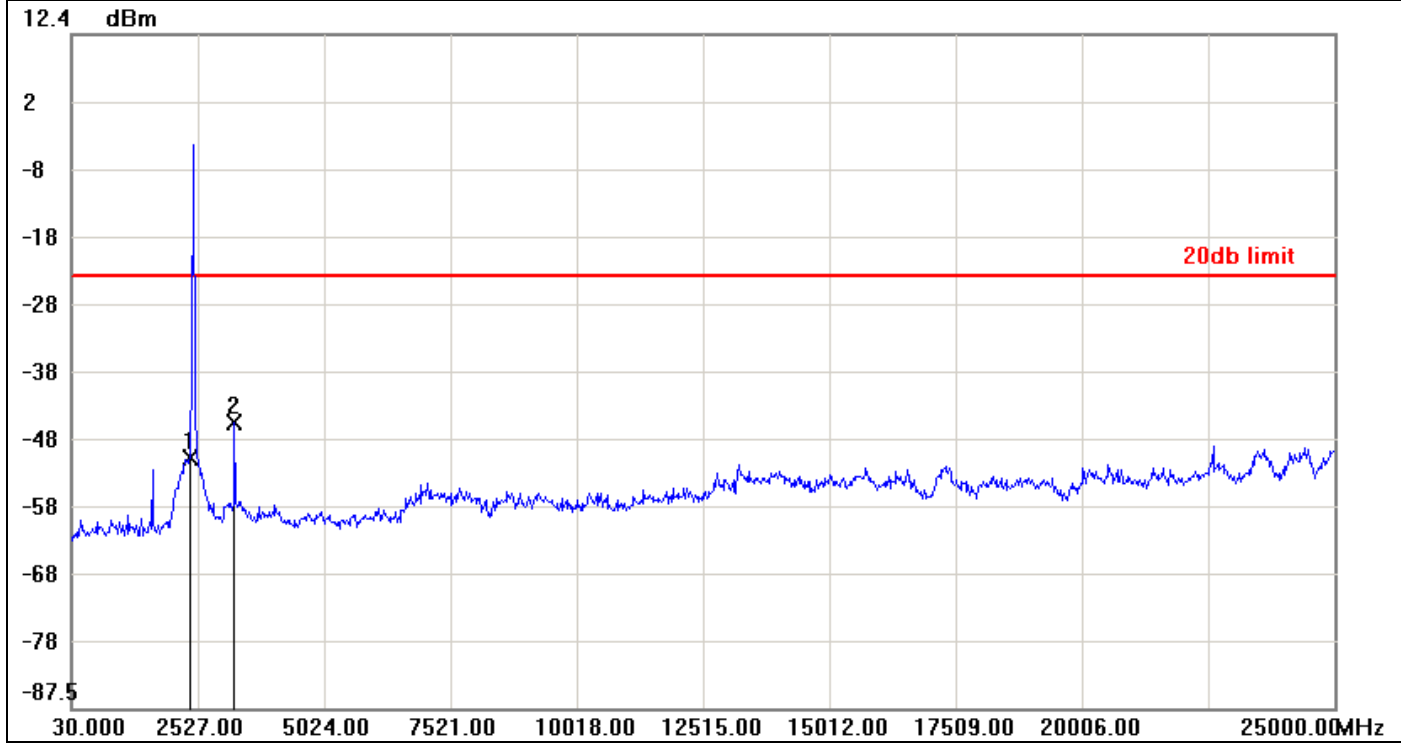

No.	Frequency(MHz)	Result(dBm)	Limit(dBm)	Margin(dBm)
1	2377.1800	-50.45	-23.50	-26.95
2	3251.1300	-45.17	-23.50	-21.67

**CH High**

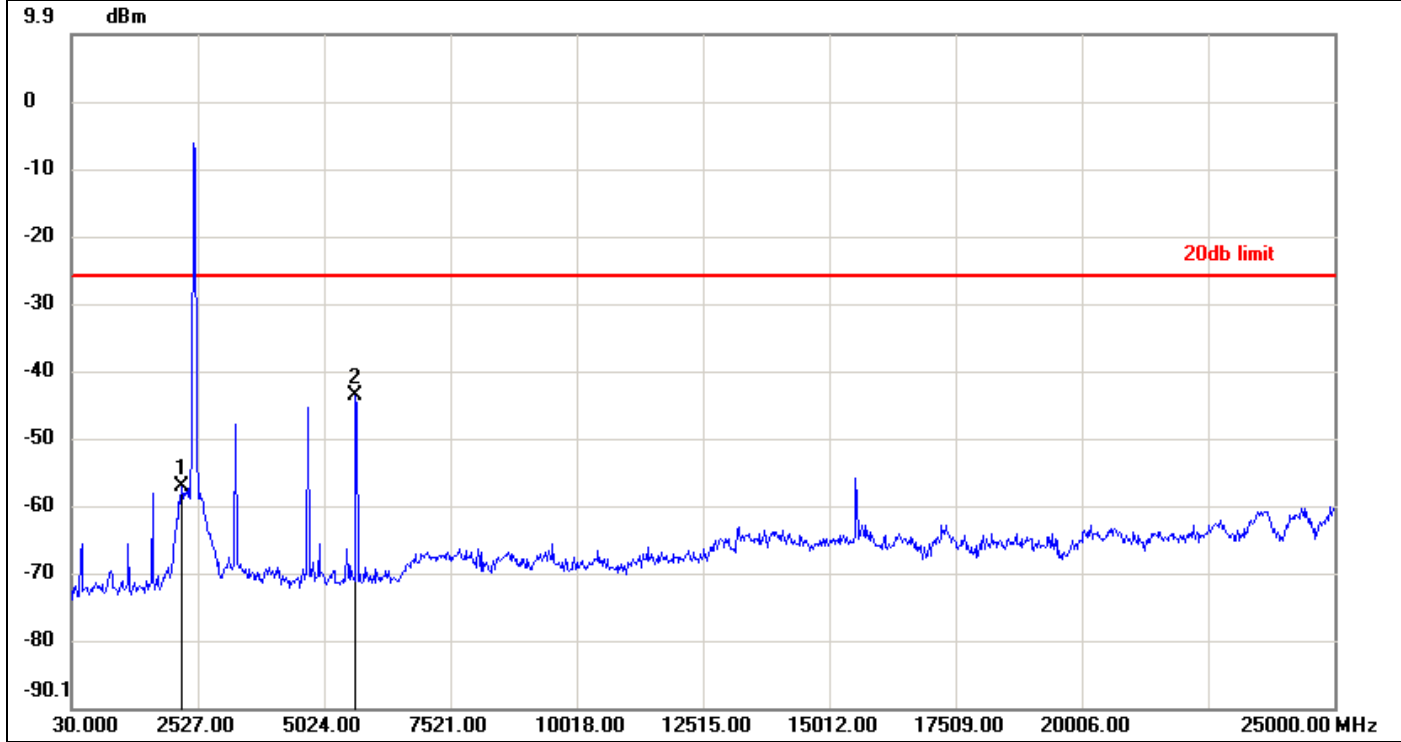

No.	Frequency(MHz)	Result(dBm)	Limit(dBm)	Margin(dBm)
1	2202.3900	-57.15	-25.96	-31.19
2	5648.2500	-43.77	-25.96	-17.81

## 7.7 RADIATED EMISSIONS

### LIMIT

1. According to §15.209(a), except as provided elsewhere in this Subpart, the emissions from an intentional radiator shall not exceed the field strength levels specified in the following table:

Frequency (MHz)	Field Strength (µV/m)	Measurement Distance (m)
0.009 - 0.490	2400/F(kHz)	300
0.490 - 1.705	24000/F(kHz)	30
1.705 – 30.0	30	30
30-88	100	3
88-216	150	3
216-960	200	3
Above 960	500	3

**Remark:** Except as provided in paragraph (g), fundamental emissions from intentional radiators operating under this Section shall not be located in the frequency bands 54-72 MHz, 76-88 MHz, 174-216 MHz or 470-806 MHz. However, operation within these frequency bands is permitted under other sections of this Part, e.g., Sections 15.231 and 15.241.

2. In the emission table above, the tighter limit applies at the band edges.

Frequency (MHz)	Field Strength (µV/m at 3-meter)	Field Strength (dBµV/m at 3-meter)
0.009 - 0.490	2400/F(kHz) +80	20LOG((2400/F(kHz))+80)
0.490 - 1.705	24000/F(kHz) +40	20LOG((24000/F(kHz))+40)
1.705 – 30.0	30	69.54
30-88	100	40
88-216	150	43.5
216-960	200	46
Above 960	500	54

**Test Configuration**

**9kHz ~ 30MHz**

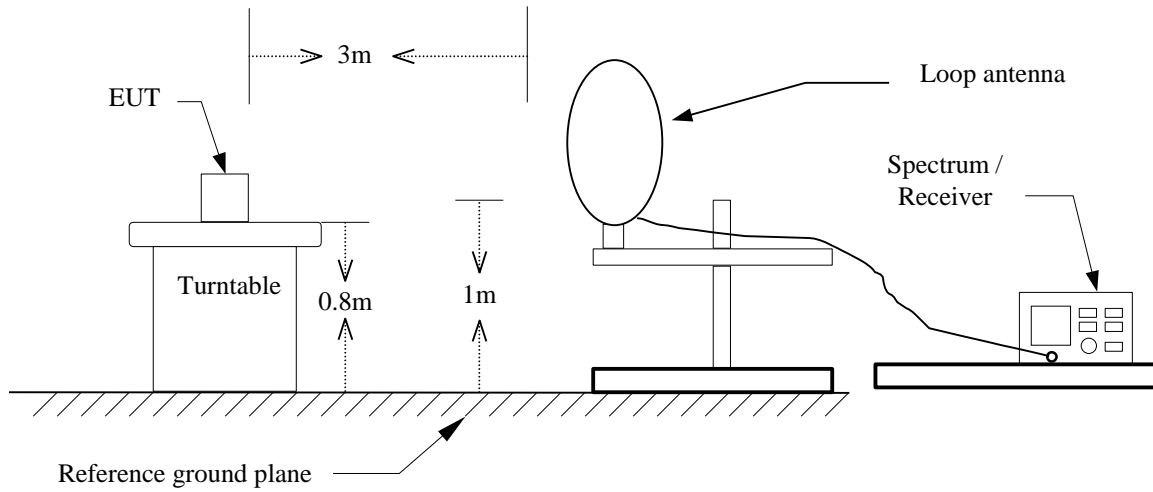

**30MHz ~ 1GHz**

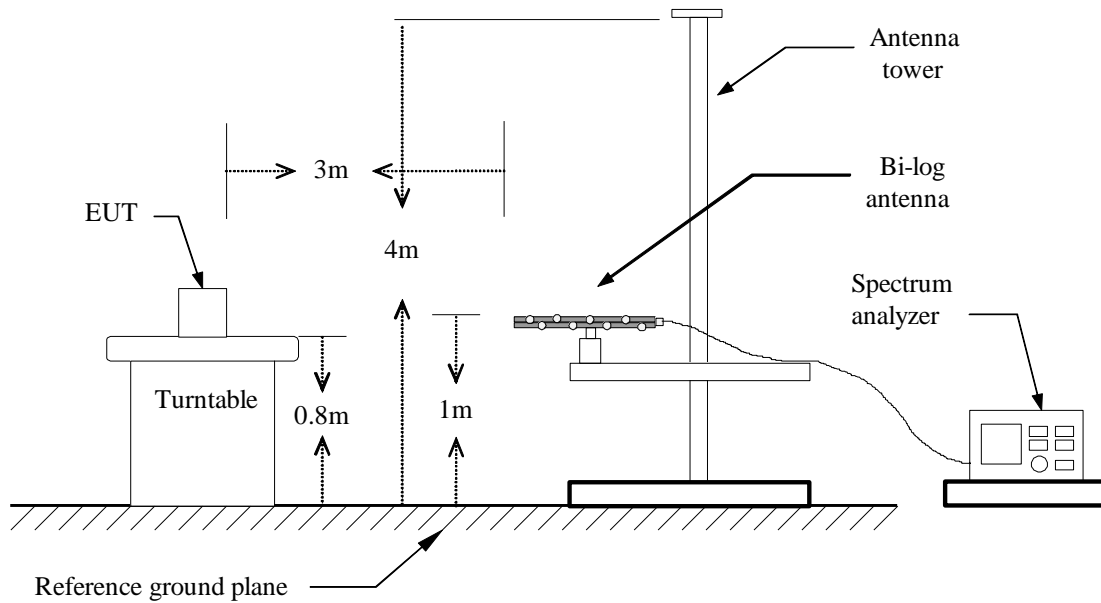

**Above 1 GHz**

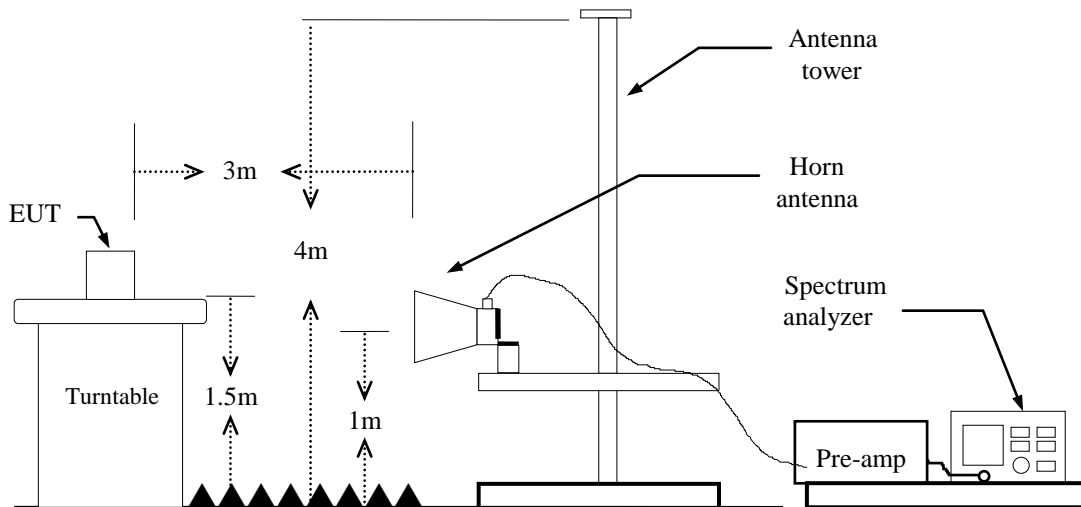

**TEST PROCEDURE**

1. The EUT is placed on a turntable, Above 1 GHz is 1.5m high and below 1 GHz is 0.8m high above ground plane.
2. The turntable shall be rotated for 360 degrees to determine the position of maximum emission level.
3. EUT is set 3m away from the receiving antenna, which is varied from 1m to 4m to find out the highest emissions.
4. Maximum procedure was performed on the six highest emissions to ensure EUT compliance.
5. And also, each emission was to be maximized by changing the polarization of receiving antenna both horizontal and vertical.
6. Set the spectrum analyzer in the following setting as:

Below 1GHz:

RBW=100kHz / VBW=300kHz / Sweep=AUTO

Above 1GHz:

(a) PEAK: RBW=VBW=3MHz / Sweep=AUTO

(b) AVERAGE: RBW=1MHz,  
 if duty cycle  $\geq$  98%, VBW=10Hz.

if duty cycle < 98% VBW=1/T.

IEEE 802.11b mode:  $\geq$  98%, VBW=10Hz

IEEE 802.11g mode:  $\geq$  98%, VBW=10Hz

IEEE 802.11n HT 20 MHz mode:  $\geq$  98%, VBW=10Hz

IEEE 802.11n HT 40 MHz mode:  $\geq$  98%=VBW 10Hz

7. Repeat above procedures until the measurements for all frequencies are complete.

**TEST RESULTS**

*No non-compliance noted.*

**Below 1GHz**

**Operation Mode:** Normal Link                      **Test Date:** November 6, 2015  
**Temperature:** 27°C                                      **Tested by:** Jason Lu  
**Humidity:** 53% RH                                      **Polarity:** Ver. / Hor.

Frequency (MHz)	Reading (dBuV)	Correction Factor (dB/m)	Result (dBuV/m)	Limit (dBuV/m)	Margin (dB)	Remark	Ant. Pol. (H/V)
56.1900	57.32	-21.71	35.61	40.00	-4.39	peak	V
99.8400	50.69	-19.07	31.62	43.50	-11.88	peak	V
166.7700	47.42	-16.69	30.73	43.50	-12.77	peak	V
375.3200	41.89	-12.29	29.60	46.00	-16.40	peak	V
624.6100	37.77	-7.17	30.60	46.00	-15.40	peak	V
874.8700	33.53	-3.49	30.04	46.00	-15.96	peak	V
36.7900	37.61	-12.95	24.66	40.00	-15.34	peak	H
132.8200	41.43	-15.68	25.75	43.50	-17.75	peak	H
192.9600	47.19	-16.18	31.01	43.50	-12.49	peak	H
375.3200	42.40	-12.29	30.11	46.00	-15.89	peak	H
673.1100	37.92	-6.34	31.58	46.00	-14.42	peak	H
749.7400	36.97	-4.93	32.04	46.00	-13.96	peak	H

**Remark:**

1. No emission found between lowest internal used/generated frequency to 30MHz (9kHz~30MHz)
2. Radiated emissions measured in frequency range from 30 MHz to 1000MHz were made with an instrument using peak/quasi-peak detector mode.
3. Measurements above show only up to 6 maximum emissions noted, or would be lesser, with " N/A " remark, if no specific emissions from the EUT are recorded (ie: margin>20dB from the applicable limit) and considered that's already beyond the background noise floor.
4. Margin (dB) = Result (dBuV/m) – Limit (dBuV/m).

**Above 1 GHz**

**Operation Mode:** TX / IEEE 802.11b / CH Low

**Test Date:** March 10, 2015

**Temperature:** 27°C

**Tested by:** Jason Lu

**Humidity:** 53% RH

**Polarity:** Ver. / Hor.

Frequency (MHz)	Reading (dBuV)	Correction Factor (dB/m)	Result (dBuV/m)	Limit (dBuV/m)	Margin (dB)	Remark	Ant. Pol. (H/V)
2054.000	53.58	-4.93	48.65	74.00	-25.35	peak	V
7235.000	43.85	10.64	54.49	74.00	-19.51	peak	V
7235.000	41.69	10.64	52.33	54.00	-1.67	AVG	V
N/A							
1956.000	52.81	-5.11	47.70	74.00	-26.30	peak	H
7240.000	39.29	10.65	49.94	74.00	-24.06	peak	H
7310.000	41.76	10.71	52.47	74.00	-21.53	peak	H
7310.000	39.10	10.71	49.81	54.00	-4.19	AVG	H
N/A							

**Remark:**

1. Measuring frequencies from 1 GHz to the 10th harmonic of highest fundamental frequency.
2. Radiated emissions measured in frequency above 1000MHz were made with an instrument using peak/average detector mode.
3. Average test would be performed if the peak result were greater than the average limit or as required by the applicant.
4. Data of measurement within this frequency range shown " --- " in the table above means the reading of emissions are attenuated more than 20dB below the permissible limits or the field strength is too small to be measured.
5. Measurements above show only up to 6 maximum emissions noted, or would be lesser, with " N/A " remark, if no specific emissions from the EUT are recorded (ie: margin>20dB from the applicable limit) and considered that's already beyond the background noise floor.
6. Margin (dB) = Remark result (dBuV/m) – Average limit (dBuV/m).

**Operation Mode:** TX / IEEE 802.11b / CH Mid

**Test Date:** March 10, 2015

**Temperature:** 27°C

**Tested by:** Jason Lu

**Humidity:** 53% RH

**Polarity:** Ver. / Hor.

Frequency (MHz)	Reading (dBuV)	Correction Factor (dB/m)	Result (dBuV/m)	Limit (dBuV/m)	Margin (dB)	Remark	Ant. Pol. (H/V)
1624.000	51.58	-6.87	44.71	74.00	-29.29	peak	V
3250.000	50.55	-1.51	49.04	74.00	-24.96	peak	V
7310.000	43.65	10.71	54.36	74.00	-19.64	peak	V
7310.000	42.26	10.71	52.97	54.00	-1.03	AVG	V
N/A							
1678.000	51.84	-6.59	45.25	74.00	-28.75	peak	H
7310.000	41.76	10.71	52.47	74.00	-21.53	peak	H
7310.000	39.10	10.71	49.81	54.00	-4.19	AVG	H
N/A							

**Remark:**

1. Measuring frequencies from 1 GHz to the 10th harmonic of highest fundamental frequency.
2. Radiated emissions measured in frequency above 1000MHz were made with an instrument using peak/average detector mode.
3. Average test would be performed if the peak result were greater than the average limit or as required by the applicant.
4. Data of measurement within this frequency range shown " --- " in the table above means the reading of emissions are attenuated more than 20dB below the permissible limits or the field strength is too small to be measured.
5. Measurements above show only up to 6 maximum emissions noted, or would be lesser, with " N/A " remark, if no specific emissions from the EUT are recorded (ie: margin>20dB from the applicable limit) and considered that's already beyond the background noise floor.
6. Margin (dB) = Remark result (dBuV/m) – Average limit (dBuV/m).



**Operation Mode:** TX / IEEE 802.11b / CH High

**Test Date:** March 10, 2015

**Temperature:** 27°C

**Tested by:** Jason Lu

**Humidity:** 53% RH

**Polarity:** Ver. / Hor.

Frequency (MHz)	Reading (dBuV)	Correction Factor (dB/m)	Result (dBuV/m)	Limit (dBuV/m)	Margin (dB)	Remark	Ant. Pol. (H/V)
54.33	-4.42	49.91	74.00	-24.09	peak	peak	V
3285.000	50.72	-1.43	49.29	74.00	-24.71	peak	V
7385.000	45.79	10.79	56.58	74.00	-17.42	peak	V
7385.000	42.22	10.79	53.01	54.00	-0.99	AVG	V
N/A							
1716.000	49.47	-6.39	43.08	74.00	-30.92	peak	H
7385.000	40.54	10.79	51.33	74.00	-22.67	peak	H
N/A							

**Remark:**

1. Measuring frequencies from 1 GHz to the 10th harmonic of highest fundamental frequency.
2. Radiated emissions measured in frequency above 1000MHz were made with an instrument using peak/average detector mode.
3. Average test would be performed if the peak result were greater than the average limit or as required by the applicant.
4. Data of measurement within this frequency range shown “ --- ” in the table above means the reading of emissions are attenuated more than 20dB below the permissible limits or the field strength is too small to be measured.
5. Measurements above show only up to 6 maximum emissions noted, or would be lesser, with “ N/A ” remark, if no specific emissions from the EUT are recorded (ie: margin>20dB from the applicable limit) and considered that's already beyond the background noise floor.
6. Margin (dB) = Remark result (dBuV/m) – Average limit (dBuV/m).

**Operation Mode:** TX / IEEE 802.11g / CH Low

**Test Date:** March 10, 2015

**Temperature:** 27°C

**Tested by:** Jason Lu

**Humidity:** 53% RH

**Polarity:** Ver. / Hor.

Frequency (MHz)	Reading (dBuV)	Correction Factor (dB/m)	Result (dBuV/m)	Limit (dBuV/m)	Margin (dB)	Remark	Ant. Pol. (H/V)
1946.000	52.05	-5.17	46.88	74.00	-27.12	peak	V
3215.000	51.79	-1.59	50.20	74.00	-23.80	peak	V
N/A							
1668.000	50.41	-6.64	43.77	74.00	-30.23	peak	H
N/A							

**Remark:**

1. Measuring frequencies from 1 GHz to the 10th harmonic of highest fundamental frequency.
2. Radiated emissions measured in frequency above 1000MHz were made with an instrument using peak/average detector mode.
3. Average test would be performed if the peak result were greater than the average limit or as required by the applicant.
4. Data of measurement within this frequency range shown " --- " in the table above means the reading of emissions are attenuated more than 20dB below the permissible limits or the field strength is too small to be measured.
5. Measurements above show only up to 6 maximum emissions noted, or would be lesser, with " N/A " remark, if no specific emissions from the EUT are recorded (ie: margin>20dB from the applicable limit) and considered that's already beyond the background noise floor.
6. Margin (dB) = Remark result (dBuV/m) – Average limit (dBuV/m).

**Operation Mode:** TX / IEEE 802.11g / CH Mid

**Test Date:** March 10, 2015

**Temperature:** 27°C

**Tested by:** Jason Lu

**Humidity:** 53% RH

**Polarity:** Ver. / Hor.

Frequency (MHz)	Reading (dBuV)	Correction Factor (dB/m)	Result (dBuV/m)	Limit (dBuV/m)	Margin (dB)	Remark	Ant. Pol. (H/V)
2132.000	55.56	-4.80	50.76	74.00	-23.24	peak	V
7315.000	42.91	10.72	53.63	74.00	-20.37	peak	V
7315.000	42.19	10.72	52.91	54.00	-1.09	AVG	V
N/A							
1496.000	52.44	-7.55	44.89	74.00	-29.11	peak	H
7310.000	49.54	10.71	60.25	74.00	-13.75	peak	H
7310.000	40.10	10.71	50.81	54.00	-3.19	AVG	H
N/A							

**Remark:**

1. Measuring frequencies from 1 GHz to the 10th harmonic of highest fundamental frequency.
2. Radiated emissions measured in frequency above 1000MHz were made with an instrument using peak/average detector mode.
3. Average test would be performed if the peak result were greater than the average limit or as required by the applicant.
4. Data of measurement within this frequency range shown “ --- ” in the table above means the reading of emissions are attenuated more than 20dB below the permissible limits or the field strength is too small to be measured.
5. Measurements above show only up to 6 maximum emissions noted, or would be lesser, with “ N/A ” remark, if no specific emissions from the EUT are recorded (ie: margin>20dB from the applicable limit) and considered that's already beyond the background noise floor.
6. Margin (dB) = Remark result (dBuV/m) – Average limit (dBuV/m).

**Operation Mode:** TX / IEEE 802.11g / CH High

**Test Date:** March 10, 2015

**Temperature:** 27°C

**Tested by:** Jason Lu

**Humidity:** 53% RH

**Polarity:** Ver. / Hor.

Frequency (MHz)	Reading (dBuV)	Correction Factor (dB/m)	Result (dBuV/m)	Limit (dBuV/m)	Margin (dB)	Remark	Ant. Pol. (H/V)
1488.000	51.66	-7.58	44.08	74.00	-29.92	peak	V
3285.000	49.06	-1.43	47.63	74.00	-26.37	peak	V
7385.000	43.16	10.79	53.95	74.00	-20.05	peak	V
7385.000	33.89	10.79	44.68	54.00	-9.32	AVG	V
N/A							
1448.000	50.83	-7.76	43.07	74.00	-30.93	peak	H
7385.000	37.55	10.79	48.34	74.00	-25.66	peak	H
N/A							

**Remark:**

1. Measuring frequencies from 1 GHz to the 10th harmonic of highest fundamental frequency.
2. Radiated emissions measured in frequency above 1000MHz were made with an instrument using peak/average detector mode.
3. Average test would be performed if the peak result were greater than the average limit or as required by the applicant.
4. Data of measurement within this frequency range shown " --- " in the table above means the reading of emissions are attenuated more than 20dB below the permissible limits or the field strength is too small to be measured.
5. Measurements above show only up to 6 maximum emissions noted, or would be lesser, with " N/A " remark, if no specific emissions from the EUT are recorded (ie: margin>20dB from the applicable limit) and considered that's already beyond the background noise floor.
6. Margin (dB) = Remark result (dBuV/m) – Average limit (dBuV/m).

**Operation Mode:** TX / IEEE 802.11n HT 20 mode / CH Low

**Test Date:** March 10, 2015

**Temperature:** 27°C

**Tested by:** Jason Lu

**Humidity:** 53% RH

**Polarity:** Ver. / Hor.

Frequency (MHz)	Reading (dBuV)	Correction Factor (dB/m)	Result (dBuV/m)	Limit (dBuV/m)	Margin (dB)	Remark	Ant. Pol. (H/V)
1486.000	51.73	-7.59	44.14	74.00	-29.86	peak	V
3215.000	49.96	-1.59	48.37	74.00	-25.63	peak	V
N/A							
1608.000	50.40	-6.96	43.44	74.00	-30.56	peak	H
5305.000	40.14	4.88	45.02	74.00	-28.98	peak	H
N/A							

**Remark:**

1. Measuring frequencies from 1 GHz to the 10th harmonic of highest fundamental frequency.
2. Radiated emissions measured in frequency above 1000MHz were made with an instrument using peak/average detector mode.
3. Average test would be performed if the peak result were greater than the average limit or as required by the applicant.
4. Data of measurement within this frequency range shown “ --- ” in the table above means the reading of emissions are attenuated more than 20dB below the permissible limits or the field strength is too small to be measured.
5. Measurements above show only up to 6 maximum emissions noted, or would be lesser, with “ N/A ” remark, if no specific emissions from the EUT are recorded (ie: margin>20dB from the applicable limit) and considered that's already beyond the background noise floor.
6. Margin (dB) = Remark result (dBuV/m) – Average limit (dBuV/m).

**Operation Mode:** TX / IEEE 802.11n HT 20 mode / CH Mid

**Test Date:** March 10, 2015

**Temperature:** 27°C

**Tested by:** Jason Lu

**Humidity:** 53% RH

**Polarity:** Ver. / Hor.

Frequency (MHz)	Reading (dBuV)	Correction Factor (dB/m)	Result (dBuV/m)	Limit (dBuV/m)	Margin (dB)	Remark	Ant. Pol. (H/V)
1952.000	53.20	-5.13	48.07	74.00	-25.93	peak	V
3250.000	51.58	-1.51	50.07	74.00	-23.93	peak	V
7305.000	48.46	10.71	59.17	74.00	-14.83	peak	V
7305.000	37.86	10.71	48.57	54.00	-5.43	AVG	V
N/A							
1952.000	52.29	-5.13	47.16	74.00	-26.84	peak	H
7320.000	45.28	10.72	56.00	74.00	-18.00	peak	H
7320.000	34.01	10.72	44.73	54.00	-9.27	AVG	H
N/A							

**Remark:**

1. Measuring frequencies from 1 GHz to the 10th harmonic of highest fundamental frequency.
2. Radiated emissions measured in frequency above 1000MHz were made with an instrument using peak/average detector mode.
3. Average test would be performed if the peak result were greater than the average limit or as required by the applicant.
4. Data of measurement within this frequency range shown “ --- ” in the table above means the reading of emissions are attenuated more than 20dB below the permissible limits or the field strength is too small to be measured.
5. Measurements above show only up to 6 maximum emissions noted, or would be lesser, with “ N/A ” remark, if no specific emissions from the EUT are recorded (ie: margin>20dB from the applicable limit) and considered that's already beyond the background noise floor.
6. Margin (dB) = Remark result (dBuV/m) – Average limit (dBuV/m).

**Operation Mode:** TX / IEEE 802.11n HT 20 mode / CH High

**Test Date:** March 10, 2015

**Temperature:** 27°C

**Tested by:** Jason Lu

**Humidity:** 53% RH

**Polarity:** Ver. / Hor.

Frequency (MHz)	Reading (dBuV)	Correction Factor (dB/m)	Result (dBuV/m)	Limit (dBuV/m)	Margin (dB)	Remark	Ant. Pol. (H/V)
1946.000	53.65	-5.17	48.48	74.00	-25.52	peak	V
3285.000	47.68	-1.43	46.25	74.00	-27.75	peak	V
N/A							
1486.000	51.39	-7.59	43.80	74.00	-30.20	peak	H
3285.000	47.21	-1.43	45.78	74.00	-28.22	peak	H
N/A							

**Remark:**

1. Measuring frequencies from 1 GHz to the 10th harmonic of highest fundamental frequency.
2. Radiated emissions measured in frequency above 1000MHz were made with an instrument using peak/average detector mode.
3. Average test would be performed if the peak result were greater than the average limit or as required by the applicant.
4. Data of measurement within this frequency range shown " --- " in the table above means the reading of emissions are attenuated more than 20dB below the permissible limits or the field strength is too small to be measured.
5. Measurements above show only up to 6 maximum emissions noted, or would be lesser, with " N/A " remark, if no specific emissions from the EUT are recorded (ie: margin>20dB from the applicable limit) and considered that's already beyond the background noise floor.
6. Margin (dB) = Remark result (dBuV/m) – Average limit (dBuV/m).

**Operation Mode:** TX / IEEE 802.11n HT 40 mode  
/ CH Low  
**Temperature:** 27°C  
**Humidity:** 53% RH

**Test Date:** March 10, 2015  
**Tested by:** Jason Lu  
**Polarity:** Ver. / Hor.

Frequency (MHz)	Reading (dBuV)	Correction Factor (dB/m)	Result (dBuV/m)	Limit (dBuV/m)	Margin (dB)	Remark	Ant. Pol. (H/V)
1490.000	53.02	-7.57	45.45	74.00	-28.55	peak	V
3230.000	50.71	-1.56	49.15	74.00	-24.85	peak	V
N/A							
1952.000	53.68	-5.13	48.55	74.00	-25.45	peak	H
3230.000	46.46	-1.56	44.90	74.00	-29.10	peak	H
N/A							

**Remark:**

1. Measuring frequencies from 1 GHz to the 10th harmonic of highest fundamental frequency.
2. Radiated emissions measured in frequency above 1000MHz were made with an instrument using peak/average detector mode.
3. Average test would be performed if the peak result were greater than the average limit or as required by the applicant.
4. Data of measurement within this frequency range shown “ --- ” in the table above means the reading of emissions are attenuated more than 20dB below the permissible limits or the field strength is too small to be measured.
5. Measurements above show only up to 6 maximum emissions noted, or would be lesser, with “ N/A ” remark, if no specific emissions from the EUT are recorded (ie: margin>20dB from the applicable limit) and considered that's already beyond the background noise floor.
6. Margin (dB) = Remark result (dBuV/m) – Average limit (dBuV/m).



**Operation Mode:** TX / IEEE 802.11n HT 40 mode  
/ CH Mid

**Test Date:** March 10, 2015

**Temperature:** 27°C

**Tested by:** Jason Lu

**Humidity:** 53% RH

**Polarity:** Ver. / Hor.

Frequency (MHz)	Reading (dBuV)	Correction Factor (dB/m)	Result (dBuV/m)	Limit (dBuV/m)	Margin (dB)	Remark	Ant. Pol. (H/V)
1788.000	49.79	-6.00	43.79	74.00	-30.21	peak	V
3250.000	52.86	-1.51	51.35	74.00	-22.65	peak	V
N/A							
1670.000	50.52	-6.63	43.89	74.00	-30.11	peak	H
N/A							

**Remark:**

1. Measuring frequencies from 1 GHz to the 10th harmonic of highest fundamental frequency.
2. Radiated emissions measured in frequency above 1000MHz were made with an instrument using peak/average detector mode.
3. Average test would be performed if the peak result were greater than the average limit or as required by the applicant.
4. Data of measurement within this frequency range shown “ --- ” in the table above means the reading of emissions are attenuated more than 20dB below the permissible limits or the field strength is too small to be measured.
5. Measurements above show only up to 6 maximum emissions noted, or would be lesser, with “ N/A ” remark, if no specific emissions from the EUT are recorded (ie: margin>20dB from the applicable limit) and considered that's already beyond the background noise floor.
6.  $Margin (dB) = Remark\ result (dBuV/m) - Average\ limit (dBuV/m).$

**Operation Mode:** TX / IEEE 802.11n HT 40 mode  
/ CH High

**Test Date:** March 10, 2015

**Temperature:** 27°C

**Tested by:** Jason Lu

**Humidity:** 53% RH

**Polarity:** Ver. / Hor.

Frequency (MHz)	Reading (dBuV)	Correction Factor (dB/m)	Result (dBuV/m)	Limit (dBuV/m)	Margin (dB)	Remark	Ant. Pol. (H/V)
1638.000	54.76	-6.80	47.96	74.00	-26.04	peak	V
3270.000	51.37	-1.46	49.91	74.00	-24.09	peak	V
N/A							
1752.000	50.43	-6.19	44.24	74.00	-29.76	peak	H
3270.000	47.94	-1.46	46.48	74.00	-27.52	peak	H
N/A							

**Remark:**

1. Measuring frequencies from 1 GHz to the 10th harmonic of highest fundamental frequency.
2. Radiated emissions measured in frequency above 1000MHz were made with an instrument using peak/average detector mode.
3. Average test would be performed if the peak result were greater than the average limit or as required by the applicant.
4. Data of measurement within this frequency range shown " --- " in the table above means the reading of emissions are attenuated more than 20dB below the permissible limits or the field strength is too small to be measured.
5. Measurements above show only up to 6 maximum emissions noted, or would be lesser, with " N/A " remark, if no specific emissions from the EUT are recorded (ie: margin>20dB from the applicable limit) and considered that's already beyond the background noise floor.
6.  $Margin (dB) = Remark\ result (dBuV/m) - Average\ limit (dBuV/m).$

## 7.8 POWERLINE CONDUCTED EMISSIONS

### LIMIT

According to §15.207(a), except as shown in paragraphs (b) and (c) of this section, for an intentional radiator that is designed to be connected to the public utility (AC) power line, the radio frequency voltage that is conducted back onto the AC power line on any frequency or frequencies within the band 150 kHz to 30 MHz shall not exceed the limits in the following table, as measured using a 50  $\mu$ H/50 ohms line impedance stabilization network (LISN). Compliance with the provisions of this paragraph shall be based on the measurement of the radio frequency voltage between each power line and ground at the power terminal. The lower limit applies at the boundary between the frequency ranges.

Frequency Range (MHz)	Limits (dB $\mu$ V)	
	Quasi-peak	Average
0.15 to 0.50	66 to 56*	56 to 46*
0.50 to 5	56	46
5 to 30	60	50

\* Decreases with the logarithm of the frequency.

### Test Configuration

See test photographs attached in Appendix II for the actual connections between EUT and support equipment.

### TEST PROCEDURE

1. The EUT was placed on a table, which is 0.8m above ground plane.
2. Maximum procedure was performed on the six highest emissions to ensure EUT compliance.
3. Repeat above procedures until all frequency measured were complete.

## **TEST RESULTS**

The initial step in collecting conducted data is a spectrum analyzer peak scan of the measurement range. Significant peaks are then marked as shown on the following data page, and these signals are then quasi-peaked.

### **Test Data**

**Operation Mode:** Normal Link                      **Test Date:** November 10, 2015  
**Temperature:** 24°C                                      **Tested by:** Dennis Li  
**Humidity:** 50% RH

Freq. (MHz)	QP Reading (dBuV)	AV Reading (dBuV)	Corr. factor (dB/m)	QP Result (dBuV/m)	AV Result (dBuV/m)	QP Limit (dBuV)	AV Limit (dBuV)	QP Margin (dB)	AV Margin (dB)	Note
0.1500	43.79	41.85	9.69	53.48	51.54	66.00	56.00	-12.52	-4.46	L1
0.1980	34.70	32.41	9.68	44.38	42.09	63.69	53.69	-19.31	-11.60	L1
0.2460	43.80	38.82	9.68	53.48	48.50	61.89	51.89	-8.41	-3.39	L1
1.1380	28.79	26.84	10.41	39.20	37.25	56.00	46.00	-16.80	-8.75	L1
5.1180	31.61	29.11	9.85	41.46	38.96	60.00	50.00	-18.54	-11.04	L1
7.2020	30.86	27.94	9.88	40.74	37.82	60.00	50.00	-19.26	-12.18	L1
0.1539	44.37	42.64	9.64	54.01	52.28	65.78	55.79	-11.77	-3.51	L2
0.2020	37.13	35.41	9.64	46.77	45.05	63.52	53.53	-16.75	-8.48	L2
0.4580	27.16	24.57	9.73	36.89	34.30	56.73	46.73	-19.84	-12.43	L2
0.9460	27.81	26.21	10.41	38.22	36.62	56.00	46.00	-17.78	-9.38	L2
1.1380	28.31	24.58	10.37	38.68	34.95	56.00	46.00	-17.32	-11.05	L2
5.8700	31.00	28.94	9.83	40.83	38.77	60.00	50.00	-19.17	-11.23	L2

**Remark:**

1. Measuring frequencies from 0.15 MHz to 30MHz.
2. The emissions measured in frequency range from 0.15 MHz to 30MHz were made with an instrument using Quasi-peak detector and average detector.
3. The IF bandwidth of SPA between 0.15MHz and 30MHz was 10 kHz; the IF bandwidth of Test Receiver between 0.15MHz and 30MHz was 9 kHz;
4. L1 = Line One (Live Line) / L2 = Line Two (Neutral Line)

### Test Plots

#### Conducted emissions (Line 1)

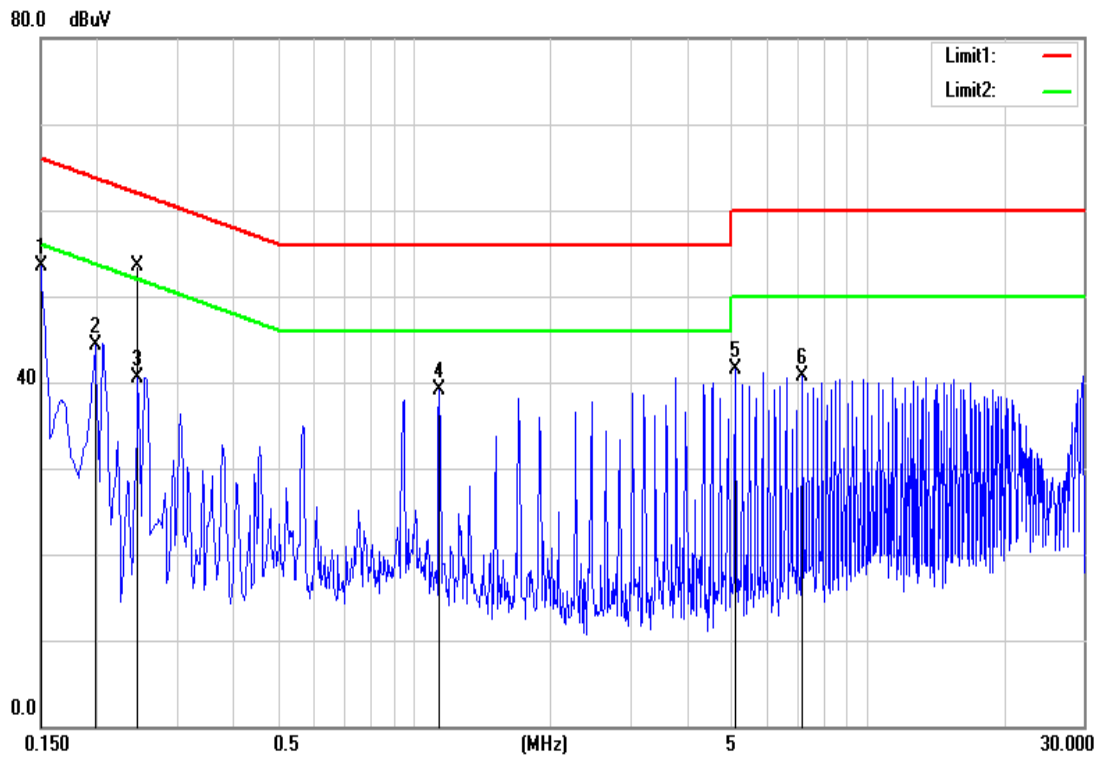

#### Conducted emissions (Line 2)

