

FCC 47 CFR PART 15 SUBPART E

TEST REPORT

For

VigorAP 902 Dual Band 11ac AP

Model: VigorAP 902

Trade Name: DrayTek

Issued to

DrayTek Corp.
No.26 Fu Shing Rd., HuKou County,Hsinchu Industrial
Park,Hsinchu,Taiwan 303 R.O.C

Issued by

Compliance Certification Services Inc.
No.11, Wugong 6th Rd., Wugu Dist.,
New Taipei City 24891, Taiwan. (R.O.C.)
<http://www.ccsrf.com>
service@ccsrf.com
Issued Date: November 11, 2015



Note: This report shall not be reproduced except in full, without the written approval of Compliance Certification Services Inc. This document may be altered or revised by Compliance Certification Services Inc. personnel only, and shall be noted in the revision section of the document.

Revision History

Rev.	Issue Date	Revisions	Effect Page	Revised By
00	November 11, 2015	Initial Issue	ALL	Kelly Cheng
01	November 30, 2015	Update KDB 789033 D02 v01	6	Kelly Cheng

TABLE OF CONTENTS

1. TEST RESULT CERTIFICATION.....	4
2. EUT DESCRIPTION.....	5
3. TEST METHODOLOGY.....	6
3.1 EUT CONFIGURATION	6
3.2 EUT EXERCISE	6
3.3 GENERAL TEST PROCEDURES.....	6
3.4 FCC PART 15.205 RESTRICTED BANDS OF OPERATIONS.....	7
3.5 DESCRIPTION OF TEST MODES.....	8
4. INSTRUMENT CALIBRATION.....	9
4.1 MEASURING INSTRUMENT CALIBRATION	9
4.2 MEASUREMENT EQUIPMENT USED	9
4.3 MEASUREMENT UNCERTAINTY	10
5. FACILITIES AND ACCREDITATIONS.....	11
5.1 FACILITIES	11
5.2 EQUIPMENT.....	11
5.3 TABLE OF ACCREDITATIONS AND LISTINGS.....	12
6. SETUP OF EQUIPMENT UNDER TEST.....	13
6.1 SETUP CONFIGURATION OF EUT	13
6.2 SUPPORT EQUIPMENT.....	13
7. FCC PART 15 REQUIREMENTS.....	14
7.1 26 DB EMISSION BANDWIDTH	14
7.2 MAXIMUM CONDUCTED OUTPUT POWER	35
7.3 BAND EDGES MEASUREMENT	38
7.4 PEAK POWER SPECTRAL DENSITY.....	47
7.5 RADIATED UNDESIRABLE EMISSION.....	68
7.6 POWERLINE CONDUCTED EMISSIONS.....	90
7.7 FREQUENCY STABILITY	93
APPENDIX I PHOTOGRAPHS OF TEST SETUP.....	109
APPENDIX 1 - PHOTOGRAPHS OF EUT	

1. TEST RESULT CERTIFICATION

Applicant: DrayTek Corp.
 No.26 Fu Shing Rd., HuKou County,Hsinchu Industrial
 Park,Hsinchu,Taiwan 303 R.O.C

Equipment Under Test: VigorAP 902 Dual Band 11ac AP

Trade Name: DrayTek

Model: VigorAP 902

Date of Test: March 11, 2015 ~ November 10, 2015

APPLICABLE STANDARDS	
STANDARD	TEST RESULT
FCC 47 CFR Part 15 Subpart E	No non-compliance noted

We hereby certify that:

Compliance Certification Services Inc. tested the above equipment. The test data, data evaluation, test procedures, and equipment configurations shown in this report were made in accordance with the procedures given in ANSI C63.10: 2009 and the energy emitted by the sample EUT tested as described in this report is in compliance with conducted and radiated emission limits of FCC Rules Part 15.407.

The test results of this report relate only to the tested sample identified in this report.

Approved by:

Reviewed by:



Miller Lee
 Manager
 Compliance Certification Services Inc.

Angel Cheng
 Section Manager
 Compliance Certification Services Inc.

2. EUT DESCRIPTION

Product	VigorAP 902 Dual Band 11ac AP				
Trade Name	DrayTek				
Model Number	VigorAP 902				
Model Discrepancy	N/A				
Received Date	October 01, 2015				
Power Adapter	Vdc from Power Adapter DVE / DSA-12PFT-12 FUS 120100 I/P: 100-240Vac, 50/60Hz, 0.5A O/P: +12Vdc, 1A				
Frequency Range	IEEE 802.11a, IEEE 802.11n HT20 : 5180MHz ~ 5240MHz; 5745 ~ 5825MHz IEEE 802.11n HT40 : 5190MHz ~ 5230MHz; 5755 ~ 5795MHz IEEE 802.11ac VHT80 mode: 5210MHz; 5775MHz				
Channel Number	IEEE 802.11a, IEEE 802.11n HT20 : 5180MHz ~ 5825MHz : 9 Channels IEEE 802.11n HT40 : 5190MHz ~ 5795MHz : 4 Channels IEEE 802.11ac VHT80 mode: 5210MHz ~ 5775MHz : 2 Channels				
Transmit Power		Mode	Frequency Range (MHz)	Transmit Power (dBm)	Transmit Power (W)
	UNII Band I	IEEE 802.11a	5180 – 5240	20.35	0.1084
		IEEE 802.11n HT 20 mode	5180 – 5240	22.86	0.1932
		IEEE 802.11n HT 40 mode	5190 ~ 5230	22.04	0.1600
		IEEE 802.11ac VHT80 mode	5210	18.82	0.0762
	UNII Band IV	IEEE 802.11a	5745 ~ 5825	20.42	0.1102
		IEEE 802.11n HT 20 mode	5745 ~ 5825	23.12	0.2051
		IEEE 802.11n HT 40 mode	5755 ~ 5815	22.66	0.1845
		IEEE 802.11ac VHT80 mode	5775	23.45	0.2213
Modulation Technique	OFDM (QPSK, BPSK, 16-QAM, 64-QAM, 256QAM)				
Transmit Data Rate	IEEE 802.11a mode: 54, 48, 36, 24, 18, 12, 9, 6 Mbps IEEE 802.11n HT 20 mode: OFDM (6.5, 7.2, 13, 14.4, 14.44, 19.5, 21.7, 26, 28.89, 28.9, 39, 43.3, 43.33 52, 57.78, 57.8, 58.5, 65.0, 72.2, 78, 86.67, 104, 115.56, 117, 130, 144.44 Mbps) IEEE 802.11n HT 40 mode: OFDM (13.5, 15, 27, 30, 40.5, 45, 54, 60, 81, 90, 108, 120, 121.5, 135, 150, 162, 180, 216, 240, 243, 270, 300 Mbps) IEEE 802.11ac VHT80 mode: OFDM (29.3, 58.5, 87.8, 117, 175.5, 234, 263.3, 292.5, 351, 390, 468, 526.5, 585, 702, 780 Mbps)				
Antenna Specification	MAG.LAYERS / EDA-1313-25GR2-A10-E Dipole Antenna / Gain: 3.88 dBi				

Remark:

1. The sample selected for test was engineering sample that approximated to production product and was provided by manufacturer.
2. This submittal(s) (test report) is intended for FCC ID: **VGYAP902** filing to comply with Section 15.407 of the FCC Part 15, Subpart E Rules.

3. TEST METHODOLOGY

Both conducted and radiated testing was performed according to the procedures in ANSI C63.10 Radiated testing was performed at an antenna to EUT distance 3 meters, KDB 789033 D02 v01.

3.1 EUT CONFIGURATION

The EUT configuration for testing is installed for RF field strength measurement to meet the Commissions requirement, and is operated in a manner intended to generate the maximum emission in a continuous normal application.

3.2 EUT EXERCISE

The EUT is operated in the engineering mode to fix the Tx frequency for the purposes of measurement.

According to its specifications, the EUT must comply with the requirements of Section 15.407 under the FCC Rules Part 15 Subpart E.

3.3 GENERAL TEST PROCEDURES

Conducted Emissions

The EUT is placed on the turntable, which is positioned at 0.8 m above the ground plane. According to the requirements in Section 13.1.4.1 of ANSI C63.10, the conducted emission from the EUT is measured in the frequency range between 0.15 MHz and 30MHz, using the CISPR Quasi-Peak detector mode.

Radiated Emissions

The EUT is placed on the turntable, which is 1.5 m above the ground plane. The turntable is then rotated for 360 degrees to determine the proper orientation for the maximum emission level. The EUT is set 3m away from the receiving antenna, which is varied from 1m to 4m to find out the highest emission level. And, each emission is to be maximized by changing the horizontal and vertical polarization of the receiving antenna. In order to find out the maximum emissions, exploratory radiated emission measurements were made according to the requirements in Section 13.1.4.1 of ANSI C63.10.

3.4 FCC PART 15.205 RESTRICTED BANDS OF OPERATIONS

(a) Except as shown in paragraph (d) of this section, only spurious emissions are permitted in any of the frequency bands listed below:

MHz	MHz	MHz	GHz
0.090 - 0.110	16.42 - 16.423	399.9 - 410	4.5 - 5.15
¹ 0.495 - 0.505	16.69475 - 16.69525	608 - 614	5.35 - 5.46
2.1735 - 2.1905	16.80425 - 16.80475	960 - 1240	7.25 - 7.75
4.125 - 4.128	25.5 - 25.67	1300 - 1427	8.025 - 8.5
4.17725 - 4.17775	37.5 - 38.25	1435 - 1626.5	9.0 - 9.2
4.20725 - 4.20775	73 - 74.6	1645.5 - 1646.5	9.3 - 9.5
6.215 - 6.218	74.8 - 75.2	1660 - 1710	10.6 - 12.7
6.26775 - 6.26825	108 - 121.94	1718.8 - 1722.2	13.25 - 13.4
6.31175 - 6.31225	123 - 138	2200 - 2300	14.47 - 14.5
8.291 - 8.294	149.9 - 150.05	2310 - 2390	15.35 - 16.2
8.362 - 8.366	156.52475 -	2483.5 - 2500	17.7 - 21.4
8.37625 - 8.38675	156.52525	2655 - 2900	22.01 - 23.12
8.41425 - 8.41475	156.7 - 156.9	3260 - 3267	23.6 - 24.0
12.29 - 12.293	162.0125 - 167.17	3332 - 3339	31.2 - 31.8
12.51975 - 12.52025	167.72 - 173.2	3345.8 - 3358	36.43 - 36.5
12.57675 - 12.57725	240 - 285	3600 - 4400	(²)
13.36 - 13.41	322 - 335.4		

¹ Until February 1, 1999, this restricted band shall be 0.490-0.510 MHz.

² Above 38.6

(b) Except as provided in paragraphs (d) and (e), the field strength of emissions appearing within these frequency bands shall not exceed the limits shown in Section 15.209. At frequencies equal to or less than 1000 MHz, compliance with the limits in Section 15.209 shall be demonstrated using measurement instrumentation employing a CISPR quasi-peak detector. Above 1000 MHz, compliance with the emission limits in Section 15.209 shall be demonstrated based on the average value of the measured emissions. The provisions in Section 15.35 apply to these measurements.

3.5 DESCRIPTION OF TEST MODES

The EUT (model: VigorAP 902) had been tested under operating condition.

The EUT is a 2x2 configuration spatial MIMO (2Tx & 2Rx) without beam forming function that operate in double TX chains and double RX chains. The 2x2 configuration is implemented with two outside TX & RX chains (Chain 0 and 1).

Software used to control the EUT for staying in continuous transmitting mode was programmed.

The field strength of spurious emission was measured in the following position: EUT stand-up position (Z axis), lie-down position (X, Y axis). The worst emission was found in lie-down position (X axis) and the worst case was recorded.

After verification, all tests were carried out with the worst case test modes as shown below except radiated spurious emission below 1GHz, which worst case was in normal link mode only.

Band I

IEEE 802.11a mode / 5180 ~ 5240MHz:

Channel Low (5180MHz), Channel Mid (5220MHz) and Channel High (5240MHz) with 6Mbps data rate were chosen for full testing.

IEEE 802.11n HT 20 mode / 5180 ~ 5240MHz:

Channel Low (5180MHz), Channel Mid (5220MHz) and Channel High (5240MHz) with 6.5Mbps data rate were chosen for full testing.

IEEE 802.11n HT 40 mode / 5190 ~ 5230MHz:

Channel Low (5190MHz) and Channel High (5230MHz) with 13.5Mbps data rate were chosen for full testing.

IEEE 802.11ac VHT80 Mode for 5210MHz:

Channel (5210MHz) with 6.5Mbps data rate were chosen for full testing.

Band IV

IEEE 802.11a mode / 5745 ~ 5825MHz

Channel Low (5745MHz), Channel Mid (5785MHz) and Channel High (5825MHz) with 6Mbps data rate were chosen for full testing.

IEEE 802.11n HT 20 mode: / 5745 ~ 5825MHz

Channel Low(5745MHz), Channel Mid(5785MHz) and Channel High(5825MHz) with 6.5Mbps data rate were chosen for full testing.

IEEE 802.11n HT 40 mode / 5755 ~ 5795MHz

Channel Low(5755MHz) and Channel High(5795MHz) with 13.5Mbps data rate were chosen for full testing.

IEEE 802.11ac VHT80 Mode for 5775MHz:

Channel (5775MHz) with 6.5Mbps data rate were chosen for full testing.

4. INSTRUMENT CALIBRATION

4.1 MEASURING INSTRUMENT CALIBRATION

The measuring equipment, which was utilized in performing the tests documented herein, has been calibrated in accordance with the manufacturer's recommendations for utilizing calibration equipment, which is traceable to recognized national standards.

4.2 MEASUREMENT EQUIPMENT USED

Equipment Used for Emissions Measurement

Remark: Each piece of equipment is scheduled for calibration once a year and Loop Antenna is scheduled for calibration once three years.

Conducted Emissions Test Site				
Name of Equipment	Manufacturer	Model	Serial Number	Calibration Due
Spectrum Analyzer	Agilent	E4446A	US42510252	11/23/2015
Thermostatic/Hrgrosatic Chamber	TAICHY	MHG-150LF	930619	10/06/2016
AC Power Source	EXTECH	6205	1140845	N.C.R
DC Power Supply	ABM	8301HD	D011531	N.C.R
Power Meter	Anritsu	ML2495A	1012009	06/07/2016
Power Sensor	Anritsu	MA2411A	0917072	06/08/2016
Spectrum Analyzer	ROHDE&SCHWARZ	FSV40	101073	07/08/2016

Wugu 966 Chamber A				
Name of Equipment	Manufacturer	Model	Serial Number	Calibration Due
Spectrum Analyzer	Agilent	E4446A	US42510268	01/25/2016
EMI Test Receiver	R&S	ESCI	100064	06/03/2016
Bilog Antenna	Sunol Sciences	JB3	A030105	08/05/2016
Horn Antenna	EMCO	3117	00055165	01/26/2016
Horn Antenna	EMCO	3116	26370	12/25/2015
Turn Table	CCS	CC-T-1F	N/A	N.C.R
Antenna Tower	CCS	CC-A-1F	N/A	N.C.R
Controller	CCS	CC-C-1F	N/A	N.C.R
Pre-Amplifier	MITEQ	1652-3000	1490939	08/09/2016
Pre-Amplifier	EMC	EMC 012635	980151	06/04/2016
Pre-Amplifier	MITEQ	AMF-6F-260400-4 0-8P	985646	12/25/2015
Coaxial Cable	Huber+Suhner	102	29212/2	12/25/2015
Coaxial Cable	Huber+Suhner	102	29406/2	12/25/2015
Test S/W	EZ-EMC (CCS-3A1RE)			

Conducted Emission Room # B				
Name of Equipment	Manufacturer	Model	Serial Number	Calibration Due
EMI Test Receiver	R&S	ESCI	101073	09/08/2016
LISN	R&S	ENV216	101054	06/06/2016
LISN	SCHWARZBECK	NSLK 8127	8127-541	11/25/2015
Capacitive Voltage Probe	FCC	F-CVP-1	100185	03/12/2016
Test S/W	CCS-3A1-CE			

4.3 MEASUREMENT UNCERTAINTY

PARAMETER	UNCERTAINTY
Powerline Conducted Emission	+/- 1.2159
3M Semi Anechoic Chamber / <200M	+/- 4.0138
3M Semi Anechoic Chamber / 200M~1000M	+/- 3.9483
3M Semi Anechoic Chamber / 1G~8G	+/- 2.5975
3M Semi Anechoic Chamber / 8G~18G	+/- 2.6112
3M Semi Anechoic Chamber / 18G~26G	+/- 2.7389
3M Semi Anechoic Chamber / 26G~40G	+/- 2.9683

Remark: This uncertainty represents an expanded uncertainty expressed at approximately the 95% confidence level using a coverage factor of $k=2$.

5. FACILITIES AND ACCREDITATIONS

5.1 FACILITIES

All measurement facilities used to collect the measurement data are located at

- No.199, Chunghsen Road, Hsintien City, Taipei Hsien, Taiwan, R.O.C.
- No.139, Wugong Rd., Wugu Dist., New Taipei City 24891, Taiwan (R.O.C.)
- No.11, Wugong 6th Rd., Wugu Dist., New Taipei City 24891, Taiwan. (R.O.C.)
- No.81-1, Lane 210, Bade 2nd Rd., Lujhu Township, Taoyuan County 33841, TAIWAN, R.O.C.

The sites are constructed in conformance with the requirements of ANSI C63.7, ANSI C63.10 and CISPR Publication 22.

5.2 EQUIPMENT



Radiated emissions are measured with one or more of the following types of linearly polarized antennas: tuned dipole, biconical, log periodic, bi-log, and/or ridged waveguide, horn. Spectrum analyzers with pre-selectors and quasi-peak detectors are used to perform radiated measurements.

Conducted emissions are measured with Line Impedance Stabilization Networks and EMI Test Receivers.

Calibrated wideband preamplifiers, coaxial cables, and coaxial attenuators are also used for making measurements.

All receiving equipment conforms to CISPR Publication 16-1, "Radio Interference Measuring Apparatus and Measurement Methods."

5.3 TABLE OF ACCREDITATIONS AND LISTINGS

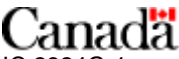
Country	Agency	Scope of Accreditation	Logo
USA	FCC	3M Semi Anechoic Chamber (FCC MRA: TW1039) to perform FCC Part 15 measurements	 FCC MRA: TW1039
Taiwan	TAF	LP0002, RTTE01, FCC Method-47 CFR Part 15 Subpart C, D, E, RSS-310 IDA TS SRD, AS/NZS 4268, AS/NZS 4771, TS 12.1 & 12.2, ETSI EN 300 440-1, ETSI EN 300 440-2, ETSI EN 300 328, ETSI EN 300 220-1, ETSI EN 300 220-2, ETSI EN 301 893, ETSI EN 301 489-1/3/7/17 FCC OET Bulletin 65 + Supplement C, EN 50360, EN 50361, EN 50371, RSS 102, EN 50383, EN 50385, EN 50392, IEC 62209, CNS 14958-1, CNS 14959 FCC Method -47 CFR Part 15 Subpart B IEC / EN 61000-3-2, IEC / EN 61000-3-3, IEC / EN 61000-4-2/3/4/5/6/8/11	
Canada	Industry Canada	3M Semi Anechoic Chamber (IC 2324G-1 / IC 2324G-2) to perform	 IC 2324G-1 IC 2324G-2

* No part of this report may be used to claim or imply product endorsement by A2LA or any agency of the US Government.

6. SETUP OF EQUIPMENT UNDER TEST

6.1 SETUP CONFIGURATION OF EUT

See test photographs attached in Appendix I for the actual connections between EUT and support equipment.

6.2 SUPPORT EQUIPMENT

No	Equipment	Brand	Model	Series No.	FCC ID	Data Cable	Power Cord
1	Printer	EPSON	Stylus-C63	FAPY150360	R33126	N/A	Non-shielded, 1.8m
2	Notebook PC (Remote)	HP	Pavilion dv6	CNF9491GLJ	R33022	N/A	Non-shielded, 2.0m
3	Notebook PC (Remote)	HP	Pavilion dv6	VX250PA#ABO	R33022	N/A	Non-shielded, 2.0m
4	Terminal (Remote)	N/A	N/A	N/A	N/A	N/A	N/A
5	WIFI Dongle	EDIMAX	AC600	N/A	N/A	N/A	N/A

Remark:

1. All the equipment/cables were placed in the worst-case configuration to maximize the emission during the test.
2. Grounding was established in accordance with the manufacturer's requirements and conditions for the intended use.

7. FCC PART 15 REQUIREMENTS

7.1 26 DB EMISSION BANDWIDTH

LIMIT

According to §15.303(c), for purposes of this subpart the emission bandwidth shall be determined by measuring the width of the signal between two points, one below the carrier center frequency and one above the carrier center frequency, that are 26 dB down relative to the maximum level of the modulated carrier. Compliance with the emissions limits is based on the use of measurement instrumentation employing a peak detector function with an instrument resolutions bandwidth approximately equal to 1.0 percent of the emission bandwidth of the device under measurement.

Test Configuration

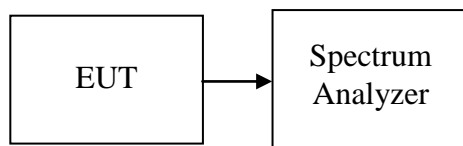

TEST PROCEDURE

1. Place the EUT on the table and set it in the transmitting mode.
2. Remove the antenna from the EUT and then connect a low-loss RF cable from the antenna port to the spectrum analyzer.
3. Set the spectrum analyzer as RBW > 1%EBW, VBW > RBW, Span >26dB bandwidth, and Sweep = auto.
4. Mark the peak frequency and -26dB (upper and lower) frequency.
5. Repeat until all the rest channels were investigated.

TEST RESULTS

No non-compliance noted

Test Data

Test mode: IEEE 802.11a mode / 5180 ~ 5240MHz

Channel	Frequency (MHz)	Bandwidth (MHz)
Low	5180	39.846
Mid	5220	40.000
High	5240	39.658

Test mode: IEEE 802.11n HT 20 mode / 5180 ~ 5240MHz

Channel	Frequency (MHz)	Chain 0 Bandwidth (MHz)	Chain 1 Bandwidth (MHz)
Low	5180	39.087	39.221
Mid	5220	40.000	39.698
High	5240	40.000	40.000

Test mode: IEEE 802.11n HT 40 mode / 5190 ~ 5230MHz

Channel	Frequency (MHz)	Chain 0 Bandwidth (MHz)	Chain 1 Bandwidth (MHz)
Low	5190	66.601	41.609
High	5230	79.907	61.102

Test mode: IEEE 802.11ac VHT80 Mode/ 5210MHz

Channel	Frequency (MHz)	Chain 0 Bandwidth (MHz)	Chain 1 Bandwidth (MHz)
Mid	5210	85.198	81.569

Test mode: IEEE 802.11a mode / 5745 ~ 5825MHz

Channel	Frequency (MHz)	Bandwidth (MHz)
Low	5745	16.286
Mid	5785	16.303
High	5825	16.303

Test mode: IEEE 802.11n HT 20 mode / 5745 ~ 5825MHz

Channel	Frequency (MHz)	Chain 0 Bandwidth (MHz)	Chain 1 Bandwidth (MHz)
Low	5745	17.613	17.744
Mid	5785	17.629	17.657
High	5825	17.667	17.761

Test mode: IEEE 802.11n HT 40 mode / 5755 ~ 5815MHz

Channel	Frequency (MHz)	Chain 0 Bandwidth (MHz)	Chain 1 Bandwidth (MHz)
Low	5755	36.223	35.888
High	5795	36.427	36.174

Test mode: IEEE 802.11ac VHT80 Mode/ 5775MHz

Channel	Frequency (MHz)	Chain 0 Bandwidth (MHz)	Chain 1 Bandwidth (MHz)
Mid	5775	74.191	73.386

Test Plot

IEEE 802.11a mode / 5180 ~ 5240MHz

CH Low

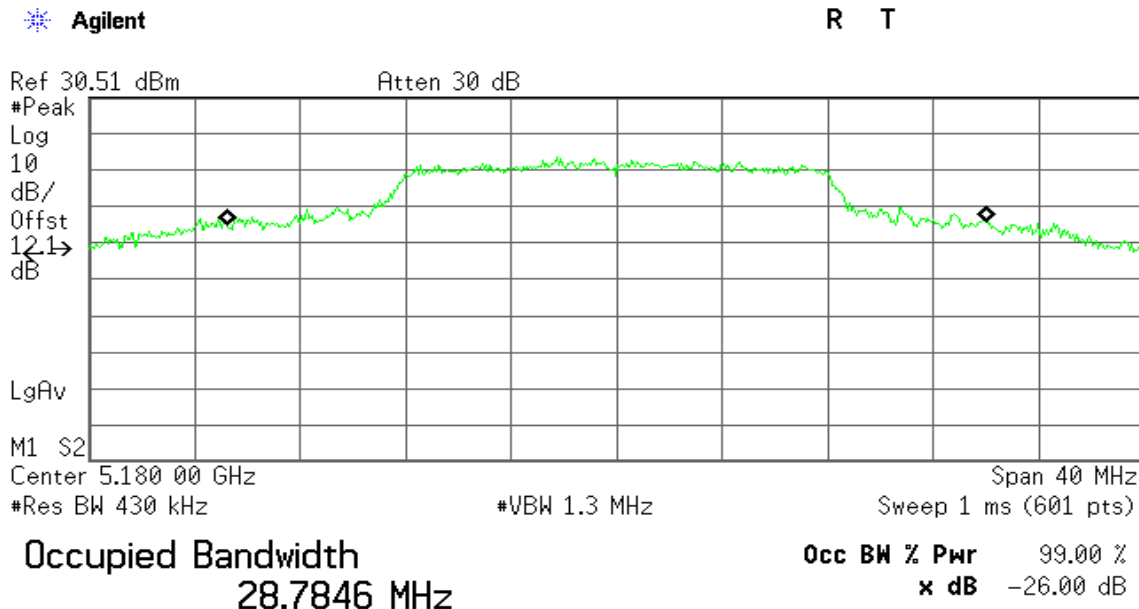

Transmit Freq Error -369.166 kHz
x dB Bandwidth 39.846 MHz

CH Mid

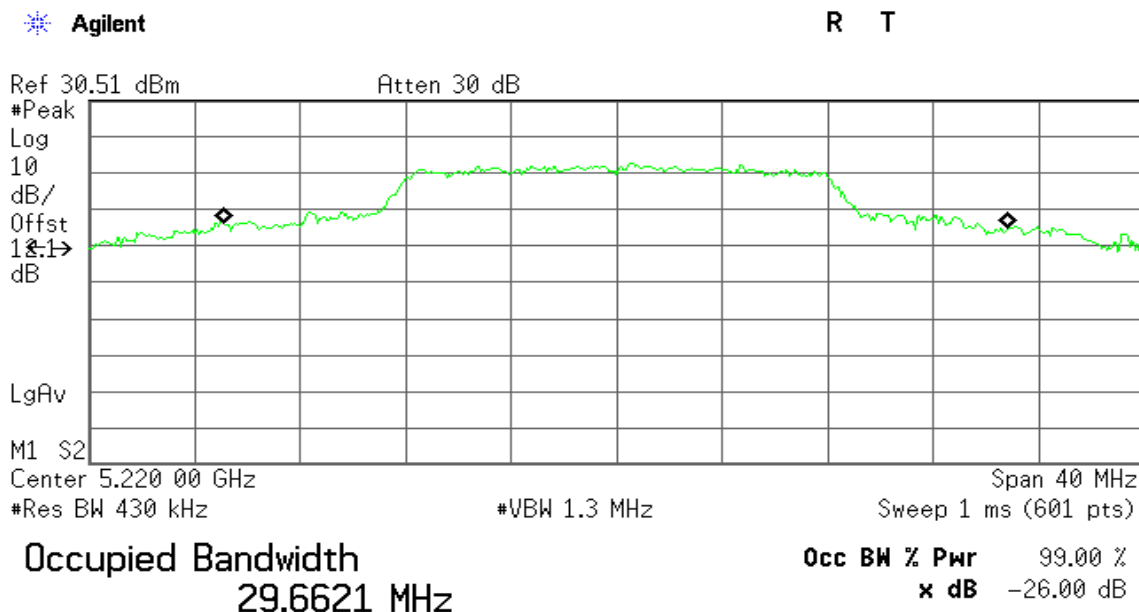

Transmit Freq Error -25.714 kHz
x dB Bandwidth 40.000 MHz

CH High

Agilent

R T

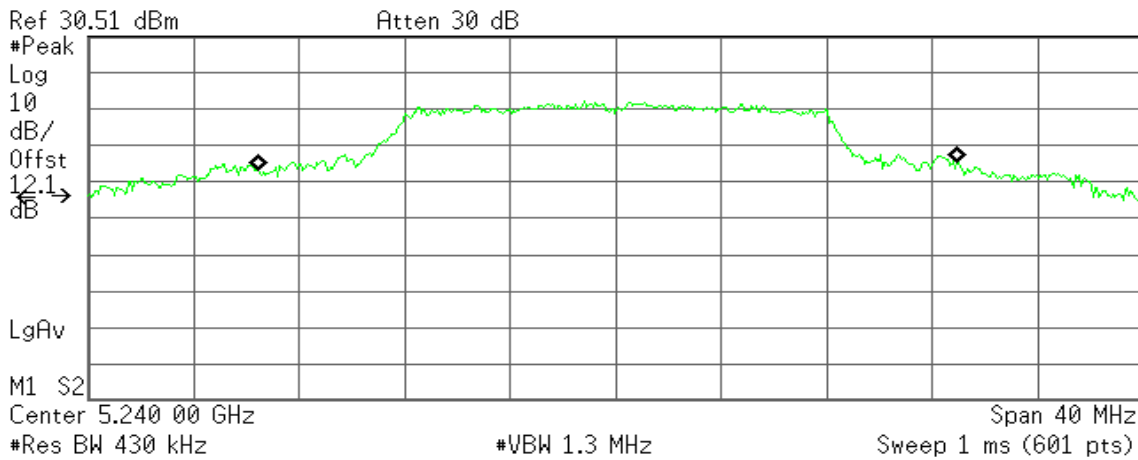

Occupied Bandwidth

26.5188 MHz

Occ BW % Pwr 99.00 %
x dB -26.00 dB

Transmit Freq Error -300.449 kHz
x dB Bandwidth 39.658 MHz

IEEE 802.11n HT 20 mode / 5180 ~ 5240MHz / Chain 0

CH Low

Agilent

R T

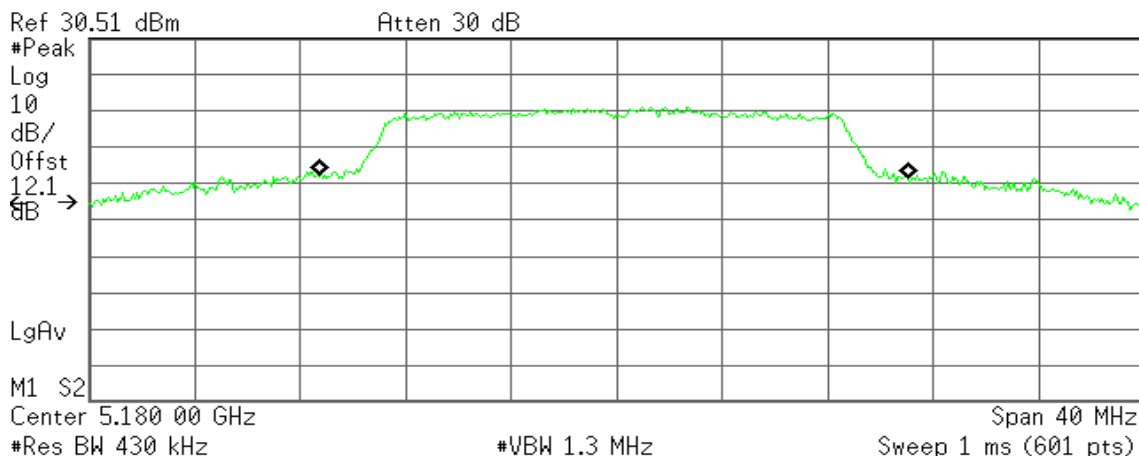

Occupied Bandwidth
 22.2872 MHz

Occ BW % Pwr 99.00 %
x dB -26.00 dB

Transmit Freq Error -103.488 kHz
x dB Bandwidth 39.087 MHz

CH Mid

Agilent

R T

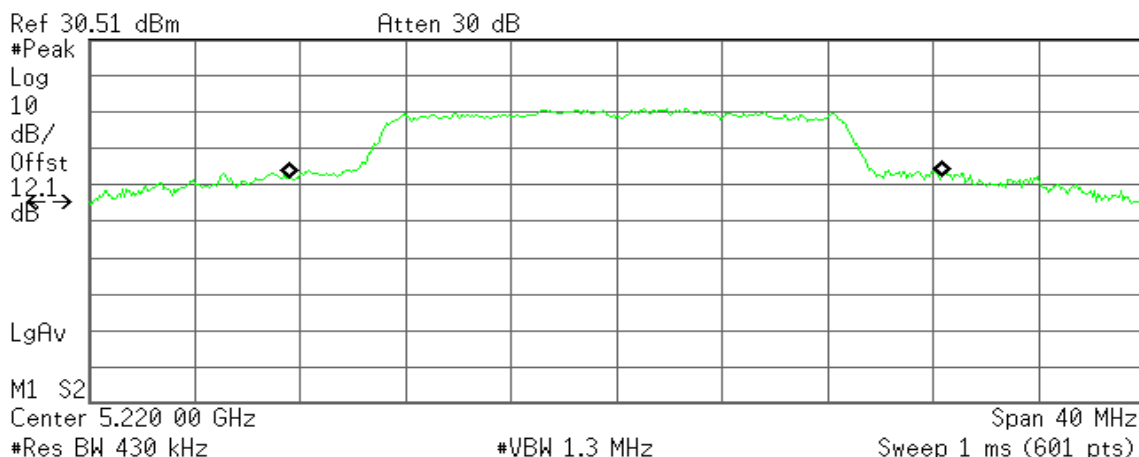

Occupied Bandwidth
 24.7173 MHz

Occ BW % Pwr 99.00 %
x dB -26.00 dB

Transmit Freq Error -48.129 kHz
x dB Bandwidth 40.000 MHz

CH High

Agilent

R T

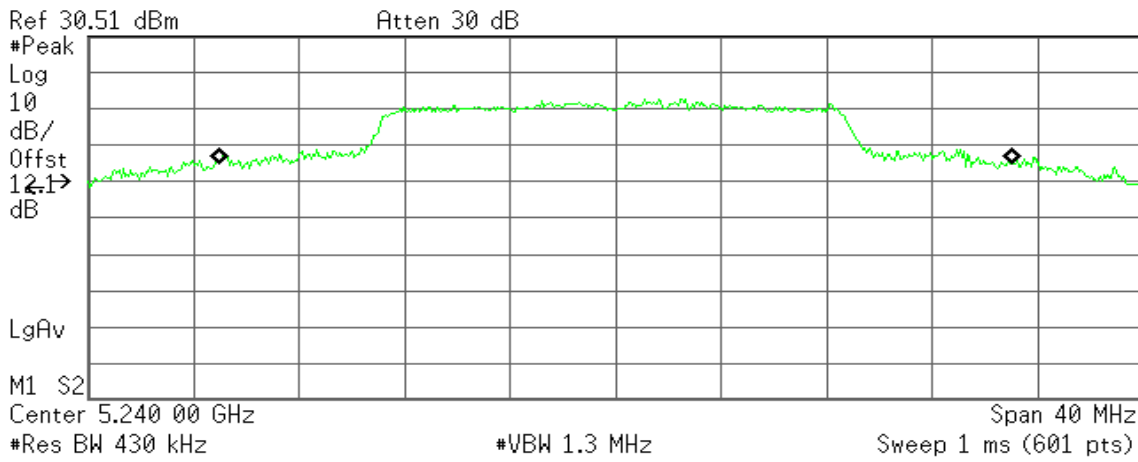

Occupied Bandwidth
 29.9766 MHz

Occ BW % Pwr 99.00 %
x dB -26.00 dB

Transmit Freq Error 5.505 kHz
x dB Bandwidth 40.000 MHz

IEEE 802.11n HT 20 mode / 5180 ~ 5240MHz / Chain 1

CH Low

Agilent

R T

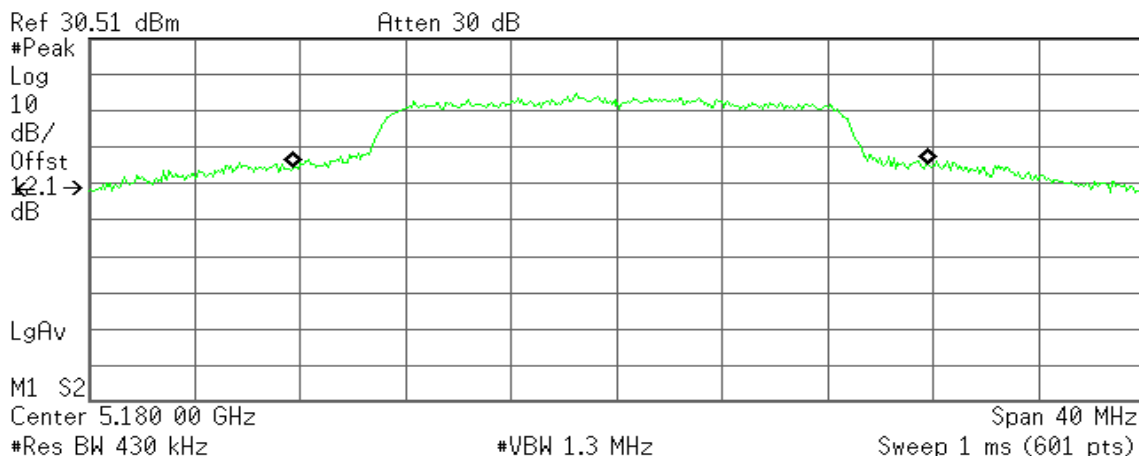

Occupied Bandwidth
 24.0751 MHz

Occ BW % Pwr 99.00 %
x dB -26.00 dB

Transmit Freq Error -238.907 kHz
x dB Bandwidth 39.221 MHz

CH Mid

Agilent

R T

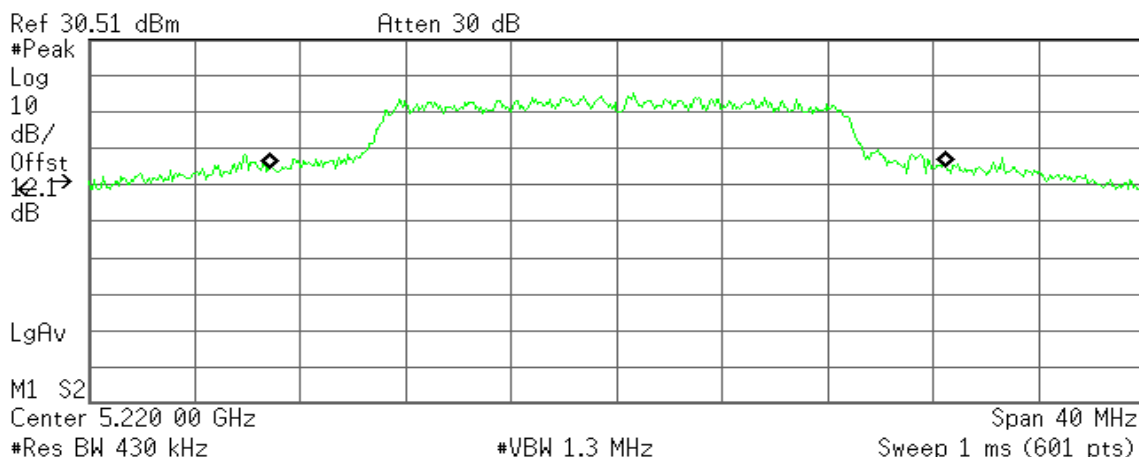

Occupied Bandwidth
 25.5938 MHz

Occ BW % Pwr 99.00 %
x dB -26.00 dB

Transmit Freq Error -312.446 kHz
x dB Bandwidth 39.698 MHz

CH High

Agilent

R T

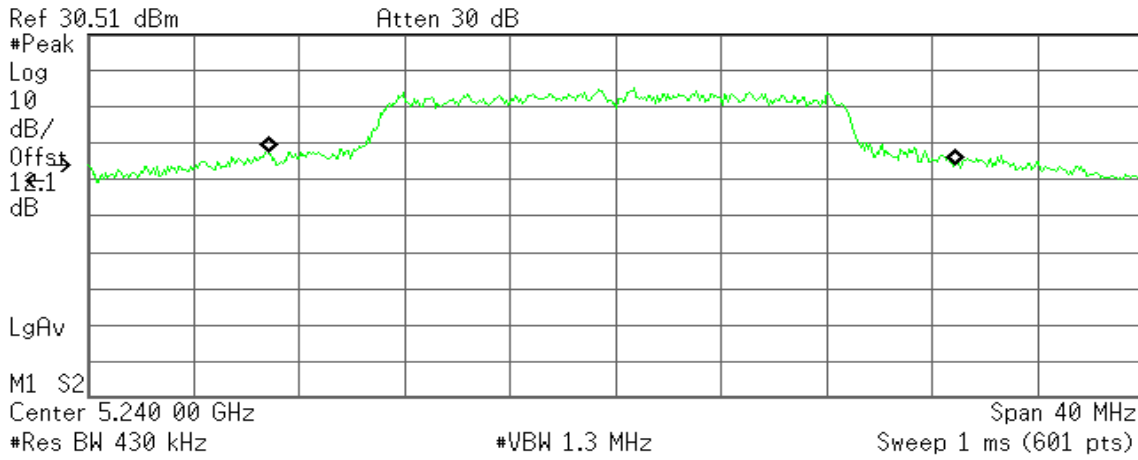

Occupied Bandwidth
 26.0141 MHz

Occ BW % Pwr 99.00 %
x dB -26.00 dB

Transmit Freq Error -148.677 kHz
x dB Bandwidth 40.000 MHz

IEEE 802.11n HT 40 mode / 5190 ~ 5230MHz / Chain 0

CH Low

Agilent

R T

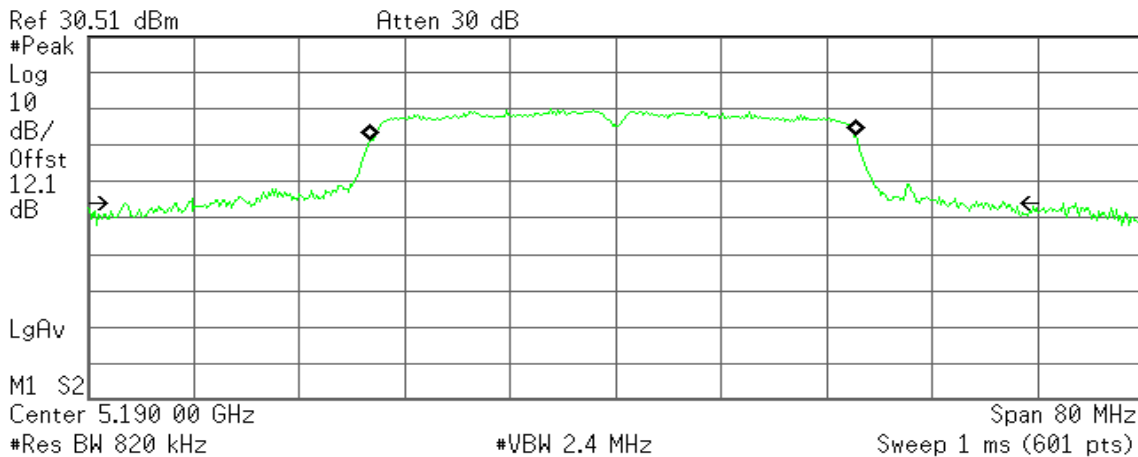

Occupied Bandwidth
36.9143 MHz

Occ BW % Pwr 99.00 %
x dB -26.00 dB

Transmit Freq Error -217.928 kHz
x dB Bandwidth 66.601 MHz

CH High

Agilent

R T

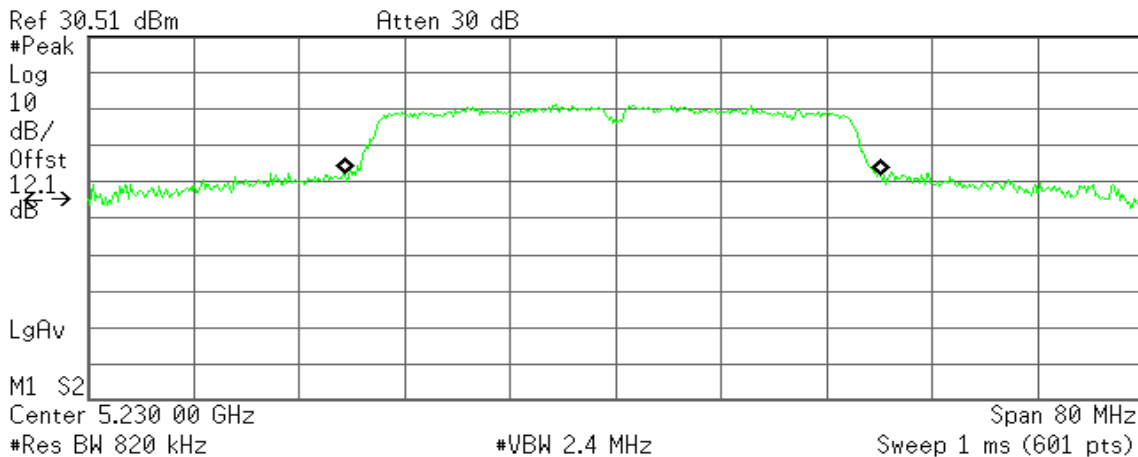

Occupied Bandwidth
40.7698 MHz

Occ BW % Pwr 99.00 %
x dB -26.00 dB

Transmit Freq Error -213.302 kHz
x dB Bandwidth 79.907 MHz

IEEE 802.11n HT 40 mode / 5190 ~ 5230MHz / Chain 1

CH Low

Agilent

R T

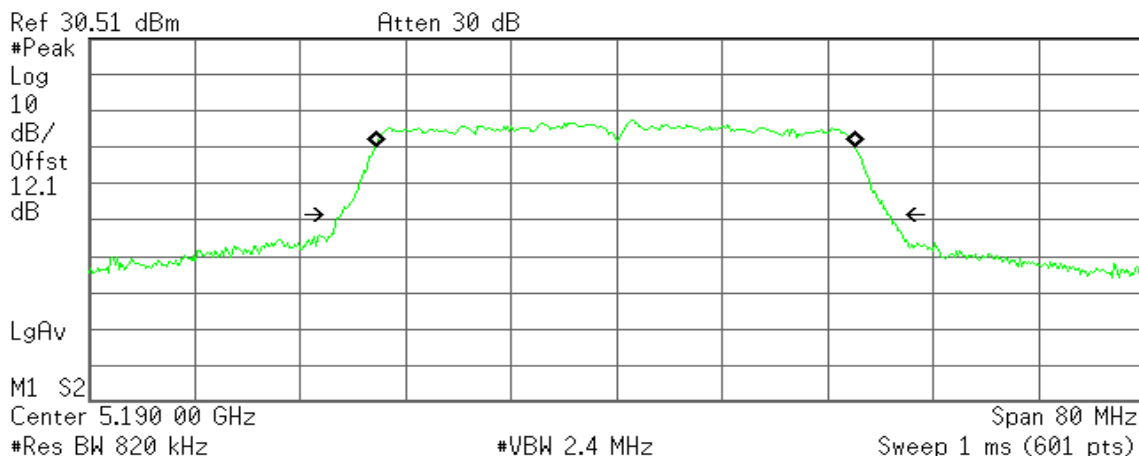

Occupied Bandwidth
36.4007 MHz

Occ BW % Pwr 99.00 %
x dB -26.00 dB

Transmit Freq Error -112.139 kHz
x dB Bandwidth 41.609 MHz

CH High

Agilent

R T

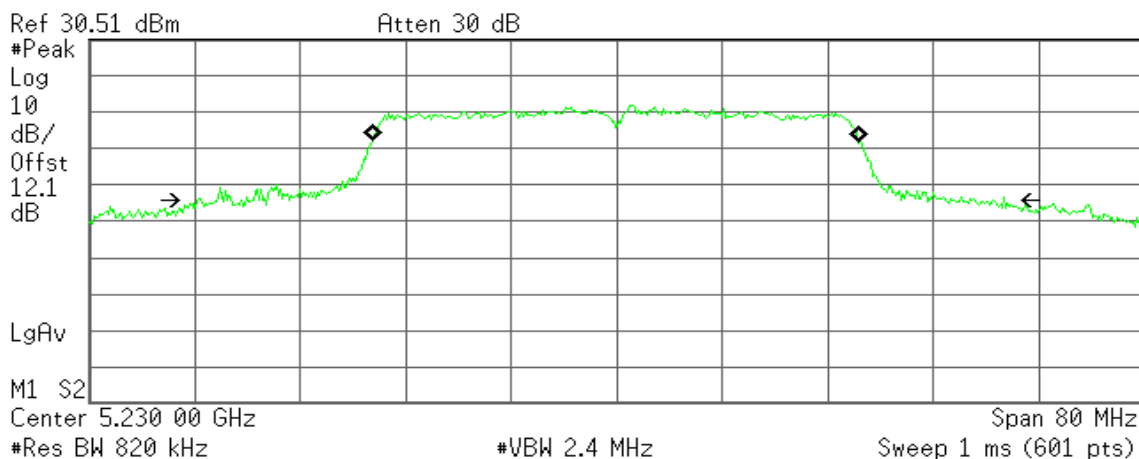

Occupied Bandwidth
36.9133 MHz

Occ BW % Pwr 99.00 %
x dB -26.00 dB

Transmit Freq Error -84.369 kHz
x dB Bandwidth 61.102 MHz

IEEE 802.11ac VHT80 Mode / 5210MHz / Chain 0

CH Mid

Agilent

R T

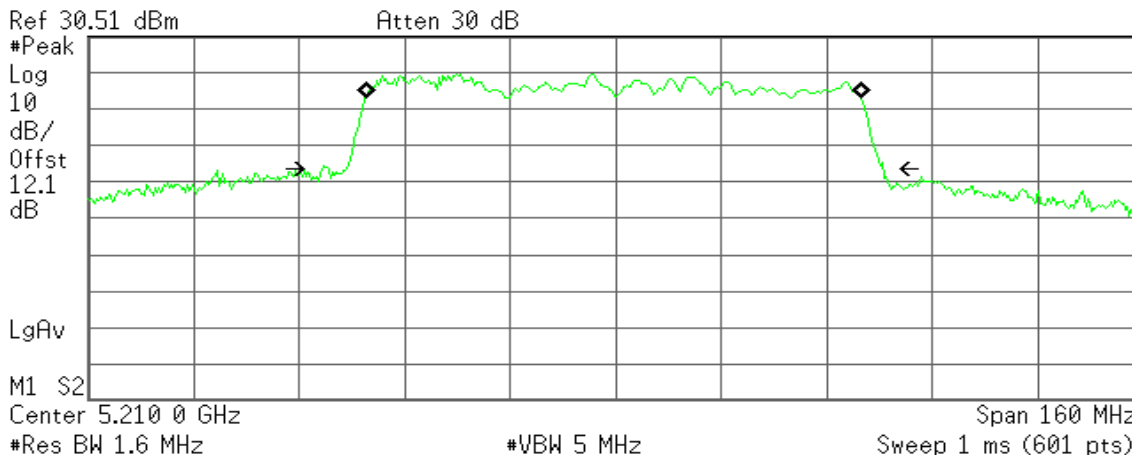

Occupied Bandwidth
 75.2052 MHz

Occ BW % Pwr 99.00 %
x dB -26.00 dB

Transmit Freq Error -370.844 kHz
x dB Bandwidth 85.198 MHz

IEEE 802.11ac VHT80 Mode / 5210MHz / Chain 1

CH Mid

Agilent

R T

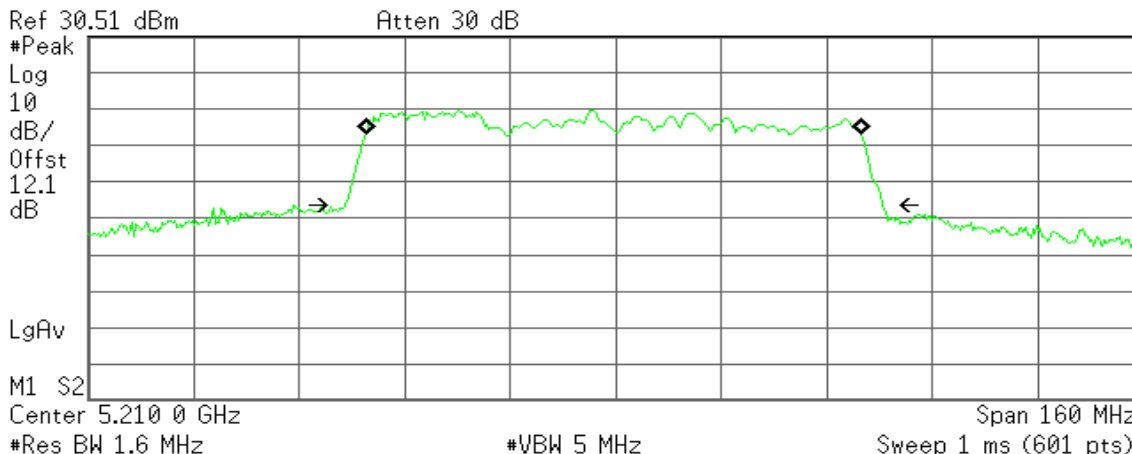

Occupied Bandwidth
 75.1865 MHz

Occ BW % Pwr 99.00 %
x dB -26.00 dB

Transmit Freq Error -377.058 kHz
x dB Bandwidth 81.569 MHz

IEEE 802.11a mode / 5745 ~ 5825MHz

CH Low

Agilent

R T

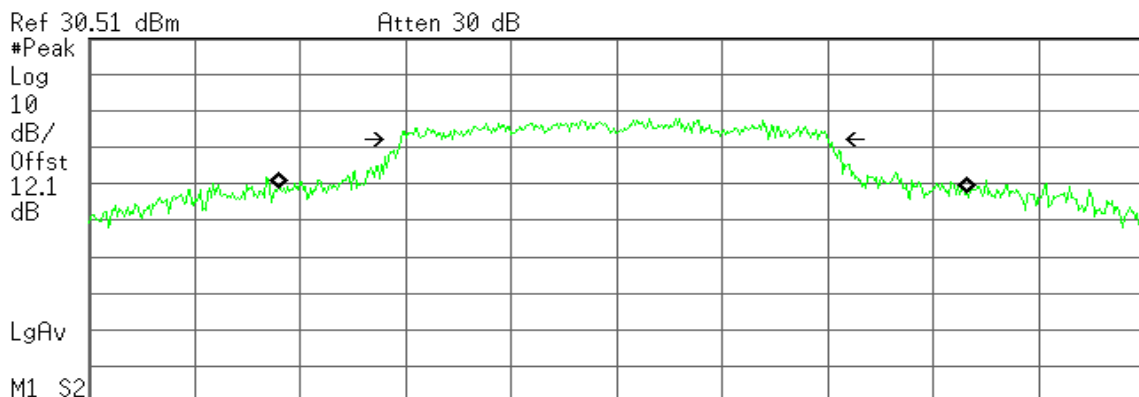

Ref 30.51 dBm Atten 30 dB
 #Peak
 Log
 10
 dB/
 Offst
 12.1
 dB
 LgAv
 M1 S2
 Center 5.745 00 GHz Span 40 MHz
 #Res BW 430 kHz #VBW 1.3 MHz Sweep 1 ms (601 pts)

Occupied Bandwidth
 26.0828 MHz

Occ BW % Pwr 99.00 %
x dB -6.00 dB

Transmit Freq Error 232.861 kHz
x dB Bandwidth 16.286 MHz

CH Mid

Agilent

R T

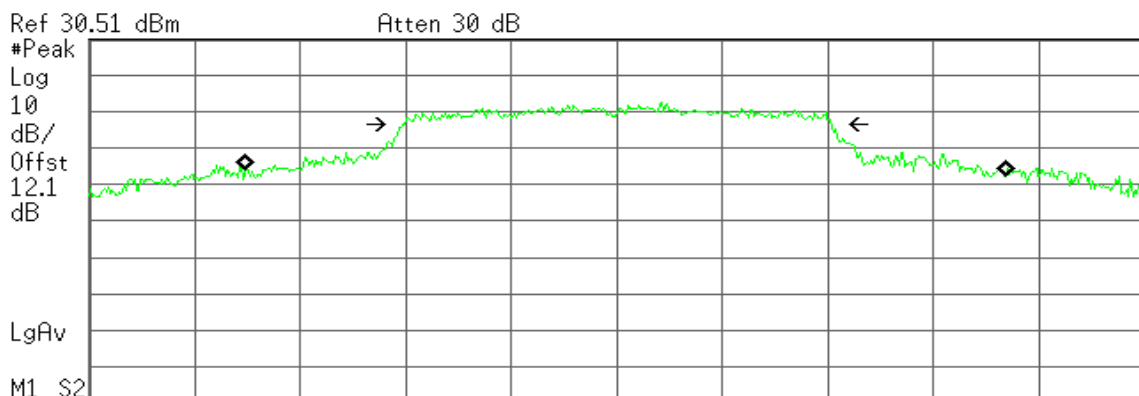

Ref 30.51 dBm Atten 30 dB
 #Peak
 Log
 10
 dB/
 Offst
 12.1
 dB
 LgAv
 M1 S2
 Center 5.785 00 GHz Span 40 MHz
 #Res BW 430 kHz #VBW 1.3 MHz Sweep 1 ms (601 pts)

Occupied Bandwidth
 28.7452 MHz

Occ BW % Pwr 99.00 %
x dB -6.00 dB

Transmit Freq Error 338.183 kHz
x dB Bandwidth 16.303 MHz

CH High

Agilent

R T

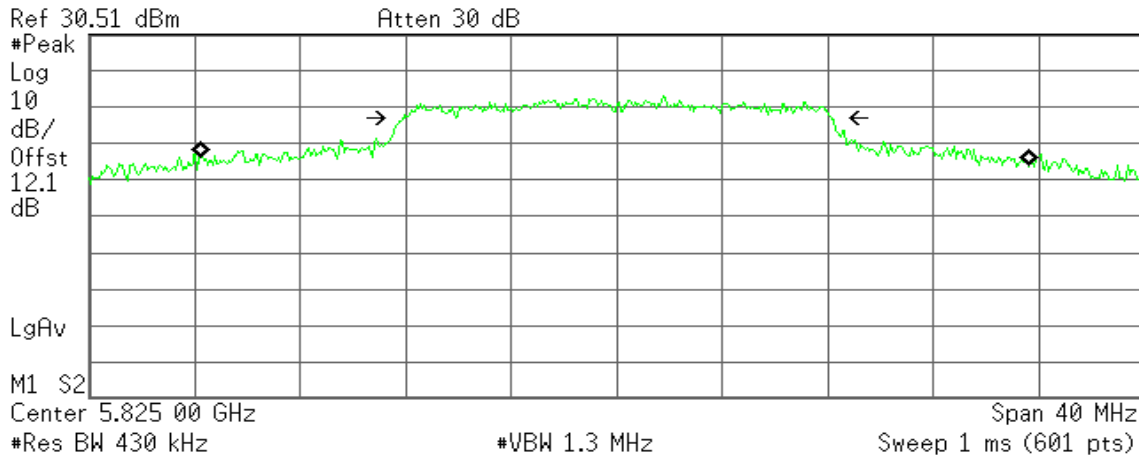

Occupied Bandwidth
 31.3359 MHz

Occ BW % Pwr 99.00 %
x dB -6.00 dB

Transmit Freq Error -94.478 kHz
x dB Bandwidth 16.303 MHz

IEEE 802.11n HT 20 mode / 5745 ~ 5825MHz / Chain 0

CH Low

Agilent

R T

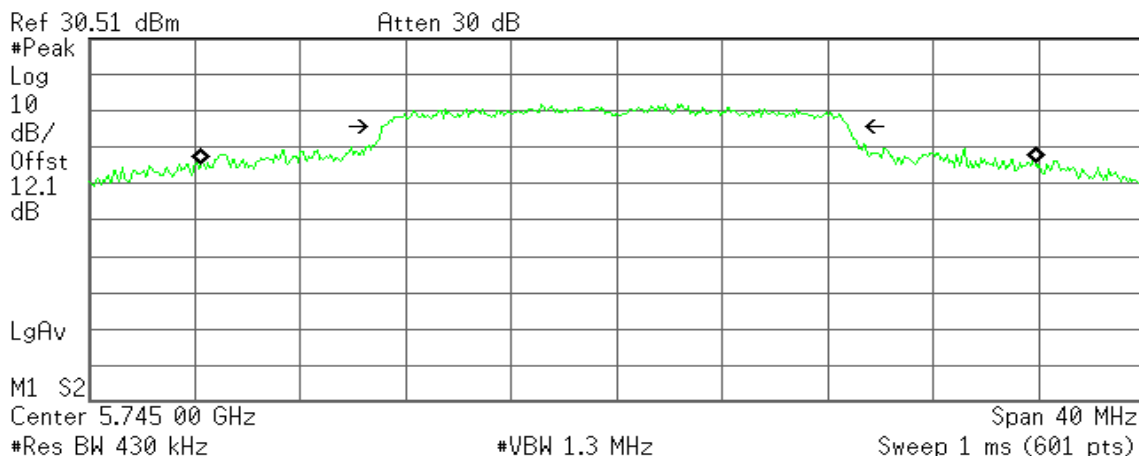

Occupied Bandwidth
 31.5631 MHz

Occ BW % Pwr 99.00 %
x dB -6.00 dB

Transmit Freq Error 64.323 kHz
x dB Bandwidth 17.613 MHz

CH Mid

Agilent

R T

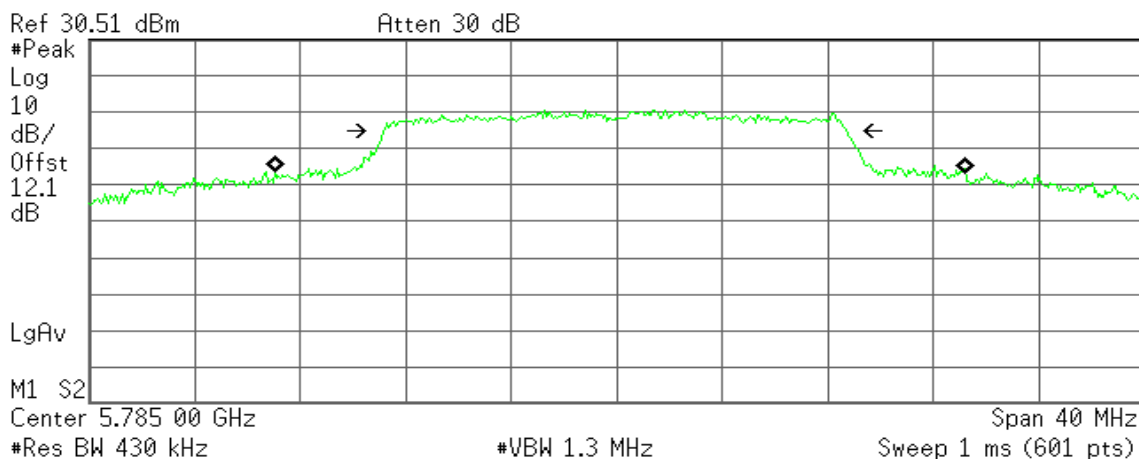

Occupied Bandwidth
 26.1425 MHz

Occ BW % Pwr 99.00 %
x dB -6.00 dB

Transmit Freq Error 152.517 kHz
x dB Bandwidth 17.629 MHz

CH High

Agilent

R T

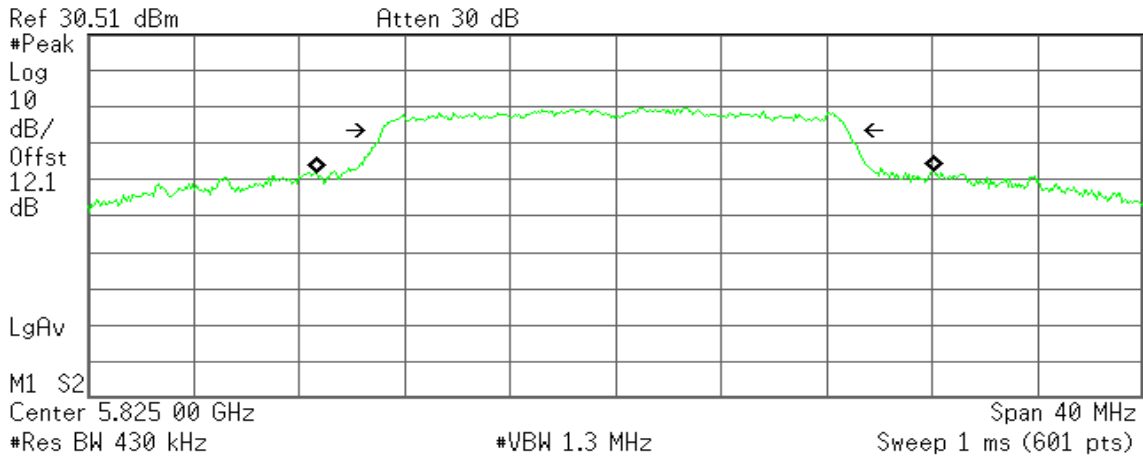

Occupied Bandwidth
 23.4187 MHz

Occ BW % Pwr 99.00 %
x dB -6.00 dB

Transmit Freq Error 355.852 kHz
x dB Bandwidth 17.667 MHz

IEEE 802.11n HT 20 mode / 5745 ~ 5825MHz / Chain 1

CH Low

Agilent

R T

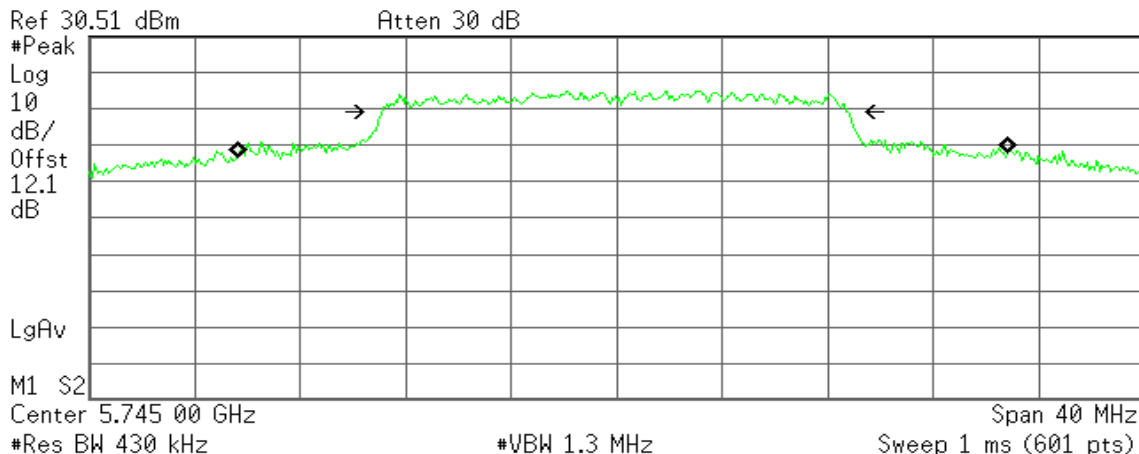

Occupied Bandwidth
 29.1541 MHz

Occ BW % Pwr 99.00 %
x dB -6.00 dB

Transmit Freq Error 238.393 kHz
x dB Bandwidth 17.744 MHz

CH Mid

Agilent

R T

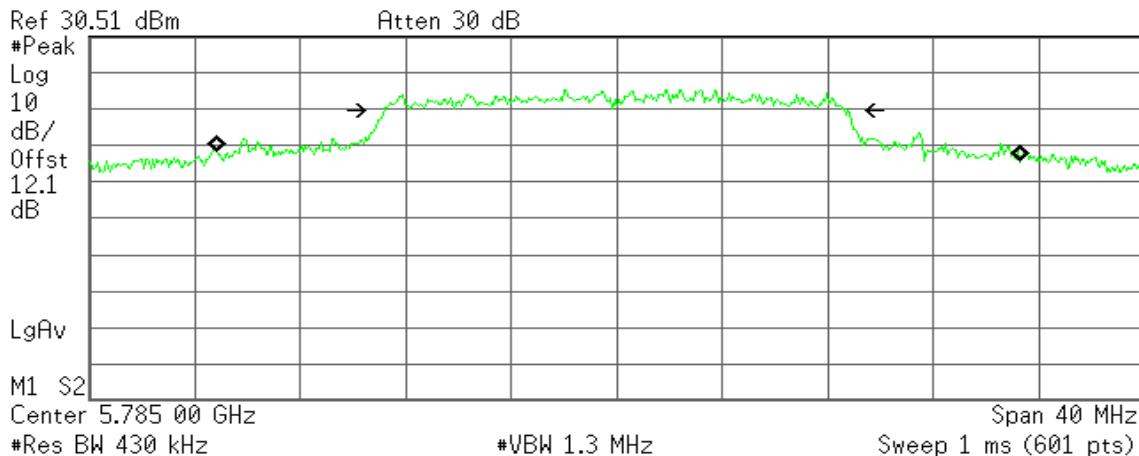

Occupied Bandwidth
 30.4120 MHz

Occ BW % Pwr 99.00 %
x dB -6.00 dB

Transmit Freq Error 78.888 kHz
x dB Bandwidth 17.657 MHz

CH High

Agilent

R T

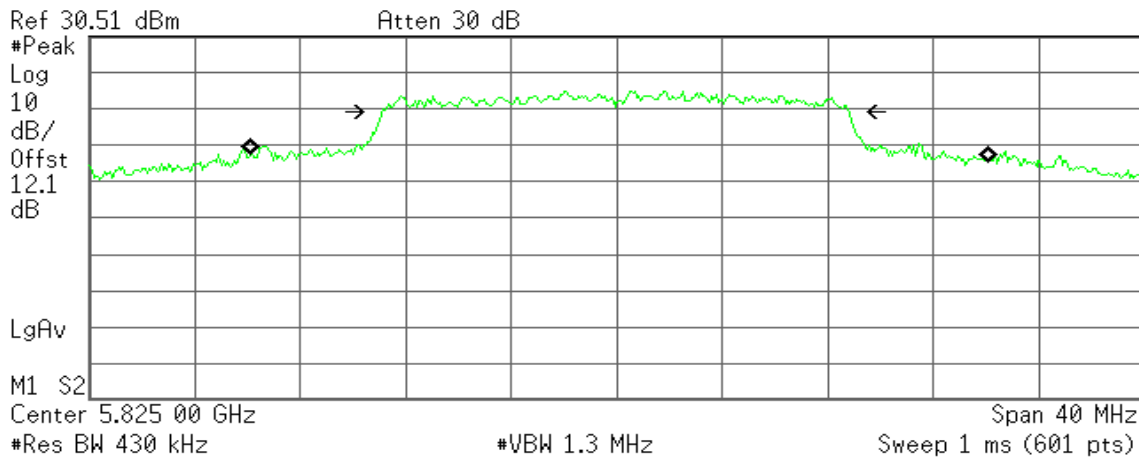

Occupied Bandwidth
 27.9189 MHz

Occ BW % Pwr 99.00 %
x dB -6.00 dB

Transmit Freq Error 119.936 kHz
x dB Bandwidth 17.761 MHz

IEEE 802.11n HT 40 mode / 5755 ~ 5795MHz / Chain 0

CH Low

Agilent

R T

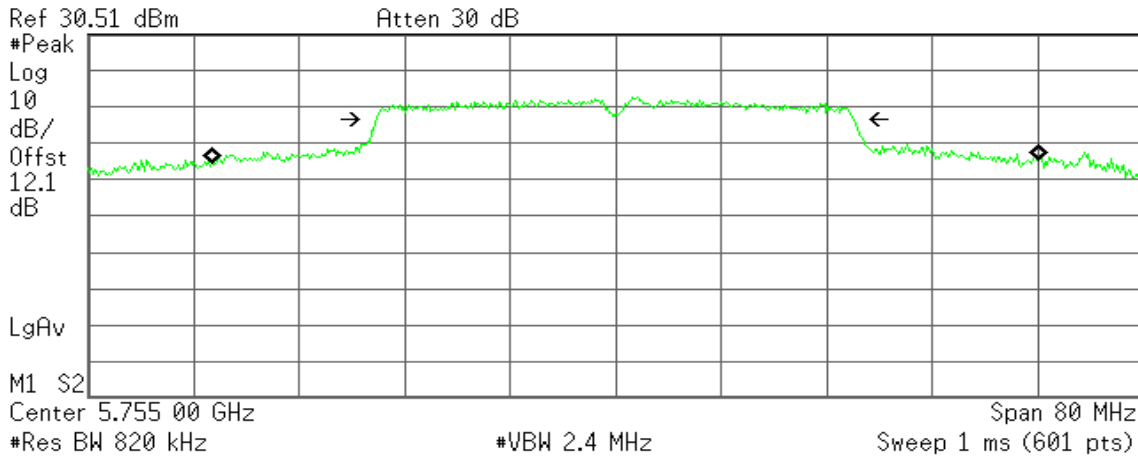

Occupied Bandwidth
 62.7116 MHz

Occ BW % Pwr 99.00 %
x dB -6.00 dB

Transmit Freq Error 796.369 kHz
x dB Bandwidth 36.223 MHz

CH High

Agilent

R T

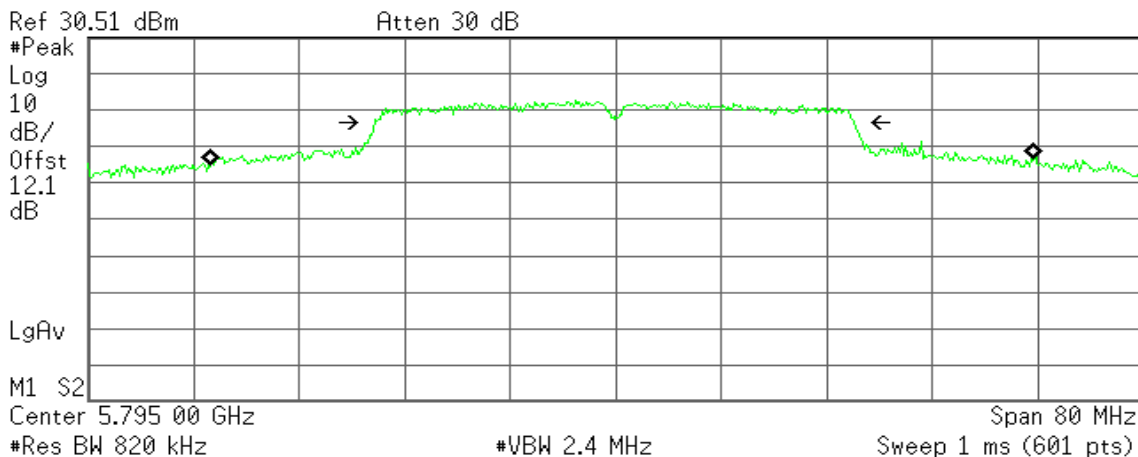

Occupied Bandwidth
 62.2735 MHz

Occ BW % Pwr 99.00 %
x dB -6.00 dB

Transmit Freq Error 520.630 kHz
x dB Bandwidth 36.427 MHz

IEEE 802.11n HT 40 mode / 5755 ~ 5795MHz / Chain 1

CH Low

Agilent

R T

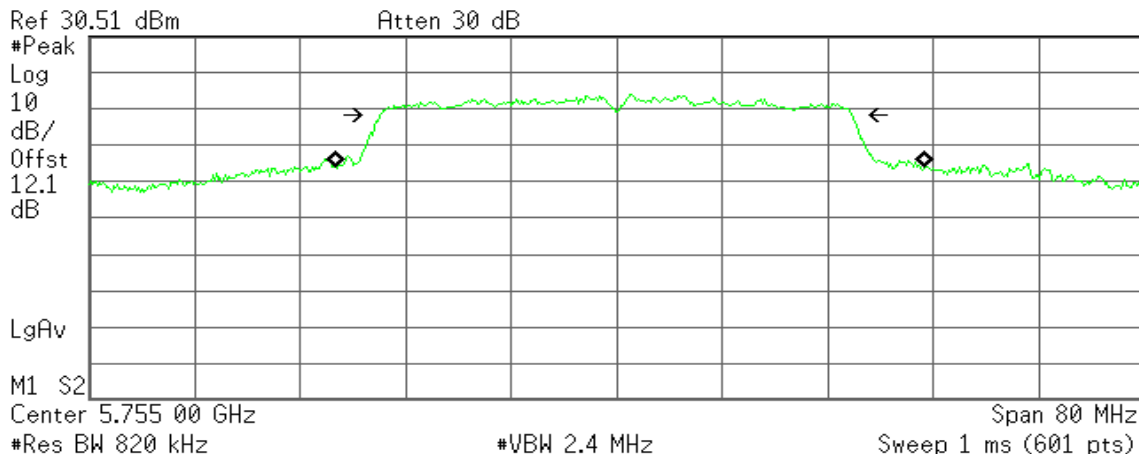

Occupied Bandwidth
 44.6156 MHz

Occ BW % Pwr 99.00 %
x dB -6.00 dB

Transmit Freq Error 1.039 MHz
x dB Bandwidth 35.888 MHz

CH High

Agilent

R T

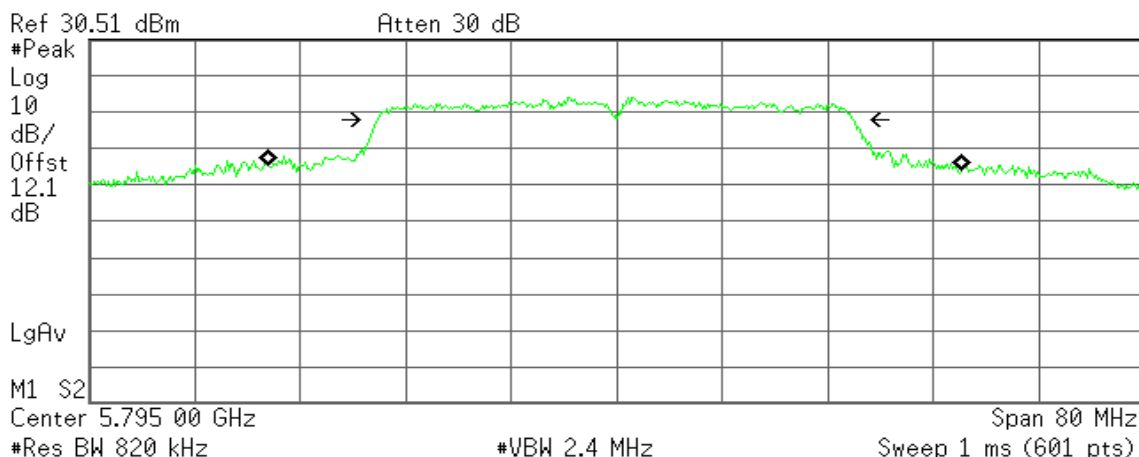

Occupied Bandwidth
 52.5506 MHz

Occ BW % Pwr 99.00 %
x dB -6.00 dB

Transmit Freq Error -153.109 kHz
x dB Bandwidth 36.174 MHz

IEEE 802.11ac VHT80 Mode / 5775MHz / Chain 0

CH Mid

Agilent

R T

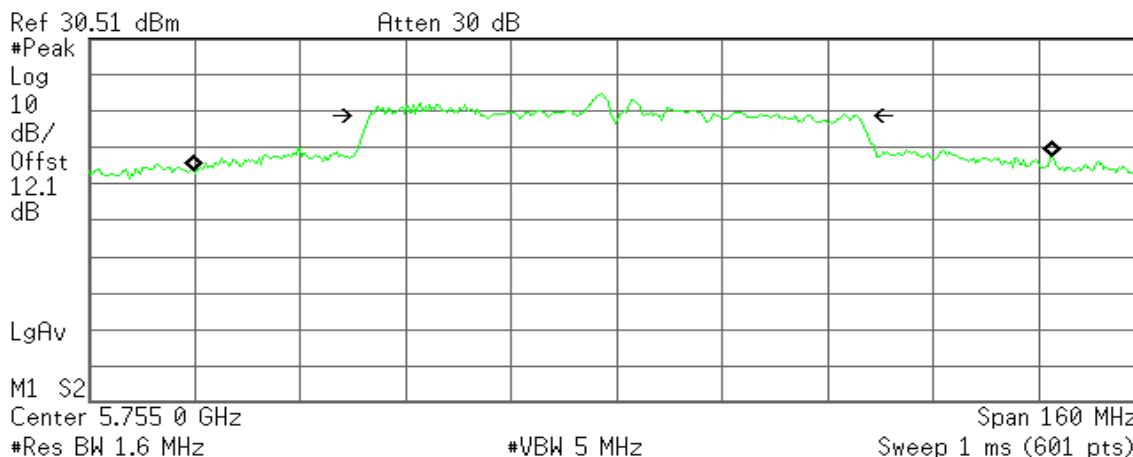

Occupied Bandwidth
 129.9228 MHz

Occ BW % Pwr 99.00 %
x dB -6.00 dB

Transmit Freq Error 1.057 MHz
x dB Bandwidth 74.191 MHz

IEEE 802.11ac VHT80 Mode / 5775MHz / Chain 1

CH Mid

Agilent

R T

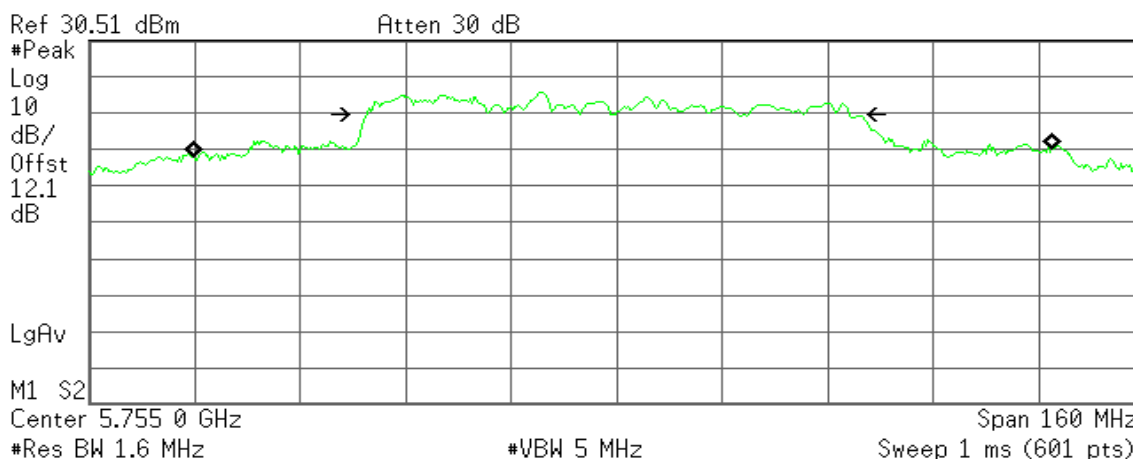

Occupied Bandwidth
 129.9630 MHz

Occ BW % Pwr 99.00 %
x dB -6.00 dB

Transmit Freq Error 1.021 MHz
x dB Bandwidth 73.386 MHz

7.2 MAXIMUM CONDUCTED OUTPUT POWER

Test Configuration

The EUT was connected to a spectrum analyzer through a 50Ω RF cable.

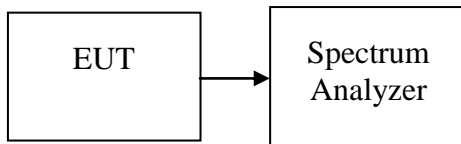

TEST PROCEDURE

Set span to encompass the entire emission bandwidth (EBW) of the signal.

Set RBW = 1 MHz / Set VBW = 3 MHz.

Use sample detector mode if bin width (i.e., span/number of points in spectrum display) < 0.5 RBW. Otherwise use peak detector mode. Use a video trigger with the trigger level set to enable triggering only on full power pulses. Transmitter must operate at full control power for entire sweep of every sweep. If the device transmits continuously, with no off intervals or reduced power intervals, the trigger may be set to “free run”. Trace average 100 traces in power averaging mode. Compute power by integrating the spectrum across the 26 dB EBW of the signal. The integration can be performed using the spectrum analyzer’s band power measurement function with band limits set equal to the EBW band edges or by summing power levels in each 1 MHz band in linear power terms. The 1 MHz band power levels to be summed can be obtained by averaging, in linear power terms, power levels in each frequency bin across the 1 MHz.

TEST RESULTS

No non-compliance noted

Test Data

Test mode: IEEE 802.11a mode / 5180 ~ 5240MHz

Channel	Frequency (MHz)	Maximum Conducted Output Power (dBm)	Limit (dBm)
Low	5180	19.47	30.00
Mid	5220	20.35	30.00
High	5240	20.11	30.00

Test mode: IEEE 802.11n HT 20 mode / 5180 ~ 5240MHz

Channel	Frequency (MHz)	Chain 0 Output Power (dBm)	Chain 1 Output Power (dBm)	Total Maximum Conducted Output Power (dBm)	Limit (dBm)
Low	5180	19.81	19.89	22.86	30.00
Mid	5220	19.65	19.91	22.80	30.00
High	5240	19.65	19.48	22.58	30.00

Test mode: IEEE 802.11n HT 40 mode / 5190 ~ 5230MHz

Channel	Frequency (MHz)	Chain 0 Output Power (dBm)	Chain 1 Output Power (dBm)	Total Maximum Conducted Output Power (dBm)	Limit (dBm)
Low	5190	14.61	14.03	17.34	30.00
High	5230	19.40	18.62	22.04	30.00

Test mode: IEEE 802.11ac VHT80 Mode / 5210MHz

Channel	Frequency (MHz)	Chain 0 Output Power (dBm)	Chain 1 Output Power (dBm)	Total Maximum Conducted Output Power (dBm)	Limit (dBm)
Mid	5210	15.23	16.32	18.82	30.00

Remark:

1. Total Output Power (w) = Chain 0 (10^{^(Output Power /10)}/1000) + Chain 1 (10^{^(Output Power /10)}/1000)

Test mode: IEEE 802.11a mode / 5745 ~ 5825MHz

Channel	Frequency (MHz)	Maximum Conducted Output Power (dBm)	Limit (dBm)
Low	5745	19.10	30.00
Mid	5785	19.80	30.00
High	5825	20.42	30.00

Test mode: IEEE 802.11n HT 20 mode / 5745~5825MHz

Channel	Frequency (MHz)	Chain 0 Output Power (dBm)	Chain 1 Output Power (dBm)	Total Maximum Conducted Output Power (dBm)	Limit (dBm)
Low	5745	20.07	19.35	22.74	30.00
Mid	5785	19.41	20.70	23.12	30.00
High	5825	18.60	19.27	21.96	30.00

Test mode: IEEE 802.11n HT 40 mode / 5755 ~ 5795MHz

Channel	Frequency (MHz)	Chain 0 Output Power (dBm)	Chain 1 Output Power (dBm)	Total Maximum Conducted Output Power (dBm)	Limit (dBm)
Low	5755	18.63	19.54	22.12	30.00
High	5795	19.22	20.04	22.66	30.00

Test mode: IEEE 802.11ac VHT80 Mode / 5775MHz

Channel	Frequency (MHz)	Chain 0 Output Power (dBm)	Chain 1 Output Power (dBm)	Total Maximum Conducted Output Power (dBm)	Limit (dBm)
Mid	5775	19.42	21.26	23.45	30.00

Remark:

1. Total Output Power (w) = Chain 0 (10^{^(Output Power /10)}/1000) + Chain 1 (10^{^(Output Power /10)}/1000)

7.3 BAND EDGES MEASUREMENT

LIMIT

According to §15.407(b),

- (1) The provisions of Section 15.205 of this part apply to intentional radiators operating under this section.
- (2) When measuring the emission limits, the nominal carrier frequency shall be adjusted as close to the upper and lower frequency block edges as the design of the equipment permits.

Test Configuration

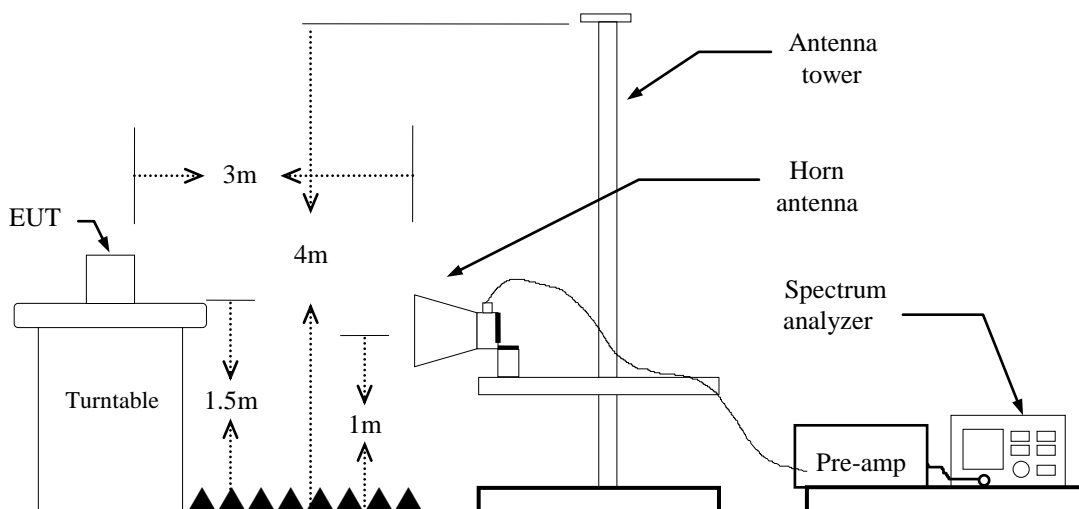

TEST PROCEDURE

1. The EUT is placed on a turntable, which is 1.5m above the ground plane.
2. The turntable shall be rotated for 360 degrees to determine the position of maximum emission level.
3. EUT is set 3m away from the receiving antenna, which is varied from 1m to 4m to find out the highest emission.
4. Set the spectrum analyzer in the following setting in order to capture the lower and upper band-edges of the emission:
 - (a) PEAK: RBW=VBW=3MHz / Sweep=AUTO
 - (b) AVERAGE: RBW=1MHz,
 - if duty cycle $\geq 98\%$, VBW=10Hz.
 - if duty cycle $< 98\%$ VBW=1/T.
 - IEEE 802.11b mode: $\geq 98\%$, VBW=10Hz
 - IEEE 802.11g mode: $\geq 98\%$, VBW=10Hz
 - IEEE 802.11n HT 20 MHz mode: $\geq 98\%$, VBW=10Hz
 - IEEE 802.11n HT 40 MHz mode: $\geq 98\%$ =VBW 10Hz
5. Repeat the procedures until all the PEAK and AVERAGE versus POLARIZATION are measured.

TEST RESULTS

Refer to attach spectrum analyzer data chart.

Band Edges (IEEE 802.11a mode / 5180 MHz)

Polarity: Vertical

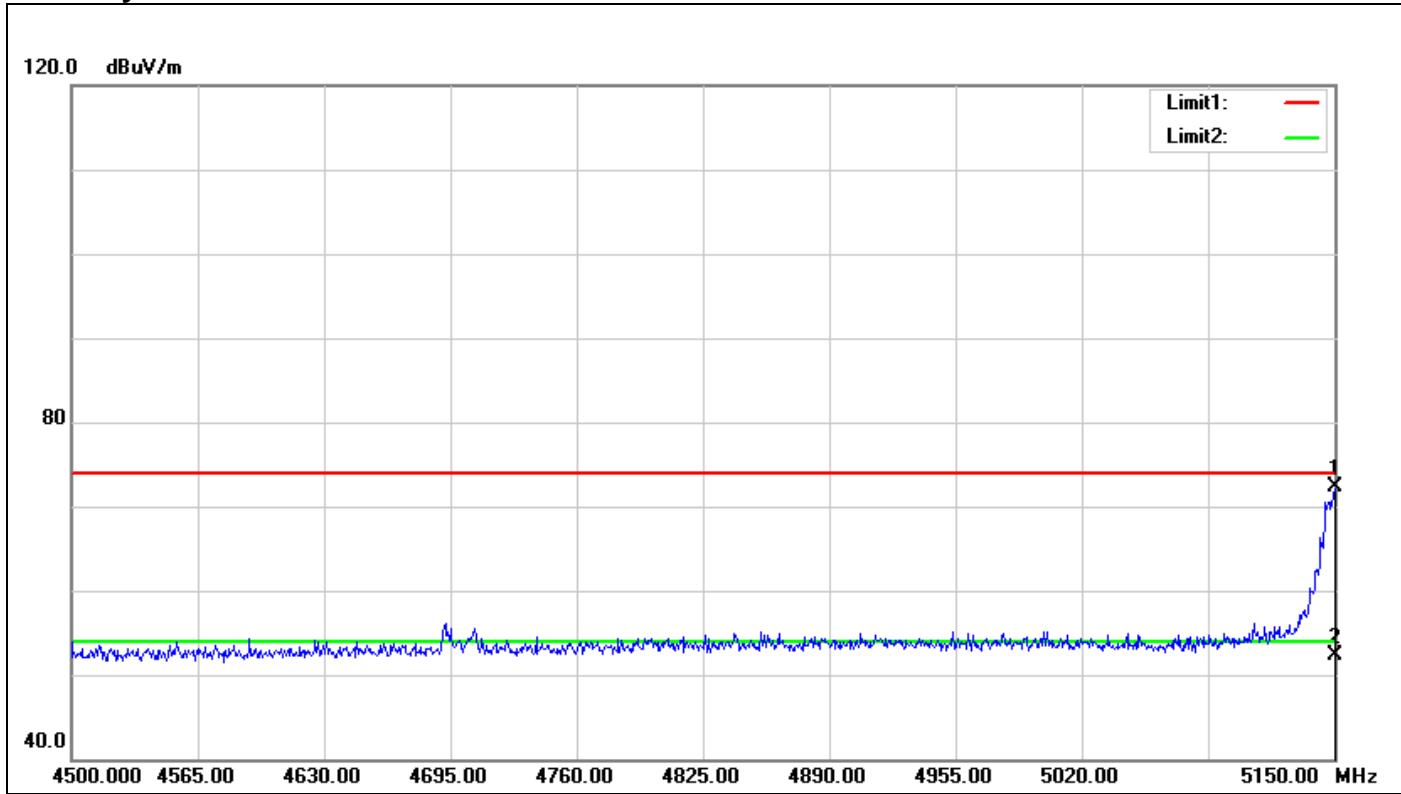

No.	Frequency (MHz)	Reading (dBuV)	Correct Factor(dB/m)	Result (dBuV/m)	Limit (dBuV/m)	Margin (dB)	Height (cm)	Degree (°)	Remark
1	5150.000	69.35	3.04	72.39	74.00	-1.61	100	90	peak
2	5150.000	49.29	3.04	52.33	54.00	-1.67	100	90	AVG

Polarity: Horizontal

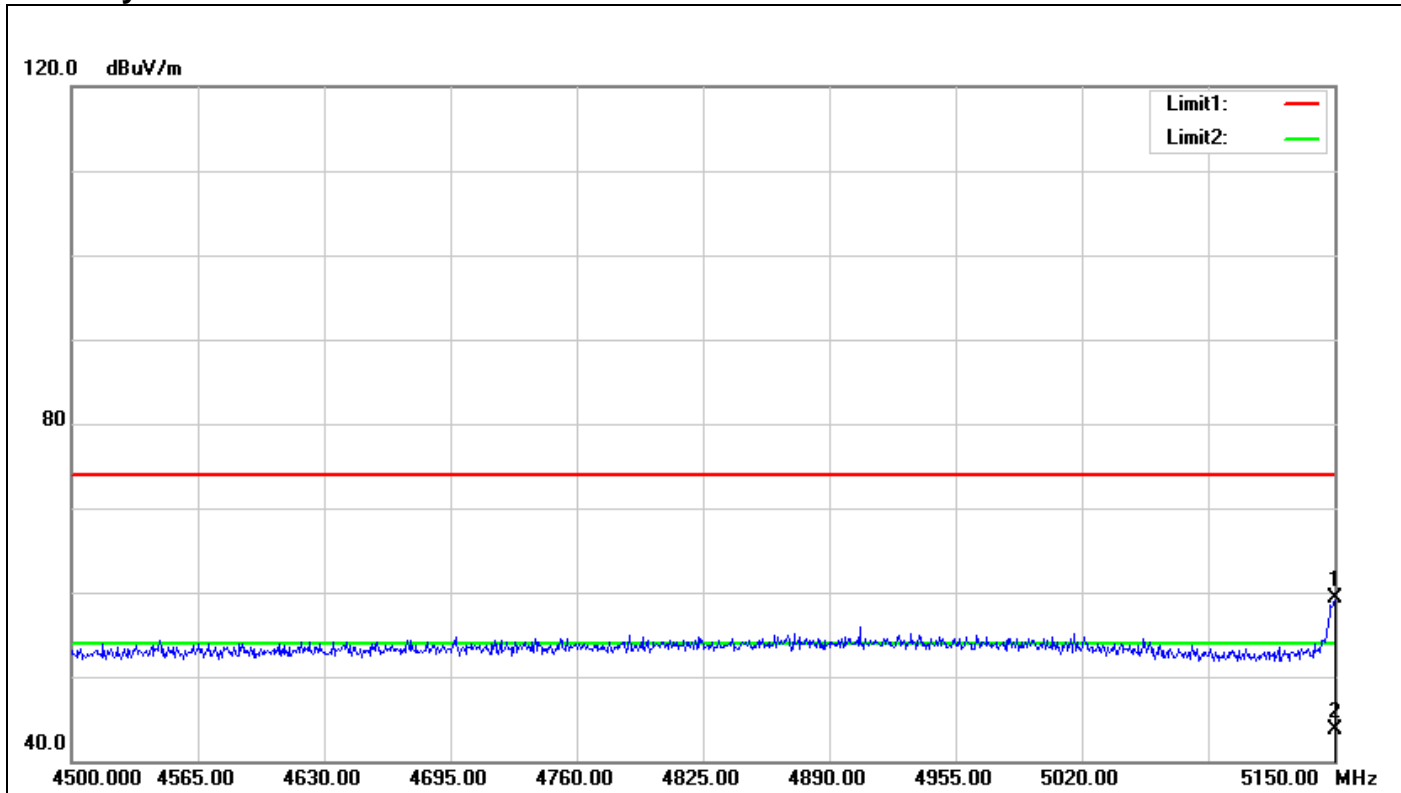

No.	Frequency (MHz)	Reading (dBuV)	Correct Factor(dB/m)	Result (dBuV/m)	Limit (dBuV/m)	Margin (dB)	Height (cm)	Degree (°)	Remark
1	5150.000	56.22	3.04	59.26	74.00	-14.74	100	23	peak
2	5150.000	40.73	3.04	43.77	54.00	-10.23	100	23	AVG

Band Edges (IEEE 802.11n HT 20 mode / 5180 MHz)

Polarity: Vertical

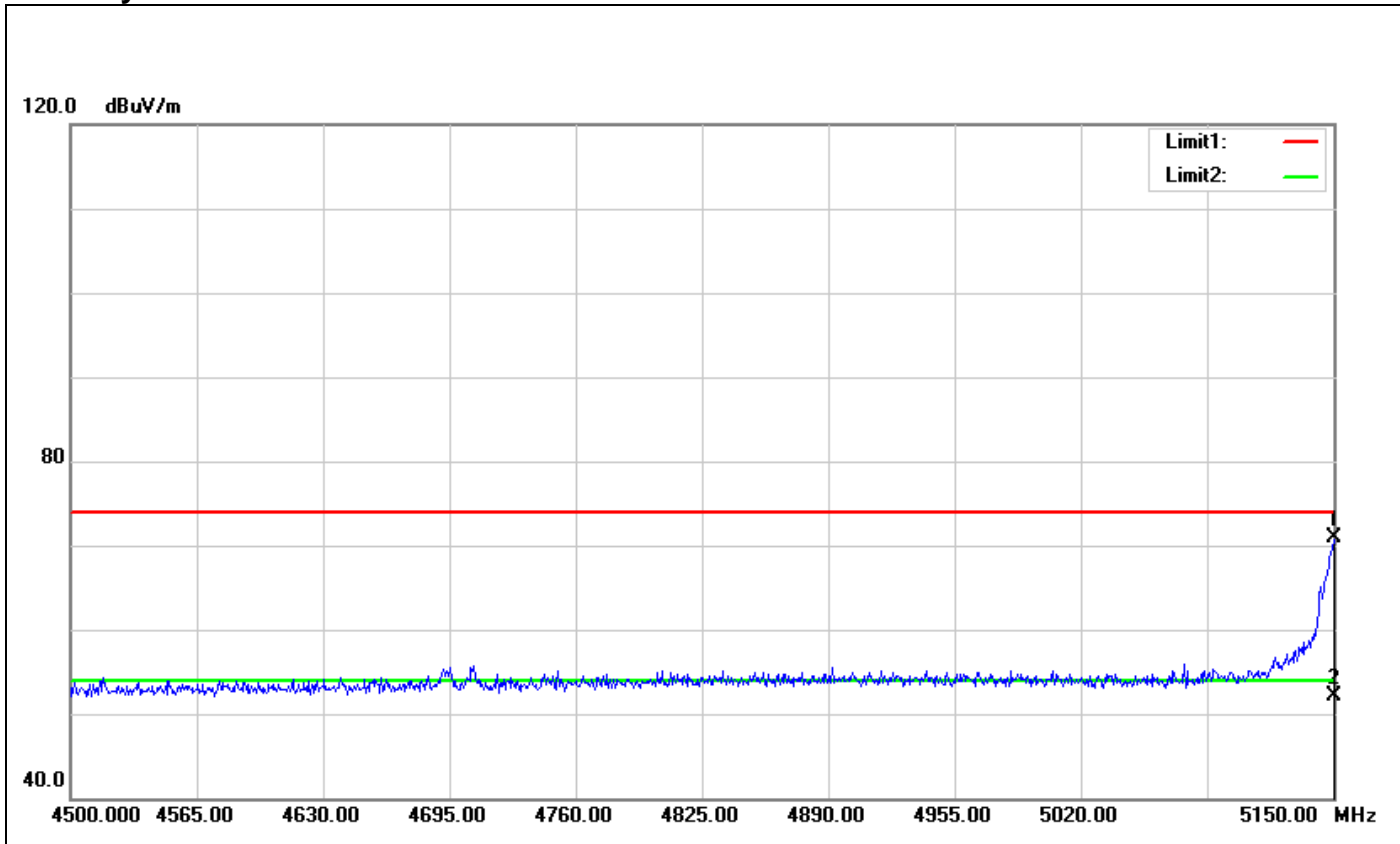

No.	Frequency (MHz)	Reading (dBuV)	Correct Factor(dB/m)	Result (dBuV/m)	Limit (dBuV/m)	Margin (dB)	Height (cm)	Degree (°)	Remark
1	5150.000	67.80	3.04	70.84	74.00	-3.16	100	9	peak
2	5150.000	48.99	3.04	52.03	54.00	-1.97	100	9	AVG

Polarity: Horizontal

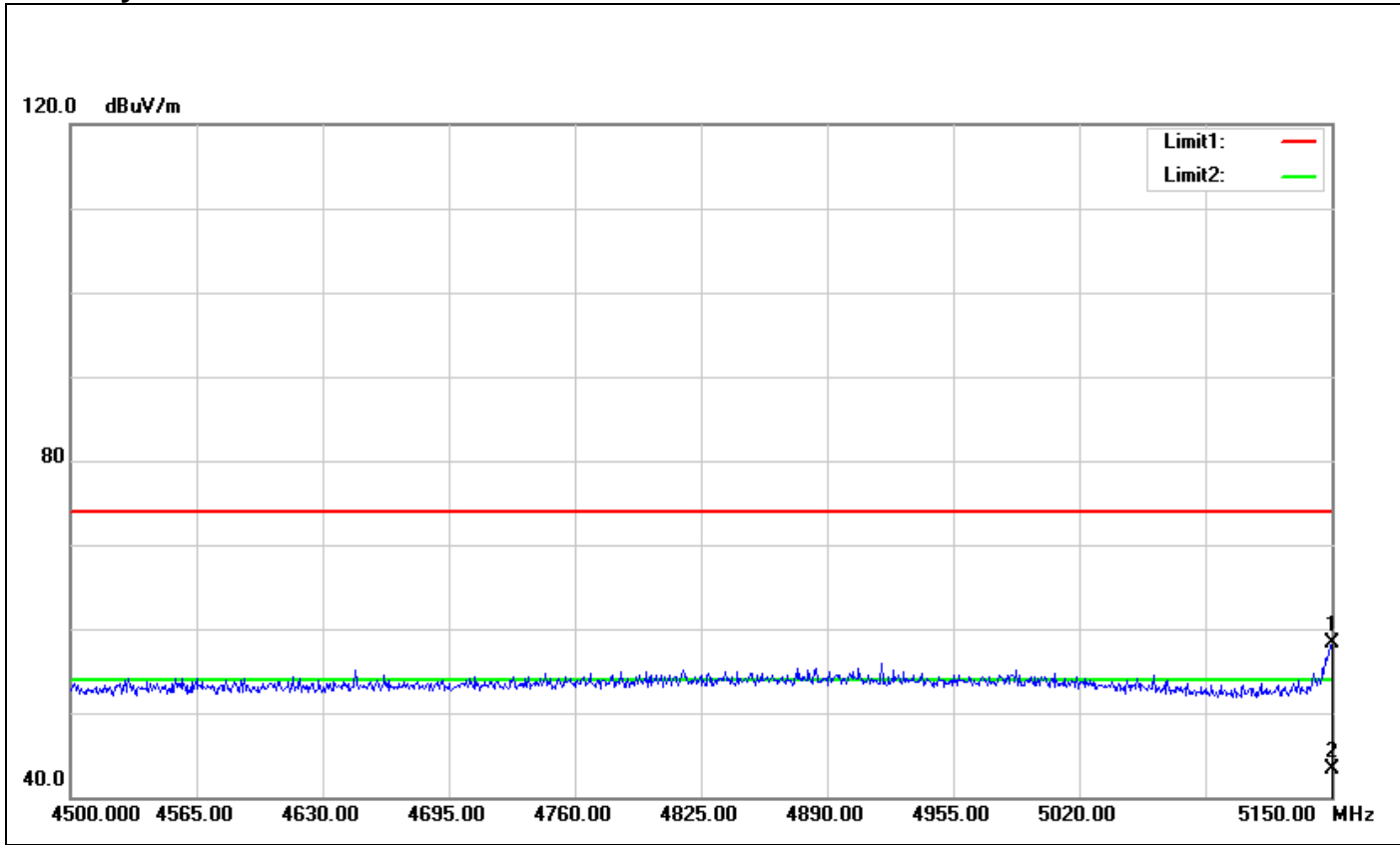

No.	Frequency (MHz)	Reading (dBuV)	Correct Factor(dB/m)	Result (dBuV/m)	Limit (dBuV/m)	Margin (dB)	Height (cm)	Degree (°)	Remark
1	5150.000	55.24	3.04	58.28	74.00	-15.72	100	93	peak
2	5150.000	40.22	3.04	43.26	54.00	-10.74	100	93	AVG

Band Edges (IEEE 802.11n HT 40 mode / 5190 MHz)

Polarity: Vertical

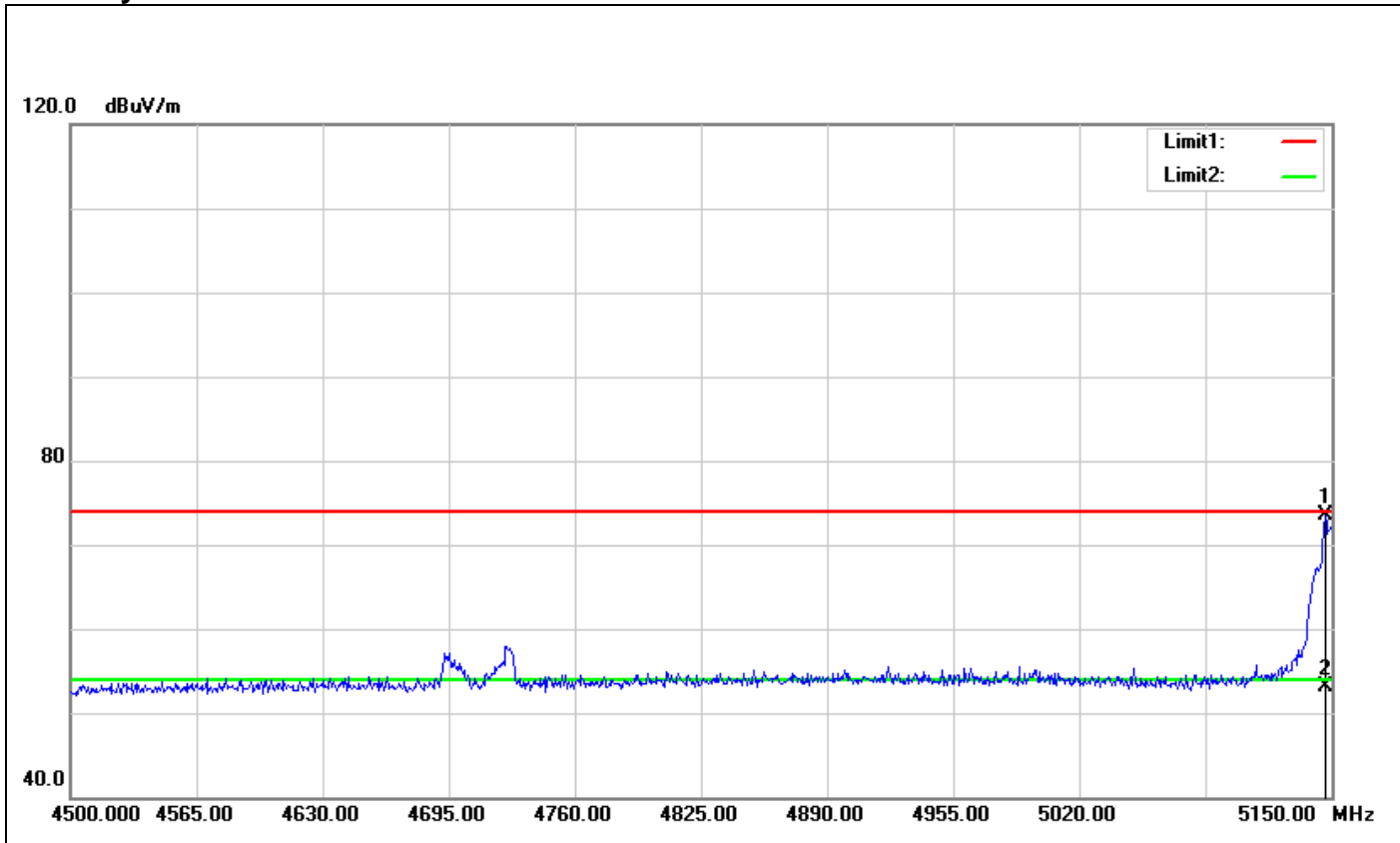

No.	Frequency (MHz)	Reading (dBuV)	Correct Factor(dB/m)	Result (dBuV/m)	Limit (dBuV/m)	Margin (dB)	Height (cm)	Degree (°)	Remark
1	5146.750	70.47	3.02	73.49	74.00	-0.51	100	90	peak
2	5146.750	50.12	3.02	53.14	54.00	-0.86	100	90	AVG

Polarity: Horizontal

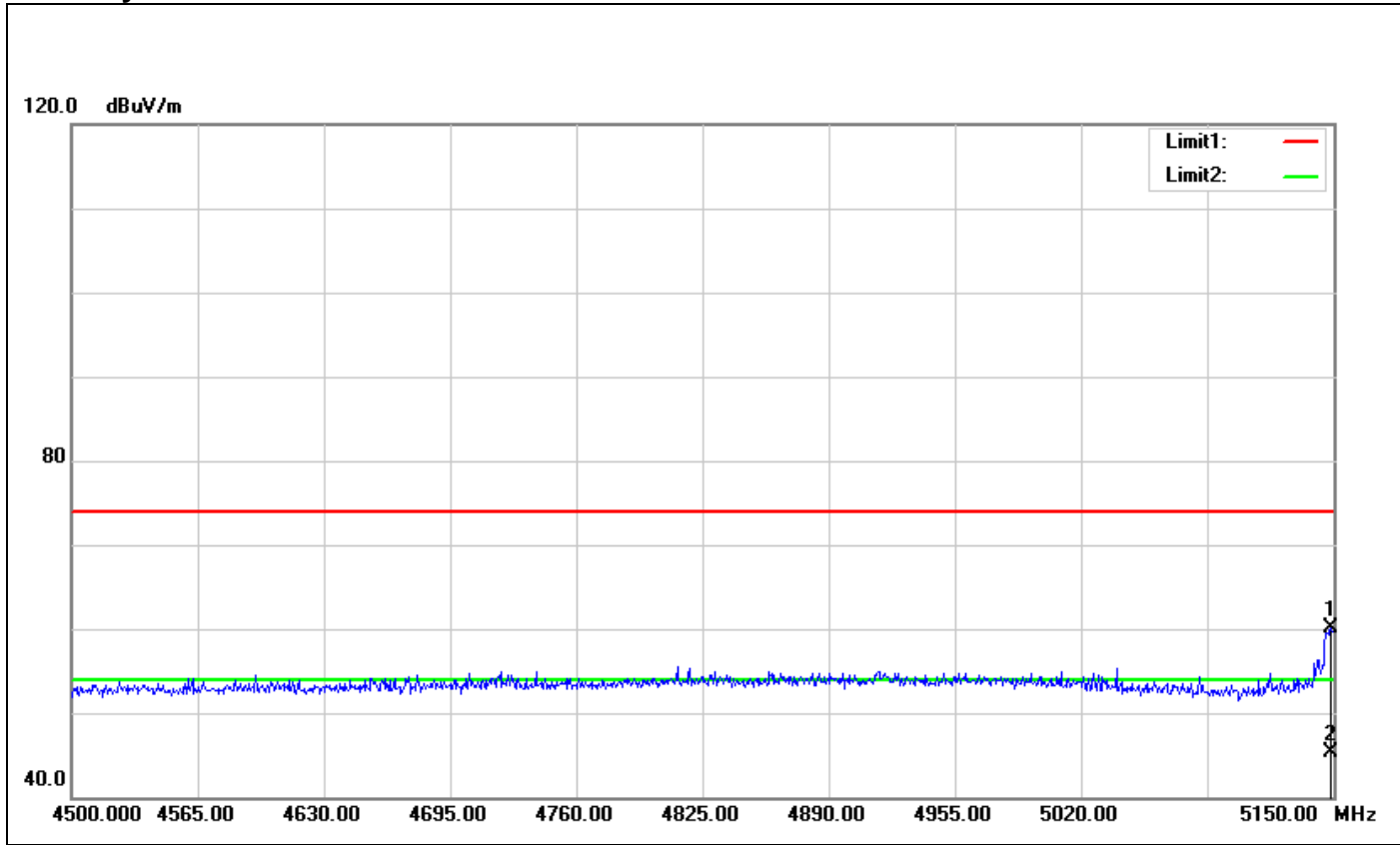

No.	Frequency (MHz)	Reading (dBuV)	Correct Factor(dB/m)	Result (dBuV/m)	Limit (dBuV/m)	Margin (dB)	Height (cm)	Degree (°)	Remark
1	5148.700	57.05	3.03	60.08	74.00	-13.92	100	230	peak
2	5148.700	42.33	3.03	45.36	54.00	-8.64	100	230	AVG

Band Edges (IEEE 802.11ac VHT80 Mode / CH 5210 MHz)

Polarity: Vertical

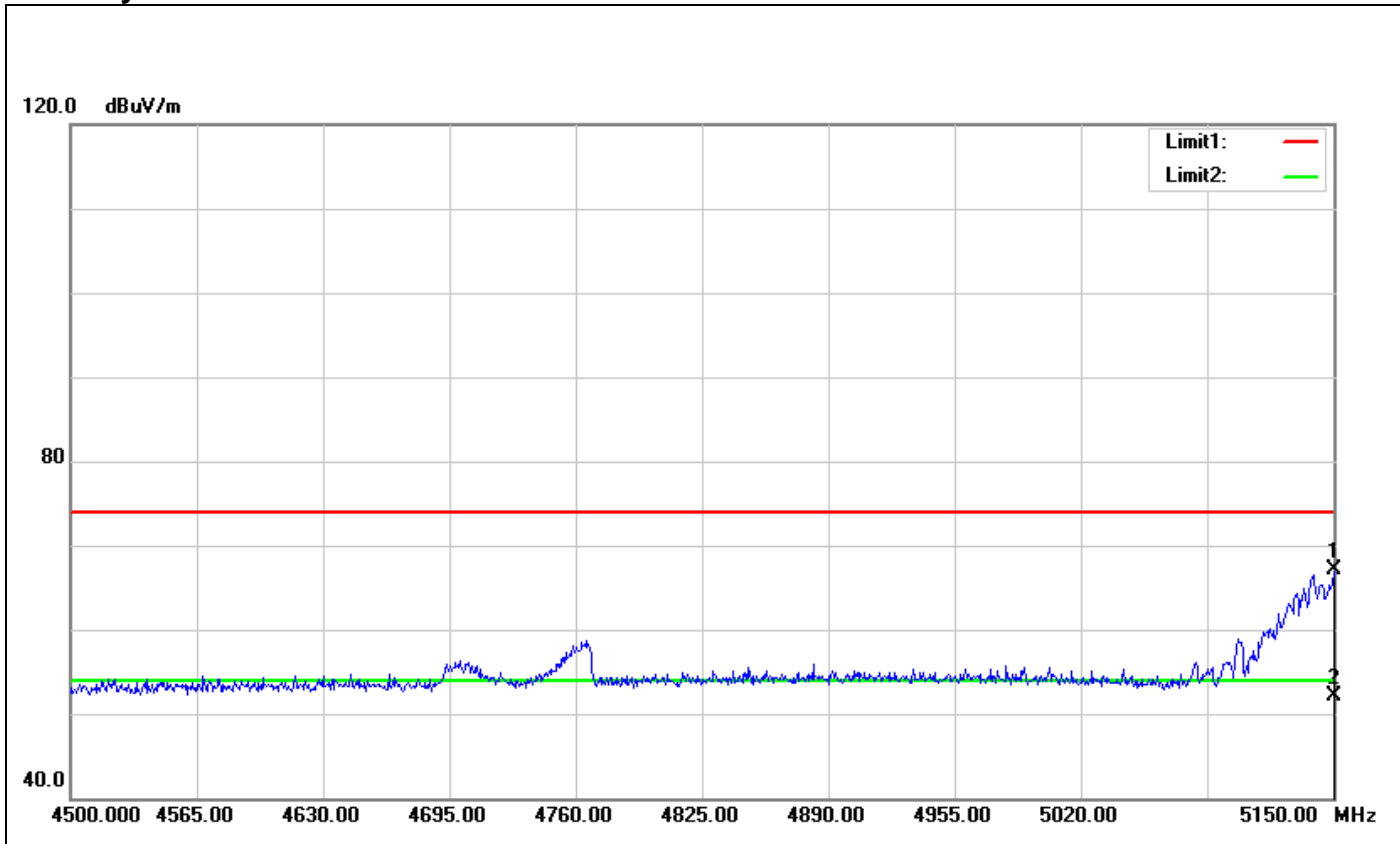

No.	Frequency (MHz)	Reading (dBuV)	Correct Factor(dB/m)	Result (dBuV/m)	Limit (dBuV/m)	Margin (dB)	Height (cm)	Degree (°)	Remark
1	5150.000	63.97	3.04	67.01	74.00	-6.99	100	226	peak
2	5150.000	48.99	3.04	52.03	54.00	-1.97	100	226	AVG

Polarity: Horizontal

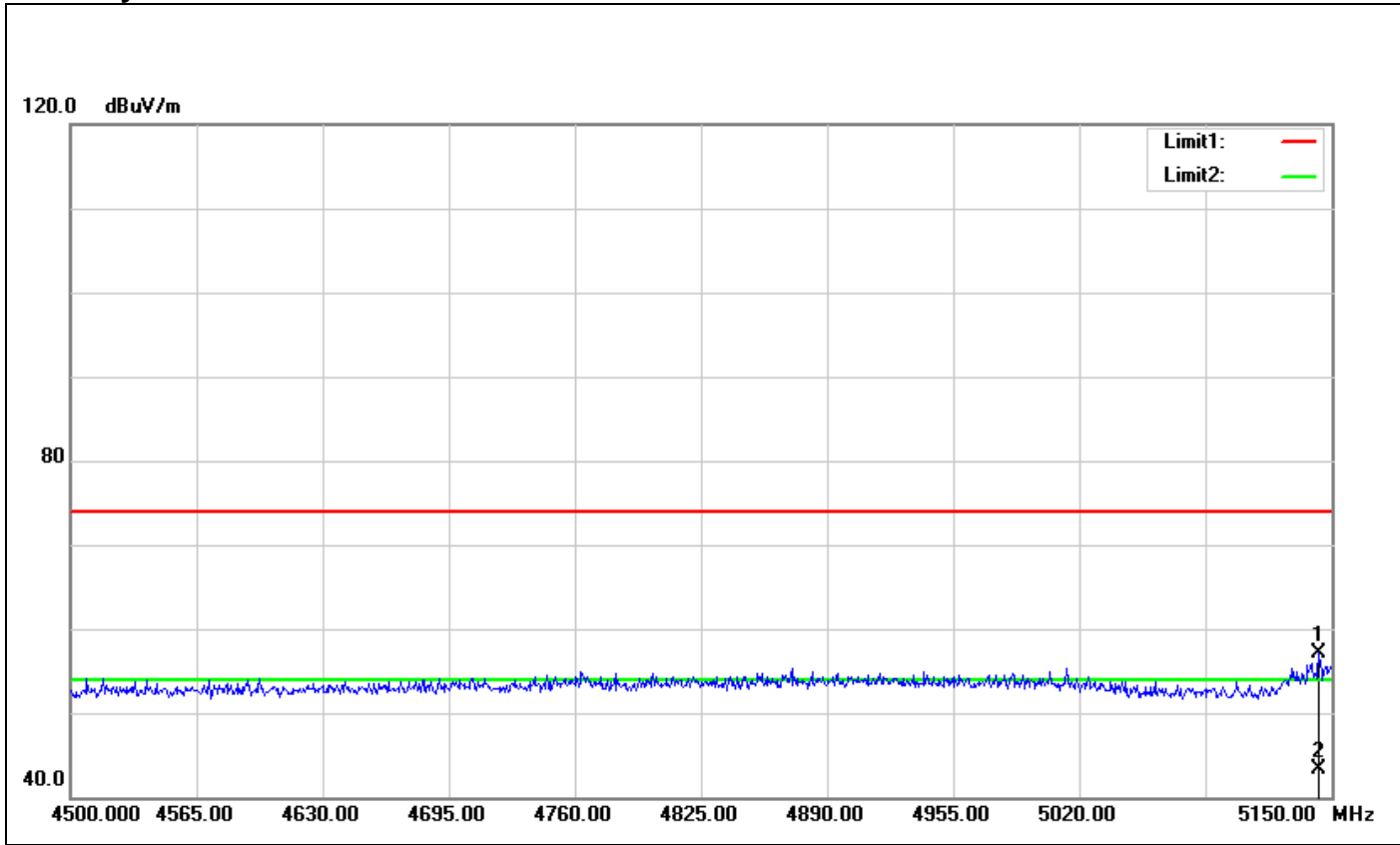

No.	Frequency (MHz)	Reading (dBuV)	Correct Factor(dB/m)	Result (dBuV/m)	Limit (dBuV/m)	Margin (dB)	Height (cm)	Degree (°)	Remark
1	5143.500	54.08	3.00	57.08	74.00	-16.92	100	223	peak
2	5143.500	40.30	3.00	43.30	54.00	-10.70	100	223	AVG

7.4 PEAK POWER SPECTRAL DENSITY

LIMIT

According to §15.407(a),

- (1) For the band 5.15-5.25 GHz, the peak power spectral density shall not exceed 17dBm in any 1MHz band.
- (2) For the band 5.47-5.725 GHz bands, the peak power spectral density shall not exceed 30dBm in any 500KHz band.

If transmitting antennas of directional gain greater than 6dBi are used, both the peak transmit power and the peak power spectral density shall be reduced by the amount in dB that the directional gain of the antenna exceeds 6dBi.

Test Configuration

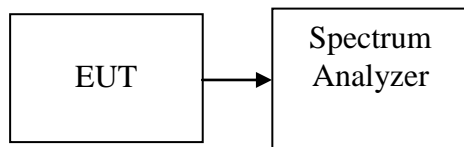

TEST PROCEDURE

1. Place the EUT on the table and set it in transmitting mode.
Remove the antenna from the EUT and then connect a low loss RF cable from the antenna port to the spectrum analyzer.
2. Set the spectrum analyzer as RBW = 1MHz, VBW = 3MHz, Span = Sweep= AUTO
3. Record the max. reading.
4. Repeat the above procedure until the measurements for all frequencies are completed

TEST RESULTS

No non-compliance noted

Test Data

Test mode: IEEE 802.11a mode / 5180 ~ 5240MHz

Channel	Frequency (MHz)	PPSD (dBm)	Limit (dBm)	Result
Low	5180	9.59	17.00	PASS
Mid	5220	9.06	17.00	PASS
High	5240	9.32	17.00	PASS

Test mode: IEEE 802.11n HT 20 mode / 5180 ~ 5240MHz

Channel	Frequency (MHz)	Chain 0 PPSD (dBm)	Chain 1 PPSD (dBm)	PPSD (dBm)	Limit (dBm)	Result
Low	5180	8.91	10.23	12.63	17.00	PASS
Mid	5220	8.19	10.07	12.24	17.00	PASS
High	5240	7.22	8.47	10.90	17.00	PASS

Test mode: IEEE 802.11n HT 40 mode / 5190 ~ 5230MHz

Channel	Frequency (MHz)	Chain 0 PPSD (dBm)	Chain 1 PPSD (dBm)	PPSD (dBm)	Limit (dBm)	Result
Low	5190	2.04	4.95	6.74	17.00	PASS
High	5230	5.26	6.95	9.20	17.00	PASS

Test mode: IEEE 802.11ac VHT80 Mode / 5210MHz

Channel	Frequency (MHz)	Chain 0 PPSD (dBm)	Chain 1 PPSD (dBm)	PPSD (dBm)	Limit (dBm)	Result
Mid	5210	-2.48	-1.64	0.97	16.12	PASS

Remark:

1. Total PPSD (dBm) = $10 \cdot \text{LOG}(10^{\text{Chain 0 PPSD} / 10} + 10^{\text{Chain 1 PPSD} / 10})$
2. The maximum antenna gain is 6.88dBi; therefore the reduction due to antenna gain is 0.88dB, so the limit is 16.12dBm.

Test mode: IEEE 802.11a mode/ 5745 ~ 5825MHz

Channel	Frequency (MHz)	PPSD (dBm)	Limit (dBm)	Result
Low	5745	5.37	30.00	PASS
Mid	5785	6.31	30.00	PASS
High	5825	6.18	30.00	PASS

Test mode: IEEE 802.11n HT 20 mode / 5745 ~ 5825MHz

Channel	Frequency (MHz)	Chain 0 PPSD (dBm)	Chain 1 PPSD (dBm)	PPSD (dBm)	Limit (dBm)	Result
Low	5745	5.18	7.80	9.69	29.12	PASS
Mid	5785	5.57	8.00	9.96	29.12	PASS
High	5825	4.45	7.56	9.29	29.12	PASS

Test mode: IEEE 802.11n HT 40 mode / 5755 ~ 5795MHz

Channel	Frequency (MHz)	Chain 0 PPSD (dBm)	Chain 1 PPSD (dBm)	PPSD (dBm)	Limit (dBm)	Result
Low	5755	2.31	4.89	6.80	29.12	PASS
High	5795	2.74	5.06	7.06	29.12	PASS

Test mode: IEEE 802.11ac VHT80 Mode / 5775MHz

Channel	Frequency (MHz)	Chain 0 PPSD (dBm)	Chain 1 PPSD (dBm)	PPSD (dBm)	Limit (dBm)	Result
Mid	5775	-0.73	1.36	3.45	29.12	PASS

Remark:

1. Total PPSD (dBm) = $10 \cdot \text{LOG}(10^{\text{Chain 0 PPSD} / 10} + 10^{\text{Chain 1 PPSD} / 10})$
2. The maximum antenna gain is 6.88dBi; therefore the reduction due to antenna gain is 0.88dB, so the limit is 29.12dBm.

Test Plot
IEEE 802.11a mode / 5180 ~ 5240MHz

CH Low

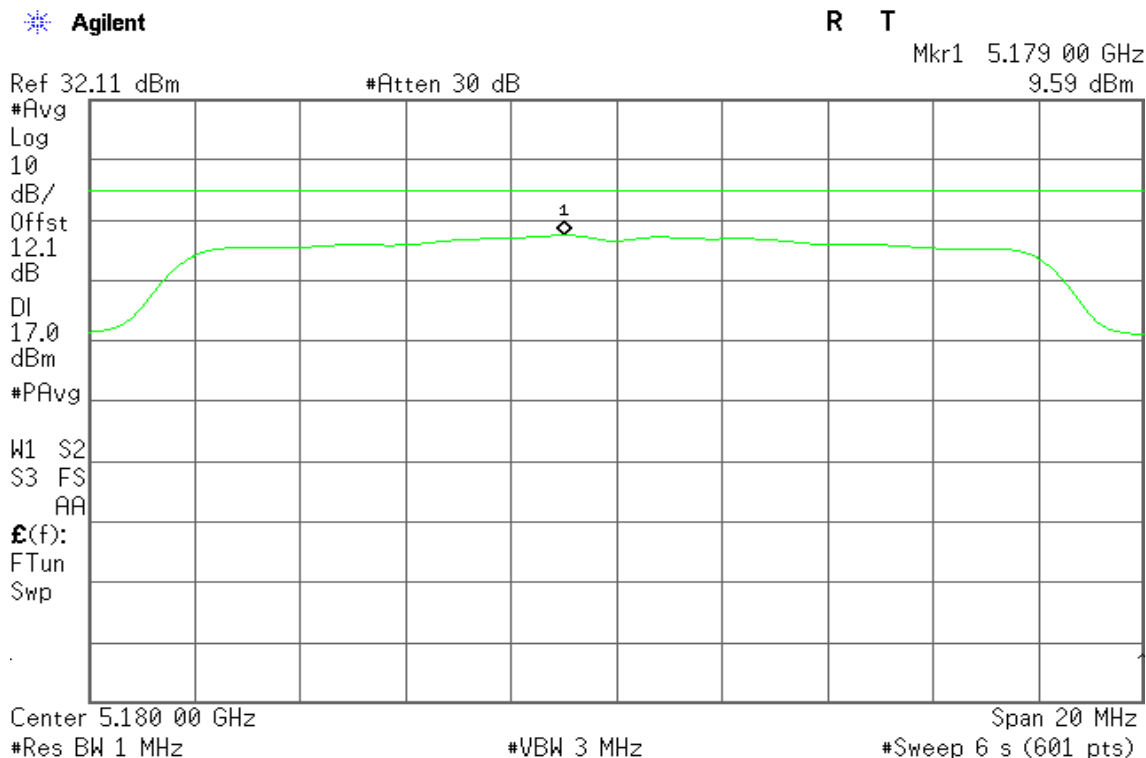

CH Mid

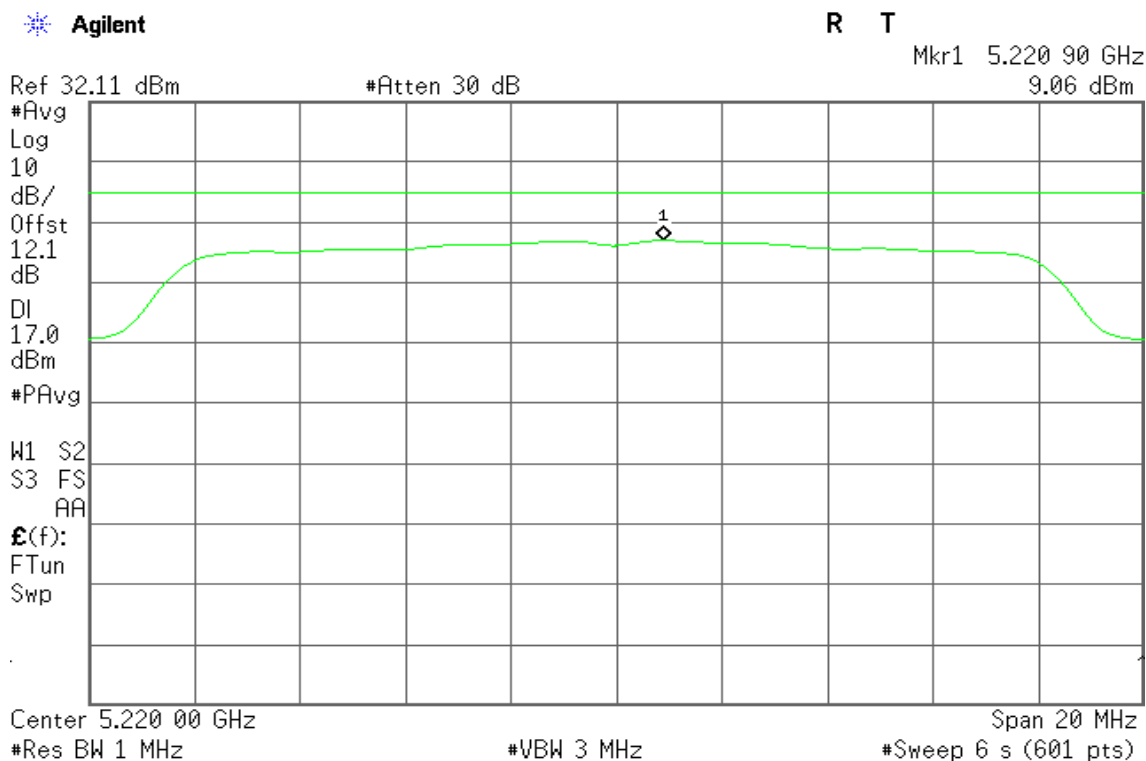

CH High

Agilent

R T

Mkr1 5.240 87 GHz
 9.32 dBm

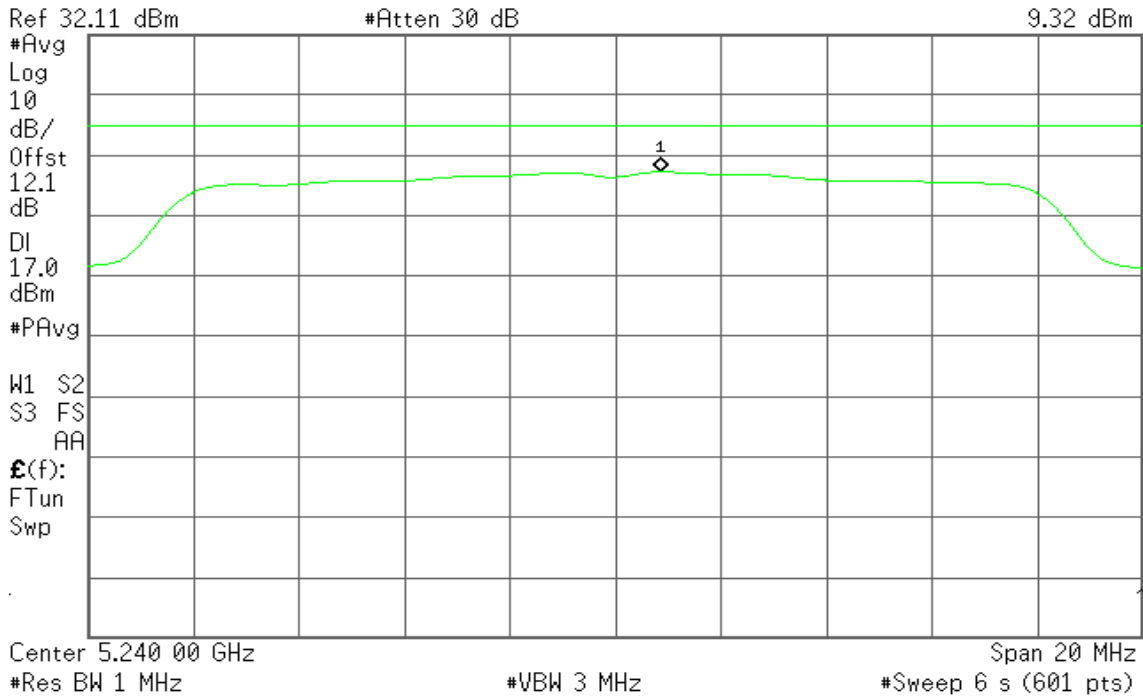

IEEE 802.11n HT 20 mode / 5180 ~ 5240MHz / Chain 0

CH Low

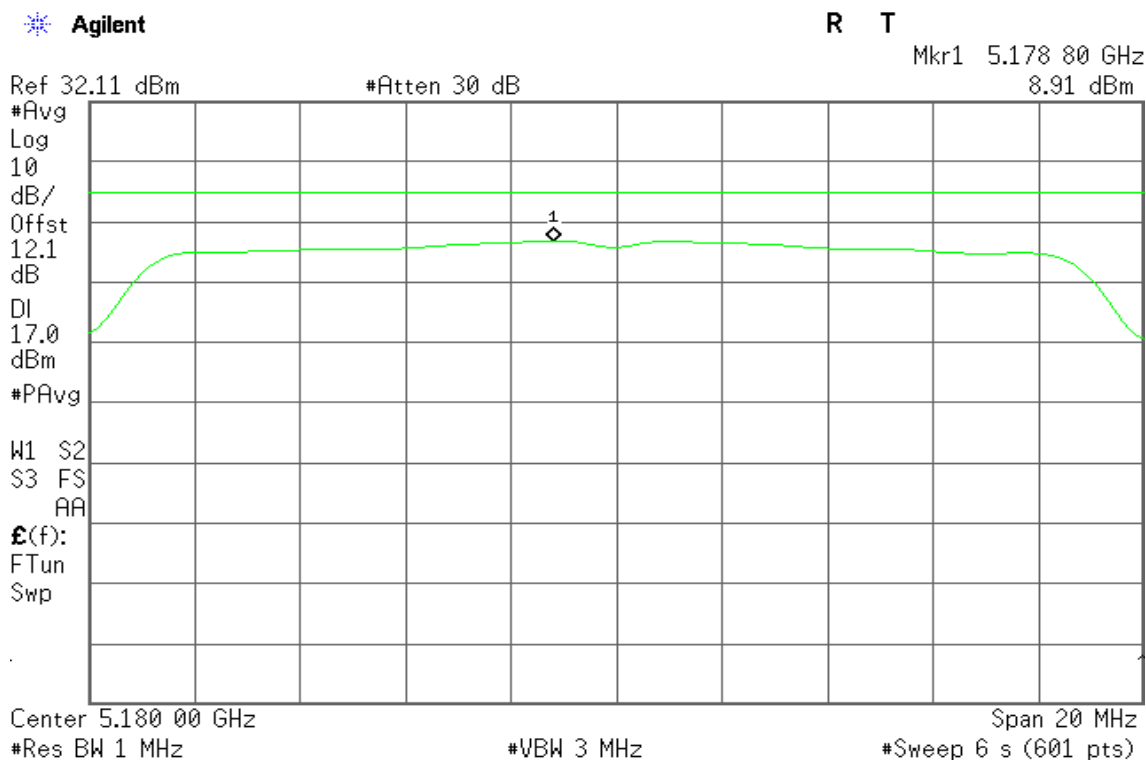

CH Mid

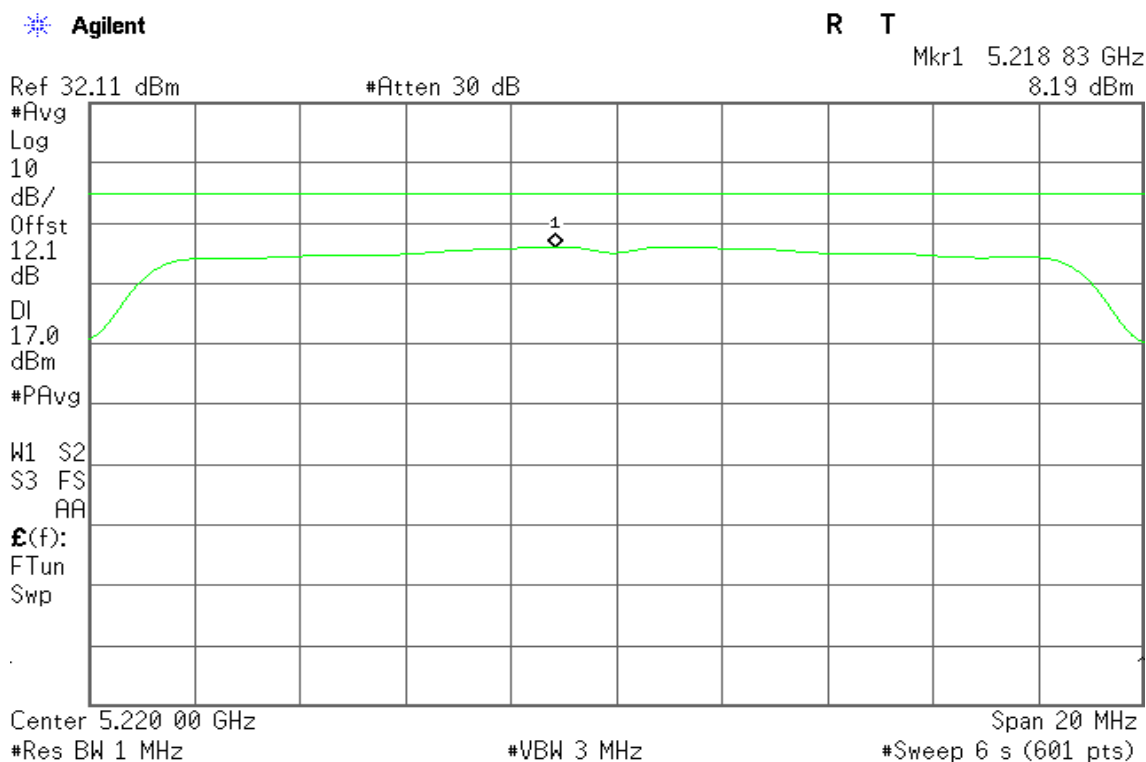

CH High

Agilent

R T

Mkr1 5.238 83 GHz
 7.22 dBm

Ref 32.11 dBm

#Atten 30 dB

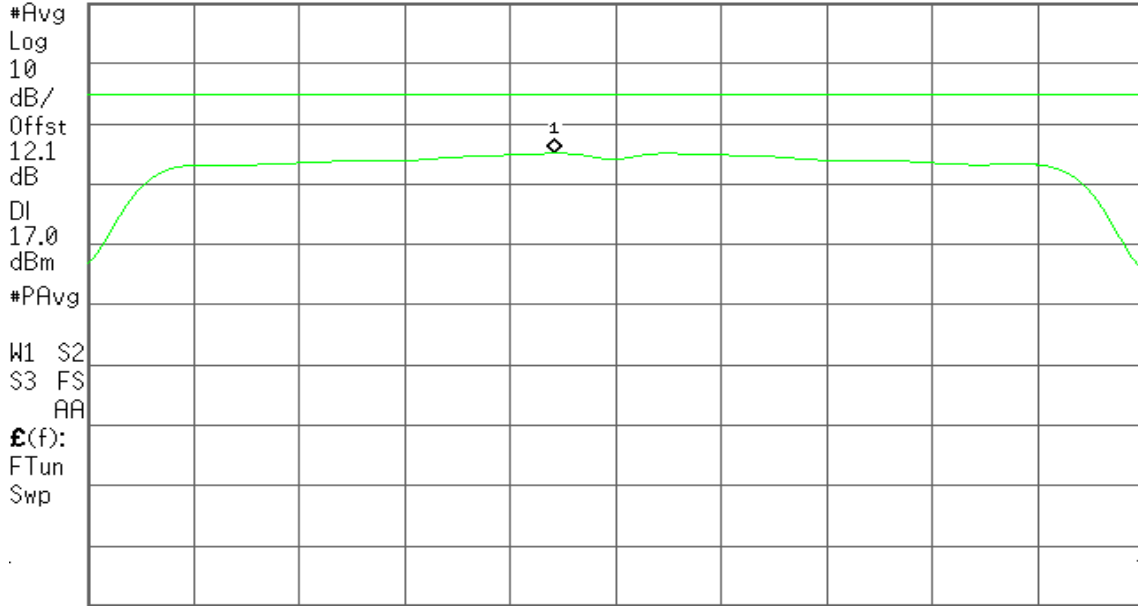

Center 5.240 00 GHz

#Res BW 1 MHz

#VBW 3 MHz

Span 20 MHz

#Sweep 6 s (601 pts)

IEEE 802.11n HT 20 mode / 5180 ~ 5240MHz / Chain 1

CH Low

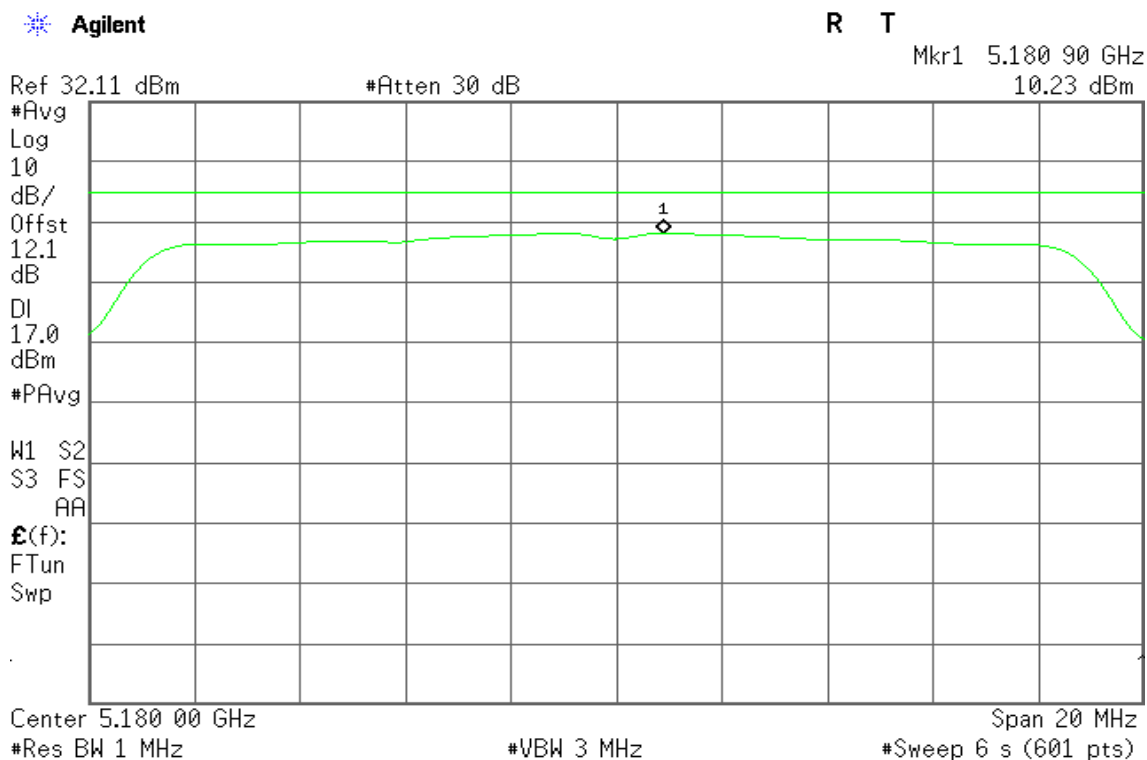

CH Mid

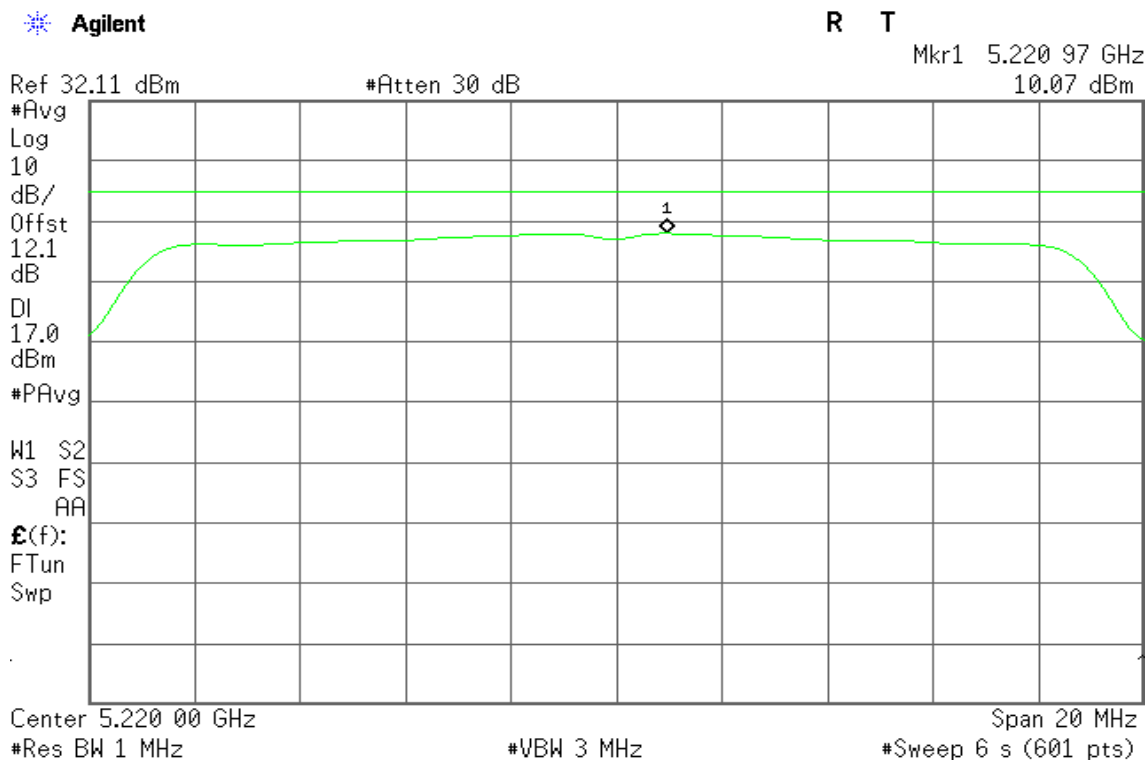

CH High

Agilent

R T

Mkr1 5.240 93 GHz
 8.47 dBm

Ref 32.11 dBm

#Atten 30 dB

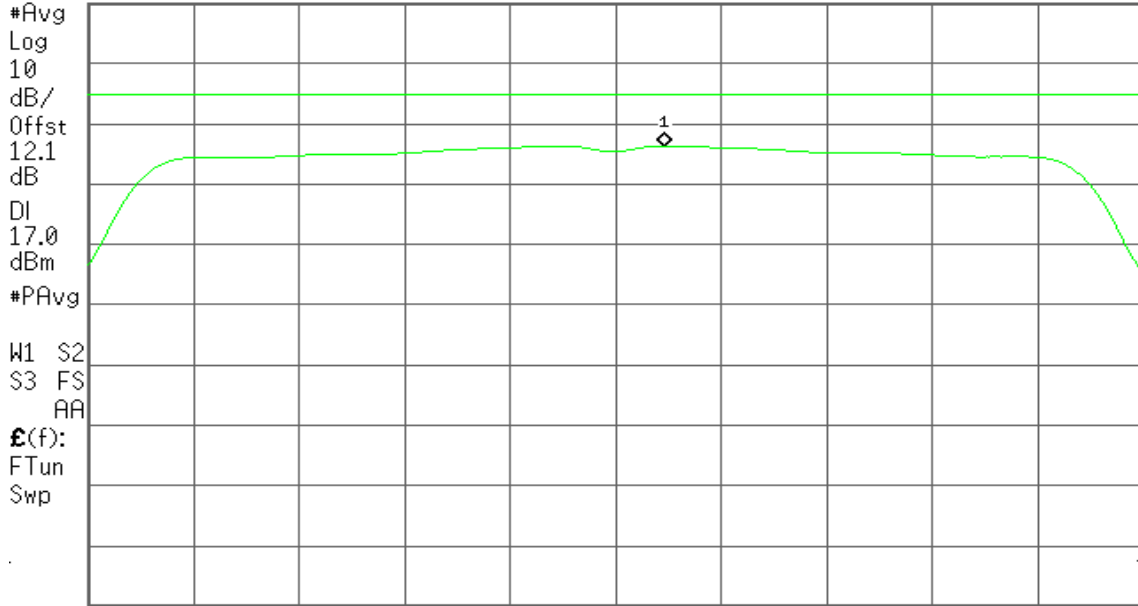

Center 5.240 00 GHz

#Res BW 1 MHz

#VBW 3 MHz

Span 20 MHz

#Sweep 6 s (601 pts)

IEEE 802.11n HT 40 mode / 5190 ~ 5230MHz / Chain 0

CH Low

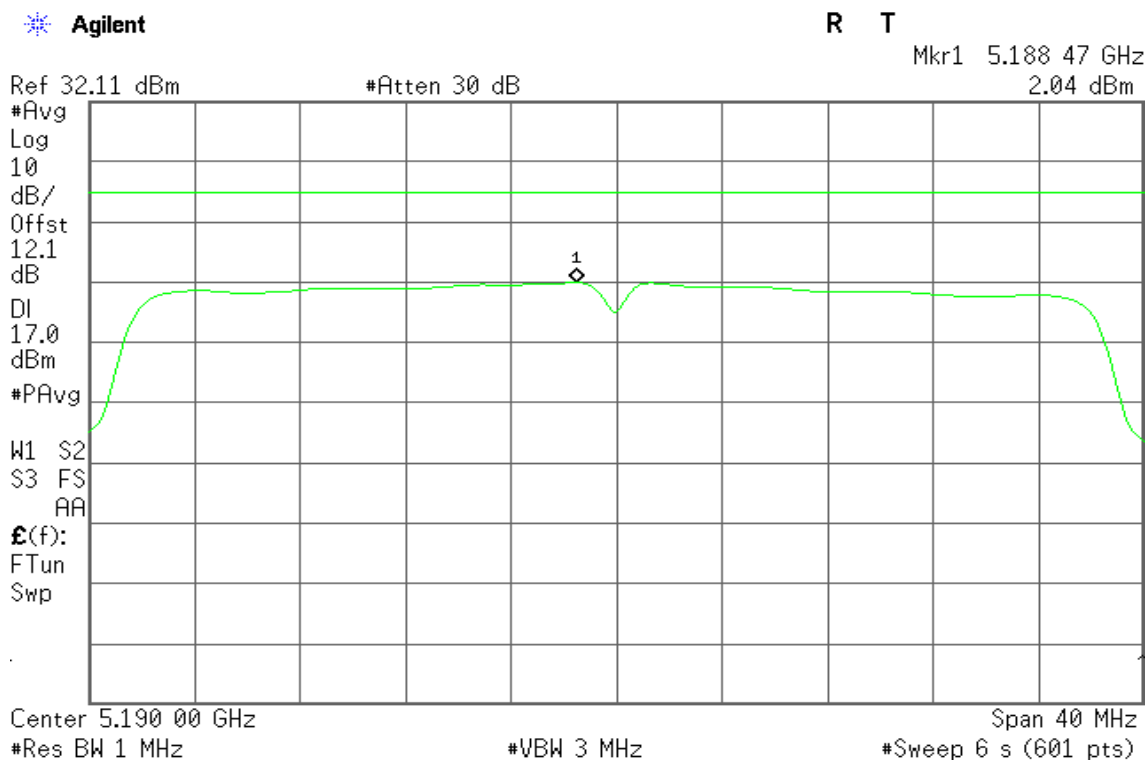

CH High

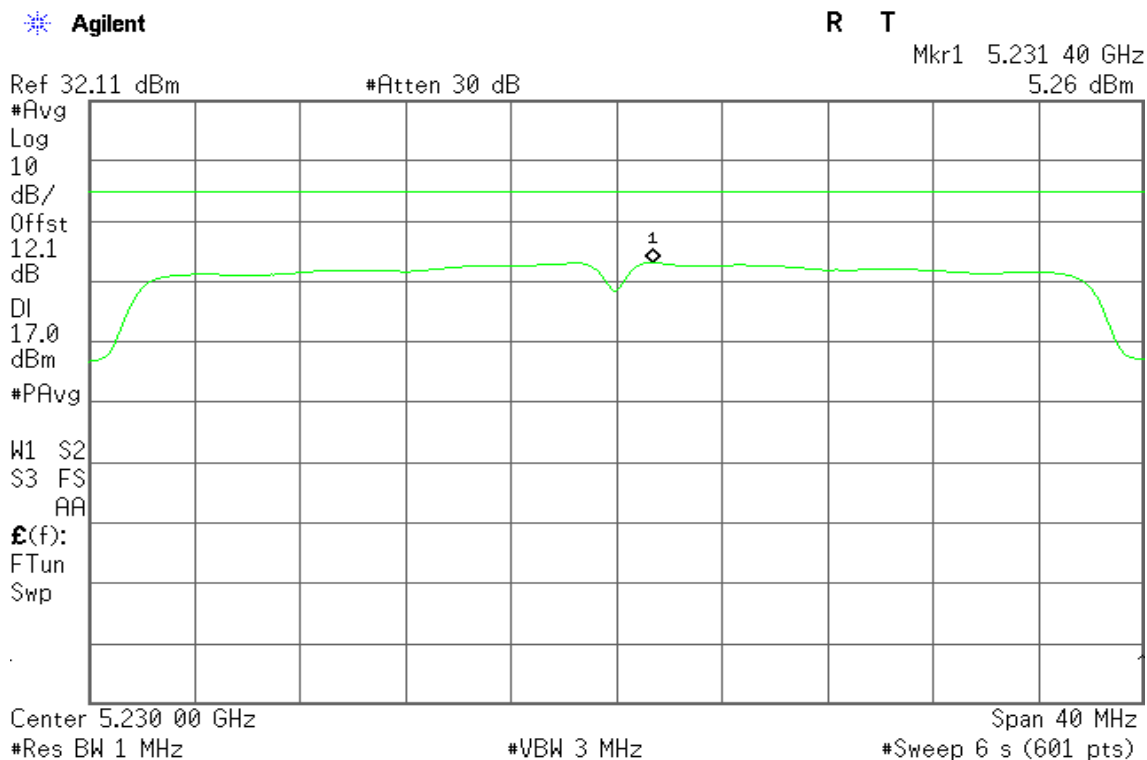

IEEE 802.11n HT 40 mode / 5190 ~ 5230MHz / Chain 1

CH Low

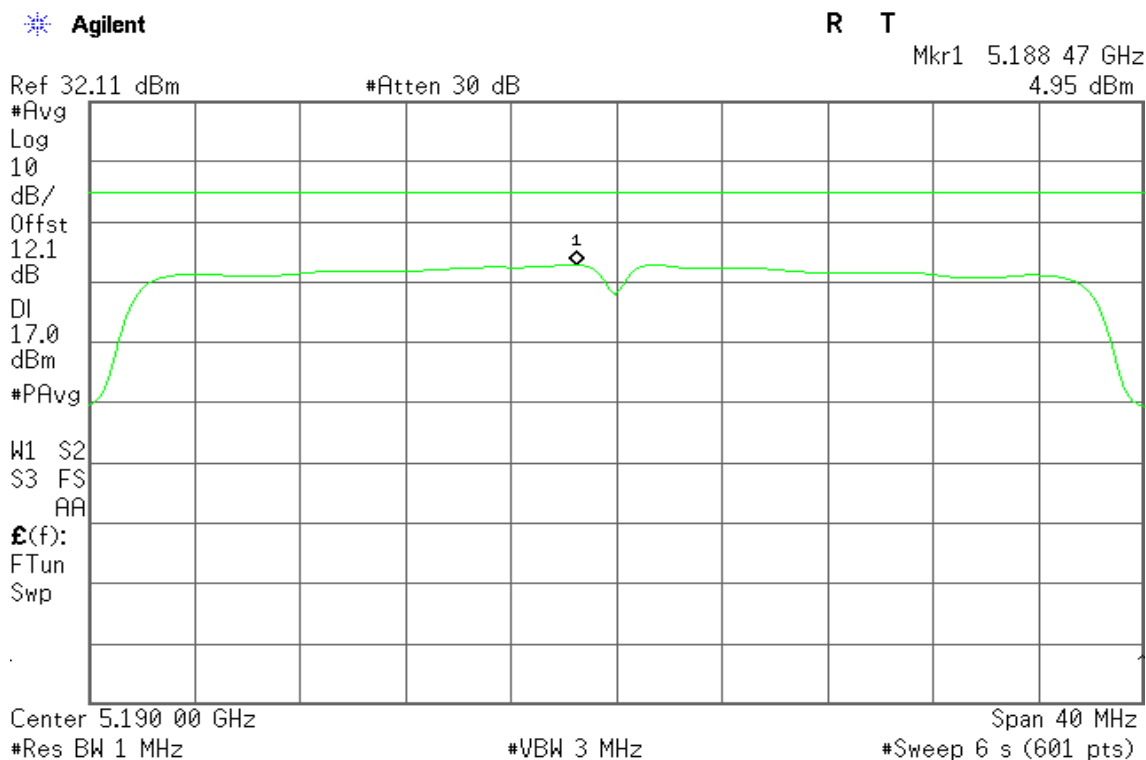

CH High

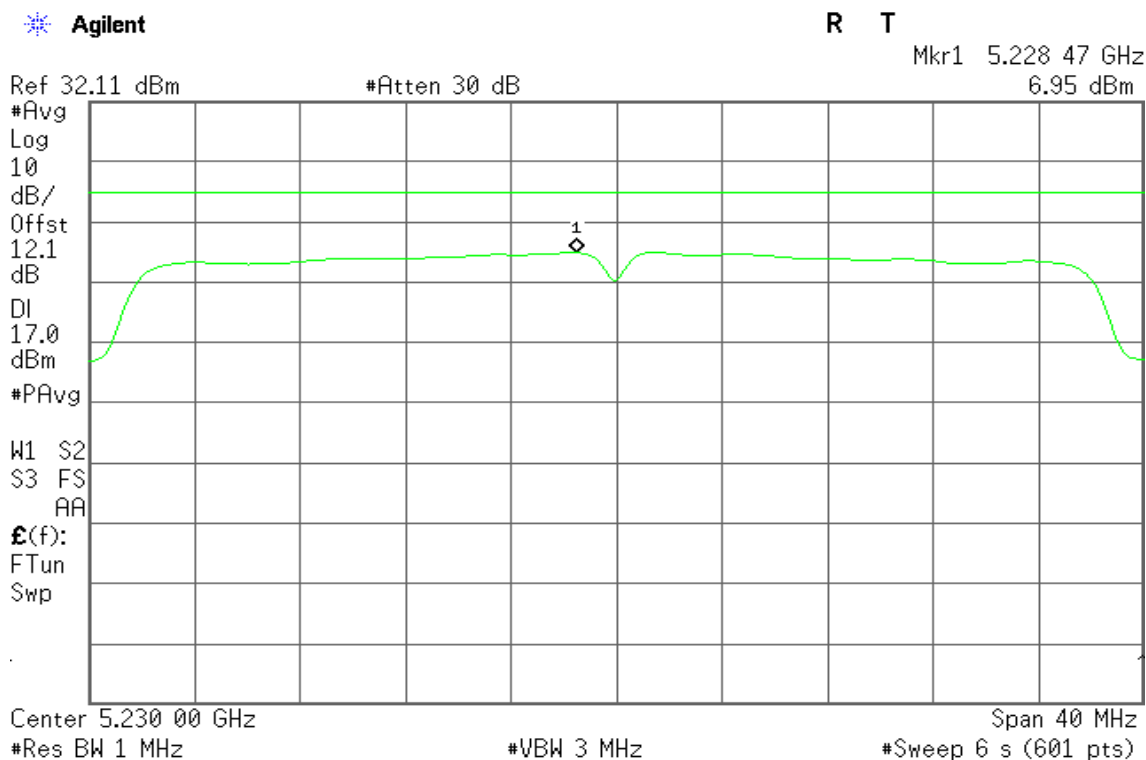

IEEE 802.11ac VHT80 Mode / 5210MHz / Chain 0

CH Mid

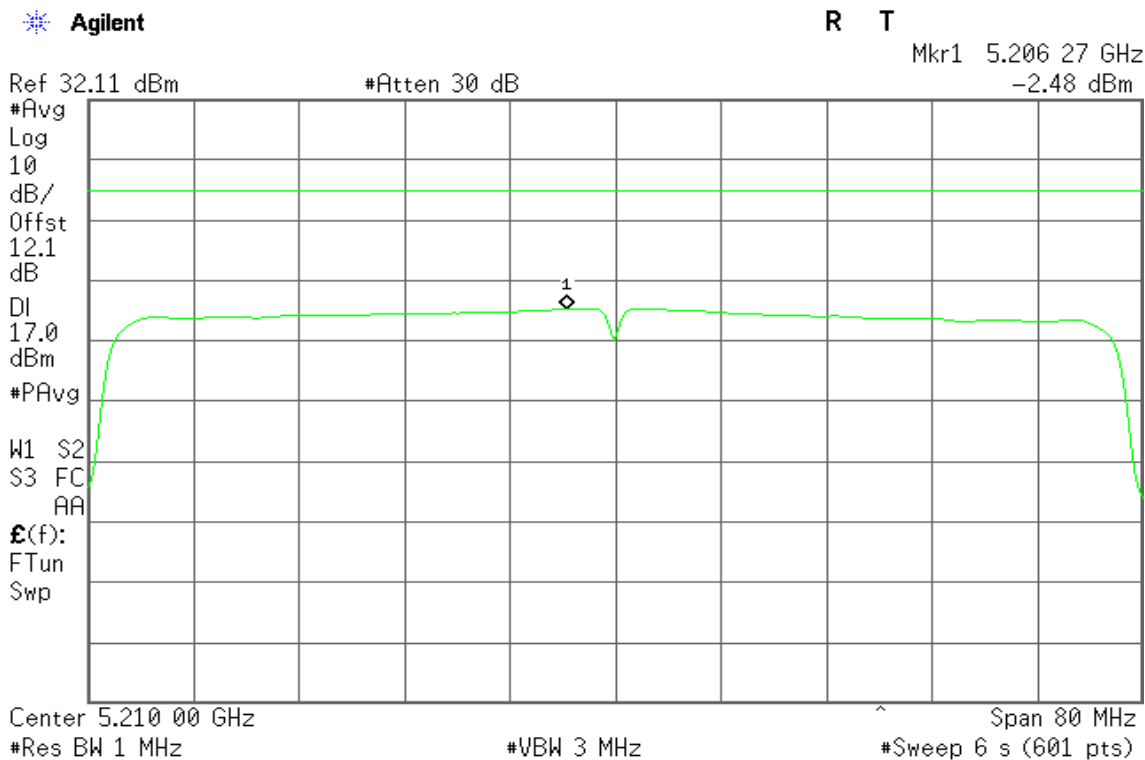

IEEE 802.11ac VHT80 Mode / 5210MHz / Chain 1

CH Mid

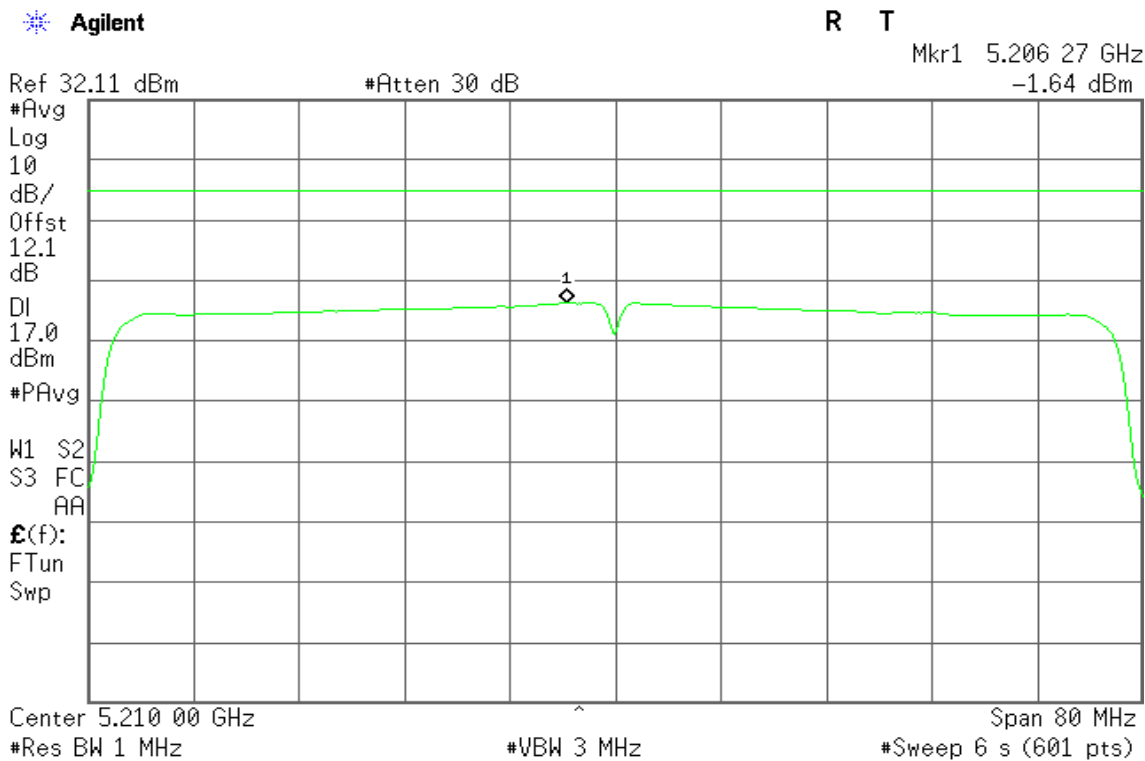

IEEE 802.11a mode / 5745 ~ 5825MHz

CH Low

Agilent

R T

Mkr1 5.744 20 GHz
 5.37 dBm

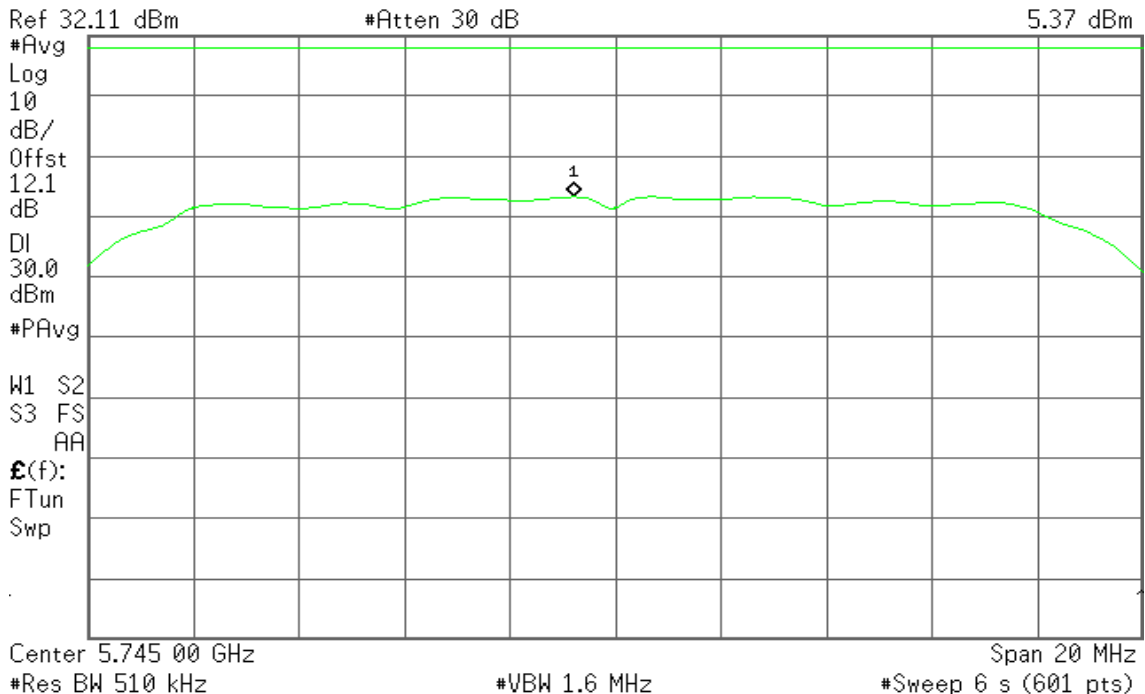

CH Mid

Agilent

R T

Mkr1 5.785 53 GHz
 6.31 dBm

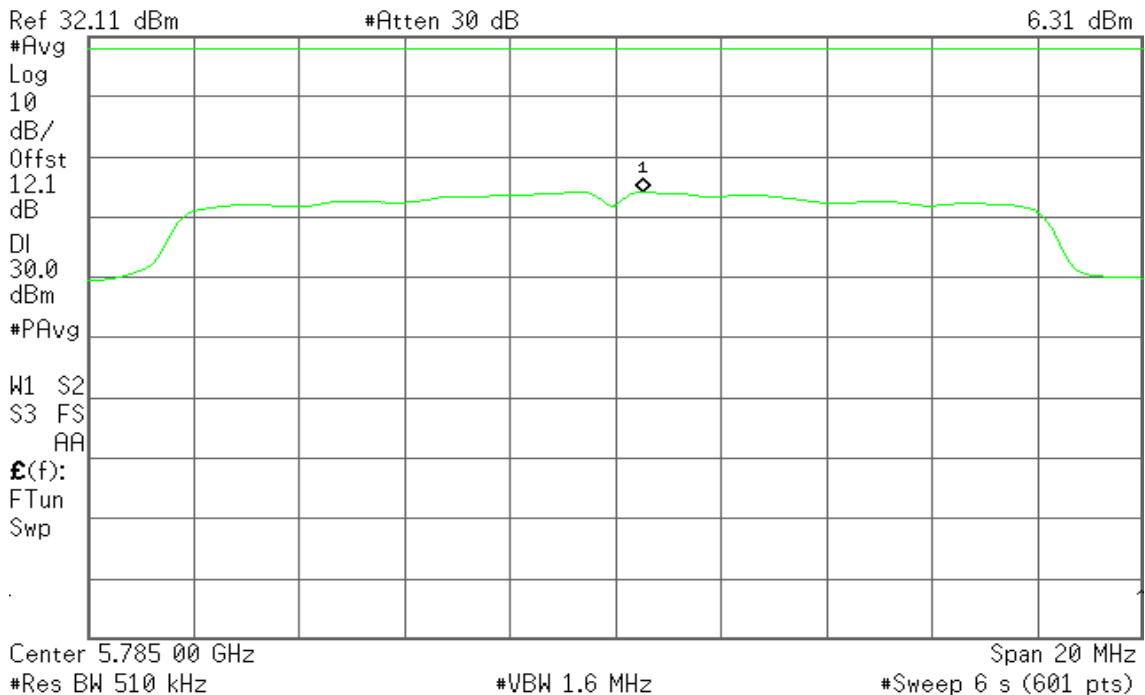

CH High

Agilent

R T

Mkr1 5.824 27 GHz
6.18 dBm

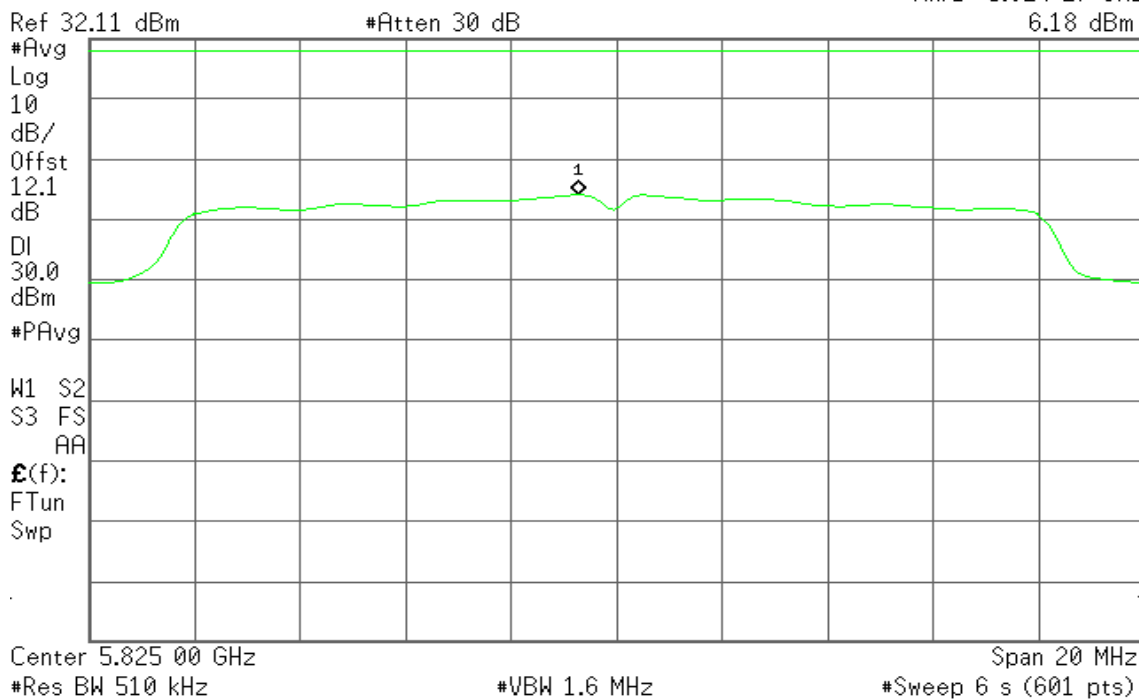

IEEE 802.11n HT 20 mode / 5745 ~ 5825MHz / Chain 0

CH Low

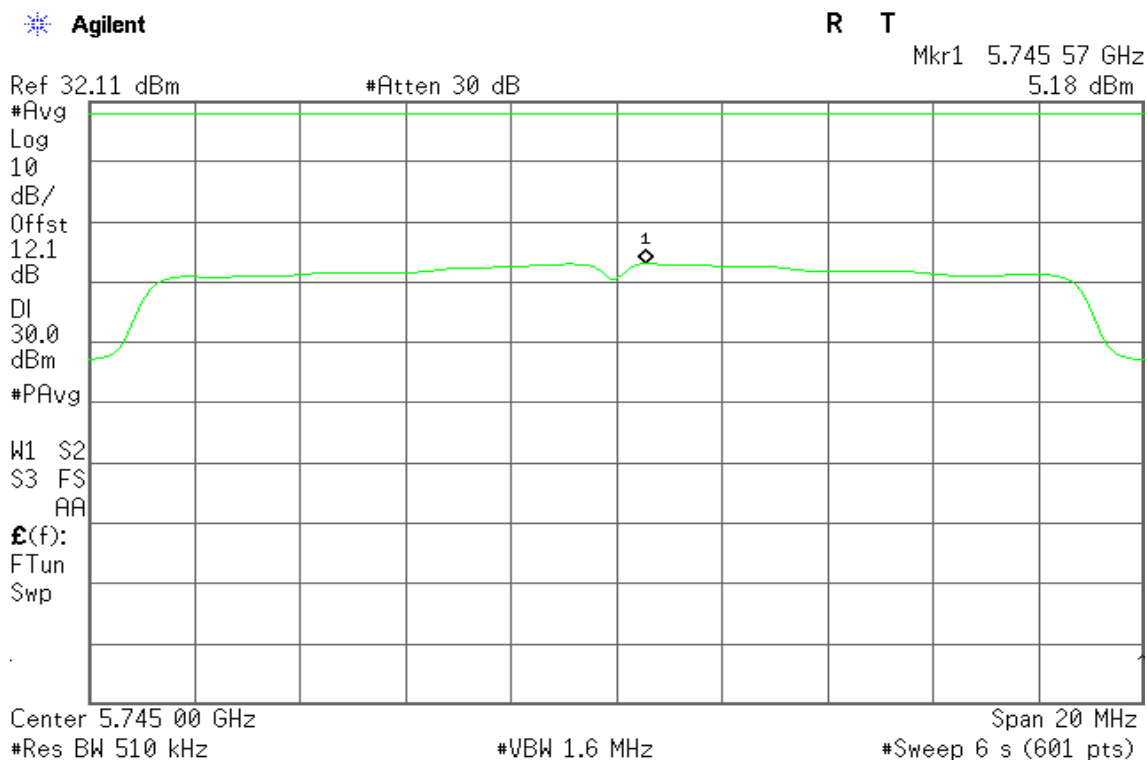

CH Mid

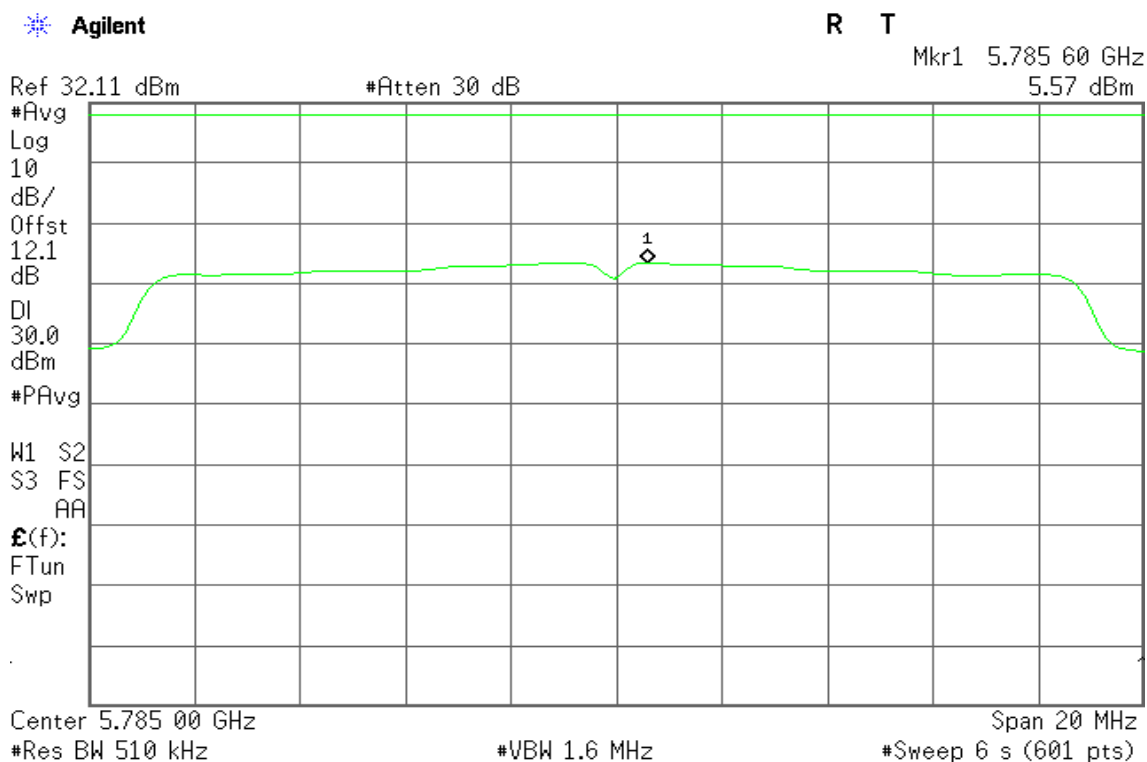

CH High

 **Agilent**

R T

Mkr1 5.825 57 GHz
 4.45 dBm

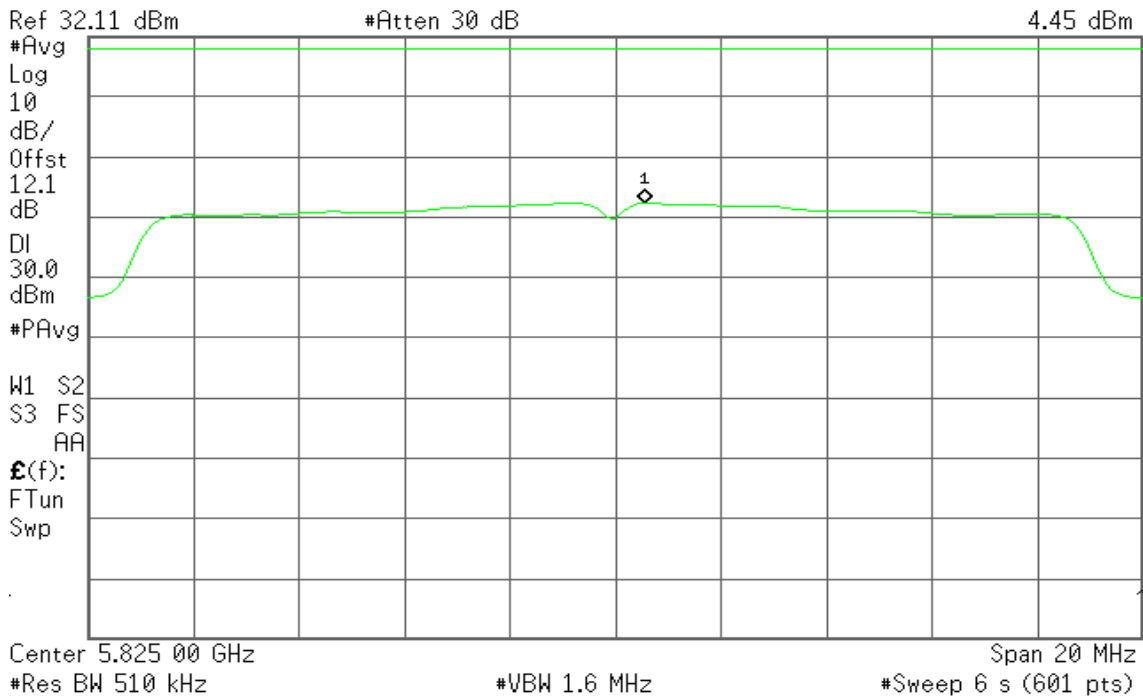

IEEE 802.11n HT 20 mode / 5745 ~ 5825MHz / Chain 1

CH Low

Agilent

R T

Mkr1 5.745 57 GHz
 7.80 dBm

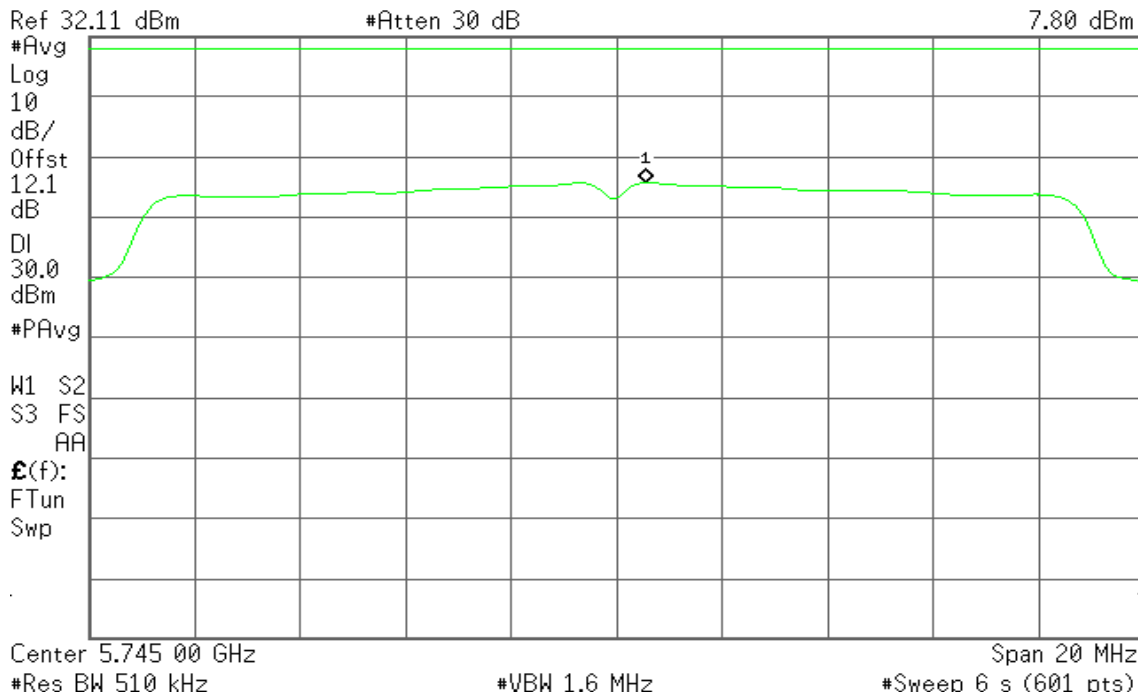

CH Mid

Agilent

R T

Mkr1 5.785 63 GHz
 8.00 dBm

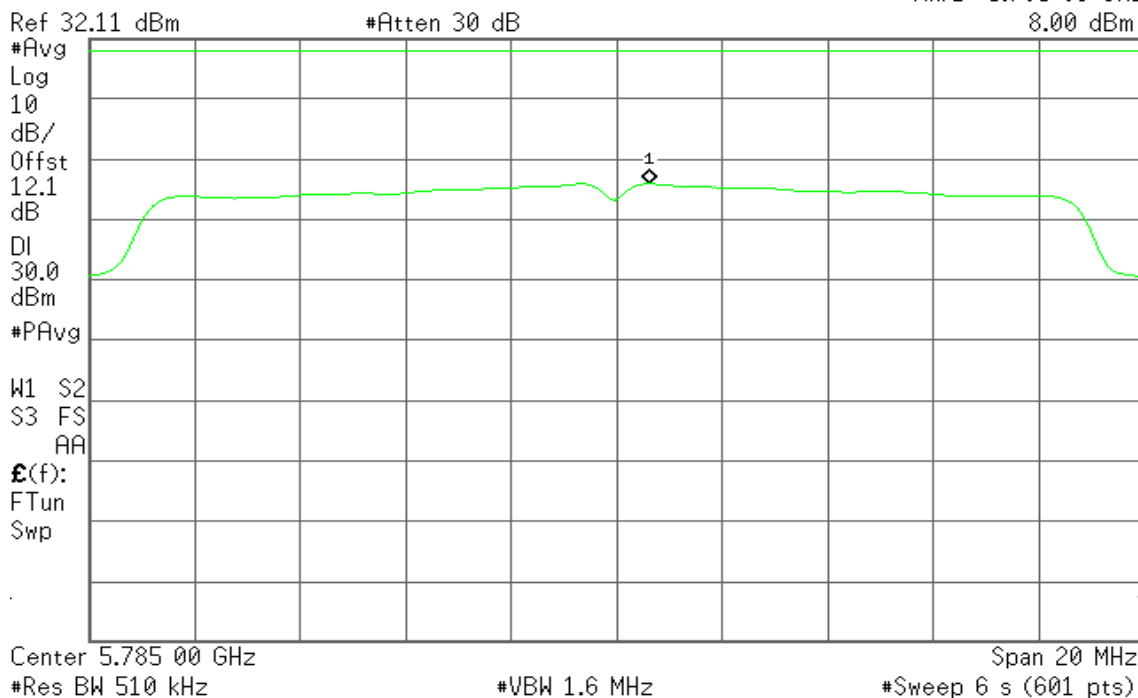

CH High

Agilent

R T

Mkr1 5.824 30 GHz
 7.56 dBm

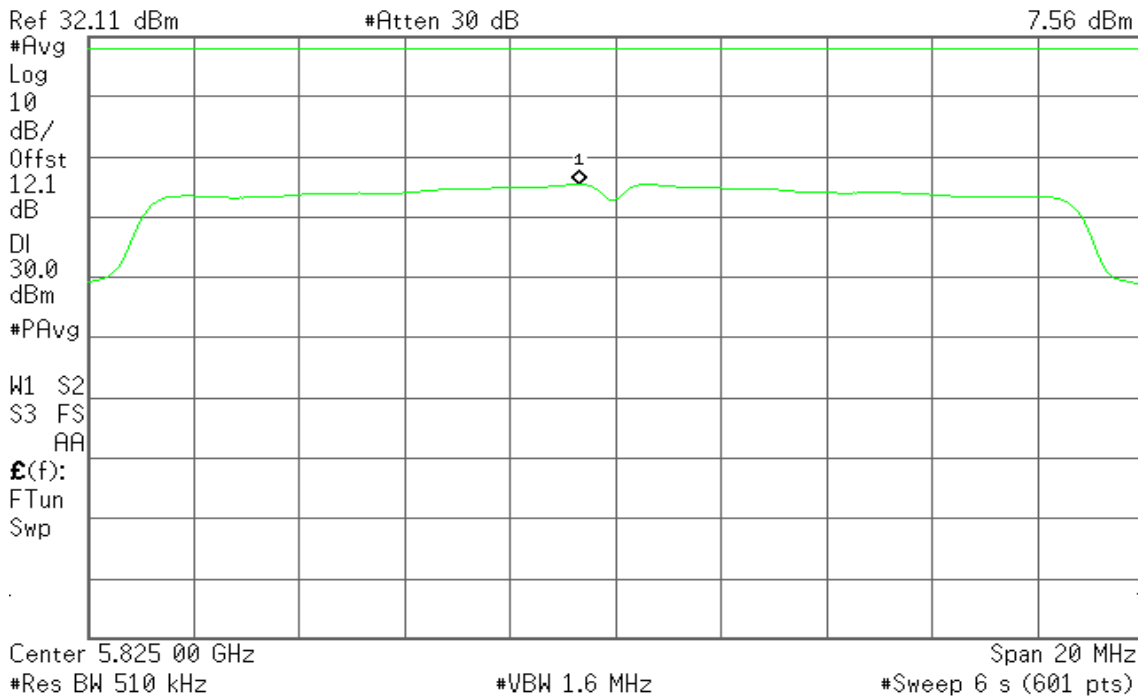

IEEE 802.11n HT 40 mode / 5755 ~ 5795MHz / Chain 0

CH Low

Agilent

R T

Mkr1 5.756 00 GHz
 2.31 dBm

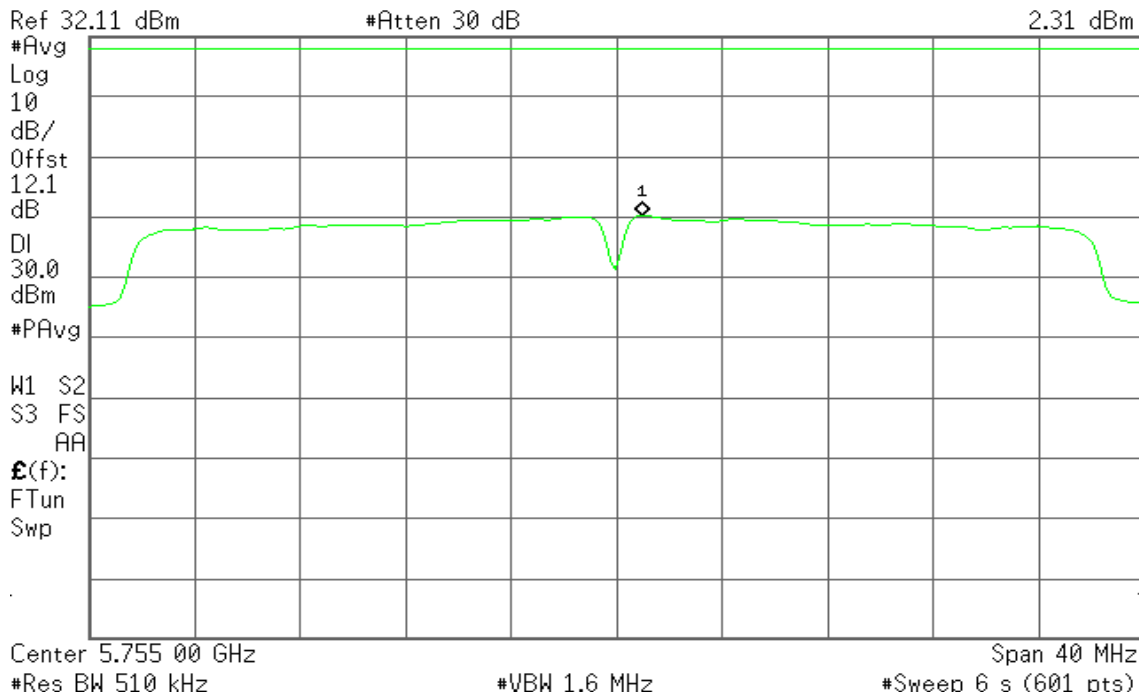

CH High

Agilent

R T

Mkr1 5.795 93 GHz
 2.74 dBm

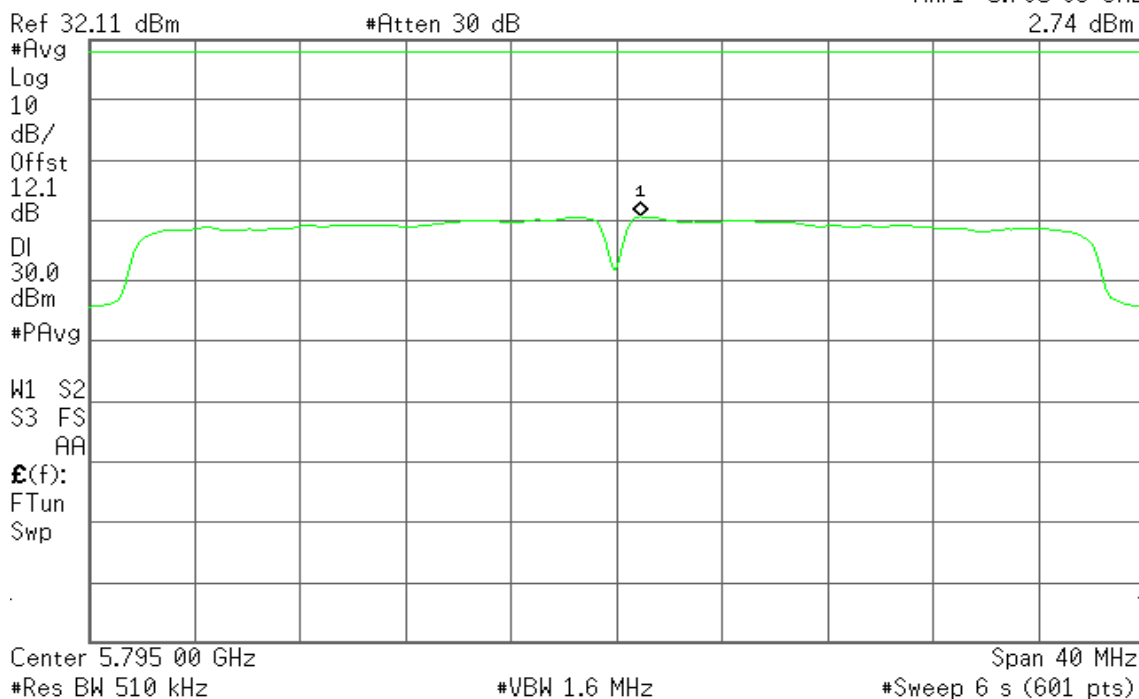

IEEE 802.11n HT 40 mode / 5755 ~ 5795MHz / Chain 1

CH Low

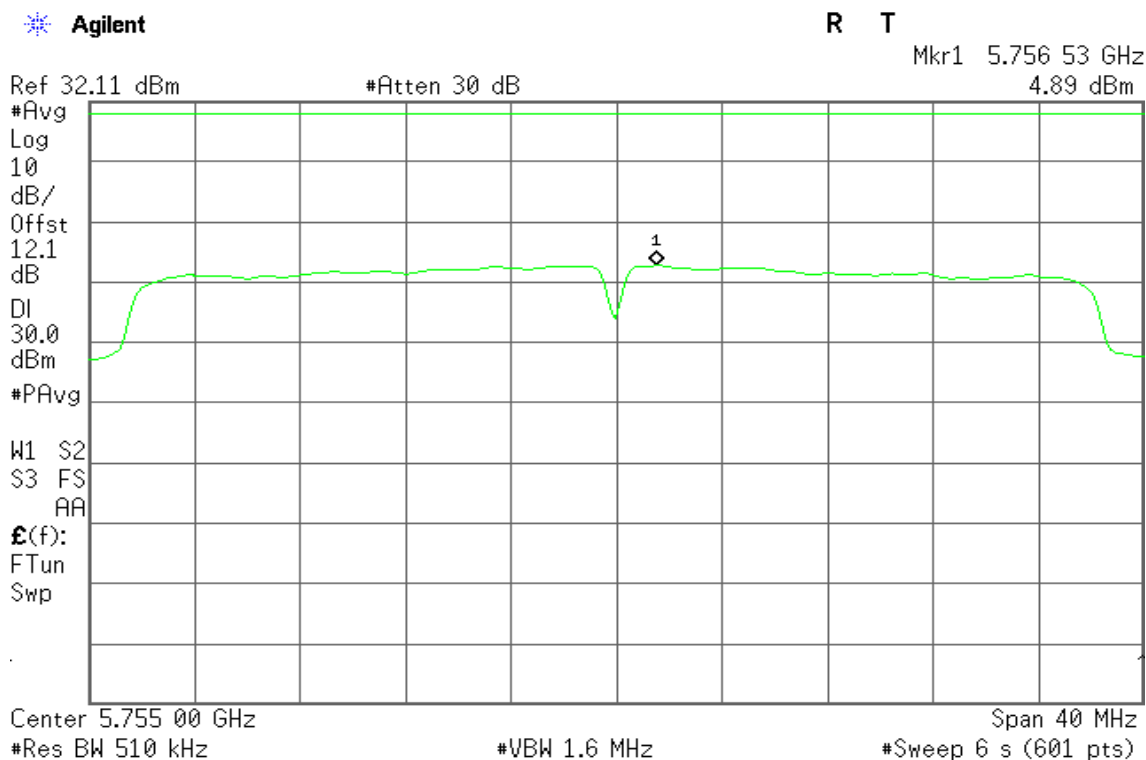

CH High

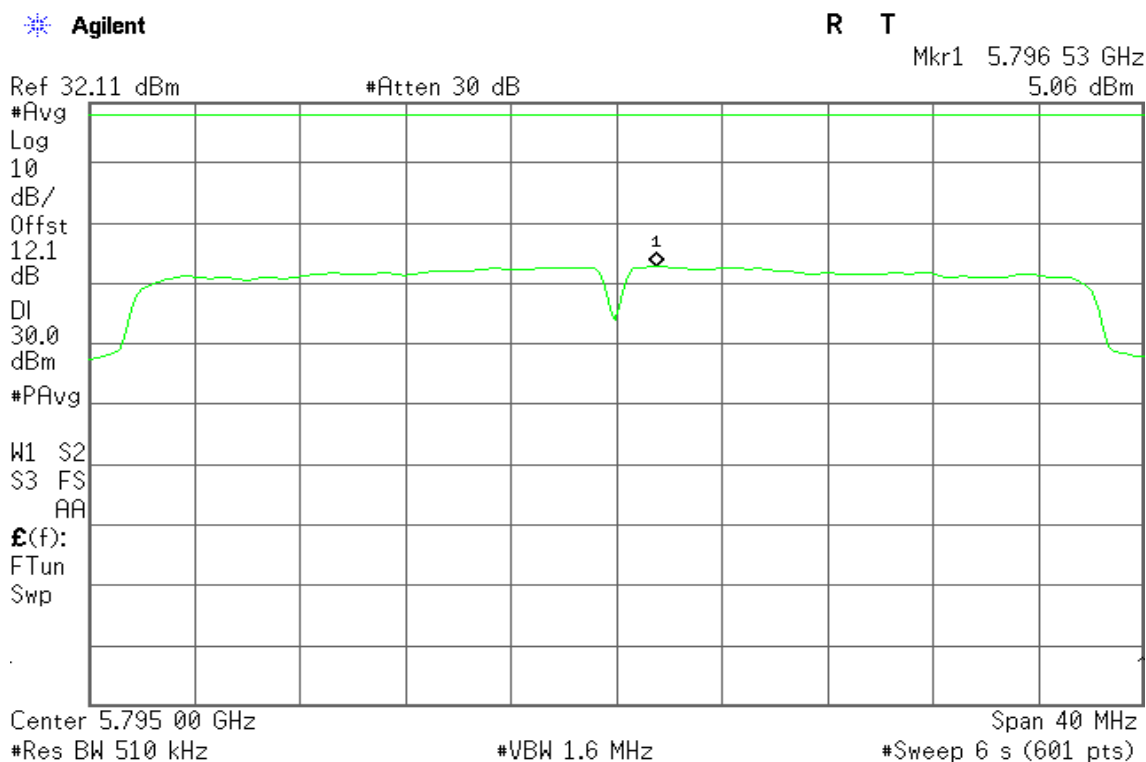

IEEE 802.11ac VHT80 Mode / 5775MHz / Chain 0

CH Mid

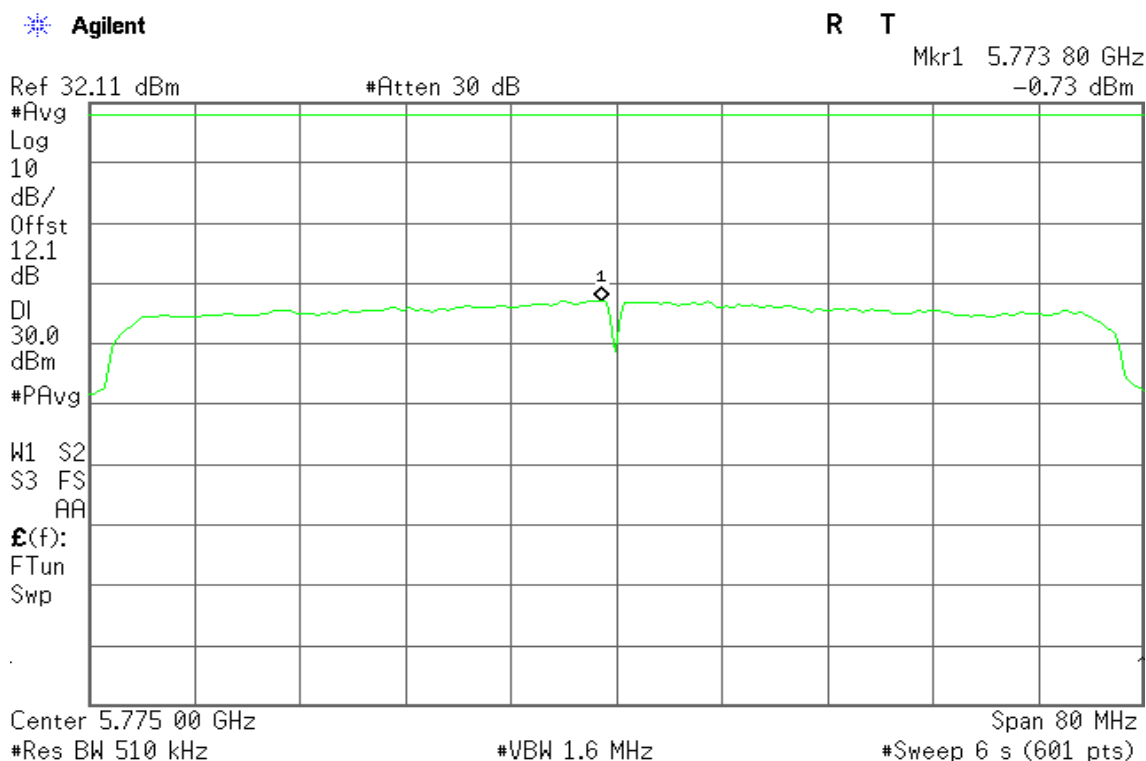

IEEE 802.11ac VHT80 Mode / 5775MHz / Chain 1

CH Mid

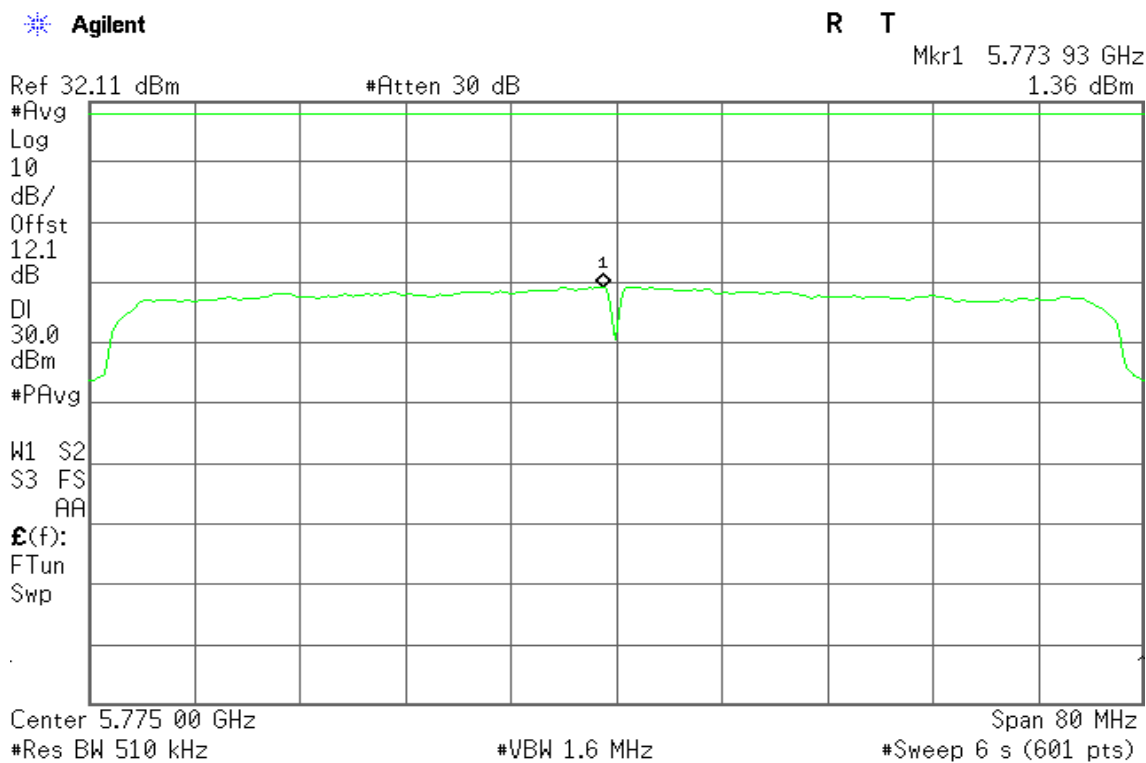

7.5 RADIATED UNDESIRABLE EMISSION

1. According to §15.209(a), except as provided elsewhere in this Subpart, the emissions from an intentional radiator shall not exceed the field strength levels specified in the following table:

Frequency (MHz)	Field Strength (µV/m)	Measurement Distance (m)
0.009 - 0.490	2400/F(kHz)	300
0.490 - 1.705	24000/F(kHz)	30
1.705 – 30.0	30	30
30-88	100	3
88-216	150	3
216-960	200	3
Above 960	500	3

Remark: Except as provided in paragraph (g), fundamental emissions from intentional radiators operating under this Section shall not be located in the frequency bands 54-72 MHz, 76-88 MHz, 174-216 MHz or 470-806 MHz. However, operation within these frequency bands is permitted under other sections of this Part, e.g., Sections 15.231 and 15.241.

2. In the emission table above, the tighter limit applies at the band edges.

Frequency (MHz)	Field Strength (µV/m at 3-meter)	Field Strength (dBµV/m at 3-meter)
0.009 - 0.490	2400/F(kHz) +80	20LOG((2400/F(kHz))+80)
0.490 - 1.705	24000/F(kHz) +40	20LOG((24000/F(kHz))+40)
1.705 – 30.0	30	69.54
30-88	100	40
88-216	150	43.5
216-960	200	46
Above 960	500	54

Test Configuration

9kHz ~ 30MHz

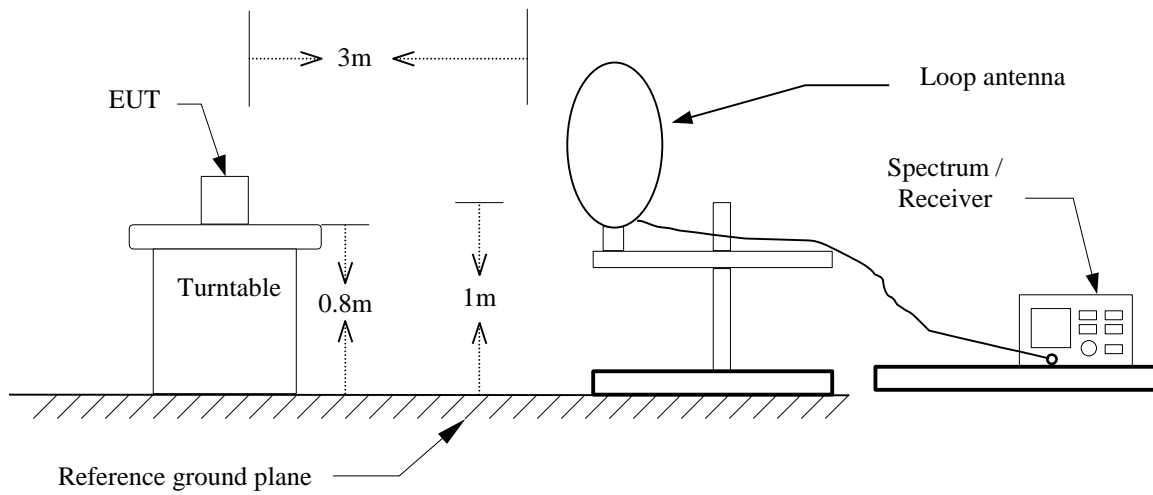

30MHz ~ 1GHz

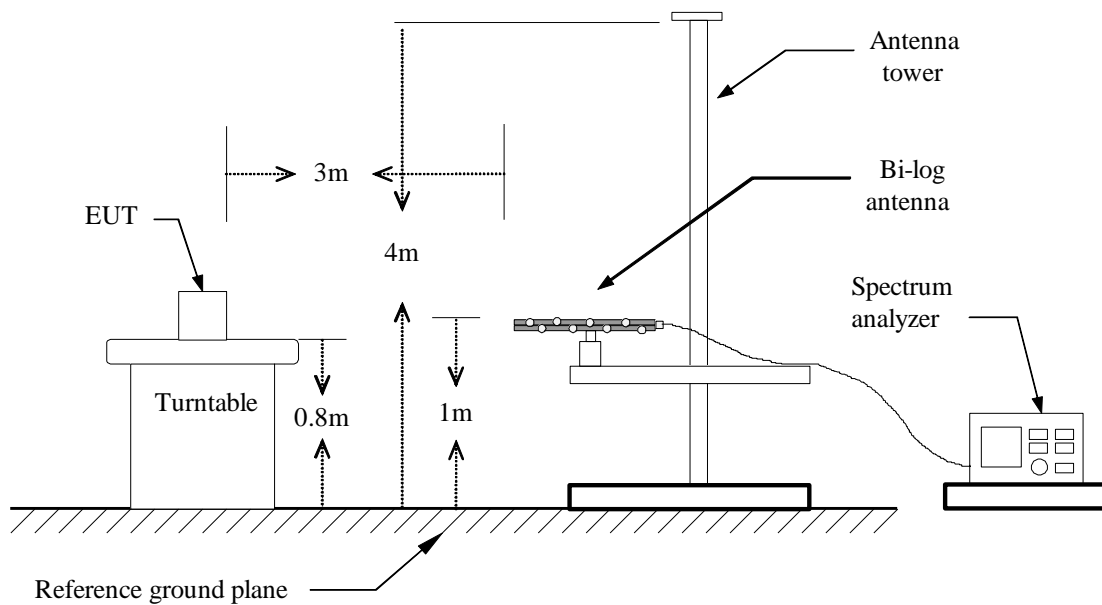

Above 1 GHz

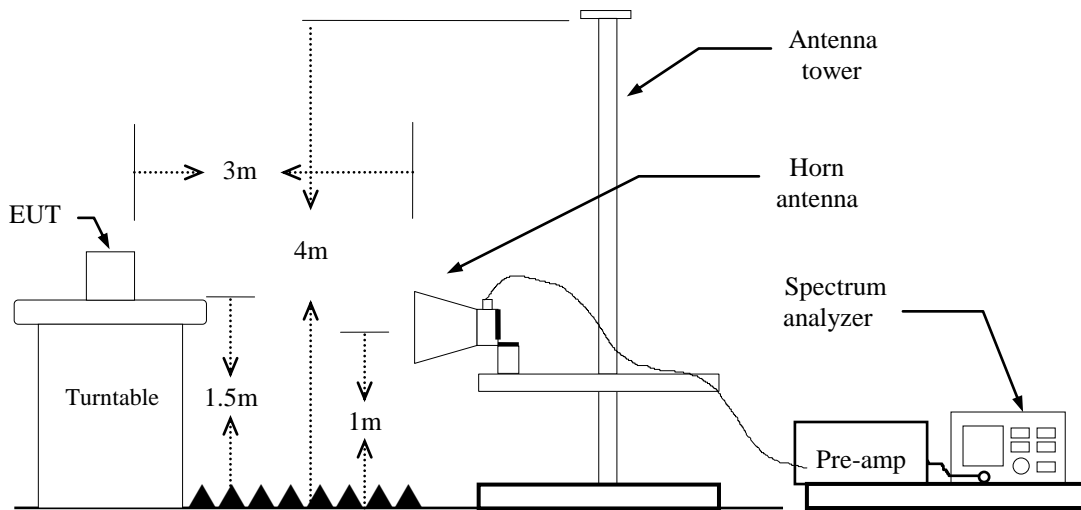

TEST PROCEDURE

1. The EUT is placed on a turntable, Above 1 GHz is 1.5m high and below 1 GHz is 0.8m high above ground plane.
2. The turntable shall be rotated for 360 degrees to determine the position of maximum emission level.
3. EUT is set 3m away from the receiving antenna, which is varied from 1m to 4m to find out the highest emissions.
4. Maximum procedure was performed on the six highest emissions to ensure EUT compliance.
5. And also, each emission was to be maximized by changing the polarization of receiving antenna both horizontal and vertical.
6. Set the spectrum analyzer in the following setting as:

Below 1GHz:

RBW=100kHz / VBW=300kHz / Sweep=AUTO

Above 1GHz:

(a) PEAK: RBW=VBW=3MHz / Sweep=AUTO

(b) AVERAGE: RBW=1MHz,
 if duty cycle \geq 98%, VBW=10Hz.

if duty cycle < 98% VBW=1/T.

IEEE 802.11b mode: \geq 98%, VBW=10Hz

IEEE 802.11g mode: \geq 98%, VBW=10Hz

IEEE 802.11n HT 20 MHz mode: \geq 98%, VBW=10Hz

IEEE 802.11n HT 40 MHz mode: \geq 98%=VBW 10Hz

7. Repeat above procedures until the measurements for all frequencies are complete.

TEST RESULTS

Below 1 GHz

Operation Mode: Normal Link

Test Date: November 6, 2015

Temperature: 27°C

Tested by: Jason Lu

Humidity: 53% RH

Polarity: Ver. / Hor.

Frequency (MHz)	Reading (dBuV)	Correction Factor (dB/m)	Result (dBuV/m)	Limit 3m (dBuV/m)	Margin (dB)	Detector Mode (PK/QP)	Ant.Pol. (H/V)
36.7900	41.93	-12.95	28.98	40.00	-11.02	Peak	V
56.1900	51.75	-21.71	30.04	40.00	-9.96	Peak	V
132.8200	43.14	-15.68	27.46	43.50	-16.04	Peak	V
229.8200	42.85	-16.74	26.11	46.00	-19.89	Peak	V
500.4500	36.53	-9.23	27.30	46.00	-18.70	Peak	V
874.8700	30.15	-3.49	26.66	46.00	-19.34	Peak	V
32.9100	30.63	-10.07	20.56	40.00	-19.44	Peak	H
132.8200	39.08	-15.68	23.40	43.50	-20.10	Peak	H
192.9600	41.43	-16.18	25.25	43.50	-18.25	Peak	H
229.8200	46.55	-16.74	29.81	46.00	-16.19	Peak	H
315.1800	38.47	-13.83	24.64	46.00	-21.36	Peak	H
874.8700	31.54	-3.49	28.05	46.00	-17.95	Peak	H

Remark:

1. Measuring frequencies from 30 MHz to the 1GHz.
2. Radiated emissions measured in frequency range from 30 MHz to 1000MHz were made with an instrument using peak/quasi-peak detector mode.
3. Quasi-peak test would be performed if the peak result were greater than the quasi-peak limit or as required by the applicant.
4. Measurements above show only up to 6 maximum emissions noted, or would be lesser, with " N/A " remark, if no specific emissions from the EUT are recorded (ie: margin>20dB from the applicable limit) and considered that's already beyond the background noise floor.
5. Margin (dB) = Remark result (dBuV/m) – Quasi-peak limit (dBuV/m).

Above 1 GHz

Operation Mode: Tx / IEEE 802.11a mode / 5180 ~ 5240MHz / CH Low
Temperature: 27°C
Humidity: 53% RH

Test Date: March 11, 2015
Tested by: Jason Lu
Polarity: Ver. / Hor.

Frequency (MHz)	Reading (dBuV)	Correction (dB/m)	Result (dBuV/m)	Limit (dBuV/m)	Margin (dB)	Remark	Ant.Pol. (H/V)
1952.000	51.01	-5.13	45.88	74.00	-28.12	peak	V
10350.000	34.77	16.48	51.25	74.00	-22.75	peak	V
15550.000	43.88	19.05	62.93	74.00	-11.07	peak	V
15550.000	32.59	19.05	51.64	54.00	-2.36	AVG	V
N/A							
1497.000	53.43	-7.54	45.89	74.00	-28.11	peak	H
N/A							

Remark:

1. Measuring frequencies from 1 GHz to the 10th harmonic of highest fundamental frequency.
2. Radiated emissions measured in frequency above 1000MHz were made with an instrument using peak/average detector mode.
3. Average test would be performed if the peak result were greater than the average limit.
4. Data of measurement within this frequency range shown “ --- ” in the table above means the reading of emissions are attenuated more than 20dB below the permissible limits or the field strength is too small to be measured.
5. Measurements above show only up to 6 maximum emissions noted, or would be lesser, with “ N/A ” remark, if no specific emissions from the EUT are recorded (ie: margin>20dB from the applicable limit) and considered that's already beyond the background noise floor.
6. Margin (dB) = Remark result (dBuV/m) – Average limit (dBuV/m).

Operation Mode: Tx / IEEE 802.11a mode /
5180 ~ 5240MHz / CH Mid
Temperature: 27°C
Humidity: 53% RH

Test Date: March 11, 2015
Tested by: Jason Lu
Polarity: Ver. / Hor.

Frequency (MHz)	Reading (dBuV)	Correction (dB/m)	Result (dBuV/m)	Limit (dBuV/m)	Margin (dB)	Remark	Ant.Pol. (H/V)
2400.000	51.61	-3.69	47.92	74.00	-26.08	peak	V
10440.000	34.95	16.89	51.84	74.00	-22.16	peak	V
15660.000	46.44	19.14	65.58	74.00	-8.42	peak	V
15660.000	31.42	19.14	50.56	54.00	-3.44	AVG	V
N/A							
2799.000	49.56	-2.52	47.04	74.00	-26.96	peak	H
15660.000	35.93	19.14	55.07	74.00	-18.93	peak	H
15660.000	25.78	19.14	44.92	54.00	-9.08	AVG	H
N/A							

Remark:

1. Measuring frequencies from 1 GHz to the 10th harmonic of highest fundamental frequency.
2. Radiated emissions measured in frequency above 1000MHz were made with an instrument using peak/average detector mode.
3. Average test would be performed if the peak result were greater than the average limit.
4. Data of measurement within this frequency range shown " --- " in the table above means the reading of emissions are attenuated more than 20dB below the permissible limits or the field strength is too small to be measured.
5. Measurements above show only up to 6 maximum emissions noted, or would be lesser, with " N/A " remark, if no specific emissions from the EUT are recorded (ie: margin>20dB from the applicable limit) and considered that's already beyond the background noise floor.
6. Margin (dB) = Remark result (dBuV/m) – Average limit (dBuV/m).

Operation Mode: Tx / IEEE 802.11a mode /
5180 ~ 5240MHz / CH High
Temperature: 27°C
Humidity: 53% RH

Test Date: March 11, 2015
Tested by: Jason Lu
Polarity: Ver. / Hor.

Frequency (MHz)	Reading (dBuV)	Correction (dB/m)	Result (dBuV/m)	Limit (dBuV/m)	Margin (dB)	Remark	Ant.Pol. (H/V)
2498.000	48.97	-3.14	45.83	74.00	-28.17	peak	V
10480.000	34.92	17.07	51.99	74.00	-22.01	peak	V
15720.000	42.33	19.19	61.52	74.00	-12.48	peak	V
15720.000	27.66	19.19	46.85	54.00	-7.15	AVG	
N/A							
2687.000	50.50	-2.74	47.76	74.00	-26.24	peak	H
N/A							

Remark:

1. Measuring frequencies from 1 GHz to the 10th harmonic of highest fundamental frequency.
2. Radiated emissions measured in frequency above 1000MHz were made with an instrument using peak/average detector mode.
3. Average test would be performed if the peak result were greater than the average limit.
4. Data of measurement within this frequency range shown " --- " in the table above means the reading of emissions are attenuated more than 20dB below the permissible limits or the field strength is too small to be measured.
5. Measurements above show only up to 6 maximum emissions noted, or would be lesser, with " N/A " remark, if no specific emissions from the EUT are recorded (ie: margin>20dB from the applicable limit) and considered that's already beyond the background noise floor.
6. Margin (dB) = Remark result (dBuV/m) – Average limit (dBuV/m).

Operation Mode: Tx / IEEE 802.11n HT 20 mode /
5180 ~ 5240MHz / CH Low
Temperature: 27°C
Humidity: 53% RH

Test Date: March 11, 2015
Tested by: Jason Lu
Polarity: Ver. / Hor.

Frequency (MHz)	Reading (dBuV)	Correction (dB/m)	Result (dBuV/m)	Limit (dBuV/m)	Margin (dB)	Remark	Ant.Pol. (H/V)
2547.000	49.46	-3.03	46.43	74.00	-27.57	peak	V
15540.000	40.14	19.04	59.18	74.00	-14.82	peak	V
15540.000	30.69	19.04	49.73	54.00	-4.27	AVG	V
N/A							
2680.000	50.04	-2.76	47.28	74.00	-26.72	peak	H
N/A							

Remark:

1. Measuring frequencies from 1 GHz to the 10th harmonic of highest fundamental frequency.
2. Radiated emissions measured in frequency above 1000MHz were made with an instrument using peak/average detector mode.
3. Average test would be performed if the peak result were greater than the average limit.
4. Data of measurement within this frequency range shown " --- " in the table above means the reading of emissions are attenuated more than 20dB below the permissible limits or the field strength is too small to be measured.
5. Measurements above show only up to 6 maximum emissions noted, or would be lesser, with " N/A " remark, if no specific emissions from the EUT are recorded (ie: margin>20dB from the applicable limit) and considered that's already beyond the background noise floor.
6. Margin (dB) = Remark result (dBuV/m) – Average limit (dBuV/m).

Operation Mode: Tx / IEEE 802.11n HT 20 mode / 5180 ~ 5240MHz / CH Mid
Temperature: 27°C
Humidity: 53% RH

Test Date: March 11, 2015
Tested by: Jason Lu
Polarity: Ver. / Hor.

Frequency (MHz)	Reading (dBuV)	Correction (dB/m)	Result (dBuV/m)	Limit (dBuV/m)	Margin (dB)	Remark	Ant.Pol. (H/V)
2393.000	52.52	-3.75	48.77	74.00	-25.23	peak	V
10440.000	34.30	16.89	51.19	74.00	-22.81	peak	V
15660.000	41.85	19.14	60.99	74.00	-13.01	peak	V
15660.000	33.32	19.14	52.46	74.00	-21.54	peak	V
N/A							
2428.000	49.56	-3.58	45.98	74.00	-28.02	peak	H
N/A							

Remark:

1. Measuring frequencies from 1 GHz to the 10th harmonic of highest fundamental frequency.
2. Radiated emissions measured in frequency above 1000MHz were made with an instrument using peak/average detector mode.
3. Average test would be performed if the peak result were greater than the average limit.
4. Data of measurement within this frequency range shown " --- " in the table above means the reading of emissions are attenuated more than 20dB below the permissible limits or the field strength is too small to be measured.
5. Measurements above show only up to 6 maximum emissions noted, or would be lesser, with " N/A " remark, if no specific emissions from the EUT are recorded (ie: margin>20dB from the applicable limit) and considered that's already beyond the background noise floor.
6. Margin (dB) = Remark result (dBuV/m) – Average limit (dBuV/m).

Operation Mode: Tx / IEEE 802.11n HT 20 mode / 5180 ~ 5240MHz / CH High
Temperature: 27°C
Humidity: 53% RH

Test Date: March 11, 2015
Tested by: Jason Lu
Polarity: Ver. / Hor.

Frequency (MHz)	Reading (dBuV)	Correction (dB/m)	Result (dBuV/m)	Limit (dBuV/m)	Margin (dB)	Remark	Ant.Pol. (H/V)
2379.000	50.22	-3.87	46.35	74.00	-27.65	peak	V
10480.000	34.10	17.07	51.17	74.00	-22.83	peak	V
15710.000	41.18	19.19	60.37	74.00	-13.63	peak	V
15710.000	32.17	19.19	51.36	54.00	-2.64	AVG	V
N/A							
2519.000	51.14	-3.08	48.06	74.00	-25.94	peak	H
N/A							

Remark:

1. Measuring frequencies from 1 GHz to the 10th harmonic of highest fundamental frequency.
2. Radiated emissions measured in frequency above 1000MHz were made with an instrument using peak/average detector mode.
3. Average test would be performed if the peak result were greater than the average limit.
4. Data of measurement within this frequency range shown " --- " in the table above means the reading of emissions are attenuated more than 20dB below the permissible limits or the field strength is too small to be measured.
5. Measurements above show only up to 6 maximum emissions noted, or would be lesser, with " N/A " remark, if no specific emissions from the EUT are recorded (ie: margin>20dB from the applicable limit) and considered that's already beyond the background noise floor.
6. Margin (dB) = Remark result (dBuV/m) – Average limit (dBuV/m).

Operation Mode: Tx / IEEE 802.11n HT 40 mode / 5190 ~ 5230MHz / CH Low
Temperature: 27°C
Humidity: 53% RH

Test Date: March 11, 2015
Tested by: Jason Lu
Polarity: Ver. / Hor.

Frequency (MHz)	Reading (dBuV)	Correction (dB/m)	Result (dBuV/m)	Limit (dBuV/m)	Margin (dB)	Remark	Ant.Pol. (H/V)
1959.000	52.89	-5.10	47.79	74.00	-26.21	peak	V
N/A							
N/A							
1959.000	52.01	-5.10	46.91	74.00	-27.09	peak	H
N/A							

Remark:

1. Measuring frequencies from 1 GHz to the 10th harmonic of highest fundamental frequency.
2. Radiated emissions measured in frequency above 1000MHz were made with an instrument using peak/average detector mode.
3. Average test would be performed if the peak result were greater than the average limit.
4. Data of measurement within this frequency range shown " --- " in the table above means the reading of emissions are attenuated more than 20dB below the permissible limits or the field strength is too small to be measured.
5. Measurements above show only up to 6 maximum emissions noted, or would be lesser, with " N/A " remark, if no specific emissions from the EUT are recorded (ie: margin>20dB from the applicable limit) and considered that's already beyond the background noise floor.
6. Margin (dB) = Remark result (dBuV/m) – Average limit (dBuV/m).

Operation Mode: Tx / IEEE 802.11n HT 40 mode / 5190 ~ 5230MHz / CH High
Temperature: 27°C
Humidity: 53% RH

Test Date: March 11, 2015
Tested by: Jason Lu
Polarity: Ver. / Hor.

Frequency (MHz)	Reading (dBuV)	Correction (dB/m)	Result (dBuV/m)	Limit (dBuV/m)	Margin (dB)	Remark	Ant.Pol. (H/V)
2379.000	49.89	-3.87	46.02	74.00	-27.98	peak	V
10460.000	34.85	16.98	51.83	74.00	-22.17	peak	V
15690.000	41.09	19.17	60.26	74.00	-13.74	peak	V
15690.000	30.08	19.17	49.25	54.00	-4.75	AVG	V
N/A							
2603.000	49.67	-2.91	46.76	74.00	-27.24	peak	H
N/A							

Remark:

1. Measuring frequencies from 1 GHz to the 10th harmonic of highest fundamental frequency.
2. Radiated emissions measured in frequency above 1000MHz were made with an instrument using peak/average detector mode.
3. Average test would be performed if the peak result were greater than the average limit.
4. Data of measurement within this frequency range shown " --- " in the table above means the reading of emissions are attenuated more than 20dB below the permissible limits or the field strength is too small to be measured.
5. Measurements above show only up to 6 maximum emissions noted, or would be lesser, with " N/A " remark, if no specific emissions from the EUT are recorded (ie: margin>20dB from the applicable limit) and considered that's already beyond the background noise floor.
6. Margin (dB) = Remark result (dBuV/m) – Average limit (dBuV/m).

Operation Mode: Tx / IEEE 802.11ac VHT80 Mode / 5210MHz / CH Mid
Temperature: 27°C
Humidity: 53% RH

Test Date: March 11, 2015
Tested by: Jason Lu
Polarity: Ver. / Hor.

Frequency (MHz)	Reading (dBuV)	Correction (dB/m)	Result (dBuV/m)	Limit (dBuV/m)	Margin (dB)	Remark	Ant.Pol. (H/V)
2393.000	50.45	-3.75	46.70	74.00	-27.30	peak	V
N/A							
2540.000	49.63	-3.04	46.59	74.00	-27.41	peak	H
N/A							

Remark:

1. Measuring frequencies from 1 GHz to the 10th harmonic of highest fundamental frequency.
2. Radiated emissions measured in frequency above 1000MHz were made with an instrument using peak/average detector mode.
3. Average test would be performed if the peak result were greater than the average limit.
4. Data of measurement within this frequency range shown " --- " in the table above means the reading of emissions are attenuated more than 20dB below the permissible limits or the field strength is too small to be measured.
5. Measurements above show only up to 6 maximum emissions noted, or would be lesser, with " N/A " remark, if no specific emissions from the EUT are recorded (ie: margin>20dB from the applicable limit) and considered that's already beyond the background noise floor.
6. Margin (dB) = Remark result (dBuV/m) – Average limit (dBuV/m).

Operation Mode: Tx / IEEE 802.11a mode / 5745 ~ 5825MHz / CH Low
Temperature: 27°C
Humidity: 53% RH

Test Date: March 11, 2015
Tested by: Jason Lu
Polarity: Ver. / Hor.

Frequency (MHz)	Reading (dBuV)	Correction (dB/m)	Result (dBuV/m)	Limit (dBuV/m)	Margin (dB)	Remark	Ant.Pol. (H/V)
2533.000	49.87	-3.05	46.82	74.00	-27.18	peak	V
11500.000	41.15	16.78	57.93	74.00	-16.07	peak	V
11500.000	34.80	16.78	51.58	54.00	-2.42	AVG	V
17240.000	39.79	25.30	65.09	74.00	-8.91	peak	V
17240.000	28.67	25.30	53.97	54.00	-0.03	AVG	V
N/A							
2540.000	51.12	-3.04	48.08	74.00	-25.92	peak	H
N/A							

Remark:

1. Measuring frequencies from 1 GHz to the 10th harmonic of highest fundamental frequency.
2. Radiated emissions measured in frequency above 1000MHz were made with an instrument using peak/average detector mode.
3. Average test would be performed if the peak result were greater than the average limit.
4. Data of measurement within this frequency range shown " --- " in the table above means the reading of emissions are attenuated more than 20dB below the permissible limits or the field strength is too small to be measured.
5. Measurements above show only up to 6 maximum emissions noted, or would be lesser, with " N/A " remark, if no specific emissions from the EUT are recorded (ie: margin>20dB from the applicable limit) and considered that's already beyond the background noise floor.
6. Margin (dB) = Remark result (dBuV/m) – Average limit (dBuV/m).

Operation Mode: Tx / IEEE 802.11a mode / 5745 ~ 5825MHz / CH Mid
Temperature: 27°C
Humidity: 53% RH

Test Date: March 11, 2015
Tested by: Jason Lu
Polarity: Ver. / Hor.

Frequency (MHz)	Reading (dBuV)	Correction (dB/m)	Result (dBuV/m)	Limit (dBuV/m)	Margin (dB)	Remark	Ant.Pol. (H/V)
2533.000	50.17	-3.05	47.12	74.00	-26.88	peak	V
11570.000	40.08	16.84	56.92	74.00	-17.08	peak	V
11570.000	32.60	16.84	49.44	54.00	-4.56	AVG	V
17350.000	38.15	25.73	63.88	74.00	-10.12	peak	V
17350.000	26.45	25.73	52.18	54.00	-1.82	AVG	V
N/A							
2372.000	50.36	-3.92	46.44	74.00	-27.56	peak	H
N/A							

Remark:

1. Measuring frequencies from 1 GHz to the 10th harmonic of highest fundamental frequency.
2. Radiated emissions measured in frequency above 1000MHz were made with an instrument using peak/average detector mode.
3. Average test would be performed if the peak result were greater than the average limit.
4. Data of measurement within this frequency range shown " --- " in the table above means the reading of emissions are attenuated more than 20dB below the permissible limits or the field strength is too small to be measured.
5. Measurements above show only up to 6 maximum emissions noted, or would be lesser, with " N/A " remark, if no specific emissions from the EUT are recorded (ie: margin>20dB from the applicable limit) and considered that's already beyond the background noise floor.
6. Margin (dB) = Remark result (dBuV/m) – Average limit (dBuV/m).

Operation Mode: Tx / IEEE 802.11a mode / 5745 ~ 5825MHz / CH High
Temperature: 27°C
Humidity: 53% RH

Test Date: March 11, 2015
Tested by: Jason Lu
Polarity: Ver. / Hor.

Frequency (MHz)	Reading (dBuV)	Correction (dB/m)	Result (dBuV/m)	Limit (dBuV/m)	Margin (dB)	Remark	Ant.Pol. (H/V)
3261.000	53.04	-1.48	51.56	74.00	-22.44	peak	V
11650.000	37.90	16.91	54.81	74.00	-19.19	peak	V
11650.000	31.60	16.91	48.51	54.00	-5.49	AVG	V
17470.000	36.78	26.20	62.98	74.00	-11.02	peak	V
17470.000	26.83	26.20	53.03	54.00	-0.97	AVG	V
N/A							
1952.000	52.14	-5.13	47.01	74.00	-26.99	peak	H
N/A							

Remark:

1. Measuring frequencies from 1 GHz to the 10th harmonic of highest fundamental frequency.
2. Radiated emissions measured in frequency above 1000MHz were made with an instrument using peak/average detector mode.
3. Average test would be performed if the peak result were greater than the average limit.
4. Data of measurement within this frequency range shown " --- " in the table above means the reading of emissions are attenuated more than 20dB below the permissible limits or the field strength is too small to be measured.
5. Measurements above show only up to 6 maximum emissions noted, or would be lesser, with " N/A " remark, if no specific emissions from the EUT are recorded (ie: margin>20dB from the applicable limit) and considered that's already beyond the background noise floor.
6. Margin (dB) = Remark result (dBuV/m) – Average limit (dBuV/m).

Operation Mode: Tx / IEEE 802.11n HT 20 mode / 5745 ~ 5825MHz / CH Low
Temperature: 27°C
Humidity: 53% RH

Test Date: March 11, 2015
Tested by: Jason Lu
Polarity: Ver. / Hor.

Frequency (MHz)	Reading (dBuV)	Correction (dB/m)	Result (dBuV/m)	Limit (dBuV/m)	Margin (dB)	Remark	Ant.Pol. (H/V)
2393.000	52.52	-3.75	48.77	74.00	-25.23	peak	V
11500.000	40.29	16.78	57.07	74.00	-16.93	peak	V
11500.000	31.85	16.78	48.63	54.00	-5.37	AVG	V
17230.000	38.51	25.26	63.77	74.00	-10.23	peak	V
17230.000	27.53	25.26	52.79	54.00	-1.21	AVG	V
N/A							
2463.000	50.84	-3.37	47.47	74.00	-26.53	peak	H
N/A							

Remark:

1. Measuring frequencies from 1 GHz to the 10th harmonic of highest fundamental frequency.
2. Radiated emissions measured in frequency above 1000MHz were made with an instrument using peak/average detector mode.
3. Average test would be performed if the peak result were greater than the average limit.
4. Data of measurement within this frequency range shown " --- " in the table above means the reading of emissions are attenuated more than 20dB below the permissible limits or the field strength is too small to be measured.
5. Measurements above show only up to 6 maximum emissions noted, or would be lesser, with " N/A " remark, if no specific emissions from the EUT are recorded (ie: margin>20dB from the applicable limit) and considered that's already beyond the background noise floor.
6. Margin (dB) = Remark result (dBuV/m) – Average limit (dBuV/m).

Operation Mode: Tx / IEEE 802.11n HT 20 mode / 5745 ~ 5825MHz / CH Mid
Temperature: 27°C
Humidity: 53% RH

Test Date: March 11, 2015
Tested by: Jason Lu
Polarity: Ver. / Hor.

Frequency (MHz)	Reading (dBuV)	Correction (dB/m)	Result (dBuV/m)	Limit (dBuV/m)	Margin (dB)	Remark	Ant.Pol. (H/V)
2393.000	53.78	-3.75	50.03	74.00	-23.97	peak	V
11570.000	39.63	16.84	56.47	74.00	-17.53	peak	V
11570.000	32.61	16.84	49.45	54.00	-4.55	AVG	V
17350.000	37.40	25.73	63.13	74.00	-10.87	peak	V
17350.000	26.89	25.73	52.62	54.00	-1.38	AVG	V
N/A							
2694.000	52.75	-2.73	50.02	74.00	-23.98	peak	H
N/A							

Remark:

1. Measuring frequencies from 1 GHz to the 10th harmonic of highest fundamental frequency.
2. Radiated emissions measured in frequency above 1000MHz were made with an instrument using peak/average detector mode.
3. Average test would be performed if the peak result were greater than the average limit.
4. Data of measurement within this frequency range shown " --- " in the table above means the reading of emissions are attenuated more than 20dB below the permissible limits or the field strength is too small to be measured.
5. Measurements above show only up to 6 maximum emissions noted, or would be lesser, with " N/A " remark, if no specific emissions from the EUT are recorded (ie: margin>20dB from the applicable limit) and considered that's already beyond the background noise floor.
6. Margin (dB) = Remark result (dBuV/m) – Average limit (dBuV/m).

Operation Mode: Tx / IEEE 802.11n HT 20 mode / 5745 ~ 5825MHz / CH High
Temperature: 27°C
Humidity: 53% RH

Test Date: March 11, 2015
Tested by: Jason Lu
Polarity: Ver. / Hor.

Frequency (MHz)	Reading (dBuV)	Correction (dB/m)	Result (dBuV/m)	Limit (dBuV/m)	Margin (dB)	Remark	Ant.Pol. (H/V)
2379.000	50.99	-3.87	47.12	74.00	-26.88	peak	V
11650.000	37.69	16.91	54.60	74.00	-19.40	peak	V
11650.000	29.41	16.91	46.32	54.00	-7.68	AVG	V
17480.000	35.65	26.24	61.89	74.00	-12.11	peak	V
17480.000	26.39	26.24	52.63	54.00	-1.37	AVG	V
N/A							
2554.000	50.16	-3.01	47.15	74.00	-26.85	peak	H
N/A							

Remark:

1. Measuring frequencies from 1 GHz to the 10th harmonic of highest fundamental frequency.
2. Radiated emissions measured in frequency above 1000MHz were made with an instrument using peak/average detector mode.
3. Average test would be performed if the peak result were greater than the average limit.
4. Data of measurement within this frequency range shown " --- " in the table above means the reading of emissions are attenuated more than 20dB below the permissible limits or the field strength is too small to be measured.
5. Measurements above show only up to 6 maximum emissions noted, or would be lesser, with " N/A " remark, if no specific emissions from the EUT are recorded (ie: margin>20dB from the applicable limit) and considered that's already beyond the background noise floor.
6. Margin (dB) = Remark result (dBuV/m) – Average limit (dBuV/m).

Operation Mode: Tx / IEEE 802.11n HT 40 mode / 5755 ~ 5795MHz / CH Low
Temperature: 27°C
Humidity: 53% RH

Test Date: March 11, 2015
Tested by: Jason Lu
Polarity: Ver. / Hor.

Frequency (MHz)	Reading (dBuV)	Correction (dB/m)	Result (dBuV/m)	Limit (dBuV/m)	Margin (dB)	Remark	Ant.Pol. (H/V)
2575.000	49.81	-2.97	46.84	74.00	-27.16	peak	V
11510.000	40.45	16.79	57.24	74.00	-16.76	peak	V
11510.000	32.16	16.79	48.95	54.00	-5.05	AVG	V
17270.000	35.96	25.42	61.38	74.00	-12.62	peak	V
17270.000	27.03	25.42	52.45	54.00	-1.55	AVG	V
N/A							
2505.000	49.60	-3.11	46.49	74.00	-27.51	peak	H
N/A							

Remark:

1. Measuring frequencies from 1 GHz to the 10th harmonic of highest fundamental frequency.
2. Radiated emissions measured in frequency above 1000MHz were made with an instrument using peak/average detector mode.
3. Average test would be performed if the peak result were greater than the average limit.
4. Data of measurement within this frequency range shown " --- " in the table above means the reading of emissions are attenuated more than 20dB below the permissible limits or the field strength is too small to be measured.
5. Measurements above show only up to 6 maximum emissions noted, or would be lesser, with " N/A " remark, if no specific emissions from the EUT are recorded (ie: margin>20dB from the applicable limit) and considered that's already beyond the background noise floor.
6. Margin (dB) = Remark result (dBuV/m) – Average limit (dBuV/m).

Operation Mode: Tx / IEEE 802.11n HT 40 mode / 5755 ~ 5795MHz / CH High
Temperature: 27°C
Humidity: 53% RH

Test Date: March 11, 2015
Tested by: Jason Lu
Polarity: Ver. / Hor.

Frequency (MHz)	Reading (dBuV)	Correction (dB/m)	Result (dBuV/m)	Limit (dBuV/m)	Margin (dB)	Remark	Ant.Pol. (H/V)
2680.000	49.69	-2.76	46.93	74.00	-27.07	peak	V
11590.000	36.96	16.86	53.82	74.00	-20.18	peak	V
11590.000	31.19	16.86	48.05	54.00	-5.95	AVG	V
17380.000	34.74	25.85	60.59	74.00	-13.41	peak	V
17380.000	27.07	25.85	52.92	54.00	-1.08	AVG	V
N/A							
2533.000	49.72	-3.05	46.67	74.00	-27.33	peak	H
N/A							

Remark:

1. Measuring frequencies from 1 GHz to the 10th harmonic of highest fundamental frequency.
2. Radiated emissions measured in frequency above 1000MHz were made with an instrument using peak/average detector mode.
3. Average test would be performed if the peak result were greater than the average limit.
4. Data of measurement within this frequency range shown " --- " in the table above means the reading of emissions are attenuated more than 20dB below the permissible limits or the field strength is too small to be measured.
5. Measurements above show only up to 6 maximum emissions noted, or would be lesser, with " N/A " remark, if no specific emissions from the EUT are recorded (ie: margin>20dB from the applicable limit) and considered that's already beyond the background noise floor.
6. Margin (dB) = Remark result (dBuV/m) – Average limit (dBuV/m).

Operation Mode: Tx / IEEE 802.11ac VHT80 Mode / 5775MHz / CH Mid
Temperature: 27°C
Humidity: 53% RH

Test Date: March 11, 2015
Tested by: Jason Lu
Polarity: Ver. / Hor.

Frequency (MHz)	Reading (dBuV)	Correction (dB/m)	Result (dBuV/m)	Limit (dBuV/m)	Margin (dB)	Remark	Ant.Pol. (H/V)
2715.000	49.75	-2.69	47.06	74.00	-26.94	peak	V
11590.000	34.93	16.86	51.79	74.00	-22.21	peak	V
N/A							
2645.000	49.46	-2.83	46.63	74.00	-27.37	peak	H
N/A							

Remark:

1. Measuring frequencies from 1 GHz to the 10th harmonic of highest fundamental frequency.
2. Radiated emissions measured in frequency above 1000MHz were made with an instrument using peak/average detector mode.
3. Average test would be performed if the peak result were greater than the average limit or as required by the applicant.
4. Data of measurement within this frequency range shown " --- " in the table above means the reading of emissions are attenuated more than 20dB below the permissible limits or the field strength is too small to be measured.
5. Measurements above show only up to 6 maximum emissions noted, or would be lesser, with " N/A " remark, if no specific emissions from the EUT are recorded (ie: margin>20dB from the applicable limit) and considered that's already beyond the background noise floor.
6. Margin (dB) = Remark result (dBuV/m) – Average limit (dBuV/m).

7.6 POWERLINE CONDUCTED EMISSIONS

LIMIT

According to §15.207(a), except as shown in paragraphs (b) and (c) of this section, for an intentional radiator that is designed to be connected to the public utility (AC) power line, the radio frequency voltage that is conducted back onto the AC power line on any frequency or frequencies within the band 150 kHz to 30 MHz shall not exceed the limits in the following table, as measured using a 50 μ H/50 ohms line impedance stabilization network (LISN). Compliance with the provisions of this paragraph shall be based on the measurement of the radio frequency voltage between each power line and ground at the power terminal. The lower limit applies at the boundary between the frequency ranges.

Frequency Range (MHz)	Limits (dB μ V)	
	Quasi-peak	Average
0.15 to 0.50	66 to 56*	56 to 46*
0.50 to 5	56	46
5 to 30	60	50

* Decreases with the logarithm of the frequency.

TEST CONFIGURATION

See test photographs attached in Appendix 1 for the actual connections between EUT and support equipment.

TEST PROCEDURE

1. The EUT was placed on a table, which is 0.8m above ground plane.
2. Maximum procedure was performed on the six highest emissions to ensure EUT compliance.
3. Repeat above procedures until all frequency measured were complete.

TEST RESULTS

The initial step in collecting conducted data is a spectrum analyzer peak scan of the measurement range. Significant peaks are then marked as shown on the following data page, and these signals are then quasi-peaked.

Test Data

Operation Mode: Normal Link **Test Date:** November 10, 2015
Temperature: 24°C **Tested by:** Dennis Li
Humidity: 50% RH

Freq. (MHz)	QP Reading (dBuV)	AV Reading (dBuV)	Corr. factor (dB/m)	QP Result (dBuV/m)	AV Result (dBuV/m)	QP Limit (dBuV)	AV Limit (dBuV)	QP Margin (dB)	AV Margin (dB)	Note
0.1500	43.79	41.85	9.69	53.48	51.54	66.00	56.00	-12.52	-4.46	L1
0.1980	34.70	32.41	9.68	44.38	42.09	63.69	53.69	-19.31	-11.60	L1
0.2460	43.80	38.82	9.68	53.48	48.50	61.89	51.89	-8.41	-3.39	L1
1.1380	28.79	26.84	10.41	39.20	37.25	56.00	46.00	-16.80	-8.75	L1
5.1180	31.61	29.11	9.85	41.46	38.96	60.00	50.00	-18.54	-11.04	L1
7.2020	30.86	27.94	9.88	40.74	37.82	60.00	50.00	-19.26	-12.18	L1
0.1539	44.37	42.64	9.64	54.01	52.28	65.78	55.79	-11.77	-3.51	L2
0.2020	37.13	35.41	9.64	46.77	45.05	63.52	53.53	-16.75	-8.48	L2
0.4580	27.16	24.57	9.73	36.89	34.30	56.73	46.73	-19.84	-12.43	L2
0.9460	27.81	26.21	10.41	38.22	36.62	56.00	46.00	-17.78	-9.38	L2
1.1380	28.31	24.58	10.37	38.68	34.95	56.00	46.00	-17.32	-11.05	L2
5.8700	31.00	28.94	9.83	40.83	38.77	60.00	50.00	-19.17	-11.23	L2

Remark:

1. Measuring frequencies from 0.15 MHz to 30MHz.
2. The emissions measured in frequency range from 0.15 MHz to 30MHz were made with an instrument using Quasi-peak detector and average detector.
3. The IF bandwidth of SPA between 0.15MHz to 30MHz was 10kHz; the IF bandwidth of Test Receiver between 0.15MHz to 30MHz was 9kHz;
4. L1 = Line One (Live Line) / L2 = Line Two (Neutral Line)

Test Plots

Conducted emissions (Line 1)

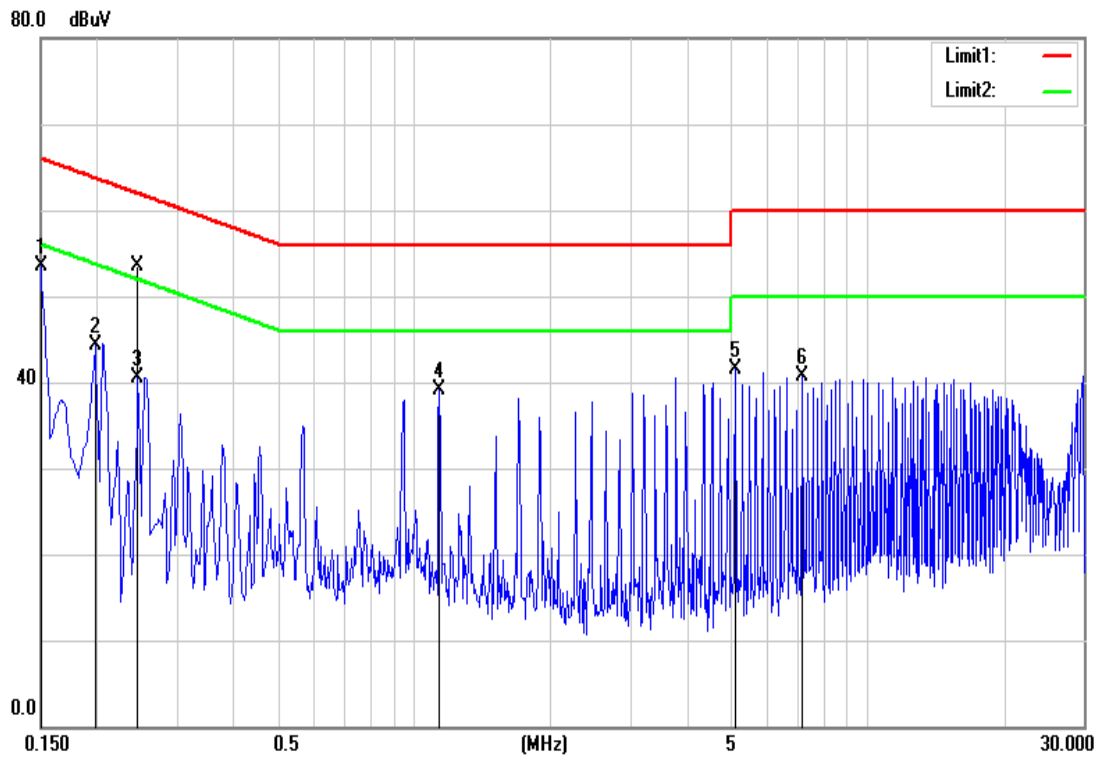

Conducted emissions (Line 2)

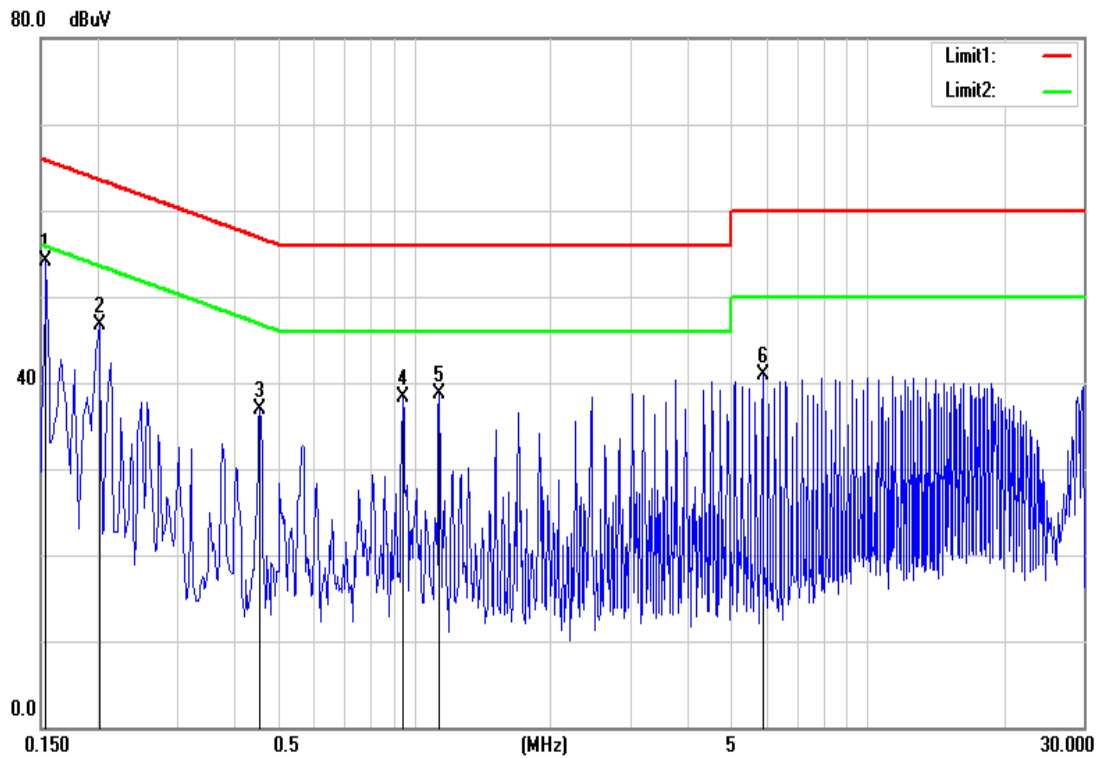

7.7 FREQUENCY STABILITY

LIMIT

According to §15.407(g), manufacturers of U-NII devices are responsible for ensuring frequency stability such that an emission is maintained within the band of operation under all conditions of normal operation as specified in the user's manual.

Test Configuration

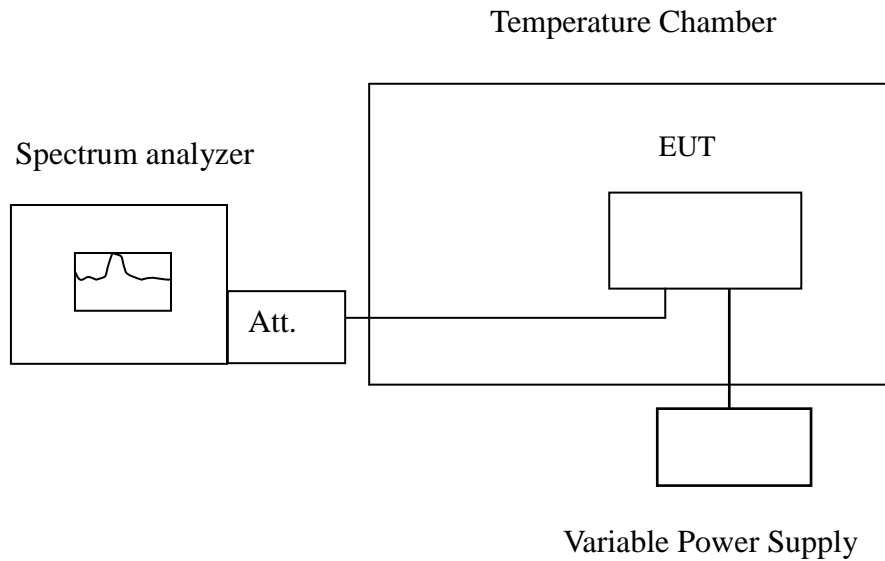

Remark: Measurement setup for testing on Antenna connector

TEST PROCEDURE

The equipment under test was connected to an external AC or DC power supply and input rated voltage. RF output was connected to a frequency counter or spectrum analyzer via feed through attenuators. The EUT was placed inside the temperature chamber. Set the spectrum analyzer RBW low enough to obtain the desired frequency resolution and measure EUT 20°C operating frequency as reference frequency. Turn EUT off and set the chamber temperature to -20°C. After the temperature stabilized for approximately 30 minutes recorded the frequency. Repeat step measure with 10°C increased per stage until the highest temperature of +50°C reached.

TEST RESULTS

No non-compliance noted.

IEEE 802.11a mode / 5180 ~ 5240 MHz:

CH Low

Operating Frequency: 5180 MHz				
Environment Temperature (°C)	Voltage (V)	Measured Frequency (MHz)	Limit Range	Test Result
50	110	5179.992489	5150~5250	Pass
40	110	5180.003508	5150~5250	Pass
30	110	5180.007950	5150~5250	Pass
20	110	5179.999686	5150~5250	Pass
10	110	5180.002704	5150~5250	Pass
0	110	5180.002225	5150~5250	Pass
-10	110	5179.993573	5150~5250	Pass
-20	110	5180.006847	5150~5250	Pass

Operating Frequency: 5180 MHz				
Environment Temperature (°C)	Voltage (V)	Measured Frequency (MHz)	Limit Range	Test Result
20	93.5	5179.999914	5150~5250	Pass
	110	5180.008567	5150~5250	Pass
	126.5	5180.000384	5150~5250	Pass

CH Mid

Operating Frequency: 5220 MHz				
Environment Temperature (°C)	Voltage (V)	Measured Frequency (MHz)	Limit Range	Test Result
50	110	5220.010368	5150~5250	Pass
40	110	5219.997279	5150~5250	Pass
30	110	5219.991427	5150~5250	Pass
20	110	5219.997734	5150~5250	Pass
10	110	5219.995137	5150~5250	Pass
0	110	5219.994515	5150~5250	Pass
-10	110	5219.991357	5150~5250	Pass
-20	110	5219.997468	5150~5250	Pass

Operating Frequency: 5220 MHz				
Environment Temperature (°C)	Voltage (V)	Measured Frequency (MHz)	Limit Range	Test Result
20	93.5	5220.008019	5150~5250	Pass
	110	5220.002422	5150~5250	Pass
	126.5	5219.995538	5150~5250	Pass

CH High

Operating Frequency: 5240 MHz				
Environment Temperature (°C)	Voltage (V)	Measured Frequency (MHz)	Limit Range	Test Result
50	110	5240.007931	5150~5250	Pass
40	110	5239.999188	5150~5250	Pass
30	110	5239.990081	5150~5250	Pass
20	110	5240.006809	5150~5250	Pass
10	110	5239.995058	5150~5250	Pass
0	110	5240.010438	5150~5250	Pass
-10	110	5240.006364	5150~5250	Pass
-20	110	5239.994033	5150~5250	Pass

Operating Frequency: 5240 MHz				
Environment Temperature (°C)	Voltage (V)	Measured Frequency (MHz)	Limit Range	Test Result
20	93.5	5239.998426	5150~5250	Pass
	110	5239.99931	5150~5250	Pass
	126.5	5240.003749	5150~5250	Pass

IEEE 802.11n HT 20 mode / 5180 ~ 5240 MHz / Chain 0:

CH Low

Operating Frequency: 5180 MHz				
Environment Temperature (°C)	Voltage (V)	Measured Frequency (MHz)	Limit Range	Test Result
50	110	5180.009899	5150~5250	Pass
40	110	5180.010657	5150~5250	Pass
30	110	5179.995973	5150~5250	Pass
20	110	5179.998408	5150~5250	Pass
10	110	5180.005465	5150~5250	Pass
0	110	5180.000846	5150~5250	Pass
-10	110	5180.004513	5150~5250	Pass
-20	110	5179.999152	5150~5250	Pass

Operating Frequency: 5180 MHz				
Environment Temperature (°C)	Voltage (V)	Measured Frequency (MHz)	Limit Range	Test Result
20	93.5	5180.004478	5150~5250	Pass
	110	5180.006776	5150~5250	Pass
	126.5	5179.990615	5150~5250	Pass

CH Mid

Operating Frequency: 5220 MHz				
Environment Temperature (°C)	Voltage (V)	Measured Frequency (MHz)	Limit Range	Test Result
50	110	5219.993434	5150~5250	Pass
40	110	5219.997416	5150~5250	Pass
30	110	5219.997870	5150~5250	Pass
20	110	5220.003496	5150~5250	Pass
10	110	5219.991072	5150~5250	Pass
0	110	5220.005607	5150~5250	Pass
-10	110	5219.999724	5150~5250	Pass
-20	110	5219.995243	5150~5250	Pass

Operating Frequency: 5220 MHz				
Environment Temperature (°C)	Voltage (V)	Measured Frequency (MHz)	Limit Range	Test Result
20	93.5	5220.002723	5150~5250	Pass
	110	5219.991762	5150~5250	Pass
	126.5	5220.00687	5150~5250	Pass

CH High

Operating Frequency: 5240 MHz				
Environment Temperature (°C)	Voltage (V)	Measured Frequency (MHz)	Limit Range	Test Result
50	110	5239.992864	5150~5250	Pass
40	110	5239.995485	5150~5250	Pass
30	110	5240.003504	5150~5250	Pass
20	110	5240.001065	5150~5250	Pass
10	110	5239.995947	5150~5250	Pass
0	110	5239.995833	5150~5250	Pass
-10	110	5240.001089	5150~5250	Pass
-20	110	5240.008850	5150~5250	Pass

Operating Frequency: 5240 MHz				
Environment Temperature (°C)	Voltage (V)	Measured Frequency (MHz)	Limit Range	Test Result
20	93.5	5240.000339	5150~5250	Pass
	110	5239.996732	5150~5250	Pass
	126.5	5240.007115	5150~5250	Pass

IEEE 802.11n HT 20 mode / 5180 ~ 5240 MHz / Chain 1:

CH Low

Operating Frequency: 5180 MHz				
Environment Temperature (°C)	Voltage (V)	Measured Frequency (MHz)	Limit Range	Test Result
50	110	5179.995478	5150~5250	Pass
40	110	5180.003998	5150~5250	Pass
30	110	5180.007977	5150~5250	Pass
20	110	5179.997855	5150~5250	Pass
10	110	5180.001380	5150~5250	Pass
0	110	5179.995838	5150~5250	Pass
-10	110	5179.996846	5150~5250	Pass
-20	110	5179.997308	5150~5250	Pass

Operating Frequency: 5180 MHz				
Environment Temperature (°C)	Voltage (V)	Measured Frequency (MHz)	Limit Range	Test Result
20	93.5	5179.990103	5150~5250	Pass
	110	5180.003557	5150~5250	Pass
	126.5	5179.994124	5150~5250	Pass

CH Mid

Operating Frequency: 5220 MHz				
Environment Temperature (°C)	Voltage (V)	Measured Frequency (MHz)	Limit Range	Test Result
50	110	5220.007674	5150~5250	Pass
40	110	5220.009327	5150~5250	Pass
30	110	5219.998817	5150~5250	Pass
20	110	5220.003164	5150~5250	Pass
10	110	5219.995494	5150~5250	Pass
0	110	5220.006142	5150~5250	Pass
-10	110	5219.992005	5150~5250	Pass
-20	110	5220.004593	5150~5250	Pass

Operating Frequency: 5220 MHz				
Environment Temperature (°C)	Voltage (V)	Measured Frequency (MHz)	Limit Range	Test Result
20	93.5	5220.005023	5150~5250	Pass
	110	5219.993043	5150~5250	Pass
	126.5	5220.008269	5150~5250	Pass

CH High

Operating Frequency: 5240 MHz				
Environment Temperature (°C)	Voltage (V)	Measured Frequency (MHz)	Limit Range	Test Result
50	110	5239.999613	5150~5250	Pass
40	110	5240.005530	5150~5250	Pass
30	110	5240.010947	5150~5250	Pass
20	110	5240.005739	5150~5250	Pass
10	110	5240.007769	5150~5250	Pass
0	110	5240.002491	5150~5250	Pass
-10	110	5239.996935	5150~5250	Pass
-20	110	5239.995111	5150~5250	Pass

Operating Frequency: 5240 MHz				
Environment Temperature (°C)	Voltage (V)	Measured Frequency (MHz)	Limit Range	Test Result
20	93.5	5240.008764	5150~5250	Pass
	110	5240.010976	5150~5250	Pass
	126.5	5240.002991	5150~5250	Pass

IEEE 802.11n HT 40 mode / 5190 ~ 5230 MHz / Chain 0:

CH Low

Operating Frequency: 5190 MHz				
Environment Temperature (°C)	Voltage (V)	Measured Frequency (MHz)	Limit Range	Test Result
50	110	5189.996351	5150~5250	Pass
40	110	5189.998199	5150~5250	Pass
30	110	5189.990531	5150~5250	Pass
20	110	5190.010897	5150~5250	Pass
10	110	5189.998080	5150~5250	Pass
0	110	5190.008442	5150~5250	Pass
-10	110	5189.990740	5150~5250	Pass
-20	110	5190.005573	5150~5250	Pass

Operating Frequency: 5190 MHz				
Environment Temperature (°C)	Voltage (V)	Measured Frequency (MHz)	Limit Range	Test Result
20	93.5	5190.00527	5150~5250	Pass
	110	5189.990533	5150~5250	Pass
	126.5	5189.997485	5150~5250	Pass

CH High

Operating Frequency: 5230 MHz				
Environment Temperature (°C)	Voltage (V)	Measured Frequency (MHz)	Limit Range	Test Result
50	110	5229.992725	5150~5250	Pass
40	110	5229.992937	5150~5250	Pass
30	110	5230.004852	5150~5250	Pass
20	110	5230.006512	5150~5250	Pass
10	110	5229.991012	5150~5250	Pass
0	110	5229.997563	5150~5250	Pass
-10	110	5230.003048	5150~5250	Pass
-20	110	5230.001650	5150~5250	Pass

Operating Frequency: 5230 MHz				
Environment Temperature (°C)	Voltage (V)	Measured Frequency (MHz)	Limit Range	Test Result
20	93.5	5230.005468	5150~5250	Pass
	110	5230.004303	5150~5250	Pass
	126.5	5230.001012	5150~5250	Pass

IEEE 802.11n HT 40 mode / 5190 ~ 5230 MHz / Chain 1:

CH Low

Operating Frequency: 5190 MHz				
Environment Temperature (°C)	Voltage (V)	Measured Frequency (MHz)	Limit Range	Test Result
50	110	5189.993602	5150~5250	Pass
40	110	5189.995644	5150~5250	Pass
30	110	5190.010078	5150~5250	Pass
20	110	5189.995822	5150~5250	Pass
10	110	5190.010393	5150~5250	Pass
0	110	5190.006966	5150~5250	Pass
-10	110	5189.999690	5150~5250	Pass
-20	110	5190.009055	5150~5250	Pass

Operating Frequency: 5190 MHz				
Environment Temperature (°C)	Voltage (V)	Measured Frequency (MHz)	Limit Range	Test Result
20	93.5	5190.00356	5150~5250	Pass
	110	5189.997196	5150~5250	Pass
	126.5	5190.009609	5150~5250	Pass

CH High

Operating Frequency: 5230 MHz				
Environment Temperature (°C)	Voltage (V)	Measured Frequency (MHz)	Limit Range	Test Result
50	110	5229.992159	5150~5250	Pass
40	110	5229.994806	5150~5250	Pass
30	110	5229.995250	5150~5250	Pass
20	110	5230.008945	5150~5250	Pass
10	110	5230.008010	5150~5250	Pass
0	110	5230.008842	5150~5250	Pass
-10	110	5230.010452	5150~5250	Pass
-20	110	5230.006327	5150~5250	Pass

Operating Frequency: 5230 MHz				
Environment Temperature (°C)	Voltage (V)	Measured Frequency (MHz)	Limit Range	Test Result
20	93.5	5229.991995	5150~5250	Pass
	110	5230.002941	5150~5250	Pass
	126.5	5230.006523	5150~5250	Pass

IEEE 802.11ac VHT80 Mode / Chain 0:

CH Mid

Operating Frequency: 5210 MHz				
Environment Temperature (°C)	Voltage (V)	Measured Frequency (MHz)	Limit Range	Test Result
50	110	5210.004235	5150~5250	Pass
40	110	5209.991789	5150~5250	Pass
30	110	5210.005995	5150~5250	Pass
20	110	5210.006483	5150~5250	Pass
10	110	5210.000320	5150~5250	Pass
0	110	5210.003763	5150~5250	Pass
-10	110	5210.001062	5150~5250	Pass
-20	110	5210.004021	5150~5250	Pass

Operating Frequency: 5210 MHz				
Environment Temperature (°C)	Voltage (V)	Measured Frequency (MHz)	Limit Range	Test Result
20	93.5	5210.003545	5150~5250	Pass
	110	5209.994263	5150~5250	Pass
	126.5	5209.992108	5150~5250	Pass

IEEE 802.11ac VHT80 Mode / Chain 1:

CH Mid

Operating Frequency: 5210 MHz				
Environment Temperature (°C)	Voltage (V)	Measured Frequency (MHz)	Limit Range	Test Result
50	110	5209.998025	5150~5250	Pass
40	110	5209.997427	5150~5250	Pass
30	110	5209.991144	5150~5250	Pass
20	110	5209.990164	5150~5250	Pass
10	110	5209.998416	5150~5250	Pass
0	110	5210.000089	5150~5250	Pass
-10	110	5210.001610	5150~5250	Pass
-20	110	5209.990823	5150~5250	Pass

Operating Frequency: 5210 MHz				
Environment Temperature (°C)	Voltage (V)	Measured Frequency (MHz)	Limit Range	Test Result
20	93.5	5210.002097	5150~5250	Pass
	110	5210.003522	5150~5250	Pass
	126.5	5210.000731	5150~5250	Pass