



Hermon Laboratories Ltd.
Harakevet Industrial Zone, Binyamina 30500,
Israel
Tel. +972-4-6288001
Fax. +972-4-6288277
E-mail: mail@hermonlabs.com

TEST REPORT

ACCORDING TO: FCC 47CFR part 27

FOR:

Siemens Israel Ltd.
Base Station Transceiver
Model: WIN7025 (cBST)
FCC ID: VG5WIN7025

This report is in conformity with ISO/IEC 17025. The "A2LA Accredited" symbol endorsement applies only to the tests and calibrations that are listed in the scope of Hermon Laboratories accreditation. The test results relate only to the items tested. This test report shall not be reproduced in any form except in full with the written approval of Hermon Laboratories Ltd.

Table of contents

1	Applicant information.....	3
2	Equipment under test attributes	3
3	Manufacturer information	3
4	Test details.....	3
5	Tests summary.....	4
6	EUT description.....	5
6.1	General information.....	5
6.2	Ports and lines	5
6.3	Support and test equipment	5
6.4	Changes made in the EUT	5
6.5	Test configuration.....	5
6.6	Transmitter characteristics	6
7	Transmitter tests according to 47CFR part 27 requirements.....	7
7.1	Occupied bandwidth test.....	7
7.2	Peak output power test.....	19
7.3	Band edge emissions at RF connector test.....	30
7.4	Spurious emissions at RF antenna connector test.....	46
7.5	Radiated spurious emission measurements.....	59
7.6	Frequency stability test.....	73
8	APPENDIX A Test equipment and ancillaries used for tests.....	82
9	APPENDIX B Measurement uncertainties.....	83
10	APPENDIX C Test facility description	84
11	APPENDIX D Specification references	84
13	APPENDIX E Test equipment correction factors.....	85
14	APPENDIX F Abbreviations and acronyms.....	93

1 Applicant information

Client name: Siemens Canada Limited
Address: 300 Applewood Crescent, Unit 1, Concord, Ontario, Canada
Telephone: (905) 482 4558
Fax: (905) 856 1995
E-mail: Israel.Aminov@siemens.com
Contact name: Mr. Israel Aminov

2 Equipment under test attributes

Product name: Base Station operating in 2.5 GHz
Product type: Transceiver
Model(s): WIN7025 (cBST)
Serial number: 12541611030
Hardware version: A6
Software release: 4.4
Receipt date: 20-Jul-15

3 Manufacturer information

Manufacturer name: Siemens Israel Ltd.
Address: 14 Hamelaha street, Rosh Ha Ayin 4809134, Israel
Telephone: +972 73 266 0014
Fax: +972 3915 1522
E-Mail: Yair.Amran@siemens.com
Contact name: Mr. Yair Amran



4 Test details

Project ID: 27275
Location: Hermon Laboratories Ltd. Harakevet Industrial Zone, Binyamina 30500, Israel
Test started: 20-Jul-15
Test completed: 03-Aug-15
Test specification(s): FCC 47CFR part 27

5 Tests summary

Test	Status
Transmitter characteristics	
Section 27.50(h)(1), Peak output power	Pass
Section 27.50(h)(4), Spectral power density	Pass
Section 27.52, RF exposure	Pass, Exhibit provided in Application for certification
Section 27.53(m)(2), Spurious emissions at RF antenna connector	Pass
Section 27.53(m)(2), Band edge emissions at RF antenna connector	Pass
Section 27.53(m)(2), Radiated spurious emissions	Pass
Section 2.1049, Occupied bandwidth	Pass
Section 27.54, Frequency stability	Pass

Testing was completed against all relevant requirements of the test standard. The results obtained indicate that the product under test complies in full with the requirements tested.
The test results relate only to the items tested. Pass/ fail decision was based on nominal values.

	Name and Title	Date	Signature
Tested by:	Mr. S. Samokha, test engineer	August 3, 2015	
Reviewed by:	Mrs. M. Cherniavsky, certification engineer	September 1, 2015	
Approved by:	Mr. M. Nikishin, EMC and Radio group manager	December 20, 2015	

6 EUT description

6.1 General information

The EUT, model Win7025, is base station of WiMAX system, comprises an Outdoor Unit (ODU) that includes modem, radio, data processing and management components, serving as an efficient platform for a wide range of services. It provides a wireless connection to the subscriber unit.

6.2 Ports and lines

Port type	Port description	Connected		Connector type	Qty.	Cable type	Cable length
		From	To				
Signal	48 V DC & Ethernet	EUT	DC power supply	Custom	2	shielded	30 m
			Laptop				
RF	Antenna	EUT	50 Ohm termination	N-type	2	NA	NA

6.3 Support and test equipment

Description	Manufacturer	Model number	Serial number
Laptop	LENOVO	X220	R9-H42YV11/10

6.4 Changes made in the EUT

No changes were implemented in the EUT during testing.

6.5 Test configuration

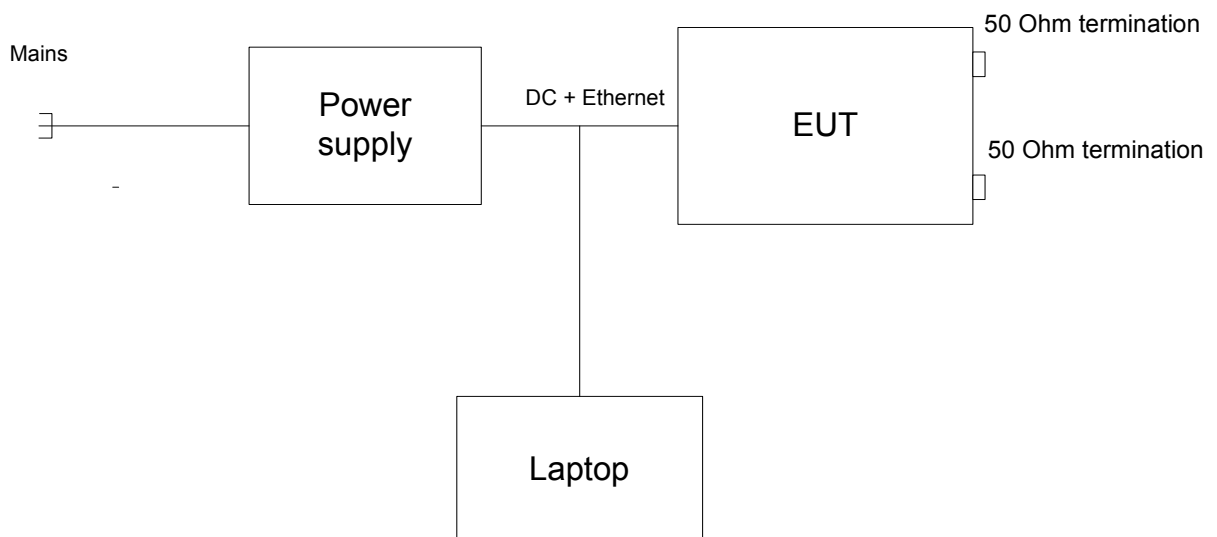



6.6 Transmitter characteristics

Type of equipment									
<input checked="" type="checkbox"/>	Stand-alone (Equipment with or without its own control provisions)								
<input type="checkbox"/>	Combined equipment (Equipment where the radio part is fully integrated within another type of equipment)								
<input type="checkbox"/>	Plug-in card (Equipment intended for a variety of host systems)								
Intended use		Condition of use							
<input checked="" type="checkbox"/>	fixed	Always at a distance more than 2 m from all people							
<input type="checkbox"/>	mobile	Always at a distance more than 20 cm from all people							
<input type="checkbox"/>	portable	May operate at a distance closer than 20 cm to human body							
Assigned frequency range		2496 – 2690 MHz							
Operating frequency range		2498.5 – 2687.5 MHz							
RF channel bandwidth		5 MHz, 10 MHz							
Maximum rated output power		At transmitter 50 Ω RF output connector	38.16 dBm						
Is transmitter output power variable?		No							
		continuous variable							
		<input checked="" type="checkbox"/>	Yes	<input checked="" type="checkbox"/>	stepped variable with stepsize	0.5 dB			
		minimum RF power		21 dBm					
		maximum EIRP power		56.16 dBm					
Antenna connection									
<input type="checkbox"/>	unique coupling	<input type="checkbox"/>	standard connector	<input checked="" type="checkbox"/>	Integral	<input checked="" type="checkbox"/>	with temporary RF connector	<input type="checkbox"/>	without temporary RF connector
Antenna/s technical characteristics									
Type	Manufacturer	Model number	Gain						
Dual slant base station	MTI WIRELESS EDGE LTD	MT-364054/ND/A	17±1 dBi						
Dual polarization broadband sector panel	Tongyu Communication Equipment Co., Ltd.	TDJ-232716D-90PT0	16 dBi						
Dual slant base station	PCTEL	SP2327-16XP65	16.5 dBi						
Dual Polarization	KENBOTONG	KBT90DP16-2327	16 dBi						
Transmitter 99% power bandwidth		5 MHz, 10 MHz							
Transmitter aggregate data rate/s		5 MHz BW: QPSK - 4.19 MBps, 16QAM – 12.565 MBps, 64QAM – 18.85 MBps 10 MHz BW: QPSK - 8.38 MBps, 16QAM – 25.13 MBps, 64QAM – 37.7 MBps							
Type of modulation		QPSK, 16QAM, 64QAM							
Type of multiplexing		OFDM							
Modulating test signal (baseband)		PRBS							
Maximum transmitter duty cycle in normal use		100%							
Transmitter power source									
		Nominal rated voltage	Battery type						
<input checked="" type="checkbox"/>	DC	Nominal rated voltage	48 V (via DC power supply from the mains)						
	AC mains	Nominal rated voltage	Frequency						
Common power source for transmitter and receiver		<input checked="" type="checkbox"/>	yes	<input type="checkbox"/>	no				



Test specification:		Section 2.1049, Occupied bandwidth	
Test procedure:		47 CFR, Section 2.1049	
Test mode:		Compliance	
Date(s):		22-Jul-15 - 23-Jul-15	
Temperature: 23 °C		Air Pressure: 1005 hPa	
		Relative Humidity: 48 %	
		Power Supply: 48 VDC	
Remarks:			

7 Transmitter tests according to 47CFR part 27 requirements

7.1 Occupied bandwidth test

7.1.1 General

This test was performed to measure transmitter occupied bandwidth. Specification test limits are given in Table 7.1.1.

Table 7.1.1 Occupied bandwidth limits

Assigned frequency, MHz	Modulation envelope reference points*, dBc	Maximum allowed bandwidth, kHz
2496.0 – 2690.0	26	NA

* - Modulation envelope reference points are provided in terms of attenuation below the unmodulated carrier.

7.1.2 Test procedure

7.1.2.1 The EUT was set up as shown in Figure 7.1.1, energized and its proper operation was checked.

7.1.2.2 The EUT was set to transmit the modulated carrier and the reference peak power level was measured.

7.1.2.3 The EUT was set to transmit the normally modulated carrier.

7.1.2.4 The transmitter occupied bandwidth was measured with spectrum analyzer as a frequency delta between the reference points on modulation envelope and provided in Table 7.1.2, Table 7.1.3 and the associated plots.

Figure 7.1.1 Occupied bandwidth test setup

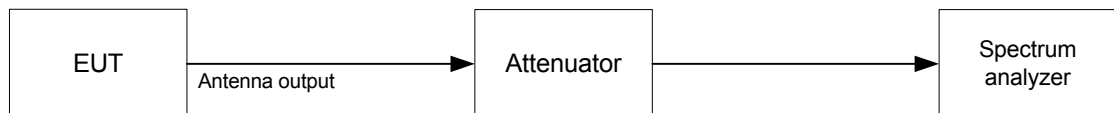



Test specification:		Section 2.1049, Occupied bandwidth	
Test procedure:		47 CFR, Section 2.1049	
Test mode:		Compliance	
Date(s):		22-Jul-15 - 23-Jul-15	
Temperature: 23 °C		Air Pressure: 1005 hPa	
		Relative Humidity: 48 %	
		Power Supply: 48 VDC	
Remarks:			

Table 7.1.2 Occupied bandwidth test results

DETECTOR USED: Average
 RESOLUTION BANDWIDTH: 100 kHz (0.5-2% of OBW)
 VIDEO BANDWIDTH: 1000 kHz
 MODULATION ENVELOPE REFERENCE POINTS: 26 dBc
 RF CHANNEL BW: 5 MHz
 MODULATING SIGNAL: PRBS

MODULATION: QPSK
 BIT RATE: 4.19 Mbps

Carrier frequency, MHz	Occupied bandwidth, MHz	Limit, kHz	Margin, kHz	Verdict
2498.5	4.887	NA	NA	Pass
2575.0	4.884	NA	NA	Pass
2687.5	4.885	NA	NA	Pass

MODULATION: 16QAM
 BIT RATE: 12.565 Mbps

Carrier frequency, MHz	Occupied bandwidth, MHz	Limit, kHz	Margin, kHz	Verdict
2498.5	4.862	NA	NA	Pass
2575.0	4.958	NA	NA	Pass
2687.5	4.860	NA	NA	Pass

MODULATION: 64QAM
 BIT RATE: 18.85 Mbps

Carrier frequency, MHz	Occupied bandwidth, MHz	Limit, kHz	Margin, kHz	Verdict
2498.5	4.938	NA	NA	Pass
2575.0	4.936	NA	NA	Pass
2687.5	4.938	NA	NA	Pass



Test specification:		Section 2.1049, Occupied bandwidth	
Test procedure:		47 CFR, Section 2.1049	
Test mode:		Compliance	
Date(s):		22-Jul-15 - 23-Jul-15	
Temperature: 23 °C		Air Pressure: 1005 hPa	
		Relative Humidity: 48 %	
		Power Supply: 48 VDC	
Remarks:			

Table 7.1.3 Occupied bandwidth test results

DETECTOR USED: Average
RESOLUTION BANDWIDTH: 100 kHz (0.5-2% of OBW)
VIDEO BANDWIDTH: 1000 kHz
MODULATION ENVELOPE REFERENCE POINTS: 26 dBc
RF CHANNEL BW: 10 MHz
MODULATING SIGNAL: PRBS

MODULATION: QPSK
BIT RATE: 8.38 MBps

Carrier frequency, MHz	Occupied bandwidth, MHz	Limit, kHz	Margin, kHz	Verdict
2501.0	9.561	NA	NA	Pass
2596.0	9.562	NA	NA	Pass
2685.0	9.562	NA	NA	Pass

MODULATION: 16QAM
BIT RATE: 25.13 MBps

Carrier frequency, MHz	Occupied bandwidth, MHz	Limit, kHz	Margin, kHz	Verdict
2501.0	9.667	NA	NA	Pass
2596.0	9.606	NA	NA	Pass
2685.0	9.667	NA	NA	Pass

MODULATION: 64QAM
BIT RATE: 37.7 MBps

Carrier frequency, MHz	Occupied bandwidth, MHz	Limit, kHz	Margin, kHz	Verdict
2501.0	9.607	NA	NA	Pass
2596.0	9.561	NA	NA	Pass
2685.0	9.563	NA	NA	Pass

Reference numbers of test equipment used

HL 3301	HL 3302	HL 3667	HL 3818	HL 4293			
---------	---------	---------	---------	---------	--	--	--

Full description is given in Appendix A.



HERMON LABORATORIES

Test specification: Section 2.1049, Occupied bandwidth			
Test procedure: 47 CFR, Section 2.1049			
Test mode: Compliance			Verdict: PASS
Date(s): 22-Jul-15 - 23-Jul-15			
Temperature: 23 °C	Air Pressure: 1005 hPa	Relative Humidity: 48 %	Power Supply: 48 VDC
Remarks:			

Plot 7.1.1 Occupied bandwidth test result at low frequency, 5 MHz BW, QPSK (2498.5 MHz)

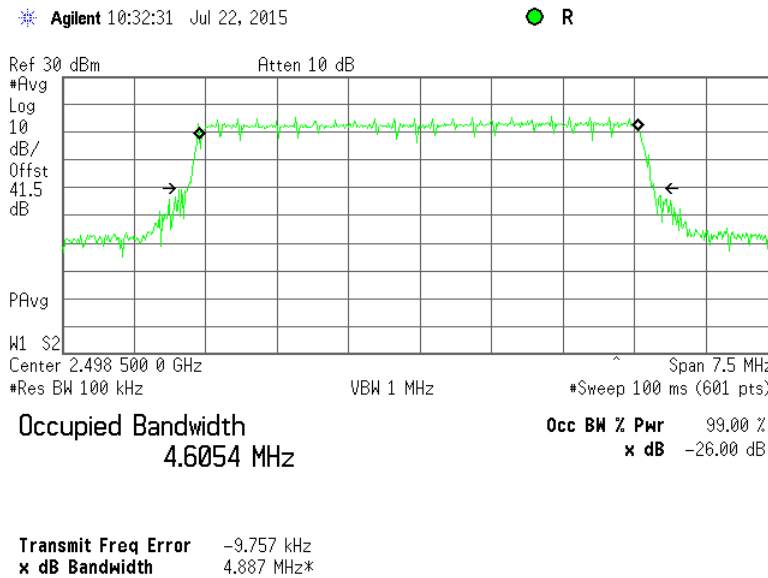

Plot 7.1.2 Occupied bandwidth test result at mid frequency, 5 MHz BW, QPSK (2575.0 MHz)

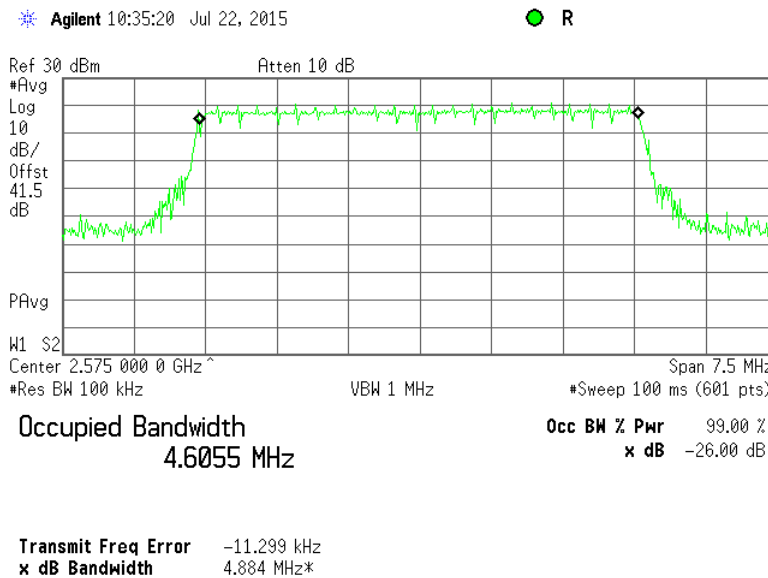



Test specification:		Section 2.1049, Occupied bandwidth	
Test procedure:		47 CFR, Section 2.1049	
Test mode:		Compliance	
Date(s):		22-Jul-15 - 23-Jul-15	
Temperature: 23 °C		Air Pressure: 1005 hPa	
Relative Humidity: 48 %		Power Supply: 48 VDC	
Remarks:			
		Verdict: PASS	

Plot 7.1.3 Occupied bandwidth test result at high frequency, 5 MHz BW, QPSK (2687.5 MHz)

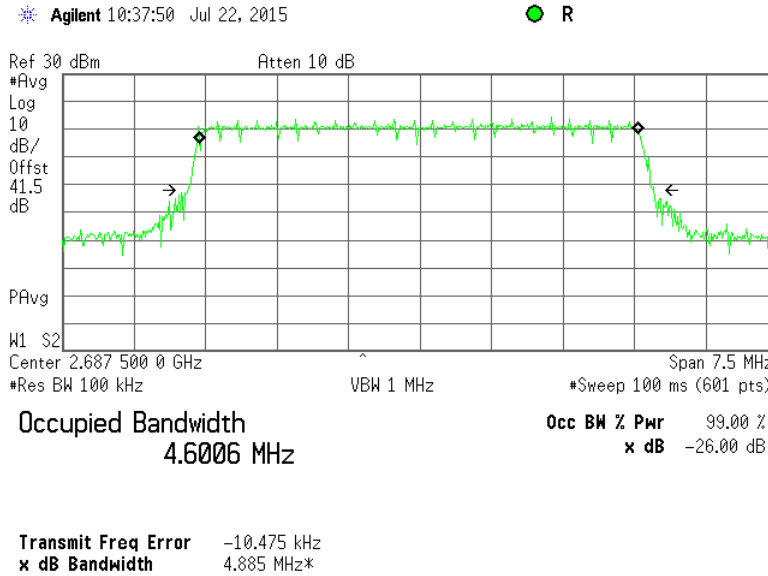

Plot 7.1.4 Occupied bandwidth test result at low frequency, 10 MHz BW, QPSK (2501.0 MHz)

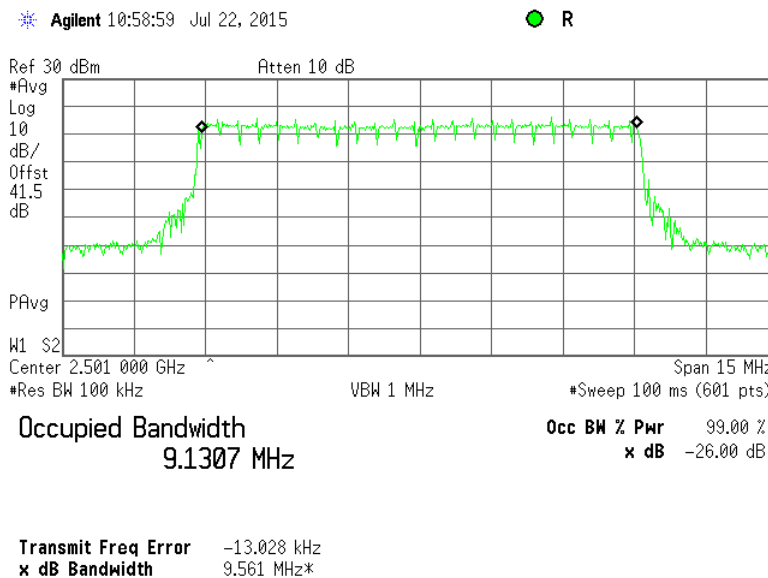



Test specification:		Section 2.1049, Occupied bandwidth	
Test procedure:		47 CFR, Section 2.1049	
Test mode:		Compliance	
Date(s):		22-Jul-15 - 23-Jul-15	
Temperature: 23 °C		Air Pressure: 1005 hPa	
Relative Humidity: 48 %		Power Supply: 48 VDC	
Remarks:			
		Verdict: PASS	

Plot 7.1.5 Occupied bandwidth test result at mid frequency, 10 MHz BW, QPSK (2596.0MHz)

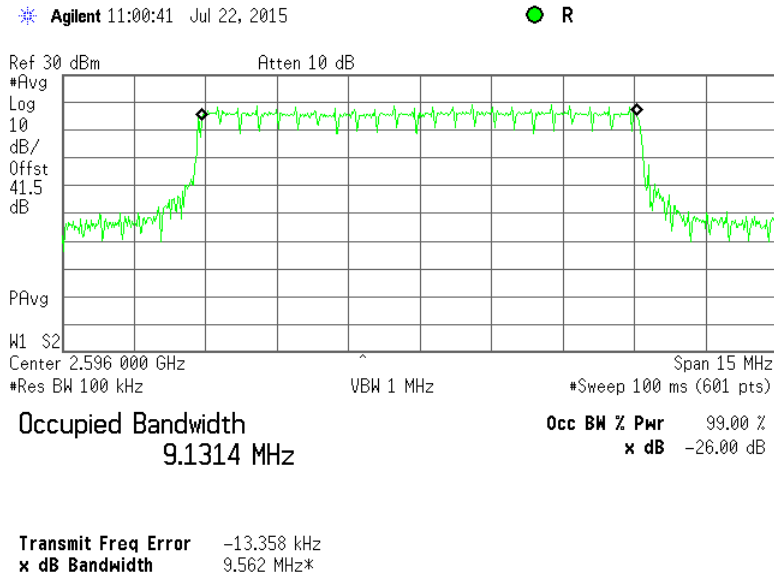

Plot 7.1.6 Occupied bandwidth test result at high frequency, 10 MHz BW, QPSK (2685.0MHz)

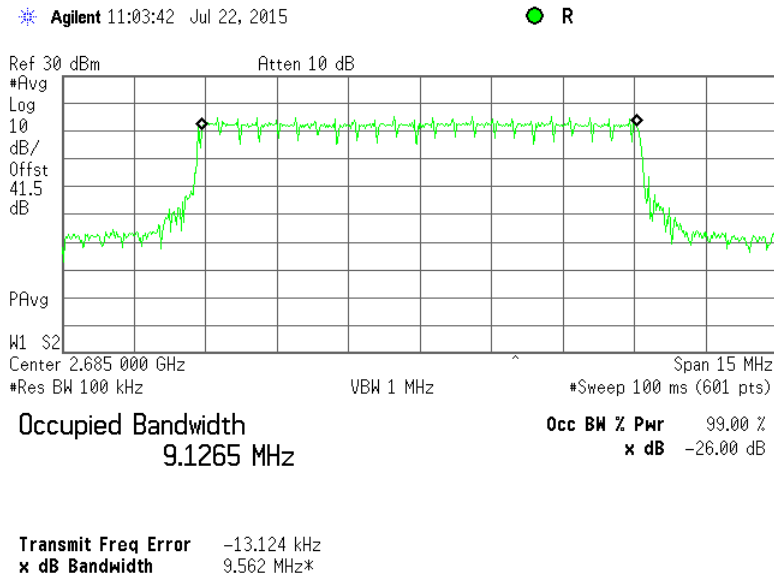



Test specification:		Section 2.1049, Occupied bandwidth	
Test procedure:		47 CFR, Section 2.1049	
Test mode:		Compliance	
Date(s):		22-Jul-15 - 23-Jul-15	
Temperature: 23 °C		Air Pressure: 1005 hPa	
Relative Humidity: 48 %		Power Supply: 48 VDC	
Remarks:			
		Verdict: PASS	

Plot 7.1.7 Occupied bandwidth test result at low frequency, 5 MHz BW, 16QAM (2498.5 MHz)

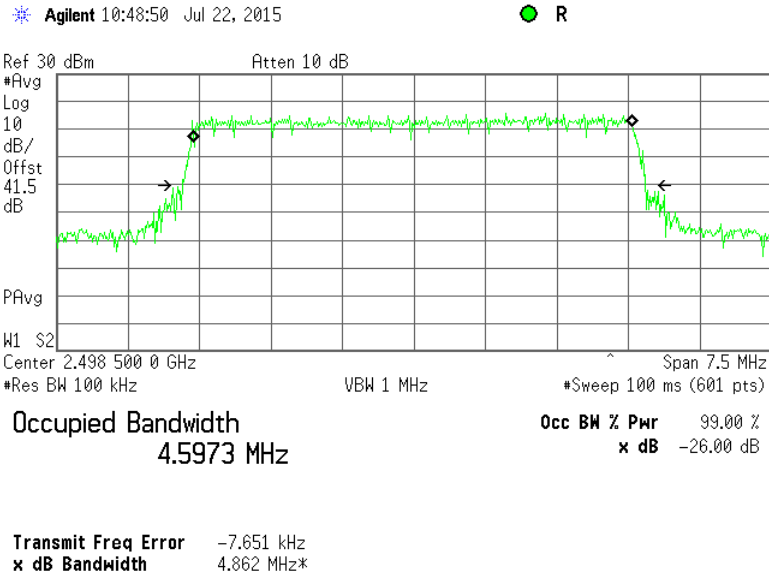

Plot 7.1.8 Occupied bandwidth test result at mid frequency, 5 MHz BW, 16QAM (2575.0 MHz)

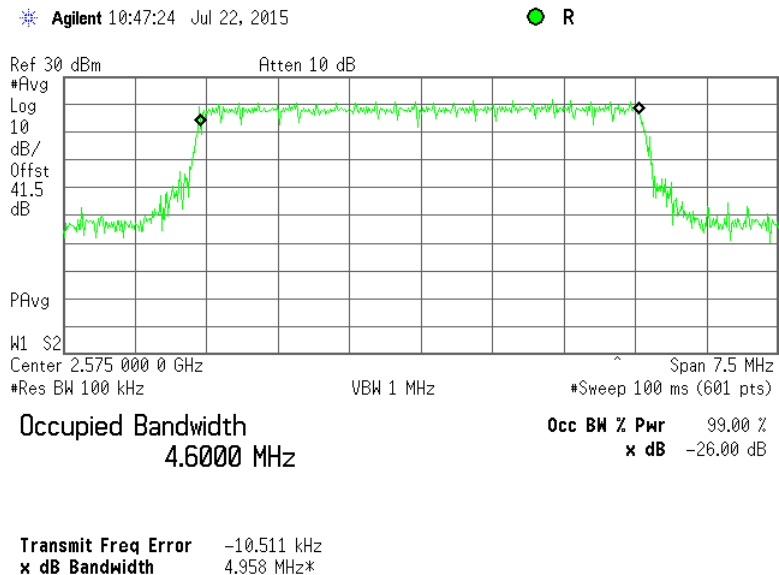



HERMON LABORATORIES

Test specification: Section 2.1049, Occupied bandwidth			
Test procedure: 47 CFR, Section 2.1049			
Test mode: Compliance			Verdict: PASS
Date(s): 22-Jul-15 - 23-Jul-15			
Temperature: 23 °C	Air Pressure: 1005 hPa	Relative Humidity: 48 %	Power Supply: 48 VDC
Remarks:			

Plot 7.1.9 Occupied bandwidth test result at high frequency, 5 MHz BW, 16QAM (2687.5 MHz)

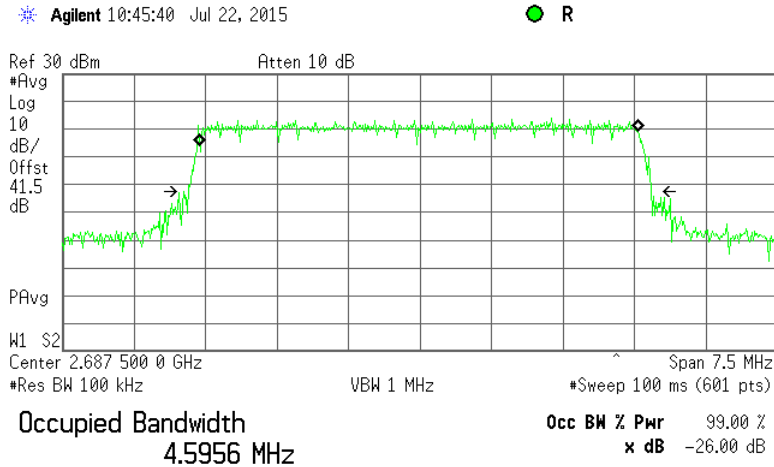

Transmit Freq Error -9.101 kHz
x dB Bandwidth 4.860 MHz*

Plot 7.1.10 Occupied bandwidth test result at low frequency, 10 MHz BW, 16QAM (2501.0MHz)

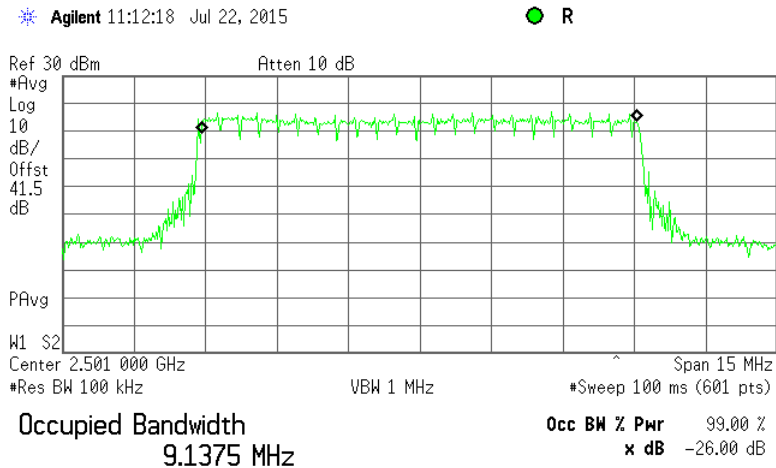

Transmit Freq Error -17.660 kHz
x dB Bandwidth 9.667 MHz*



Test specification: Section 2.1049, Occupied bandwidth			
Test procedure: 47 CFR, Section 2.1049			
Test mode: Compliance		Verdict: PASS	
Date(s): 22-Jul-15 - 23-Jul-15			
Temperature: 23 °C	Air Pressure: 1005 hPa	Relative Humidity: 48 %	Power Supply: 48 VDC
Remarks:			

Plot 7.1.11 Occupied bandwidth test result at mid frequency, 10 MHz BW, 16QAM (2596.0 MHz)

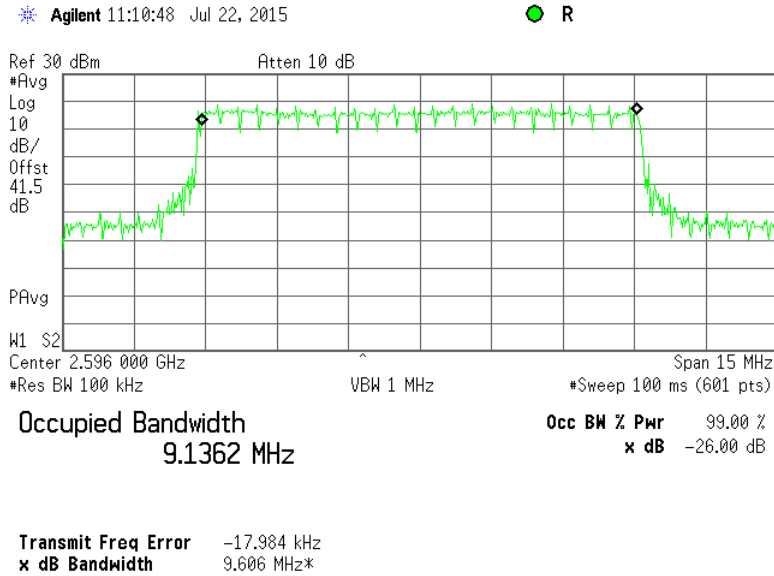

Plot 7.1.12 Occupied bandwidth test result at high frequency, 10 MHz BW, 16QAM (2685.0 MHz)

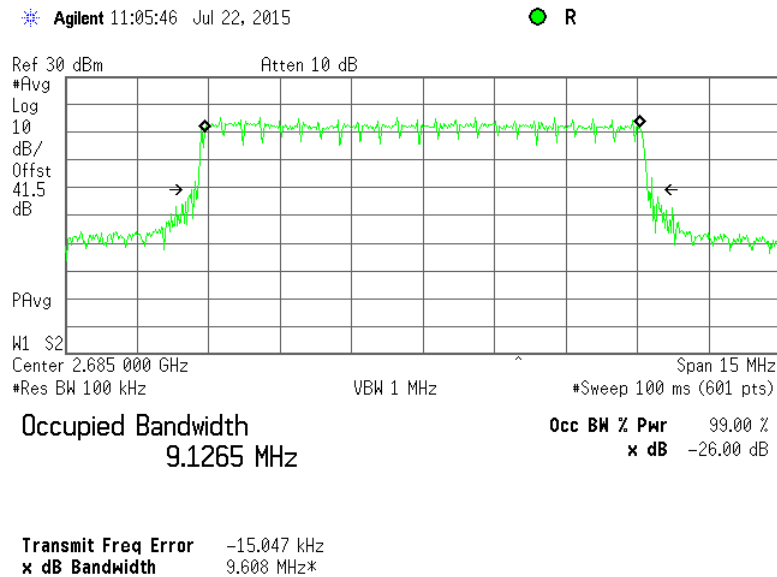



Test specification:		Section 2.1049, Occupied bandwidth	
Test procedure:		47 CFR, Section 2.1049	
Test mode:		Compliance	
Date(s):		22-Jul-15 - 23-Jul-15	
Temperature: 23 °C		Air Pressure: 1005 hPa	
Relative Humidity: 48 %		Power Supply: 48 VDC	
Remarks:			
		Verdict: PASS	

Plot 7.1.13 Occupied bandwidth test result at low frequency, 5 MHz BW, 64QAM (2498.5 MHz)

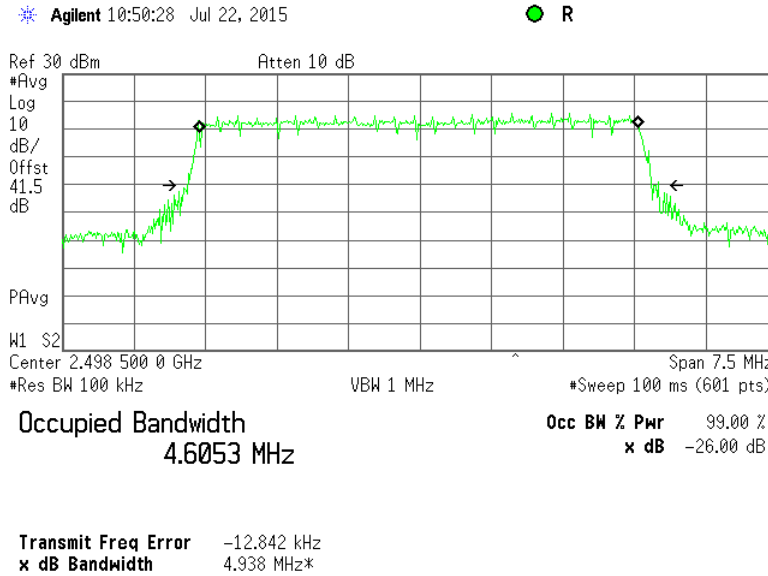

Plot 7.1.14 Occupied bandwidth test result at mid frequency, 5 MHz BW, 64QAM (2575.0 MHz)

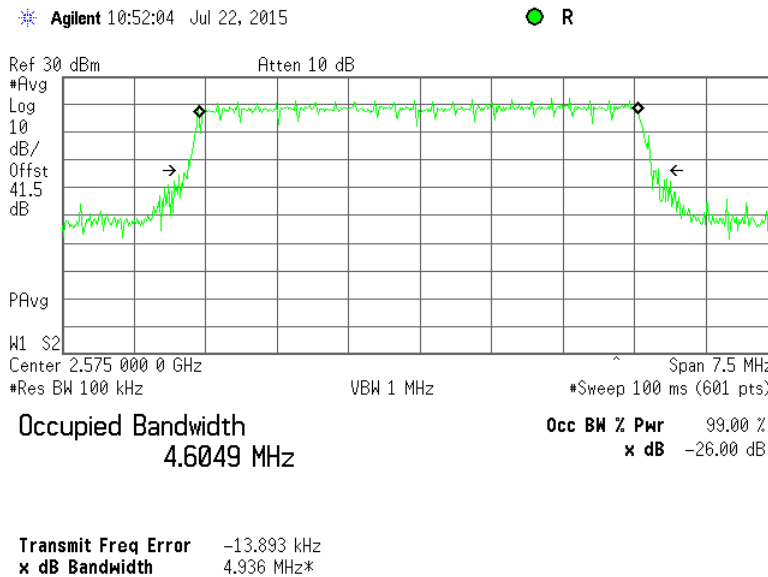



Test specification:		Section 2.1049, Occupied bandwidth	
Test procedure:		47 CFR, Section 2.1049	
Test mode:		Compliance	
Date(s):		22-Jul-15 - 23-Jul-15	
Temperature: 23 °C		Air Pressure: 1005 hPa	
Relative Humidity: 48 %		Power Supply: 48 VDC	
Remarks:			
		Verdict: PASS	

Plot 7.1.15 Occupied bandwidth test result at high frequency, 5 MHz BW, 64QAM (2687.5 MHz)

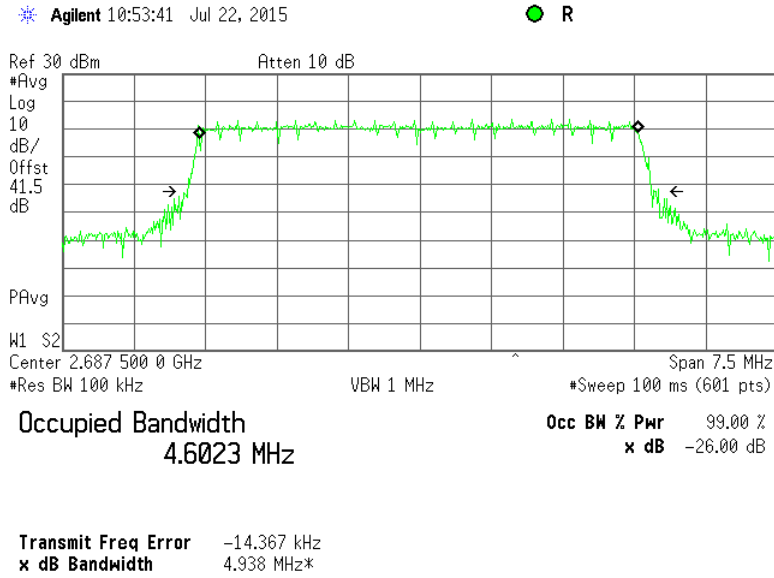

Plot 7.1.16 Occupied bandwidth test result at low frequency, 10 MHz BW, 64QAM (2501.0MHz)

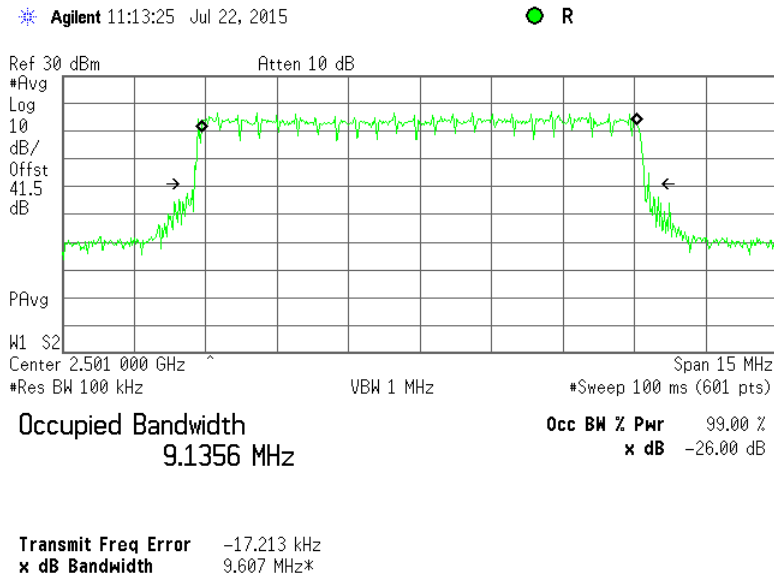



Test specification:		Section 2.1049, Occupied bandwidth	
Test procedure:		47 CFR, Section 2.1049	
Test mode:		Compliance	
Date(s):		22-Jul-15 - 23-Jul-15	
Temperature: 23 °C		Air Pressure: 1005 hPa	
Relative Humidity: 48 %		Power Supply: 48 VDC	
Remarks:			
		Verdict: PASS	

Plot 7.1.17 Occupied bandwidth test result at mid frequency, 10 MHz BW, 64QAM (2596.0 MHz)

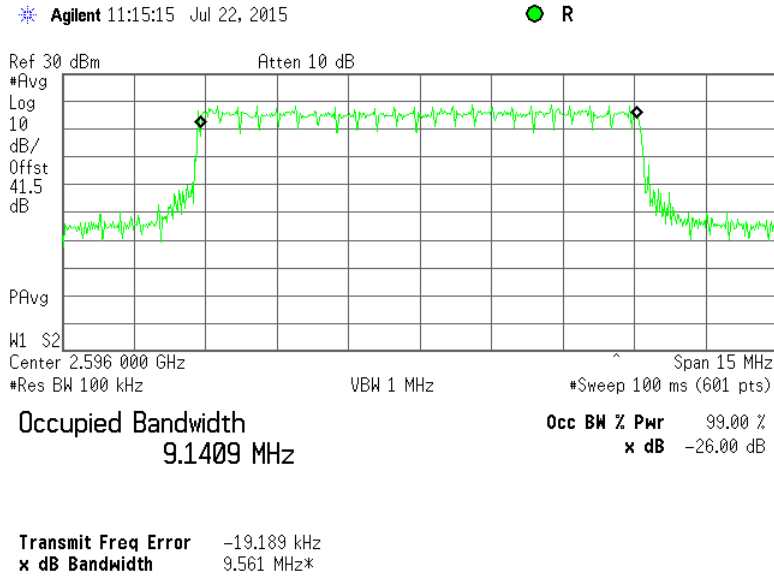

Plot 7.1.18 Occupied bandwidth test result at high frequency, 10 MHz BW, 64QAM (2685.0 MHz)

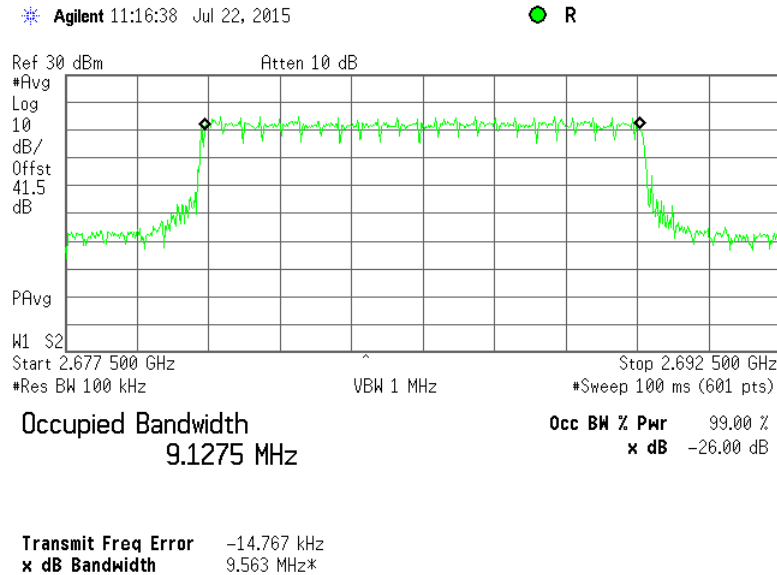



Test specification:		Section 27.50(h), Peak output power	
Test procedure:		47 CFR, Section 2.1046; TIA/EIA-603-D, Section 2.2.1	
Test mode:		Verdict: PASS	
Date(s):		23-Jul-15	
Temperature: 23 °C	Air Pressure: 1006 hPa	Relative Humidity: 48 %	Power Supply: 48 VDC
Remarks:			

7.2 Peak output power test

7.2.1 General

This test was performed to measure the peak output power at RF antenna connector. Specification test limits are given in Table 7.2.1.

Table 7.2.1 Peak output power limits

Transmitter type	Assigned frequency range, MHz	Maximum peak output power (EIRP), dBm
Main, booster and base stations	2496 – 2690	$63+10\log(X/Y)+10\log(360/\text{beamwidth})$
		Maximum peak power density, dBm/100 kHz
		$\text{EIRP}+10\log(0.1/Y)$

*- X is the actual channel width in MHz (occupied bandwidth), Y is channel bandwidth

- 1) 6 MHz if prior to transition or the station is in the MBS following transition or
- 2) 5.5 MHz if the station is in the LBS and UBS following transition, and
- 3) beamwidth is the total horizontal plane beam width of the individual transmitting antenna for the station or any sector measured at the half-power points.

7.2.2 Test procedure

- 7.2.2.1 The EUT was set up as shown in Figure 7.2.1, energized and its proper operation was checked.
- 7.2.2.2 The EUT was adjusted to produce maximum available to the end user RF output power.
- 7.2.2.3 The resolution bandwidth of spectrum analyzer was set about 1% of the emission bandwidth and the average power was integrated over EBW with spectrum analyzer as provided in Table 7.2.2, Table 7.2.3.
- 7.2.2.4 The resolution bandwidth was changed to 100 kHz and power spectral density was measured as provided in Table 7.2.4, Table 7.2.5.
- 7.2.2.5 The test results are provided in the tables below and the associated plots.

Figure 7.2.1 Peak output power test setup

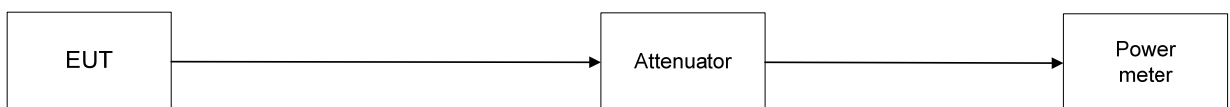



Test specification:		Section 27.50(h), Peak output power	
Test procedure:		47 CFR, Section 2.1046; TIA/EIA-603-D, Section 2.2.1	
Test mode:		Compliance	
Date(s):		23-Jul-15	
Temperature: 23 °C		Air Pressure: 1006 hPa	
		Relative Humidity: 48 %	
		Power Supply: 48 VDC	
Remarks:			

Table 7.2.2 Peak output power test results, 5 MHz RF channel BW

ASSIGNED FREQUENCY RANGE: 2496.0 – 2690.0 MHz
 DETECTOR USED: Average
 MODULATING SIGNAL: PRBS
 TRANSMITTER OUTPUT POWER SETTINGS: Maximum
 DUTY CYCLE: 100% with gating
 EBW: 5 MHz
 NUMBER OF RF OUTPUTS: N = 2 (uncorrelated)

- Carrier frequency, MHz	Power Meter reading RF#1, dBm	Power Meter reading RF#2, dBm	Total RF power**, dBm	Antenna gain, dBi	Total EIRP*, dBm	Limit***, dBm	Margin, dB	Verdict
QPSK 4.19 Mbps								
2498.5	28.07	29.20	31.68	18.0	49.70	69.54	-19.85	Pass
2575.0	35.66	34.57	38.16	18.0	56.16	69.54	-13.38	Pass
2687.5	27.21	27.21	30.22	18.0	48.24	69.92	-21.68	Pass
64QAM 18.85 Mbps								
2498.5	28.50	29.02	31.78	18.0	49.79	69.59	-19.80	Pass
2575.0	34.97	35.10	38.05	18.0	56.05	69.59	-13.54	Pass
2687.5	27.21	27.10	30.17	18.0	48.18	69.97	-21.79	Pass

* - EIRP total, dBm = Total RF power**, dBm + Antenna Gain, dBi
 ** - Total RF power, dBm = 10 log{10^[P(dBm,RF#1)/10]+ 10^[P(dBm, RF#2)/10]}
 *** - See Table 7.2.6
 Margin, dB = Total EIRP, dBm – Limit, dBm

Table 7.2.3 Peak output power test results, 10 MHz RF channel BW

ASSIGNED FREQUENCY RANGE: 2496.0 – 2690.0 MHz
 DETECTOR USED: Average
 MODULATING SIGNAL: PRBS
 TRANSMITTER OUTPUT POWER SETTINGS: Maximum
 DUTY CYCLE: 100% with gating
 EBW: 10 MHz
 NUMBER OF RF OUTPUTS: N = 2 (uncorrelated)

- Carrier frequency, MHz	Power Meter reading RF#1, dBm	Power Meter reading RF#2, dBm	Total RF power**, dBm	Antenna gain, dBi	Total EIRP*, dBm	Limit***, dBm	Margin, dB	Verdict
QPSK 8.38 Mbps								
2501.0	31.31	32.37	34.88	18.0	52.90	69.63	-16.73	Pass
2596.0	32.61	35.66	37.41	18.0	55.41	69.45	-14.04	Pass
2685.0	30.93	31.96	34.49	18.0	52.50	69.83	-17.33	Pass
64QAM 37.7 Mbps								
2501.0	31.23	33.23	35.35	18.0	53.37	69.65	-16.28	Pass
2596.0	34.30	35.40	37.90	18.0	55.90	69.45	-13.55	Pass
2685.0	31.25	31.75	34.52	18.0	52.53	69.83	-17.30	Pass

* - EIRP total, dBm = Total RF power**, dBm + Antenna Gain, dBi
 ** - Total RF power, dBm = 10 log{10^[P(dBm,RF#1)/10]+ 10^[P(dBm, RF#2)/10]}
 *** - See Table 7.2.6
 Margin, dB = Total EIRP, dBm – Limit, dBm

Reference numbers of test equipment used

HL 3301	HL 3302	HL 3667	HL 3818	HL 4293			
---------	---------	---------	---------	---------	--	--	--

Full description is given in Appendix A.



Test specification:		Section 27.50(h), Peak output power	
Test procedure:		47 CFR, Section 2.1046; TIA/EIA-603-D, Section 2.2.1	
Test mode:		Compliance	
Date(s):		23-Jul-15	
Temperature: 23 °C		Air Pressure: 1006 hPa	
		Relative Humidity: 48 %	
		Power Supply: 48 VDC	
Remarks:			
Verdict: PASS			

Table 7.2.4 Peak output power spectral density test results for 5 MHz RF channel BW

OPERATING FREQUENCY RANGE: 2496.0 – 2690.0 MHz
 DETECTOR USED: Average
 RESOLUTION BANDWIDTH: 100 kHz
 VIDEO BANDWIDTH: 50 MHz
 MODULATING SIGNAL: PRBS
 MAXIMUM DEDICATED ANTENNA GAIN: 18 dBi 90° Half-power beamwidth (Hor)
 NUMBER OF RF OUTPUTS: N = 2 (uncorrelated)
 TRANSMITTER OUTPUT POWER SETTINGS: Low:54, Mid:54, High:54, IF:-25
 DUTY CYCLE: 100% with gating

MODULATION: QPSK
 BIT RATE: 4.19 Mbps

Carrier frequency, MHz	Spectrum analyzer reading, dBm/100kHz	Total PSD*, dBm/100kHz	Antenna gain, dBi	Power spectral density, dBm/100kHz**	Limit, dBm/100kHz	Margin, dB	Verdict
2498.5	13.51	16.52	18.0	34.52	51.76	-17.24	Pass
2575.0	18.61	21.62	18.0	39.62	51.76	-12.14	Pass
2687.5	12.17	15.18	18.0	33.18	52.52	-19.33	Pass

MODULATION: 64QAM
 BIT RATE: 18.85 Mbps

Carrier frequency, MHz	Spectrum analyzer reading, dBm/100kHz	Total PSD*, dBm/100kHz	Antenna gain, dBi	Power spectral density, dBm/100kHz**	Limit, dBm/100kHz	Margin, dB	Verdict
2498.5	13.56	16.57	18.0	34.59	51.81	-17.22	Pass
2575.0	19.68	22.69	18.0	40.69	51.80	-11.11	Pass
2687.5	11.64	14.65	18.0	32.67	52.56	-19.90	Pass

* - Total PSD, dBm/100kHz = Spectrum analyzer reading, dBm/100kHz + 10log(N), dB
 ** - Power spectral density (EIRP), dBm/100 kHz = Total PSD, dBm/100kHz + Antenna gain, dBi
 Margin, dB = Power spectral density (EIRP), dBm/100 kHz – Limit, dBm/100 kHz

Reference numbers of test equipment used

HL 3301	HL 3302	HL 3667	HL 3818	HL 4293		
---------	---------	---------	---------	---------	--	--

Full description is given in Appendix A.



Test specification:	Section 27.50(h), Peak output power		
Test procedure:	47 CFR, Section 2.1046; TIA/EIA-603-D, Section 2.2.1		
Test mode:	Compliance	Verdict:	PASS
Date(s):	23-Jul-15		
Temperature: 23 °C	Air Pressure: 1006 hPa	Relative Humidity: 48 %	Power Supply: 48 VDC
Remarks:			

Table 7.2.5 Peak output power spectral density test results for 10 MHz RF channel BW

OPERATING FREQUENCY RANGE: 2496.0 – 2690.0 MHz
DETECTOR USED: Average
RESOLUTION BANDWIDTH: 100 kHz
VIDEO BANDWIDTH: 50 MHz
MODULATING SIGNAL: PRBS
MAXIMUM DEDICATED ANTENNA GAIN: 18 dBi 90° Half-power beamwidth (Hor)
NUMBER OF RF OUTPUTS: N = 2 (uncorrelated)
TRANSMITTER OUTPUT POWER SETTINGS: Low:56
Mid:56
High:56
IF:-25
DUTY CYCLE: 100% with gating

MODULATION: QPSK
BIT RATE: 8.38 Mbps

Carrier frequency, MHz	Spectrum analyzer reading, dBm/100kHz	Total PSD*, dBm/100kHz	Antenna gain, dBi	Power spectral density, dBm/100kHz**	Limit, dBm/100kHz	Margin, dB	Verdict
2501.00	13.22	16.23	18.0	34.23	49.02	-14.79	Pass
2596.00	16.74	19.75	18.0	37.77	48.66	-10.89	Pass
2685.00	13.63	16.64	18.0	34.64	49.41	-14.77	Pass

MODULATION: 64QAM
BIT RATE: 18.85 Mbps

Carrier frequency, MHz	Spectrum analyzer reading, dBm/100kHz	Total PSD*, dBm/100kHz	Antenna gain, dBi	Power spectral density, dBm/100kHz**	Limit, dBm/100kHz	Margin, dB	Verdict
2501.00	14.49	17.50	18.0	35.52	49.05	-13.53	Pass
2596.00	16.14	19.15	18.0	37.15	48.66	-11.50	Pass
2685.00	12.34	15.35	18.0	33.37	49.41	-16.05	Pass

* - Total PSD, dBm/100kHz = Spectrum analyzer reading, dBm/100kHz + 10log(N), dB
** - Power spectral density (EIRP), dBm/100 kHz = Total PSD, dBm/100kHz + Antenna gain, dBi
Margin, dB = Power spectral density (EIRP), dBm/100 kHz – Limit, dBm/100 kHz

Reference numbers of test equipment used

HL 3301	HL 3302	HL 3667	HL 3818	HL 4293			
---------	---------	---------	---------	---------	--	--	--

Full description is given in Appendix A.



Test specification:		Section 27.50(h), Peak output power	
Test procedure:		47 CFR, Section 2.1046; TIA/EIA-603-D, Section 2.2.1	
Test mode:		Compliance	
Date(s):		23-Jul-15	
Temperature: 23 °C		Air Pressure: 1006 hPa	
		Relative Humidity: 48 %	
		Power Supply: 48 VDC	
Remarks:			
		Verdict: PASS	

Table 7.2.6 Post transition frequency channels assignment

Channel	Channel BW, MHz	Peak power limit, dBm	Power density limit, dBm/kHz
		18 dBi antenna gain	
5 MHz Single Channel			
2498.5 MHz: ERS Ch. A1	5.5	$63+10\log(\text{OBW}/5.5)+10\log(360^\circ/90^\circ)$	EIRP+10log(0.1/5.5)
2575.0 MHz: EBS Ch. D4	6.0	$63+10\log(\text{OBW}/6.0)+10\log(360^\circ/90^\circ)$	EIRP+10log(0.1/6.0)
2687.5 MHz: BRS Ch. G3	5.5	$63+10\log(\text{OBW}/5.5)+10\log(360^\circ/90^\circ)$	EIRP+10log(0.1/5.5)
10 MHz Dual Channel			
2501.0 MHz BRS Ch. 1+ EBS Ch. A1	11.5	$63+10\log(\text{OBW}/11.5)+10\log(360^\circ/90^\circ)$	EIRP+10log(0.1/11.5)
2596.0 MHz EBS Ch. D4 + EBS Ch. G4	12.0	$63+10\log(\text{OBW}/12.0)+10\log(360^\circ/90^\circ)$	EIRP+10log(0.1/12.0)
2685.0 MHz BRS Ch. G2 + BRS Ch. G3	11.0	$63+10\log(\text{OBW}/11.0)+10\log(360^\circ/90^\circ)$	EIRP+10log(0.1/11.0)

NOTE: Channels at post transition band were taken as the worst case



Test specification:		Section 27.50(h), Peak output power	
Test procedure:		47 CFR, Section 2.1046; TIA/EIA-603-D, Section 2.2.1	
Test mode:		Compliance	
Date(s):		23-Jul-15	
Temperature: 23 °C		Air Pressure: 1006 hPa	
		Relative Humidity: 48 %	
		Power Supply: 48 VDC	
Remarks:			
		Verdict: PASS	

Plot 7.2.1 Power spectral density test results at low frequency, QPSK, 5 MHz EBW, RF # 2

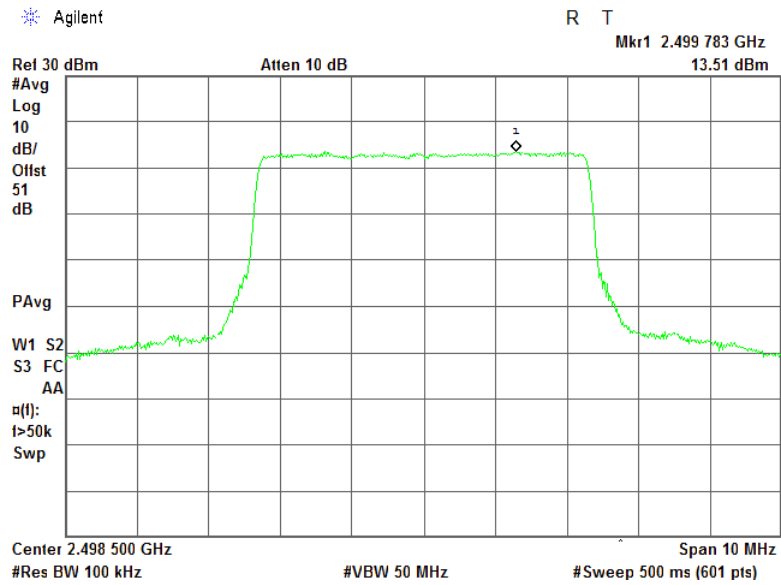

Plot 7.2.2 Power spectral density test results at mid frequency, QPSK, 5 MHz EBW, RF # 2

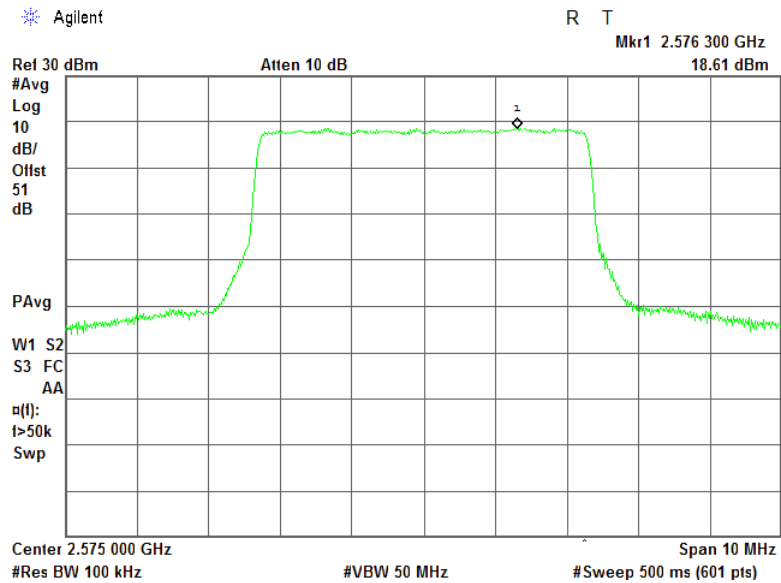



Test specification:		Section 27.50(h), Peak output power	
Test procedure:		47 CFR, Section 2.1046; TIA/EIA-603-D, Section 2.2.1	
Test mode:		Compliance	
Date(s):		23-Jul-15	
Temperature: 23 °C		Air Pressure: 1006 hPa	
		Relative Humidity: 48 %	
		Power Supply: 48 VDC	
Remarks:			
		Verdict: PASS	

Plot 7.2.3 Power spectral density test results at high frequency, QPSK, 5 MHz EBW, RF # 2

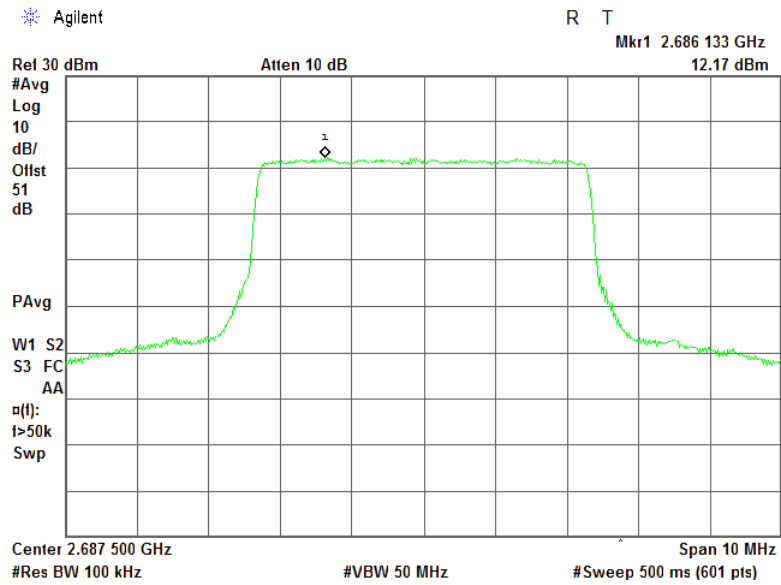

Plot 7.2.4 Power spectral density test results at low frequency, 64QAM, 5 MHz EBW, RF # 2

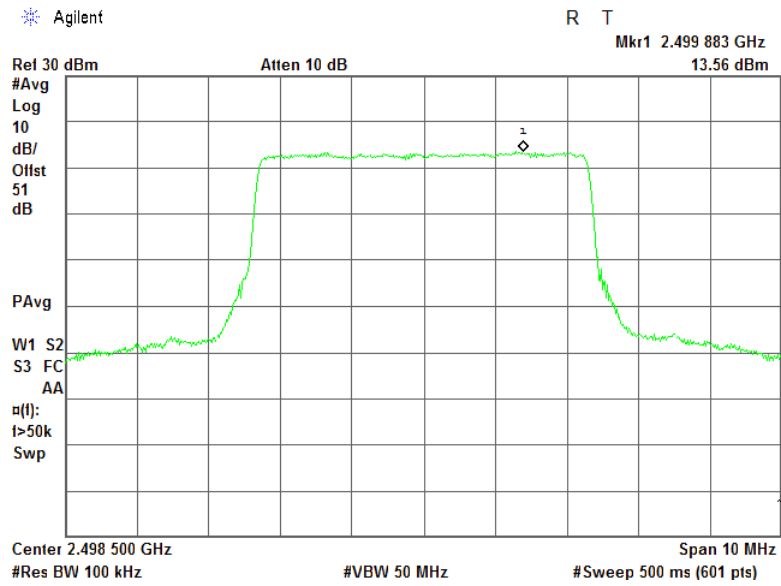



HERMON LABORATORIES

Test specification:		Section 27.50(h), Peak output power	
Test procedure:		47 CFR, Section 2.1046; TIA/EIA-603-D, Section 2.2.1	
Test mode:		Compliance	
Date(s):		23-Jul-15	
Temperature: 23 °C		Air Pressure: 1006 hPa	
		Relative Humidity: 48 %	
		Power Supply: 48 VDC	
Remarks:			
		Verdict: PASS	

Plot 7.2.5 Power spectral density test results at mid frequency, 64QAM, 5 MHz EBW, RF # 2

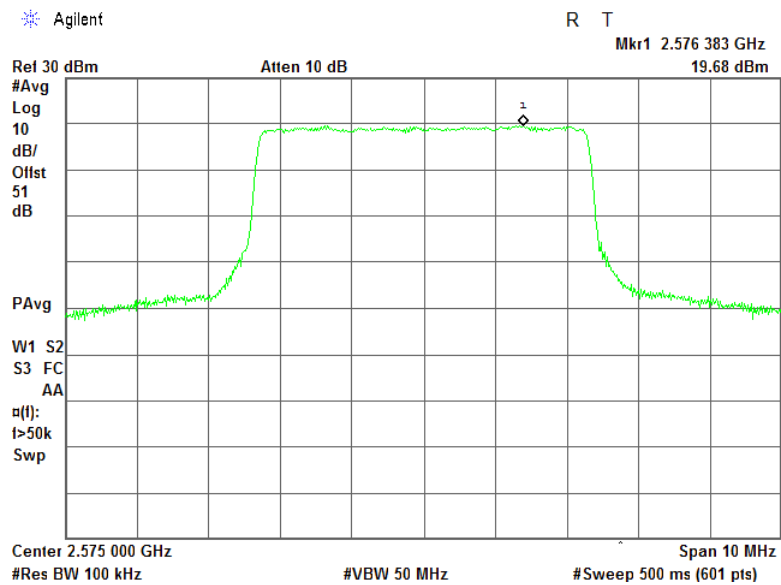

Plot 7.2.6 Power spectral density test results at high frequency, 64QAM, 5MHz EBW, RF # 2

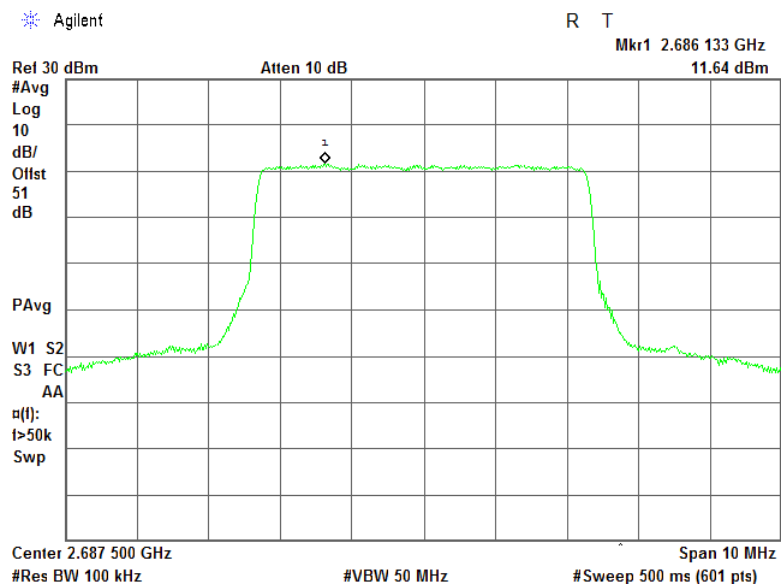



HERMON LABORATORIES

Test specification:		Section 27.50(h), Peak output power	
Test procedure:		47 CFR, Section 2.1046; TIA/EIA-603-D, Section 2.2.1	
Test mode:		Compliance	
Date(s):		23-Jul-15	
Temperature: 23 °C		Air Pressure: 1006 hPa	
		Relative Humidity: 48 %	
		Power Supply: 48 VDC	
Remarks:			
		Verdict: PASS	

Plot 7.2.7 Power spectral density test results at low frequency, QPSK, 10 MHz EBW, RF # 2

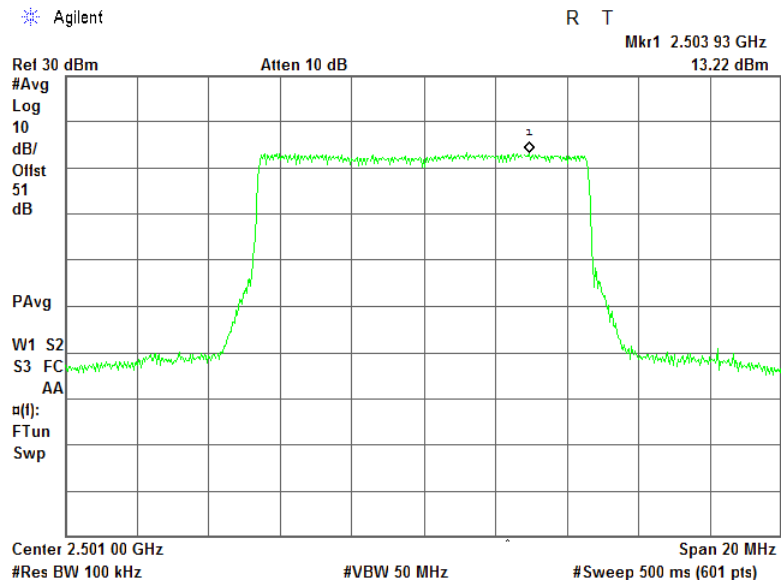

Plot 7.2.8 Power spectral density test results at mid frequency, QPSK, 10 MHz EBW, RF # 2

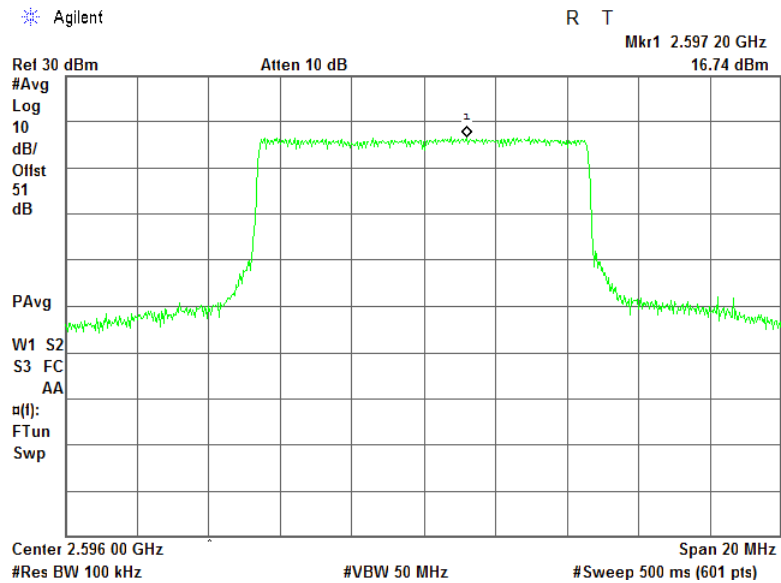



HERMON LABORATORIES

Test specification:		Section 27.50(h), Peak output power	
Test procedure:		47 CFR, Section 2.1046; TIA/EIA-603-D, Section 2.2.1	
Test mode:		Compliance	
Date(s):		23-Jul-15	
Temperature: 23 °C		Air Pressure: 1006 hPa	
		Relative Humidity: 48 %	
		Power Supply: 48 VDC	
Remarks:			
		Verdict: PASS	

Plot 7.2.9 Power spectral density test results at high frequency, QPSK, 10 MHz EBW, RF # 2

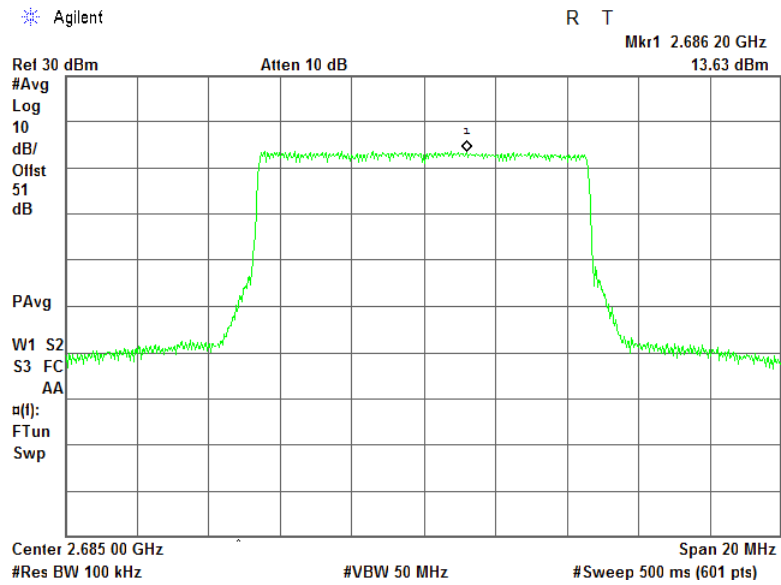

Plot 7.2.10 Power spectral density test results at low frequency, 64QAM, 10 MHz EBW, RF # 2

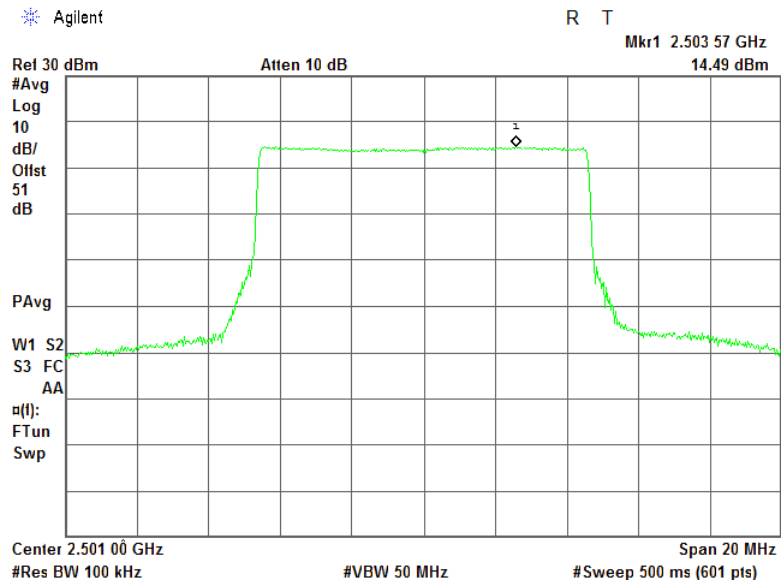



HERMON LABORATORIES

Test specification:		Section 27.50(h), Peak output power	
Test procedure:		47 CFR, Section 2.1046; TIA/EIA-603-D, Section 2.2.1	
Test mode:		Compliance	
Date(s):		23-Jul-15	
Temperature: 23 °C		Air Pressure: 1006 hPa	
		Relative Humidity: 48 %	
		Power Supply: 48 VDC	
Remarks:			
		Verdict: PASS	

Plot 7.2.11 Power spectral density test results at mid frequency, 64QAM, 10 MHz EBW, RF # 2

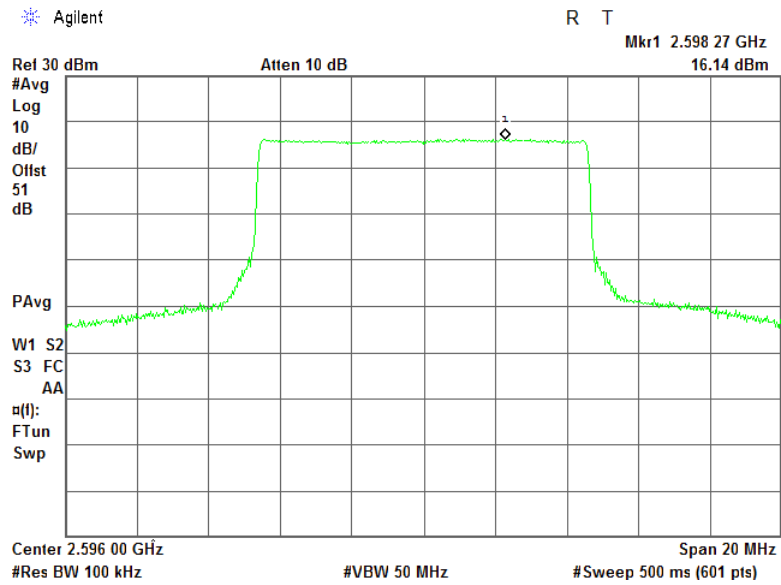

Plot 7.2.12 Power spectral density test results at high frequency, 64QAM, 10 MHz EBW, RF # 2

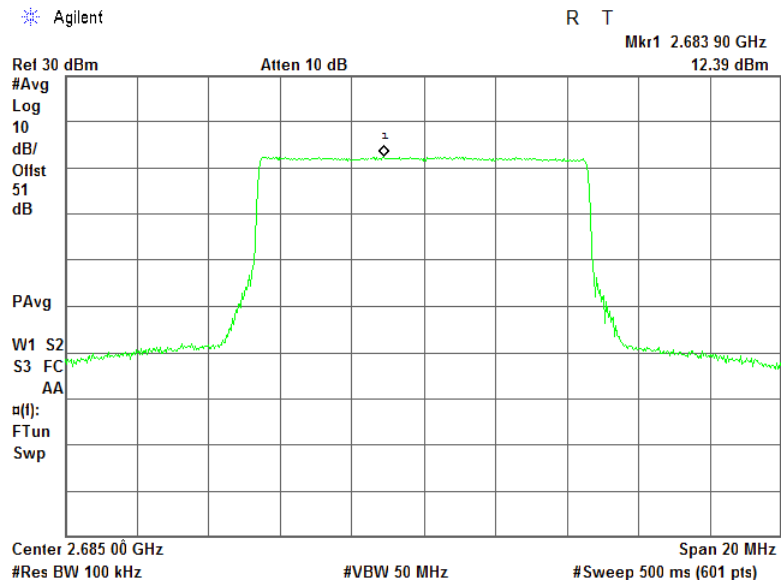



Test specification:		Section 27.53(m)(2), Band edge emissions	
Test procedure:		47 CFR, Sections 2.1051, 27.53; TIA/EIA-603-D, Section 2.2.13	
Test mode:		Verdict: PASS	
Date(s):		20-Jul-15 - 22-Jul-15	
Temperature: 23 °C	Air Pressure: 1005 hPa	Relative Humidity: 48 %	Power Supply: 48 VDC
Remarks:			

7.3 Band edge emissions at RF connector test

7.3.1 General

This test was performed to measure spurious emissions at the channel edge at the RF antenna connector. Specification test limits are given in Table 7.3.1.

Table 7.3.1 Spurious emission limits at band edges

Channel, MHz	Frequency range, MHz	Attenuation below carrier, dBc
Channel bandwidth 5 MHz		
2498.50	2490.0 – 2496.0 & 2501.0 – 2507.0	43 + 10*Log (P*)
2575.00	2584.5 - 2590.5 & 2595.5 – 2601.5	43 + 10*Log (P*)
2687.50	2679.0 – 2685.0 & 2690.0 – 2696.0	43 + 10*Log (P*)
Channel bandwidth 10 MHz		
2501.00	2490.0 – 2496.0 & 2506.0 – 2512.0	43 + 10*Log (P*)
2596.00	2582.0 – 2588.0 & 2598.0 – 2604.0	43 + 10*Log (P*)
2685.00	2674.0 – 2680.0 & 2690.0 – 2696.0	43 + 10*Log (P*)

* - P is transmitter output power in Watts

7.3.2 Test procedure

7.3.2.1 The EUT was set up as shown in Figure 7.3.1, energized and its proper operation was checked.

7.3.2.2 The spurious emission was measured with spectrum analyzer as provided in the associated tables and plots.

Figure 7.3.1 Spurious emission test setup for single output

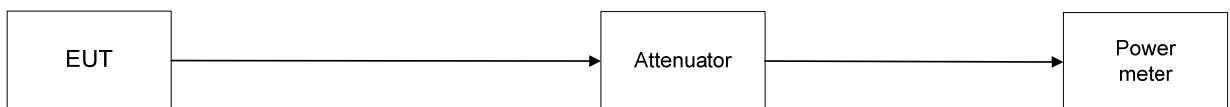



Test specification:		Section 27.53(m)(2), Band edge emissions	
Test procedure:		47 CFR, Sections 2.1051, 27.53; TIA/EIA-603-D, Section 2.2.13	
Test mode:		Compliance	
Date(s):		20-Jul-15 - 22-Jul-15	
Temperature: 23 °C		Air Pressure: 1005 hPa	
		Relative Humidity: 48 %	
		Power Supply: 48 VDC	
Remarks:			
Verdict: PASS			

Table 7.3.2 Spurious emission at band edges test results

ASSIGNED FREQUENCY RANGE: 2496.0 – 2690.0 MHz
 INVESTIGATED FREQUENCY RANGE: See below
 RBW: 100 kHz
 DETECTOR USED: Average
 VIDEO BANDWIDTH: ≥ Resolution bandwidth
 MODULATING SIGNAL: PRBS
 TRANSMITTER OUTPUT POWER SETTINGS: Maximum
 MODULATION: QPSK
 EBW: 5 MHz
 NUMBER OF RF OUTPUTS: N = 2 (uncorrelated)

Frequency offset, ± MHz	Low band edge SA reading, dBm	Low band edge result, dBm	RBW, kHz	Integration BW, kHz	Limit, dBm	Verdict
Transceiver Output power 29.2 dBm						
Low carrier frequency 2498.5 MHz						
-3.0	-14.10	-14.10	100	1000	-13.0	Pass
-4.0	-25.03	-25.03	100	1000	-13.0	
4.0	-25.31	-25.31	100	1000	-13.0	
5.0	-28.15	-28.15	100	1000	-13.0	
Transceiver Output power 34.57 dBm						
Mid carrier frequency 2575 MHz						
-3.5	-15.15	-15.15	100	1000	-13.0	Pass
-4.5	-17.05	-17.05	100	1000	-13.0	
3.5	-14.72	-14.72	100	1000	-13.0	
4.5	-17.83	-17.83	100	1000	-13.0	
Transceiver Output power 27.21 dBm						
High carrier frequency 2687.5 MHz						
-4.0	-18.80	-18.80	100	1000	-13.0	Pass
-5.0	-21.99	-21.99	100	1000	-13.0	
3.0	-13.07	-13.07	100	1000	-13.0	
4.0	-19.87	-19.87	100	1000	-13.0	



Test specification:		Section 27.53(m)(2), Band edge emissions	
Test procedure:		47 CFR, Sections 2.1051, 27.53; TIA/EIA-603-D, Section 2.2.13	
Test mode:		Compliance	
Date(s):		20-Jul-15 - 22-Jul-15	
Temperature: 23 °C		Air Pressure: 1005 hPa	
		Relative Humidity: 48 %	
		Power Supply: 48 VDC	
Remarks:			

Table 7.3.2 Spurious emission at band edges test results (continued)

ASSIGNED FREQUENCY RANGE: 2496.0 – 2690.0 MHz
 INVESTIGATED FREQUENCY RANGE: See below
 RBW: 100 kHz
 DETECTOR USED: Average
 VIDEO BANDWIDTH: ≥ Resolution bandwidth
 MODULATING SIGNAL: PRBS
 TRANSMITTER OUTPUT POWER SETTINGS: Maximum
 MODULATION: QPSK
 EBW: 10 MHz
 NUMBER OF RF OUTPUTS: N = 2 (uncorellated)

Frequency offset, ± MHz	Band edge SA reading, dBm	Band edge result, dBm	RBW, kHz	Integration BW, kHz	Limit, dBm	Verdict
Transceiver Output power 32.37 dBm						
Low carrier frequency 2501.0 MHz						
-5.5	-13.81	-13.81	100	1000	-13.0	Pass
-6.5	-21.73	-21.73	100	1000	-13.0	
6.5	-20.85	-20.85	100	1000	-13.0	
7.5	-22.34	-22.34	100	1000	-13.0	
Transceiver Output power 35.66 dBm						
Mid carrier frequency 2596.0 MHz						
-6.5	-13.91	-13.91	100	1000	-13.0	Pass
-7.5	-15.66	-15.66	100	1000	-13.0	
6.5	-14.91	-14.91	100	1000	-13.0	
7.5	-15.28	-15.28	100	1000	-13.0	
Transceiver Output power 31.96 dBm						
High carrier frequency 2685.0 MHz						
-6.5	-18.65	-18.65	100	1000	-13.0	Pass
-7.5	-19.63	-19.63	100	1000	-13.0	
5.5	-14.35	-14.35	100	1000	-13.0	
6.5	-18.98	-18.98	100	1000	-13.0	



Test specification:		Section 27.53(m)(2), Band edge emissions	
Test procedure:		47 CFR, Sections 2.1051, 27.53; TIA/EIA-603-D, Section 2.2.13	
Test mode:		Compliance	
Date(s):		20-Jul-15 - 22-Jul-15	
Temperature: 23 °C		Air Pressure: 1005 hPa	
Remarks:		Relative Humidity: 48 %	
		Power Supply: 48 VDC	
Verdict: PASS			

Table 7.3.3 Spurious emission at band edges test results

ASSIGNED FREQUENCY RANGE: 2496.0 – 2690.0 MHz
 INVESTIGATED FREQUENCY RANGE: See below
 RBW: 100 kHz
 DETECTOR USED: Average
 VIDEO BANDWIDTH: ≥ Resolution bandwidth
 MODULATING SIGNAL: PRBS
 TRANSMITTER OUTPUT POWER SETTINGS: Maximum
 MODULATION: 16QAM
 EBW: 5 MHz
 NUMBER OF RF OUTPUTS: N = 2 (uncorellated)

Frequency offset, ± MHz	Band edge SA reading, dBm	Band edge result, dBm	RBW, kHz	Integration BW, kHz	Limit, dBm	Verdict
Transceiver Output power 29.11 dBm						
Low carrier frequency 2498.5 MHz						
-3.0	-14.56	-14.56	100	1000	-13.0	Pass
-4.0	-24.75	-24.75	100	1000	-13.0	
4.0	-25.45	-25.45	100	1000	-13.0	
5.0	-28.07	-28.07	100	1000	-13.0	
Transceiver Output power 35.19 dBm						
Mid carrier frequency 2575 MHz						
-3.5	-13.99	-13.99	100	1000	-13.0	Pass
-4.5	-15.86	-15.86	100	1000	-13.0	
3.5	-13.43	-13.43	100	1000	-13.0	
4.5	-15.72	-15.72	100	1000	-13.0	
Transceiver Output power 27.18 dBm						
High carrier frequency 2687.5 MHz						
-4.0	-19.50	-19.50	100	1000	-13.0	Pass
-5.0	-23.08	-23.08	100	1000	-13.0	
3.0	-13.49	-13.49	100	1000	-13.0	
4.0	-20.04	-20.04	100	1000	-13.0	



Test specification:		Section 27.53(m)(2), Band edge emissions	
Test procedure:		47 CFR, Sections 2.1051, 27.53; TIA/EIA-603-D, Section 2.2.13	
Test mode:		Compliance	
Date(s):		20-Jul-15 - 22-Jul-15	
Temperature: 23 °C		Air Pressure: 1005 hPa	
		Relative Humidity: 48 %	
		Power Supply: 48 VDC	
Remarks:			

Table 7.3.3 Spurious emission at band edges test results (continued)

ASSIGNED FREQUENCY RANGE: 2496.0 – 2690.0 MHz
 INVESTIGATED FREQUENCY RANGE: See below
 RBW: 100 kHz
 DETECTOR USED: Average
 VIDEO BANDWIDTH: ≥ Resolution bandwidth
 MODULATING SIGNAL: PRBS
 TRANSMITTER OUTPUT POWER SETTINGS: Maximum
 MODULATION: 16QAM
 EBW: 10 MHz
 NUMBER OF RF OUTPUTS: N = 2 (uncorellated)

Frequency offset, ± MHz	Band edge SA reading, dBm	Band edge result, dBm	RBW, kHz	Integration BW, kHz	Limit, dBm	Verdict
Transceiver Output power 33.34 dBm						
Low carrier frequency 2501.0 MHz						
-5.5	-13.22	-13.22	100	1000	-13.0	Pass
-6.5	-20.44	-20.44	100	1000	-13.0	
6.5	-21.69	-21.69	100	1000	-13.0	
7.5	-22.26	-22.26	100	1000	-13.0	
Transceiver Output power 35.56 dBm						
Mid carrier frequency 2596.0 MHz						
-6.5	-14.13	-14.13	100	1000	-13.0	Pass
-7.5	-16.09	-16.09	100	1000	-13.0	
6.5	-15.55	-15.55	100	1000	-13.0	
7.5	-16.35	-16.35	100	1000	-13.0	
Transceiver Output power 31.86 dBm						
High carrier frequency 2685.0 MHz						
-6.5	-18.15	-18.15	100	1000	-13.0	Pass
-7.5	-19.67	-19.67	100	1000	-13.0	
5.5	-15.16	-15.16	100	1000	-13.0	
6.5	-20.32	-20.32	100	1000	-13.0	



Test specification:		Section 27.53(m)(2), Band edge emissions	
Test procedure:		47 CFR, Sections 2.1051, 27.53; TIA/EIA-603-D, Section 2.2.13	
Test mode:		Compliance	
Date(s):		20-Jul-15 - 22-Jul-15	
Temperature: 23 °C		Air Pressure: 1005 hPa	
		Relative Humidity: 48 %	
		Power Supply: 48 VDC	
Remarks:			

Table 7.3.4 Spurious emission at band edges test results

ASSIGNED FREQUENCY RANGE: 2496.0 – 2690.0 MHz
 INVESTIGATED FREQUENCY RANGE: See below
 RBW: 100 kHz
 DETECTOR USED: Average
 VIDEO BANDWIDTH: ≥ Resolution bandwidth
 MODULATING SIGNAL: PRBS
 TRANSMITTER OUTPUT POWER SETTINGS: Maximum
 MODULATION: 64QAM
 EBW: 5 MHz
 NUMBER OF RF OUTPUTS: N = 2 (uncorellated)

Frequency offset, ± MHz	Band edge SA reading, dBm	Band edge result, dBm	RBW, kHz	Integration BW, kHz	Limit, dBm	Verdict
Transceiver Output power 29.02 dBm						
Low carrier frequency 2498.5 MHz						
-3.0	-14.11	-14.11	100	1000	-13.0	Pass
-4.0	-25.09	-25.09	100	1000	-13.0	
4.0	-25.79	-25.79	100	1000	-13.0	
5.0	-28.40	-28.40	100	1000	-13.0	
Transceiver Output power 35.1 dBm						
Mid carrier frequency 2575 MHz						
-3.5	-14.63	-14.63	100	1000	-13.0	Pass
-4.5	-16.26	-16.26	100	1000	-13.0	
3.5	-13.84	-13.84	100	1000	-13.0	
4.5	-16.16	-16.16	100	1000	-13.0	
Transceiver Output power 27.1 dBm						
High carrier frequency 2501.0 MHz						
-4.0	-20.06	-20.06	100	1000	-13.0	Pass
-5.0	-23.39	-23.39	100	1000	-13.0	
3.0	-13.72	-13.72	100	1000	-13.0	
4.0	-20.09	-20.09	100	1000	-13.0	



Test specification:		Section 27.53(m)(2), Band edge emissions	
Test procedure:		47 CFR, Sections 2.1051, 27.53; TIA/EIA-603-D, Section 2.2.13	
Test mode:		Compliance	
Date(s):		20-Jul-15 - 22-Jul-15	
Temperature: 23 °C		Air Pressure: 1005 hPa	
		Relative Humidity: 48 %	
		Power Supply: 48 VDC	
Remarks:			
Verdict: PASS			

Table 7.3.4 Spurious emission at band edges test results (continued)

ASSIGNED FREQUENCY RANGE: 2496.0 – 2690.0 MHz
 INVESTIGATED FREQUENCY RANGE: See below
 RBW: 100 kHz
 DETECTOR USED: Average
 VIDEO BANDWIDTH: ≥ Resolution bandwidth
 MODULATING SIGNAL: PRBS
 TRANSMITTER OUTPUT POWER SETTINGS: Maximum
 MODULATION: 64QAM
 EBW: 10 MHz
 NUMBER OF RF OUTPUTS: N = 2 (uncorellated)

Frequency offset, ± MHz	Band edge SA reading, dBm	Band edge result, dBm	RBW, kHz	Integration BW, kHz	Limit, dBm	Verdict
Transceiver Output power 33.23 dBm						
Low carrier frequency 2501.0 MHz						
-5.5	-13.32	-13.32	100	1000	-13.0	Pass
-6.5	-20.67	-20.67	100	1000	-13.0	
6.5	-21.22	-21.22	100	1000	-13.0	
7.5	-22.27	-22.27	100	1000	-13.0	
Transceiver Output power 35.4 dBm						
Mid carrier frequency 2596.0 MHz						
-6.5	-14.17	-14.17	100	1000	-13.0	Pass
-7.5	-15.98	-15.98	100	1000	-13.0	
6.5	-15.31	-15.31	100	1000	-13.0	
7.5	-16.20	-16.20	100	1000	-13.0	
Transceiver Output power 31.75 dBm						
High carrier frequency 2685.0 MHz						
-6.5	-18.93	-18.93	100	1000	-13.0	Pass
-7.5	-19.71	-19.71	100	1000	-13.0	
5.5	-15.27	-15.27	100	1000	-13.0	
6.5	-19.20	-19.20	100	1000	-13.0	

Reference numbers of test equipment used

HL 3301	HL 3302	HL 3667	HL 3818	HL 4293		
---------	---------	---------	---------	---------	--	--

Full description is given in Appendix A.



HERMON LABORATORIES

Test specification:		Section 27.53(m)(2), Band edge emissions	
Test procedure:		47 CFR, Sections 2.1051, 27.53; TIA/EIA-603-D, Section 2.2.13	
Test mode:		Compliance	
Date(s):		20-Jul-15 - 22-Jul-15	
Temperature: 23 °C		Air Pressure: 1005 hPa	
Relative Humidity: 48 %		Power Supply: 48 VDC	
Remarks:			
		Verdict: PASS	

Plot 7.3.1 Spurious emission at band edges test results at low carrier frequency, 5 MHz EBW

FREQUENCY: 2498.5 MHz
DETECTOR USED: Average
MODULATION: QPSK
MODULATING SIGNAL: PRBS
TRANSMITTER OUTPUT POWER SETTINGS: 29.2 dBm

Agilent 08:42:49 Jul 22, 2015

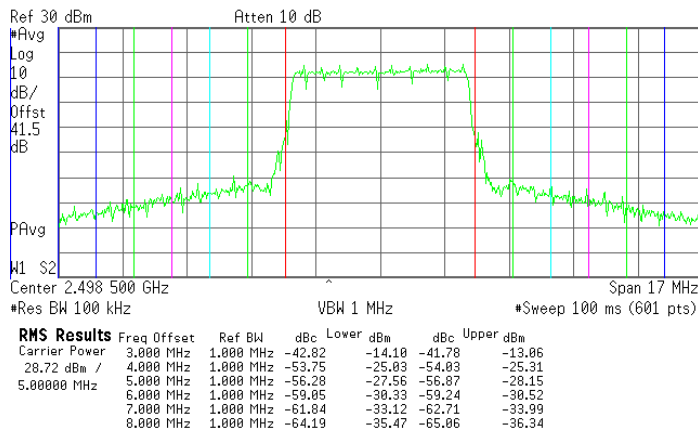

Plot 7.3.2 Spurious emission at band edges test results at mid carrier frequency, 5 MHz EBW

FREQUENCY: 2575.0 MHz
DETECTOR USED: Average
MODULATION: QPSK
MODULATING SIGNAL: PRBS
TRANSMITTER OUTPUT POWER SETTINGS: 34.57 dBm

Agilent 09:14:48 Jul 22, 2015

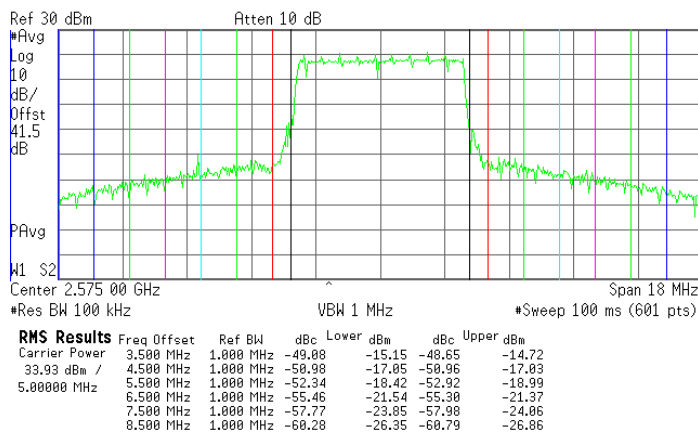



HERMON LABORATORIES

Test specification:	Section 27.53(m)(2), Band edge emissions		
Test procedure:	47 CFR, Sections 2.1051, 27.53; TIA/EIA-603-D, Section 2.2.13		
Test mode:	Compliance	Verdict:	PASS
Date(s):	20-Jul-15 - 22-Jul-15		
Temperature: 23 °C	Air Pressure: 1005 hPa	Relative Humidity: 48 %	Power Supply: 48 VDC
Remarks:			

Plot 7.3.3 Spurious emission at band edges test results at high carrier frequency, 5 MHz EBW

FREQUENCY: 2687.5 MHz
DETECTOR USED: Average
MODULATION: QPSK
MODULATING SIGNAL: PRBS
TRANSMITTER OUTPUT POWER SETTINGS: 27.21 dBm

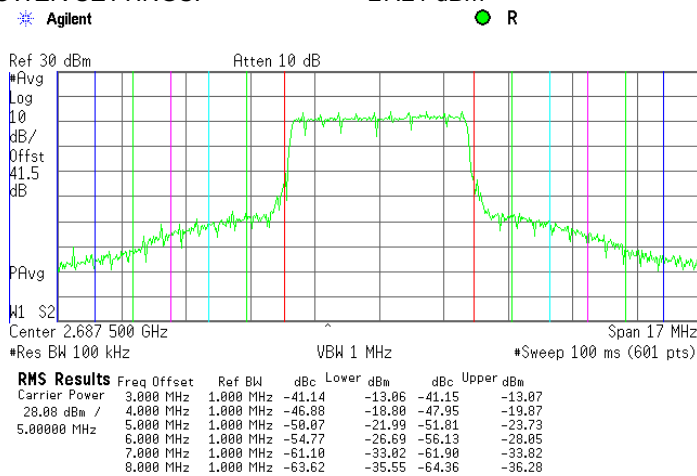

Plot 7.3.4 Spurious emission at band edges test results at low carrier frequency, 10 MHz EBW

FREQUENCY: 2501 MHz
DETECTOR USED: Average
MODULATION: QPSK
MODULATING SIGNAL: PRBS
TRANSMITTER OUTPUT POWER SETTINGS: 32.37 dBm

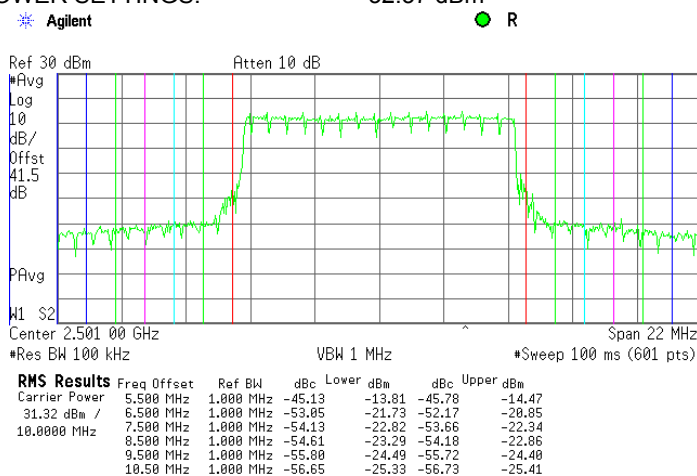



HERMON LABORATORIES

Test specification:		Section 27.53(m)(2), Band edge emissions	
Test procedure:		47 CFR, Sections 2.1051, 27.53; TIA/EIA-603-D, Section 2.2.13	
Test mode:		Compliance	
Date(s):		20-Jul-15 - 22-Jul-15	
Temperature: 23 °C		Air Pressure: 1005 hPa	
Relative Humidity: 48 %		Power Supply: 48 VDC	
Remarks:			
		Verdict: PASS	

Plot 7.3.5 Spurious emission at band edges test results at mid carrier frequency, 10 MHz EBW

FREQUENCY: 2596 MHz
DETECTOR USED: Average
MODULATION: QPSK
MODULATING SIGNAL: PRBS
TRANSMITTER OUTPUT POWER SETTINGS: 35.66

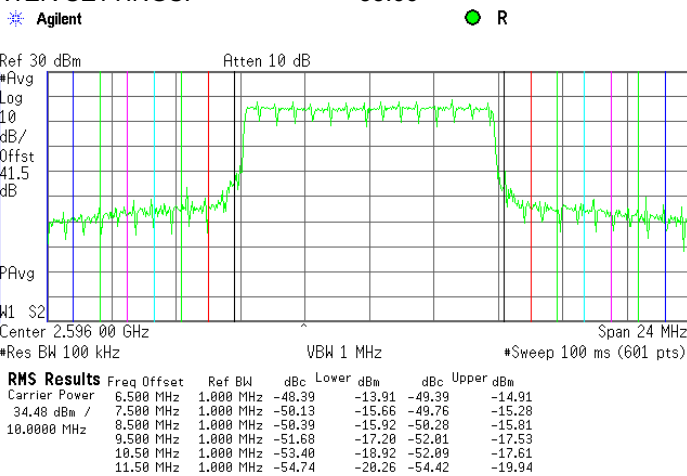

Plot 7.3.6 Spurious emission at band edges test results at high carrier frequency, 10 MHz EBW

FREQUENCY: 2685 MHz
DETECTOR USED: Average
MODULATION: QPSK
MODULATING SIGNAL: PRBS
TRANSMITTER OUTPUT POWER SETTINGS: 31.96 dBm

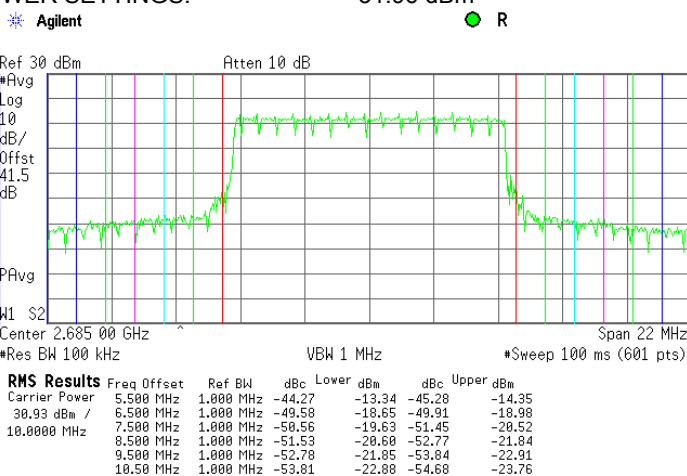



HERMON LABORATORIES

Test specification:	Section 27.53(m)(2), Band edge emissions		
Test procedure:	47 CFR, Sections 2.1051, 27.53; TIA/EIA-603-D, Section 2.2.13		
Test mode:	Compliance	Verdict:	PASS
Date(s):	20-Jul-15 - 22-Jul-15		
Temperature: 23 °C	Air Pressure: 1005 hPa	Relative Humidity: 48 %	Power Supply: 48 VDC
Remarks:			

Plot 7.3.7 Spurious emission at band edges test results at low carrier frequency, 5 MHz EBW

FREQUENCY: 2498.5MHz
DETECTOR USED: Average
MODULATION: 16QAM
MODULATING SIGNAL: PRBS
TRANSMITTER OUTPUT POWER SETTINGS: 29.11 dBm

Agilent 08:50:54 Jul 22, 2015

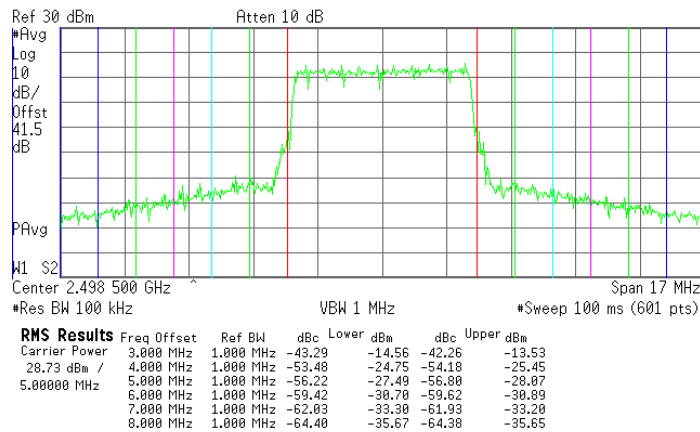

Plot 7.3.8 Spurious emission at band edges test results at mid carrier frequency, 5 MHz EBW

FREQUENCY: 2575 MHz
DETECTOR USED: Average
MODULATION: 16QAM
MODULATING SIGNAL: PRBS
TRANSMITTER OUTPUT POWER SETTINGS: 35.19 dBm

Agilent 09:19:49 Jul 22, 2015

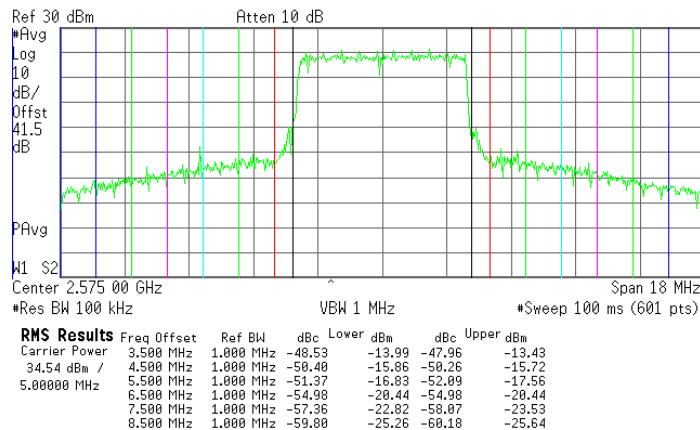



HERMON LABORATORIES

Test specification:		Section 27.53(m)(2), Band edge emissions	
Test procedure:		47 CFR, Sections 2.1051, 27.53; TIA/EIA-603-D, Section 2.2.13	
Test mode:		Compliance	
Date(s):		20-Jul-15 - 22-Jul-15	
Temperature: 23 °C		Air Pressure: 1005 hPa	
Relative Humidity: 48 %		Power Supply: 48 VDC	
Remarks:			
		Verdict: PASS	

Plot 7.3.9 Spurious emission at band edges test results at high carrier frequency, 5 MHz EBW

FREQUENCY: 2687.5 MHz
 DETECTOR USED: Average
 MODULATION: 16QAM
 MODULATING SIGNAL: PRBS
 TRANSMITTER OUTPUT POWER SETTINGS: 27.18 dBm

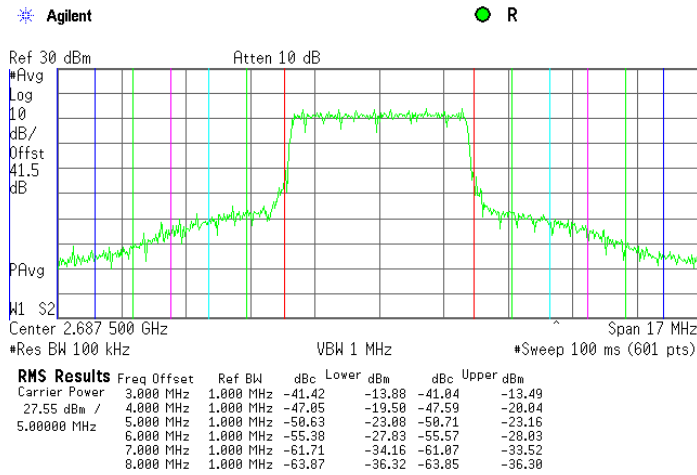

Plot 7.3.10 Spurious emission at band edges test results at low carrier frequency, 10 MHz EBW

FREQUENCY: 2501 MHz
 DETECTOR USED: Average
 MODULATION: 16QAM
 MODULATING SIGNAL: PRBS
 TRANSMITTER OUTPUT POWER SETTINGS: 33.34 dBm

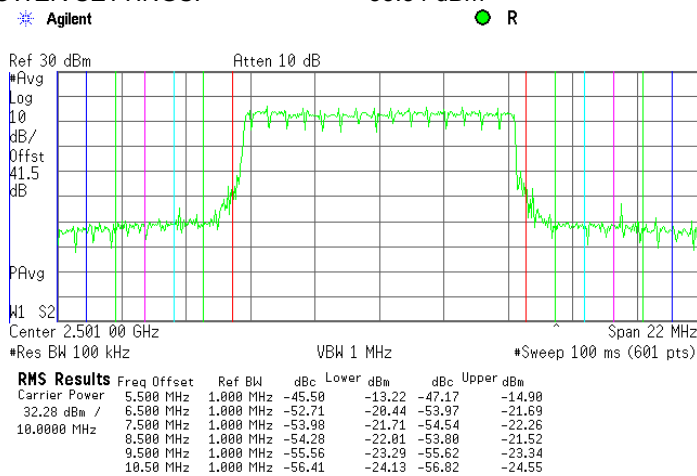



HERMON LABORATORIES

Test specification:		Section 27.53(m)(2), Band edge emissions	
Test procedure:		47 CFR, Sections 2.1051, 27.53; TIA/EIA-603-D, Section 2.2.13	
Test mode:		Compliance	
Date(s):		20-Jul-15 - 22-Jul-15	
Temperature: 23 °C		Air Pressure: 1005 hPa	
Relative Humidity: 48 %		Power Supply: 48 VDC	
Remarks:			
		Verdict: PASS	

Plot 7.3.11 Spurious emission at band edges test results at mid carrier frequency, 10 MHz EBW

FREQUENCY: 2596 MHz
DETECTOR USED: Average
MODULATION: 16QAM
MODULATING SIGNAL: PRBS
TRANSMITTER OUTPUT POWER SETTINGS: 35.56 dBm

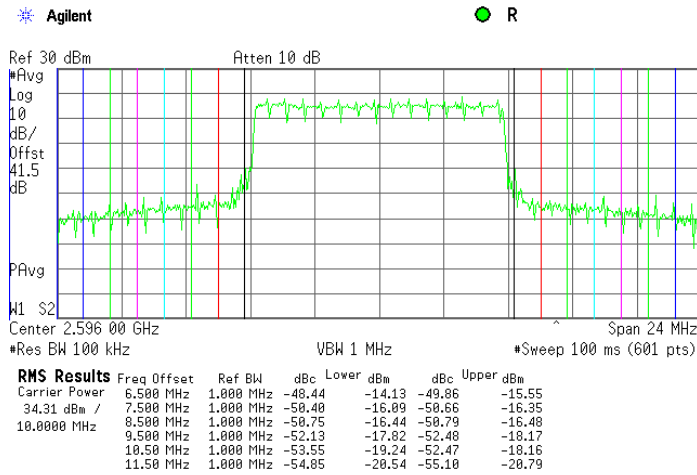

Plot 7.3.12 Spurious emission at band edges test results at high carrier frequency, 10 MHz EBW

FREQUENCY: 2685 MHz
DETECTOR USED: Average
MODULATION: 16QAM
MODULATING SIGNAL: PRBS
TRANSMITTER OUTPUT POWER SETTINGS: 31.86 dBm

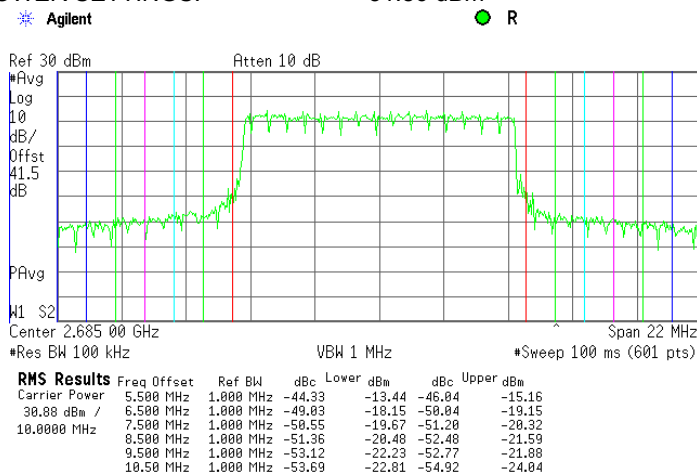



HERMON LABORATORIES

Test specification:		Section 27.53(m)(2), Band edge emissions	
Test procedure:		47 CFR, Sections 2.1051, 27.53; TIA/EIA-603-D, Section 2.2.13	
Test mode:		Compliance	
Date(s):		20-Jul-15 - 22-Jul-15	
Temperature: 23 °C		Air Pressure: 1005 hPa	
Remarks:		Verdict: PASS	
		Relative Humidity: 48 %	
		Power Supply: 48 VDC	

Plot 7.3.13 Spurious emission at band edges test results at low carrier frequency, 5 MHz EBW

FREQUENCY: 2498.5 MHz
DETECTOR USED: Average
MODULATION: 64QAM
MODULATING SIGNAL: PRBS
TRANSMITTER OUTPUT POWER SETTINGS: 29.02 dBm

Agilent 08:54:09 Jul 22, 2015

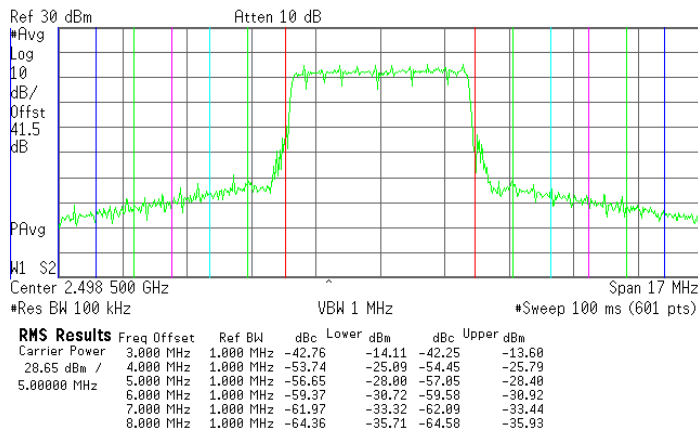

Plot 7.3.14 Spurious emission at band edges test results at mid carrier frequency, 5 MHz EBW

FREQUENCY: 2575 MHz
DETECTOR USED: Average
MODULATION: 64QAM
MODULATING SIGNAL: PRBS
TRANSMITTER OUTPUT POWER SETTINGS: 35.1 dBm

Agilent 09:23:59 Jul 22, 2015

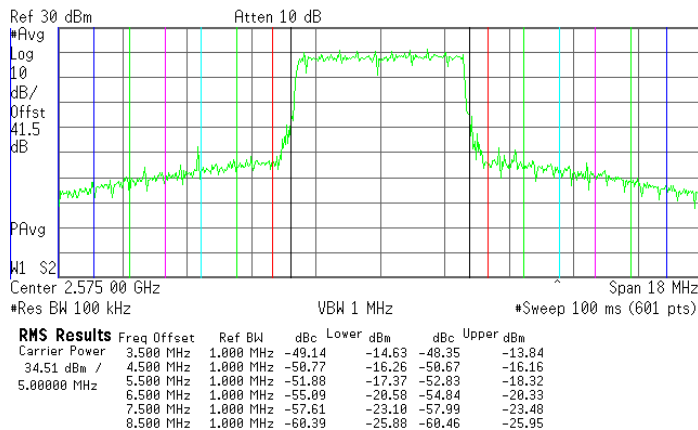



HERMON LABORATORIES

Test specification:	Section 27.53(m)(2), Band edge emissions		
Test procedure:	47 CFR, Sections 2.1051, 27.53; TIA/EIA-603-D, Section 2.2.13		
Test mode:	Compliance	Verdict:	PASS
Date(s):	20-Jul-15 - 22-Jul-15		
Temperature: 23 °C	Air Pressure: 1005 hPa	Relative Humidity: 48 %	Power Supply: 48 VDC
Remarks:			

Plot 7.3.15 Spurious emission at band edges test results at high carrier frequency, 5 MHz EBW

FREQUENCY: 2687.5 MHz
DETECTOR USED: Average
MODULATION: 64QAM
MODULATING SIGNAL: PRBS
TRANSMITTER OUTPUT POWER SETTINGS: 27.1 dBm

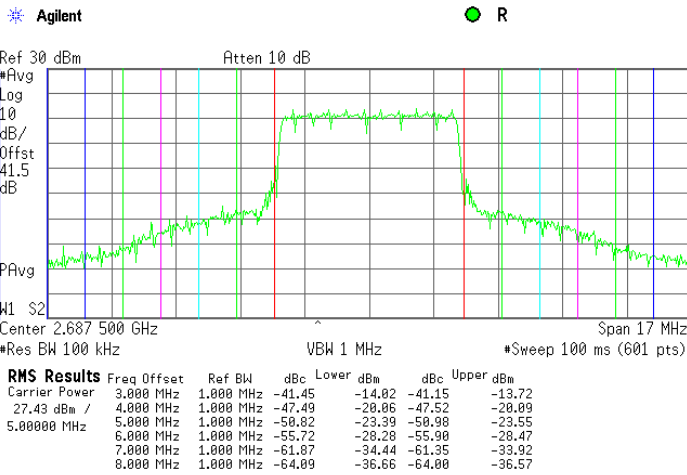

Plot 7.3.16 Spurious emission at band edges test results at low carrier frequency, 10 MHz EBW

FREQUENCY: 2496.0 – 2690.0 MHz
DETECTOR USED: Average
MODULATION: 64QAM
MODULATING SIGNAL: PRBS
TRANSMITTER OUTPUT POWER SETTINGS: 33.23 dBm

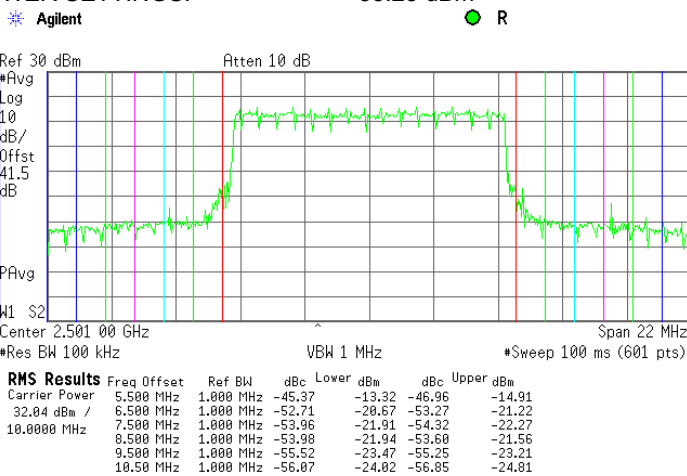



HERMON LABORATORIES

Test specification:		Section 27.53(m)(2), Band edge emissions	
Test procedure:		47 CFR, Sections 2.1051, 27.53; TIA/EIA-603-D, Section 2.2.13	
Test mode:		Compliance	
Date(s):		20-Jul-15 - 22-Jul-15	
Temperature: 23 °C		Air Pressure: 1005 hPa	
Relative Humidity: 48 %		Power Supply: 48 VDC	
Remarks:			
		Verdict: PASS	

Plot 7.3.17 Spurious emission at band edges test results at mid carrier frequency, 10 MHz EBW

FREQUENCY: 2596 MHz
 DETECTOR USED: Average
 MODULATION: 64QAM
 MODULATING SIGNAL: PRBS
 TRANSMITTER OUTPUT POWER SETTINGS: 35.4 dBm

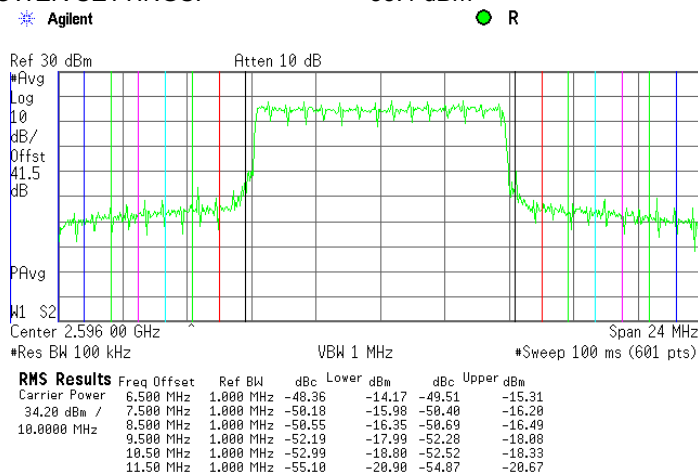

Plot 7.3.18 Spurious emission at band edges test results at high carrier frequency, 10 MHz EBW

FREQUENCY: 2685 MHz
 DETECTOR USED: Average
 MODULATION: 64QAM
 MODULATING SIGNAL: PRBS
 TRANSMITTER OUTPUT POWER SETTINGS: 31.75 dBm

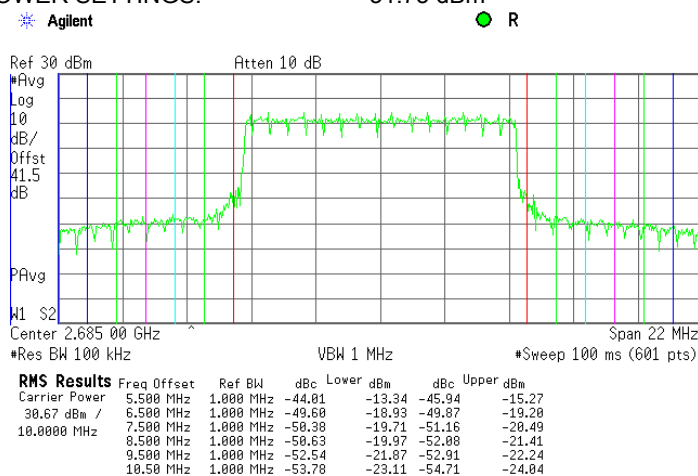



Test specification:		Section 27.53(m)(2), Band edge emissions	
Test procedure:		47 CFR, Sections 2.1051, 27.53; TIA/EIA-603-D, Section 2.2.13	
Test mode:		Verdict: PASS	
Date(s):		22-Jul-15 - 23-Jul-15	
Temperature: 23 °C	Air Pressure: 1006 hPa	Relative Humidity: 48 %	Power Supply: 48 VDC
Remarks:			

7.4 Spurious emissions at RF antenna connector test

7.4.1 General

This test was performed to measure spurious emissions at RF antenna connector. Specification test limits are given in Table 7.4.1.

Table 7.4.1 Spurious emission limits

Frequency, MHz	Attenuation below carrier, dBc	Spurious emissions, dBm
Base and fixed user stations		
0.009 – 10th harmonic	43+10logP(W)**	-13.0

* - spurious emission limits do not apply to the channel edge emission investigated in course of band edge emission testing

** - P is transmitter output power in watts

7.4.2 Test procedure

7.4.2.1 The EUT was set up as shown in Figure 7.4.1, energized and its proper operation was checked.

7.4.2.2 The EUT was adjusted to produce maximum available for end user RF output power.

7.4.2.3 The spurious emission was measured with spectrum analyzer as provided in Table 7.4.2 and associated plots.

Figure 7.4.1 Spurious emission test setup, single output

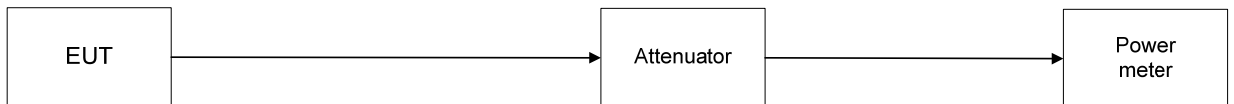



Test specification:		Section 27.53(m)(2), Band edge emissions	
Test procedure:		47 CFR, Sections 2.1051, 27.53; TIA/EIA-603-D, Section 2.2.13	
Test mode:		Compliance	
Date(s):		22-Jul-15 - 23-Jul-15	
Temperature: 23 °C		Air Pressure: 1006 hPa	
		Relative Humidity: 48 %	
		Power Supply: 48 VDC	
Remarks:			
Verdict: PASS			

Table 7.4.2 Spurious emission test results

ASSIGNED FREQUENCY RANGE: 2496.0 – 2690 MHz
 INVESTIGATED FREQUENCY RANGE: 0.009 – 26900 MHz
 VIDEO BANDWIDTH: ≥ Resolution bandwidth
 MODULATION: 16 QAM
 MODULATING SIGNAL: PRBS
 TRANSMITTER OUTPUT POWER SETTINGS: Maximum
 TESTED RF CHAIN: 1

Frequency, MHz	SA reading, dBm	Attenuation, dB	Detector used	RBW, kHz	Spurious emission, dBm	Limit, dBm	Margin, dB*	Verdict
Low carrier frequency								
2490.0	-16.91	included	Peak	1000	-16.91	-13.00	-3.91	Pass
2599.0	-16.75	included	Peak	1000	-16.75	-13.00	-3.75	Pass
Mid carrier frequency								
2400.000	-19.01	included	Peak	1000	-19.01	-13.00	-6.01	Pass
2566.433	-27.28	included	Average	1000	-27.28	-13.00	-14.28	Pass
2584.648	-26.76	included	Average	1000	-26.76	-13.00	-13.76	Pass
2753.557	-36.48	included	Average	1000	-36.48	-13.00	-23.48	Pass
High carrier frequency								
2364.0	-26.71	included	Peak	1000	-26.71	-13.00	-13.71	Pass
2678.763	-22.41	included	Average	1000	-22.41	-13.00	-9.41	Pass
2735.583	-36.51	included	Average	1000	-36.51	-13.00	-23.51	Pass

*- Margin = Spurious emission – specification limit.

Reference numbers of test equipment used

HL 3301	HL 3302	HL 3667	HL 3818	HL 3901	HL 4293		
---------	---------	---------	---------	---------	---------	--	--

Full description is given in Appendix A.



Test specification:		Section 27.53(m)(2), Band edge emissions	
Test procedure:		47 CFR, Sections 2.1051, 27.53; TIA/EIA-603-D, Section 2.2.13	
Test mode:		Verdict: PASS	
Date(s):		22-Jul-15 - 23-Jul-15	
Temperature: 23 °C	Air Pressure: 1006 hPa	Relative Humidity: 48 %	Power Supply: 48 VDC
Remarks:			

Plot 7.4.1 Spurious emission measurements in 9 - 150 kHz range at low carrier frequency

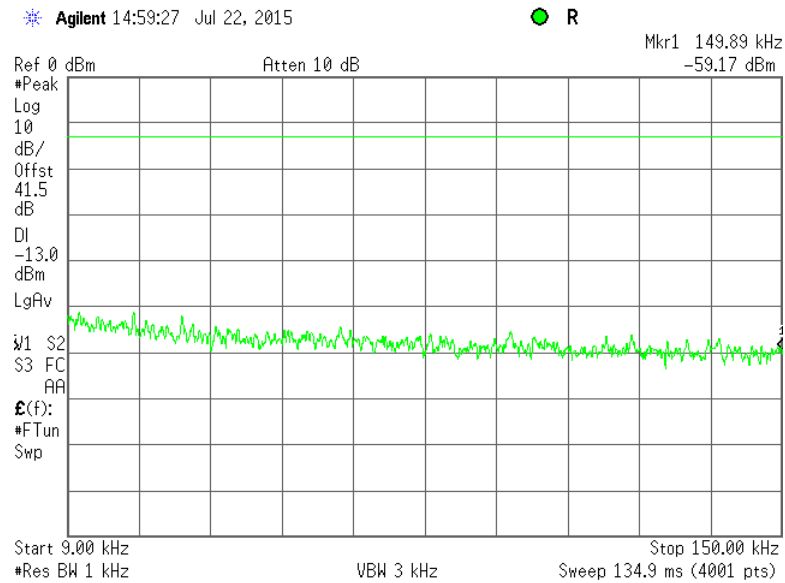

Plot 7.4.2 Spurious emission measurements in 9 - 150 kHz range at mid carrier frequency

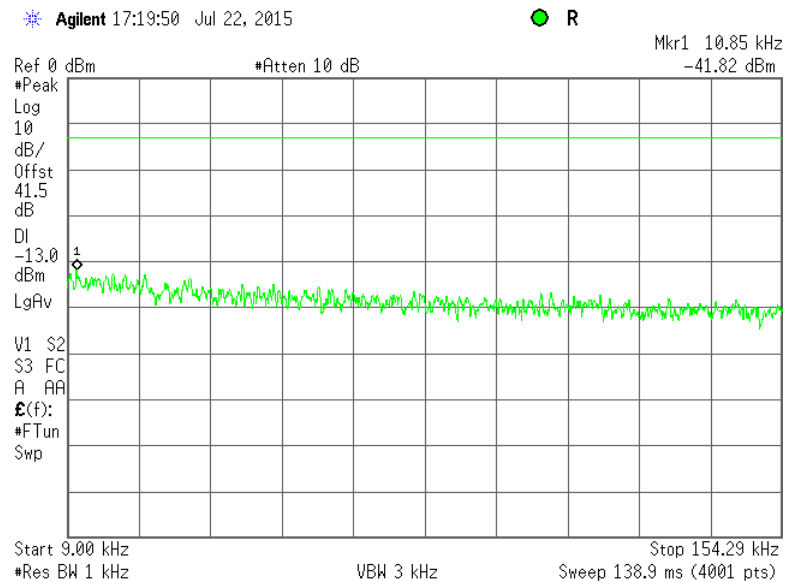



Test specification:		Section 27.53(m)(2), Band edge emissions	
Test procedure:		47 CFR, Sections 2.1051, 27.53; TIA/EIA-603-D, Section 2.2.13	
Test mode:		Verdict: PASS	
Date(s):		22-Jul-15 - 23-Jul-15	
Temperature: 23 °C	Air Pressure: 1006 hPa	Relative Humidity: 48 %	Power Supply: 48 VDC
Remarks:			

Plot 7.4.3 Spurious emission measurements in 9 - 150 kHz range at high carrier frequency

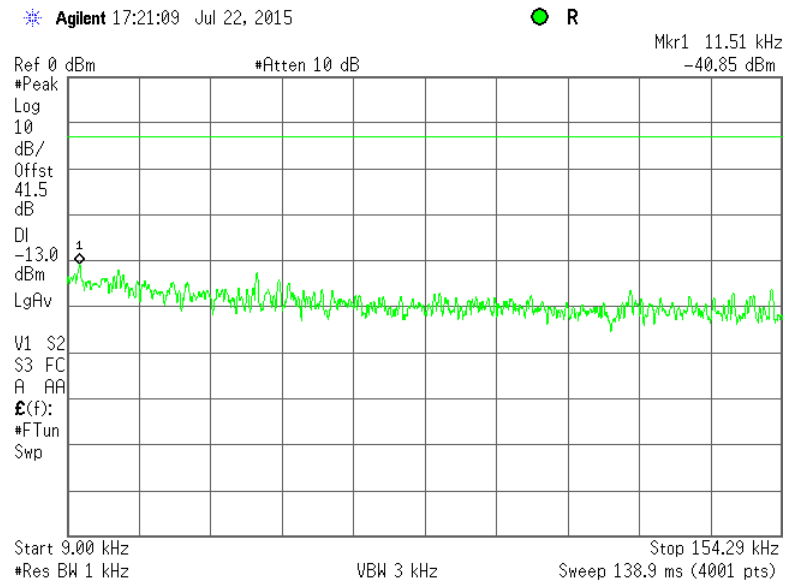

Plot 7.4.4 Spurious emission measurements in 0.15 - 30.0 MHz range at low carrier frequency

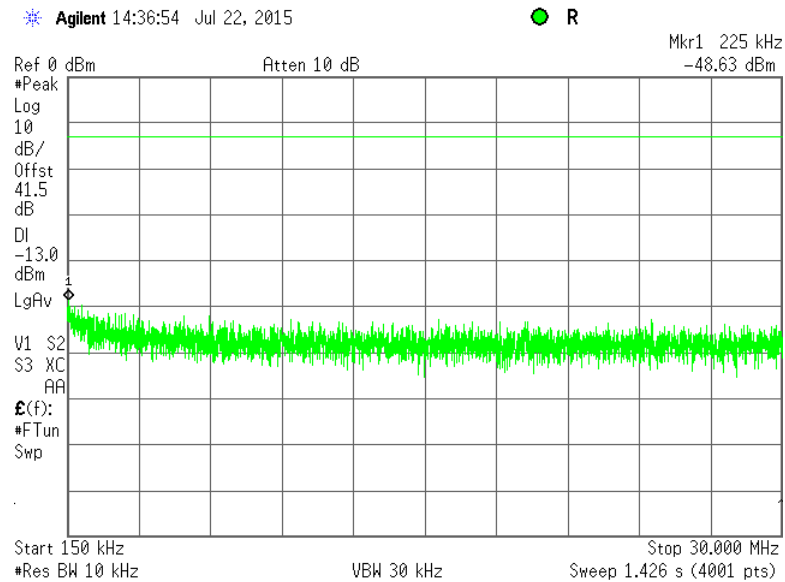



Test specification:		Section 27.53(m)(2), Band edge emissions	
Test procedure:		47 CFR, Sections 2.1051, 27.53; TIA/EIA-603-D, Section 2.2.13	
Test mode:		Verdict: PASS	
Date(s):		22-Jul-15 - 23-Jul-15	
Temperature: 23 °C	Air Pressure: 1006 hPa	Relative Humidity: 48 %	Power Supply: 48 VDC
Remarks:			

Plot 7.4.5 Spurious emission measurements in 0.15 - 30.0 MHz range at mid carrier frequency

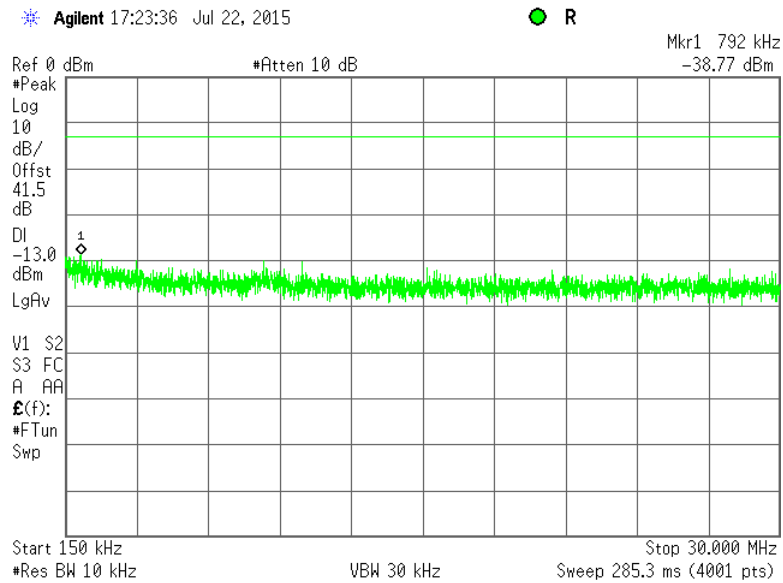

Plot 7.4.6 Spurious emission measurements in 0.15 - 30.0 MHz range at high carrier frequency

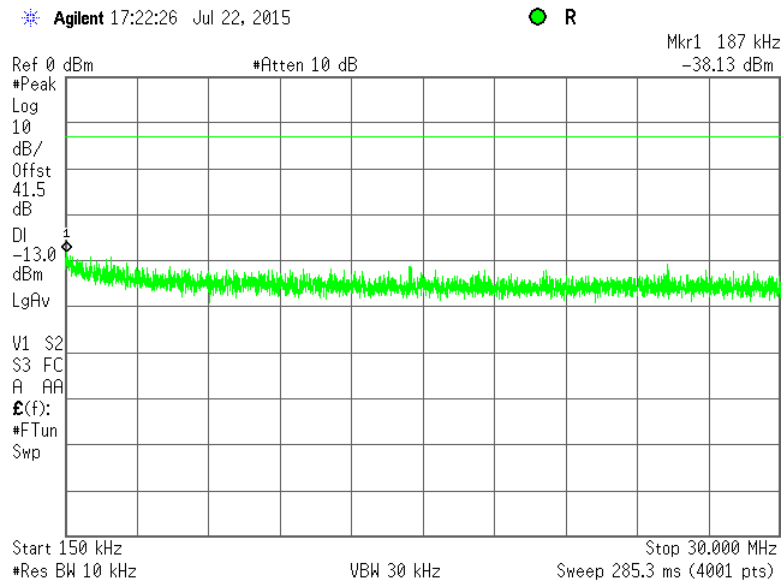



Test specification:		Section 27.53(m)(2), Band edge emissions	
Test procedure:		47 CFR, Sections 2.1051, 27.53; TIA/EIA-603-D, Section 2.2.13	
Test mode:		Verdict:	
Compliance		PASS	
Date(s):		22-Jul-15 - 23-Jul-15	
Temperature: 23 °C	Air Pressure: 1006 hPa	Relative Humidity: 48 %	Power Supply: 48 VDC
Remarks:			

Plot 7.4.7 Spurious emission measurements in 30 - 1000 MHz range at low carrier frequency

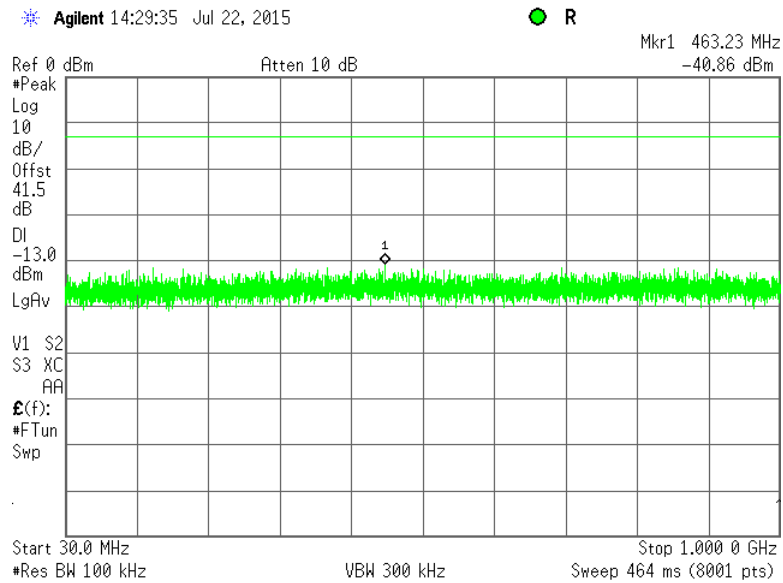

Plot 7.4.8 Spurious emission measurements in 30 - 1000 MHz range at mid carrier frequency

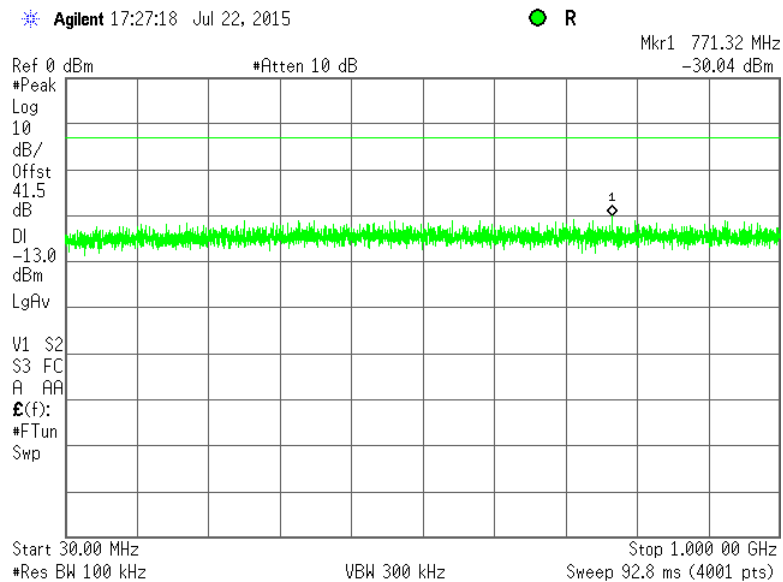



HERMON LABORATORIES

Test specification:		Section 27.53(m)(2), Band edge emissions	
Test procedure:		47 CFR, Sections 2.1051, 27.53; TIA/EIA-603-D, Section 2.2.13	
Test mode:		Verdict: PASS	
Date(s):		22-Jul-15 - 23-Jul-15	
Temperature: 23 °C	Air Pressure: 1006 hPa	Relative Humidity: 48 %	Power Supply: 48 VDC
Remarks:			

Plot 7.4.9 Spurious emission measurements in 30 - 1000 MHz range at high carrier frequency

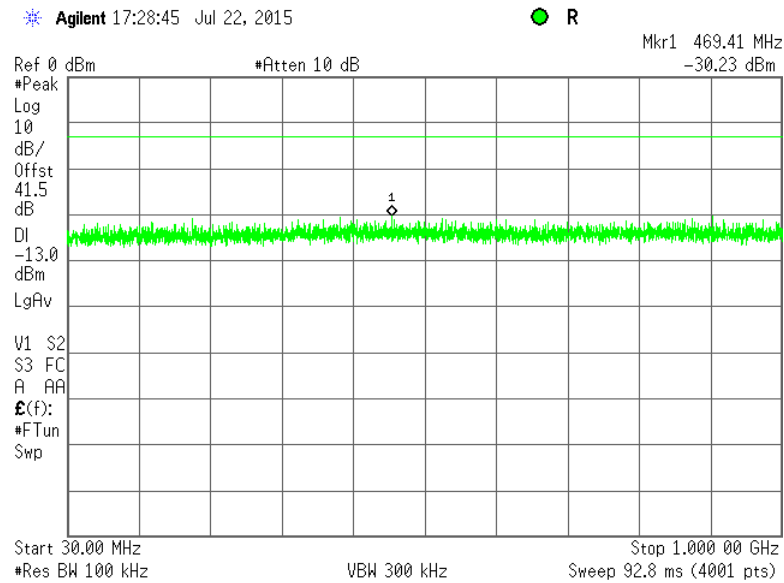

Plot 7.4.10 Spurious emission measurements in 1000 - 2490 MHz range at low carrier frequency

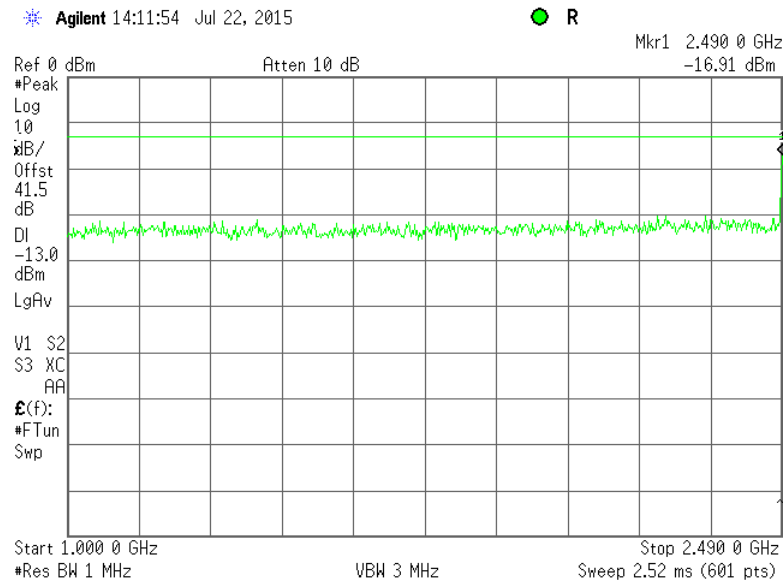



Test specification:		Section 27.53(m)(2), Band edge emissions	
Test procedure:		47 CFR, Sections 2.1051, 27.53; TIA/EIA-603-D, Section 2.2.13	
Test mode:		Verdict:	
Compliance		PASS	
Date(s):		22-Jul-15 - 23-Jul-15	
Temperature: 23 °C	Air Pressure: 1006 hPa	Relative Humidity: 48 %	Power Supply: 48 VDC
Remarks:			

Plot 7.4.11 Spurious emission measurements in 2490 - 8000 MHz range at low carrier frequency

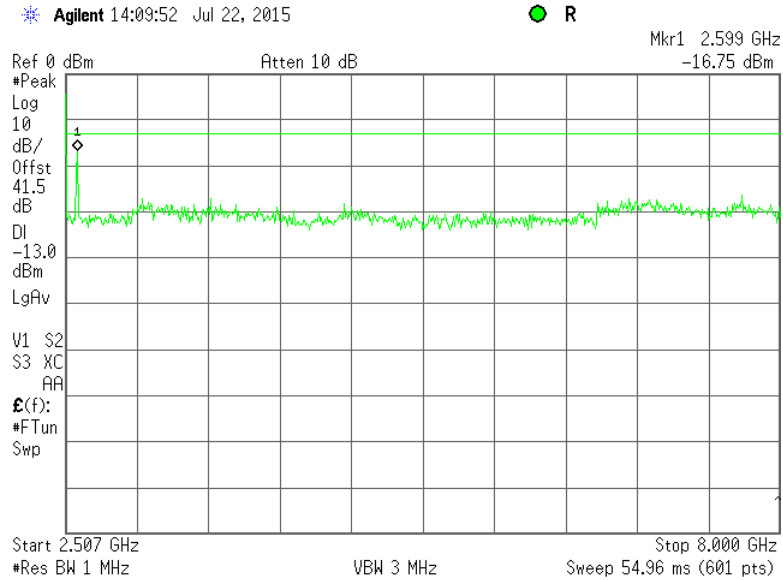

Plot 7.4.12 Spurious emission measurements in 1000 - 2566.5 MHz at mid carrier frequency

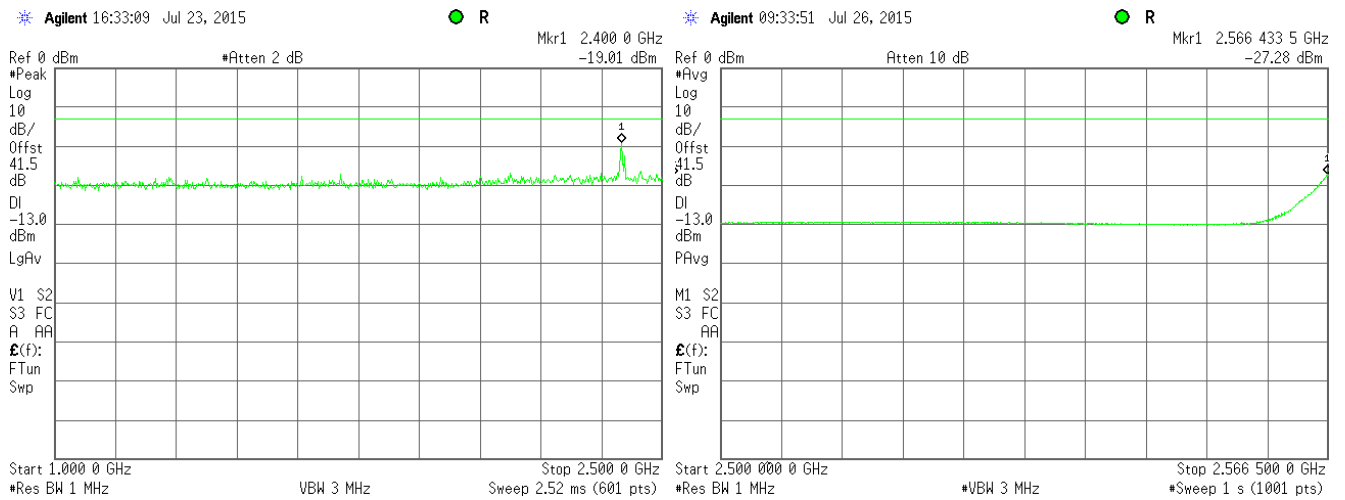



HERMON LABORATORIES

Test specification: Section 27.53(m)(2), Band edge emissions			
Test procedure: 47 CFR, Sections 2.1051, 27.53; TIA/EIA-603-D, Section 2.2.13			
Test mode: Compliance		Verdict: PASS	
Date(s): 22-Jul-15 - 23-Jul-15			
Temperature: 23 °C	Air Pressure: 1006 hPa	Relative Humidity: 48 %	Power Supply: 48 VDC
Remarks:			

Plot 7.4.13 Spurious emission measurements in 2566.5 - 8000 MHz at mid carrier frequency

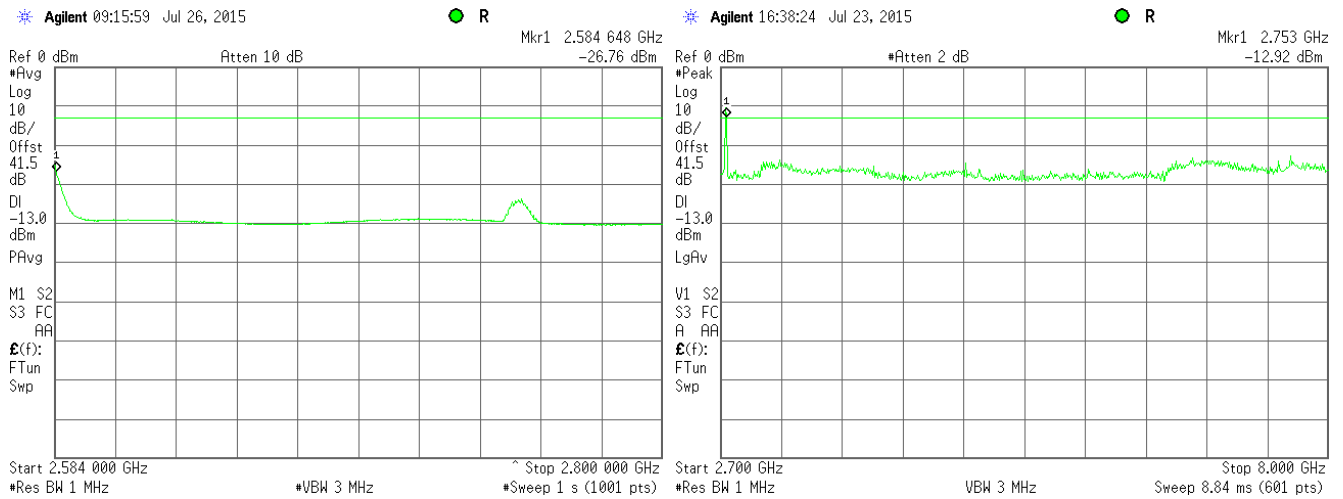

Plot 7.4.14 Spurious emission measurements in 1000 - 2679 MHz at high carrier frequency

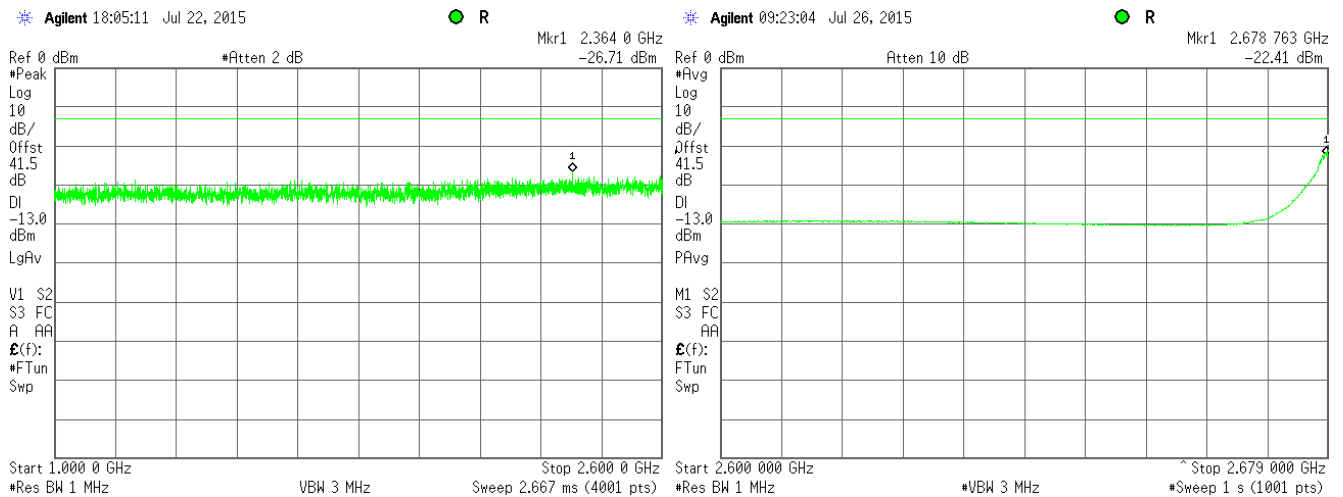



HERMON LABORATORIES

Test specification:		Section 27.53(m)(2), Band edge emissions	
Test procedure:		47 CFR, Sections 2.1051, 27.53; TIA/EIA-603-D, Section 2.2.13	
Test mode:		Verdict:	
Compliance		PASS	
Date(s):		22-Jul-15 - 23-Jul-15	
Temperature: 23 °C	Air Pressure: 1006 hPa	Relative Humidity: 48 %	Power Supply: 48 VDC
Remarks:			

Plot 7.4.15 Spurious emission measurements in 2679 - 8000 MHz at high carrier frequency

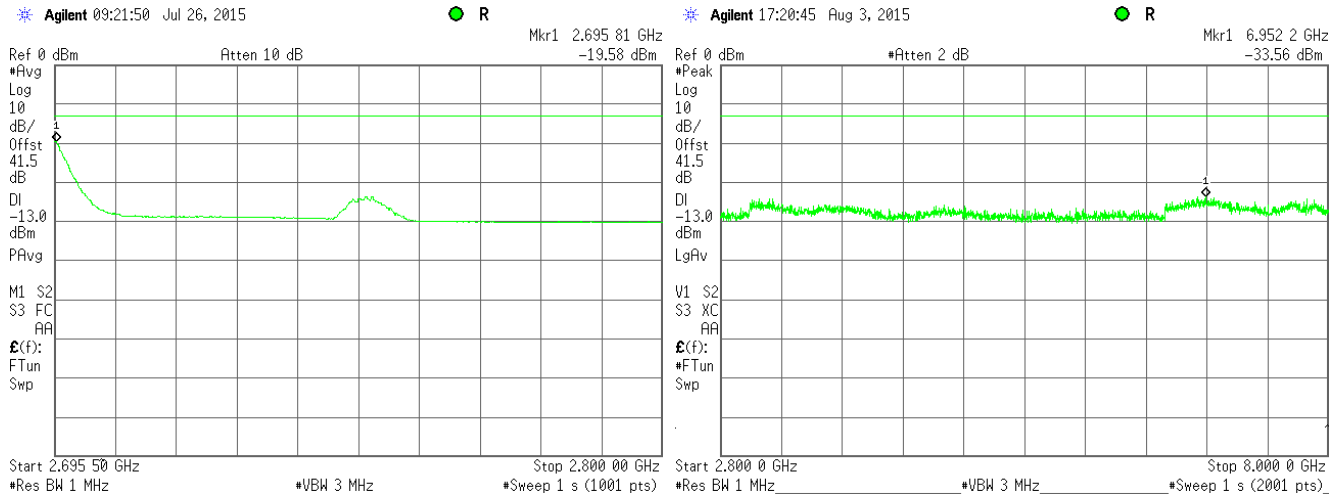

Plot 7.4.16 Spurious emission measurements in 8000 - 18000 MHz range at low carrier frequency

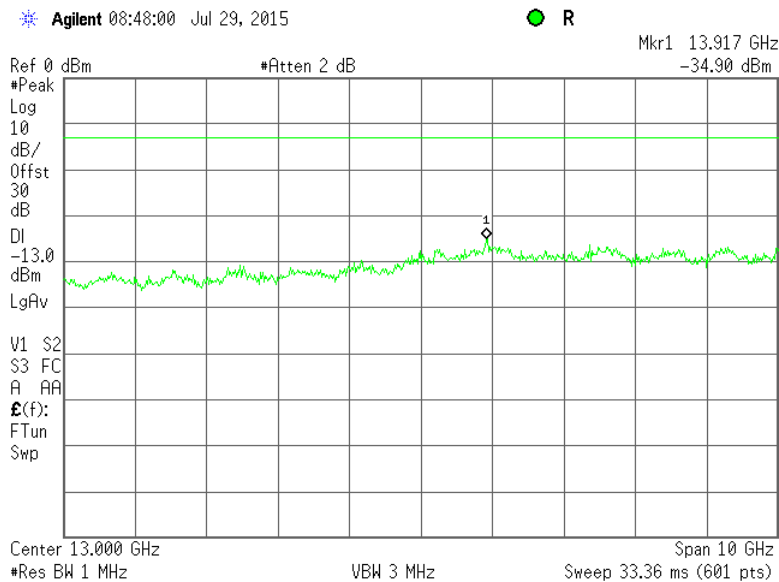



Test specification:		Section 27.53(m)(2), Band edge emissions	
Test procedure:		47 CFR, Sections 2.1051, 27.53; TIA/EIA-603-D, Section 2.2.13	
Test mode:		Verdict: PASS	
Date(s):		22-Jul-15 - 23-Jul-15	
Temperature: 23 °C	Air Pressure: 1006 hPa	Relative Humidity: 48 %	Power Supply: 48 VDC
Remarks:			

Plot 7.4.17 Spurious emission measurements in 8000 - 18000 MHz at mid carrier frequency

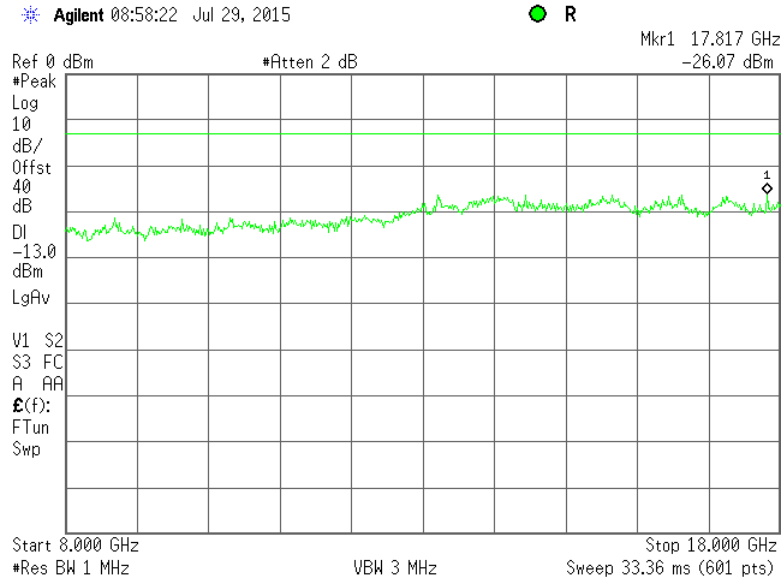

Plot 7.4.18 Spurious emission measurements in 8000 - 18000 MHz at high carrier frequency

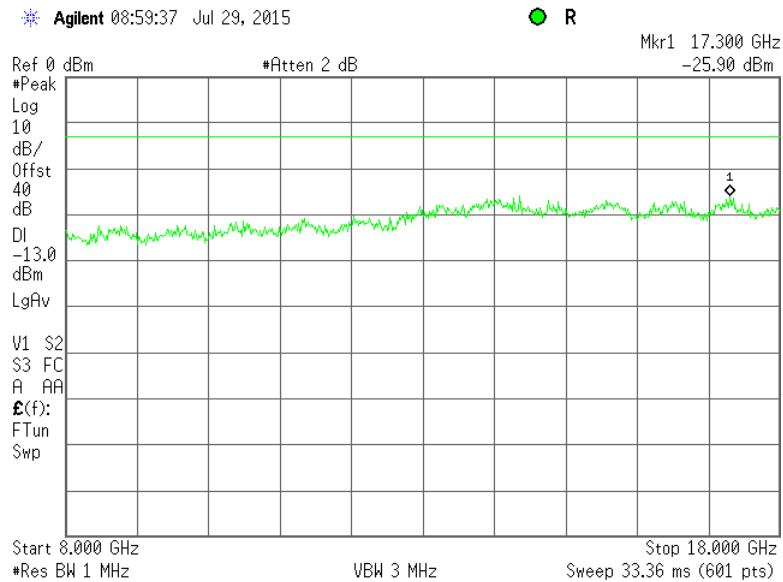



Test specification:		Section 27.53(m)(2), Band edge emissions	
Test procedure:		47 CFR, Sections 2.1051, 27.53; TIA/EIA-603-D, Section 2.2.13	
Test mode:		Verdict: PASS	
Date(s):		22-Jul-15 - 23-Jul-15	
Temperature: 23 °C	Air Pressure: 1006 hPa	Relative Humidity: 48 %	Power Supply: 48 VDC
Remarks:			

Plot 7.4.19 Spurious emission measurements in 18000 - 27000 MHz range at low carrier frequency

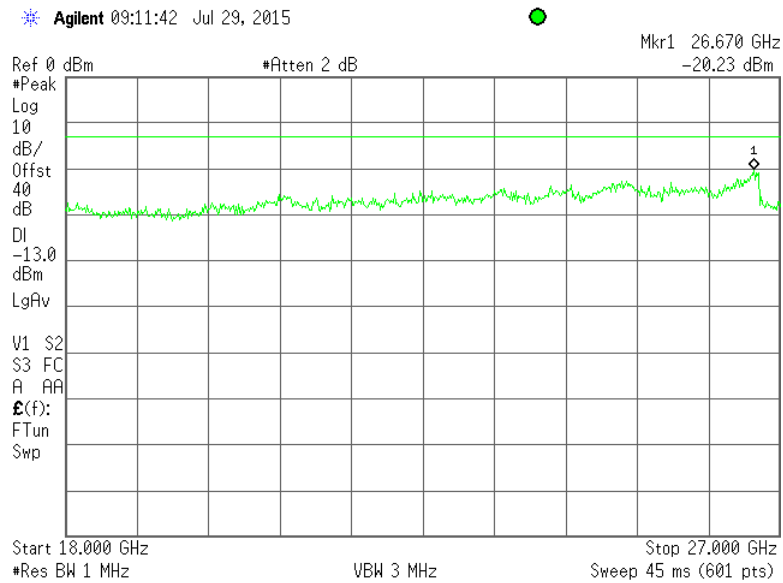

Plot 7.4.20 Spurious emission measurements in 18000 - 27000 MHz at mid carrier frequency

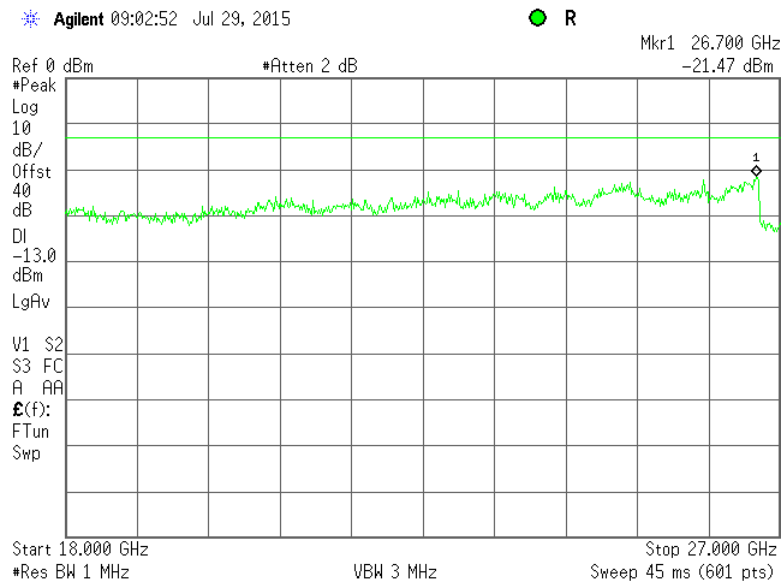



HERMON LABORATORIES

Test specification:		Section 27.53(m)(2), Band edge emissions	
Test procedure:		47 CFR, Sections 2.1051, 27.53; TIA/EIA-603-D, Section 2.2.13	
Test mode:		Verdict: PASS	
Date(s):		22-Jul-15 - 23-Jul-15	
Temperature: 23 °C	Air Pressure: 1006 hPa	Relative Humidity: 48 %	Power Supply: 48 VDC
Remarks:			

Plot 7.4.21 Spurious emission measurements in 18000 - 27000 MHz at high carrier frequency

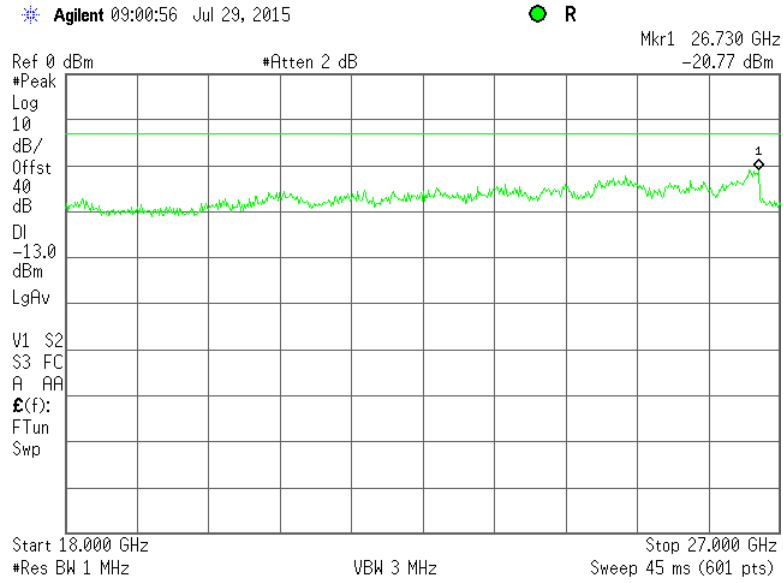



Test specification:	Section 27.53(m)(2), Radiated spurious emissions		
Test procedure:	47 CFR, Sections 2.1053; TIA/EIA-603-D, Section 2.2.12		
Test mode:	Compliance	Verdict:	PASS
Date(s):	26-Jul-15		
Temperature: 23 °C	Air Pressure: 10007 hPa	Relative Humidity: 49 %	Power Supply: 48 VDC
Remarks:			

7.5 Radiated spurious emission measurements

7.5.1 General

This test was performed to measure radiated spurious emissions from the EUT. Specification test limits are given in Table 7.5.1.

Table 7.5.1 Radiated spurious emission test limits

Frequency, MHz	Attenuation below carrier, dBc	ERP of spurious, dBm	Equivalent field strength limit @ 3m, dB(μV/m)***
0.009 – 10 th harmonic*	43+10logP** fixed	-13	84.4

* - Excluding the band emission

** - P is transmitter output power in Watts

*** - Equivalent field strength limit was calculated from maximum allowed ERP of spurious as follows:
 $E = \sqrt{(30 \times P \times 1.64)} / r$, where P is ERP in Watts, 1.64 is numeric gain of ideal dipole and r is antenna to EUT distance in meters

7.5.2 Test procedure for spurious emission field strength measurements in 9 kHz to 30 MHz band

7.5.2.1 The EUT was set up as shown in Figure 7.5.1, energized and the performance check was conducted.

7.5.2.2 The specified frequency range was investigated with antenna connected to spectrum analyzer. To find maximum radiation the turntable was rotated 360° and the measuring antenna was rotated around its vertical axis.

7.5.2.3 The worst test results (the lowest margins) were recorded in Table 7.5.2 and shown in the associated plots.

7.5.3 Test procedure for spurious emission field strength measurements above 30 MHz

7.5.3.1 The EUT was set up as shown in Figure 7.5.2, energized and the performance check was conducted.

7.5.3.2 The specified frequency range was investigated with antenna connected to spectrum analyzer. To find maximum radiation the turntable was rotated 360° and the measuring antenna height was swept from 1 to 4 m in both, vertical and horizontal, polarizations.

7.5.3.3 The worst test results (the lowest margins) were recorded in Table 7.5.2 and shown in the associated plots..



Test specification:		Section 27.53(m)(2), Radiated spurious emissions	
Test procedure:		47 CFR, Sections 2.1053; TIA/EIA-603-D, Section 2.2.12	
Test mode:		Compliance	
Date(s):		26-Jul-15	
Temperature: 23 °C		Air Pressure: 10007 hPa	
Relative Humidity: 49 %		Power Supply: 48 VDC	
Remarks:			
Verdict:		PASS	

Figure 7.5.1 Setup for spurious emission field strength measurements in 9 kHz to 30 MHz band

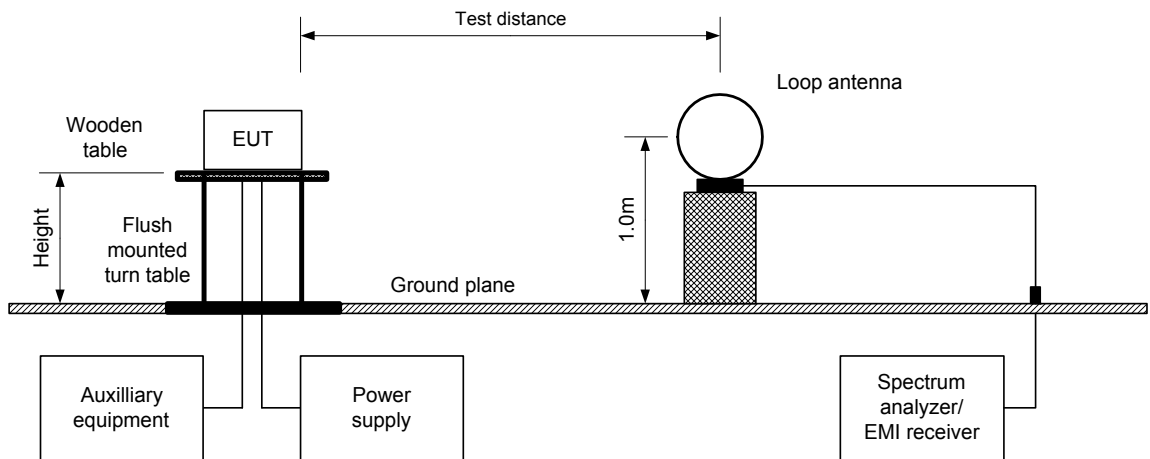
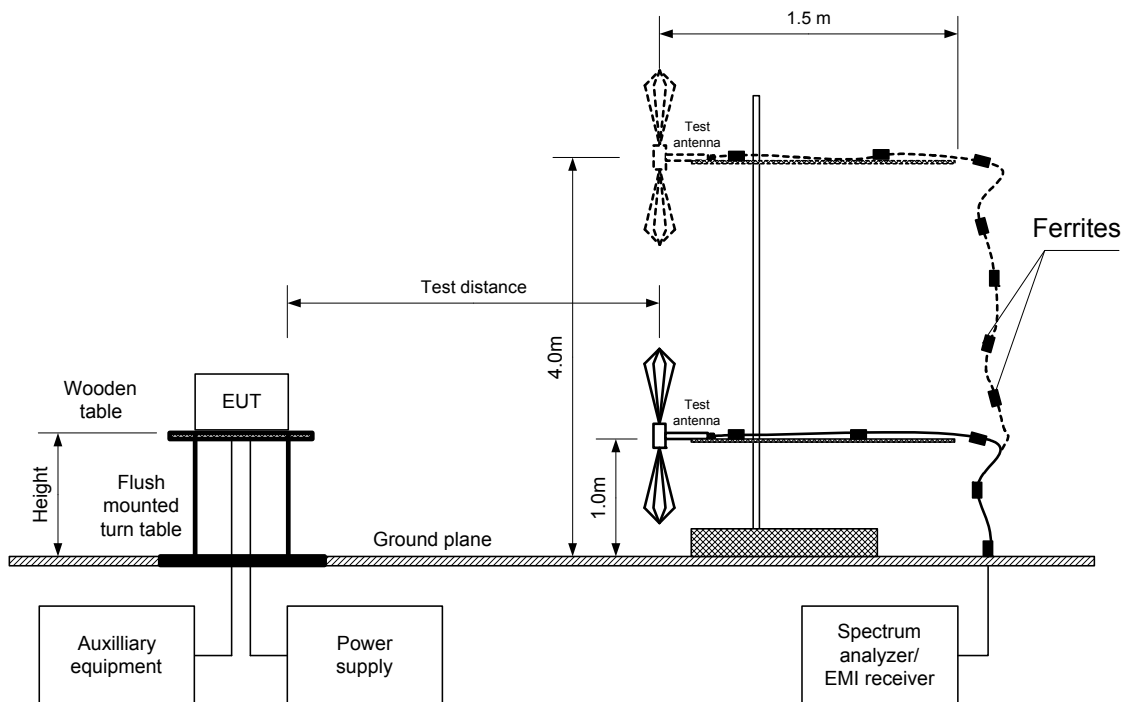

Figure 7.5.2 Setup for spurious emission field strength measurements above 30 MHz





Test specification:	Section 27.53(m)(2), Radiated spurious emissions		
Test procedure:	47 CFR, Sections 2.1053; TIA/EIA-603-D, Section 2.2.12		
Test mode:	Compliance	Verdict:	PASS
Date(s):	26-Jul-15		
Temperature: 23 °C	Air Pressure: 10007 hPa	Relative Humidity: 49 %	Power Supply: 48 VDC
Remarks:			

Table 7.5.2 Spurious emission field strength test results

ASSIGNED FREQUENCY RANGE: 2496.0 – 2690.0 MHz
TEST DISTANCE: 3 m
TEST SITE: Semi anechoic chamber / OATS
EUT HEIGHT: 0.8 m
INVESTIGATED FREQUENCY RANGE: 0.009 – 27000 MHz
DETECTOR USED: Peak
VIDEO BANDWIDTH: > Resolution bandwidth
TEST ANTENNA TYPE: Active loop (9 kHz – 30 MHz)
Biconilog (30 MHz – 1000 MHz)
Double ridged guide (above 1000 MHz)

MODULATION: 16QAM
MODULATING SIGNAL: PRBS
BIT RATE: 12,565 Mbps
TRANSMITTER OUTPUT POWER SETTINGS: Maximum

Frequency, MHz	Field strength, dB(µV/m)	Limit, dB(µV/m)	Margin, dB*	RBW, kHz	Antenna polarization	Antenna height, m	Turn-table position**, degrees
Low carrier frequency 2498.5 MHz							
No emissions were found							
Mid carrier frequency 2575 MHz							
No emissions were found							
High carrier frequency 2687.5 MHz							
No emissions were found							

Verdict: Pass

*- Margin = Field strength of spurious – calculated field strength limit.

**- EUT front panel refers to 0 degrees position of turntable.

Reference numbers of test equipment used

HL 0446	HL 0521	HL 0604	HL 0768	HL 0769	HL 1984	HL 2780	HL 2871
HL 4114	HL 4150	HL 4353					

Full description is given in Appendix A.



HERMON LABORATORIES

Test specification:		Section 27.53(m)(2), Radiated spurious emissions	
Test procedure:		47 CFR, Sections 2.1053; TIA/EIA-603-D, Section 2.2.12	
Test mode:		Compliance	
Date(s):		26-Jul-15	
Temperature: 23 °C		Air Pressure: 10007 hPa	
Remarks:		Verdict: PASS	
		Relative Humidity: 49 %	
		Power Supply: 48 VDC	

Plot 7.5.1 Radiated emission measurements in 9 - 150 kHz range

TEST SITE: Semi anechoic chamber
 CARRIER FREQUENCY: Low
 ANTENNA POLARIZATION: Vertical and Horizontal
 TEST DISTANCE: 3 m

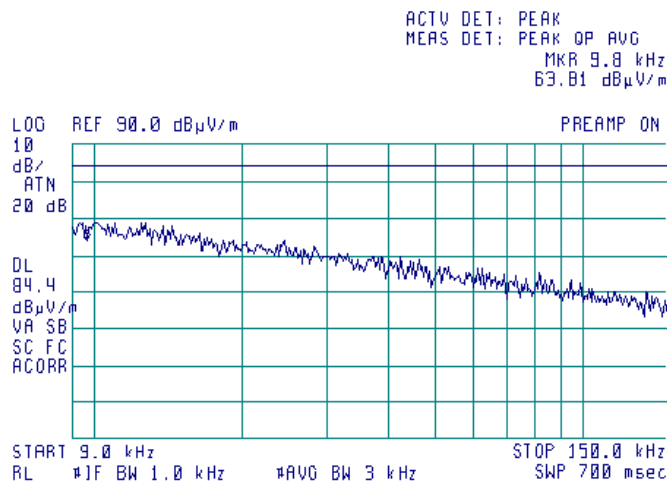

Plot 7.5.2 Radiated emission measurements in 9 - 150 kHz range

TEST SITE: Semi anechoic chamber
 CARRIER FREQUENCY: Mid
 ANTENNA POLARIZATION: Vertical and Horizontal
 TEST DISTANCE: 3 m

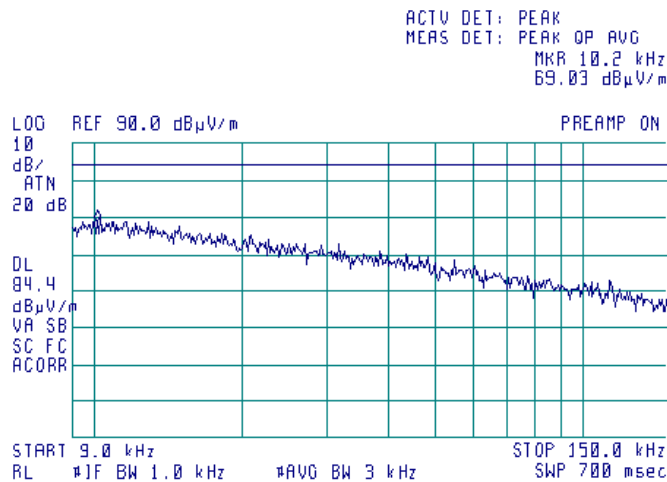



HERMON LABORATORIES

Test specification:	Section 27.53(m)(2), Radiated spurious emissions		
Test procedure:	47 CFR, Sections 2.1053; TIA/EIA-603-D, Section 2.2.12		
Test mode:	Compliance	Verdict:	PASS
Date(s):	26-Jul-15		
Temperature: 23 °C	Air Pressure: 10007 hPa	Relative Humidity: 49 %	Power Supply: 48 VDC
Remarks:			

Plot 7.5.3 Radiated emission measurements in 9 - 150 kHz range

TEST SITE: Semi anechoic chamber
 CARRIER FREQUENCY: High
 ANTENNA POLARIZATION: Vertical and Horizontal
 TEST DISTANCE: 3 m

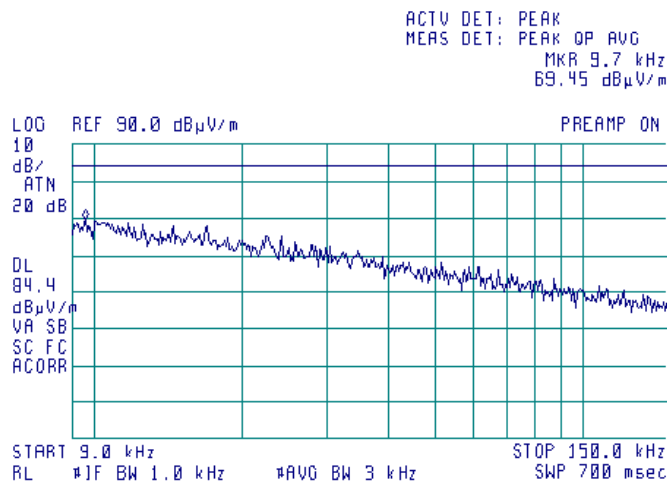

Plot 7.5.4 Radiated emission measurements in 0.15 - 30 MHz range

TEST SITE: Semi anechoic chamber
 CARRIER FREQUENCY: Low
 ANTENNA POLARIZATION: Vertical and Horizontal
 TEST DISTANCE: 3 m

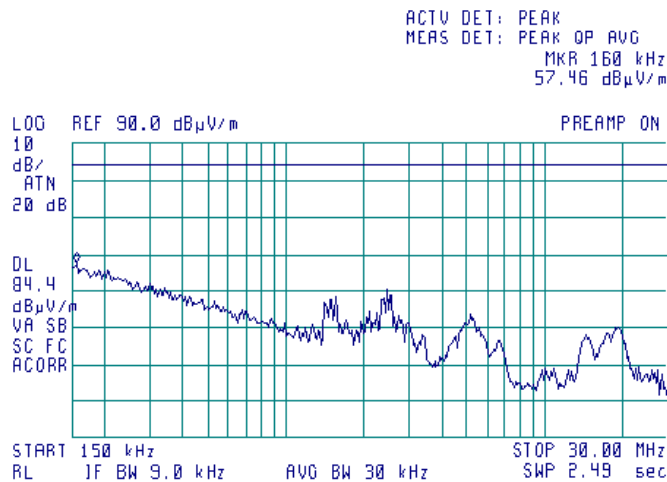



HERMON LABORATORIES

Test specification:	Section 27.53(m)(2), Radiated spurious emissions		
Test procedure:	47 CFR, Sections 2.1053; TIA/EIA-603-D, Section 2.2.12		
Test mode:	Compliance	Verdict:	PASS
Date(s):	26-Jul-15		
Temperature: 23 °C	Air Pressure: 10007 hPa	Relative Humidity: 49 %	Power Supply: 48 VDC
Remarks:			

Plot 7.5.5 Radiated emission measurements in 0.15 - 30 MHz range

TEST SITE: Semi anechoic chamber
 CARRIER FREQUENCY: Mid
 ANTENNA POLARIZATION: Vertical and Horizontal
 TEST DISTANCE: 3 m

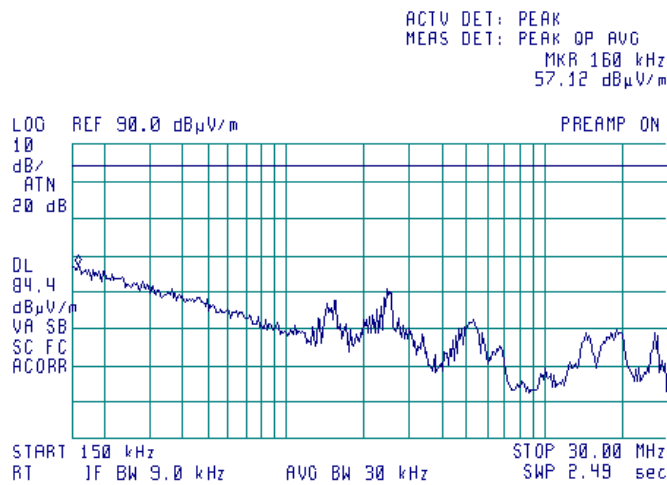

Plot 7.5.6 Radiated emission measurements in 0.15 - 30 MHz range

TEST SITE: Semi anechoic chamber
 CARRIER FREQUENCY: High
 ANTENNA POLARIZATION: Vertical and Horizontal
 TEST DISTANCE: 3 m

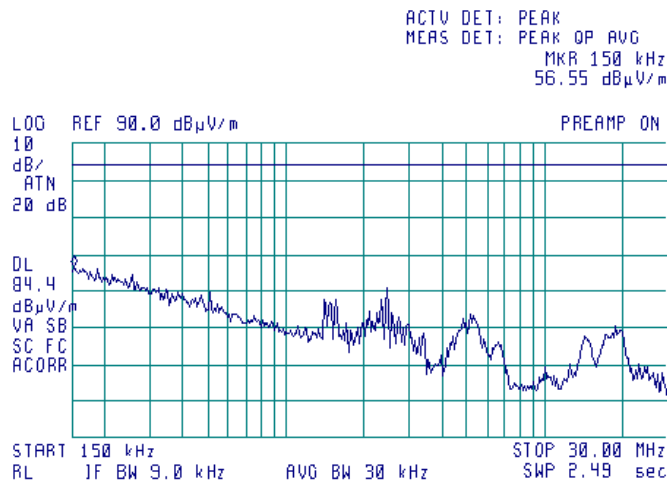



HERMON LABORATORIES

Test specification:		Section 27.53(m)(2), Radiated spurious emissions	
Test procedure:		47 CFR, Sections 2.1053; TIA/EIA-603-D, Section 2.2.12	
Test mode:		Verdict:	
Compliance		PASS	
Date(s):		26-Jul-15	
Temperature: 23 °C	Air Pressure: 10007 hPa	Relative Humidity: 49 %	Power Supply: 48 VDC
Remarks:			

Plot 7.5.7 Radiated emission measurements in 30 - 1000 MHz range

TEST SITE:	Semi anechoic chamber
CARRIER FREQUENCY:	Low
ANTENNA POLARIZATION:	Vertical and Horizontal
TEST DISTANCE:	3 m

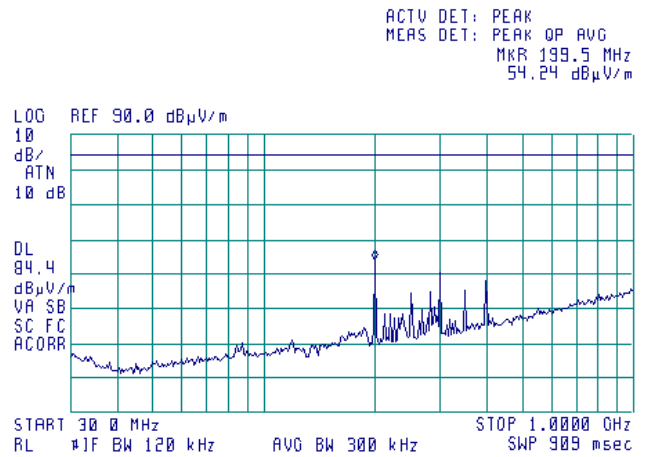
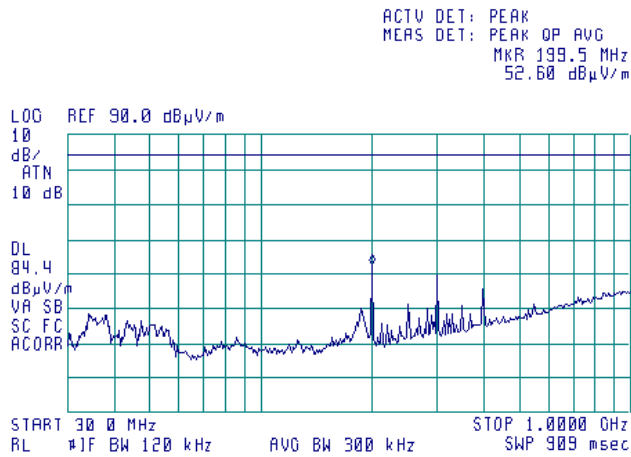

Plot 7.5.8 Radiated emission measurements in 30 - 1000 MHz range

TEST SITE:	Semi anechoic chamber
CARRIER FREQUENCY:	Mid
ANTENNA POLARIZATION:	Vertical and Horizontal
TEST DISTANCE:	3 m

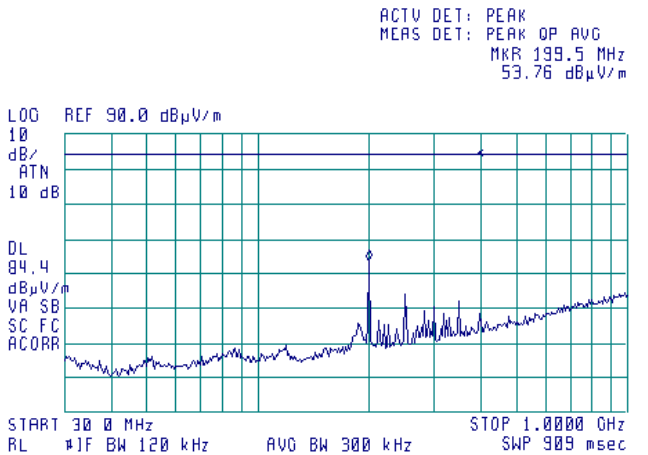
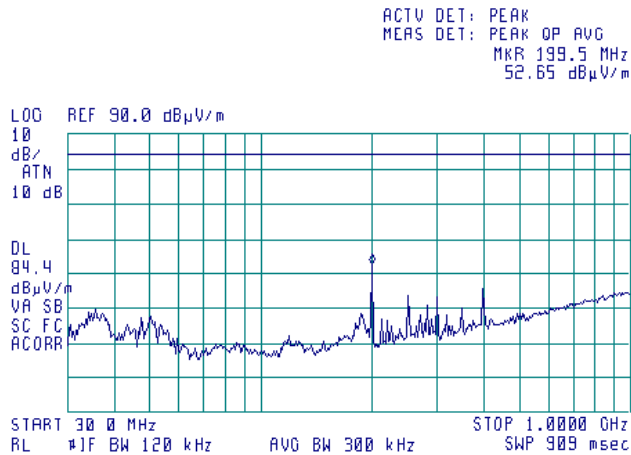



HERMON LABORATORIES

Test specification:		Section 27.53(m)(2), Radiated spurious emissions	
Test procedure:		47 CFR, Sections 2.1053; TIA/EIA-603-D, Section 2.2.12	
Test mode:		Verdict:	
Compliance		PASS	
Date(s):		26-Jul-15	
Temperature: 23 °C	Air Pressure: 10007 hPa	Relative Humidity: 49 %	Power Supply: 48 VDC
Remarks:			

Plot 7.5.9 Radiated emission measurements in 30 - 1000 MHz range

TEST SITE:	Semi anechoic chamber
CARRIER FREQUENCY:	High
ANTENNA POLARIZATION:	Vertical and Horizontal
TEST DISTANCE:	3 m

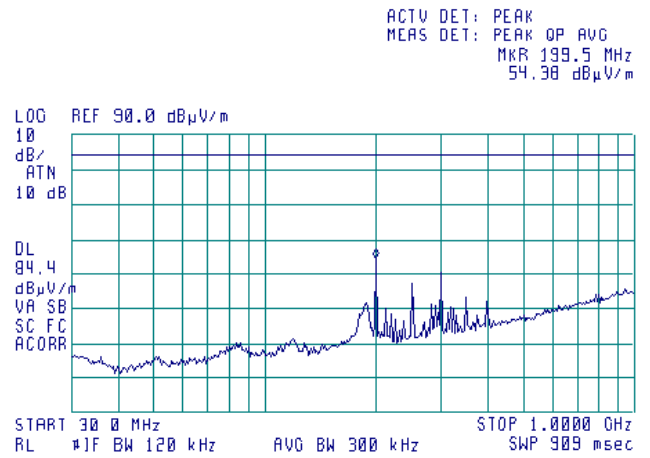
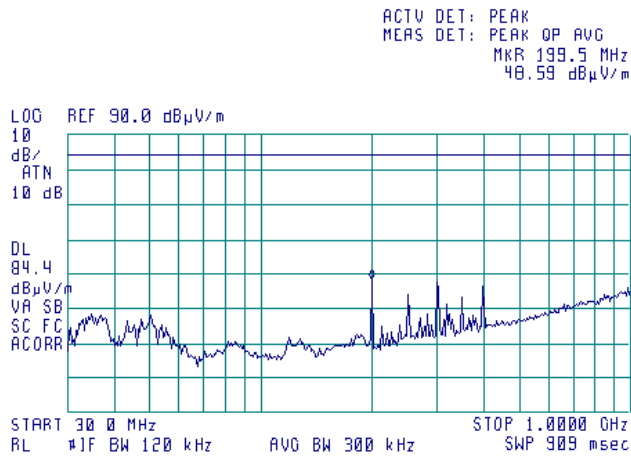

Plot 7.5.10 Radiated emission measurements in 1000 – 6000 MHz range

TEST SITE:	Semi anechoic chamber
CARRIER FREQUENCY:	Low
ANTENNA POLARIZATION:	Vertical and Horizontal
TEST DISTANCE:	3 m

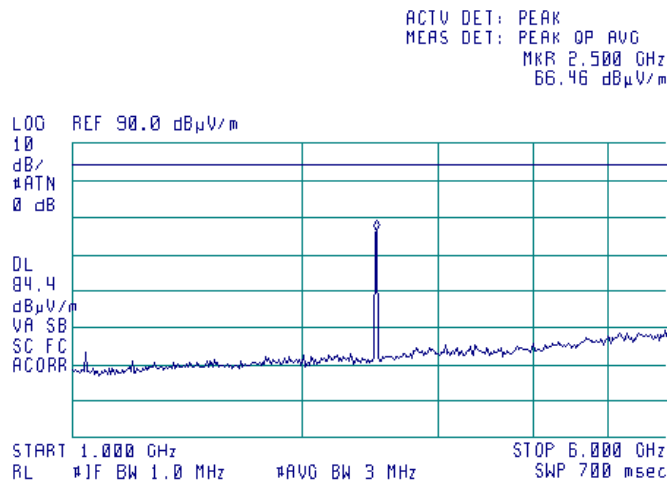

2498.5 MHz is a low carrier frequency



HERMON LABORATORIES

Test specification:		Section 27.53(m)(2), Radiated spurious emissions	
Test procedure:		47 CFR, Sections 2.1053; TIA/EIA-603-D, Section 2.2.12	
Test mode:		Compliance	
Date(s):		26-Jul-15	
Temperature: 23 °C		Air Pressure: 10007 hPa	
Remarks:		Verdict: PASS	
		Relative Humidity: 49 %	
		Power Supply: 48 VDC	

Plot 7.5.11 Radiated emission measurements in 1000 – 6000 MHz range

TEST SITE:	Semi anechoic chamber
CARRIER FREQUENCY:	Mid
ANTENNA POLARIZATION:	Vertical and Horizontal
TEST DISTANCE:	3 m

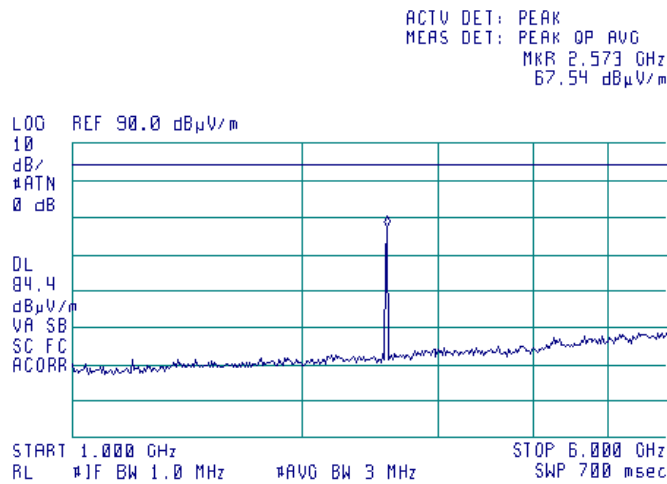

2575 MHz is a mid carrier frequency

Plot 7.5.12 Radiated emission measurements in 1000 – 6000 MHz range

TEST SITE:	Semi anechoic chamber
CARRIER FREQUENCY:	High
ANTENNA POLARIZATION:	Vertical and Horizontal
TEST DISTANCE:	3 m

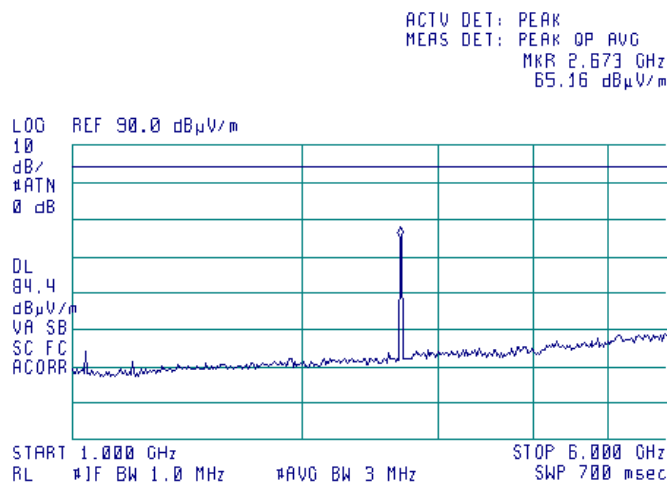

2687.5 MHz is high carrier frequency



HERMON LABORATORIES

Test specification:		Section 27.53(m)(2), Radiated spurious emissions	
Test procedure:		47 CFR, Sections 2.1053; TIA/EIA-603-D, Section 2.2.12	
Test mode:		Verdict:	
Compliance		PASS	
Date(s):		26-Jul-15	
Temperature: 23 °C	Air Pressure: 10007 hPa	Relative Humidity: 49 %	Power Supply: 48 VDC
Remarks:			

Plot 7.5.13 Radiated emission measurements in 6000 – 18000 MHz range

TEST SITE: Semi anechoic chamber
 CARRIER FREQUENCY: Low
 ANTENNA POLARIZATION: Vertical and Horizontal
 TEST DISTANCE: 3 m

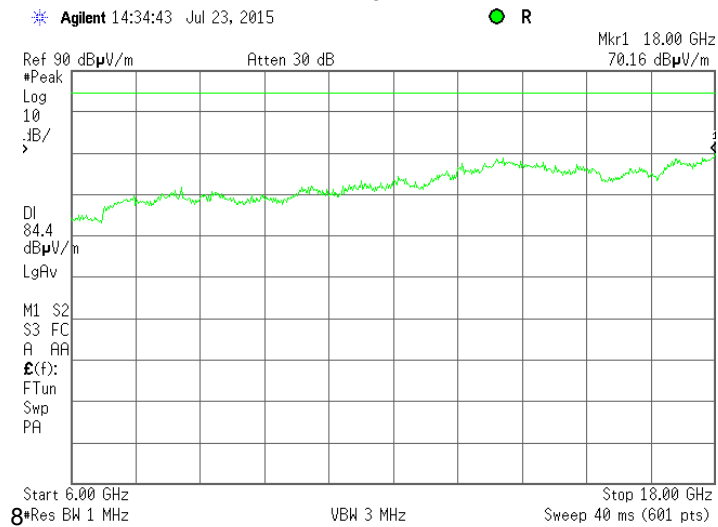

Plot 7.5.14 Radiated emission measurements in 6000 – 18000 MHz range

TEST SITE: Semi anechoic chamber
 CARRIER FREQUENCY: Mid
 ANTENNA POLARIZATION: Vertical and Horizontal
 TEST DISTANCE: 3 m

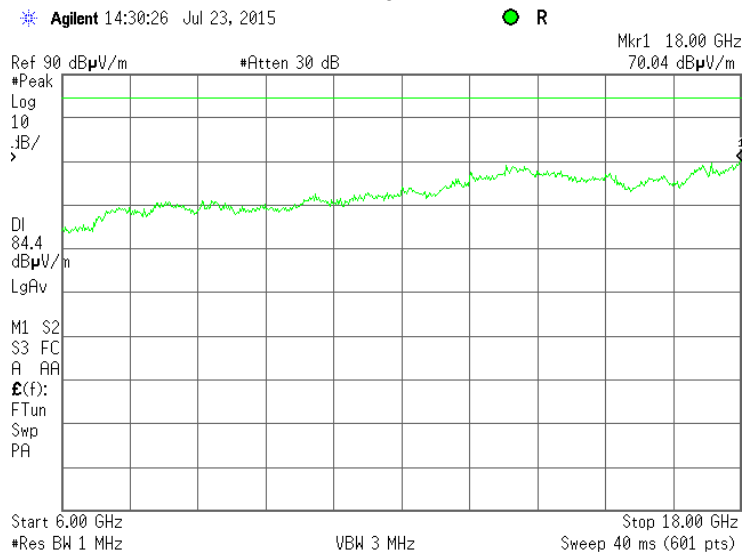



HERMON LABORATORIES

Test specification:		Section 27.53(m)(2), Radiated spurious emissions	
Test procedure:		47 CFR, Sections 2.1053; TIA/EIA-603-D, Section 2.2.12	
Test mode:		Compliance	
Date(s):		26-Jul-15	
Temperature: 23 °C		Air Pressure: 10007 hPa	
Remarks:		Verdict: PASS	
		Relative Humidity: 49 %	
		Power Supply: 48 VDC	

Plot 7.5.15 Radiated emission measurements in 6000 – 18000 MHz range

TEST SITE: Semi anechoic chamber
 CARRIER FREQUENCY: High
 ANTENNA POLARIZATION: Vertical and Horizontal
 TEST DISTANCE: 3 m

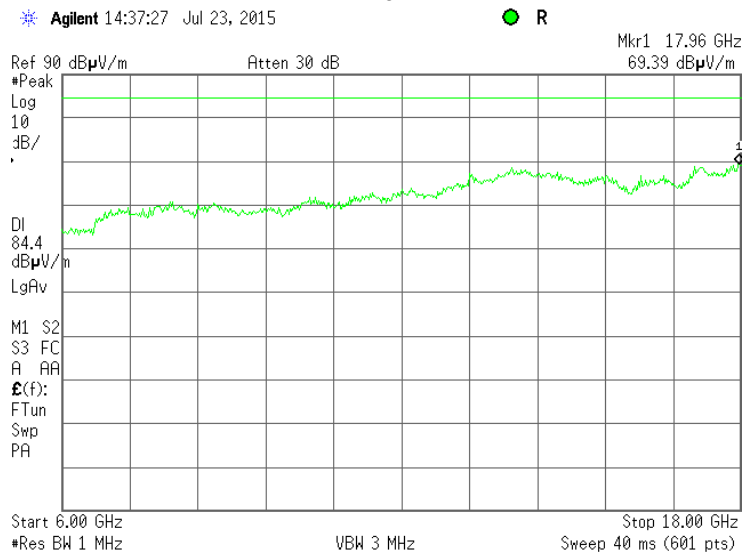

Plot 7.5.16 Radiated emission measurements in 18000 – 26500 MHz range

TEST SITE: OATS
 CARRIER FREQUENCY: Low
 ANTENNA POLARIZATION: Vertical and Horizontal
 TEST DISTANCE: 3 m

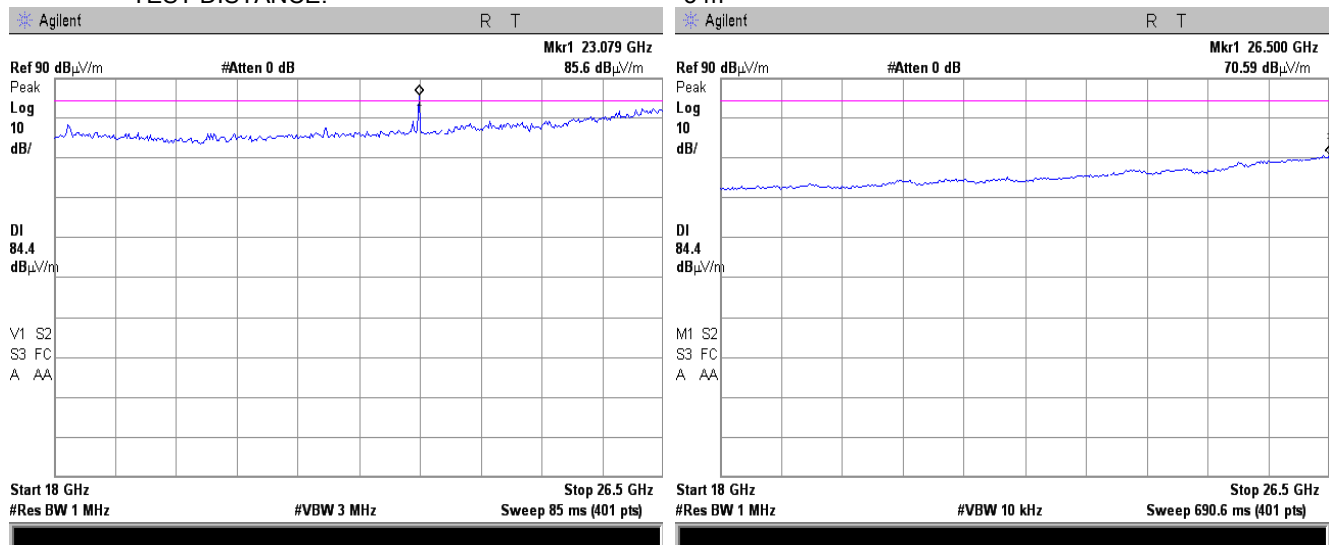

Frequency 23.079 GHz is an ambient noise



HERMON LABORATORIES

Test specification: Section 27.53(m)(2), Radiated spurious emissions			
Test procedure: 47 CFR, Sections 2.1053; TIA/EIA-603-D, Section 2.2.12			
Test mode: Compliance	Verdict: PASS		
Date(s): 26-Jul-15			
Temperature: 23 °C	Air Pressure: 10007 hPa	Relative Humidity: 49 %	Power Supply: 48 VDC
Remarks:			

Plot 7.5.17 Radiated emission measurements in 18000 – 26500 MHz range

TEST SITE:
CARRIER FREQUENCY:
ANTENNA POLARIZATION:
TEST DISTANCE:

OATS
Mid
Vertical and Horizontal
3 m

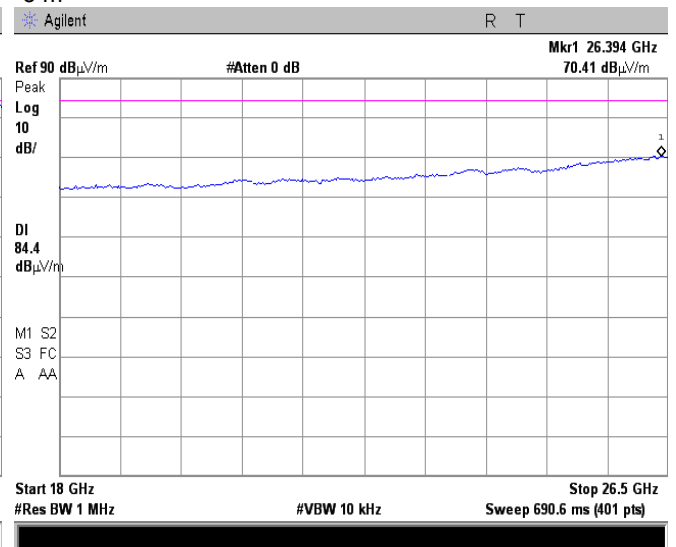
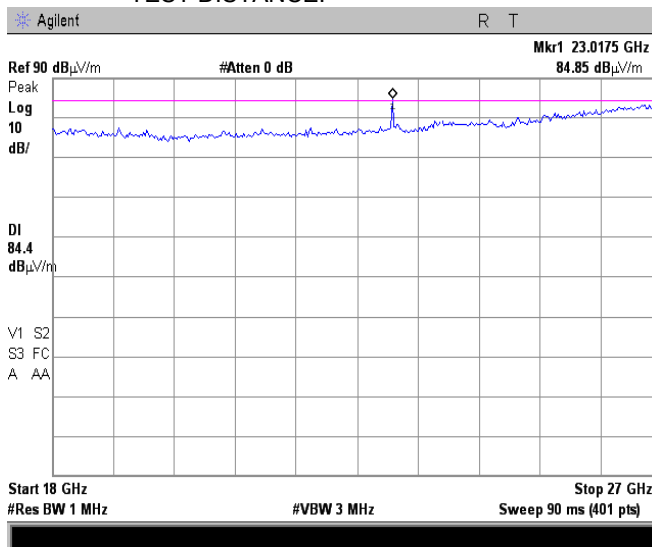

Frequency 23.018 GHz is an ambient noise

Plot 7.5.18 Radiated emission measurements in 18000 – 26900 MHz range

TEST SITE:
CARRIER FREQUENCY:
ANTENNA POLARIZATION:
TEST DISTANCE:

OATS
High
Vertical and Horizontal
3 m

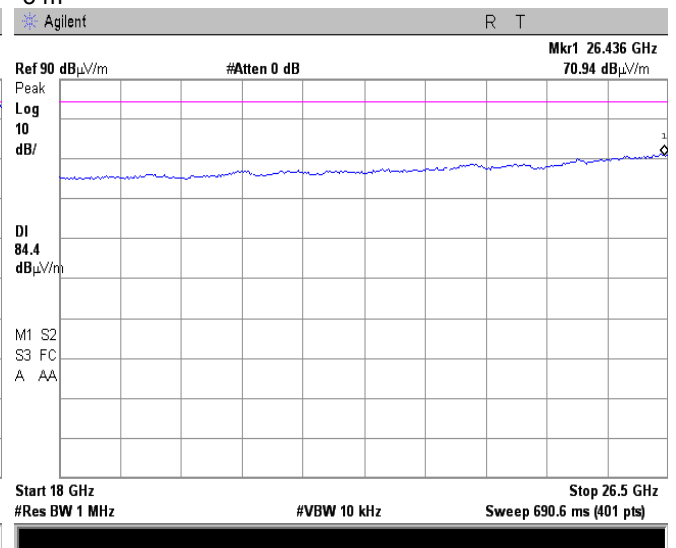
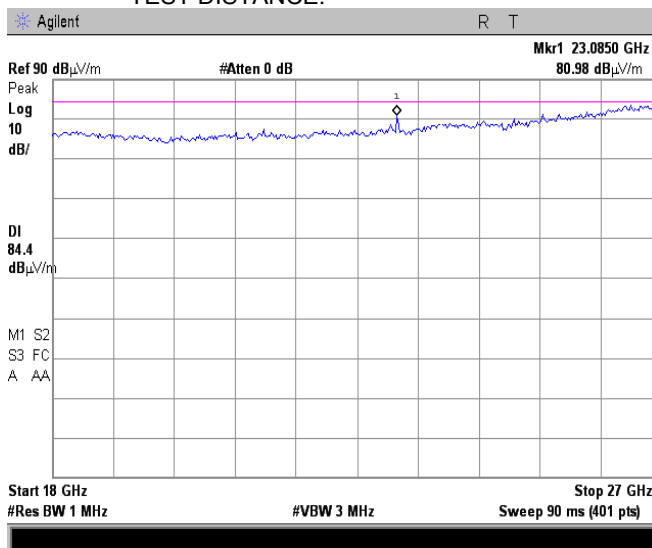

Frequency 23.085 GHz is an ambient noise



HERMON LABORATORIES

Test specification: Section 27.53(m)(2), Radiated spurious emissions			
Test procedure: 47 CFR, Sections 2.1053; TIA/EIA-603-D, Section 2.2.12			
Test mode: Compliance	Verdict: PASS		
Date(s): 26-Jul-15			
Temperature: 23 °C	Air Pressure: 10007 hPa	Relative Humidity: 49 %	Power Supply: 48 VDC
Remarks:			

Plot 7.5.19 Radiated emission measurements in 26500 – 27000 MHz range

TEST SITE:	OATS
CARRIER FREQUENCY:	Low
ANTENNA POLARIZATION:	Vertical and Horizontal
TEST DISTANCE:	3 m

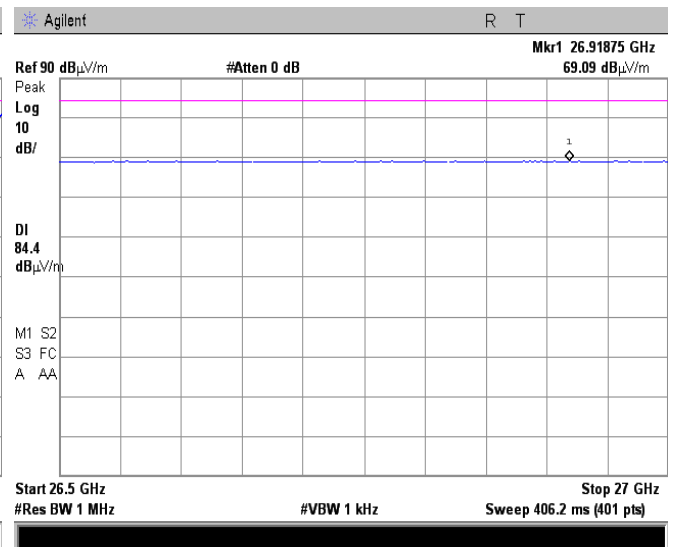
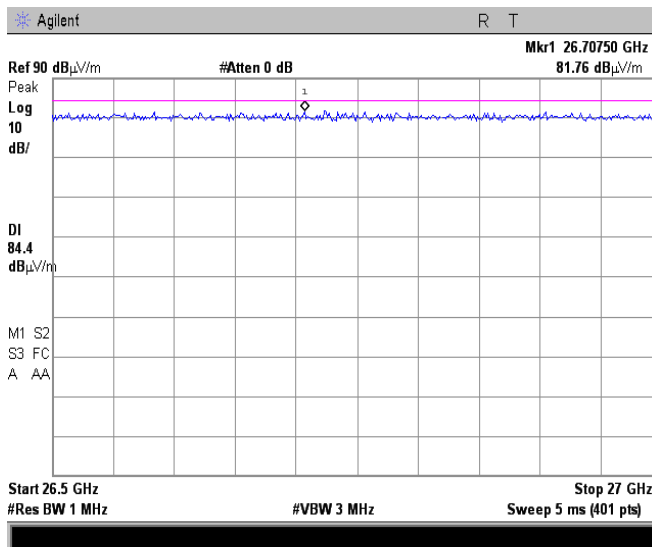

Plot 7.5.20 Radiated emission measurements in 26500 – 27000 MHz range

TEST SITE:	OATS
CARRIER FREQUENCY:	Mid
ANTENNA POLARIZATION:	Vertical and Horizontal
TEST DISTANCE:	3 m

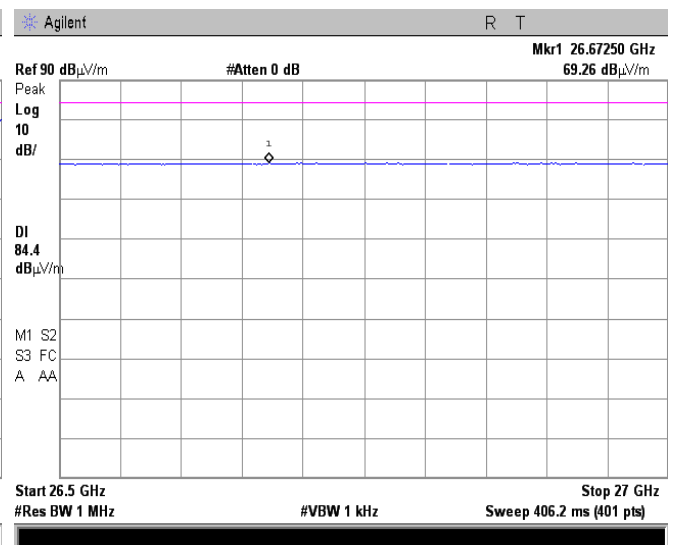
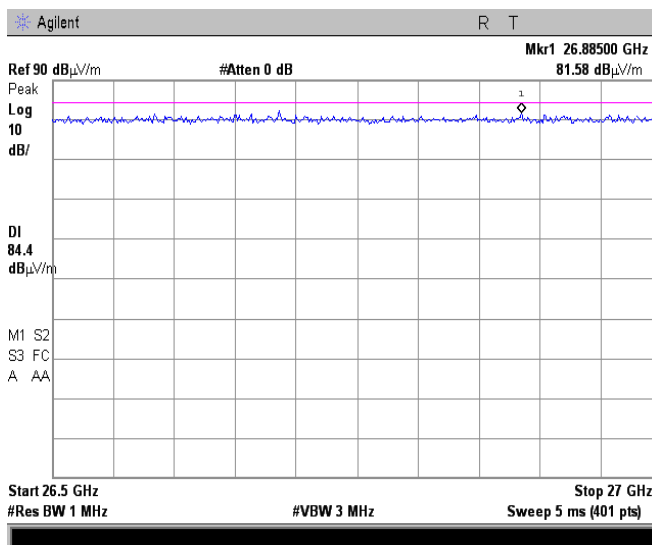



HERMON LABORATORIES

Test specification:		Section 27.53(m)(2), Radiated spurious emissions	
Test procedure:		47 CFR, Sections 2.1053; TIA/EIA-603-D, Section 2.2.12	
Test mode:		Verdict:	
Compliance		PASS	
Date(s):		26-Jul-15	
Temperature: 23 °C	Air Pressure: 10007 hPa	Relative Humidity: 49 %	Power Supply: 48 VDC
Remarks:			

Plot 7.5.21 Radiated emission measurements in 26500 – 27000 MHz range

TEST SITE:
CARRIER FREQUENCY:
ANTENNA POLARIZATION:
TEST DISTANCE:

OATS
High
Vertical and Horizontal
3 m

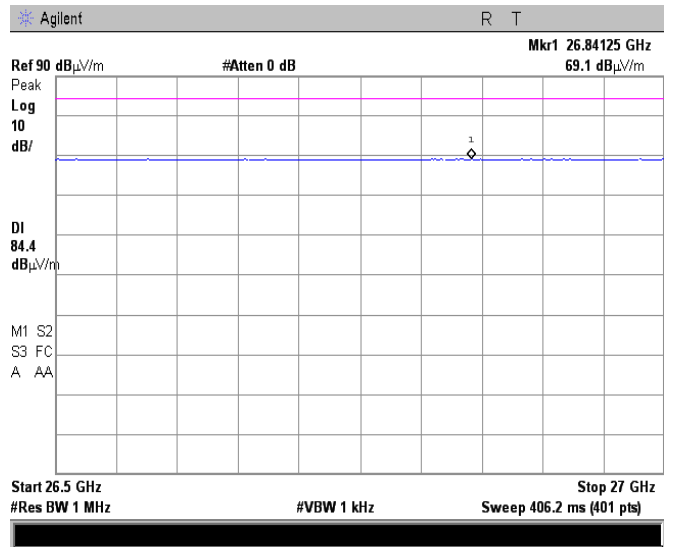
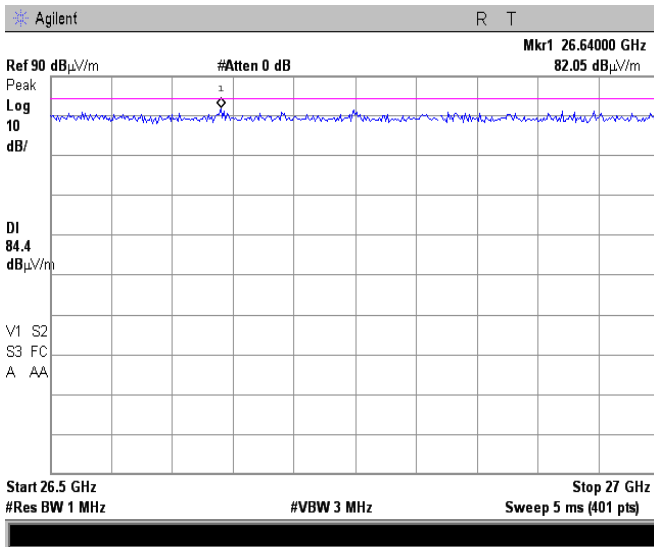



Test specification:		Section 27.54, Frequency stability	
Test procedure:		47 CFR, Section 2.1055; TIA/EIA-603-D Section 2.2.2	
Test mode:		Compliance	
Date(s):		02-Aug-15 - 03-Aug-15	
Temperature: 23 °C		Air Pressure: 1005 hPa	
Remarks:		Verdict: PASS	
		Relative Humidity: 49 %	
		Power Supply: 48 VDC	

7.6 Frequency stability test

7.6.1 General

This test was performed to measure frequency stability of transmitter RF carrier. Specification test limits are given in Table 7.6.1.

Table 7.6.1 Frequency stability limits

Assigned frequency, MHz	Maximum allowed frequency displacement
2496.0 – 2690.0	The frequency stability shall be sufficient to ensure that the fundamental emissions stay within the authorized bands of operation.

7.6.2 Test procedure

- 7.6.2.1 The EUT was set up as shown in Figure 7.6.1, energized and its proper operation was checked.
- 7.6.2.2 The EUT power was turned off. Temperature within test chamber was set to +30°C and a period of time sufficient to stabilize all of the oscillator circuit components was allowed.
- 7.6.2.3 The EUT was powered on and carrier frequency was measured at start up moment and then every minute until frequency had been stabilized or 10 minutes elapsed whichever reached the last. The EUT was powered off.
- 7.6.2.4 The above procedure was repeated at 0°C and at the lowest test temperature.
- 7.6.2.5 The EUT was powered on and carrier frequency was measured at start up moment and at the end of stabilization period at the rest of test temperatures and voltages. The EUT was powered off.
- 7.6.2.6 Frequency displacement was calculated and provided in Table 7.6.2, Table 7.6.3.

Figure 7.6.1 Frequency stability test setup

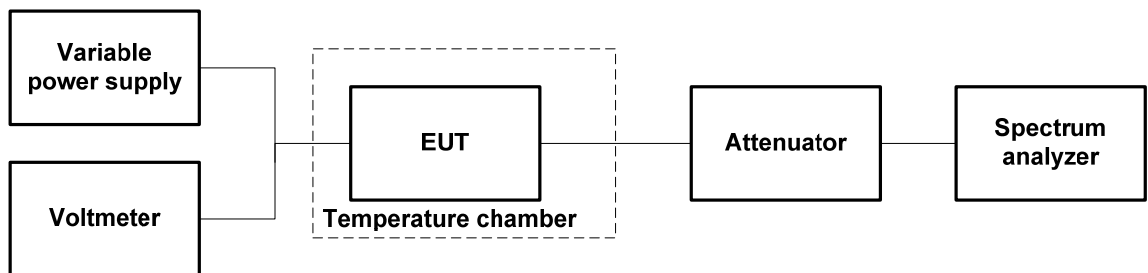

Photograph 7.6.1 Frequency stability test setup



Test specification:		Section 27.54, Frequency stability			
Test procedure:		47 CFR, Section 2.1055; TIA/EIA-603-D Section 2.2.2			
Test mode:		Compliance		Verdict: PASS	
Date(s):		02-Aug-15 - 03-Aug-15			
Temperature: 23 °C		Air Pressure: 1005 hPa		Relative Humidity: 49 %	
Remarks:		Power Supply: 48 VDC			

Table 7.6.2 Frequency stability test results

OPERATING FREQUENCY: 2496 – 2690 MHz
 NOMINAL POWER VOLTAGE: 48 VDC
 TEMPERATURE STABILIZATION PERIOD: 20 min
 POWER DURING TEMPERATURE TRANSITION: Off
 SPECTRUM ANALYZER MODE: Peak Hold
 RESOLUTION BANDWIDTH: 100 Hz
 VIDEO BANDWIDTH: 300 Hz

T, °C	Voltage, V	Frequency, MHz							Max frequency drift, Hz	
		Start up	1 st min	2 nd min	3 rd min	4 th min	5 th min	10 th min	Positive	Negative
Low carrier frequency 2498.50 MHz										
-30	nominal	2498.500691	2498.500667	2498.500633	2498.500591	2498.500573	2498.500573	2498.500587	0.00	-127.00
-20	nominal	2498.500613	NA	NA	NA	NA	NA	2498.500624	0.00	-87.00
-10	nominal	2498.500529	NA	NA	NA	NA	NA	2498.500417	0.00	-283.00
0	nominal	2498.500633	2498.500559	2498.500551	2498.500549	2498.500548	2498.500547	2498.500559	0.00	-153.00
10	nominal	2498.500642	NA	NA	NA	NA	NA	2498.500642	0.00	-58.00
20	15%	2498.500630	NA	NA	NA	NA	NA	2498.500637	0.00	-70.00
20	nominal	2498.500675	NA	NA	NA	NA	NA	2498.500700	0.00	-25.00
20	-15%	2498.500630	NA	NA	NA	NA	NA	2498.500629	0.00	-71.00
30	nominal	2498.500669	2498.500666	2498.500663	2498.500658	2498.500654	2498.500649	2498.500523	0.00	-177.00
40	nominal	2498.500662	NA	NA	NA	NA	NA	2498.500367	0.00	-333.00
50	nominal	2498.500438	2498.500422	2498.500403	2498.500388	2498.500376	2498.500362	2498.500208	0.00	-492.00
Mid carrier frequency 2575.00 MHz										
-30	nominal	2575.000725	2575.000669	2575.000630	2575.000596	2575.000595	2575.000597	2575.000617	68.00	-62.00
-20	nominal	2575.000764	NA	NA	NA	NA	NA	2575.000647	107.00	-10.00
-10	nominal	2575.000530	NA	NA	NA	NA	NA	2575.000440	0.00	-217.00
0	nominal	2575.000584	2575.000588	2575.000591	2575.000592	2575.000594	2575.000595	2575.000602	0.00	-73.00
10	nominal	2575.000673	NA	NA	NA	NA	NA	2575.000669	16.00	0.00
20	15%	2575.000662	NA	NA	NA	NA	NA	2575.000659	5.00	0.00
20	nominal	2575.000700	NA	NA	NA	NA	NA	2575.000657*	43.00	0.00
20	-15%	2575.000656	NA	NA	NA	NA	NA	2575.000655	0.00	-2.00
30	nominal	2575.000543	2575.000542	2575.000541	2575.000541	2575.000540	2575.000539	2575.000536	0.00	-121.00
40	nominal	2575.000385	NA	NA	NA	NA	NA	2575.000366	0.00	-291.00
50	nominal	2575.000331	2575.000328	2575.000323	2575.000317	2575.000314	2575.000311	2575.000213	0.00	-444.00
High carrier frequency 2687.5 MHz										
-30	nominal	2687.500739	2687.500735	2687.500724	2687.500709	2687.500684	2687.500653	2687.500637	57.00	-45.00
-20	nominal	2687.500671	NA	NA	NA	NA	NA	2687.500684	2.00	-11.00
-10	nominal	2687.500466	NA	NA	NA	NA	NA	2687.500483	0.00	-216.00
0	nominal	2687.500692	2687.500692	2687.500692	2687.500692	2687.500693	2687.500697	2687.500701	19.00	0.00
10	nominal	2687.500713	NA	NA	NA	NA	NA	2687.500701	31.00	0.00
20	15%	2687.500685	NA	NA	NA	NA	NA	2687.500681	3.00	-1.00
20	nominal	2687.500685	NA	NA	NA	NA	NA	2687.500682*	3.00	0.00
20	-15%	2687.500680	NA	NA	NA	NA	NA	2687.500681	0.00	-2.00
30	nominal	2687.500655	2687.500647	2687.500639	2687.500630	2687.500628	2687.500624	2687.500590	0.00	-92.00
40	nominal	2687.500387	NA	NA	NA	NA	NA	2687.500369	0.00	-313.00
50	nominal	2687.500220	2687.500216	2687.500213	2687.500209	2687.500205	2687.500203	2687.500188	0.00	-494.00

* - Reference frequency



Test specification:		Section 27.54, Frequency stability	
Test procedure:		47 CFR, Section 2.1055; TIA/EIA-603-D Section 2.2.2	
Test mode:		Compliance	
Date(s):		02-Aug-15 - 03-Aug-15	
Temperature: 23 °C		Air Pressure: 1005 hPa	
Remarks:		Relative Humidity: 49 %	
		Power Supply: 48 VDC	
Verdict: PASS			

Table 7.6.3 Maximum frequency displacement

Channel	Maximum frequency displacement			
	ppm		Hz	
	Negative	Positive	Negative	Positive
Low	0.00	-1.23	0.00	-492.00
High	0.28	-1.15	107.00	-444.00

Table 7.6.4 Transmission occupied bandwidth with frequency drift test results

Lower measured* band edge, MHz	Upper measured* band edge, MHz	Lower calculated** band edge, MHz	Upper calculated** band edge, MHz	Lower specified band edge, MHz	Upper specified band edge, MHz	Lower margin***, MHz	Upper margin***, MHz	Verdict
5 MHz BW								
QPSK								
2496.059	2500.936	2496.059	2500.936	2496.0	2502.0	-0.059	-1.064	Pass
2572.589	2577.436	2572.589	2577.436	2572.0	2578.0	-0.589	-0.564	Pass
2685.059	2689.936	2685.059	2689.936	2684.5	2690.0	-0.559	-0.064	Pass
64QAM								
2496.024	2501.006	2496.024	2501.006	2496.0	2502.0	-0.024	-0.994	Pass
2572.240	2577.750	2572.240	2577.750	2572.0	2578.0	-0.240	-0.250	Pass
2684.969	2689.971	2684.969	2689.971	2684.5	2690.0	-0.469	-0.029	Pass
10 MHz BW								
QPSK								
2496.085	2506.004	2496.085	2506.004	2496.0	2507.5	-0.085	-1.496	Pass
2590.980	2601.079	2590.980	2601.079	2590.0	2602.0	-0.980	-0.921	Pass
2680.093	2689.862	2680.093	2689.862	2679.0	2690.0	-1.093	-0.138	Pass
64QAM								
2496.011	2506.087	2496.011	2506.087	2496.0	2507.5	-0.011	-1.413	Pass
2591.093	2601.087	2591.093	2601.087	2590.0	2602.0	-1.093	-0.913	Pass
2680.183	2689.996	2680.183	2689.996	2679.0	2690.0	-1.183	-0.004	Pass

* - Measured under normal test conditions at 26 dBc points
 ** - Measured band edge with proper drift addition
 *** - Margin = Calculated band edge – specified band edge

Reference numbers of test equipment used

HL 3286	HL 3301	HL 3302	HL 3667	HL 3818	HL 4293		
---------	---------	---------	---------	---------	---------	--	--

Full description is given in Appendix A.



HERMON LABORATORIES

Test specification:		Section 27.54, Frequency stability	
Test procedure:		47 CFR, Section 2.1055; TIA/EIA-603-D Section 2.2.2	
Test mode:		Compliance	
Date(s):		02-Aug-15 - 03-Aug-15	
Temperature: 23 °C		Air Pressure: 1005 hPa	
		Relative Humidity: 49 %	
		Power Supply: 48 VDC	
Remarks:			
		Verdict: PASS	

Plot 7.6.1 Emission mask test results at low carrier frequency, 5 MHz EBW

OPERATING FREQUENCY RANGE: 2496.0 – 2690.0 MHz
DETECTOR USED: Average
MODULATION: QPSK
MODULATING SIGNAL: PRBS
TRANSMITTER OUTPUT POWER SETTINGS: Maximum

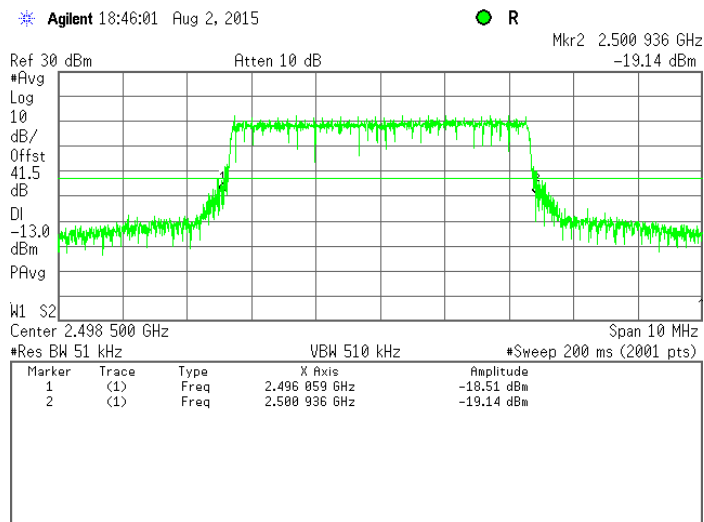

Plot 7.6.2 Emission mask test results at mid carrier frequency, 5 MHz EBW

OPERATING FREQUENCY RANGE: 2496.0 – 2690.0 MHz
DETECTOR USED: Average
MODULATION: QPSK
MODULATING SIGNAL: PRBS
TRANSMITTER OUTPUT POWER SETTINGS: Maximum

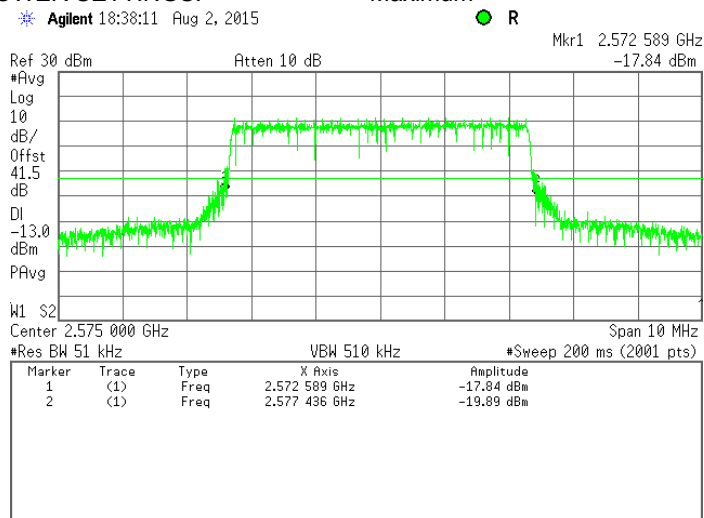



Test specification: Section 27.54, Frequency stability			
Test procedure: 47 CFR, Section 2.1055; TIA/EIA-603-D Section 2.2.2			
Test mode: Compliance	Verdict: PASS		
Date(s): 02-Aug-15 - 03-Aug-15			
Temperature: 23 °C	Air Pressure: 1005 hPa	Relative Humidity: 49 %	Power Supply: 48 VDC
Remarks:			

Plot 7.6.3 Emission mask test results at high carrier frequency, 5 MHz EBW

OPERATING FREQUENCY RANGE: 2496.0 – 2690.0 MHz
DETECTOR USED: Average
MODULATION: QPSK
MODULATING SIGNAL: PRBS
TRANSMITTER OUTPUT POWER SETTINGS: Maximum

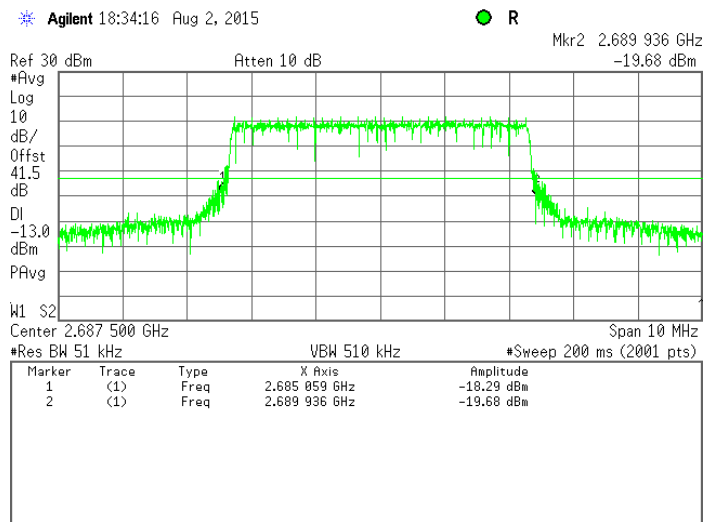

Plot 7.6.4 Emission mask test results at low carrier frequency, 5 MHz EBW

OPERATING FREQUENCY RANGE: 2496.0 – 2690.0 MHz
DETECTOR USED: Average
MODULATION: 64QAM
MODULATING SIGNAL: PRBS
TRANSMITTER OUTPUT POWER SETTINGS: Maximum

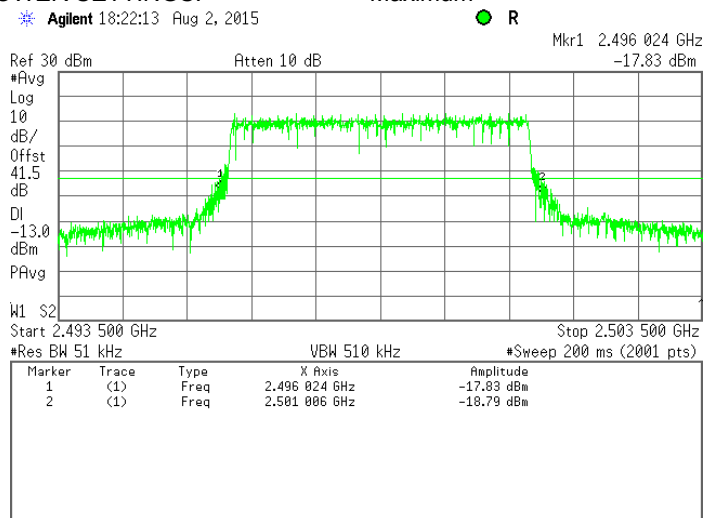



HERMON LABORATORIES

Test specification:		Section 27.54, Frequency stability	
Test procedure:		47 CFR, Section 2.1055; TIA/EIA-603-D Section 2.2.2	
Test mode:		Compliance	
Date(s):		02-Aug-15 - 03-Aug-15	
Temperature: 23 °C		Air Pressure: 1005 hPa	
Relative Humidity: 49 %		Power Supply: 48 VDC	
Remarks:			
		Verdict: PASS	

Plot 7.6.5 Emission mask test results at mid carrier frequency, 5 MHz EBW

OPERATING FREQUENCY RANGE: 2496.0 – 2690.0 MHz
DETECTOR USED: Average
MODULATION: 64QAM
MODULATING SIGNAL: PRBS
TRANSMITTER OUTPUT POWER SETTINGS: Maximum

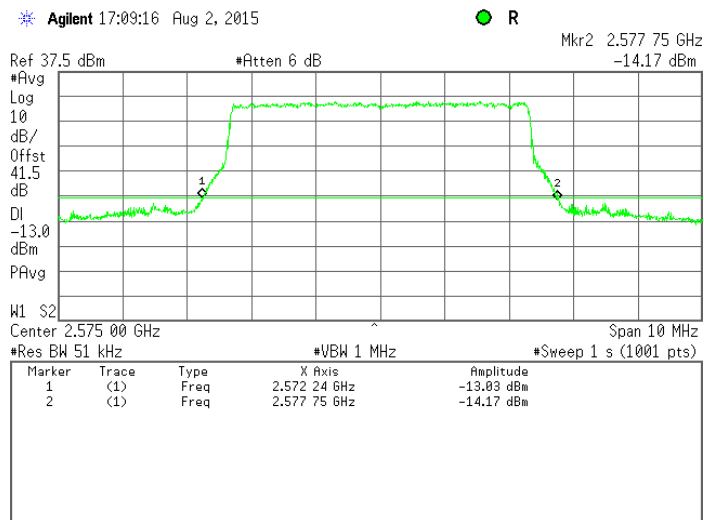

Plot 7.6.6 Emission mask test results at high carrier frequency, 5 MHz EBW

OPERATING FREQUENCY RANGE: 2496.0 – 2690.0 MHz
DETECTOR USED: Average
MODULATION: 64QAM
MODULATING SIGNAL: PRBS
TRANSMITTER OUTPUT POWER SETTINGS: Maximum

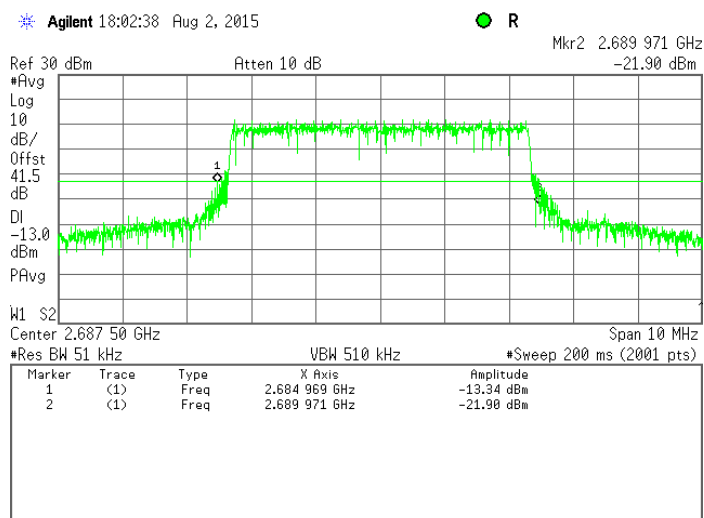



HERMON LABORATORIES

Test specification:		Section 27.54, Frequency stability	
Test procedure:		47 CFR, Section 2.1055; TIA/EIA-603-D Section 2.2.2	
Test mode:		Compliance	
Date(s):		02-Aug-15 - 03-Aug-15	
Temperature: 23 °C		Air Pressure: 1005 hPa	
		Relative Humidity: 49 %	
		Power Supply: 48 VDC	
Remarks:			
		Verdict: PASS	

Plot 7.6.7 Emission mask test results at low carrier frequency, 10 MHz EBW

OPERATING FREQUENCY RANGE: 2496.0 – 2690.0 MHz
DETECTOR USED: Average
MODULATION: QPSK
MODULATING SIGNAL: PRBS
TRANSMITTER OUTPUT POWER SETTINGS: Maximum

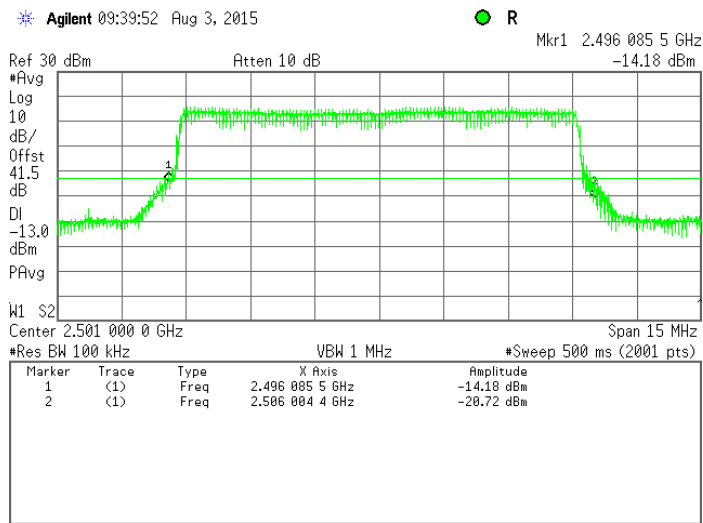

Plot 7.6.8 Emission mask test results at mid carrier frequency, 10 MHz EBW

OPERATING FREQUENCY RANGE: 2496.0 – 2690.0 MHz
DETECTOR USED: Average
MODULATION: QPSK
MODULATING SIGNAL: PRBS
TRANSMITTER OUTPUT POWER SETTINGS: Maximum

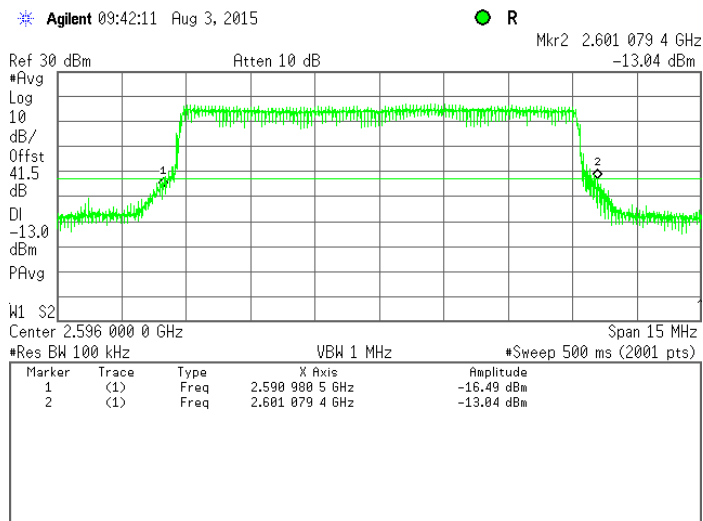



HERMON LABORATORIES

Test specification:		Section 27.54, Frequency stability	
Test procedure:		47 CFR, Section 2.1055; TIA/EIA-603-D Section 2.2.2	
Test mode:		Compliance	
Date(s):		02-Aug-15 - 03-Aug-15	
Temperature: 23 °C		Air Pressure: 1005 hPa	
		Relative Humidity: 49 %	
		Power Supply: 48 VDC	
Remarks:			
		Verdict: PASS	

Plot 7.6.9 Emission mask test results at high carrier frequency, 10 MHz EBW

OPERATING FREQUENCY RANGE: 2496.0 – 2690.0 MHz
DETECTOR USED: Average
MODULATION: QPSK
MODULATING SIGNAL: PRBS
TRANSMITTER OUTPUT POWER SETTINGS: Maximum

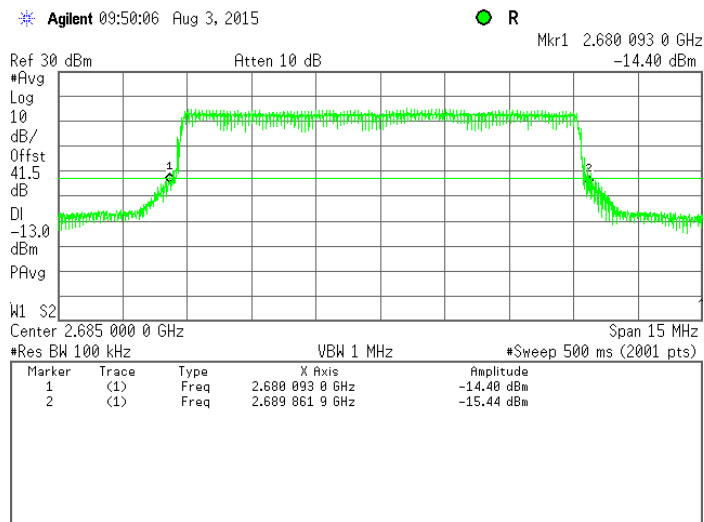

Plot 7.6.10 Emission mask test results at low carrier frequency, 10 MHz EBW

OPERATING FREQUENCY RANGE: 2496.0 – 2690.0 MHz
DETECTOR USED: Average
MODULATION: 64QAM
MODULATING SIGNAL: PRBS
TRANSMITTER OUTPUT POWER SETTINGS: Maximum

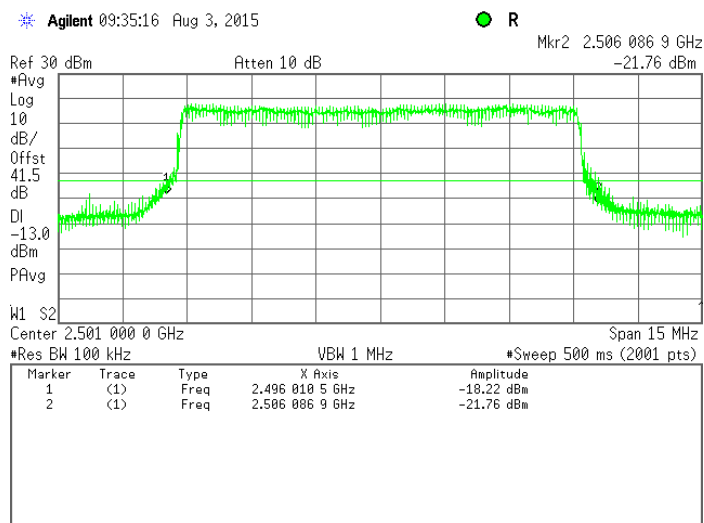



HERMON LABORATORIES

Test specification:		Section 27.54, Frequency stability	
Test procedure:		47 CFR, Section 2.1055; TIA/EIA-603-D Section 2.2.2	
Test mode:		Compliance	
Date(s):		02-Aug-15 - 03-Aug-15	
Temperature: 23 °C		Air Pressure: 1005 hPa	
Relative Humidity: 49 %		Power Supply: 48 VDC	
Remarks:			
		Verdict: PASS	

Plot 7.6.11 Emission mask test results at mid carrier frequency, 10 MHz EBW

OPERATING FREQUENCY RANGE: 2496.0 – 2690.0 MHz
DETECTOR USED: Average
MODULATION: 64QAM
MODULATING SIGNAL: PRBS
TRANSMITTER OUTPUT POWER SETTINGS: Maximum

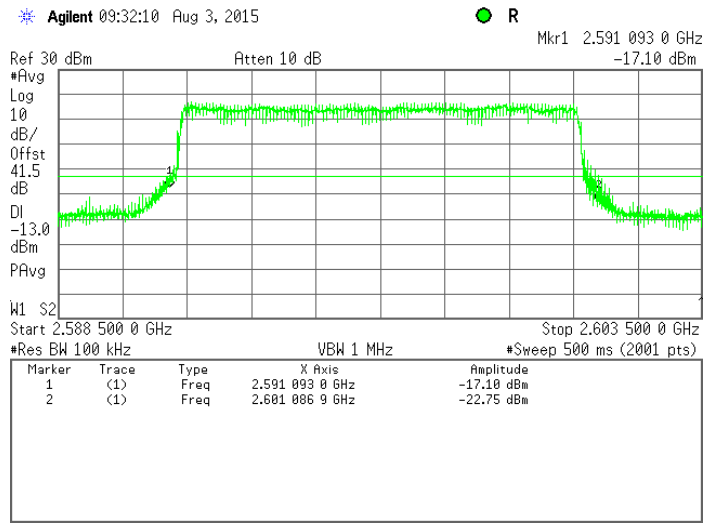

Plot 7.6.12 Emission mask test results at high carrier frequency, 10 MHz EBW

OPERATING FREQUENCY RANGE: 2496.0 – 2690.0 MHz
DETECTOR USED: Average
MODULATION: 64QAM
MODULATING SIGNAL: PRBS
TRANSMITTER OUTPUT POWER SETTINGS: Maximum

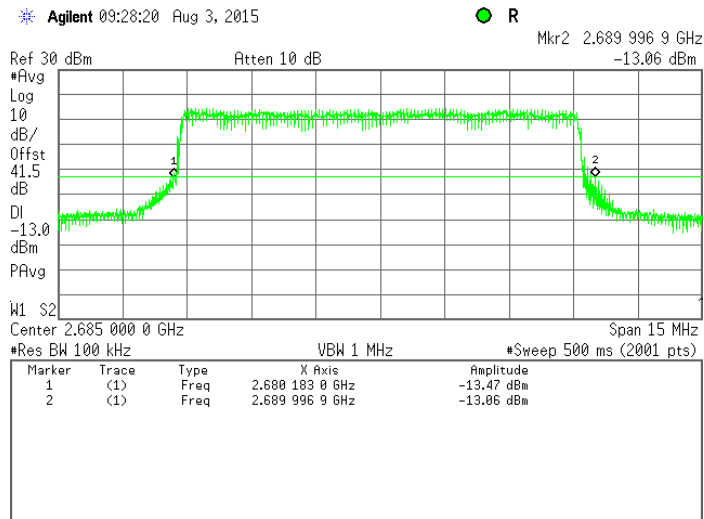

**8 APPENDIX A Test equipment and ancillaries used for tests**

HL No	Description	Manufacturer	Model	Ser. No.	Last Cal./ Check	Due Cal./ Check
0446	Antenna, Loop, Active, 10 kHz - 30 MHz	EMCO	6502	2857	13-Jan-15	13-Jan-16
0521	EMI Receiver (Spectrum Analyzer) with RF filter section 9 kHz-6.5 GHz	Hewlett Packard	8546A	3617A 00319, 3448A002 53	22-Oct-14	22-Oct-15
0604	Antenna BiconiLog Log-Periodic/T Bow-TIE, 26 - 2000 MHz	EMCO	3141	9611-1011	15-May-15	15-May-16
0768	Antenna Standard Gain Horn, 18-26.5 GHz, WR-42, 25 dB gain	Quinstar Technology	QWH-4200-BA	110	25-Dec-14	25-Dec-15
0769	Antenna Standard Gain Horn, 26.5-40 GHz, WR28, 25 dB gain	Quinstar Technology	QWH-2800-BA	112	25-Dec-14	25-Dec-15
1984	Antenna, Double-Ridged Waveguide Horn, 1-18 GHz, 300 W	EMC Test Systems	3115	9911-5964	17-Apr-15	17-Apr-16
2780	EMC analyzer, 100 Hz to 26.5 GHz	Agilent Technologies	E7405A	MY451024 62	02-Sep-14	02-Sep-15
2871	Microwave Cable Assembly, 18 GHz, 6.4 m, SMA - SMA	Huber-Suhner	198-8155-00	2871	02-Dec-14	02-Dec-15
3286	Temperature Chamber, (-40 to +170) °C	Thermotron	EL-8-CH-1-1-CO2	21-9048	09-Sep-14	09-Sep-15
3301	Power Meter, P-series, 50 MHz to 40 GHz	Agilent Technologies	N1911A	MY451010 57	30-Jan-15	30-Jan-16
3302	Power sensor, P-Series, 50 MHz to 40 GHz, -35/30 to 20 dBm	Agilent Technologies	N1922A	MY452405 86	30-Jan-15	30-Jan-16
3535	Amplifier, low noise, 18 to 40 GHz	Quinstar Technology	QLJ-18404537-J0	111590030 01	30-Dec-14	30-Dec-15
3667	Directional coupler, 2 GHz to 8 GHz, 10 dB	ELISRA	MW10162	1011	11-Jun-15	11-Jun-17
3818	PSA Series Spectrum Analyzer, 3 Hz- 44 GHz	Agilent Technologies	E4446A	MY482502 88	29-Apr-15	29-Apr-16
3901	Microwave Cable Assembly, 40.0 GHz, 3.5 m, SMA/SMA	Huber-Suhner	SUCOFLEX 102A	1225/2A	10-Feb-15	10-Feb-16
4114	Antenna, Double-Ridged Waveguide Horn, 1-18 GHz	ETS Lindgren	3117	00123515	19-Dec-14	19-Dec-15
4150	Preamplifier, 0.1 to 18 GHz, Gain 25 dB, N-type(f) in, N-type(m) out.	Agilent Technologies	87405C	MY470105 91	30-Dec-14	30-Dec-15
4293	Microwave Cable Assembly, 18.0 GHz, 3.4 m, SMA/SMA	Huber-Suhner	Sucoflex P103	NA	02-Dec-14	02-Dec-15
4353	Low Loss Armored Test Cable, DC - 18 GHz, 6.2 m, N type-M/N type-M	MegaPhase	NC29-N1N1-244	12025101 003	15-Mar-15	15-Mar-16



9 APPENDIX B Measurement uncertainties

Expanded uncertainty at 95% confidence in Hermon Labs EMC measurements

Test description	Expanded uncertainty
Transmitter tests	
Carrier power conducted at antenna connector	± 1.7 dB
Carrier power radiated (substitution method)	± 4.5 dB
Occupied bandwidth	±8%
Conducted emissions at RF antenna connector	9 kHz to 2.9 GHz: ± 2.6 dB 2.9 GHz to 6.46 GHz: ± 3.5 dB 6.46 GHz to 13.2 GHz: ± 4.3 dB 13.2 GHz to 22.0 GHz: ± 5.0 dB 22.0 GHz to 26.8 GHz: ± 5.5 dB 26.8 GHz to 40.0 GHz: ± 4.8 dB
Spurious emissions radiated 30 MHz – 40 GHz (substitution method)	± 4.5 dB
Frequency error	30 – 300 MHz: ± 50.5 Hz (1.68 ppm) 300 – 1000 MHz: ± 168 Hz (0.56 ppm)
Transient frequency behaviour	187 Hz ± 13.9 %
Duty cycle, timing (Tx ON / OFF) and average factor measurements	± 1.0 %
Unintentional radiator tests	
Conducted emissions with LISN	9 kHz to 150 kHz: ± 3.9 dB 150 kHz to 30 MHz: ± 3.8 dB
Radiated emissions at 3 m measuring distance Horizontal polarization	Biconilog antenna: ± 5.3 dB Biconical antenna: ± 5.0 dB Log periodic antenna: ± 5.3 dB Double ridged horn antenna: ± 5.3 dB
Vertical polarization	Biconilog antenna: ± 6.0 dB Biconical antenna: ± 5.7 dB Log periodic antenna: ± 6.0 dB Double ridged horn antenna: ± 6.0 dB

Hermon Laboratories is accredited by A2LA for calibration according to present requirements of ISO/IEC 17025 and NCSL Z540-1. The accreditation is granted to perform calibration of parameters that are listed in the Scope of Hermon Laboratories Accreditation.

Hermon Laboratories calibrates its reference and transfer standards by calibration laboratories accredited to ISO/IEC 17025 by a mutually recognized Accreditation Body or by a recognized national metrology institute. All reference and transfer standards used in the calibration system are traceable to national or international standards.

In-house calibration of all test and measurement equipment is performed on a regular basis according to Hermon Laboratories calibration procedures, manufacturer calibration/verification procedures or procedures defined in the relevant standards. The Hermon Laboratories test and measurement equipment is calibrated within the tolerances specified by the manufacturers and/or by the relevant standards.

10 APPENDIX C Test facility description

Tests were performed at Hermon Laboratories Ltd., which is a fully independent, private, EMC, safety, environmental and telecommunication testing facility.

Hermon Laboratories is listed by the Federal Communications Commission (USA) for all parts of Code of Federal Regulations 47 (CFR 47), Registration Numbers 90624 for OATS and 90623 for the anechoic chamber; by Industry Canada for electromagnetic emissions (file numbers IC 2186A-1 for OATS), certified by VCCI, Japan (the registration numbers are R-808 for OATS, R-1082 for anechoic chamber, G-27 for full-anechoic chamber for RE measurements above 1 GHz, C-845 for conducted emissions site, T-1606 for conducted emissions at telecommunication ports), has a status of a Telefication - Listed Testing Laboratory, Certificate No. L138/00. The laboratory is accredited by American Association for Laboratory Accreditation (USA) according to ISO/IEC 17025 for electromagnetic compatibility, product safety, telecommunications testing and environmental simulation (for exact scope please refer to Certificate No. 839.01). The FCC Designation Number is US1003.

Address: P.O. Box 23, Binyamina 30500, Israel.
Telephone: +972 4628 8001
Fax: +972 4628 8277
e-mail: mail@hermonlabs.com
website: www.hermonlabs.com

Person for contact: Mr. Alex Usoskin, CEO.

11 APPENDIX D Specification references

47CFR part 27: 2014	Private land mobile radio services
47CFR part 1: 2014	Practice and procedure
47CFR part 2: 2014	Frequency allocations and radio treaty matters; general rules and regulations
ANSI C63.2: 1996	American National Standard for Instrumentation-Electromagnetic Noise and Field Strength, 10 kHz to 40 GHz-Specifications.
ANSI C63.4: 2003	American National Standard for Methods of Measurement of Radio-Noise Emissions from Low-Voltage Electrical and Electronic Equipment in the Range of 9 kHz to 40 GHz.
ANSI/TIA/EIA-603-D:2010	Land Mobile FM or PM Communications Equipment Measurement and Performance Standards



13 APPENDIX E Test equipment correction factors

Antenna factor
Active loop antenna
Model 6502, S/N 2857, HL 0446

Frequency, MHz	Magnetic antenna factor, dB	Electric antenna factor, dB
0.009	-32.8	18.7
0.010	-33.8	17.7
0.020	-38.3	13.2
0.050	-41.1	10.4
0.075	-41.3	10.2
0.100	-41.6	9.9
0.150	-41.7	9.8
0.250	-41.6	9.9
0.500	-41.8	9.8
0.750	-41.9	9.7
1.000	-41.4	10.1
2.000	-41.5	10.0
3.000	-41.4	10.2
4.000	-41.4	10.1
5.000	-41.5	10.1
10.000	-41.9	9.6
15.000	-41.9	9.6
20.000	-42.2	9.3
25.000	-42.8	8.7
30.000	-44.0	7.5

Antenna factor in dB(1/m) is to be added to receiver meter reading in dB(μV) to convert it into field strength in dB(μV/m).

Antenna factor
Standard gain horn antenna
Quinstar Technology
Model QWH
Ser.No.112, HL 0768, 0769, 0770, 0771, 0772

Frequency min, GHz	Frequency max, GHz	Antenna factor, dB(1/m)
18.000	26.500	32.01
26.500	40.000	35.48
40.000	60.000	39.03
60.000	90.000	42.55
90.000	140.000	46.23
140.000	220.000	50.11

Antenna factor in dB(1/m) is to be added to receiver meter reading in dB(μV) to convert it into field strength in dB(μV/m).



Antenna factor
Biconilog antenna EMCO Model 3141
Ser.No.1011, HL 0604

Frequency, MHz	Antenna factor, dB(1/m)	Frequency, MHz	Antenna factor, dB(1/m)	Frequency, MHz	Antenna factor, dB(1/m)
26	7.8	580	20.6	1320	27.8
28	7.8	600	21.3	1340	28.3
30	7.8	620	21.5	1360	28.2
40	7.2	640	21.2	1380	27.9
60	7.1	660	21.4	1400	27.9
70	8.5	680	21.9	1420	27.9
80	9.4	700	22.2	1440	27.8
90	9.8	720	22.2	1460	27.8
100	9.7	740	22.1	1480	28.0
110	9.3	760	22.3	1500	28.5
120	8.8	780	22.6	1520	28.9
130	8.7	800	22.7	1540	29.6
140	9.2	820	22.9	1560	29.8
150	9.8	840	23.1	1580	29.6
160	10.2	860	23.4	1600	29.5
170	10.4	880	23.8	1620	29.3
180	10.4	900	24.1	1640	29.2
190	10.3	920	24.1	1660	29.4
200	10.6	940	24.0	1680	29.6
220	11.6	960	24.1	1700	29.8
240	12.4	980	24.5	1720	30.3
260	12.8	1000	24.9	1740	30.8
280	13.7	1020	25.0	1760	31.1
300	14.7	1040	25.2	1780	31.0
320	15.2	1060	25.4	1800	30.9
340	15.4	1080	25.6	1820	30.7
360	16.1	1100	25.7	1840	30.6
380	16.4	1120	26.0	1860	30.6
400	16.6	1140	26.4	1880	30.6
420	16.7	1160	27.0	1900	30.6
440	17.0	1180	27.0	1920	30.7
460	17.7	1200	26.7	1940	30.9
480	18.1	1220	26.5	1960	31.2
500	18.5	1240	26.5	1980	31.6
520	19.1	1260	26.5	2000	32.0
540	19.5	1280	26.6		
560	19.8	1300	27.0		

Antenna factor in dB(1/m) is to be added to receiver meter reading in dB(μ V) to convert it into field strength in dB(μ V/m).



Antenna factor
Double-ridged wave guide horn antenna
Model 3115, S/N 9911-5964, HL1984

Frequency, MHz	Antenna factor, dB(1/m)
1000.0	24.7
1500.0	25.7
2000.0	27.6
2500.0	28.9
3000.0	31.2
3500.0	32.0
4000.0	32.5
4500.0	32.7
5000.0	33.6
5500.0	35.1
6000.0	35.4
6500.0	34.9
7000.0	36.1
7500.0	37.8
8000.0	38.0
8500.0	38.1
9000.0	39.1
9500.0	38.3
10000.0	38.6
10500.0	38.2
11000.0	38.7
11500.0	39.5
12000.0	40.0
12500.0	40.4
13000.0	40.5
13500.0	41.1
14000.0	41.6
14500.0	41.7
15000.0	38.7
15500.0	38.2
16000.0	38.8
16500.0	40.5
17000.0	42.5
17500.0	45.9
18000.0	49.4

Antenna factor in dB(1/m) is to be added to receiver meter reading in dB(μ V) to convert it into field strength in dB(μ V/m).



Antenna factor
Double-ridged waveguide horn antenna
ETS Lindgren, Model 3117, serial number: 00123515, HL 4114

Frequency, MHz	Antenna factor, dB/m		
	Measured	Manufacturer	Deviation
1000	28.0	28.4	-0.4
1500	28.0	27.4	0.6
2000	31.2	30.9	0.3
2500	32.5	33.4	-0.9
3000	32.9	32.6	0.3
3500	32.7	32.8	-0.1
4000	33.1	33.4	-0.3
4500	33.8	33.9	-0.1
5000	33.8	34.1	-0.3
5500	34.4	34.5	-0.1
6000	35.0	35.2	-0.2
6500	35.4	35.5	-0.1
7000	35.7	35.7	0.0
7500	35.9	35.7	0.2
8000	35.8	35.8	0.0
8500	35.9	35.8	0.1
9000	36.3	36.2	0.1
9500	36.6	36.6	0.0
10000	37.1	37.1	0.0
10500	37.6	37.5	0.1
11000	37.9	37.7	0.2
11500	38.5	38.1	0.4
12000	39.2	38.7	0.5
12500	39.0	38.9	0.1
13000	39.1	39.1	0.0
13500	38.9	38.8	0.1
14000	39.0	38.8	0.2
14500	39.6	39.9	-0.3
15000	39.9	39.7	0.2
15500	39.9	40.1	-0.2
16000	40.7	40.8	-0.1
16500	41.3	41.8	-0.5
17000	42.5	42.1	0.4
17500	41.3	41.2	0.1
18000	41.4	40.9	0.5

Antenna factor is to be added to receiver meter reading in dB(μ V) to convert to field strength in dB(μ V/meter)



Cable loss
Cable coaxial, Huber-Suhner, 18 GHz, 6.4 m, SMA - SMA, model 198-8155-00,
HL 2871

Frequency, MHz	Cable loss, dB	Frequency, MHz	Cable loss, dB	Frequency, MHz	Cable loss, dB
10	0.12	5750	2.34	12000	3.55
30	0.14	6000	2.39	12250	3.61
100	0.27	6250	2.46	12500	3.67
250	0.45	6500	2.52	12750	3.74
500	0.63	6750	2.58	13000	3.79
750	0.76	7000	2.64	13250	3.82
1000	0.89	7250	2.68	13500	3.83
1250	1.01	7500	2.73	13750	3.83
1500	1.12	7750	2.78	14000	3.88
1750	1.23	8000	2.83	14250	3.93
2000	1.32	8250	2.88	14500	3.96
2250	1.41	8500	2.94	14750	4.01
2500	1.49	8750	2.97	15000	4.00
2750	1.58	9000	3.02	15250	4.01
3000	1.66	9250	3.07	15500	4.00
3250	1.73	9500	3.13	15750	4.13
3500	1.80	9750	3.18	16000	4.22
3750	1.87	10000	3.21	16250	4.29
4000	1.93	10250	3.26	16500	4.29
4250	2.01	10500	3.30	16750	4.32
4500	2.06	10750	3.36	17000	4.37
4750	2.12	11000	3.39	17250	4.45
5000	2.17	11250	3.44	17500	4.49
5250	2.24	11500	3.48	17750	4.53
5500	2.29	11750	3.52	18000	4.55



Cable loss
Microwave Cable Assembly, Huber-Suhner, 40 GHz, 3.5 m, SMA-SMA, S/N 1225/2A
HL 3901

Frequency, MHz	Cable loss, dB	Frequency, MHz	Cable loss, dB	Frequency, MHz	Cable loss, dB
10	0.09	9500	4.29	21000	6.67
100	0.41	10000	4.40	22000	6.92
500	0.93	10500	4.52	23000	7.00
1000	1.33	11000	4.64	24000	7.18
1500	1.63	11500	4.76	25000	7.29
2000	1.90	12000	4.87	26000	7.55
2500	2.12	12500	4.99	27000	7.70
3000	2.33	13000	5.11	28000	7.88
3500	2.50	13500	5.20	29000	8.02
4000	2.67	14000	5.31	30000	8.15
4500	2.82	14500	5.42	31000	8.35
5000	2.99	15000	5.51	32000	8.40
5500	3.16	15500	5.58	33000	8.62
6000	3.32	16000	5.68	34000	8.73
6500	3.51	16500	5.78	35000	8.78
7000	3.65	17000	5.91	36000	8.94
7500	3.79	17500	5.99	37000	9.21
8000	3.92	18000	6.07	38000	9.37
8500	4.04	19000	6.36	39000	9.45
9000	4.18	20000	6.49	40000	9.52



Cable loss
Microwave Cable Assembly, 18.0 GHz, 3.4 m, SMA/SMA, Huber-Suhner,
Sucoflex P103, HL 4293

Frequency, MHz	Cable loss, dB	Frequency, MHz	Cable loss, dB	Frequency, MHz	Cable loss, dB	Frequency, MHz	Cable loss, dB
50	0.20	4900	2.01	9800	2.94	14700	3.85
100	0.28	5000	2.03	9900	2.95	14800	3.87
200	0.39	5100	2.06	10000	2.98	14900	3.89
300	0.48	5200	2.08	10100	3.01	15000	3.94
400	0.55	5300	2.07	10200	3.04	15100	3.94
500	0.61	5400	2.12	10300	3.04	15200	3.91
600	0.68	5500	2.12	10400	3.04	15300	3.93
700	0.73	5600	2.16	10500	3.07	15400	3.94
800	0.78	5700	2.16	10600	3.10	15500	3.96
900	0.83	5800	2.22	10700	3.11	15600	3.96
1000	0.88	5900	2.24	10800	3.12	15700	3.97
1100	0.92	6000	2.28	10900	3.15	15800	4.00
1200	0.96	6100	2.31	11000	3.22	15900	4.01
1300	1.00	6200	2.32	11100	3.20	16000	4.03
1400	1.04	6300	2.34	11200	3.19	16100	4.02
1500	1.07	6400	2.37	11300	3.21	16200	4.05
1600	1.11	6500	2.38	11400	3.26	16300	4.06
1700	1.15	6600	2.38	11500	3.27	16400	4.08
1800	1.19	6700	2.40	11600	3.27	16500	4.07
1900	1.22	6800	2.42	11700	3.28	16600	4.10
2000	1.25	6900	2.43	11800	3.32	16700	4.14
2100	1.28	7000	2.44	11900	3.34	16800	4.12
2200	1.34	7100	2.48	12000	3.34	16900	4.13
2300	1.35	7200	2.46	12100	3.35	17000	4.13
2400	1.39	7300	2.51	12200	3.39	17100	4.19
2500	1.40	7400	2.53	12300	3.44	17200	4.22
2600	1.44	7500	2.50	12400	3.44	17300	4.20
2700	1.47	7600	2.53	12500	3.43	17400	4.21
2800	1.50	7700	2.63	12600	3.45	17500	4.19
2900	1.54	7800	2.62	12700	3.47	17600	4.22
3000	1.56	7900	2.58	12800	3.51	17700	4.24
3100	1.59	8000	2.64	12900	3.51	17800	4.23
3200	1.62	8100	2.66	13000	3.52	17900	4.26
3300	1.64	8200	2.67	13100	3.56	18000	4.27
3400	1.67	8300	2.63	13200	3.57		
3500	1.69	8400	2.64	13300	3.58		
3600	1.72	8500	2.65	13400	3.60		
3700	1.74	8600	2.68	13500	3.61		
3800	1.78	8700	2.72	13600	3.66		
3900	1.80	8800	2.73	13700	3.68		
4000	1.83	8900	2.74	13800	3.67		
4100	1.84	9000	2.77	13900	3.68		
4200	1.86	9100	2.79	14000	3.73		
4300	1.89	9200	2.82	14100	3.74		
4400	1.92	9300	2.81	14200	3.74		
4500	1.94	9400	2.85	14300	3.76		
4600	1.97	9500	2.89	14400	3.78		
4700	1.97	9600	2.90	14500	3.81		
4800	2.01	9700	2.92	14600	3.83		



Cable loss
Low Loss Armored Test Cable, MegaPhase, 18 GHz, 6.2 m, N type-M/N type-M,
NC29-N1N1-244S/N 12025101 003,
HL 4353

Frequency, MHz	Cable loss, dB	Frequency, MHz	Cable loss, dB
50	0.20	9000	2.71
100	0.27	9500	2.81
300	0.47	10000	2.90
500	0.61	10500	2.97
1000	0.87	11000	3.06
1500	1.07	11500	3.13
2000	1.24	12000	3.20
2500	1.39	12500	3.26
3000	1.53	13000	3.34
3500	1.65	13500	3.39
4000	1.77	14000	3.47
4500	1.89	14500	3.54
5000	1.99	15000	3.62
5500	2.07	15500	3.69
6000	2.20	16000	3.76
6500	2.30	16500	3.83
7000	2.39	17000	3.86
7500	2.51	17500	3.94
8000	2.58	18000	4.02
8500	2.65		



14 APPENDIX F Abbreviations and acronyms

A	ampere
AC	alternating current
AM	amplitude modulation
AVRG	average (detector)
BB	broad band
cm	centimeter
dB	decibel
dBm	decibel referred to one milliwatt
dB(μ V)	decibel referred to one microvolt
dB(μ V/m)	decibel referred to one microvolt per meter
dB(μ A)	decibel referred to one microampere
DC	direct current
EIRP	equivalent isotropically radiated power
ERP	effective radiated power
EUT	equipment under test
F	frequency
GHz	gigahertz
GND	ground
H	height
HL	Hermon laboratories
Hz	hertz
k	kilo
kHz	kilohertz
LO	local oscillator
m	meter
MHz	megahertz
min	minute
mm	millimeter
ms	millisecond
μ s	microsecond
NA	not applicable
NB	narrow band
OATS	open area test site
Ω	Ohm
QP	quasi-peak
RE	radiated emission
RF	radio frequency
rms	root mean square
Rx	receive
s	second
T	temperature
Tx	transmit
V	volt

END OF DOCUMENT