

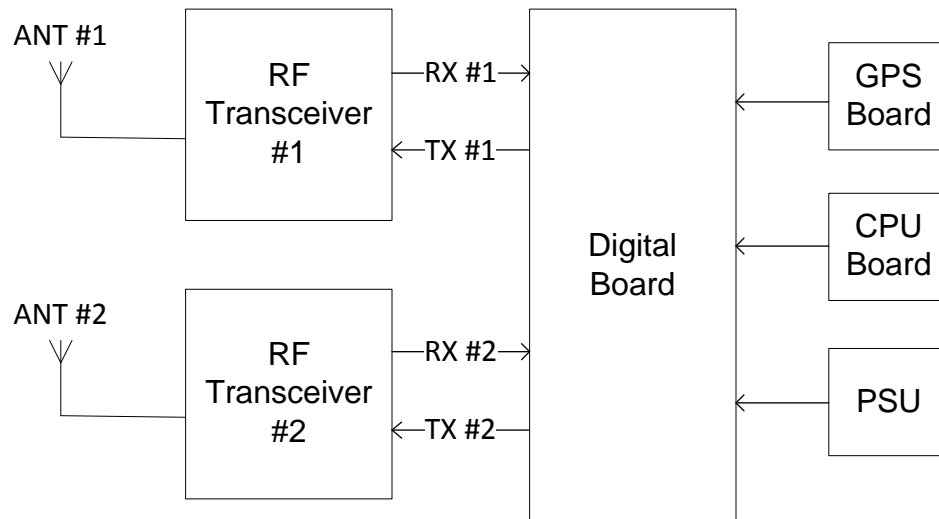

Compact Base Station Block Diagram

General block diagram



Digital board +CPU+ PSU block diagram

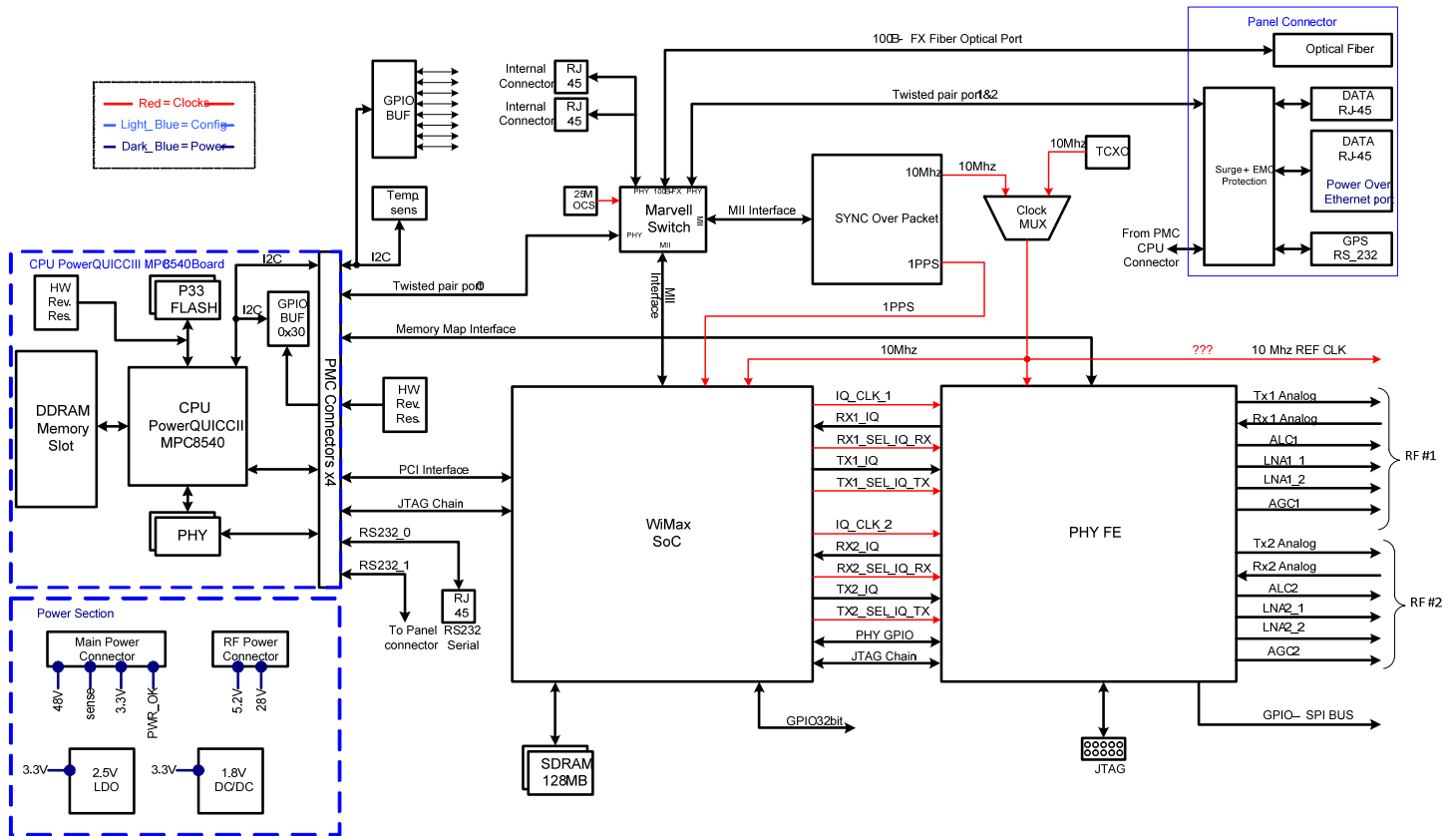

RF Transceiver block diagram

There are 2 transceivers in the Compact base station (to get full MIMO 2xTX + 2xRX), each one connected to antenna. This is the block diagram of single transceiver

