

TEST REPORT

ACCORDING TO: FCC CFR 47 Part 90 subpart Y

FOR:

Ruggedcom Ltd.

**Subscriber unit operating
in 4.9 GHz band**

Models: WiN5249

WiN5149-AC

WiN5149-DC

FCC ID:VG5WIN5X49

This report is in conformity with ISO/IEC 17025. The "A2LA Accredited" symbol endorsement applies only to the tests and calibrations that are listed in the scope of Hermon Laboratories accreditation. The test results relate only to the items tested. This test report shall not be reproduced in any form except in full with the written approval of Hermon Laboratories Ltd.

Table of contents

1	Applicant information	3
2	Equipment under test attributes	3
3	Manufacturer information	3
4	Test details	3
5	Tests summary	4
6	EUT description	5
6.1	General information	5
6.2	Ports and lines	5
6.3	Auxiliary equipment	5
6.4	Changes made in EUT	5
6.5	Test configuration	6
6.6	Transmitter characteristics	7
7	Transmitter tests according to 47CFR part 90 requirements	8
7.1	Maximum conducted output power	8
7.2	Peak power spectral density	10
7.3	Occupied bandwidth test	18
7.4	Emission mask test	26
7.5	Spurious emissions at RF antenna connector test	34
7.6	Radiated spurious emission measurements	45
7.7	Frequency stability test	57
8	APPENDIX A Test equipment and ancillaries used for tests	59
9	APPENDIX B Measurement uncertainties	60
10	APPENDIX C Test laboratory description	61
11	APPENDIX D Specification references	61
12	APPENDIX E Test equipment correction factors	62
13	APPENDIX F Abbreviations and acronyms	70

1 Applicant information

Client name: Ruggedcom Ltd.
Address: 32 Maskit Street, P.O.Box 12412, Herzeliya 46733, Israel
Telephone: +972 9951 9556
Fax: +972 9951 9557
E-mail: AmnonAssulin@ruggedcom.com
Contact name: Mr. Amnon Assulin

2 Equipment under test attributes

Product name: Subscriber unit operating in 4.9 GHz band
Product type: Transceiver
Model(s): WiN5149
Serial number: 24912912001
Hardware version: RFID=21
Software release: SS4.3.4624.21
Receipt date: 8/21/2012

3 Manufacturer information

Manufacturer name: Ruggedcom Ltd.
Address: 32 Maskit Street, P.O.Box 12412, Herzeliya 46733, Israel
Telephone: +972 9951 9556
Fax: +972 9951 9557
E-Mail: AmnonAssulin@ruggedcom.com
Contact name: Mr. Amnon Assulin



4 Test details

Project ID: 23639
Location: Hermon Laboratories Ltd. Harakevet Industrial Zone, Binyamina 30500, Israel
Test started: 8/21/2012
Test completed: 9/02/2012
Test specification(s): 47CFR Part 90 subpart Y

5 Tests summary

Test	Status
Transmitter characteristics	
Section 90.205, 90.1215, Maximum conducted output power	Pass
Section 90.1215, Peak power spectral density	Pass
Section 90.209, Occupied bandwidth	Pass
Section 90.210(l), 90.210(m), Emission mask	Pass
Section 90.210(l), 90.210(m), Spurious emissions at RF antenna connector	Pass
Section 90.210(l), 90.210(m), Radiated spurious emissions	Pass
Section 90.213, Frequency stability	Pass
Section 90.1217, RF exposure	Pass

Testing was completed against all relevant requirements of the test standard. The results obtained indicate that the product under test complies in full with the requirements tested.
The test results relate only to the items tested. Pass/ fail decision was based on nominal values.

	Name and Title	Date	Signature
Tested by:	Mrs. E. Pitt, test engineer	September 2, 2012	
Reviewed by:	Mrs. M. Cherniavsky, certification engineer	September 6, 2012	
Approved by:	Mr. M. Nikishin, EMC and radio group manager	October 3, 2012	

6 EUT description

6.1 General information

The EUT, WIN5149/WIN5249, is a subscriber unit of WiMAX system, installed at the customer premises. It comprises an Outdoor Unit (ODU) that includes modem, radio, data processing and management components, serving as an efficient platform for a wide range of services. It provides a wireless connection to the base station. Data is fed to the EUT through the RJ-45 port. The EUT is sending the data via wireless connection to the base station.

The difference between WIN5149 and WIN5249 is the antenna connectors. The **WIN5249** has internal (on-mechanic) antenna, and it is powered by WIN1010 power adapter unit (48VDC). WIN5149 has external N-Type connectors for antennas. The WIN5149 has 2 sub-models, WIN5149-AC and WIN5149-DC. The **WIN5149-AC** is powered by WIN1010 power adapter unit (48VDC), and the **WIN5149-DC** is powered by car's 12V battery. The "Mobile subscriber unit" is installed in car (vehicular environment); "Fixed subscriber unit" is installed on roofs, towers, etc.

The EUT model Win5149-AC powered by power adapter unit was tested.

6.2 Ports and lines

Port type	Port description	Connected from	Connected to	Qty.	Cable type	Cable length, m
Power	AC power	PoE adapter	AC mains	1	Unshielded	3
Power and telecom	48 VDC + Ethernet	EUT	PoE adapter	1	Shielded	3
RF	Antenna	EUT	Coupler	1	Coax	1

6.3 Support and test equipment

Description	Manufacturer	Model number	Serial number
Laptop	Lenovo	T410	2522WZN
PoE adapter (CPE)	RuggedWireless Ltd.	Win1010 (0334B4848)	0507047
Directional coupler	Narda	4203-10	06978

6.4 Changes made in EUT

No changes were implemented in the EUT.

6.5 Test configuration

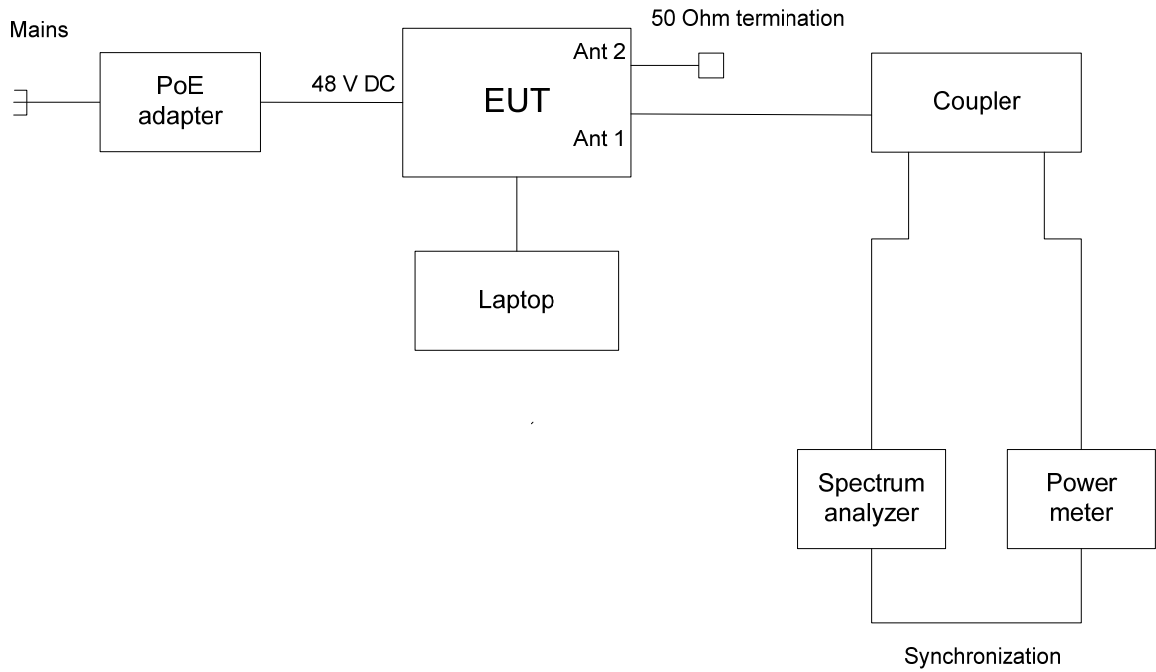



6.6 Transmitter characteristics

Type of equipment					
<input checked="" type="checkbox"/>	Stand-alone (Equipment with or without its own control provisions)				
	Combined equipment (Equipment where the radio part is fully integrated within another type of equipment)				
	Plug-in card (Equipment intended for a variety of host systems)				
Intended use		Condition of use			
<input checked="" type="checkbox"/>	fixed	Always at a distance more than 2 m from all people			
<input checked="" type="checkbox"/>	mobile	Always at a distance more than 20 cm from all people			
	portable	May operate at a distance closer than 20 cm to human body			
Assigned frequency range		4940.0 – 4990.0 MHz			
Operating frequency range		4942.5 – 4987.5 MHz			
RF channel bandwidth		5 MHz, 10 MHz			
Maximum rated output power		At transmitter 50 Ω RF output connector		24.76 dBm for 5 MHz CBW 24.20 dBm for 10 MHz CBW	
Is transmitter output power variable?		No			
		<input checked="" type="checkbox"/>	Yes	continuous variable	
				stepped variable with stepsize	0.5 dB
				minimum RF power	-21 dBm
maximum RF power	24.76 dBm				
Antenna connection					
unique coupling	<input checked="" type="checkbox"/>	standard connector	Integral	<input checked="" type="checkbox"/> with temporary RF connector without temporary RF connector	
Antenna/s technical characteristics					
Type	Manufacturer	Model number	Gain		
Dual slant antenna	MTI Wireless Edge Ltd.	MT-465017/SVH/E (ANTN0072)	22.5 dBi		
Dual slant antenna	MTI Wireless Edge Ltd.	MT-465017/NVH (ANTN0073, NTYPE)	22.5 dBi		
Omnidirectional	MTI Wireless Edge Ltd.	MT 462008/N/A (ANTN0076, N-Female)	9.5 dBi		
Omnidirectional	HUBER-SUHNER	SWA-0860/360/4/0/V_2, 1399.17.0099 (ANTN0075, N Female)	9.5 dBi		
Transmitter 99% power bandwidth		5 MHz, 10 MHz			
Type of modulation		QPSK 1/2, 16QAM 3/4, 64QAM 5/6			
Transmitter aggregate data rate/s, Mbps					
Bandwidth, MHz	Direction	QPSK 1/2	16QAM 3/4	64QAM 5/6	
5	DL	4.608	13.824	23.04	
	UL	1.4688	4.4064	7.344	
10	DL	9.216	27.648	46.08	
	UL	3.024	9.072	15.12	
Type of multiplexing		OFDMA			
Modulating test signal (baseband)		PRBS			
Maximum transmitter duty cycle in normal use		33%	Tx ON time	Period	
Transmitter duty cycle supplied for test		30%	Tx ON time	Period	
Transmitter power source					
		Nominal rated voltage	Battery type		
<input checked="" type="checkbox"/>	DC	Nominal rated voltage	48 V (via DC power supply from the mains)		
	AC mains	Nominal rated voltage	Frequency		
Transmitter power source 2					
		Nominal rated voltage	Battery type		
<input checked="" type="checkbox"/>	DC	Nominal rated voltage	12 VDC from power supply		
	AC mains	Nominal rated voltage	Frequency		
Common power source for transmitter and receiver		<input checked="" type="checkbox"/>	yes	no	



Test specification:		Section 90.1215, Maximum conducted output power	
Test procedure:		47 CFR, Section 2.1046; TIA/EIA-603-C, Section 2.2.1	
Test mode:		Compliance	
Date(s):		8/21/2012 - 8/22/2012	
Temperature: 24 °C		Air Pressure: 1006 hPa	
		Relative Humidity: 40 %	
		Power Supply: 48 VDC	
Remarks:			

7 Transmitter tests according to 47CFR part 90 requirements

7.1 Maximum conducted output power

7.1.1 General

This test was performed to measure the maximum output power at the transmitter RF antenna connector. Specification test limits are given in Table 7.1.1.

Table 7.1.1 Maximum conducted output power limits

Assigned frequency range, MHz	Channel bandwidth, MHz	Maximum peak output power	
		mW	dBm
High power device			
4940.0 – 4990.0	5	500	27.0
	10	1000	30.0

*- If transmitting antennas of directional gain greater than 9 dBi are used, the maximum conducted output power limit should be reduced below the stated value as follows:

- by the amount in dB that the directional gain of antenna exceeds 9 dBi;
- without any corresponding reduction for fixed point-to-point and point-to-multipoint transmitters employing antennas with directional gain up to 26 dBi;
- corresponding reduction in the peak output power and peak power spectral density limit should be the amount in dB that the directional gain of antenna exceeds 26 dBi.

7.1.2 Test procedure

7.1.2.1 The EUT was set up as shown in Figure 7.1.1, energized and its proper operation was checked.

7.1.2.2 The EUT was adjusted to produce maximum available for end user RF output power.

7.1.2.3 The peak output power was measured with a power meter as provided in Table 7.1.2.

Figure 7.1.1 Transmitter output power test setup

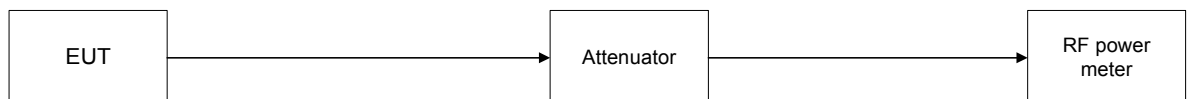



Test specification:		Section 90.1215, Maximum conducted output power	
Test procedure:		47 CFR, Section 2.1046; TIA/EIA-603-C, Section 2.2.1	
Test mode:		Compliance	
Date(s):		8/21/2012 - 8/22/2012	
Temperature: 24 °C		Air Pressure: 1006 hPa	
		Relative Humidity: 40 %	
		Power Supply: 48 VDC	
Remarks:			
Verdict: PASS			

Table 7.1.2 Peak output power test results

ASSIGNED FREQUENCY RANGE: 4940.0 – 4990.0 MHz
 DETECTOR USED: Average (Power meter)
 RESOLUTION BANDWIDTH: NA
 VIDEO BANDWIDTH: NA
 MODULATING SIGNAL: PRBS
 TRANSMITTER OUTPUT POWER SETTINGS: Maximum

CHANNEL BANDWIDTH: 5 MHz

Carrier frequency, MHz	Power meter reading, dBm	External attenuation & cable loss, dB	RF output power, dBm	Limit*, dBm	Margin**, dB	Verdict
QPSK						
4942.5	24.76	Included	24.76	26.5	-1.74	Pass
4962.5	24.52	Included	24.52	26.5	-1.98	Pass
4987.5	24.29	Included	24.29	26.5	-2.21	Pass
64 QAM						
4942.5	24.70	Included	24.70	26.5	-1.80	Pass
4962.5	24.52	Included	24.52	26.5	-1.98	Pass
4987.5	24.30	Included	24.30	26.5	-2.20	Pass

CHANNEL BANDWIDTH: 10 MHz

Carrier frequency, MHz	Power meter reading, dBm	External attenuation & cable loss, dB	RF output power, dBm	Limit*, dBm	Margin**, dB	Verdict
QPSK						
4947.5	24.00	Included	24.00	29.5	-5.50	Pass
4962.5	24.20	Included	24.20	29.5	-5.30	Pass
4982.5	24.00	Included	24.00	29.5	-5.50	Pass
64 QAM						
4947.5	24.10	Included	24.10	29.5	-5.40	Pass
4962.5	24.20	Included	24.20	29.5	-5.30	Pass
4982.5	24.10	Included	24.10	29.5	-5.40	Pass

*The limit was reduced 0.5 dB for 9.5 dBi antenna gain. If the device is used in fixed installation only, no reduction in the power limit is allowed for 22.5 dBi antenna use.

** - Margin, dB = RF output power, dBm – calculated limit, dBm.

Reference numbers of test equipment used

HL 3301	HL 3302	HL 3786	HL 4366			
---------	---------	---------	---------	--	--	--

Full description is given in Appendix A.

Test specification:	Section 90.1215, Peak power spectral density		
Test procedure:	47 CFR, Section 2.1051; TIA/EIA-603-C, Section 2.2.1		
Test mode:	Compliance	Verdict:	PASS
Date(s):	8/21/2012 - 8/22/2012		
Temperature: 24 °C	Air Pressure: 1006 hPa	Relative Humidity: 40 %	Power Supply: 48 VDC
Remarks:			

7.2 Peak power spectral density

7.2.1 General

This test was performed to measure the peak power spectral density at the transmitter RF antenna connector. Specification test limits are given in Table 7.2.1.

Table 7.2.1 Peak power spectral density limits

Assigned frequency range, MHz	Channel bandwidth, MHz	Peak power spectral density, dBm/MHz
High power device		
4940.0 – 4990.0	5	21
	10	

*- If transmitting antennas of directional gain greater than 9 dBi are used, the peak power spectral density limit should be reduced below the stated value as follows:
 by the amount in dB that the directional gain of antenna exceeds 9 dBi;
 without any corresponding reduction for fixed point-to-point and point-to-multipoint transmitters employing antennas with directional gain up to 26 dBi;
 corresponding reduction in the peak output power and peak power spectral density limit should be the amount in dB that the directional gain of antenna exceeds 26 dBi.

7.2.2 Test procedure

7.2.2.1 The EUT was set up as shown in Figure 7.2.1, energized and its proper operation was checked.

7.2.2.2 The EUT was adjusted to produce maximum available for end user RF output power.

7.2.2.3 The peak output power was measured with a spectrum analyzer as provided in Table 7.2.2 and the associated plots.

Figure 7.2.1 Power spectral density test setup

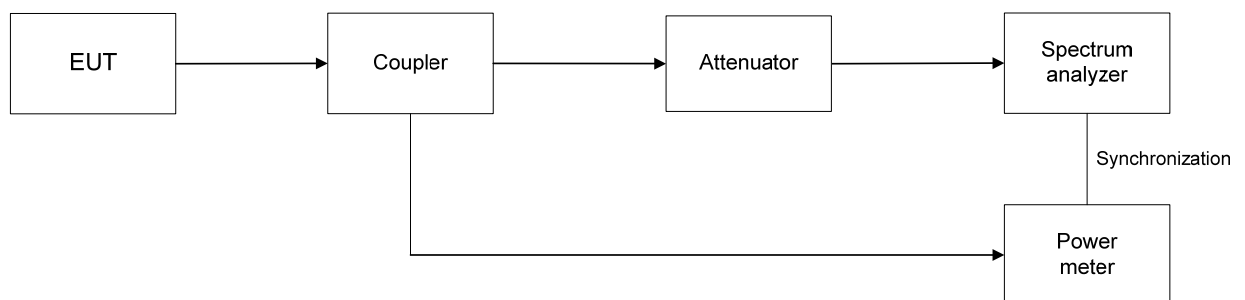

Test specification:	Section 90.1215, Peak power spectral density		
Test procedure:	47 CFR, Section 2.1051; TIA/EIA-603-C, Section 2.2.1		
Test mode:	Compliance	Verdict:	PASS
Date(s):	8/21/2012 - 8/22/2012		
Temperature: 24 °C	Air Pressure: 1006 hPa	Relative Humidity: 40 %	Power Supply: 48 VDC
Remarks:			

Table 7.2.2 Peak power spectral density test results

ASSIGNED FREQUENCY RANGE: 4940.0 – 4990.0 MHz
DETECTOR USED: Average
RESOLUTION BANDWIDTH: 1 MHz
VIDEO BANDWIDTH: 3 MHz
MODULATING SIGNAL: PRBS
TRANSMITTER OUTPUT POWER SETTINGS: Maximum

CHANNEL BANDWIDTH: 5 MHz

Carrier frequency, MHz	Spectrum analyzer reading dBm/MHz	External attenuation & cable loss, dB	Power spectral density, dBm/MHz	Limit*, dBm/MHz	Margin**, dB	Verdict
QPSK						
4942.5	17.91	Included	17.91	20.5	-2.59	Pass
4962.5	18.12	Included	18.12		-2.38	Pass
4987.5	17.54	Included	17.54		-2.96	Pass
64 QAM						
4942.5	18.03	Included	18.03	20.5	-2.47	Pass
4962.5	18.31	Included	18.31		-2.19	Pass
4987.5	17.04	Included	17.04		-3.46	Pass

CHANNEL BANDWIDTH: 10MHz

Carrier frequency, MHz	Spectrum analyzer reading dBm/MHz	External attenuation & cable loss, dB	Power spectral density, dBm/MHz	Limit*, dBm/MHz	Margin**, dB	Verdict
QPSK						
4947.5	13.46	Included	13.46	20.5	-7.04	Pass
4962.5	14.85	Included	14.85		-5.65	Pass
4982.5	14.50	Included	14.50		-6.00	Pass
64 QAM						
4947.5	14.38	Included	14.38	20.5	-6.12	Pass
4962.5	14.81	Included	14.81		-5.69	Pass
4982.5	14.59	Included	14.59		-5.9s1	Pass

*The limit was reduced 0.5 dB for 9.5 dBi antenna gain. If the device is used in fixed installation only, no reduction in the power spectral density limit is allowed for 22.5 dBi antenna use.

** - Margin, dB = Power density, dBm/MHz – calculated limit, dBm/MHz.

Reference numbers of test equipment used

HL 3301	HL 3302	HL 3442	HL 3786	HL 3818	HL 3903	HL 4366	
---------	---------	---------	---------	---------	---------	---------	--

Full description is given in Appendix A.

Test specification:		Section 90.1215, Peak power spectral density	
Test procedure:		47 CFR, Section 2.1051; TIA/EIA-603-C, Section 2.2.1	
Test mode:		Compliance	Verdict: PASS
Date(s):		8/21/2012 - 8/22/2012	
Temperature: 24 °C	Air Pressure: 1006 hPa	Relative Humidity: 40 %	Power Supply: 48 VDC
Remarks:			

Plot 7.2.1 Peak output power spectral density test results at low frequency

CHANNEL BANDWIDTH:
MODULATION:

5 MHz
QPSK

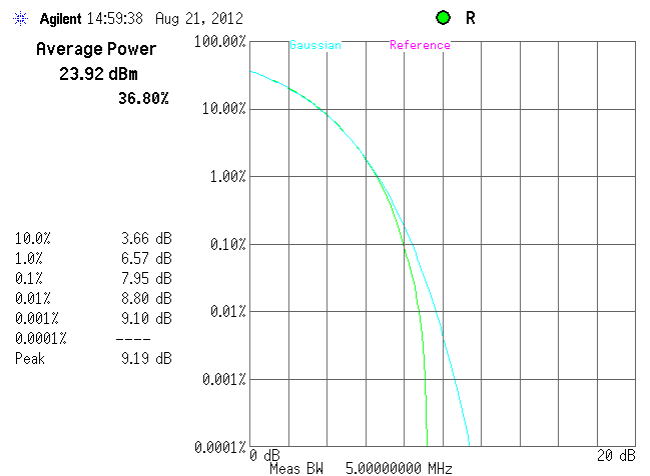
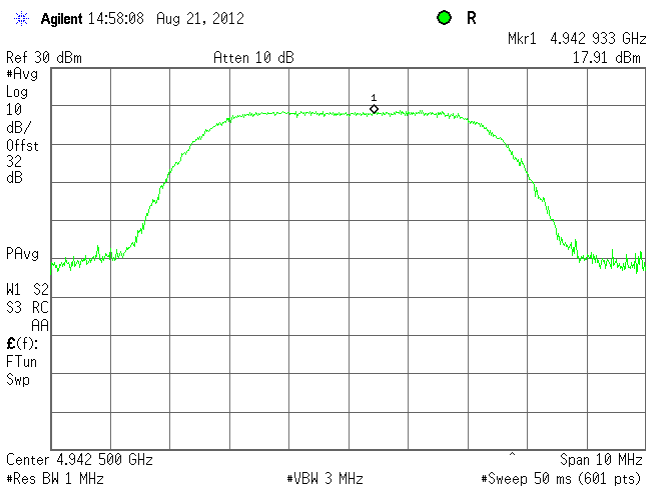

Plot 7.2.2 Peak output power spectral density test results at low frequency

CHANNEL BANDWIDTH:
MODULATION:

5 MHz
64 QAM

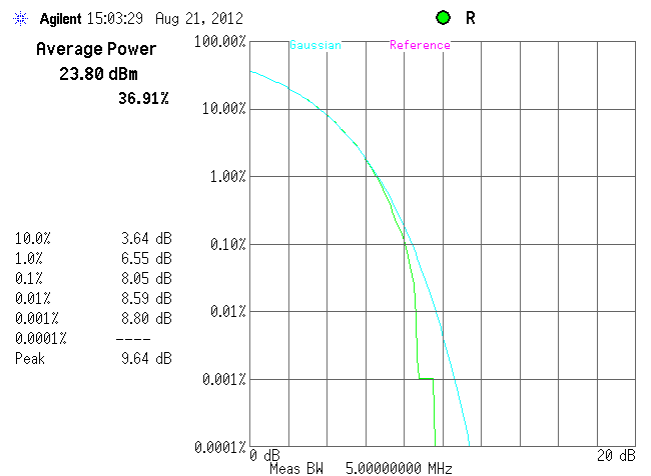
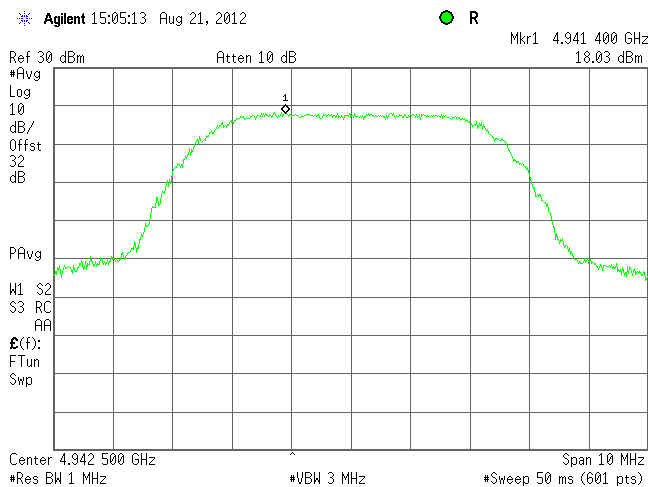

Test specification:		Section 90.1215, Peak power spectral density	
Test procedure:		47 CFR, Section 2.1051; TIA/EIA-603-C, Section 2.2.1	
Test mode:		Compliance	Verdict: PASS
Date(s):		8/21/2012 - 8/22/2012	
Temperature: 24 °C	Air Pressure: 1006 hPa	Relative Humidity: 40 %	Power Supply: 48 VDC
Remarks:			

Plot 7.2.3 Peak output power spectral density test results at mid frequency

CHANNEL BANDWIDTH:
MODULATION:

5 MHz
QPSK

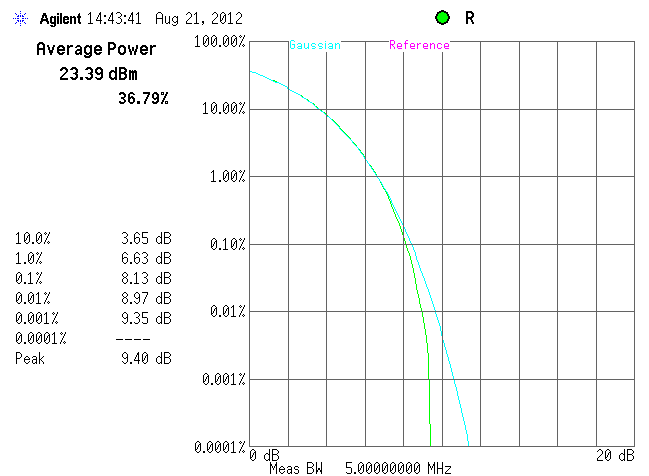
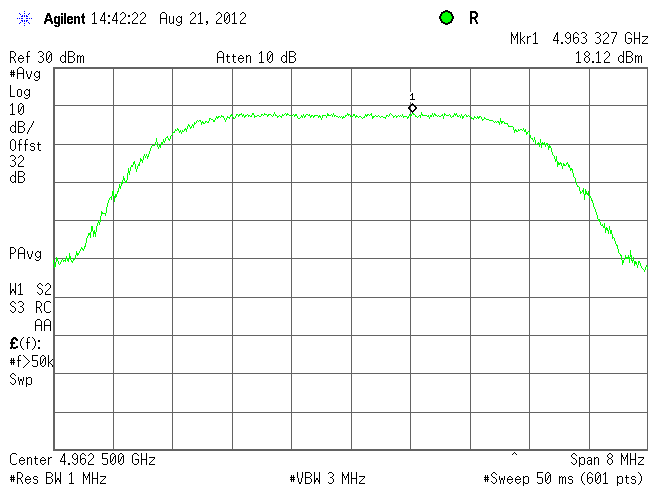

Plot 7.2.4 Peak output power spectral density test results at mid frequency

CHANNEL BANDWIDTH:
MODULATION:

5 MHz
64 QAM

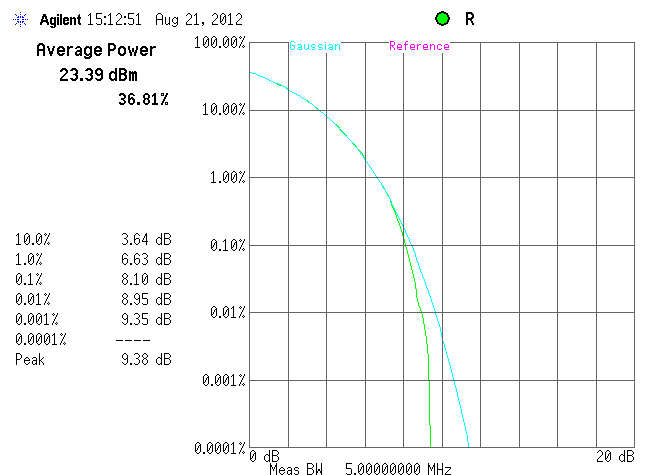
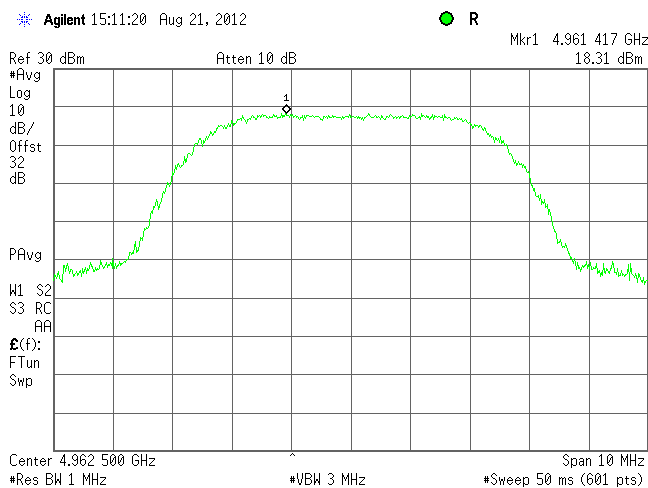

Test specification:		Section 90.1215, Peak power spectral density	
Test procedure:		47 CFR, Section 2.1051; TIA/EIA-603-C, Section 2.2.1	
Test mode:		Compliance	Verdict: PASS
Date(s):		8/21/2012 - 8/22/2012	
Temperature: 24 °C	Air Pressure: 1006 hPa	Relative Humidity: 40 %	Power Supply: 48 VDC
Remarks:			

Plot 7.2.5 Peak output power spectral density test results at high frequency

CHANNEL BANDWIDTH:
MODULATION:

5 MHz
QPSK

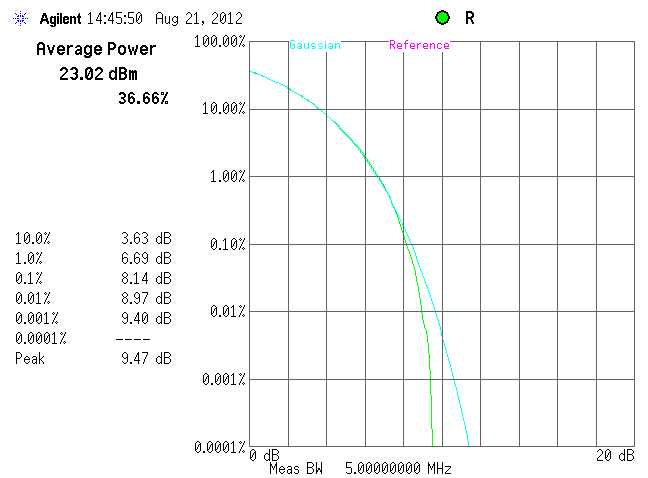
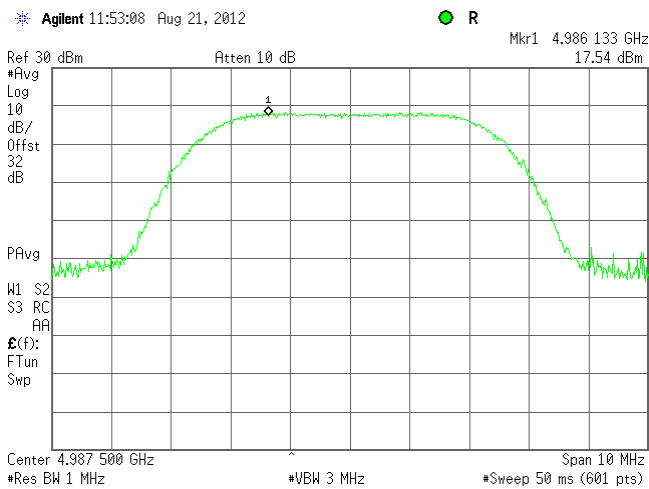

Plot 7.2.6 Peak output power spectral density test results at high frequency

CHANNEL BANDWIDTH:
MODULATION:

5 MHz
64 QAM

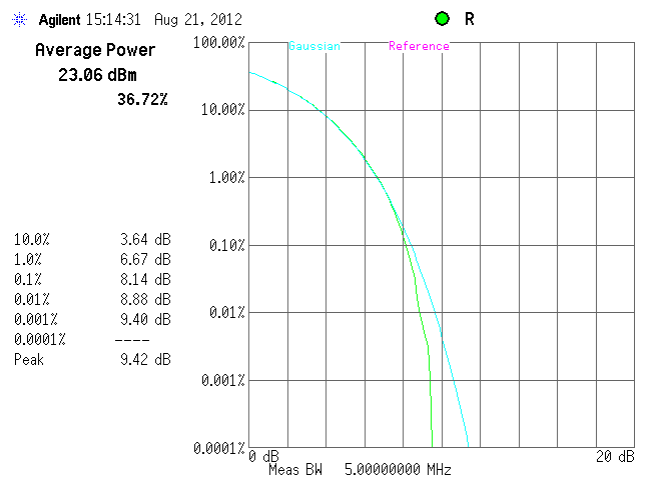
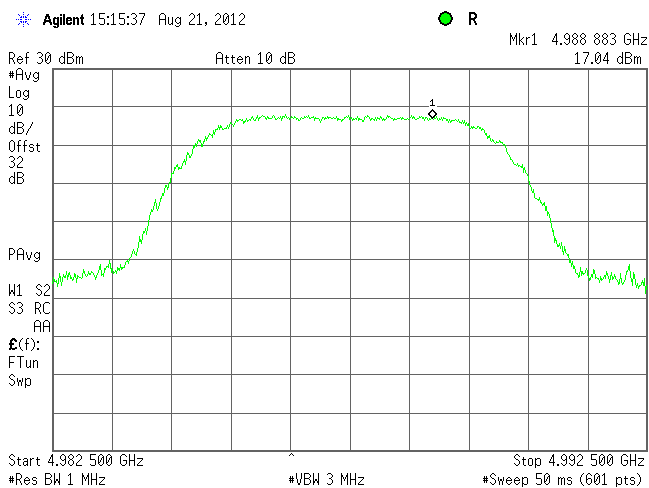

Test specification:	Section 90.1215, Peak power spectral density		
Test procedure:	47 CFR, Section 2.1051; TIA/EIA-603-C, Section 2.2.1		
Test mode:	Compliance	Verdict:	PASS
Date(s):	8/21/2012 - 8/22/2012		
Temperature: 24 °C	Air Pressure: 1006 hPa	Relative Humidity: 40 %	Power Supply: 48 VDC
Remarks:			

Plot 7.2.7 Peak output power spectral density test results at low frequency

CHANNEL BANDWIDTH:
MODULATION:

10 MHz
QPSK

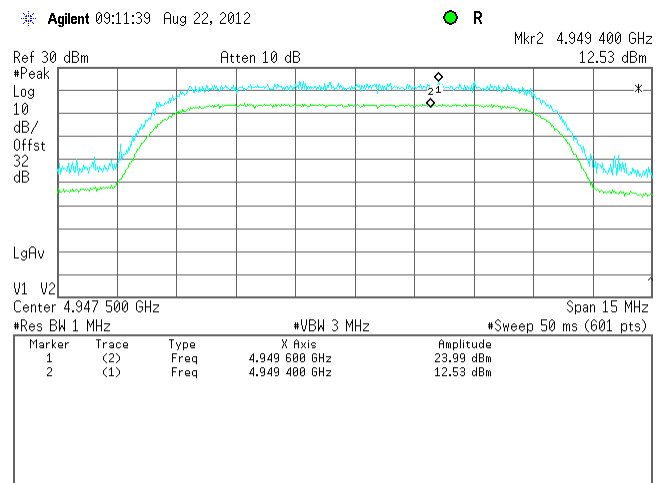
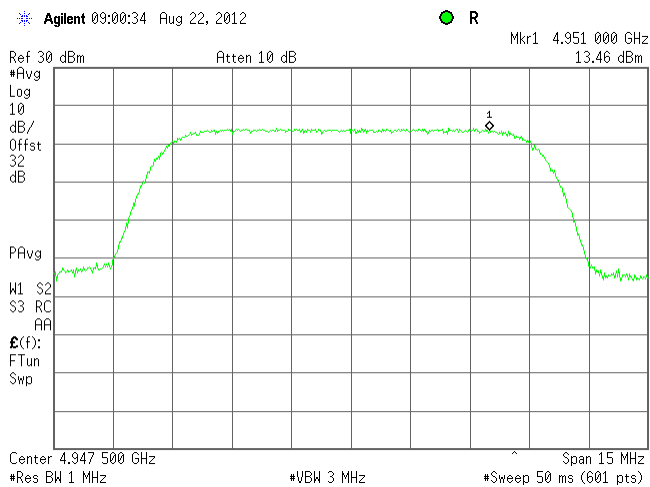

Plot 7.2.8 Peak output power spectral density test results at low frequency

CHANNEL BANDWIDTH:
MODULATION:

10 MHz
64 QAM

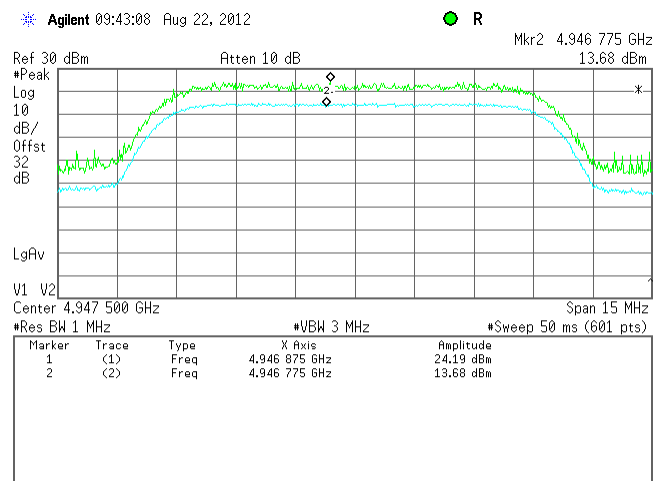
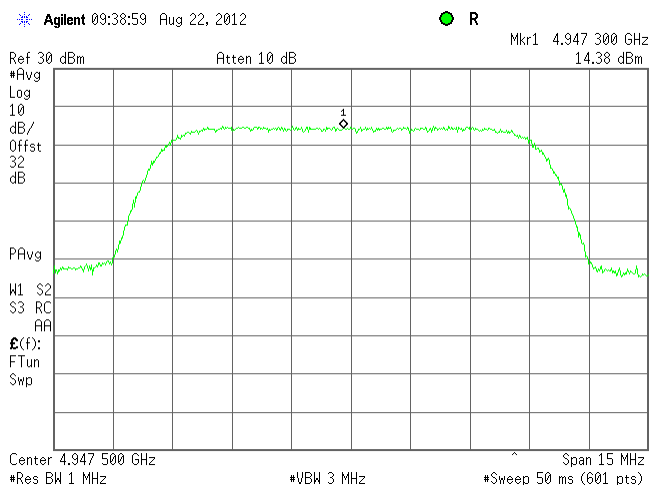

Test specification:		Section 90.1215, Peak power spectral density	
Test procedure:		47 CFR, Section 2.1051; TIA/EIA-603-C, Section 2.2.1	
Test mode:		Compliance	
Date(s):		8/21/2012 - 8/22/2012	
Temperature: 24 °C		Air Pressure: 1006 hPa	
		Relative Humidity: 40 %	
		Power Supply: 48 VDC	
Remarks:			
		Verdict: PASS	

Plot 7.2.9 Peak output power spectral density test results at mid frequency

CHANNEL BANDWIDTH:
MODULATION:

10 MHz
QPSK

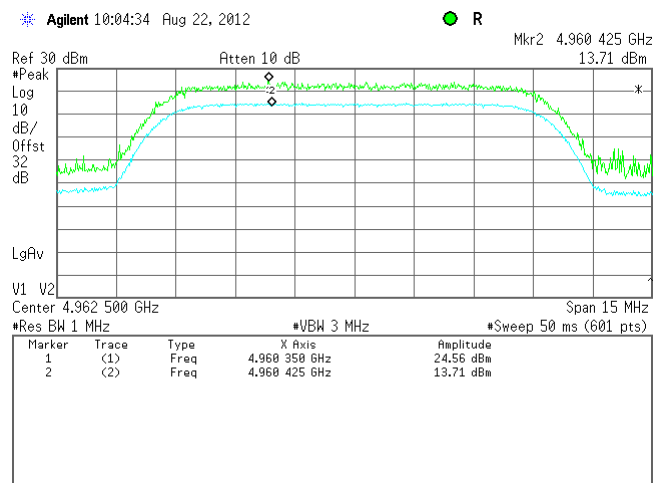
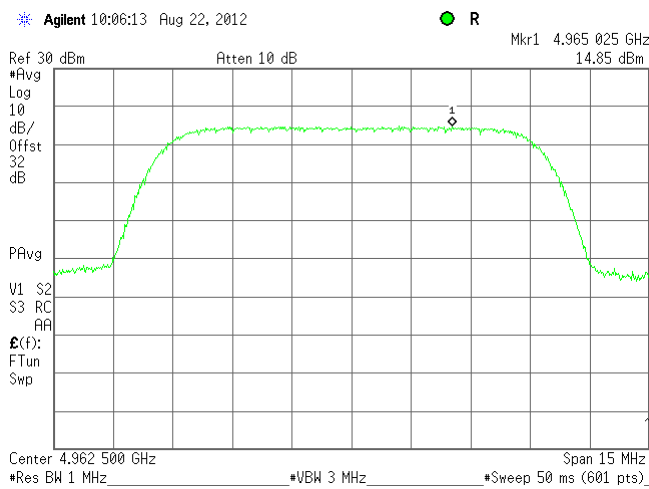

Plot 7.2.10 Peak output power spectral density test results at mid frequency

CHANNEL BANDWIDTH:
MODULATION:

10 MHz
64 QAM

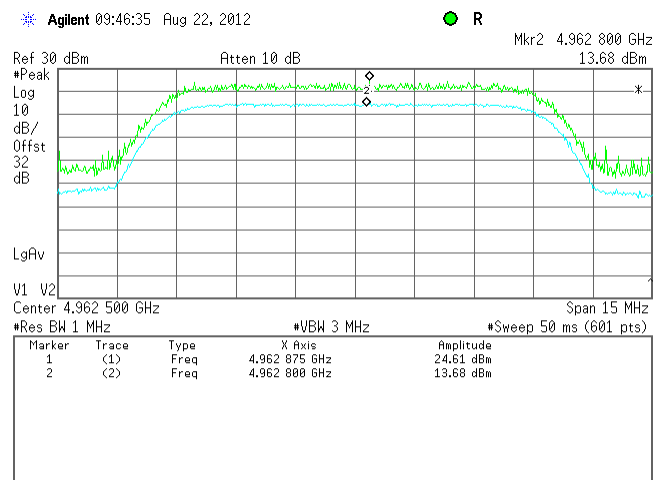
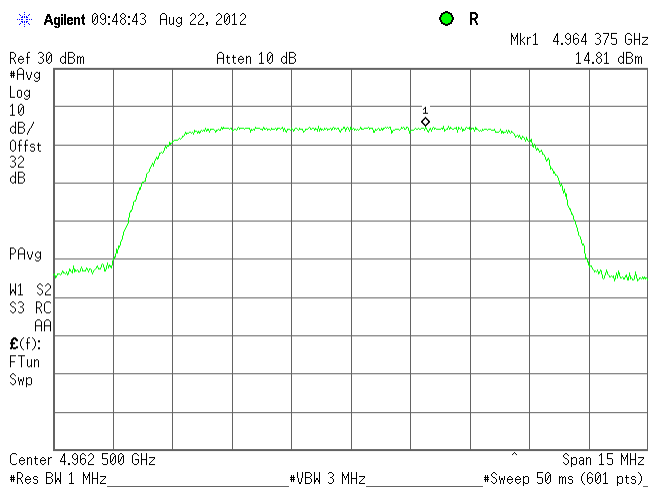

Test specification:	Section 90.1215, Peak power spectral density		
Test procedure:	47 CFR, Section 2.1051; TIA/EIA-603-C, Section 2.2.1		
Test mode:	Compliance	Verdict:	PASS
Date(s):	8/21/2012 - 8/22/2012		
Temperature: 24 °C	Air Pressure: 1006 hPa	Relative Humidity: 40 %	Power Supply: 48 VDC
Remarks:			

Plot 7.2.11 Peak output power spectral density test results at high frequency

CHANNEL BANDWIDTH:
MODULATION:

10 MHz
QPSK

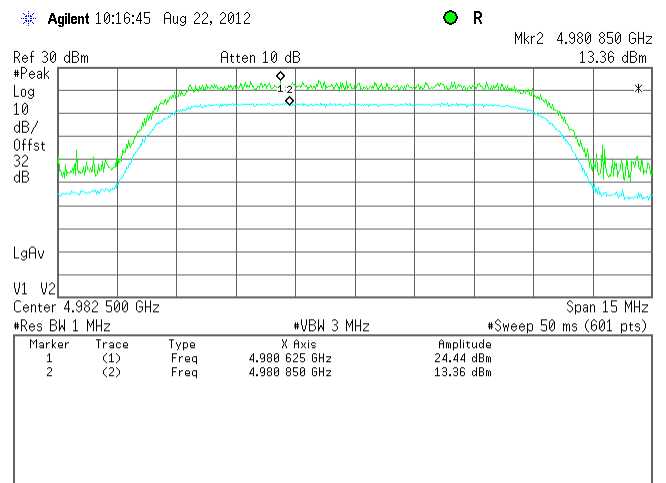
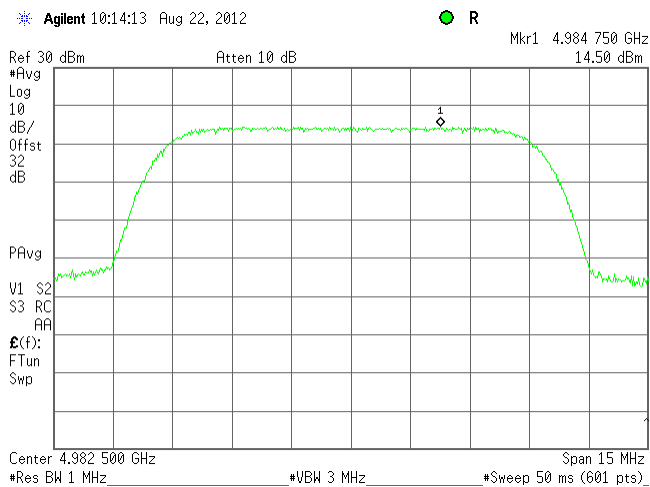

Plot 7.2.12 Peak output power spectral density test results at high frequency

CHANNEL BANDWIDTH:
MODULATION:

10 MHz
64 QAM

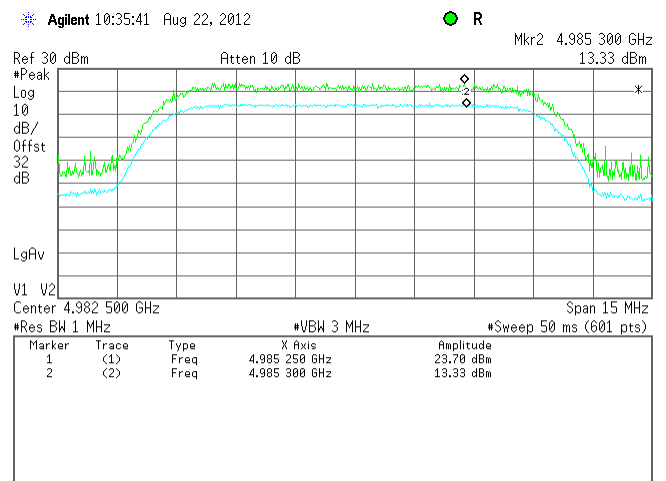
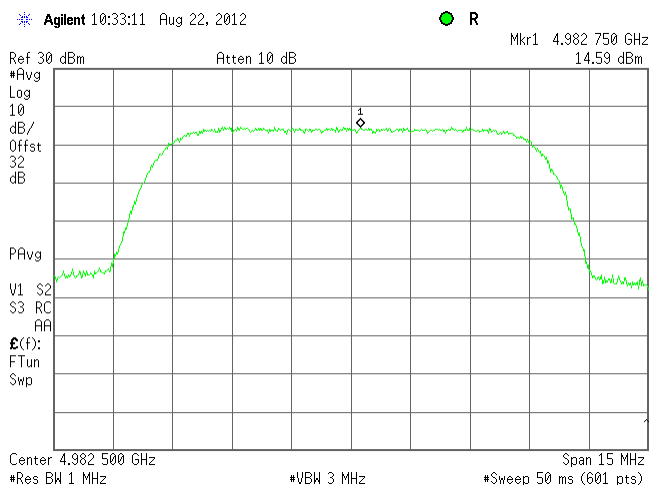



Test specification:		Section 90.209, Section 5.3, Occupied bandwidth	
Test procedure:		47 CFR, Section 2.1049	
Test mode:		Compliance	
Date(s):		8/21/2012 - 8/22/2012	
Temperature: 24 °C		Air Pressure: 1006 hPa	
		Relative Humidity: 40 %	
		Power Supply: 48 VDC	
Remarks:			

7.3 Occupied bandwidth test

7.3.1 General

This test was performed to measure transmitter occupied bandwidth. Specification test limits are given in Table 7.3.1.

Table 7.3.1 Occupied bandwidth limits

Assigned frequency, MHz	Modulation envelope reference points*, dBc	Modulation envelope reference points*, %
4940.00 – 4990.00	26	99

* - Modulation envelope reference points are provided in terms of attenuation below the average transmitted power.

7.3.2 Test procedure

7.3.2.1 The EUT was set up as shown in Figure 7.3.1, energized and its proper operation was checked.

7.3.2.2 The EUT was set to transmit the normally modulated carrier.

7.3.2.3 The transmitter occupied bandwidth was measured with spectrum analyzer as a frequency delta between the reference points on modulation envelope and provided in Table 7.3.2 and the associated plots.

Figure 7.3.1 Occupied bandwidth test setup

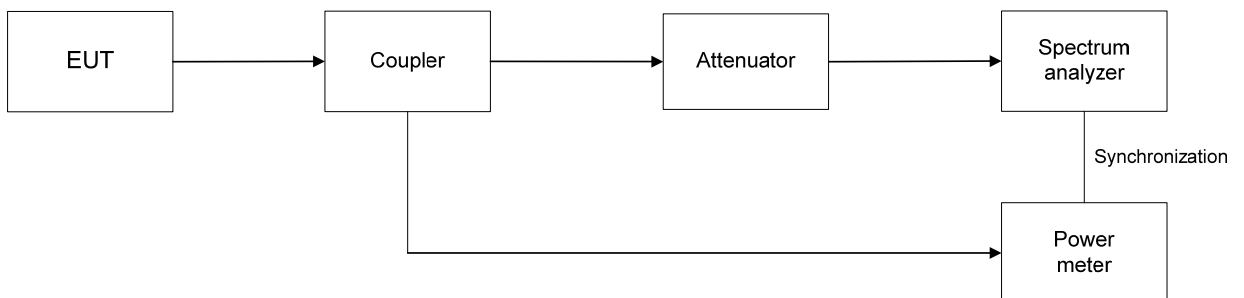



Test specification:	Section 90.209, Section 5.3, Occupied bandwidth		
Test procedure:	47 CFR, Section 2.1049		
Test mode:	Compliance	Verdict: PASS	
Date(s):	8/21/2012 - 8/22/2012		
Temperature: 24 °C	Air Pressure: 1006 hPa	Relative Humidity: 40 %	Power Supply: 48 VDC
Remarks:			

Table 7.3.2 Occupied bandwidth test results

DETECTOR USED: Average
 RESOLUTION BANDWIDTH: 100 kHz*
 VIDEO BANDWIDTH: >RBW
 MODULATING SIGNAL: PRBS

CHANNEL BANDWIDTH: 5 MHz

Modulation	Carrier frequency, MHz	Occupied bandwidth (26 dBc), MHz	Occupied bandwidth (99%), MHz	Verdict
QPSK	4942.5	4.776	4.4364	Pass
	4962.5	4.726	4.4207	
	4987.5	4.786	4.4330	
64 QAM	4942.5	4.814	4.4237	Pass
	4962.5	4.723	4.4225	
	4987.5	4.790	4.4230	

CHANNEL BANDWIDTH: 10MHz

Modulation	Carrier frequency, MHz	Occupied bandwidth (26 dBc), kHz	Occupied bandwidth (99%), kHz	Verdict
QPSK	4947.5	9.475	9.0520	Pass
	4962.5	9.609	9.0464	
	4982.5	9.609	9.0408	
64 QAM	4947.5	9.563	9.0454	Pass
	4962.5	9.431	9.0452	
	4982.5	9.450	9.0434	

* - RBW ≥ 1% of OBW; 1 % of 5 MHz is 50 kHz, 1 % of 10 MHz is 100 kHz, RBW=100 kHz was chosen for the measurements.

Reference numbers of test equipment used

HL 3301	HL 3302	HL 3442	HL 3786	HL 3818	HL 3903	HL 4366	
---------	---------	---------	---------	---------	---------	---------	--

Full description is given in Appendix A.



HERMON LABORATORIES

Test specification:		Section 90.209, Section 5.3, Occupied bandwidth	
Test procedure:		47 CFR, Section 2.1049	
Test mode:		Compliance	
Date(s):		8/21/2012 - 8/22/2012	
Temperature: 24 °C		Air Pressure: 1006 hPa	
		Relative Humidity: 40 %	
		Power Supply: 48 VDC	
Remarks:			
		Verdict: PASS	

Plot 7.3.1 Occupied bandwidth test result at low frequency, 5 MHz CBW, QPSK

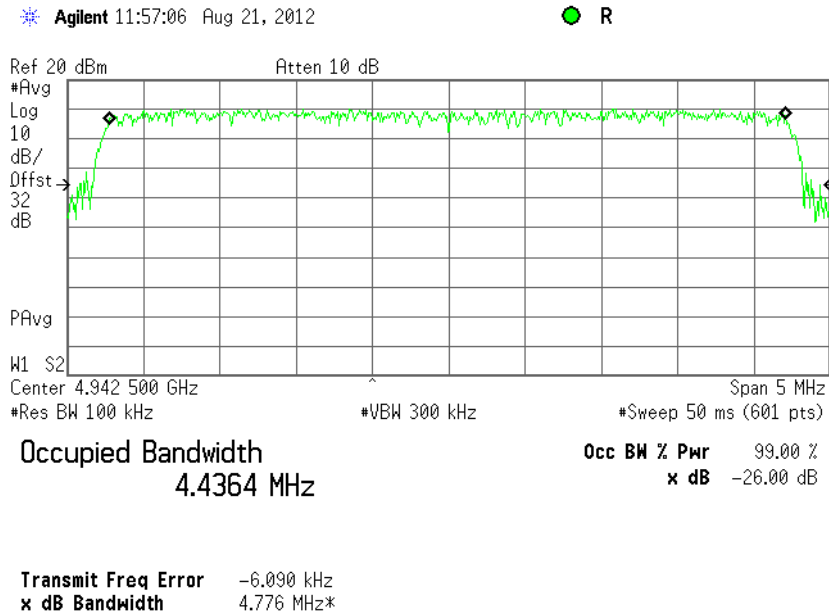

Plot 7.3.2 Occupied bandwidth test result at mid frequency, 5 MHz CBW, QPSK

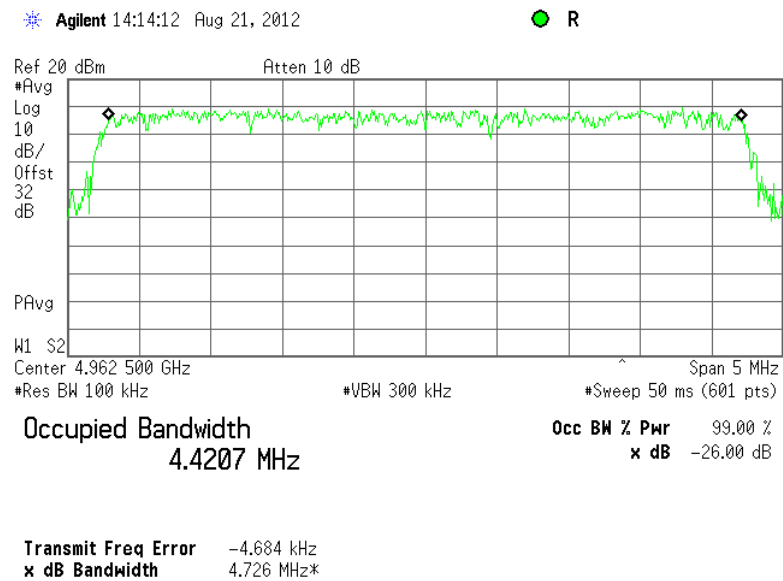



HERMON LABORATORIES

Test specification:		Section 90.209, Section 5.3, Occupied bandwidth	
Test procedure:		47 CFR, Section 2.1049	
Test mode:		Compliance	
Date(s):		8/21/2012 - 8/22/2012	
Temperature: 24 °C	Air Pressure: 1006 hPa	Relative Humidity: 40 %	Power Supply: 48 VDC
Remarks:			
		Verdict: PASS	

Plot 7.3.3 Occupied bandwidth test result at high frequency, 5 MHz CBW, QPSK

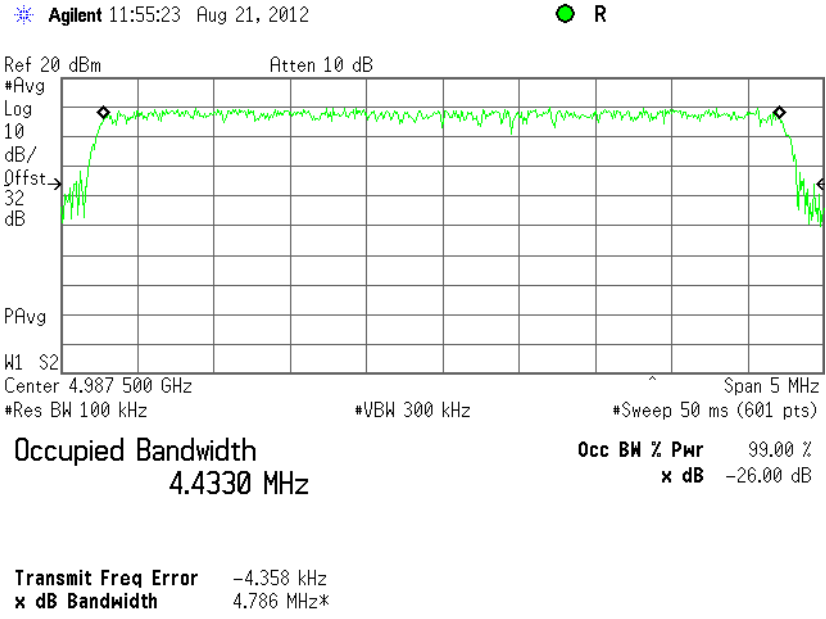

Plot 7.3.4 Occupied bandwidth test result at low frequency, 5 MHz CBW, 64 QAM

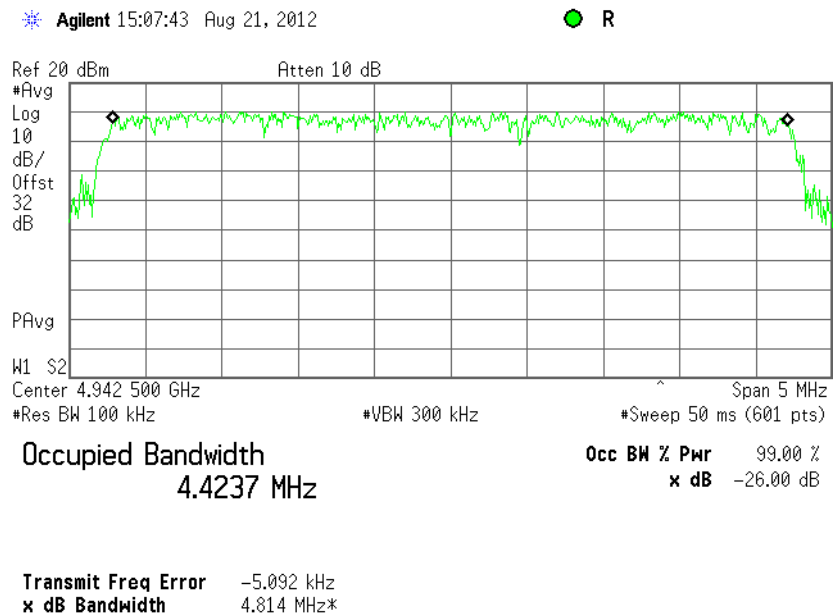



HERMON LABORATORIES

Test specification:		Section 90.209, Section 5.3, Occupied bandwidth	
Test procedure:		47 CFR, Section 2.1049	
Test mode:		Compliance	
Date(s):		8/21/2012 - 8/22/2012	
Temperature: 24 °C		Air Pressure: 1006 hPa	
		Relative Humidity: 40 %	
		Power Supply: 48 VDC	
Remarks:			
		Verdict: PASS	

Plot 7.3.5 Occupied bandwidth test result at mid frequency, 5 MHz CBW, 64 QAM

Agilent 15:09:19 Aug 21, 2012

R

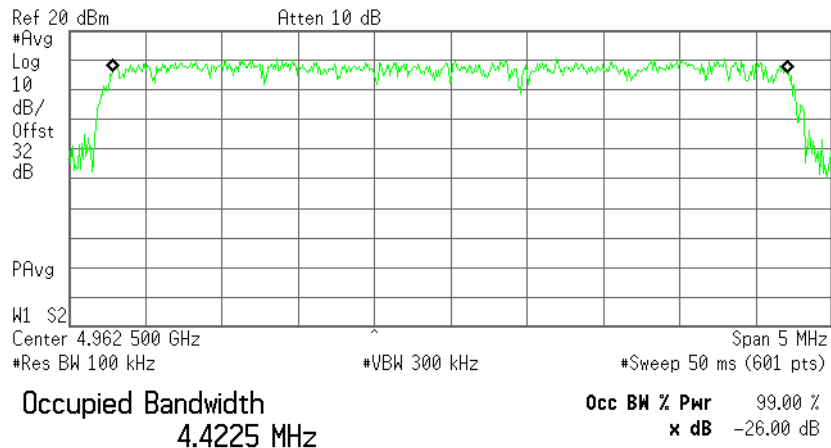

Transmit Freq Error -5.330 kHz
x dB Bandwidth 4.723 MHz*

Plot 7.3.6 Occupied bandwidth test result at high frequency, 5 MHz CBW, 64 QAM

Agilent 08:44:50 Aug 22, 2012

R

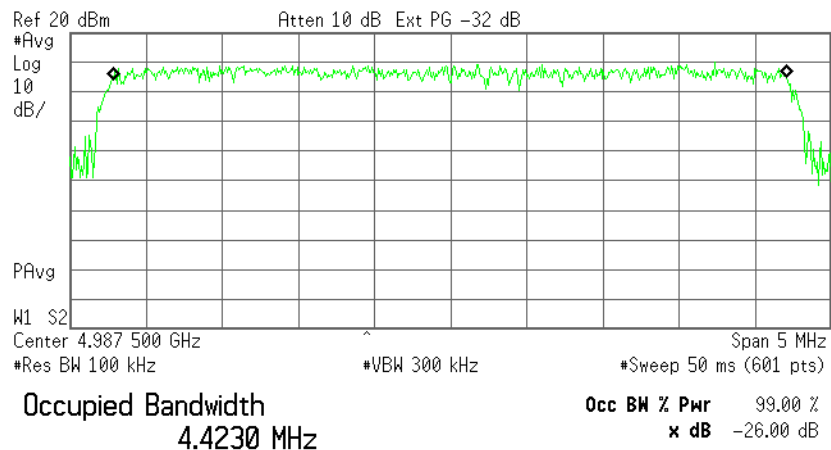

Transmit Freq Error -5.282 kHz
x dB Bandwidth 4.790 MHz*



HERMON LABORATORIES

Test specification:		Section 90.209, Section 5.3, Occupied bandwidth	
Test procedure:		47 CFR, Section 2.1049	
Test mode:		Compliance	
Date(s):		8/21/2012 - 8/22/2012	
Temperature: 24 °C		Air Pressure: 1006 hPa	
		Relative Humidity: 40 %	
		Power Supply: 48 VDC	
Remarks:			
		Verdict: PASS	

Plot 7.3.7 Occupied bandwidth test result at low frequency, 10 MHz CBW, QPSK

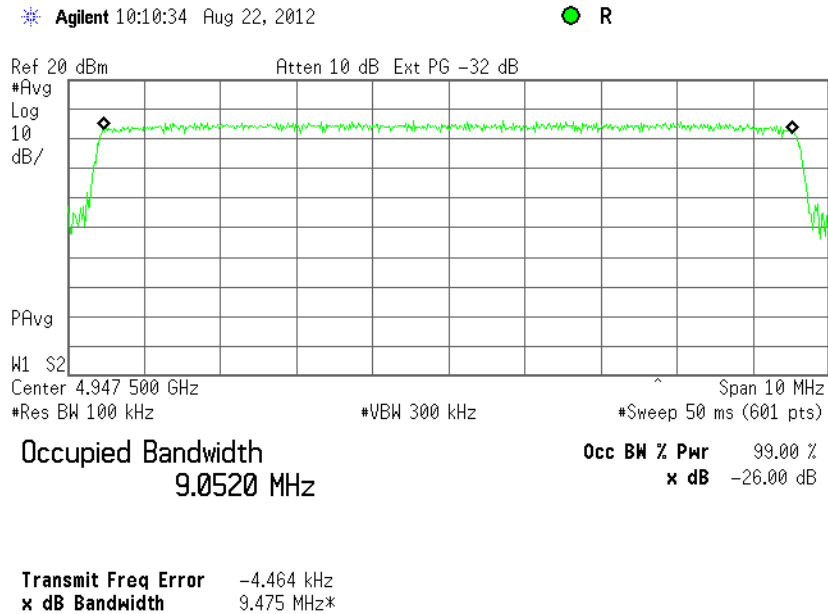

Plot 7.3.8 Occupied bandwidth test result at mid frequency, 10MHz CBW, QPSK

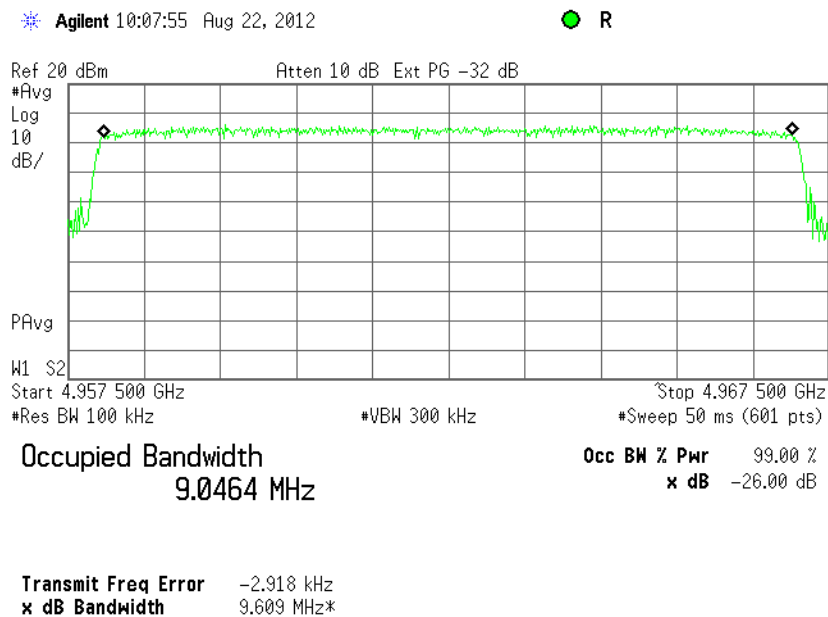



HERMON LABORATORIES

Test specification:		Section 90.209, Section 5.3, Occupied bandwidth	
Test procedure:		47 CFR, Section 2.1049	
Test mode:		Compliance	
Date(s):		8/21/2012 - 8/22/2012	
Temperature: 24 °C		Air Pressure: 1006 hPa	
		Relative Humidity: 40 %	
		Power Supply: 48 VDC	
Remarks:			
		Verdict: PASS	

Plot 7.3.9 Occupied bandwidth test result at high frequency, 10 MHz CBW, QPSK

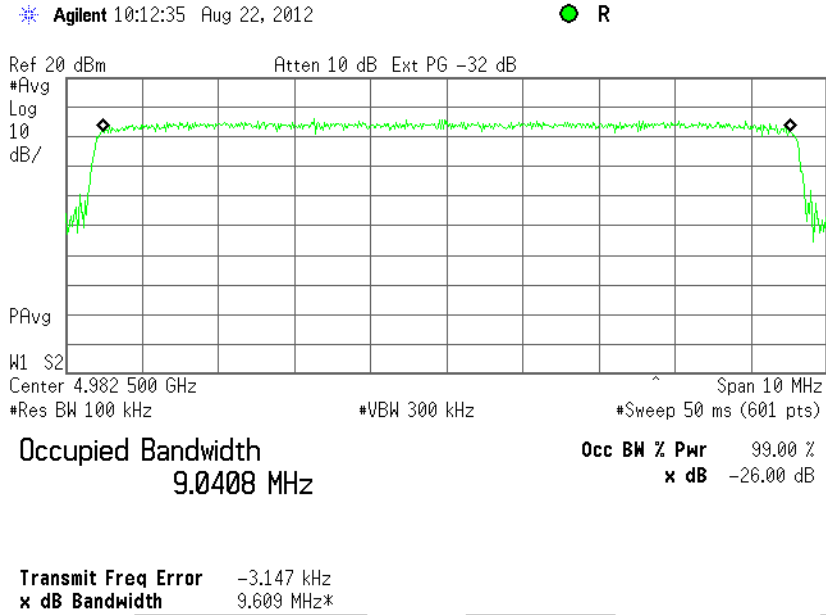

Plot 7.3.10 Occupied bandwidth test result at low frequency, 10 MHz CBW, 64 QAM

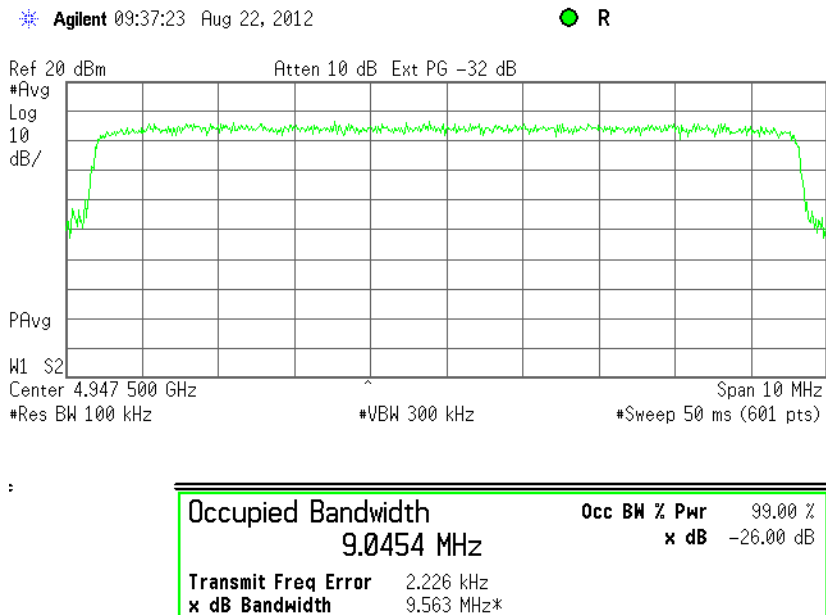



Test specification:		Section 90.209, Section 5.3, Occupied bandwidth	
Test procedure:		47 CFR, Section 2.1049	
Test mode:		Compliance	
Date(s):		8/21/2012 - 8/22/2012	
Temperature: 24 °C		Air Pressure: 1006 hPa	
Relative Humidity: 40 %		Power Supply: 48 VDC	
Remarks:			
		Verdict: PASS	

Plot 7.3.11 Occupied bandwidth test result at mid frequency, 10 MHz CBW, 64 QAM

Agilent 09:51:10 Aug 22, 2012

R

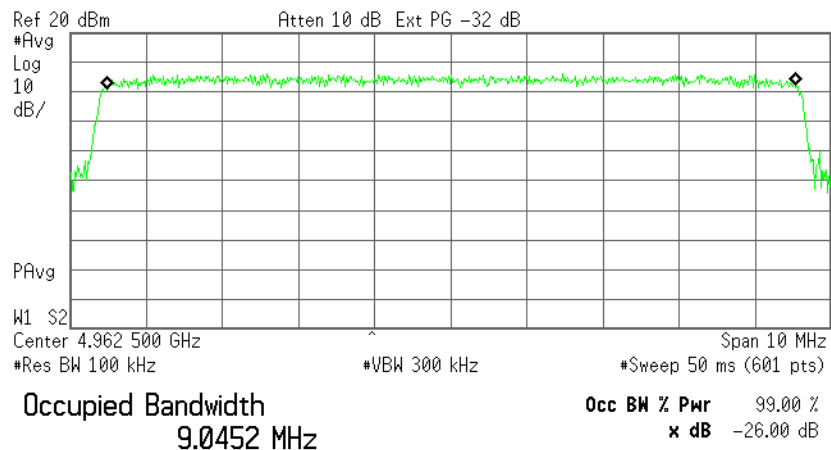

Transmit Freq Error 4.174 kHz
x dB Bandwidth 9.431 MHz*

Plot 7.3.12 Occupied bandwidth test result at high frequency, 10 MHz CBW, 64 QAM

Agilent 10:31:33 Aug 22, 2012

R

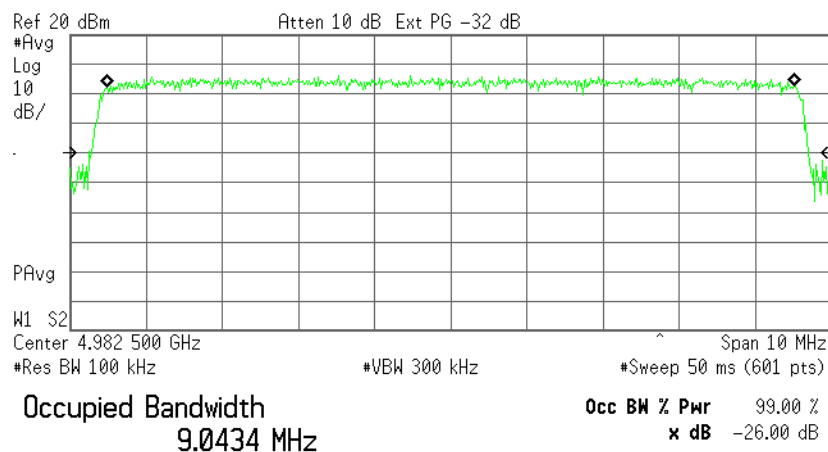

Transmit Freq Error 3.167 kHz
x dB Bandwidth 9.450 MHz*



Test specification:	Section 90.210, Emission mask		
Test procedure:	47 CFR, Sections 2.1051, 2.1047 and 90.210(l); TIA/EIA-603-C, Section 2.2.13		
Test mode:	Compliance	Verdict:	PASS
Date(s):	8/26/2012 - 8/30/2012		
Temperature: 24 °C	Air Pressure: 1006 hPa	Relative Humidity: 48 %	Power Supply: 48 VDC
Remarks:			

7.4 Emission mask test

7.4.1 General

This test was performed to measure emission mask at RF antenna connector. Specification test limits are given in Table 7.4.1.

Table 7.4.1 Emission mask limits

Frequency displacement from carrier	Attenuation below carrier, dBc
Emission mask M (Channel bandwidth 5 MHz)	
0 – 2.25 MHz	0***
2.25 – 2.5 MHz	568log(F*/2.25)
2.5 – 2.75 MHz	26+145log(F*/2.5)
2.75 – 5.0 MHz	32+31log(F*/2.75)
5.0 – 7.5 MHz	40+57log(F*/5.0)
More than** 7.5 MHz	50 or 55+10logP(W) (whichever is the lesser attenuation)
Emission mask M (Channel bandwidth 10 MHz)	
0 – 4.5 MHz	0***
4.5 – 5 MHz	568log(F*/4.5)
5 – 5.5 MHz	26+145log(F*/5.0)
5.5 – 10.0 MHz	32+31log(F*/5.5)
10.0 – 15 MHz	40+57log(F*/10.0)
More than** 15 MHz	50 or 55+10logP(W) (whichever is the lesser attenuation)

* - F – frequency in MHz removed from center

** - emission mask includes carrier modulation envelope within ± 150 % of the authorized bandwidth; the frequency range removed beyond ± 150 % of the authorized bandwidth from carrier was investigated as spurious emission

*** - Zero dB reference measured relative to the highest average power of the fundamental emission measured across designated channel bandwidth

7.4.2 Test procedure

7.4.2.1 The EUT was set up as shown in Figure 7.4.1, energized and its proper operation was checked.

7.4.2.2 The emission mask was measured with spectrum analyzer with RBW set to 100 kHz and VBW = 30 kHz as provided in the associated plots. The test results recorded in the associated tables.

Figure 7.4.1 Emission mask test setup

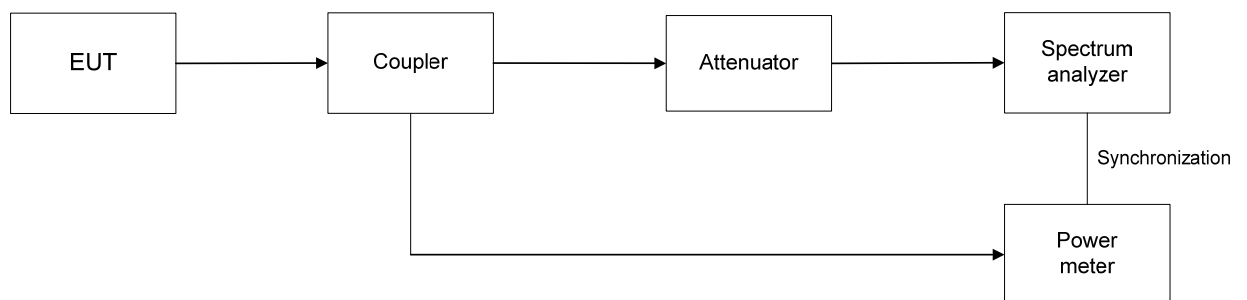



Test specification:		Section 90.210, Emission mask	
Test procedure:		47 CFR, Sections 2.1051, 2.1047 and 90.210(l); TIA/EIA-603-C, Section 2.2.13	
Test mode:		Compliance	
Date(s):		8/26/2012 - 8/30/2012	
Temperature: 24 °C		Air Pressure: 1006 hPa	
Remarks:		Relative Humidity: 48 %	
		Power Supply: 48 VDC	
Verdict: PASS			

Table 7.4.2 Emission mask test results QPSK modulation

Carrier frequency, MHz	Limit	Reference to Plot	Verdict
5 MHz			
4942.5	Emission mask M	7.4.7	Pass
4962.5		7.4.9	
4987.5		7.4.11	
10 MHz			
4947.5	Emission mask M	7.4.1	Pass
4962.5		7.4.3	
4982.5		7.4.5	

Table 7.4.3 Emission mask test results 64 QAM modulation

Carrier frequency, MHz	Limit	Reference to Plot	Verdict
5 MHz			
4942.5	Emission mask M	7.4.8	Pass
4962.5		7.4.10	
4987.5		7.4.12	
10 MHz			
4947.5	Emission mask M	7.4.2	Pass
4962.5		7.4.4	
4982.5		7.4.6	

Reference numbers of test equipment used

HL 3818	HL 3901						
---------	---------	--	--	--	--	--	--

Full description is given in Appendix A.



HERMON LABORATORIES

Test specification:	Section 90.210, Emission mask		
Test procedure:	47 CFR, Sections 2.1051, 2.1047 and 90.210(l); TIA/EIA-603-C, Section 2.2.13		
Test mode:	Compliance	Verdict:	PASS
Date(s):	8/26/2012 - 8/30/2012		
Temperature: 24 °C	Air Pressure: 1006 hPa	Relative Humidity: 48 %	Power Supply: 48 VDC
Remarks:			

Plot 7.4.1 Emission mask test results at low carrier frequency

MODULATION: QPSK
CHANNEL BANDWIDTH: 10

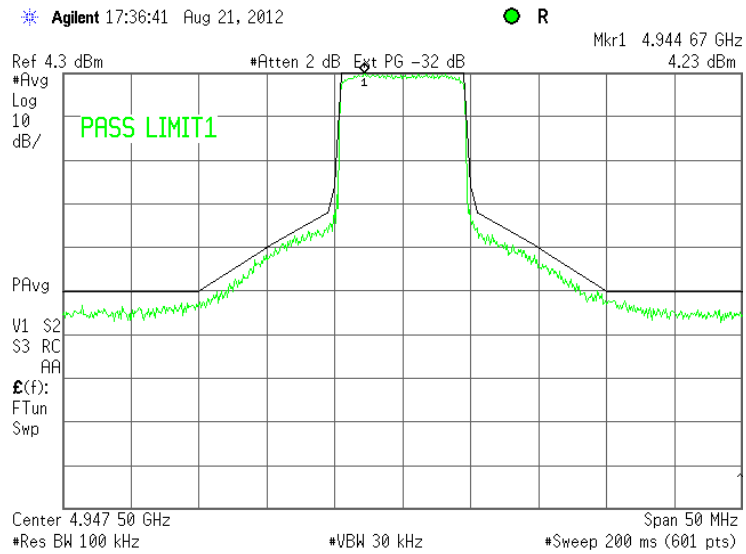

Plot 7.4.2 Emission mask test results at low carrier frequency

MODULATION: 64QAM
CHANNEL BANDWIDTH: 10

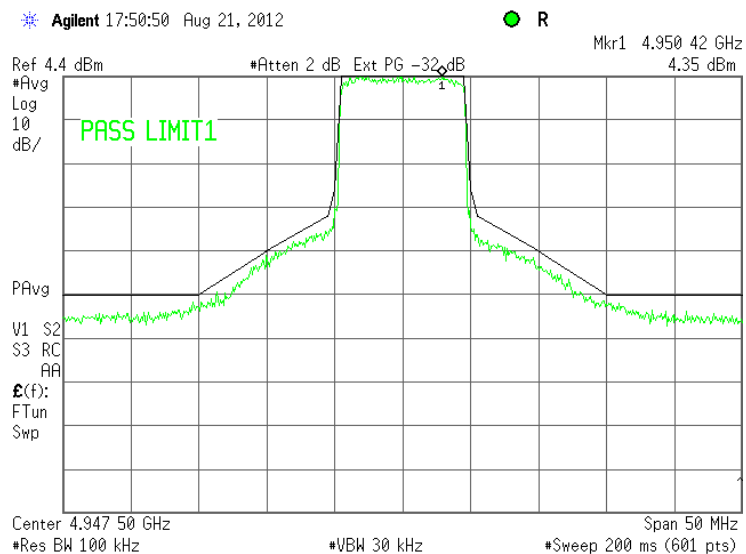



HERMON LABORATORIES

Test specification:	Section 90.210, Emission mask		
Test procedure:	47 CFR, Sections 2.1051, 2.1047 and 90.210(l); TIA/EIA-603-C, Section 2.2.13		
Test mode:	Compliance	Verdict:	PASS
Date(s):	8/26/2012 - 8/30/2012		
Temperature: 24 °C	Air Pressure: 1006 hPa	Relative Humidity: 48 %	Power Supply: 48 VDC
Remarks:			

Plot 7.4.3 Emission mask test results at mid carrier frequency

MODULATION:
CHANNEL BANDWIDTH:

QPSK
10

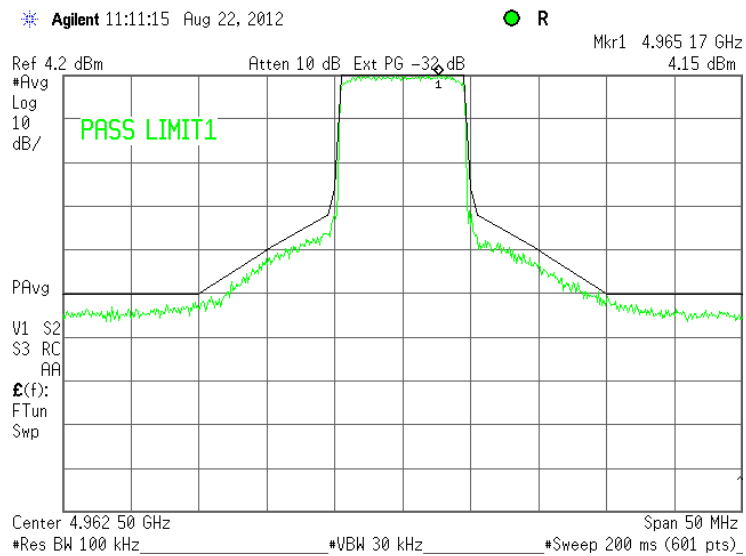

Plot 7.4.4 Emission mask test results at mid carrier frequency

MODULATION:
CHANNEL BANDWIDTH:

64 QAM
10

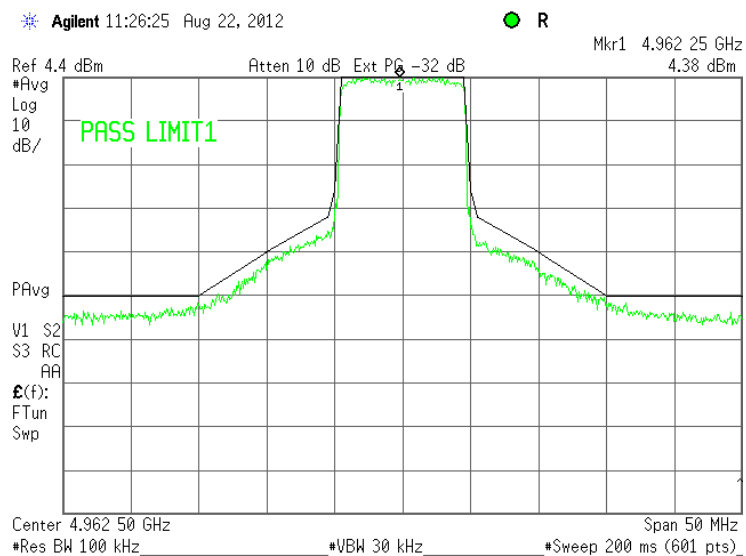



HERMON LABORATORIES

Test specification:	Section 90.210, Emission mask		
Test procedure:	47 CFR, Sections 2.1051, 2.1047 and 90.210(l); TIA/EIA-603-C, Section 2.2.13		
Test mode:	Compliance	Verdict:	PASS
Date(s):	8/26/2012 - 8/30/2012		
Temperature: 24 °C	Air Pressure: 1006 hPa	Relative Humidity: 48 %	Power Supply: 48 VDC
Remarks:			

Plot 7.4.5 Emission mask test results at high carrier frequency

MODULATION:
CHANNEL BANDWIDTH:

QPSK
10

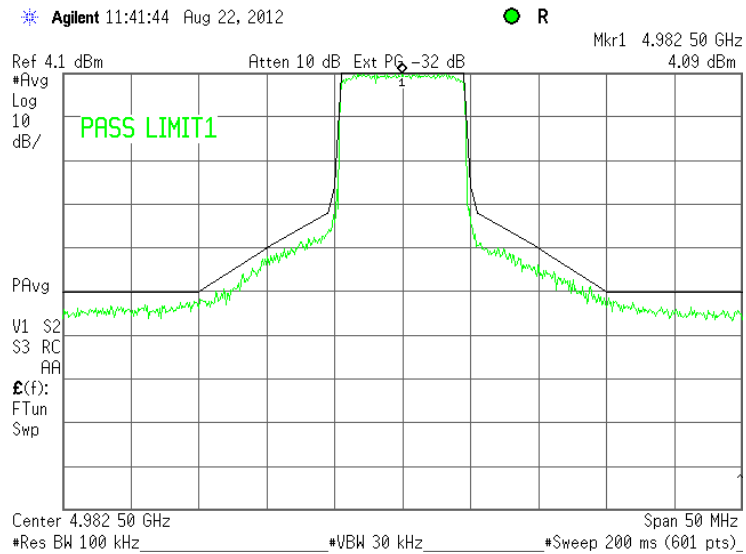

Plot 7.4.6 Emission mask test results at high carrier frequency

MODULATION:
CHANNEL BANDWIDTH:

64 QAM
10

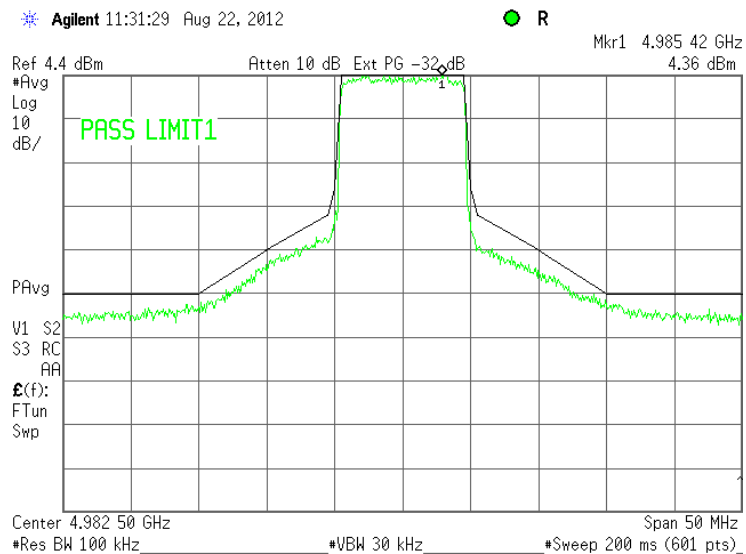



HERMON LABORATORIES

Test specification:	Section 90.210, Emission mask		
Test procedure:	47 CFR, Sections 2.1051, 2.1047 and 90.210(l); TIA/EIA-603-C, Section 2.2.13		
Test mode:	Compliance	Verdict:	PASS
Date(s):	8/26/2012 - 8/30/2012		
Temperature: 24 °C	Air Pressure: 1006 hPa	Relative Humidity: 48 %	Power Supply: 48 VDC
Remarks:			

Plot 7.4.7 Emission mask test results at low carrier frequency

MODULATION:
CHANNEL BANDWIDTH:

QPSK
5

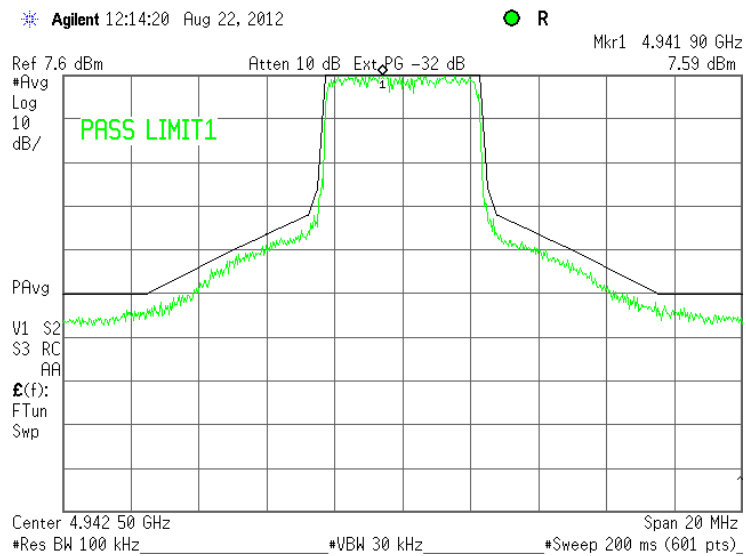

Plot 7.4.8 Emission mask test results at low carrier frequency

MODULATION:
CHANNEL BANDWIDTH:

64 QAM
5

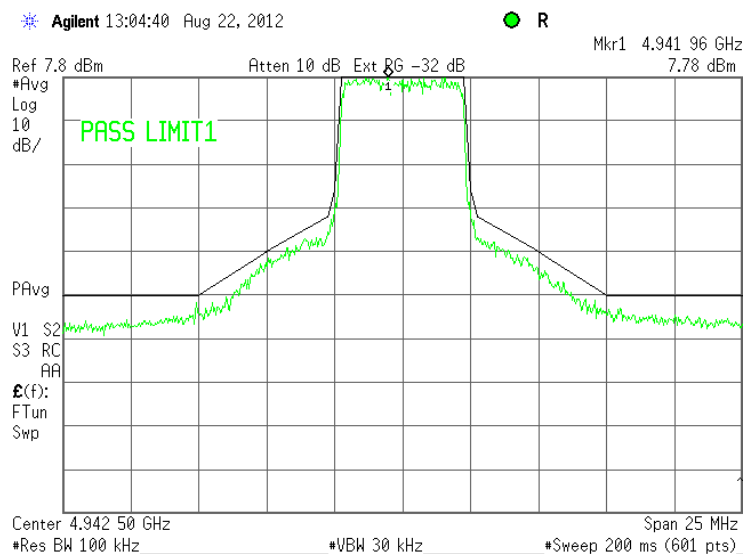



HERMON LABORATORIES

Test specification:	Section 90.210, Emission mask		
Test procedure:	47 CFR, Sections 2.1051, 2.1047 and 90.210(l); TIA/EIA-603-C, Section 2.2.13		
Test mode:	Compliance	Verdict:	PASS
Date(s):	8/26/2012 - 8/30/2012		
Temperature: 24 °C	Air Pressure: 1006 hPa	Relative Humidity: 48 %	Power Supply: 48 VDC
Remarks:			

Plot 7.4.9 Emission mask test results at mid carrier frequency

MODULATION:
CHANNEL BANDWIDTH:

QPSK
5

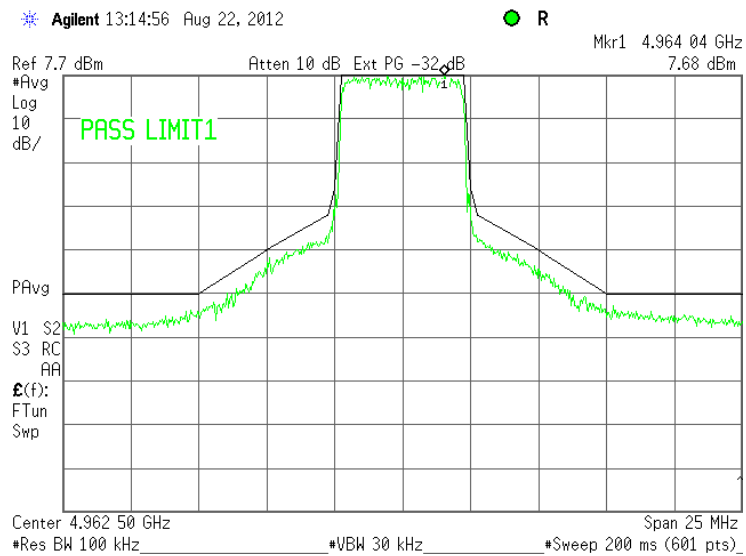

Plot 7.4.10 Emission mask test results at mid carrier frequency

MODULATION:
CHANNEL BANDWIDTH:

64 QAM
5

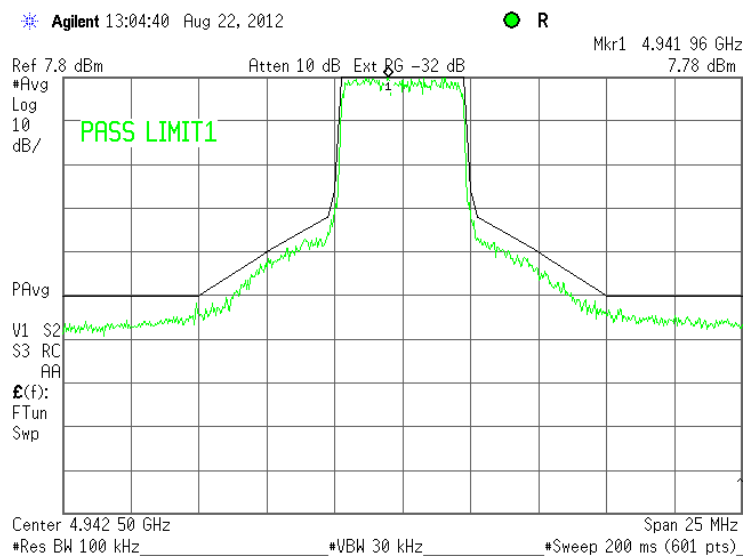



HERMON LABORATORIES

Test specification:	Section 90.210, Emission mask		
Test procedure:	47 CFR, Sections 2.1051, 2.1047 and 90.210(l); TIA/EIA-603-C, Section 2.2.13		
Test mode:	Compliance	Verdict:	PASS
Date(s):	8/26/2012 - 8/30/2012		
Temperature: 24 °C	Air Pressure: 1006 hPa	Relative Humidity: 48 %	Power Supply: 48 VDC
Remarks:			

Plot 7.4.11 Emission mask test results at high carrier frequency

MODULATION:
CHANNEL BANDWIDTH:

QPSK
5

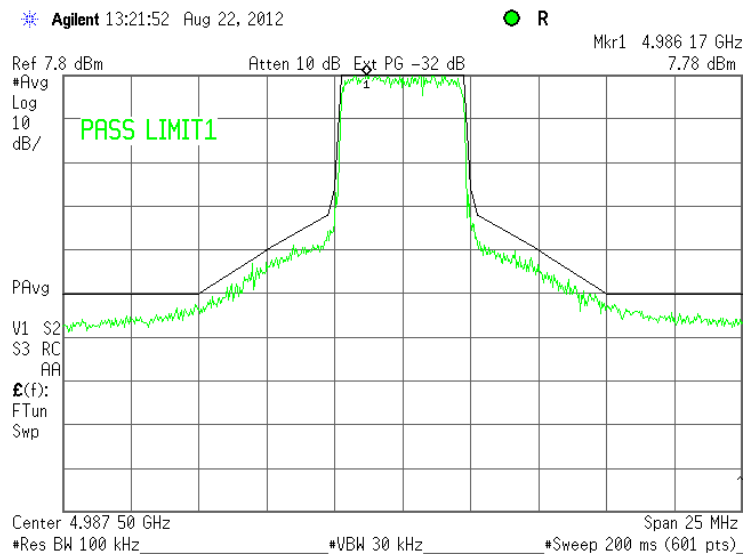

Plot 7.4.12 Emission mask test results at high carrier frequency

MODULATION:
CHANNEL BANDWIDTH:

64 QAM
5

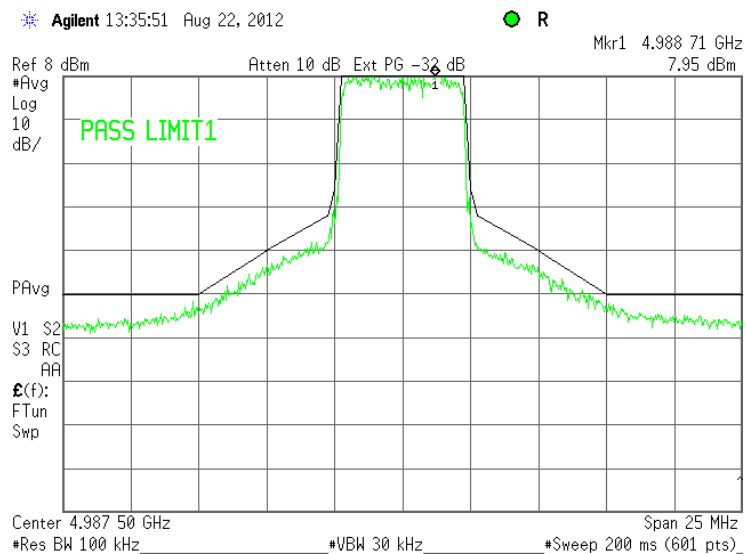



Test specification:	Section 90.210(l), 90.210(m), Spurious emissions at RF antenna connector		
Test procedure:	47 CFR, Sections 2.1051, 90.210(m); TIA/EIA-603-C, Section 2.2.13		
Test mode:	Compliance	Verdict:	PASS
Date(s):	8/22/2012		
Temperature: 24 °C	Air Pressure: 1006 hPa	Relative Humidity: 45 %	Power Supply: 48 VDC
Remarks:			

7.5 Spurious emissions at RF antenna connector test

7.5.1 General

This test was performed to measure spurious emissions at RF antenna connector. Specification test limits are given in Table 7.5.1.

Table 7.5.1 Spurious emission limits

Frequency, MHz	Attenuation below carrier, dBc	ERP of spurious, dBm
High power device		
0.009 – 40000*	50 or 55+10logP** (mask M, lesser attenuation)	-25.0

* - spurious emission limits do not apply to the in band emission within ± 150 % of the authorized bandwidth from the carrier; investigated in course of emission mask testing

** - P is transmitter output power in Watts

7.5.2 Test procedure

7.5.2.1 The EUT was set up as shown in Figure 7.5.1, energized and its proper operation was checked.

7.5.2.2 The EUT was adjusted to produce maximum available for end user RF output power.

7.5.2.3 The spurious emission was measured with spectrum analyzer as provided in Table 7.5.2 and the associated plots.

Figure 7.5.1 Spurious emission test setup for individual Tx chain

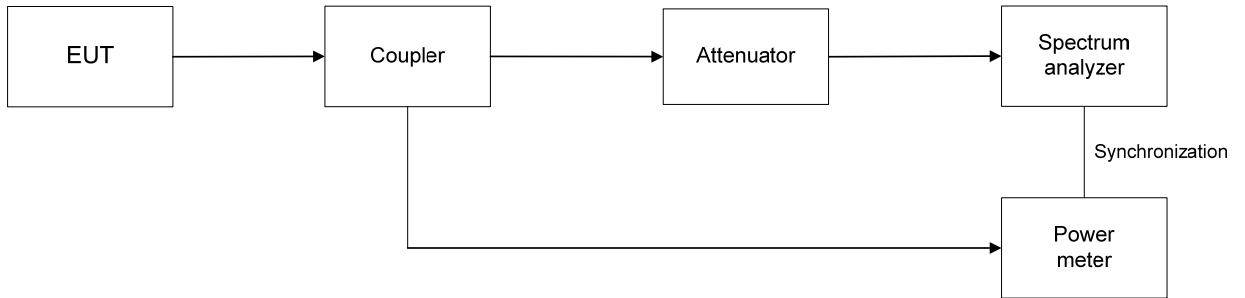



Test specification:	Section 90.210(l), 90.210(m), Spurious emissions at RF antenna connector		
Test procedure:	47 CFR, Sections 2.1051, 90.210(m); TIA/EIA-603-C, Section 2.2.13		
Test mode:	Compliance	Verdict: PASS	
Date(s):	8/22/2012		
Temperature: 24 °C	Air Pressure: 1006 hPa	Relative Humidity: 45 %	Power Supply: 48 VDC
Remarks:			

Table 7.5.2 Spurious emission test results

ASSIGNED FREQUENCY RANGE:	4940-4990 MHz
INVESTIGATED FREQUENCY RANGE:	0.009 – 40000 MHz
DETECTOR USED:	Peak
VIDEO BANDWIDTH:	≥ Resolution bandwidth
MODULATION:	64 QAM
MODULATING SIGNAL:	PRBS
CHANNEL BANDWIDTH:	5 MHz (Maximum output power spectral density)
TRANSMITTER OUTPUT POWER:	24.70 dBm at low frequency 24.52 dBm at mid frequency 24.30 dBm at high frequency

Frequency, MHz	SA reading, dBm	Attenuator, dB	Cable loss, dB	RBW, kHz	Spurious emission, dBm	Limit, dBm	Margin, dB*	Verdict
Low carrier frequency								
4829.9	-34.95	Included	Included	1000	-34.95	-25	-9.95	Pass
4935.0	-34.26	Included	Included	1000	-34.26	-25	-9.26	Pass
4950.1	-32.65	Included	Included	1000	-32.65	-25	-7.65	Pass
5075.0	-39.83	Included	Included	1000	-39.83	-25	-14.83	Pass
Mid carrier frequency								
4955.0	-35.53	Included	Included	1000	-35.53	-25	-10.53	Pass
4970.0	-33.13	Included	Included	1000	-33.13	-25	-8.13	Pass
5075.0	-40.26	Included	Included	1000	-40.26	-25	-15.26	Pass
High carrier frequency								
4852.8	-35.00	Included	Included	1000	-35.00	-25	-10.00	Pass
4995.2	-32.61	Included	Included	1000	-32.61	-25	-7.61	Pass
5000.0	-39.06	Included	Included	1000	-39.06	-25	-14.06	Pass

* - Margin = Spurious emission – specification limit.

Reference numbers of test equipment used

HL 3301	HL 3302	HL 3442	HL 3455	HL 3786	HL 3818	HL 3903	HL 4366
---------	---------	---------	---------	---------	---------	---------	---------

Full description is given in Appendix A.



HERMON LABORATORIES

Test specification:		Section 90.210(l), 90.210(m), Spurious emissions at RF antenna connector	
Test procedure:		47 CFR, Sections 2.1051, 90.210(m); TIA/EIA-603-C, Section 2.2.13	
Test mode:		Compliance	
Date(s):		8/22/2012	
Temperature: 24 °C		Air Pressure: 1006 hPa	
		Relative Humidity: 45 %	
		Power Supply: 48 VDC	
Remarks:			
		Verdict: PASS	

Plot 7.5.1 Spurious emission measurements in 9 - 150 kHz range at low, mid and high carrier frequency

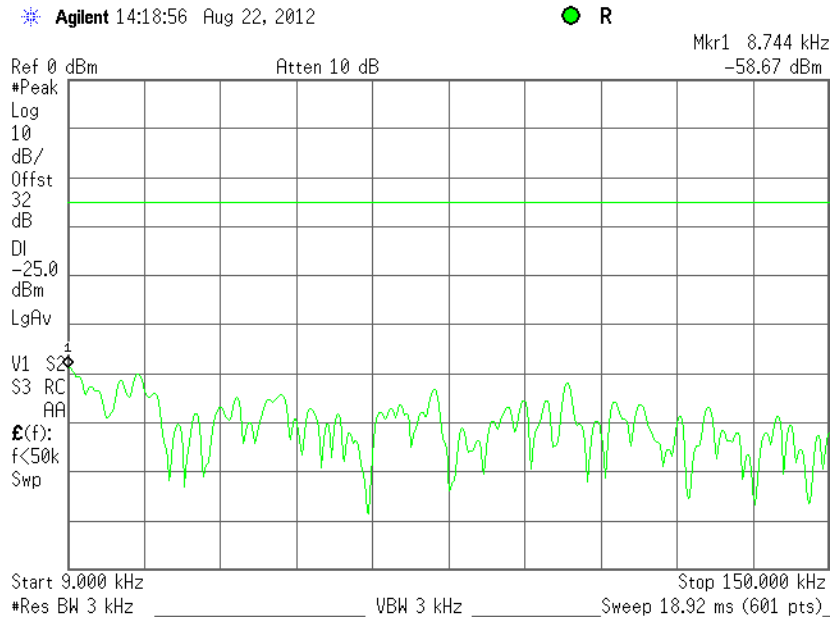

Plot 7.5.2 Spurious emission measurements in 0.150 - 30.0 MHz range at low, mid and high carrier frequency

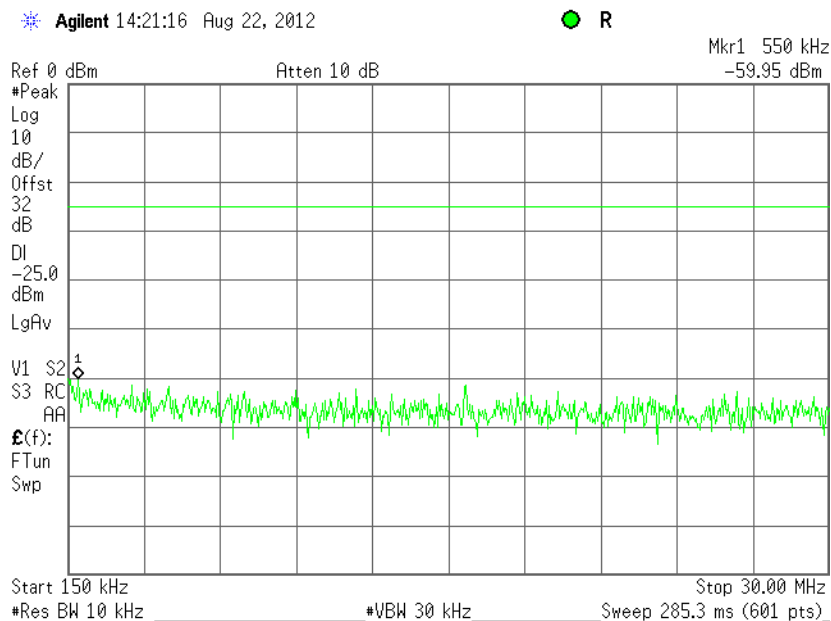



HERMON LABORATORIES

Test specification:		Section 90.210(l), 90.210(m), Spurious emissions at RF antenna connector	
Test procedure:		47 CFR, Sections 2.1051, 90.210(m); TIA/EIA-603-C, Section 2.2.13	
Test mode:		Compliance	
Date(s):		8/22/2012	
Temperature: 24 °C		Air Pressure: 1006 hPa	
		Relative Humidity: 45 %	
		Power Supply: 48 VDC	
Remarks:			

Plot 7.5.3 Spurious emission measurements in 30.0 - 1000 MHz range at low, mid and high carrier frequency

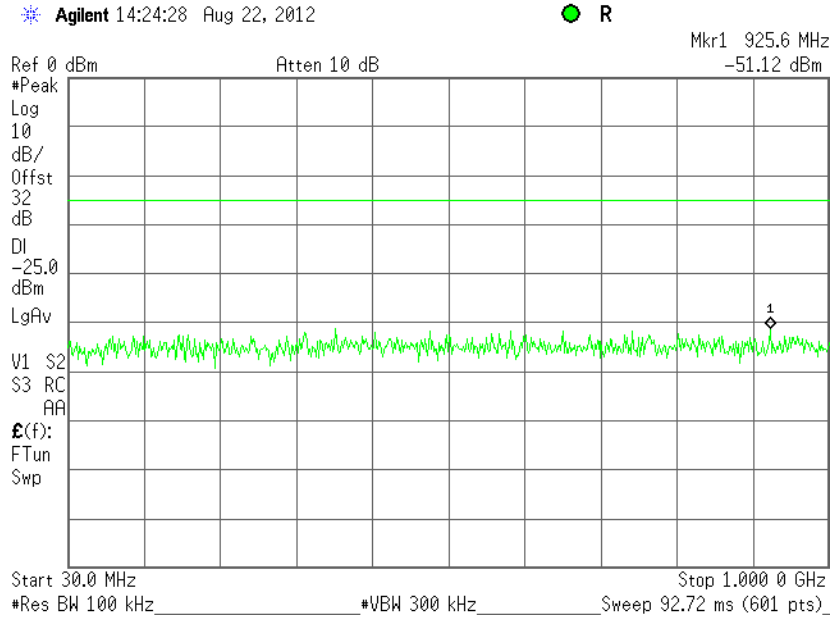

Plot 7.5.4 Spurious emission measurements in 1000 - 4500 MHz at low, mid and high carrier frequency

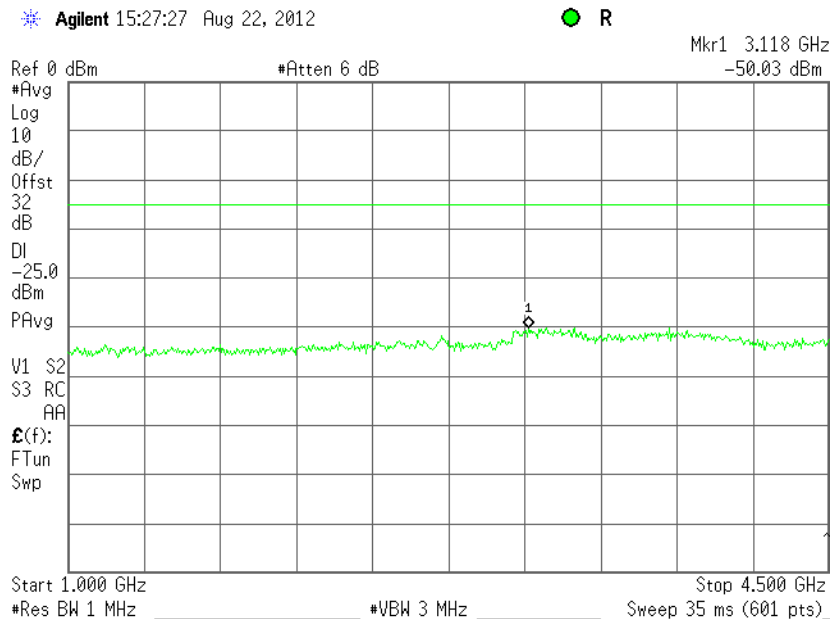



HERMON LABORATORIES

Test specification:		Section 90.210(l), 90.210(m), Spurious emissions at RF antenna connector	
Test procedure:		47 CFR, Sections 2.1051, 90.210(m); TIA/EIA-603-C, Section 2.2.13	
Test mode:		Compliance	
Date(s):		8/22/2012	
Temperature: 24 °C		Air Pressure: 1006 hPa	
		Relative Humidity: 45 %	
		Power Supply: 48 VDC	
Remarks:			
		Verdict: PASS	

Plot 7.5.5 Spurious emission measurements in 4500-4935 MHz range at low carrier frequency

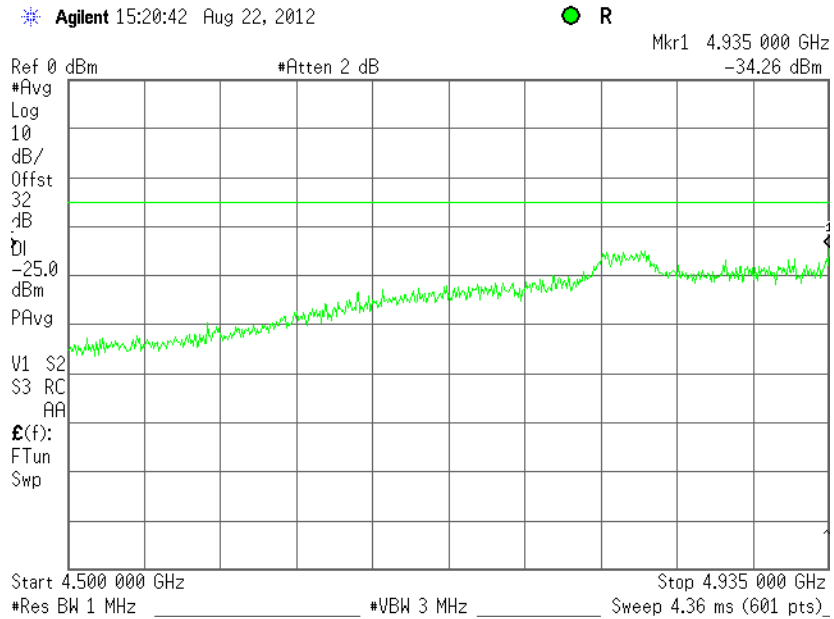

Plot 7.5.6 Spurious emission measurements in 4500-4955 MHz at mid carrier frequency

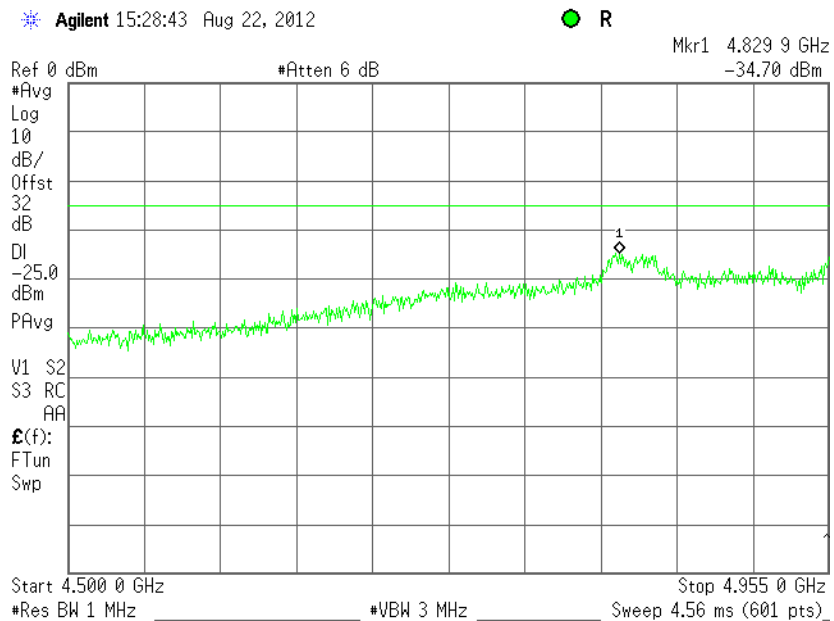



HERMON LABORATORIES

Test specification:	Section 90.210(l), 90.210(m), Spurious emissions at RF antenna connector		
Test procedure:	47 CFR, Sections 2.1051, 90.210(m); TIA/EIA-603-C, Section 2.2.13		
Test mode:	Compliance	Verdict:	PASS
Date(s):	8/22/2012		
Temperature: 24 °C	Air Pressure: 1006 hPa	Relative Humidity: 45 %	Power Supply: 48 VDC
Remarks:			

Plot 7.5.7 Spurious emission measurements in 4500-4980 MHz at high carrier frequency

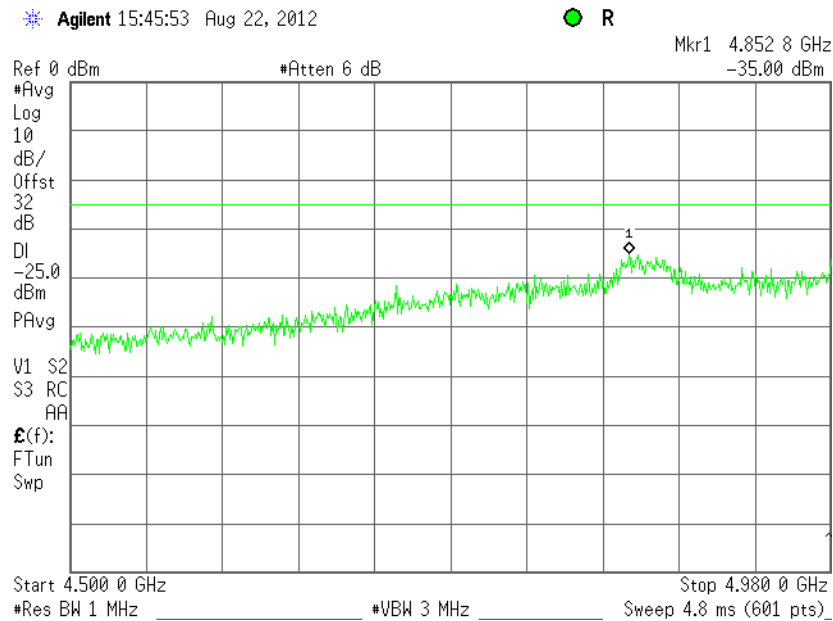

Plot 7.5.8 Spurious emission measurements in 4950-5000 MHz range at low carrier frequency

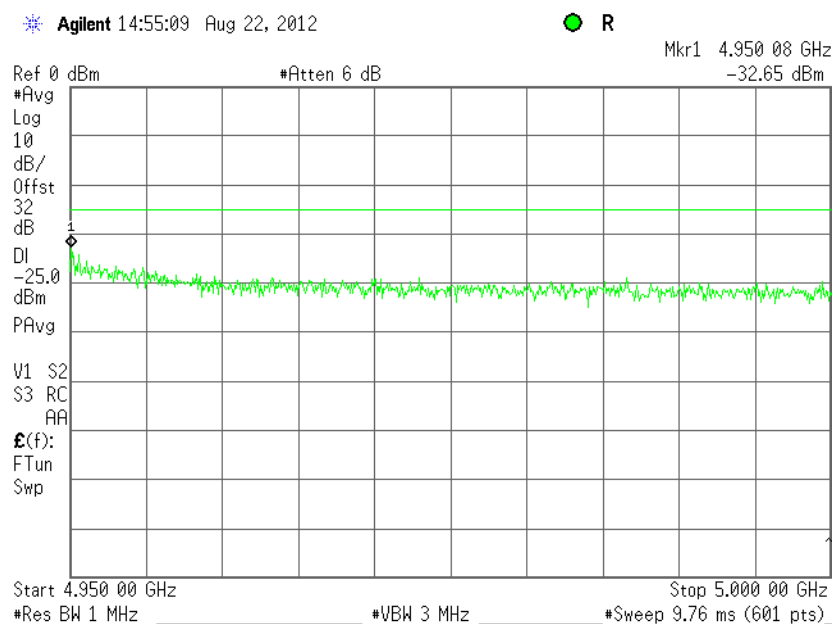



HERMON LABORATORIES

Test specification: Section 90.210(l), 90.210(m), Spurious emissions at RF antenna connector			
Test procedure: 47 CFR, Sections 2.1051, 90.210(m); TIA/EIA-603-C, Section 2.2.13			
Test mode: Compliance	Verdict: PASS		
Date(s): 8/22/2012			
Temperature: 24 °C	Air Pressure: 1006 hPa	Relative Humidity: 45 %	Power Supply: 48 VDC
Remarks:			

Plot 7.5.9 Spurious emission measurements in 4970-5000 MHz at mid carrier frequency

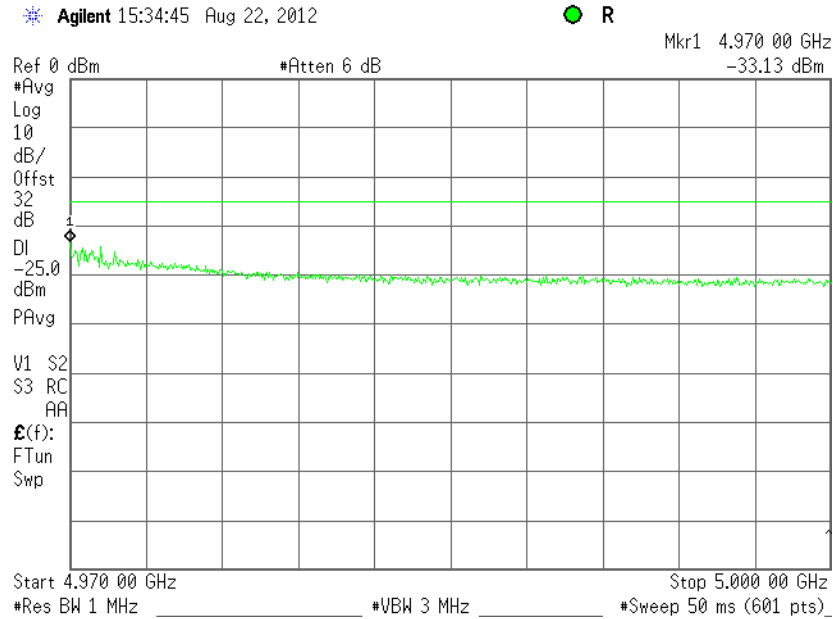

Plot 7.5.10 Spurious emission measurements in 4995 -5000 MHz at high carrier frequency

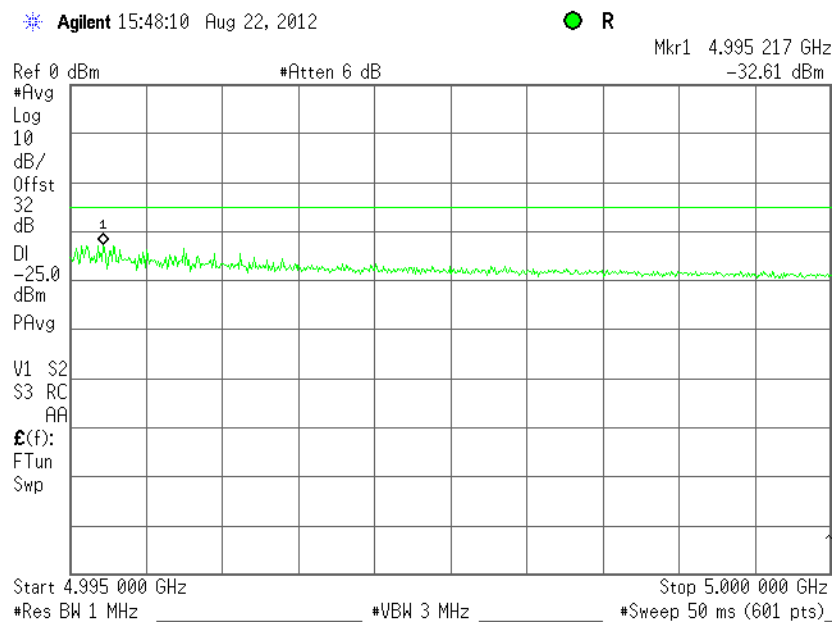



HERMON LABORATORIES

Test specification:	Section 90.210(l), 90.210(m), Spurious emissions at RF antenna connector		
Test procedure:	47 CFR, Sections 2.1051, 90.210(m); TIA/EIA-603-C, Section 2.2.13		
Test mode:	Compliance	Verdict:	PASS
Date(s):	8/22/2012		
Temperature: 24 °C	Air Pressure: 1006 hPa	Relative Humidity: 45 %	Power Supply: 48 VDC
Remarks:			

Plot 7.5.11 Spurious emission measurements in 5000-10000 MHz range at low carrier frequency

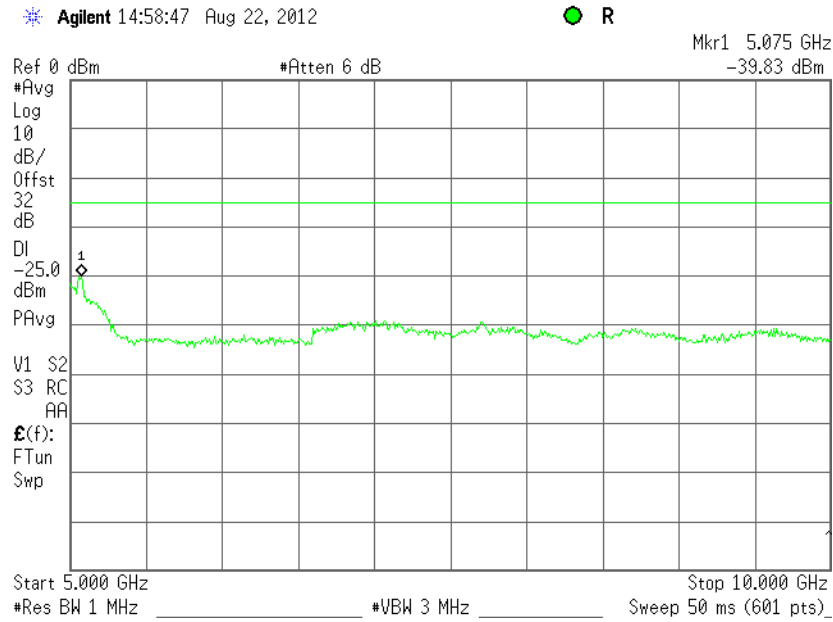

Plot 7.5.12 Spurious emission measurements in 5000-10000 MHz range at mid carrier frequency

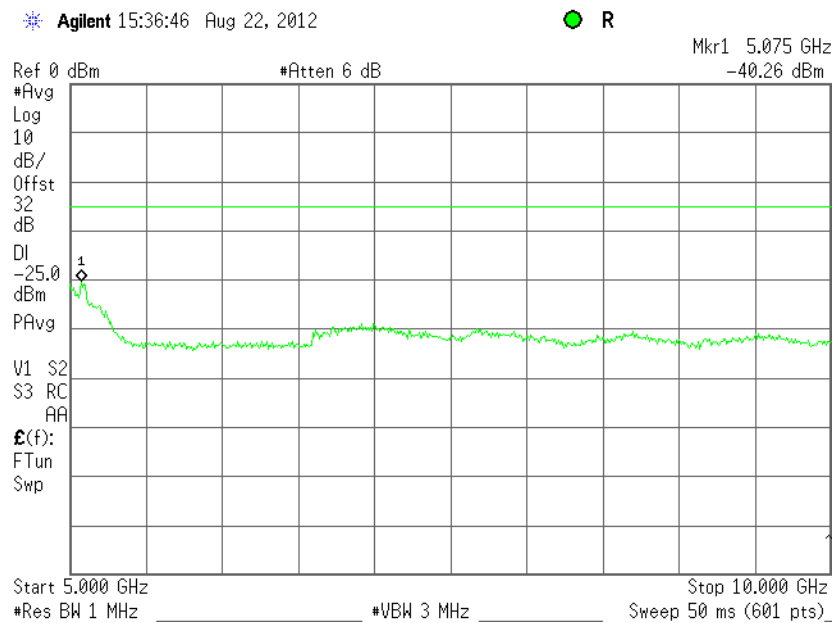



HERMON LABORATORIES

Test specification:	Section 90.210(l), 90.210(m), Spurious emissions at RF antenna connector		
Test procedure:	47 CFR, Sections 2.1051, 90.210(m); TIA/EIA-603-C, Section 2.2.13		
Test mode:	Compliance	Verdict:	PASS
Date(s):	8/22/2012	Relative Humidity:	45 %
Temperature: 24 °C	Air Pressure: 1006 hPa	Power Supply:	48 VDC
Remarks:			

Plot 7.5.13 Spurious emission measurements in 5000-10000 MHz range at high carrier frequency

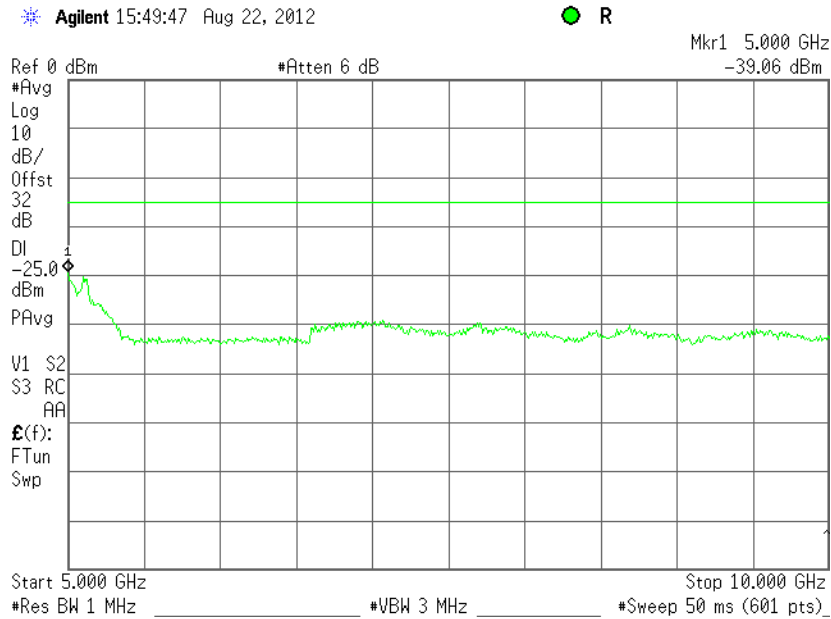

Plot 7.5.14 Spurious emission measurements in 10000-20000 MHz range at low carrier frequency

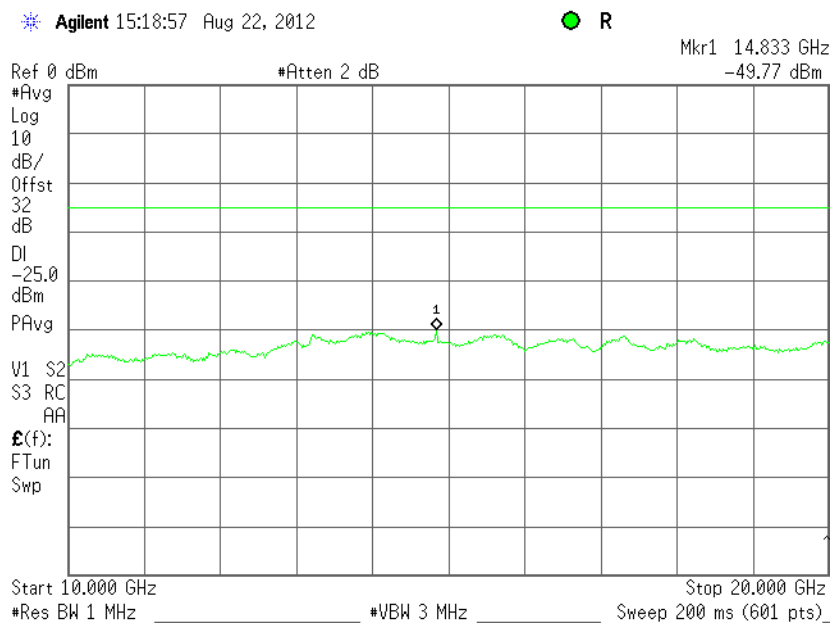



HERMON LABORATORIES

Test specification: Section 90.210(l), 90.210(m), Spurious emissions at RF antenna connector			
Test procedure: 47 CFR, Sections 2.1051, 90.210(m); TIA/EIA-603-C, Section 2.2.13			
Test mode: Compliance	Verdict: PASS		
Date(s): 8/22/2012			
Temperature: 24 °C	Air Pressure: 1006 hPa	Relative Humidity: 45 %	Power Supply: 48 VDC
Remarks:			

Plot 7.5.15 Spurious emission measurements in 10000-20000 MHz range at mid carrier frequency

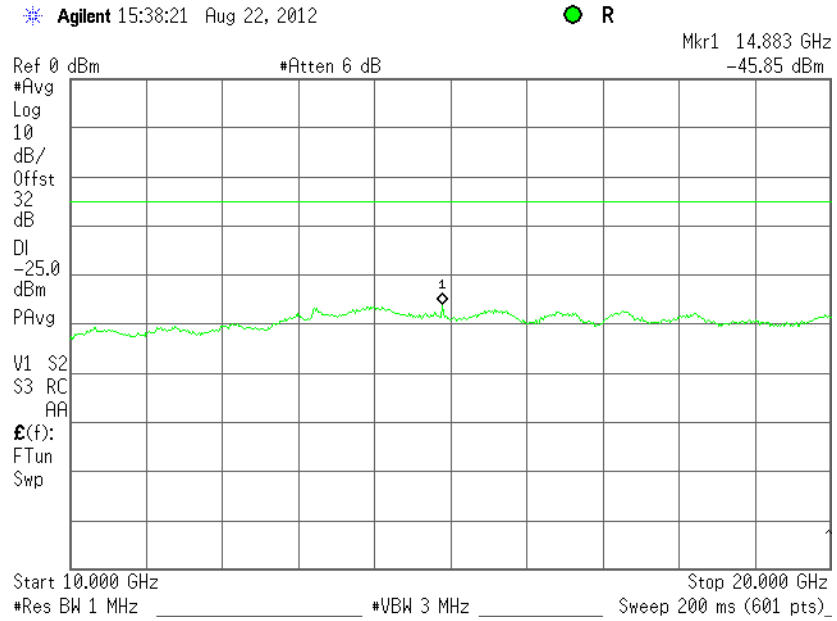

Plot 7.5.16 Spurious emission measurements in 10000-20000 MHz range at high carrier frequency

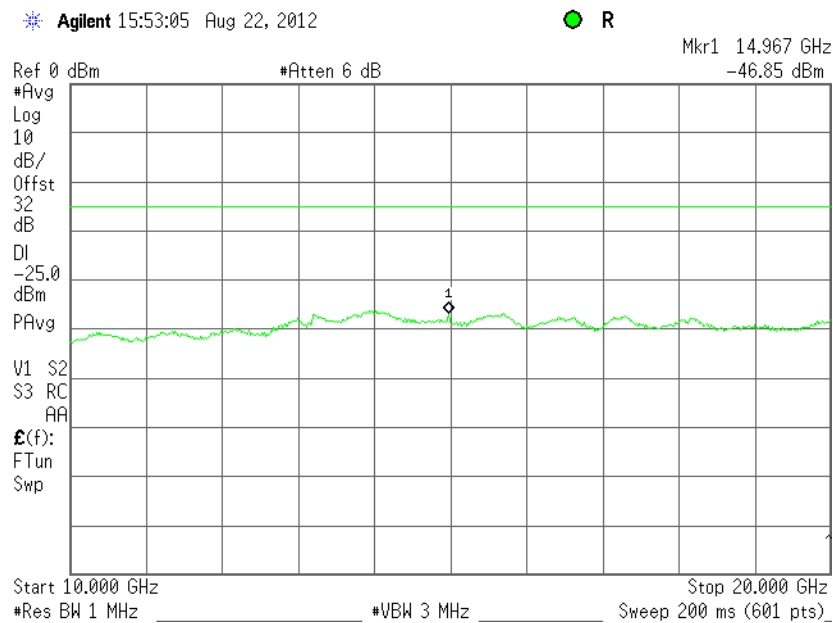



HERMON LABORATORIES

Test specification:	Section 90.210(l), 90.210(m), Spurious emissions at RF antenna connector		
Test procedure:	47 CFR, Sections 2.1051, 90.210(m); TIA/EIA-603-C, Section 2.2.13		
Test mode:	Compliance	Verdict:	PASS
Date(s):	8/22/2012		
Temperature: 24 °C	Air Pressure: 1006 hPa	Relative Humidity: 45 %	Power Supply: 48 VDC
Remarks:			

Plot 7.5.17 Spurious emission measurements in 20000 –30000 MHz range at low; mid; high carrier frequency

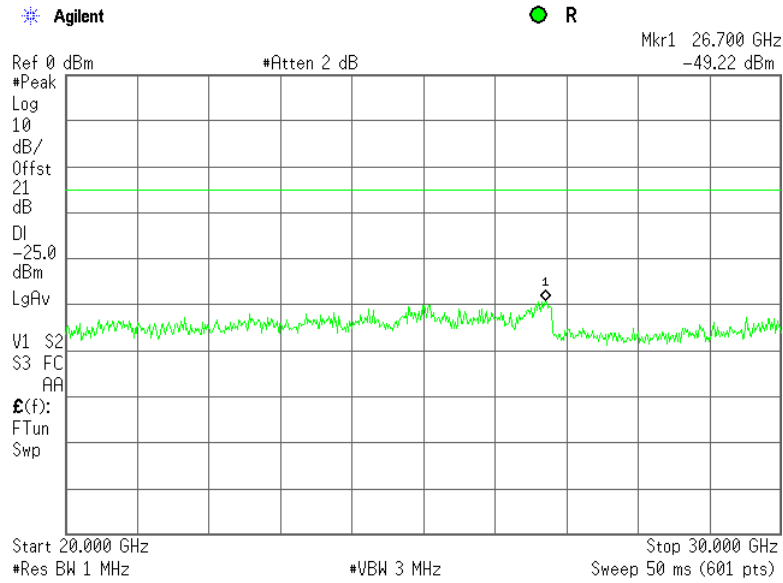

Plot 7.5.18 Spurious emission measurements in 30000 –40000 MHz range at low; mid; high carrier frequency

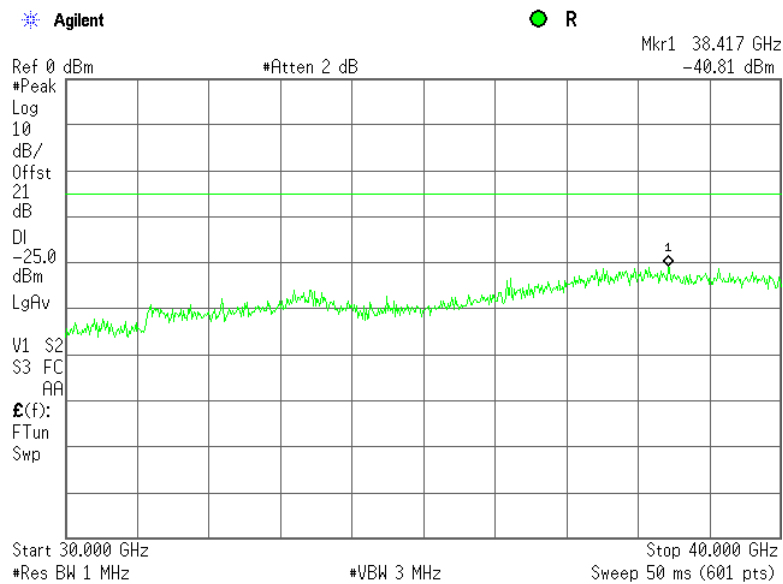



Test specification:	Section 90.210(l), 90.210(m), Radiated spurious emissions		
Test procedure:	47 CFR, Sections 2.1053, 90.210(m); TIA/EIA-603-C, Section 2.2.12		
Test mode:	Compliance	Verdict:	PASS
Date(s):	8/26/2012 - 8/30/2012		
Temperature: 24 °C	Air Pressure: 1006 hPa	Relative Humidity: 48 %	Power Supply: 48 VDC
Remarks:			

7.6 Radiated spurious emission measurements

7.6.1 General

This test was performed to measure radiated spurious emissions from the EUT. Specification test limits are given in Table 7.6.1.

Table 7.6.1 Radiated spurious emission test limits

Frequency, MHz	Attenuation below carrier, dBc	ERP of spurious, dBm	Equivalent field strength limit @ 3m, dB(μ V/m)**
High power device			
0.009 – 40000*	55+10logP	-25	72.40

ERP of spurious = P (dBm) - {55 + 10 log P (W)} = -25 dBm

* - Excluding the in band emission within ± 150 % of the authorized bandwidth from the carrier

** - Equivalent field strength limit was calculated from maximum allowed ERP of spurious as follows: $E = \sqrt{30 \times P \times 1.64} / r$, where P is ERP in Watts, 1.64 is numeric gain of ideal dipole and r is antenna to EUT distance in meters.

7.6.2 Test procedure for spurious emission field strength measurements in 9 kHz to 30 MHz band

7.6.2.1 The EUT was set up as shown in Figure 7.6.1, energized and the performance check was conducted.

7.6.2.2 The specified frequency range was investigated with antenna connected to spectrum analyzer. To find maximum radiation the turntable was rotated 360° and the measuring antenna was rotated around its vertical axis.

7.6.2.3 The worst test results (the lowest margins) were recorded in Table 7.6.2 and shown in the associated plots.

7.6.3 Test procedure for spurious emission field strength measurements above 30 MHz

7.6.3.1 The EUT was set up as shown in Figure 7.6.2, energized and the performance check was conducted.

7.6.3.2 The specified frequency range was investigated with antenna connected to spectrum analyzer. To find maximum radiation the turntable was rotated 360° and the measuring antenna height was swept from 1 to 4 m in both, vertical and horizontal, polarizations.

7.6.3.3 The worst test results (the lowest margins) were recorded in Table 7.6.2 and shown in the associated plots.



Test specification:	Section 90.210(l), 90.210(m), Radiated spurious emissions		
Test procedure:	47 CFR, Sections 2.1053, 90.210(m); TIA/EIA-603-C, Section 2.2.12		
Test mode:	Compliance	Verdict:	PASS
Date(s):	8/26/2012 - 8/30/2012		
Temperature: 24 °C	Air Pressure: 1006 hPa	Relative Humidity: 48 %	Power Supply: 48 VDC
Remarks:			

Figure 7.6.1 Setup for spurious emission field strength measurements in 9 kHz to 30 MHz band

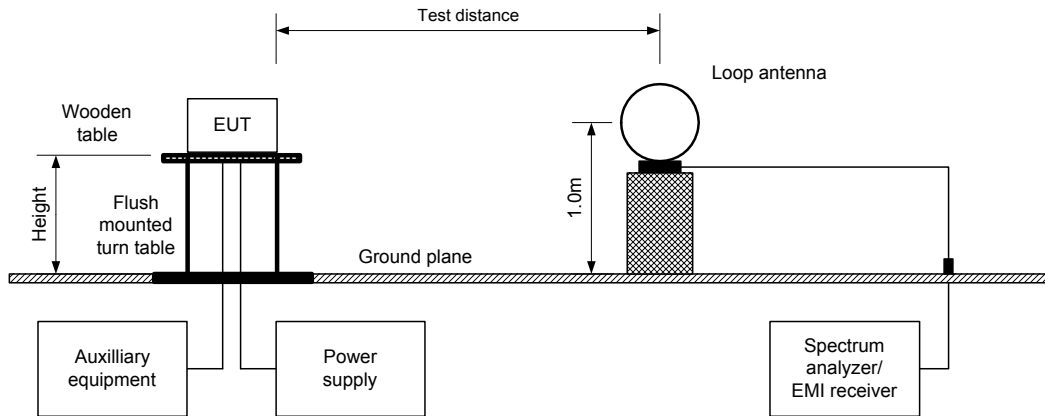
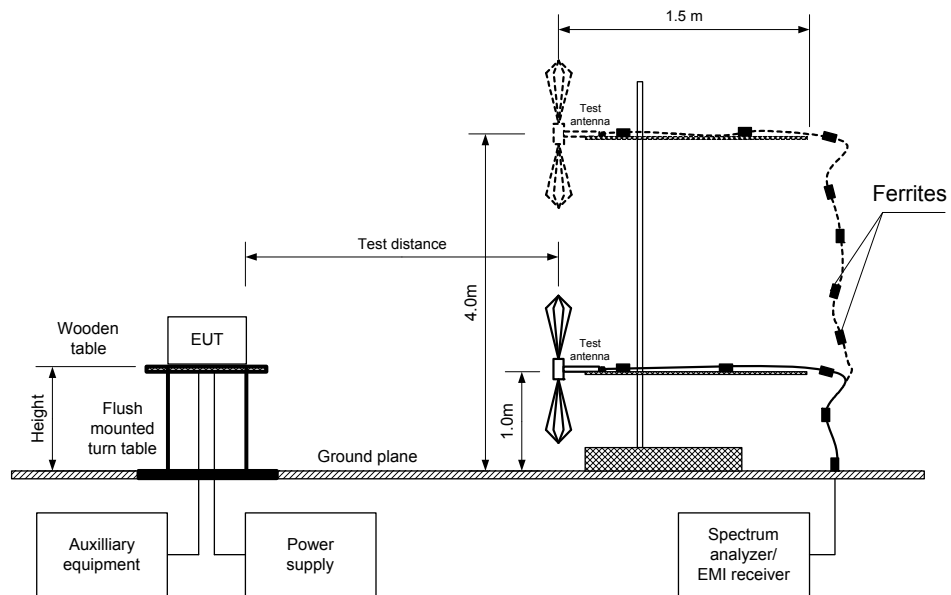

Figure 7.6.2 Setup for spurious emission field strength measurements above 30 MHz





Test specification:	Section 90.210(l), 90.210(m), Radiated spurious emissions		
Test procedure:	47 CFR, Sections 2.1053, 90.210(m); TIA/EIA-603-C, Section 2.2.12		
Test mode:	Compliance	Verdict: PASS	
Date(s):	8/26/2012 - 8/30/2012		
Temperature: 24 °C	Air Pressure: 1006 hPa	Relative Humidity: 48 %	Power Supply: 48 VDC
Remarks:			

Table 7.6.2 Spurious emission field strength test results

ASSIGNED FREQUENCY RANGE: 4940 - 4990 MHz
TEST DISTANCE: 3 m
TEST SITE: Semi anechoic chamber
EUT HEIGHT: 0.8 m
INVESTIGATED FREQUENCY RANGE: 0.009 – 40000 MHz
DETECTOR USED: Peak
VIDEO BANDWIDTH: > Resolution bandwidth
TEST ANTENNA TYPE: Active loop (9 kHz – 30 MHz)
Biconilog (30 MHz – 1000 MHz)
Double ridged guide (above 1000 MHz)

MODULATION: 64 QAM
MODULATING SIGNAL: PRBS
CHANNEL BANDWIDTH: 5 MHz
TRANSMITTER OUTPUT POWER SETTINGS: Maximum

Frequency, MHz	Field strength, dB(μV/m)	Limit, dB(μV/m)	Margin, dB*	RBW, kHz	Antenna polarization	Antenna height, m	Turn-table position**, degrees
No signals were found							

Verdict:Pass

*- Margin = Field strength of spurious – calculated field strength limit.

** - EUT front panel refers to 0 degrees position of turntable.

Reference numbers of test equipment used

HL 0446	HL 0521	HL 0604	HL 0768	HL 0769	HL 3533	HL 3535	HL 3901
HL 4114	HL 4352	HL 4353					

Full description is given in Appendix A.



HERMON LABORATORIES

Test specification:		Section 90.210(l), 90.210(m), Radiated spurious emissions	
Test procedure:		47 CFR, Sections 2.1053, 90.210(m); TIA/EIA-603-C, Section 2.2.12	
Test mode:		Verdict: PASS	
Date(s):		8/26/2012 - 8/30/2012	
Temperature: 24 °C	Air Pressure: 1006 hPa	Relative Humidity: 48 %	Power Supply: 48 VDC
Remarks:			

Plot 7.6.1 Radiated emission measurements in 9 - 150 kHz range

TEST SITE: Semi anechoic chamber
 CARRIER FREQUENCY: Low; mid; high
 ANTENNA POLARIZATION: Vertical and Horizontal
 TEST DISTANCE: 3 m



ACTV DET: PEAK
 MERS DET: PEAK QP AVG
 MKR 9.7 kHz
 63.31 dBµV/m

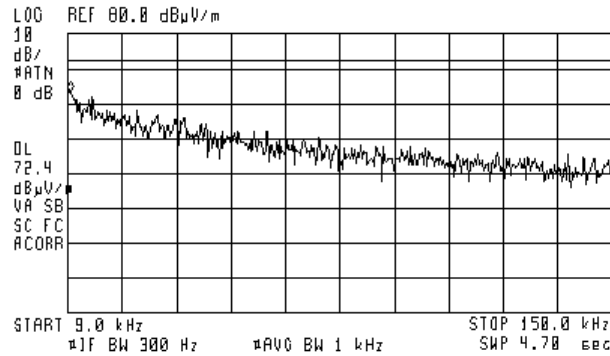

Plot 7.6.2 Radiated emission measurements in 0.15 - 30 MHz range

TEST SITE: Semi anechoic chamber
 CARRIER FREQUENCY: Low; mid; high
 ANTENNA POLARIZATION: Vertical and Horizontal
 TEST DISTANCE: 3 m



ACTV DET: PEAK
 MERS DET: PEAK QP AVG
 MKR 150 kHz
 61.48 dBµV/m

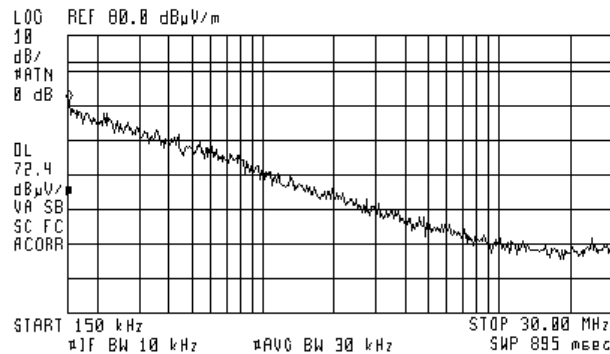



HERMON LABORATORIES

Test specification:	Section 90.210(l), 90.210(m), Radiated spurious emissions		
Test procedure:	47 CFR, Sections 2.1053, 90.210(m); TIA/EIA-603-C, Section 2.2.12		
Test mode:	Compliance	Verdict:	PASS
Date(s):	8/26/2012 - 8/30/2012		
Temperature: 24 °C	Air Pressure: 1006 hPa	Relative Humidity: 48 %	Power Supply: 48 VDC
Remarks:			

Plot 7.6.3 Radiated emission measurements in 30 - 1000 MHz range

TEST SITE: Semi anechoic chamber 3m
 ANTENNA POLARIZATION: Vertical
 CARRIER FREQUENCY: Low; mid; high



ACTV DET: PEAK
 MERS DET: PEAK QP AVG
 MKR 166.5 MHz
 41.16 dBµV/m

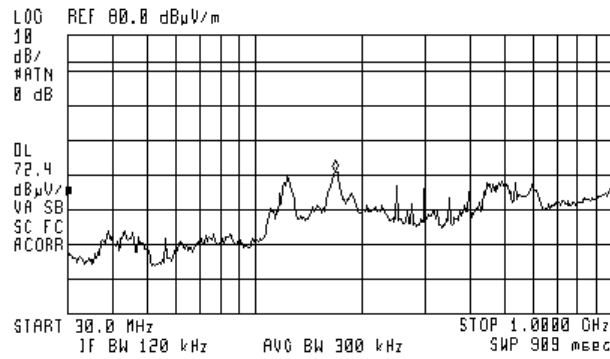

Plot 7.6.4 Radiated emission measurements in 30 - 1000 MHz range

TEST SITE: Semi anechoic chamber 3m
 ANTENNA POLARIZATION: Horizontal
 CARRIER FREQUENCY: Low; mid; high



ACTV DET: PEAK
 MERS DET: PEAK QP AVG
 MKR 501.2 MHz
 41.94 dBµV/m

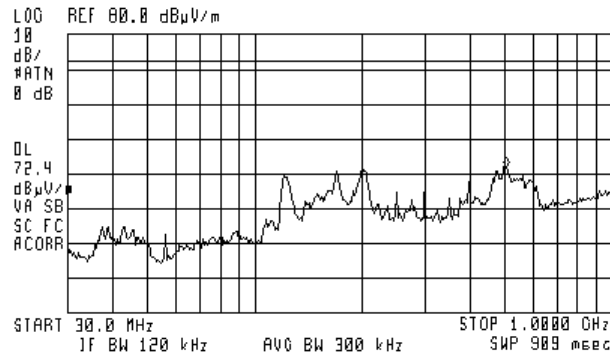



HERMON LABORATORIES

Test specification:		Section 90.210(l), 90.210(m), Radiated spurious emissions	
Test procedure:		47 CFR, Sections 2.1053, 90.210(m); TIA/EIA-603-C, Section 2.2.12	
Test mode:		Verdict: PASS	
Date(s):		8/26/2012 - 8/30/2012	
Temperature: 24 °C	Air Pressure: 1006 hPa	Relative Humidity: 48 %	Power Supply: 48 VDC
Remarks:			

Plot 7.6.5 Radiated emission measurements in 1000 – 2900 MHz range

TEST SITE: Semi anechoic chamber
 CARRIER FREQUENCY: Low; mid; high
 ANTENNA POLARIZATION: Vertical and Horizontal
 TEST DISTANCE: 3 m



ACTV DET: PEAK
 MERS DET: PEAK OP AVG
 MKR 2.829 GHz
 51.00 dB μ V/m

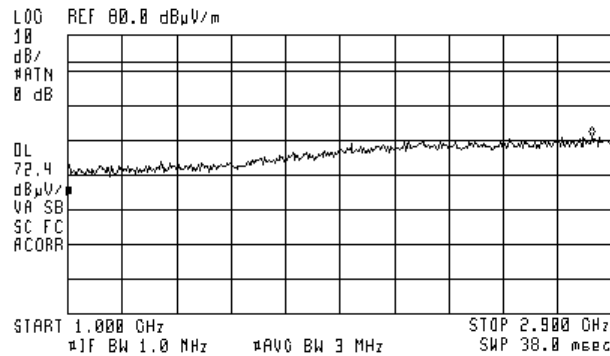

Plot 7.6.6 Radiated emission measurements in 2900 – 4935 MHz range

TEST SITE: Semi anechoic chamber
 CARRIER FREQUENCY: Low
 ANTENNA POLARIZATION: Vertical and Horizontal
 TEST DISTANCE: 3 m

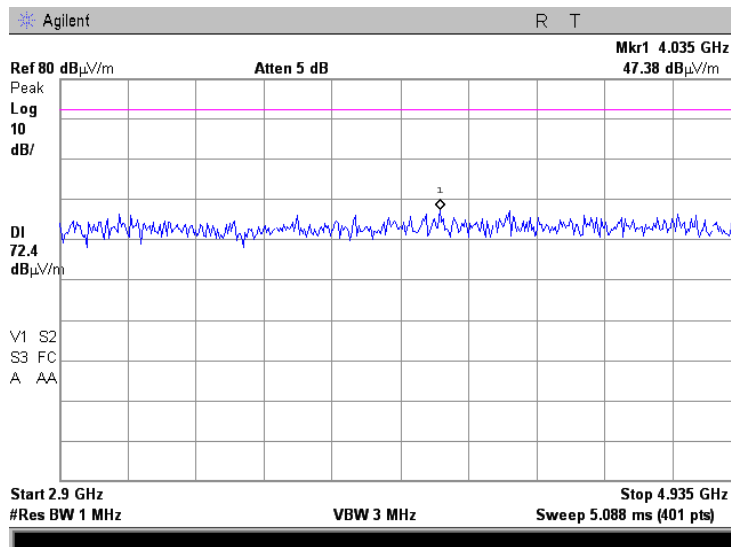



Test specification:	Section 90.210(l), 90.210(m), Radiated spurious emissions		
Test procedure:	47 CFR, Sections 2.1053, 90.210(m); TIA/EIA-603-C, Section 2.2.12		
Test mode:	Compliance	Verdict:	PASS
Date(s):	8/26/2012 - 8/30/2012		
Temperature: 24 °C	Air Pressure: 1006 hPa	Relative Humidity: 48 %	Power Supply: 48 VDC
Remarks:			

Plot 7.6.7 Radiated emission measurements in 4935-4950 MHz range

TEST SITE: Semi anechoic chamber
 CARRIER FREQUENCY: Low
 ANTENNA POLARIZATION: Vertical and Horizontal
 TEST DISTANCE: 3 m

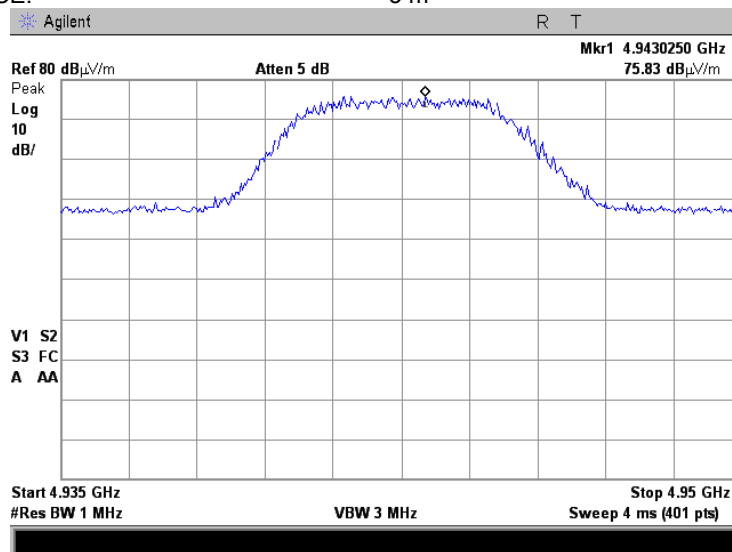

Plot 7.6.8 Radiated emission measurements in 4950 – 8000 MHz range

TEST SITE: Semi anechoic chamber
 CARRIER FREQUENCY: Low
 ANTENNA POLARIZATION: Vertical and Horizontal
 TEST DISTANCE: 3 m

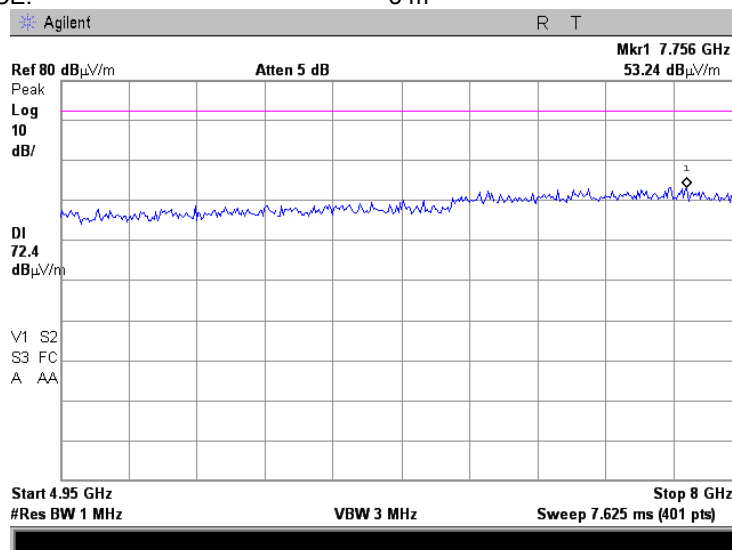



Test specification:	Section 90.210(l), 90.210(m), Radiated spurious emissions		
Test procedure:	47 CFR, Sections 2.1053, 90.210(m); TIA/EIA-603-C, Section 2.2.12		
Test mode:	Compliance	Verdict:	PASS
Date(s):	8/26/2012 - 8/30/2012		
Temperature: 24 °C	Air Pressure: 1006 hPa	Relative Humidity: 48 %	Power Supply: 48 VDC
Remarks:			

Plot 7.6.9 Radiated emission measurements in 2900 – 4955 MHz range

TEST SITE: Semi anechoic chamber
 CARRIER FREQUENCY: Mid
 ANTENNA POLARIZATION: Vertical and Horizontal
 TEST DISTANCE: 3 m

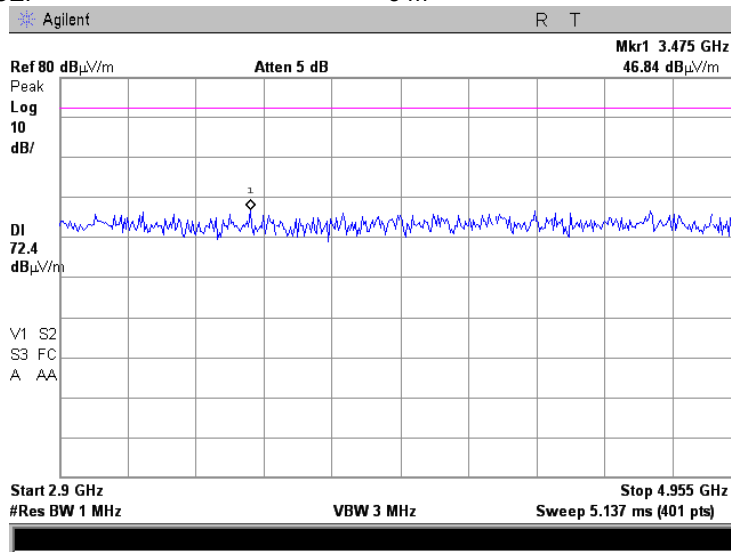

Plot 7.6.10 Radiated emission measurements in 4955 – 4970 MHz range

TEST SITE: Semi anechoic chamber
 CARRIER FREQUENCY: Mid
 ANTENNA POLARIZATION: Vertical and Horizontal
 TEST DISTANCE: 3 m

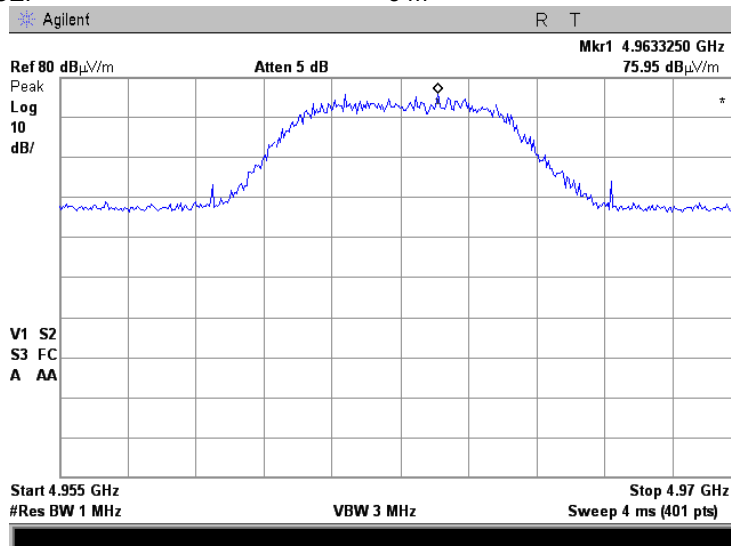



HERMON LABORATORIES

Test specification:		Section 90.210(l), 90.210(m), Radiated spurious emissions	
Test procedure:		47 CFR, Sections 2.1053, 90.210(m); TIA/EIA-603-C, Section 2.2.12	
Test mode:		Verdict: PASS	
Date(s):		8/26/2012 - 8/30/2012	
Temperature: 24 °C	Air Pressure: 1006 hPa	Relative Humidity: 48 %	Power Supply: 48 VDC
Remarks:			

Plot 7.6.11 Radiated emission measurements in 4970 – 8000 MHz range

TEST SITE: Semi anechoic chamber
 CARRIER FREQUENCY: Mid
 ANTENNA POLARIZATION: Vertical and Horizontal
 TEST DISTANCE: 3 m

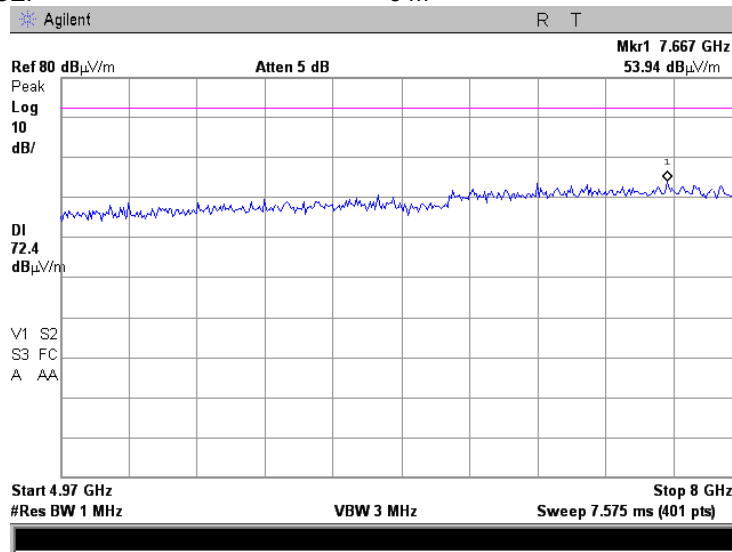

Plot 7.6.12 Radiated emission measurements in 2900-4980 MHz range

TEST SITE: Semi anechoic chamber
 CARRIER FREQUENCY: High
 ANTENNA POLARIZATION: Vertical and Horizontal
 TEST DISTANCE: 3 m

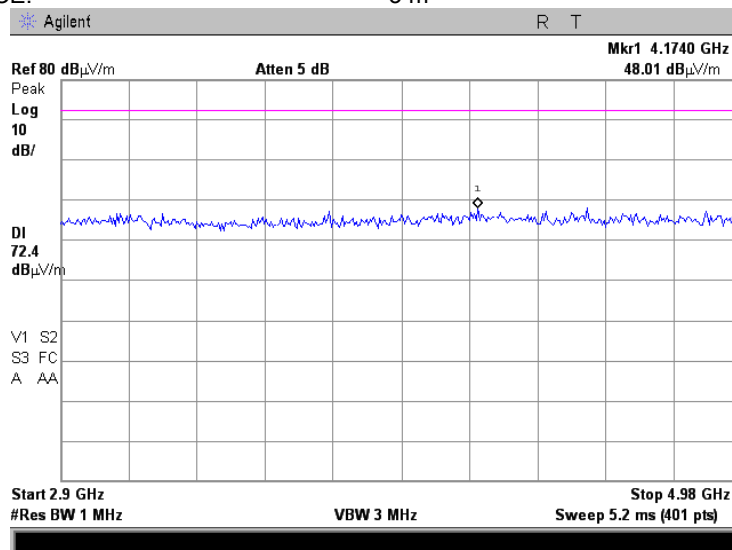



Test specification:	Section 90.210(l), 90.210(m), Radiated spurious emissions		
Test procedure:	47 CFR, Sections 2.1053, 90.210(m); TIA/EIA-603-C, Section 2.2.12		
Test mode:	Compliance	Verdict:	PASS
Date(s):	8/26/2012 - 8/30/2012		
Temperature: 24 °C	Air Pressure: 1006 hPa	Relative Humidity: 48 %	Power Supply: 48 VDC
Remarks:			

Plot 7.6.13 Radiated emission measurements in 4980-4995 MHz range

TEST SITE: Semi anechoic chamber
 CARRIER FREQUENCY: High
 ANTENNA POLARIZATION: Vertical and Horizontal
 TEST DISTANCE: 3 m

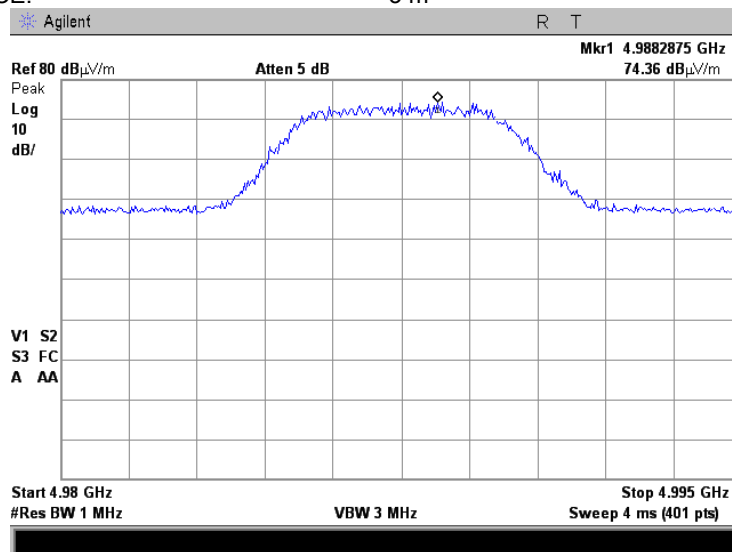

Plot 7.6.14 Radiated emission measurements in 4995-8000 MHz range

TEST SITE: Semi anechoic chamber
 CARRIER FREQUENCY: High
 ANTENNA POLARIZATION: Vertical and Horizontal
 TEST DISTANCE: 3 m

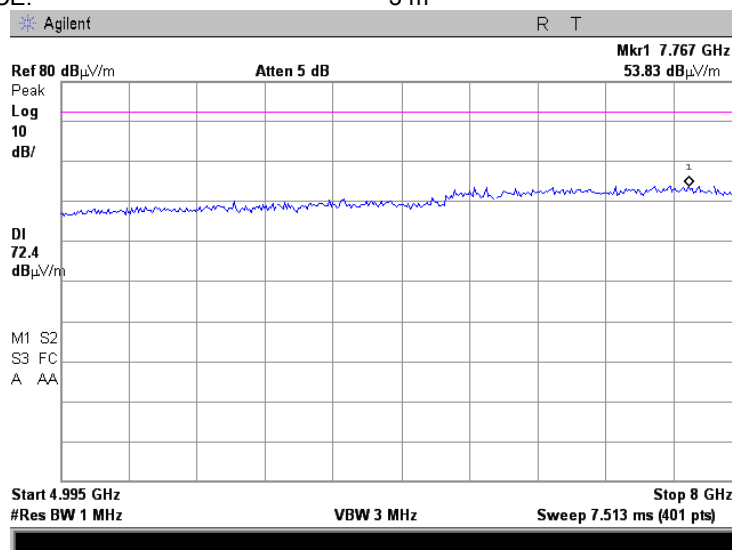



HERMON LABORATORIES

Test specification:	Section 90.210(l), 90.210(m), Radiated spurious emissions		
Test procedure:	47 CFR, Sections 2.1053, 90.210(m); TIA/EIA-603-C, Section 2.2.12		
Test mode:	Compliance	Verdict:	PASS
Date(s):	8/26/2012 - 8/30/2012		
Temperature: 24 °C	Air Pressure: 1006 hPa	Relative Humidity: 48 %	Power Supply: 48 VDC
Remarks:			

Plot 7.6.15 Radiated emission measurements in 8000 – 18000 MHz range

TEST SITE: Semi anechoic chamber
 CARRIER FREQUENCY: Low; mid; high
 ANTENNA POLARIZATION: Vertical and Horizontal
 TEST DISTANCE: 3 m

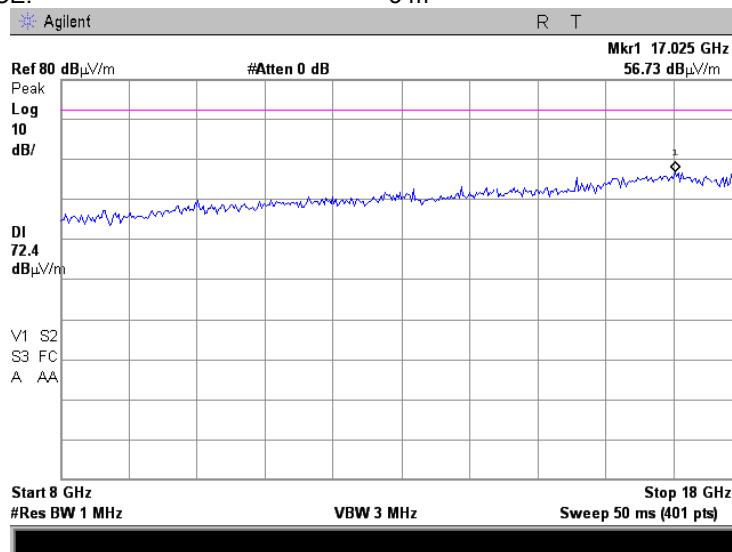

Plot 7.6.16 Radiated emission measurements in 18000 – 26500 MHz range

TEST SITE: Semi anechoic chamber
 CARRIER FREQUENCY: Low; mid; high
 ANTENNA POLARIZATION: Vertical and Horizontal
 TEST DISTANCE: 3 m

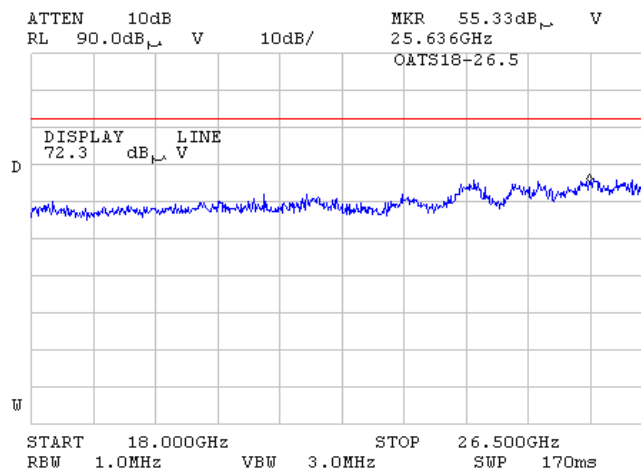



HERMON LABORATORIES

Test specification:	Section 90.210(l), 90.210(m), Radiated spurious emissions		
Test procedure:	47 CFR, Sections 2.1053, 90.210(m); TIA/EIA-603-C, Section 2.2.12		
Test mode:	Compliance	Verdict:	PASS
Date(s):	8/26/2012 - 8/30/2012		
Temperature: 24 °C	Air Pressure: 1006 hPa	Relative Humidity: 48 %	Power Supply: 48 VDC
Remarks:			

Plot 7.6.17 Radiated emission measurements in 26500-40000 MHz range

TEST SITE:	Semi anechoic chamber
CARRIER FREQUENCY:	Low; mid; high
ANTENNA POLARIZATION:	Vertical and Horizontal
TEST DISTANCE:	3 m

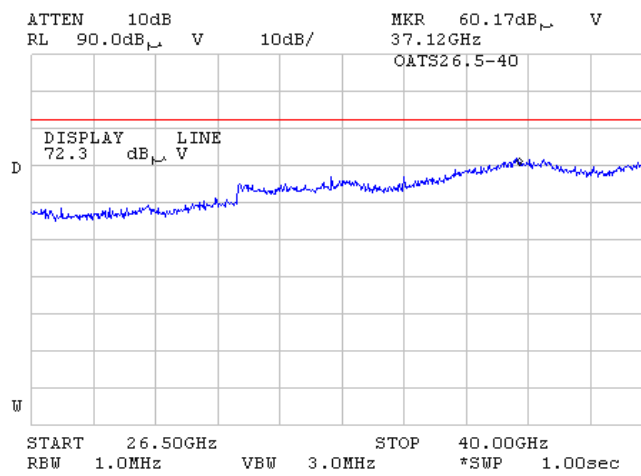



Test specification:		Section 90.213, Frequency stability	
Test procedure:		47 CFR, Section 2.1055; TIA/EIA-603-C Section 2.2.2	
Test mode:		Compliance	
Date(s):		9/02/2012	
Temperature: 24°C		Air Pressure: 1008 hPa	
Remarks:		Verdict: PASS	
		Relative Humidity: 51%	
		Power Supply: 48 VDC	

7.7 Frequency stability test

7.7.1 General

This test was performed to measure frequency stability of transmitter RF carrier. Specification test limits are given in Table 7.7.1.

Table 7.7.1 Frequency stability limits

Assigned frequency, MHz	Maximum allowed frequency displacement	
	ppm	Hz
4940.0 – 4990.0	The frequency stability shall be sufficient to ensure that the fundamental emissions stay within the authorized bands of operation	

7.7.2 Test procedure

- 7.7.2.1 The EUT was set up as shown in Figure 7.7.1, energized and its proper operation was checked.
- 7.7.2.2 The EUT power was turned off. Temperature within test chamber was set to +30°C and a period of time sufficient to stabilize all of the oscillator circuit components was allowed.
- 7.7.2.3 The EUT was powered on and carrier frequency was measured at start up moment and then every minute until frequency had been stabilized or 10 minutes elapsed whichever reached the last. The EUT was powered off.
- 7.7.2.4 The above procedure was repeated at 0°C and at the lowest test temperature.
- 7.7.2.5 The EUT was powered on and carrier frequency was measured at start up moment and at the end of stabilization period at the rest of test temperatures and voltages. The EUT was powered off.
- 7.7.2.6 Frequency displacement was calculated and compared with the limit as provided in Table 7.7.2.

Figure 7.7.1 Frequency stability test setup

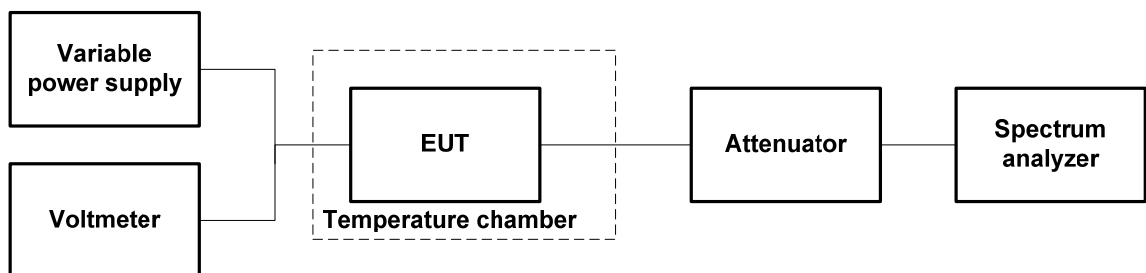



HERMON LABORATORIES

Test specification:		Section 90.213, Frequency stability	
Test procedure:		47 CFR, Section 2.1055; TIA/EIA-603-C Section 2.2.2	
Test mode:		Compliance	Verdict: PASS
Date(s):		9/02/2012	
Temperature: 24°C	Air Pressure: 1008 hPa	Relative Humidity: 51%	Power Supply: 48 VDC
Remarks:			

Table 7.7.2 Frequency stability test results

ASSIGNED FREQUENCY RANGE: 4940.0 – 4990.0 MHz
 NOMINAL POWER VOLTAGE: 48 VDC
 TEMPERATURE STABILIZATION PERIOD: 20 min
 POWER DURING TEMPERATURE TRANSITION: Off
 SPECTRUM ANALYZER MODE: Counter
 RESOLUTION BANDWIDTH: 1 kHz
 VIDEO BANDWIDTH: 1 kHz
 MODULATION: Unmodulated

T, °C	Voltage, VDC	Frequency, MHz							Max frequency drift, kHz		Max frequency drift, ppm	
		Start up	1st min	2nd min	3rd min	4th min	5th min	10th min	Positive	Negative	Positive	Negative
Low channel												
-30	nominal	4942.49746	4942.49757	4942.49762	4942.49761	4942.49761	4942.49760	4942.49745	0.54	NA	0.1092	NA
-20	nominal	4942.49795	4942.49795	4942.49798	4942.49797	4942.49795	4942.49791	4942.49764	0.9	NA	0.1820	NA
-10	nominal	4942.49912	4942.49914	4942.49912	4942.49909	4942.49907	4942.49902	4942.49889	2.06	NA	0.4107	NA
0	nominal	4942.49962	4942.49965	4942.49967	4942.49969	4942.49969	4942.49969	4942.49972	2.64	NA	0.5341	NA
10	nominal	4942.49807	4942.49819	4942.49827	4942.49833	4942.49838	4942.49840	4942.49862	1.54	NA	0.3115	NA
20	+15%	4942.49708	4942.49708	4942.49708	4942.49708	4942.49708	4942.49708	4942.49708	0	NA	0	NA
20	Nominal	4942.49717	4942.49717	4942.49708	4942.49708	4942.49708	4942.49708	4942.49708*	0.09	NA	0.0182	NA
20	-15%	4942.49708	4942.49717	4942.49708	4942.49708	4942.49708	4942.49708	4942.49708	0.09	NA	0.0182	NA
30	nominal	4942.49674	4942.49895	4942.49661	4942.49648	4942.49644	4942.49639	4942.49631	1.87	NA	0.3783	NA
40	nominal	4942.49679	4942.49651	4942.49647	4942.49639	4942.49636	4942.49630	4942.49620	N.A	-0.88	N.A	-0.1780
50	nominal	4942.49605	4942.49603	4942.49601	4942.49600	4942.49599	4942.49599	4942.49597	N.A	-1.11	N.A	-0.2245
Mid channel												
-30	nominal	4962.49727	4962.49750	4962.49750	4962.49751	4962.49750	4962.49747	4962.49738	0.26	NA	0.0523	NA
-20	nominal	4962.49760	4962.49782	4962.49782	4962.49782	4962.49784	4962.49783	4962.49774	0.59	NA	0.1188	NA
-10	nominal	4962.49891	4962.49892	4962.49894	4962.49892	4962.49893	4962.49893	4962.49891	1.69	NA	0.3405	NA
0	nominal	4962.49972	4962.49972	4962.49973	4962.49973	4962.49974	4962.49973	4962.49973	2.49	NA	0.5017	NA
10	nominal	4962.49882	4962.49874	4962.49971	4962.49872	4962.49872	4962.49874	4962.49878	1.57	NA	0.3163	NA
20	+15%	4962.49717	4962.49725	4962.49725	4962.49725	4962.49725	4962.49725	4962.49725	N.A	-0.08	N.A	-0.0161
20	nominal	4962.49742	4962.49725	4962.49725	4962.49725	4962.49725	4962.49725	4962.49725*	0.17	NA	0.0342	NA
20	-15%	4962.49725	4962.49708	4962.49708	4962.49708	4962.49709	4962.49708	4962.49708	0.17	NA	0.0342	NA
30	nominal	4962.49810	4962.49783	4962.49745	4962.49742	4962.49725	4962.49725	4962.49725	0.58	NA	0.1168	NA
40	nominal	4962.49925	4962.49925	4962.49725	4962.49712	4962.49708	4962.49708	4962.49700	2.0	NA	0.4030	NA
50	nominal	4962.49900	4962.49830	4962.49705	4962.49670	4962.49640	4962.49633	4962.49700	1.75	NA	0.3526	NA
High channel												
-30	nominal	4987.49736	4987.49740	4987.49740	4987.49741	4987.49742	4987.49742	4987.49739	0.34	NA	0.0681	NA
-20	nominal	4987.49769	4987.49773	4987.49775	4987.49776	4987.49774	4987.49775	4987.49772	0.68	NA	0.1363	NA
-10	nominal	4987.49893	4987.49899	4987.49898	4987.49895	4987.49895	4987.49892	4987.49870	1.91	NA	0.3829	NA
0	nominal	4987.49973	4987.49973	4987.49974	4987.49973	4987.49973	4987.49975	4987.49930	2.67	NA	0.5353	NA
10	nominal	4987.49909	4987.49905	4987.49903	4987.49900	4987.49897	4987.49894	4987.49892	2.01	NA	0.4030	NA
20	+15%	4987.49708	4987.49708	4987.49708	4987.49708	4987.49708	4987.49708	4987.49708	0	NA	0	NA
20	nominal	4987.49708	4987.49708	4987.49708	4987.49708	4987.49708	4987.49708	4987.49708*	0	NA	0	NA
20	-15%	4987.49708	4987.49708	4987.49708	4987.49708	4987.49708	4987.49708	4987.49708	0	NA	0	NA
30	nominal	4987.49812	4987.49797	4987.49775	4987.49758	4987.49733	4987.49722	4987.49686	1.04	NA	0.2085	NA
40	nominal	4987.49618	4987.49615	4987.49610	4987.49608	4987.49607	4987.49605	4987.49601	N.A	-1.07	N.A	-0.2145
50	nominal	4987.49589	4987.49591	4987.49593	4987.49593	4987.49592	4987.49592	4987.49590	N.A	-1.19	N.A	-0.2386

* - Reference frequency

Note: As no limit is specified by the standard for 4940.0 – 4990.0 MHz band the worst case test results are given for information purpose only.

Reference numbers of test equipment used

HL 1424	HL 3286	HL 3442	HL 3786	HL 4274		
---------	---------	---------	---------	---------	--	--

Full description is given in Appendix A.



8 APPENDIX A Test equipment and ancillaries used for tests

HL No	Description	Manufacturer	Model	Ser. No.	Last Cal./ Check	Due Cal./ Check
0446	Antenna, Loop, Active, 10 kHz - 30 MHz	EMCO	6502	2857	03-Jul-12	03-Jul-13
0521	EMI Receiver (Spectrum Analyzer) with RF filter section 9 kHz-6.5 GHz	Hewlett Packard	8546A	3617A 00319, 3448A002 53	29-Aug-11	29-Sep-12
0604	Antenna BiconiLog Log-Periodic/T Bow-TIE, 26 - 2000 MHz	EMCO	3141	9611-1011	20-May-12	20-May-14
0768	Antenna Standard Gain Horn, 18-26.5 GHz, WR-42, 25 dB gain	Quinstar Technology	QWH-4200-BA	110	03-Feb-12	03-Feb-15
0769	Antenna Standard Gain Horn, 26.5-40 GHz, WR28, 25 dB gain	Quinstar Technology	QWH-2800-BA	112	03-Feb-12	03-Feb-15
1424	Spectrum Analyzer, 30 Hz- 40 GHz	Agilent Technologies	8564EC	3946A002 19	25-Sep-11	25-Sep-12
3286	Temperature Chamber, (-50 to +170) °C	Thermotron	EL-8-CH-1-1-CO2	21-9048	11-Sep-11	11-Sep-12
3301	Power Meter, P-series, 50 MHz to 40 GHz	Agilent Technologies	N1911A	MY451010 57	14-Dec-11	14-Dec-12
3302	Power sensor, P-Series, 50 MHz to 40 GHz, -35/30 to 20 dBm	Agilent Technologies	N1922A	MY452405 86	14-Dec-11	14-Dec-12
3442	Precision Fixed Attenuator, 50 Ohm, 5 W, 20 dB, DC to 18 GHz	Mini-Circuits	BW-S20W5+	NA	07-Mar-12	07-Mar-13
3533	Amplifier, low noise, 6 to 18 GHz	Quinstar Technology	QLJ-06184040-J0	111590010 01	25-Dec-11	25-Dec-12
3535	Amplifier, low noise, 18 to 40 GHz	Quinstar Technology	QLJ-18404537-J0	111590030 01	10-Jul-12	10-Jul-13
3786	Precision Fixed Attenuator, 50 Ohm, 5 W, 10 dB, DC to 18 GHz	Mini-Circuits	BW-S10W5+	NA	19-Dec-11	19-Dec-12
3818	PSA Series Spectrum Analyzer, 3 Hz- 44 GHz	Agilent Technologies	E4446A	MY482502 88	16-Feb-12	16-Feb-13
3901	Microwave Cable Assembly, 40.0 GHz, 3.5 m, SMA/SMA	Huber-Suhner	SUCOFLEX 102A	1225/2A	08-Feb-12	08-Feb-13
3903	Microwave Cable Assembly, 40.0 GHz, 1.5 m, SMA/SMA	Huber-Suhner	SUCOFLEX 102A	1226/2A	08-Feb-12	08-Feb-13
4114	Antenna, Double-Ridged Waveguide Horn, 1-18 GHz	ETS Lindgren	3117	00123515	23-Jan-12	23-Jan-13
4274	Test Cable , DC-18 GHz, 1.8 m, SMA/M - N/M	Mini-Circuits	CBL-6FT-SMNM+	70047	23-Nov-11	23-Nov-12
4352	Low Loss Armored Test Cable, DC - 18 GHz, 6.2 m, N type-M/N type-M	MegaPhase	NC29-N1N1-244	12025101 002	06-Jun-12	06-Mar-13
4353	Low Loss Armored Test Cable, DC - 18 GHz, 6.2 m, N type-M/N type-M	MegaPhase	NC29-N1N1-244	12025101 003	06-Jun-12	06-Mar-13
4366	Directional coupler, 1 GHz to 18 GHz, 10 dB, SMA Female	Tiger Micro-Electronics Institute	TGD-A1101-10	01e-JSDE805-007	17-Apr-12	17-Apr-14



9 APPENDIX B Measurement uncertainties

Expanded uncertainty at 95% confidence in Hermon Labs EMC measurements

Test description	Expanded uncertainty
Transmitter tests	
Carrier power conducted at antenna connector	± 1.7 dB
Carrier power radiated (substitution method)	± 4.5 dB
Occupied bandwidth	±8%
Conducted emissions at RF antenna connector	9 kHz to 2.9 GHz: ± 2.6 dB 2.9 GHz to 6.46 GHz: ± 3.5 dB 6.46 GHz to 13.2 GHz: ± 4.3 dB 13.2 GHz to 22.0 GHz: ± 5.0 dB 22.0 GHz to 26.8 GHz: ± 5.5 dB 26.8 GHz to 40.0 GHz: ± 4.8 dB
Spurious emissions radiated 30 MHz – 40 GHz (substitution method)	± 4.5 dB
Frequency error	30 – 300 MHz: ± 50.5 Hz (1.68 ppm) 300 – 1000 MHz: ± 168 Hz (0.56 ppm)
Transient frequency behaviour	187 Hz ± 13.9 %
Duty cycle, timing (Tx ON / OFF) and average factor measurements	± 1.0 %
Unintentional radiator tests	
Conducted emissions with LISN	9 kHz to 150 kHz: ± 3.9 dB 150 kHz to 30 MHz: ± 3.8 dB
Radiated emissions at 3 m measuring distance Horizontal polarization	Biconilog antenna: ± 5.3 dB Biconical antenna: ± 5.0 dB Log periodic antenna: ± 5.3 dB Double ridged horn antenna: ± 5.3 dB
Vertical polarization	Biconilog antenna: ± 6.0 dB Biconical antenna: ± 5.7 dB Log periodic antenna: ± 6.0 dB Double ridged horn antenna: ± 6.0 dB

Hermon Laboratories is accredited by A2LA for calibration according to present requirements of ISO/IEC 17025 and NCSL Z540-1. The accreditation is granted to perform calibration of parameters that are listed in the Scope of Hermon Laboratories Accreditation.

Hermon Laboratories calibrates its reference and transfer standards by calibration laboratories accredited to ISO/IEC 17025 by a mutually recognized Accreditation Body or by a recognized national metrology institute. All reference and transfer standards used in the calibration system are traceable to national or international standards.

In-house calibration of all test and measurement equipment is performed on a regular basis according to Hermon Laboratories calibration procedures, manufacturer calibration/verification procedures or procedures defined in the relevant standards. The Hermon Laboratories test and measurement equipment is calibrated within the tolerances specified by the manufacturers and/or by the relevant standards.

10 APPENDIX C Test laboratory description

Tests were performed at Hermon Laboratories Ltd., which is a fully independent, private, EMC, safety, environmental and telecommunication testing facility.

Hermon Laboratories is listed by the Federal Communications Commission (USA) for all parts of Code of Federal Regulations 47 (CFR 47), Registration Numbers 90624 for OATS and 90623 for the anechoic chamber; by Industry Canada for electromagnetic emissions (file numbers IC 2186A-1 for OATS, IC 2186A-2 for anechoic chamber, IC 2186A-3 for full-anechoic chamber for RE measurements above 1 GHz), certified by VCCI, Japan (the registration numbers are R-808 for OATS, R-1082 for anechoic chamber, G-27 for full-anechoic chamber for RE measurements above 1 GHz, C-845 for conducted emissions site, T-1606 for conducted emissions at telecommunication ports), has a status of a Telefication - Listed Testing Laboratory, Certificate No. L138/00. The laboratory is accredited by American Association for Laboratory Accreditation (USA) according to ISO/IEC 17025 for electromagnetic compatibility, product safety, telecommunications testing and environmental simulation (for exact scope please refer to Certificate No. 839.01). The FCC Designation Number is US1003.

Address: P.O. Box 23, Binyamina 30500, Israel.
Telephone: +972 4628 8001
Fax: +972 4628 8277
e-mail: mail@hermonlabs.com
website: www.hermonlabs.com

Person for contact: Mr. Alex Usoskin, CEO.

11 APPENDIX D Specification references

FCC 47CFR part 90: 2011	Private land mobile radio services
ANSI C63.2: 1996	American National Standard for Instrumentation-Electromagnetic Noise and Field Strength, 10 kHz to 40 GHz-Specifications.
ANSI C63.4: 2003	American National Standard for Methods of Measurement of Radio-Noise Emissions from Low-Voltage Electrical and Electronic Equipment in the Range of 9 kHz to 40 GHz.
ANSI/TIA/EIA-603-C:2004	Land Mobile FM or PM Communications Equipment Measurement and Performance Standards



12 APPENDIX E Test equipment correction factors

Antenna factor
Active loop antenna
Model 6502, S/N 2857, HL 0446

Frequency, MHz	Magnetic antenna factor, dB	Electric antenna factor, dB
0.009	-32.8	18.7
0.010	-33.8	17.7
0.020	-38.3	13.2
0.050	-41.1	10.4
0.075	-41.3	10.2
0.100	-41.6	9.9
0.150	-41.7	9.8
0.250	-41.6	9.9
0.500	-41.8	9.8
0.750	-41.9	9.7
1.000	-41.4	10.1
2.000	-41.5	10.0
3.000	-41.4	10.2
4.000	-41.4	10.1
5.000	-41.5	10.1
10.000	-41.9	9.6
15.000	-41.9	9.6
20.000	-42.2	9.3
25.000	-42.8	8.7
30.000	-44.0	7.5

Antenna factor in dB(1/m) is to be added to receiver meter reading in dB(μ V) to convert it into field intensity in dB(μ V/m).

Antenna factor
Standard gain horn antenna
Quinstar Technology
Model QWH
Ser.No.110/112, HL 0768, HL 0769

Frequency min, GHz	Frequency max, GHz	Antenna factor, dB(1/m)
18.000	26.500	32.01
26.500	40.000	35.48
40.000	60.000	39.03
60.000	90.000	42.55
90.000	140.000	46.23
140.000	220.000	50.11

Antenna factor in dB(1/m) is to be added to receiver meter reading in dB(μ V) to convert it into field strength in dB(μ V/m).



Antenna factor
Biconilog antenna EMCO Model 3141
Ser.No.1011, HL 0604

Frequency, MHz	Antenna Factor, dB(1/m)	Frequency, MHz	Antenna Factor, dB(1/m)
26	7.8	940	24.0
28	7.8	960	24.1
30	7.8	980	24.5
40	7.2	1000	24.9
60	7.1	1020	25.0
70	8.5	1040	25.2
80	9.4	1060	25.4
90	9.8	1080	25.6
100	9.7	1100	25.7
110	9.3	1120	26.0
120	8.8	1140	26.4
130	8.7	1160	27.0
140	9.2	1180	27.0
150	9.8	1200	26.7
160	10.2	1220	26.5
170	10.4	1240	26.5
180	10.4	1260	26.5
190	10.3	1280	26.6
200	10.6	1300	27.0
220	11.6	1320	27.8
240	12.4	1340	28.3
260	12.8	1360	28.2
280	13.7	1380	27.9
300	14.7	1400	27.9
320	15.2	1420	27.9
340	15.4	1440	27.8
360	16.1	1460	27.8
380	16.4	1480	28.0
400	16.6	1500	28.5
420	16.7	1520	28.9
440	17.0	1540	29.6
460	17.7	1560	29.8
480	18.1	1580	29.6
500	18.5	1600	29.5
520	19.1	1620	29.3
540	19.5	1640	29.2
560	19.8	1660	29.4
580	20.6	1680	29.6
600	21.3	1700	29.8
620	21.5	1720	30.3
640	21.2	1740	30.8
660	21.4	1760	31.1
680	21.9	1780	31.0
700	22.2	1800	30.9
720	22.2	1820	30.7
740	22.1	1840	30.6
760	22.3	1860	30.6
780	22.6	1880	30.6
800	22.7	1900	30.6
820	22.9	1920	30.7
840	23.1	1940	30.9
860	23.4	1960	31.2
880	23.8	1980	31.6
900	24.1	2000	32.0
920	24.1		

Antenna factor in dB(1/m) is to be added to receiver meter reading in dB(μ V) to convert it into field intensity in dB(μ V/m).



Antenna factor
Double-ridged waveguide horn antenna
ETS Lindgren, Model 3117, serial number: 00123515, HL 4114

Frequency, MHz	Antenna factor, dB/m		
	Measured	Manufacturer	Deviation
1000	28.0	28.4	-0.4
1500	28.0	27.4	0.6
2000	31.2	30.9	0.3
2500	32.5	33.4	-0.9
3000	32.9	32.6	0.3
3500	32.7	32.8	-0.1
4000	33.1	33.4	-0.3
4500	33.8	33.9	-0.1
5000	33.8	34.1	-0.3
5500	34.4	34.5	-0.1
6000	35.0	35.2	-0.2
6500	35.4	35.5	-0.1
7000	35.7	35.7	0.0
7500	35.9	35.7	0.2
8000	35.8	35.8	0.0
8500	35.9	35.8	0.1
9000	36.3	36.2	0.1
9500	36.6	36.6	0.0
10000	37.1	37.1	0.0
10500	37.6	37.5	0.1
11000	37.9	37.7	0.2
11500	38.5	38.1	0.4
12000	39.2	38.7	0.5
12500	39.0	38.9	0.1
13000	39.1	39.1	0.0
13500	38.9	38.8	0.1
14000	39.0	38.8	0.2
14500	39.6	39.9	-0.3
15000	39.9	39.7	0.2
15500	39.9	40.1	-0.2
16000	40.7	40.8	-0.1
16500	41.3	41.8	-0.5
17000	42.5	42.1	0.4
17500	41.3	41.2	0.1
18000	41.4	40.9	0.5

Antenna factor is to be added to receiver meter reading in dB(μ V) to convert to field strength in dB(μ V/meter)



Cable loss
Microwave Cable Assembly, Huber-Suhner, 40 GHz, 3.5 m, SMA-SMA, S/N 1225/2A
HL 3901

Frequency, MHz	Cable loss, dB	Frequency, MHz	Cable loss, dB	Frequency, MHz	Cable loss, dB
10	0.09	9500	4.29	21000	6.67
100	0.41	10000	4.40	22000	6.92
500	0.93	10500	4.52	23000	7.00
1000	1.33	11000	4.64	24000	7.18
1500	1.63	11500	4.76	25000	7.29
2000	1.90	12000	4.87	26000	7.55
2500	2.12	12500	4.99	27000	7.70
3000	2.33	13000	5.11	28000	7.88
3500	2.50	13500	5.20	29000	8.02
4000	2.67	14000	5.31	30000	8.15
4500	2.82	14500	5.42	31000	8.35
5000	2.99	15000	5.51	32000	8.40
5500	3.16	15500	5.58	33000	8.62
6000	3.32	16000	5.68	34000	8.73
6500	3.51	16500	5.78	35000	8.78
7000	3.65	17000	5.91	36000	8.94
7500	3.79	17500	5.99	37000	9.21
8000	3.92	18000	6.07	38000	9.37
8500	4.04	19000	6.36	39000	9.45
9000	4.18	20000	6.49	40000	9.52



Cable loss
Microwave Cable Assembly, Huber-Suhner, 40 GHz, 1.5 m, SMA-SMA, S/N 1226/2A
HL 3903

Frequency, MHz	Cable loss, dB	Frequency, MHz	Cable loss, dB	Frequency, MHz	Cable loss, dB
10	-0.02	9500	1.84	21000	2.98
100	0.15	10000	1.86	22000	3.07
500	0.38	10500	1.93	23000	3.13
1000	0.56	11000	1.99	24000	3.21
1500	0.69	11500	2.04	25000	3.26
2000	0.82	12000	2.10	26000	3.48
2500	0.90	12500	2.15	27000	3.44
3000	0.98	13000	2.21	28000	3.53
3500	1.06	13500	2.25	29000	3.59
4000	1.11	14000	2.29	30000	3.66
4500	1.17	14500	2.34	31000	3.70
5000	1.24	15000	2.36	32000	3.79
5500	1.32	15500	2.40	33000	3.88
6000	1.40	16000	2.45	34000	3.94
6500	1.50	16500	2.48	35000	3.91
7000	1.56	17000	2.56	36000	4.05
7500	1.62	17500	2.58	37000	4.22
8000	1.68	18000	2.60	38000	4.25
8500	1.74	19000	2.84	39000	4.27
9000	1.78	20000	2.88	40000	4.33



Cable loss
Test cable, Mini-Circuits, S/N 70047, 18 GHz, 1.8 m, SMA/M - N/M
CBL-6FT-SMNM+, HL 4274

Frequency, MHz	Cable loss, dB	Frequency, MHz	Cable loss, dB	Frequency, MHz	Cable loss, dB	Frequency, MHz	Cable loss, dB
10	0.07	4800	1.69	9800	2.62	14800	3.42
30	0.11	4900	1.70	9900	2.63	14900	3.39
50	0.14	5000	1.72	10000	2.64	15000	3.38
100	0.21	5100	1.75	10100	2.64	15100	3.40
200	0.26	5200	1.76	10200	2.66	15200	3.41
300	0.30	5300	1.77	10300	2.67	15300	3.40
400	0.37	5400	1.79	10400	2.68	15400	3.39
500	0.44	5500	1.82	10500	2.68	15500	3.41
600	0.49	5600	1.85	10600	2.70	15600	3.44
700	0.54	5700	1.86	10700	2.71	15700	3.46
800	0.58	5800	1.87	10800	2.73	15800	3.45
900	0.63	5900	1.91	10900	2.74	15900	3.47
1000	0.67	6000	1.94	11000	2.76	16000	3.51
1100	0.71	6100	1.97	11100	2.77	16100	3.56
1200	0.75	6200	1.98	11200	2.78	16200	3.55
1300	0.78	6300	1.99	11300	2.79	16300	3.54
1400	0.81	6400	2.02	11400	2.80	16400	3.57
1500	0.85	6500	2.05	11500	2.82	16500	3.62
1600	0.88	6600	2.06	11600	2.83	16600	3.61
1700	0.91	6700	2.06	11700	2.84	16700	3.60
1800	0.94	6800	2.08	11800	2.85	16800	3.62
1900	0.97	6900	2.10	11900	2.87	16900	3.68
2000	1.00	7000	2.12	12000	2.88	17000	3.70
2100	1.03	7100	2.12	12100	2.89	17100	3.68
2200	1.06	7200	2.13	12200	2.90	17200	3.70
2300	1.08	7300	2.16	12300	2.92	17300	3.80
2400	1.11	7400	2.19	12400	2.94	17400	3.84
2500	1.14	7500	2.22	12500	2.95	17500	3.83
2600	1.16	7600	2.23	12600	2.96	17600	3.83
2700	1.19	7700	2.26	12700	2.98	17700	3.86
2800	1.21	7800	2.30	12800	3.00	17800	3.86
2900	1.27	7900	2.33	12900	3.02	17900	3.80
3000	1.29	8000	2.35	13000	3.03	18000	3.79
3100	1.32	8100	2.37	13100	3.06		
3200	1.35	8200	2.41	13200	3.08		
3300	1.37	8300	2.44	13300	3.09		
3400	1.38	8400	2.47	13400	3.10		
3500	1.41	8500	2.48	13500	3.13		
3600	1.43	8600	2.51	13600	3.17		
3700	1.46	8700	2.53	13700	3.17		
3800	1.47	8800	2.55	13800	3.18		
3900	1.49	8900	2.56	13900	3.22		
4000	1.52	9000	2.57	14000	3.26		
4100	1.55	9100	2.58	14100	3.28		
4200	1.56	9200	2.59	14200	3.30		
4300	1.58	9300	2.59	14300	3.35		
4400	1.60	9400	2.60	14400	3.39		
4500	1.63	9500	2.60	14500	3.39		
4600	1.65	9600	2.61	14600	3.39		
4700	1.67	9700	2.61	14700	3.41		



Cable loss
Low Loss Armored Test Cable, MegaPhase, 18 GHz, 6.2 m, N type-M/N type-M,
NC29-N1N1-244S/N 12025101 002,
HL 4352

Frequency, MHz	Cable loss, dB	Frequency, MHz	Cable loss, dB
50	0.20	9000	2.81
100	0.28	9500	2.89
300	0.49	10000	3.00
500	0.63	10500	3.07
1000	0.90	11000	3.15
1500	1.10	11500	3.23
2000	1.28	12000	3.30
2500	1.44	12500	3.38
3000	1.57	13000	3.47
3500	1.71	13500	3.55
4000	1.85	14000	3.61
4500	1.95	14500	3.68
5000	2.05	15000	3.76
5500	2.14	15500	3.86
6000	2.27	16000	3.92
6500	2.38	16500	3.97
7000	2.47	17000	4.03
7500	2.58	17500	4.10
8000	2.65	18000	4.18
8500	2.74		



Cable loss
Low Loss Armored Test Cable, MegaPhase, 18 GHz, 6.2 m, N type-M/N type-M,
NC29-N1N1-244S/N 12025101 003,
HL 4353

Frequency, MHz	Cable loss, dB	Frequency, MHz	Cable loss, dB
50	0.20	9000	2.71
100	0.27	9500	2.81
300	0.47	10000	2.90
500	0.61	10500	2.97
1000	0.87	11000	3.06
1500	1.07	11500	3.13
2000	1.24	12000	3.20
2500	1.39	12500	3.26
3000	1.53	13000	3.34
3500	1.65	13500	3.39
4000	1.77	14000	3.47
4500	1.89	14500	3.54
5000	1.99	15000	3.62
5500	2.07	15500	3.69
6000	2.20	16000	3.76
6500	2.30	16500	3.83
7000	2.39	17000	3.86
7500	2.51	17500	3.94
8000	2.58	18000	4.02
8500	2.65		



13 APPENDIX F Abbreviations and acronyms

A	ampere
AC	alternating current
A/m	ampere per meter
AM	amplitude modulation
AVRG	average (detector)
cm	centimeter
dB	decibel
dBm	decibel referred to one milliwatt
dB(μ V)	decibel referred to one microvolt
dB(μ V/m)	decibel referred to one microvolt per meter
dB(μ A)	decibel referred to one microampere
DC	direct current
EIRP	equivalent isotropically radiated power
ERP	effective radiated power
EUT	equipment under test
F	frequency
GHz	gigahertz
GND	ground
H	height
HL	Hermon laboratories
Hz	hertz
k	kilo
kHz	kilohertz
LO	local oscillator
m	meter
MHz	megahertz
min	minute
mm	millimeter
ms	millisecond
μ s	microsecond
NA	not applicable
NB	narrow band
OATS	open area test site
Ω	Ohm
PM	pulse modulation
PS	power supply
ppm	part per million (10^{-6})
QP	quasi-peak
RE	radiated emission
RF	radio frequency
rms	root mean square
Rx	receive
s	second
T	temperature
Tx	transmit
V	volt
WB	wideband

END OF DOCUMENT