

Test report

311425-1TRFWL

Date of issue: May 1, 2017

Applicant:

Siemens Canada Ltd.

Product:

Multiprotocol Intelligent Node with LTE and Wi-Fi

Model:

RX1400

FCC ID:

VG5RX1400

IC Registration number:

4997A-VG5RX1400

Specifications:

◆ **FCC 47 CFR Part 15 Subpart E, §15.407**

Unlicensed National Information Infrastructure Devices

◆ **RSS-247, Issue 1, Section 6, May 2015**

Digital Transmission Systems (DTSs), Frequency Hopping Systems (FHSs) and Licence-Exempt Local Area Network (LE-LAN) Devices

Test location

Company name	Nemko Canada Inc.
Address	303 River Road
City	Ottawa
Province	Ontario
Postal code	K1V 1H2
Country	Canada
Telephone	+1 613 737 9680
Facsimile	+1 613 737 9691
Toll free	+1 800 563 6336
Website	www.nemko.com
Site number	FCC: 176392; IC: 2040A-4 (3 m semi anechoic chamber)

Tested by	Andrey Adelberg, Senior Wireless/EMC Specialist
Reviewed by	Kevin Rose, Wireless/EMC Specialist
Review date	May 1, 2017
Reviewer signature	

Limits of responsibility

Note that the results contained in this report relate only to the items tested and were obtained in the period between the date of initial receipt of samples and the date of issue of the report.

This test report has been completed in accordance with the requirements of ISO/IEC 17025. All results contain in this report are within Nemko Canada's ISO/IEC 17025 accreditation.

Copyright notification

Nemko Canada Inc. authorizes the applicant to reproduce this report provided it is reproduced in its entirety and for use by the company's employees only. Any use which a third party makes of this report, or any reliance on or decisions to be made based on it, are the responsibility of such third parties.

Nemko Canada Inc. accepts no responsibility for damages, if any, suffered by any third party as a result of decisions made or actions based on this report.

© Nemko Canada Inc.

Table of contents

Table of contents	3
Section 1. Report summary	4
1.1 Applicant and manufacturer	4
1.2 Test specifications	4
1.3 Test methods.....	4
1.4 Statement of compliance	4
1.5 Exclusions.....	4
1.6 Test report revision history	4
Section 2. Summary of test results	5
2.1 FCC Part 15 Subpart C, general requirements test results.....	5
2.2 FCC Part 15 Subpart E, test results	5
2.3 IC RSS-GEN, Issue 4, test results	5
2.4 IC RSS-247, Issue 1, test results	6
Section 3. Equipment under test (EUT) details	7
3.1 Sample information.....	7
3.2 EUT information	7
3.3 Technical information	7
3.4 Product description and theory of operation	9
3.5 EUT exercise details.....	9
3.6 EUT setup diagram	10
Section 4. Engineering considerations	11
4.1 Modifications incorporated in the EUT.....	11
4.2 Technical judgment.....	11
4.3 Deviations from laboratory tests procedures.....	11
Section 5. Test conditions	12
5.1 Atmospheric conditions	12
5.2 Power supply range.....	12
Section 6. Measurement uncertainty	13
6.1 Uncertainty of measurement	13
Section 7. Test equipment	14
7.1 Test equipment list.....	14
Section 8. Testing data	15
8.1 FCC 15.403(i) Emission bandwidth	15
8.2 RSS-Gen 6.6 Occupied bandwidth	18
8.3 FCC 15.407(e) and RSS-247 6.2.4(1) Minimum 6 dB bandwidth.....	21
8.4 FCC 15.407(a)(1) and RSS-247 6.2.2(1) 5.15–5.25 GHz band output power and spectral density limits.....	23
8.5 FCC 15.407(a)(2) and RSS-247 6.2.2(1) 5.25–5.35 GHz band output power and spectral density limits.....	30
8.6 FCC 15.407(a)(2) and RSS-247 6.2.3(1) 5.47–5.725 GHz band output power and spectral density limits.....	37
8.7 FCC 15.407(a)(3) and RSS-247 6.2.4(1) 5.725–5.850 GHz band output power and spectral density limits.....	45
8.8 FCC 15.407(b) and RSS-247 6.2 Undesirable (unwanted) emissions.....	52
8.9 FCC 15.207(a) and RSS-Gen 8.8 AC power line conducted emissions limits	110
8.10 FCC 15.407(g) and RSS-Gen 8.11 Frequency stability	120
Section 9. Block diagrams of test set-ups	122
9.1 Radiated emissions set-up for frequencies below 1 GHz.....	122
9.2 Radiated emissions set-up for frequencies above 1 GHz.....	123
9.3 Conducted emissions set-up	123

Section 1. Report summary

1.1 Applicant and manufacturer

Company name	Siemens Canada Ltd.
Address	300 Applewood Cres
City	Concord
Province/State	Ontario
Postal/Zip code	L4K 5C7
Country	Canada

1.2 Test specifications

FCC 47 CFR Part 15, Subpart E, Clause 15.407	Unlicensed National Information Infrastructure Devices
RSS-247, Issue 1, May 2015	Digital Transmission Systems (DTSS), Frequency Hopping Systems (FHSs) and Licence-Exempt Local Area Network (LE-LAN) Devices

1.3 Test methods

789033 D02 General UNII Test Procedures New Rules v01r03 (August 22, 2016)	Guidelines for Compliance Testing of Unlicensed National Information Infrastructure (U-NII) Devices Part 15, Subpart E
ANSI C63.10 v2013	American National Standard of Procedures for Compliance Testing of Unlicensed Wireless Devices

1.4 Statement of compliance

In the configuration tested, the EUT was found compliant.

Testing was completed against all relevant requirements of the test standard. Results obtained indicate that the product under test complies in full with the requirements tested. The test results relate only to the items tested.

See "Summary of test results" for full details.

1.5 Exclusions

None

1.6 Test report revision history

Revision #	Details of changes made to test report
TRF	Original report issued

Section 2. Summary of test results

2.1 FCC Part 15 Subpart C, general requirements test results

Part	Test description	Verdict
§15.31(e)	Variation of power source	Pass ¹
§15.203	Antenna requirement	Pass ²

Notes: ¹Measurements of the variation of the input power or the radiated signal level of the fundamental frequency component of the emission, as appropriate, was performed with the supply voltage varied between 85 % and 115 % of the nominal rated supply voltage. No noticeable output power variation was observed

² EUT has a unique antenna connector and it is professionally installed.

2.2 FCC Part 15 Subpart E, test results

Part	Test description	Verdict
§15.403(i)	Emission bandwidth	Not applicable
§15.407(a)(1)	Power and density limits within 5.15–5.25 GHz band	Pass
§15.407(a)(2)	Power and density limits within 5.25–5.35 GHz and 5.47–5.725 GHz bands	Pass
§15.407(a)(3)	Power and density limits within 5.725–5.85 GHz band	Pass
§15.407(b)(1)	Undesirable emission limits for 5.15–5.25 GHz band	Pass
§15.407(b)(2)	Undesirable emission limits for 5.25–5.35 GHz band	Pass
§15.407(b)(3)	Undesirable emission limits for 5.47–5.725 GHz bands	Pass
§15.407(b)(4)	Undesirable emission limits for 5.725–5.85 GHz band	Pass
§15.407(b)(6)	Conducted limits for U-NII devices using an AC power line	Pass
§15.407(e)	Minimum 6 dB bandwidth of U-NII devices within the 5.725-5.85 GHz band	Pass
§15.407(g)	Frequency stability	Pass
§15.407(h)(1) ¹	Transmit power control (TPC)	Pass
§15.407(h)(2) ¹	Dynamic Frequency Selection (DFS)	Not tested

Note: ¹DFS is covered in separate report.

2.3 IC RSS-GEN, Issue 4, test results

Part	Test description	Verdict
7.1.2 ¹	Receiver radiated emission limits	Not applicable
7.1.3 ¹	Receiver conducted emission limits	Not applicable
8.8	Power Line Conducted Emissions Limits for Licence-Exempt Radio Apparatus	Pass

Notes: ¹According to sections 5.2 and 5.3 of RSS-Gen, Issue 4: if EUT does not have a stand-alone receiver neither scanner receiver, then it exempt from receiver requirements.

2.4 IC RSS-247, Issue 1, test results

Section	Test description	Verdict
6.1 (1) ¹	Types of Modulation	Pass
6.2.1 (1)	Power limits for 5150–5250 MHz band	Pass
6.2.2 (1)	Power limits for 5250–5350 MHz band	Pass
6.2.3 (1)	Power limits for 5470–5600 MHz and 5650–5725 MHz bands	Pass
6.2.4 (1)	Power limits for 5725–5850 MHz band	Pass
6.2.4 (1)	Minimum 6 dB bandwidth	Pass
6.2.1 (2)	Unwanted emission limits for 5150–5250 MHz band	Pass
6.2.2 (2)	Unwanted emission limits for 5250–5350 MHz band	Pass
6.2.2 (2)	TPC requirements for devices with a maximum e.i.r.p. greater than 500 mW	Pass
6.2.2 (3)	e.i.r.p. at different elevations restrictions for 5250–5350 MHz band	Not applicable
6.2.3 (2)	Unwanted emission limits for 5470–5600 MHz and 5650–5725 MHz bands	Pass
6.2.4 (2)	Unwanted emission limits for 5725–5850 MHz band	Pass
6.3	DFS for devices operating in the bands 5250–5350 MHz, 5470–5600 MHz and 5650–5725 MHz	Not tested ²

Notes: ¹ The EUT employs digital modulations, such as: 802.11a, 802.11n HT20 and 802.11n HT40.

²DFS is covered in separate report.

Section 3. Equipment under test (EUT) details

3.1 Sample information

Receipt date	August 1, 2016
Nemko sample ID number	1 (48 V _{DC}), 2 (24 V _{DC}) and 3 (120 V _{AC})

3.2 EUT information

Product name	Multiprotocol Intelligent Node with LTE and Wi-Fi
Model	RX1400
Part number	6GK60140AM220AA0-ZA02+C00+D00+E00+F00+G02+V00 (48 V _{DC})
Part number variants	6GK60140AM210AA0-ZA02+C00+D00+E00+F00+G02+V00 (24 V _{DC}) 6GK60140AM230AA0-ZA02+C00+D00+E00+F00+G02+V00 (120 V _{AC})
Serial number	RUM/H805061787 (48 V _{DC}), RUM/H805061785 (24 V _{DC}), RUM/H805061788 (120 V _{AC})

3.3 Technical information

Applicant IC company number	4997A
IC UPN number	VG5RX1400
All used IC test site(s) Reg. number	2040A-4
RSS number and Issue number	RSS-247 Issue 1, Section 6, May 2015
Frequency bands	(U-NII-1) 5150–5250 MHz, (U-NII-2A) 5250–5350 MHz, (U-NII-2C) 5470–5600 MHz, 5650–5725 MHz and (U-NII-3) 5725–5850 MHz
Frequency Min (MHz)	(U-NII-1 for 20 MHz channels): 5180, (U-NII-2A for 20 MHz channels): 5260, (U-NII-2C for 20 MHz channels): 5500, (U-NII-3 for 20 MHz channels): 5745 (U-NII-1 for 40 MHz channels): 5190, (U-NII-2A for 40 MHz channels): 5270, (U-NII-2C for 40 MHz channels): 5510, (U-NII-3 for 40 MHz channels): 5755
Frequency Max (MHz)	(U-NII-1 for 20 MHz channels): 5240, (U-NII-2A for 20 MHz channels): 5320, (U-NII-2C for 20 MHz channels): 5700, (U-NII-3 for 20 MHz channels): 5825 (U-NII-1 for 40 MHz channels): 5230, (U-NII-2A for 40 MHz channels): 5310, (U-NII-2C for 40 MHz channels): 5670, (U-NII-3 for 40 MHz channels): 5795
RF power Min (W), Conducted	(U-NII-2A for 20 MHz channels): 0.0013, (U-NII-2C for 20 MHz channels): 0.0014 (U-NII-2A for 40 MHz channels): 0.0025, (U-NII-2C for 40 MHz channels): 0.0025
RF power Max (W), Conducted	(U-NII-1 for 20 MHz channels): 0.0265, (U-NII-2A for 20 MHz channels): 0.0139, (U-NII-2C for 20 MHz channels): 0.0187, (U-NII-3 for 20 MHz channels): 0.0279 (U-NII-1 for 40 MHz channels): 0.0134, (U-NII-2A for 40 MHz channels): 0.0069, (U-NII-2C for 40 MHz channels): 0.0090, (U-NII-3 for 40 MHz channels): 0.0162
Field strength, Units @ distance	N/A
Measured BW (kHz)	(26 dB BW 802.11a) 25160, (26 dB BW 802.11n HT20) 25780, (26 dB BW 802.11n HT40) 46150 (6 dB BW 802.11a) 15064, (6 dB BW 802.11n HT20) 15224, (6 dB BW 802.11n HT40) 33940
Calculated BW (kHz), as per TRC-43	N/A
Type of modulation	802.11a, 802.11n HT20 and 802.11n HT40
Emission classification (F1D, G1D, D1D)	W7D
Power requirements	120 V _{AC} or 24 V _{DC} PS or 48 V _{DC} PS

Table 3.3-1: Antenna¹ information

Model number	Directivity	Gain, dBi
ANT793-8DJ (FCC only)	Directional	18 ²
ANT793-8DP (FCC only)	Directional	13.5 ³
ANT795-6DC (FCC only)	Directional	9
ANT793-6DG (FCC only)	Directional	9
ANT795-6MN (FCC only)	Omni-directional	8 ⁴
ANT793-6DT (FCC only)	Omni-directional	8 ⁴
ANT795-6MT (FCC only)	Omni-directional	7 ⁵
ANT793-4MN	Omni-directional	6
ANT795-4MA	Omni-directional	5
ANT795-4MC	Omni-directional	5
ANT795-4MD	Omni-directional	5
ANT793-6MN	Omni-directional	5
ANT795-4MX	Omni-directional	2.5

Notes: ¹The EUT is professionally installed

²Connected via 10 m cable, 6X1875-5CN10, 8.8 dB loss. Total gain 9.2 dBi

³Connected via 5 m cable, 6X1875-5CH50, 4.4 dB loss. Total gain 9.1 dBi

⁴Connected via 5 m cable, 6X1875-5CH50, 4.4 dB loss. Total gain 3.6 dBi

⁵Connected via 5 m cable, 6X1875-5CH50, 4.4 dB loss. Total gain 2.6 dBi

3.4 Product description and theory of operation

The RUGGEDCOM RX1400 is a multi-protocol intelligent node that combines Ethernet switch, routing and firewall functionality with various wide area connectivity options. The RX1400 switch, with its rugged metal housing, is designed for DIN rail, panel or rack mounting. The device has IP40 degree protection, does not use internal fans for cooling and supports a -40 to 85 °C (-40 to 185 °F) extended temperature range.

Wireless Interfaces

WWAN module (Contains FCC ID: N7NMC7355 / IC: 2417C-MC7355):

- LTE: 700- B13, B17, 800/900/1800/2100/2600 MHz
- UMTS/HSPA+: 850/900/1900/2100 MHz
- Quad-Band EDGE/GPRS/GSM

GNSS

WLAN Access Point and Client: WLAN Direct® (multi-channel, multi-role) dual band transceiver support of IEEE 802.11a/b/g/n for 2.4 GHz 2x2 MIMO and 5 GHz SISO, 20 MHz and 40 MHz channels

Ethernet Interfaces

- 4 × 10/100Base-T RJ45 ports Serial Interfaces with Isolation

Optical SFP Pluggable Transceivers

- 2 × 1000 Mbit/s ports

Serial Interface with isolation

- 2 × RS232/422/485 ports

Other Interfaces

- Isolated built-in power input
- RS232 console port for local management/ diagnostics on the device
- SMA connectors for RF interfaces

Power Supply

- 12 to 24 V_{DC}
- ±12 to 24 V_{DC}
- ±48 V_{DC}
- HI VAC/VDC

3.5 EUT exercise details

EUT was controlled from laptop using web GUI and CLI commands.

3.6 EUT setup diagram

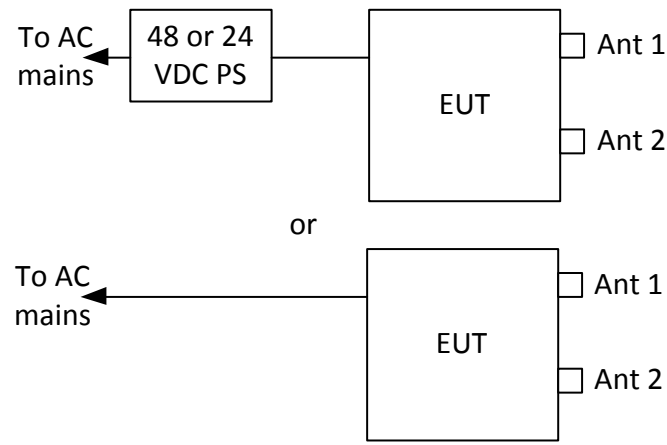

Figure 3.6-1: Setup diagram

Note: 48 V_{DC} power supply: Artesyn ADNB008-48-1PM-C, SN: U65107088

24 V_{DC} power supply: XPpower DNR60US24, SN: 131245-9601041401253

Section 4. Engineering considerations

4.1 Modifications incorporated in the EUT

There were no modifications performed to the EUT during this assessment.

4.2 Technical judgment

None

4.3 Deviations from laboratory tests procedures

No deviations were made from laboratory procedures.

Section 5. Test conditions

5.1 Atmospheric conditions

Temperature	15–30 °C
Relative humidity	20–75 %
Air pressure	860–1060 mbar

When it is impracticable to carry out tests under these conditions, a note to this effect stating the ambient temperature and relative humidity during the tests shall be recorded and stated.

5.2 Power supply range

The normal test voltage for equipment to be connected to the mains shall be the nominal mains voltage. For the purpose of the present document, the nominal voltage shall be the declared voltage, or any of the declared voltages $\pm 5\%$, for which the equipment was designed.

Section 6. Measurement uncertainty

6.1 Uncertainty of measurement

Measurement uncertainty budgets for the tests are detailed below. Measurement uncertainty calculations assume a coverage factor of $K = 2$ with 95% certainty.

Test name	Measurement uncertainty, dB
All antenna port measurements	0.55
Conducted spurious emissions	1.13
Radiated spurious emissions	3.78
AC power line conducted emissions	3.55

Section 7. Test equipment

7.1 Test equipment list

Table 7.1-1: Equipment list

Equipment	Manufacturer	Model no.	Asset no.	Cal cycle	Next cal.
3 m EMI test chamber	TDK	SAC-3	FA002047	1 year	Dec. 01/17
Flush mount turntable	Sunol	FM2022	FA002082	—	NCR
Controller	Sunol	SC104V	FA002060	—	NCR
Antenna mast	Sunol	TLT2	FA002061	—	NCR
AC Power source	Chenwa	2700M-10k	FA002716	—	VOU
Receiver/spectrum analyzer	Rohde & Schwarz	ESU 26	FA002043	1 year	Jan. 07/17
Spectrum analyzer	Rohde & Schwarz	FSU	FA001877	1 year	Apr. 15/17
Bilog antenna (20–3000 MHz)	Sunol	JB3	FA002108	1 year	Apr. 28/17
Horn antenna (1–18 GHz)	EMCO	3115	FA000825	1 year	Apr. 26/17
Horn antenna 18–40 GHz	EMCO	3116	FA001847	1 year	Apr.15/17
Pre-amplifier (1–18 GHz)	JCA	JCA118-503	FA002091	1 year	April 26/17
Pre-amplifier (18–26 GHz)	Narda	BBS-1826N612	FA001550	—	VOU
Pre-amplifier (26–40 GHz)	Narda	DBL-2640N610	FA001556	—	VOU
LISN	Rohde & Schwarz	ENV216	FA002023	1 year	Mar. 08/17
Temperature chamber	Espec	EPX-4H	FA002735	1 year	Jan 26/17

Note: NCR - no calibration required, VOU - verify on use

Section 8. Testing data

8.1 FCC 15.403(i) Emission bandwidth

8.1.1 Definitions and limits

For purposes of this subpart the emission bandwidth shall be determined by measuring the width of the signal between two points, one below the carrier center frequency and one above the carrier center frequency, that are 26 dB down relative to the maximum level of the modulated carrier. Determination of the emissions bandwidth is based on the use of measurement instrumentation employing a peak detector function with an instrument resolution bandwidth approximately equal to 1.0 percent of the emission bandwidth of the device under measurement.

8.1.2 Test summary

Test date	December 5, 2016	Temperature	24 °C
Test engineer	Andrey Adelberg	Air pressure	1010 mbar
Verdict	Pass	Relative humidity	34 %

8.1.3 Observations, settings and special notes

Spectrum analyser settings:

Resolution bandwidth	300 kHz for 20 MHz channels and 1 MHz for 40 MHz channels
Video bandwidth	> RBW
Detector mode	Peak
Trace mode	Max Hold

8.1.4 Test data

Table 8.1-1: 26 dB bandwidth results for U-NII-1 band

Modulation	Channel	26 dB bandwidth at ch0, MHz	26 dB bandwidth at ch1, MHz
802.11a	36	24.84	23.64
	44	23.79	23.71
	48	23.24	23.64
802.11n HT20	36	25.72	24.43
	44	24.84	23.96
	48	25.32	24.52
802.11n HT40	38	46.15	44.62
	46	45.26	43.85

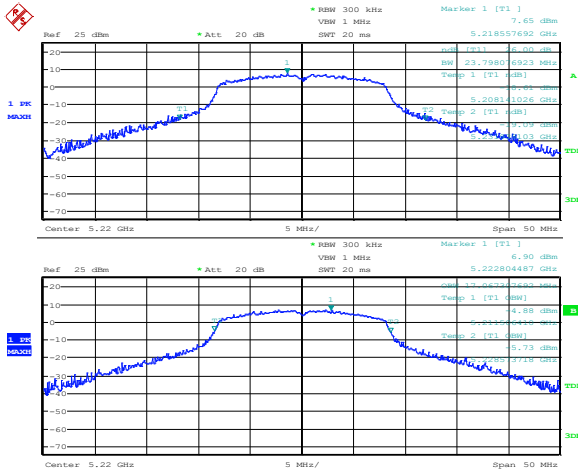

Table 8.1-2: 26 dB bandwidth results for U-NII-2a band

Modulation	Channel	26 dB bandwidth at ch0, MHz	26 dB bandwidth at ch1, MHz
802.11a	52	23.88	23.48
	60	23.56	23.48
	64	24.28	23.64
802.11n HT20	52	24.52	24.76
	60	24.12	24.76
	64	24.04	24.68
802.11n HT40	54	45.77	46.15
	62	45.64	45.64

Table 8.1-3: 26 dB bandwidth results for U-NII-2c band

Modulation	Channel	26 dB bandwidth at ch0, MHz	26 dB bandwidth at ch1, MHz
802.11a	100	23.72	23.80
	116	25.16	24.60
	140	23.96	23.32
802.11n HT20	100	24.68	24.84
	116	26.44	25.72
	140	24.60	24.92
802.11n HT40	102	45.64	45.13
	110	45.51	45.90
	134	45.51	45.38



Date: 5.DEC.2016 16:05:47

Figure 8.1-1: 26 dB bandwidth on 802.11a, sample plot

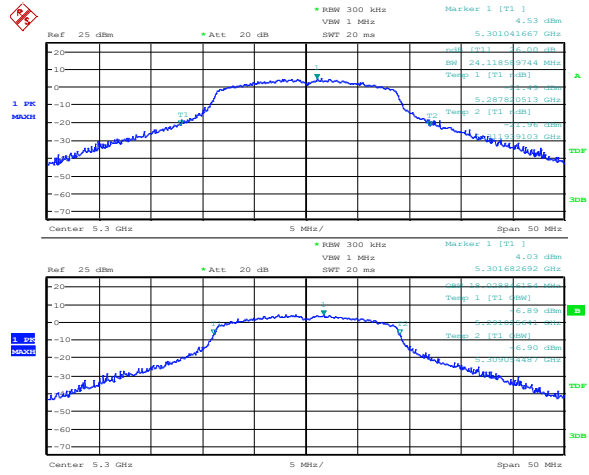

Date: 5.DEC.2016 16:15:37

Figure 8.1-2: 26 dB bandwidth on 802.11n HT20, sample plot

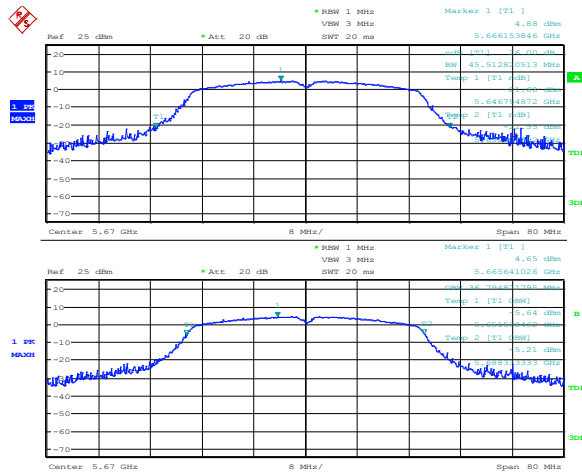

Date: 5.DEC.2016 15:55:53

Figure 8.1-3: 26 dB bandwidth on 802.11n HT40, sample plot

8.2 RSS-Gen 6.6 Occupied bandwidth

8.2.1 Definitions and limits

The emission bandwidth (×dB) is defined as the frequency range between two points, one above and one below the carrier frequency, at which the spectral density of the emission is attenuated × dB below the maximum in-band spectral density of the modulated signal. Spectral density (power per unit bandwidth) is to be measured with a detector of resolution bandwidth in the range of 1% to 5% of the anticipated emission bandwidth, and a video bandwidth at least 3× the resolution bandwidth.

When the occupied bandwidth limit is not stated in the applicable RSS or reference measurement method, the transmitted signal bandwidth shall be reported as the 99% emission bandwidth, as calculated or measured.

8.2.2 Test summary

Test date	December 5, 2016	Temperature	24 °C
Test engineer	Andrey Adelberg	Air pressure	1010 mbar
Verdict	Pass	Relative humidity	34 %

8.2.3 Observations, settings and special notes

Spectrum analyser settings:

Resolution bandwidth:	300 kHz for 20 MHz channels. 1 MHz for 40 MHz channels
Video bandwidth:	≥3 × RBW
Detector mode:	Peak
Trace mode:	Max Hold

8.2.4 Test data

Table 8.2-1: 99 % bandwidth results for U-NII-1 band

Modulation	Channel	99 % occupied bandwidth for ch0, MHz	99 % occupied bandwidth for ch1, MHz
802.11a	36	17.07	16.91
	44	17.07	16.91
	48	17.07	16.99
802.11n HT20	36	18.11	18.11
	44	18.19	18.04
	48	18.18	18.11
802.11n HT40	38	36.93	36.67
	46	36.79	36.67



Table 8.2-2: 99 % bandwidth results for U-NII-2a band

Modulation	Channel	99 % occupied bandwidth for ch0, MHz	99 % occupied bandwidth for ch1, MHz
802.11a	52	16.91	16.91
	60	16.99	16.99
	64	16.99	16.99
802.11n HT20	52	18.04	18.11
	60	18.04	18.11
	64	18.04	18.11
802.11n HT40	54	36.67	36.93
	62	36.79	36.79

Table 8.2-3: 99 % bandwidth results for U-NII-2c band

Modulation	Channel	99 % occupied bandwidth for ch0, MHz	99 % occupied bandwidth for ch1, MHz
802.11a	100	16.99	17.07
	116	17.31	16.99
	140	16.91	16.91
802.11n HT20	100	18.04	18.19
	116	18.35	18.37
	140	18.11	18.18
802.11n HT40	102	36.54	36.79
	110	36.79	36.79
	134	36.79	36.79

Section 8
Test name
Specification

Testing data
 RSS-Gen Clause 6.6 Occupied bandwidth
 RSS-Gen, Issue 4

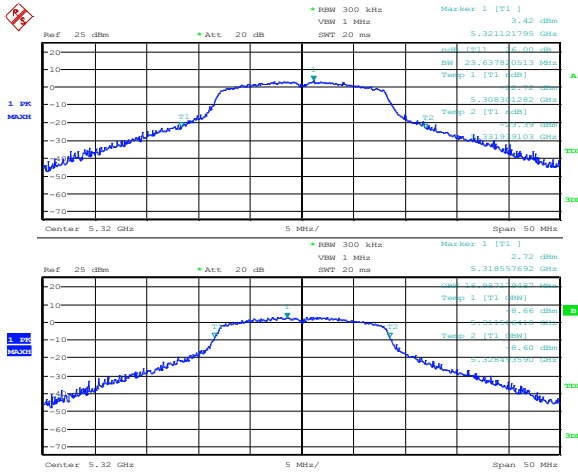

Date: 6.DEC.2016 15:13:09

Figure 8.2-1: 99 % bandwidth on 802.11a, sample plot

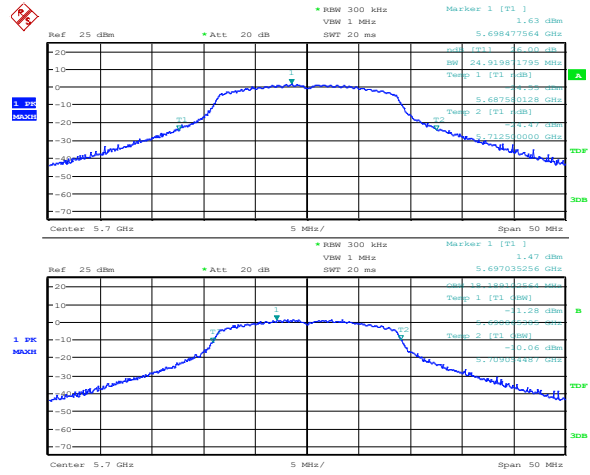

Date: 5.DEC.2016 16:30:10

Figure 8.2-2: 99 % bandwidth on 802.11n HT20, sample plot

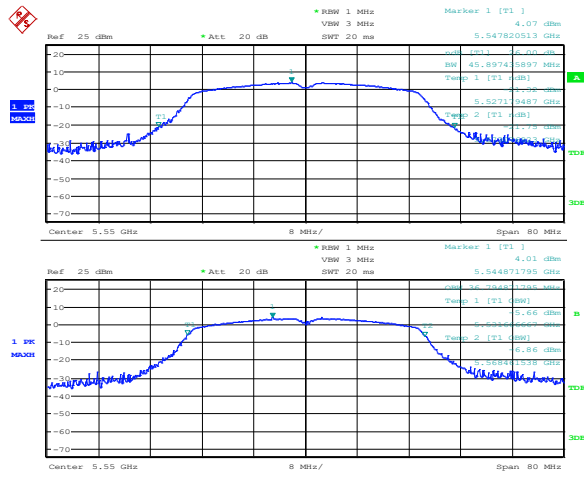

Date: 5.DEC.2016 15:43:52

Figure 8.2-3: 99 % bandwidth on 802.11n HT40, sample plot

8.3 FCC 15.407(e) and RSS-247 6.2.4(1) Minimum 6 dB bandwidth

8.3.1 Definitions and limits

For equipment operating in the band 5725–5850 MHz, the minimum 6 dB bandwidth shall be at least 500 kHz.

8.3.2 Test summary

Test date	December 16, 2016	Temperature	22 °C
Test engineer	Andrey Adelberg	Air pressure	1007 mbar
Verdict	Pass	Relative humidity	39 %

8.3.3 Observations, settings and special notes

Spectrum analyser settings:

Resolution bandwidth	100 kHz
Video bandwidth	> RBW
Detector mode	Peak
Trace mode	Max Hold

8.3.4 Test data

Table 8.3-1: 6 dB bandwidth results

Modulation	6 dB bandwidth at ch0, MHz	6 dB bandwidth at ch1, MHz	Minimum requirement, MHz
802.11a	13.862	15.064	0.500
802.11n HT20	15.016	15.224	0.500
802.11n HT40	33.766	33.974	0.500

Section 8
Test name
Specification

Testing data
 FCC 15.407(e) and RSS-247 6.2.4(1) Minimum 6 dB bandwidth
 FCC 15 Subpart E and RSS-247 Issue 1

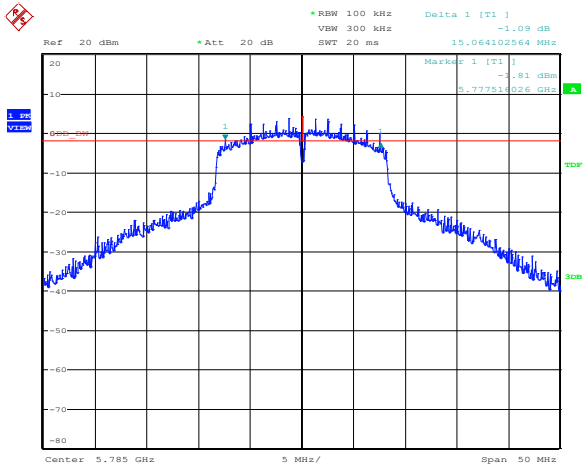

Date: 16.DEC.2016 12:10:37

Figure 8.3-1: 6 dB bandwidth on 802.11a, sample plot

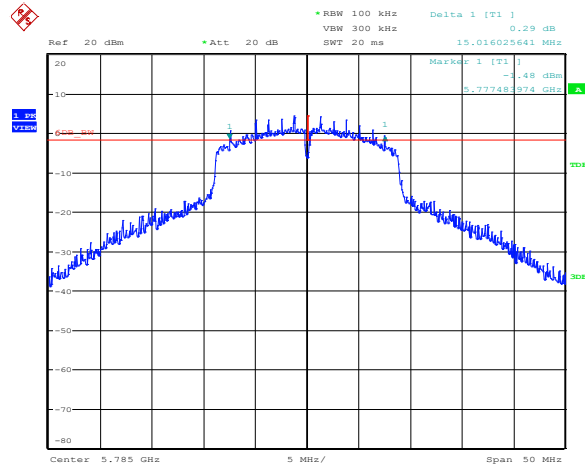

Date: 16.DEC.2016 11:29:09

Figure 8.3-2: 6 dB bandwidth on 802.11n HT20, sample plot

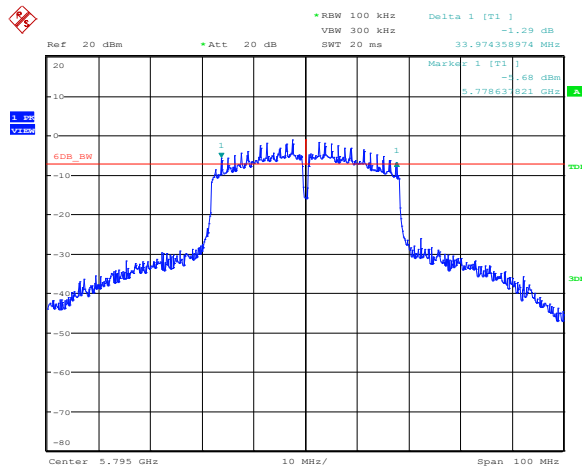

Date: 16.DEC.2016 12:13:05

Figure 8.3-3: 6 dB bandwidth on 802.11n HT40, sample plot

8.4 FCC 15.407(a)(1) and RSS-247 6.2.2(1) 5.15–5.25 GHz band output power and spectral density limits

8.4.1 Definitions and limits

FCC:

(i) For an outdoor access point operating in the band 5.15–5.25 GHz, the maximum conducted output power over the frequency band of operation shall not exceed 1 W (30 dBm) provided the maximum antenna gain does not exceed 6 dBi. In addition, the maximum power spectral density shall not exceed 17 dBm in any 1 megahertz band. If transmitting antennas of directional gain greater than 6 dBi are used, both the maximum conducted output power and the maximum power spectral density shall be reduced by the amount in dB that the directional gain of the antenna exceeds 6 dBi. The maximum e.i.r.p. at any elevation angle above 30 degrees as measured from the horizon must not exceed 125 mW (21 dBm).

(ii) For an indoor access point operating in the band 5.15–5.25 GHz, the maximum conducted output power over the frequency band of operation shall not exceed 1 W (30 dBm) provided the maximum antenna gain does not exceed 6 dBi. In addition, the maximum power spectral density shall not exceed 17 dBm in any 1 megahertz band. If transmitting antennas of directional gain greater than 6 dBi are used, both the maximum conducted output power and the maximum power spectral density shall be reduced by the amount in dB that the directional gain of the antenna exceeds 6 dBi.

(iii) For fixed point-to-point access points operating in the band 5.15–5.25 GHz, the maximum conducted output power over the frequency band of operation shall not exceed 1 W (30 dBm). In addition, the maximum power spectral density shall not exceed 17 dBm in any 1 megahertz band. Fixed point-to-point U-NII devices may employ antennas with directional gain up to 23 dBi without any corresponding reduction in the maximum conducted output power or maximum power spectral density. For fixed point-to-point transmitters that employ a directional antenna gain greater than 23 dBi, a 1 dB reduction in maximum conducted output power and maximum power spectral density is required for each 1 dB of antenna gain in excess of 23 dBi. Fixed, point-to-point operations exclude the use of point-to-multipoint systems, omnidirectional applications, and multiple collocated transmitters transmitting the same information. The operator of the U-NII device, or if the equipment is professionally installed, the installer, is responsible for ensuring that systems employing high gain directional antennas are used exclusively for fixed, point-to-point operations.

(iv) For client devices in the 5.15–5.25 GHz band, the maximum conducted output power over the frequency band of operation shall not exceed 250 mW (24 dBm) provided the maximum antenna gain does not exceed 6 dBi. In addition, the maximum power spectral density shall not exceed 11 dBm in any 1 megahertz band. If transmitting antennas of directional gain greater than 6 dBi are used, both the maximum conducted output power and the maximum power spectral density shall be reduced by the amount in dB that the directional gain of the antenna exceeds 6 dBi.

ISED:

The maximum e.i.r.p. shall not exceed 200 mW (23 dBm) or $10 + 10 \log_{10} B$, dBm, whichever power is less. B is the 99% emission bandwidth in megahertz. The e.i.r.p. spectral density shall not exceed 10 dBm in any 1.0 MHz band.

8.4.2 Test summary

Test date	December 5, 2016	Temperature	24 °C
Test engineer	Andrey Adelberg	Air pressure	1010 mbar
Verdict	Pass	Relative humidity	34 %

8.4.3 Observations, settings and special notes

In all tables below Output power margin was calculated as the difference between the power limit and highest conducted output power between two antenna ports.

In all tables below EIRP and EIRPSD were calculated as the sum of the antenna gain and highest conducted output power between two antenna ports.



8.4.4 Test data

Table 8.4-1: Output power measurements results as per FCC for 18 dBi (9.2 dBi with cable loss) antenna gain.

Modulation	Channel	Frequency, MHz	Conducted output power at ch0, dBm	Conducted output power at ch1, dBm	Power limit, dBm	Margin, dB	Antenna gain, dBi	EIRP, dBm	EIRP limit, dBm	Margin, dB
802.11a	36	5180	13.95	13.38	26.80	12.85	9.20	23.15	36.00	12.85
	44	5220	14.03	13.43	26.80	12.77	9.20	23.23	36.00	12.77
	48	5240	14.20	13.57	26.80	12.60	9.20	23.40	36.00	12.60
802.11n HT20	36	5180	14.12	12.99	26.80	12.68	9.20	23.32	36.00	12.68
	44	5220	14.21	13.53	26.80	12.59	9.20	23.41	36.00	12.59
	48	5240	14.24	13.68	26.80	12.56	9.20	23.44	36.00	12.56
802.11n HT40	38	5190	10.59	10.13	26.80	16.21	9.20	19.79	36.00	16.21
	46	5230	11.28	10.77	26.80	15.52	9.20	20.48	36.00	15.52

Table 8.4-2: Output power measurements results as per FCC for 13.5 dBi (9.1 dBi with cable loss) antenna gain.

Modulation	Channel	Frequency, MHz	Conducted output power at ch0, dBm	Conducted output power at ch1, dBm	Power limit, dBm	Margin, dB	Antenna gain, dBi	EIRP, dBm	EIRP limit, dBm	Margin, dB
802.11a	36	5180	13.95	13.38	26.90	12.95	9.10	23.05	36.00	12.95
	44	5220	14.03	13.43	26.90	12.87	9.10	23.13	36.00	12.87
	48	5240	14.20	13.57	26.90	12.70	9.10	23.30	36.00	12.70
802.11n HT20	36	5180	14.12	12.99	26.90	12.78	9.10	23.22	36.00	12.78
	44	5220	14.21	13.53	26.90	12.69	9.10	23.31	36.00	12.69
	48	5240	14.24	13.68	26.90	12.66	9.10	23.34	36.00	12.66
802.11n HT40	38	5190	10.59	10.13	26.90	16.31	9.10	19.69	36.00	16.31
	46	5230	11.28	10.77	26.90	15.62	9.10	20.38	36.00	15.62

Table 8.4-3: Output power measurements results as per FCC for 9 dBi antenna gain.

Modulation	Channel	Frequency, MHz	Conducted output power at ch0, dBm	Conducted output power at ch1, dBm	Power limit, dBm	Margin, dB	Antenna gain, dBi	EIRP, dBm	EIRP limit, dBm	Margin, dB
802.11a	36	5180	13.95	13.38	27.00	13.05	9.00	22.95	36.00	13.05
	44	5220	14.03	13.43	27.00	12.97	9.00	23.03	36.00	12.97
	48	5240	14.20	13.57	27.00	12.80	9.00	23.20	36.00	12.80
802.11n HT20	36	5180	14.12	12.99	27.00	12.88	9.00	23.12	36.00	12.88
	44	5220	14.21	13.53	27.00	12.79	9.00	23.21	36.00	12.79
	48	5240	14.24	13.68	27.00	12.76	9.00	23.24	36.00	12.76
802.11n HT40	38	5190	10.59	10.13	27.00	16.41	9.00	19.59	36.00	16.41
	46	5230	11.28	10.77	27.00	15.72	9.00	20.28	36.00	15.72

Section 8

Testing data

Test name

FCC 15.407(a)(1) and RSS-247 6.2.2(1) 5.15–5.25 GHz band output power and spectral density limits

Specification

FCC Part 15 Subpart E and RSS-247, Issue 1



Table 8.4-4: Output power measurements results as per FCC for 8 dBi (3.6 dBi with cable loss) antenna gain.

Modulation	Channel	Frequency, MHz	Conducted output power at ch0, dBm	Conducted output power at ch1, dBm	Power limit, dBm	Margin, dB	Antenna gain, dBi	EIRP, dBm	EIRP limit, dBm	Margin, dB
802.11a	36	5180	13.95	13.38	30.00	16.05	3.60	17.55	36.00	18.45
	44	5220	14.03	13.43	30.00	15.97	3.60	17.63	36.00	18.37
	48	5240	14.20	13.57	30.00	15.80	3.60	17.80	36.00	18.20
802.11n HT20	36	5180	14.12	12.99	30.00	15.88	3.60	17.72	36.00	18.28
	44	5220	14.21	13.53	30.00	15.79	3.60	17.81	36.00	18.19
	48	5240	14.24	13.68	30.00	15.76	3.60	17.84	36.00	18.16
802.11n HT40	38	5190	10.59	10.13	30.00	19.41	3.60	14.19	36.00	21.81
	46	5230	11.28	10.77	30.00	18.72	3.60	14.88	36.00	21.12

Table 8.4-5: Output power measurements results as per FCC for 7 dBi (2.6 dBi with cable loss) antenna gain.

Modulation	Channel	Frequency, MHz	Conducted output power at ch0, dBm	Conducted output power at ch1, dBm	Power limit, dBm	Margin, dB	Antenna gain, dBi	EIRP, dBm	EIRP limit, dBm	Margin, dB
802.11a	36	5180	13.95	13.38	30.00	16.05	2.60	16.55	36.00	19.45
	44	5220	14.03	13.43	30.00	15.97	2.60	16.63	36.00	19.37
	48	5240	14.20	13.57	30.00	15.80	2.60	16.80	36.00	19.20
802.11n HT20	36	5180	14.12	12.99	30.00	15.88	2.60	16.72	36.00	19.28
	44	5220	14.21	13.53	30.00	15.79	2.60	16.81	36.00	19.19
	48	5240	14.24	13.68	30.00	15.76	2.60	16.84	36.00	19.16
802.11n HT40	38	5190	10.59	10.13	30.00	19.41	2.60	13.19	36.00	22.81
	46	5230	11.28	10.77	30.00	18.72	2.60	13.88	36.00	22.12

Table 8.4-6: Output power measurements results as per FCC for 6 dBi antenna gain.

Modulation	Channel	Frequency, MHz	Conducted output power at ch0, dBm	Conducted output power at ch1, dBm	Power limit, dBm	Margin, dB	Antenna gain, dBi	EIRP, dBm	EIRP limit, dBm	Margin, dB
802.11a	36	5180	13.95	13.38	30.00	16.05	6.00	19.95	36.00	16.05
	44	5220	14.03	13.43	30.00	15.97	6.00	20.03	36.00	15.97
	48	5240	14.20	13.57	30.00	15.80	6.00	20.20	36.00	15.80
802.11n HT20	36	5180	14.12	12.99	30.00	15.88	6.00	20.12	36.00	15.88
	44	5220	14.21	13.53	30.00	15.79	6.00	20.21	36.00	15.79
	48	5240	14.24	13.68	30.00	15.76	6.00	20.24	36.00	15.76
802.11n HT40	38	5190	10.59	10.13	30.00	19.41	6.00	16.59	36.00	19.41
	46	5230	11.28	10.77	30.00	18.72	6.00	17.28	36.00	18.72

Table 8.4-7: Output power measurements results as per FCC for 5 dBi antenna gain.

Modulation	Channel	Frequency, MHz	Conducted output power at ch0, dBm	Conducted output power at ch1, dBm	Power limit, dBm	Margin, dB	Antenna gain, dBi	EIRP, dBm	EIRP limit, dBm	Margin, dB
802.11a	36	5180	13.95	13.38	30.00	16.05	5.00	18.95	36.00	17.05
	44	5220	14.03	13.43	30.00	15.97	5.00	19.03	36.00	16.97
	48	5240	14.20	13.57	30.00	15.80	5.00	19.20	36.00	16.80
802.11n HT20	36	5180	14.12	12.99	30.00	15.88	5.00	19.12	36.00	16.88
	44	5220	14.21	13.53	30.00	15.79	5.00	19.21	36.00	16.79
	48	5240	14.24	13.68	30.00	15.76	5.00	19.24	36.00	16.76
802.11n HT40	38	5190	10.59	10.13	30.00	19.41	5.00	15.59	36.00	20.41
	46	5230	11.28	10.77	30.00	18.72	5.00	16.28	36.00	19.72

Section 8

Testing data

Test name

FCC 15.407(a)(1) and RSS-247 6.2.2(1) 5.15–5.25 GHz band output power and spectral density limits

Specification

FCC Part 15 Subpart E and RSS-247, Issue 1



Table 8.4-8: Output power measurements results as per FCC for 2.5 dBi antenna gain.

Modulation	Channel	Frequency, MHz	Conducted output power at ch0, dBm	Conducted output power at ch1, dBm	Power limit, dBm	Margin, dB	Antenna gain, dBi	EIRP, dBm	EIRP limit, dBm	Margin, dB
802.11a	36	5180	13.95	13.38	30.00	16.05	2.50	16.45	36.00	19.55
	44	5220	14.03	13.43	30.00	15.97	2.50	16.53	36.00	19.47
	48	5240	14.20	13.57	30.00	15.80	2.50	16.70	36.00	19.30
802.11n HT20	36	5180	14.12	12.99	30.00	15.88	2.50	16.62	36.00	19.38
	44	5220	14.21	13.53	30.00	15.79	2.50	16.71	36.00	19.29
	48	5240	14.24	13.68	30.00	15.76	2.50	16.74	36.00	19.26
802.11n HT40	38	5190	10.59	10.13	30.00	19.41	2.50	13.09	36.00	22.91
	46	5230	11.28	10.77	30.00	18.72	2.50	13.78	36.00	22.22

Table 8.4-9: PSD measurements results as per FCC for 18 dBi (9.2 dBi with cable loss) antenna gain.

Modulation	Channel	Frequency, MHz	Conducted PSD at ch0, dBm/MHz	Conducted PSD at ch1, dBm/MHz	PSD limit, dBm/MHz	Margin, dB
802.11a	36	5180	3.84	3.31	13.80	9.96
	44	5220	3.95	3.32	13.80	9.85
	48	5240	4.05	3.46	13.80	9.75
802.11n HT20	36	5180	3.87	2.78	13.80	9.93
	44	5220	3.97	3.29	13.80	9.83
	48	5240	3.97	3.43	13.80	9.83
802.11n HT40	38	5190	-2.31	-2.66	13.80	16.11
	46	5230	-1.92	-2.38	13.80	15.72

Table 8.4-10: PSD measurements results as per FCC for 13.5 dBi (9.1 dBi with cable loss) antenna gain.

Modulation	Channel	Frequency, MHz	Conducted PSD at ch0, dBm/MHz	Conducted PSD at ch1, dBm/MHz	PSD limit, dBm/MHz	Margin, dB
802.11a	36	5180	3.84	3.31	13.90	10.06
	44	5220	3.95	3.32	13.90	9.95
	48	5240	4.05	3.46	13.90	9.85
802.11n HT20	36	5180	3.87	2.78	13.90	10.03
	44	5220	3.97	3.29	13.90	9.93
	48	5240	3.97	3.43	13.90	9.93
802.11n HT40	38	5190	-2.31	-2.66	13.90	16.21
	46	5230	-1.92	-2.38	13.90	15.82

Table 8.4-11: PSD measurements results as per FCC for 9 dBi antenna gain.

Modulation	Channel	Frequency, MHz	Conducted PSD at ch0, dBm/MHz	Conducted PSD at ch1, dBm/MHz	PSD limit, dBm/MHz	Margin, dB
802.11a	36	5180	3.84	3.31	14.00	10.16
	44	5220	3.95	3.32	14.00	10.05
	48	5240	4.05	3.46	14.00	9.95
802.11n HT20	36	5180	3.87	2.78	14.00	10.13
	44	5220	3.97	3.29	14.00	10.03
	48	5240	3.97	3.43	14.00	10.03
802.11n HT40	38	5190	-2.31	-2.66	14.00	16.31
	46	5230	-1.92	-2.38	14.00	15.92

Section 8

Testing data

Test name

FCC 15.407(a)(1) and RSS-247 6.2.2(1) 5.15–5.25 GHz band output power and spectral density limits

Specification

FCC Part 15 Subpart E and RSS-247, Issue 1



Table 8.4-12: PSD measurements results as per FCC for 6 dBi, 5 dBi, 2.5 dBi, 8 dBi (3.6 dBi with cable loss), and 7 dBi (2.6 dBi with cable loss) antenna gains.

Modulation	Channel	Frequency, MHz	Conducted PSD at ch0, dBm/MHz	Conducted PSD at ch1, dBm/MHz	PSD limit, dBm/MHz	Margin, dB
802.11a	36	5180	3.84	3.31	17.00	13.16
	44	5220	3.95	3.32	17.00	13.05
	48	5240	4.05	3.46	17.00	12.95
802.11n HT20	36	5180	3.87	2.78	17.00	13.13
	44	5220	3.97	3.29	17.00	13.03
	48	5240	3.97	3.43	17.00	13.03
802.11n HT40	38	5190	-2.31	-2.66	17.00	19.31
	46	5230	-1.92	-2.38	17.00	18.92

Table 8.4-13: Output power measurements results as per ISSED for 6 dBi antenna gain.

Modulation	Channel	Frequency, MHz	Conducted output power at ch0, dBm	Conducted output power at ch1, dBm	Antenna gain, dBi	EIRP, dBm	EIRP limit, dBm	Margin, dB
802.11a	36	5180	13.95	13.38	6.00	19.95	22.28	2.33
	44	5220	14.03	13.43	6.00	20.03	22.28	2.25
	48	5240	14.20	13.57	6.00	20.20	22.28	2.08
802.11n HT20	36	5180	14.12	12.99	6.00	20.12	22.56	2.44
	44	5220	14.21	13.53	6.00	20.21	22.56	2.35
	48	5240	14.24	13.68	6.00	20.24	22.56	2.32
802.11n HT40	38	5190	10.59	10.13	6.00	16.59	23.00	6.41
	46	5230	11.28	10.77	6.00	17.28	23.00	5.72

Table 8.4-14: Output power measurements results as per ISSED for 5 dBi antenna gain.

Modulation	Channel	Frequency, MHz	Conducted output power at ch0, dBm	Conducted output power at ch1, dBm	Antenna gain, dBi	EIRP, dBm	EIRP limit, dBm	Margin, dB
802.11a	36	5180	13.95	13.38	5.00	18.95	22.28	3.33
	44	5220	14.03	13.43	5.00	19.03	22.28	3.25
	48	5240	14.20	13.57	5.00	19.20	22.28	3.08
802.11n HT20	36	5180	14.12	12.99	5.00	19.12	22.56	3.44
	44	5220	14.21	13.53	5.00	19.21	22.56	3.35
	48	5240	14.24	13.68	5.00	19.24	22.56	3.32
802.11n HT40	38	5190	10.59	10.13	5.00	15.59	23.00	7.41
	46	5230	11.28	10.77	5.00	16.28	23.00	6.72

Table 8.4-15: Output power measurements results as per ISSED for 2.5 dBi antenna gain.

Modulation	Channel	Frequency, MHz	Conducted output power at ch0, dBm	Conducted output power at ch1, dBm	Antenna gain, dBi	EIRP, dBm	EIRP limit, dBm	Margin, dB
802.11a	36	5180	13.95	13.38	2.50	16.45	22.28	5.83
	44	5220	14.03	13.43	2.50	16.53	22.28	5.75
	48	5240	14.20	13.57	2.50	16.70	22.28	5.58
802.11n HT20	36	5180	14.12	12.99	2.50	16.62	22.56	5.94
	44	5220	14.21	13.53	2.50	16.71	22.56	5.85
	48	5240	14.24	13.68	2.50	16.74	22.56	5.82
802.11n HT40	38	5190	10.59	10.13	2.50	13.09	23.00	9.91
	46	5230	11.28	10.77	2.50	13.78	23.00	9.22

Section 8

Testing data

Test name

FCC 15.407(a)(1) and RSS-247 6.2.2(1) 5.15–5.25 GHz band output power and spectral density limits

Specification

FCC Part 15 Subpart E and RSS-247, Issue 1



Table 8.4-16: PSD measurements results as per ISED for 6 dBi antenna gain.

Modulation	Channel	Frequency, MHz	Conducted PSD at ch0, dBm/MHz	Conducted PSD at ch1, dBm/MHz	Antenna gain, dBi	EIRPSD, dBm/MHz	EIRPSD limit, dBm/MHz	Margin, dB
802.11a	36	5180	1.68	1.24	6.00	7.68	10.00	2.32
	44	5220	1.75	1.20	6.00	7.75	10.00	2.25
	48	5240	1.97	1.76	6.00	7.97	10.00	2.03
802.11n HT20	36	5180	0.55	0.10	6.00	6.55	10.00	3.45
	44	5220	1.05	0.36	6.00	7.05	10.00	2.95
	48	5240	0.71	0.30	6.00	6.71	10.00	3.29
802.11n HT40	38	5190	-4.99	-5.43	6.00	1.01	10.00	8.99
	46	5230	-1.92	-2.38	6.00	4.08	10.00	5.92

Table 8.4-17: PSD measurements results as per ISED for 5 dBi antenna gain.

Modulation	Channel	Frequency, MHz	Conducted PSD at ch0, dBm/MHz	Conducted PSD at ch1, dBm/MHz	Antenna gain, dBi	EIRPSD, dBm/MHz	EIRPSD limit, dBm/MHz	Margin, dB
802.11a	36	5180	1.68	1.24	5.00	6.68	10.00	3.32
	44	5220	1.75	1.20	5.00	6.75	10.00	3.25
	48	5240	1.97	1.76	5.00	6.97	10.00	3.03
802.11n HT20	36	5180	0.55	0.10	5.00	5.55	10.00	4.45
	44	5220	1.05	0.36	5.00	6.05	10.00	3.95
	48	5240	0.71	0.30	5.00	5.71	10.00	4.29
802.11n HT40	38	5190	-4.99	-5.43	5.00	0.01	10.00	9.99
	46	5230	-1.92	-2.38	5.00	3.08	10.00	6.92

Table 8.4-18: PSD measurements results as per ISED for 2.5 dBi antenna gain.

Modulation	Channel	Frequency, MHz	Conducted PSD at ch0, dBm/MHz	Conducted PSD at ch1, dBm/MHz	Antenna gain, dBi	EIRPSD, dBm/MHz	EIRPSD limit, dBm/MHz	Margin, dB
802.11a	36	5180	1.68	1.24	2.50	4.18	10.00	5.82
	44	5220	1.75	1.20	2.50	4.25	10.00	5.75
	48	5240	1.97	1.76	2.50	4.47	10.00	5.53
802.11n HT20	36	5180	0.55	0.10	2.50	3.05	10.00	6.95
	44	5220	1.05	0.36	2.50	3.55	10.00	6.45
	48	5240	0.71	0.30	2.50	3.21	10.00	6.79
802.11n HT40	38	5190	-4.99	-5.43	2.50	-2.49	10.00	12.49
	46	5230	-1.92	-2.38	2.50	0.58	10.00	9.42

Table 8.4-19: Elevation gain requirements

Antenna	On-axis gain ¹ , dBi	Off-axis gain ² , dBi	Off-axis EIRP, dBm	Off-axis EIRP limit, dBm	Margin
ANT793-8DJ	9.2	-7.8	6.44	21.00	14.56
ANT793-8DP	9.1	2.1	16.34	21.00	4.66
ANT795-6DC	9.0	2.0	16.24	21.00	4.76
ANT793-6DG	9.0	5.0	19.24	21.00	1.76

Notes: ¹On-axis gain is the gain at any elevation angle below 30° and it includes cable loss.

²Off-axis gain is the gain at any elevation angle above 30° and it includes cable loss.

Only antenna configurations with On-axis EIRP greater than 21 dBm were verified for elevation gain compliance. All other antennas (On-axis EIRP less than 21 dBm) are deemed to be already compliant.

Section 8

Test name

Specification

Testing data
FCC 15.407(a)(1) and RSS-247 6.2.2(1) 5.15–5.25 GHz band output power and spectral density limits
FCC Part 15 Subpart E and RSS-247, Issue 1

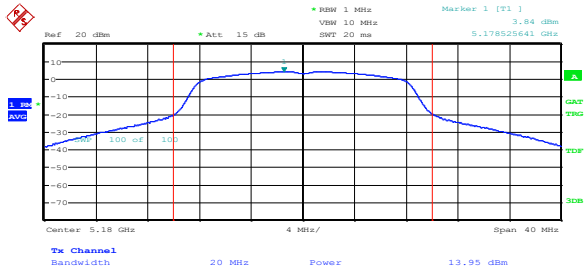

Date: 5.DEC.2016 14:57:27

Figure 8.4-1: Sample plot for power and PPSD on 802.11a

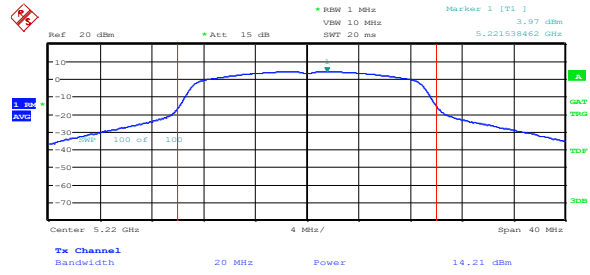

Date: 5.DEC.2016 15:14:09

Figure 8.4-2: Sample plot for power and PPSD on 802.11n HT20

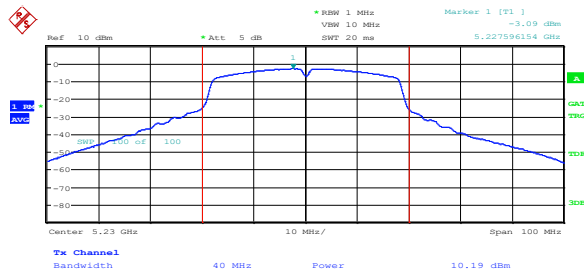

Date: 7.DEC.2016 16:40:56

Figure 8.4-3: Sample plot for power and PPSD on 802.11n HT40



8.5 FCC 15.407(a)(2) and RSS-247 6.2.2(1) 5.25–5.35 GHz band output power and spectral density limits

8.5.1 Definitions and limits

FCC:

The maximum conducted output power over the frequency bands of operation shall not exceed the lesser of 250 mW (24 dBm) or 11 dBm + 10 log₁₀(B), where B is the 26 dB emission bandwidth in megahertz. In addition, the maximum power spectral density shall not exceed 11 dBm in any 1 megahertz band. If transmitting antennas of directional gain greater than 6 dBi are used, both the maximum conducted output power and the maximum power spectral density shall be reduced by the amount in dB that the directional gain of the antenna exceeds 6 dBi.

FCC §15.407(h)(1) Transmit power control (TPC).

U-NII devices shall employ a TPC mechanism. The U-NII device is required to have the capability to operate at least 6 dB below the mean EIRP value of 30 dBm. A TPC mechanism is not required for systems with an e.i.r.p. of less than 500 mW.

ISED:

The maximum conducted output power shall not exceed 250 mW (24 dBm) or 11 + 10 log₁₀(B), dBm, whichever is less, where B is the 99% emission bandwidth in megahertz. The power spectral density shall not exceed 11 dBm in any 1.0 MHz band.

The maximum e.i.r.p. shall not exceed 1.0 W (30 dBm) or 17 + 10 log₁₀(B), dBm, whichever is less. B is the 99% emission bandwidth in megahertz. Note that devices with a maximum e.i.r.p. greater than 500 mW (27 dBm) shall implement TPC in order to have the capability to operate at least 6 dB below the maximum permitted e.i.r.p. of 1 W (30 dBm).

In addition to the above requirements, devices with a maximum e.i.r.p. greater than 200 mW (23 dBm) shall comply with the following e.i.r.p. at different elevations, where θ is the angle above the local horizontal plane (of the Earth) as shown below:

- i. -13 dBW/MHz for 0° ≤ θ < 8°
- ii. -13 - 0.716 (θ-8) dBW/MHz for 8° ≤ θ < 40°
- iii. -35.9 - 1.22 (θ-40) dBW/MHz for 40° ≤ θ ≤ 45°
- iv. -42 dBW/MHz for θ > 45°

8.5.2 Test summary

Test date	December 5, 2016	Temperature	24 °C
Test engineer	Andrey Adelberg	Air pressure	1010 mbar
Verdict	Pass	Relative humidity	34 %

8.5.3 Observations, settings and special notes

In all tables below Output power margin was calculated as the difference between the power limit and highest conducted output power between two antenna ports.

In all tables below EIRP and EIRPSD were calculated as the sum of the antenna gain and highest conducted output power between two antenna ports.

TPC EIRP limit is 24 dBm

As per ISED requirements: since maximum measured EIRP for Canada is 20.08 dBm (below 23 dBm), the EUT is exempt from elevation mask compliance.

Section 8

Testing data

Test name

FCC 15.407(a)(2) and RSS-247 6.2.2(1) 5.25–5.35 GHz band output power and spectral density limits

Specification

FCC Part 15 Subpart E and RSS-247, Issue 1



8.5.4 Test data

Table 8.5-1: Output power measurements results as per FCC for 18 dBi (9.2 dBi with cable loss) antenna gain.

Modulation	Channel	Frequency, MHz	Conducted output power at ch0, dBm	Conducted output power at ch1, dBm	Power limit, dBm	Margin, dB	Antenna gain, dBi	EIRP, dBm	EIRP limit, dBm	Margin, dB
802.11a	52	5260	11.32	10.47	20.80	9.48	9.20	20.52	30.00	9.48
	60	5300	11.25	10.35	20.80	9.55	9.20	20.45	30.00	9.55
	64	5320	11.40	10.57	20.80	9.40	9.20	20.60	30.00	9.40
802.11n HT20	52	5260	11.44	10.66	20.80	9.36	9.20	20.64	30.00	9.36
	60	5300	11.25	10.35	20.80	9.55	9.20	20.45	30.00	9.55
	64	5320	11.38	10.67	20.80	9.42	9.20	20.58	30.00	9.42
802.11n HT40	54	5270	8.34	7.68	20.80	12.46	9.20	17.54	30.00	12.46
	62	5310	8.41	7.89	20.80	12.39	9.20	17.61	30.00	12.39

Table 8.5-2: Output power measurements results as per FCC for 13.5 dBi (9.1 dBi with cable loss) antenna gain.

Modulation	Channel	Frequency, MHz	Conducted output power at ch0, dBm	Conducted output power at ch1, dBm	Power limit, dBm	Margin, dB	Antenna gain, dBi	EIRP, dBm	EIRP limit, dBm	Margin, dB
802.11a	52	5260	11.32	10.47	20.90	9.58	9.10	20.42	30.00	9.58
	60	5300	11.25	10.35	20.90	9.65	9.10	20.35	30.00	9.65
	64	5320	11.40	10.57	20.90	9.50	9.10	20.50	30.00	9.50
802.11n HT20	52	5260	11.44	10.66	20.90	9.46	9.10	20.54	30.00	9.46
	60	5300	11.25	10.35	20.90	9.65	9.10	20.35	30.00	9.65
	64	5320	11.38	10.67	20.90	9.52	9.10	20.48	30.00	9.52
802.11n HT40	54	5270	8.34	7.68	20.90	12.56	9.10	17.44	30.00	12.56
	62	5310	8.41	7.89	20.90	12.49	9.10	17.51	30.00	12.49

Table 8.5-3: Output power measurements results as per FCC for 9 dBi antenna gain.

Modulation	Channel	Frequency, MHz	Conducted output power at ch0, dBm	Conducted output power at ch1, dBm	Power limit, dBm	Margin, dB	Antenna gain, dBi	EIRP, dBm	EIRP limit, dBm	Margin, dB
802.11a	52	5260	11.32	10.47	21.00	9.68	9.00	20.32	30.00	9.68
	60	5300	11.25	10.35	21.00	9.75	9.00	20.25	30.00	9.75
	64	5320	11.40	10.57	21.00	9.60	9.00	20.40	30.00	9.60
802.11n HT20	52	5260	11.44	10.66	21.00	9.56	9.00	20.44	30.00	9.56
	60	5300	11.25	10.35	21.00	9.75	9.00	20.25	30.00	9.75
	64	5320	11.38	10.67	21.00	9.62	9.00	20.38	30.00	9.62
802.11n HT40	54	5270	8.34	7.68	21.00	12.66	9.00	17.34	30.00	12.66
	62	5310	8.41	7.89	21.00	12.59	9.00	17.41	30.00	12.59

Section 8

Testing data

Test name

FCC 15.407(a)(2) and RSS-247 6.2.2(1) 5.25–5.35 GHz band output power and spectral density limits

Specification

FCC Part 15 Subpart E and RSS-247, Issue 1



Table 8.5-4: Output power measurements results as per FCC for 8 dBi (3.6 dBi with cable loss) antenna gain.

Modulation	Channel	Frequency, MHz	Conducted output power at ch0, dBm	Conducted output power at ch1, dBm	Power limit, dBm	Margin, dB	Antenna gain, dBi	EIRP, dBm	EIRP limit, dBm	Margin, dB
802.11a	52	5260	11.32	10.47	24.00	12.68	3.60	14.92	30.00	15.08
	60	5300	11.25	10.35	24.00	12.75	3.60	14.85	30.00	15.15
	64	5320	11.40	10.57	24.00	12.60	3.60	15.00	30.00	15.00
802.11n HT20	52	5260	11.44	10.66	24.00	12.56	3.60	15.04	30.00	14.96
	60	5300	11.25	10.35	24.00	12.75	3.60	14.85	30.00	15.15
	64	5320	11.38	10.67	24.00	12.62	3.60	14.98	30.00	15.02
802.11n HT40	54	5270	8.34	7.68	24.00	15.66	3.60	11.94	30.00	18.06
	62	5310	8.41	7.89	24.00	15.59	3.60	12.01	30.00	17.99

Table 8.5-5: Output power measurements results as per FCC for 7 dBi (2.6 dBi with cable loss) antenna gain.

Modulation	Channel	Frequency, MHz	Conducted output power at ch0, dBm	Conducted output power at ch1, dBm	Power limit, dBm	Margin, dB	Antenna gain, dBi	EIRP, dBm	EIRP limit, dBm	Margin, dB
802.11a	52	5260	11.32	10.47	24.00	12.68	2.60	13.92	30.00	16.08
	60	5300	11.25	10.35	24.00	12.75	2.60	13.85	30.00	16.15
	64	5320	11.40	10.57	24.00	12.60	2.60	14.00	30.00	16.00
802.11n HT20	52	5260	11.44	10.66	24.00	12.56	2.60	14.04	30.00	15.96
	60	5300	11.25	10.35	24.00	12.75	2.60	13.85	30.00	16.15
	64	5320	11.38	10.67	24.00	12.62	2.60	13.98	30.00	16.02
802.11n HT40	54	5270	8.34	7.68	24.00	15.66	2.60	10.94	30.00	19.06
	62	5310	8.41	7.89	24.00	15.59	2.60	11.01	30.00	18.99

Table 8.5-6: Output power measurements results as per FCC for 6 dBi antenna gain.

Modulation	Channel	Frequency, MHz	Conducted output power at ch0, dBm	Conducted output power at ch1, dBm	Power limit, dBm	Margin, dB	Antenna gain, dBi	EIRP, dBm	EIRP limit, dBm	Margin, dB
802.11a	52	5260	11.32	10.47	24.00	12.68	6.00	17.32	30.00	12.68
	60	5300	11.25	10.35	24.00	12.75	6.00	17.25	30.00	12.75
	64	5320	11.40	10.57	24.00	12.60	6.00	17.40	30.00	12.60
802.11n HT20	52	5260	11.44	10.66	24.00	12.56	6.00	17.44	30.00	12.56
	60	5300	11.25	10.35	24.00	12.75	6.00	17.25	30.00	12.75
	64	5320	11.38	10.67	24.00	12.62	6.00	17.38	30.00	12.62
802.11n HT40	54	5270	8.34	7.68	24.00	15.66	6.00	14.34	30.00	15.66
	62	5310	8.41	7.89	24.00	15.59	6.00	14.41	30.00	15.59

Table 8.5-7: Output power measurements results as per FCC for 5 dBi antenna gain.

Modulation	Channel	Frequency, MHz	Conducted output power at ch0, dBm	Conducted output power at ch1, dBm	Power limit, dBm	Margin, dB	Antenna gain, dBi	EIRP, dBm	EIRP limit, dBm	Margin, dB
802.11a	52	5260	11.32	10.47	24.00	12.68	5.00	16.32	30.00	13.68
	60	5300	11.25	10.35	24.00	12.75	5.00	16.25	30.00	13.75
	64	5320	11.40	10.57	24.00	12.60	5.00	16.40	30.00	13.60
802.11n HT20	52	5260	11.44	10.66	24.00	12.56	5.00	16.44	30.00	13.56
	60	5300	11.25	10.35	24.00	12.75	5.00	16.25	30.00	13.75
	64	5320	11.38	10.67	24.00	12.62	5.00	16.38	30.00	13.62
802.11n HT40	54	5270	8.34	7.68	24.00	15.66	5.00	13.34	30.00	16.66
	62	5310	8.41	7.89	24.00	15.59	5.00	13.41	30.00	16.59

Section 8

Testing data

Test name

FCC 15.407(a)(2) and RSS-247 6.2.2(1) 5.25–5.35 GHz band output power and spectral density limits

Specification

FCC Part 15 Subpart E and RSS-247, Issue 1



Table 8.5-8: Output power measurements results as per FCC for 2.5 dBi antenna gain.

Modulation	Channel	Frequency, MHz	Conducted output power at ch0, dBm	Conducted output power at ch1, dBm	Power limit, dBm	Margin, dB	Antenna gain, dBi	EIRP, dBm	EIRP limit, dBm	Margin, dB
802.11a	52	5260	11.32	10.47	24.00	12.68	2.50	13.82	30.00	16.18
	60	5300	11.25	10.35	24.00	12.75	2.50	13.75	30.00	16.25
	64	5320	11.40	10.57	24.00	12.60	2.50	13.90	30.00	16.10
802.11n HT20	52	5260	11.44	10.66	24.00	12.56	2.50	13.94	30.00	16.06
	60	5300	11.25	10.35	24.00	12.75	2.50	13.75	30.00	16.25
	64	5320	11.38	10.67	24.00	12.62	2.50	13.88	30.00	16.12
802.11n HT40	54	5270	8.34	7.68	24.00	15.66	2.50	10.84	30.00	19.16
	62	5310	8.41	7.89	24.00	15.59	2.50	10.91	30.00	19.09

Table 8.5-9: PSD measurements results as per FCC for 18 dBi (9.2 dBi with cable loss) antenna gain.

Modulation	Channel	Frequency, MHz	Conducted PSD at ch0, dBm/MHz	Conducted PSD at ch1, dBm/MHz	PSD limit, dBm/MHz	Margin, dB
802.11a	52	5260	1.19	0.33	7.80	6.61
	60	5300	1.12	0.22	7.80	6.68
	64	5320	1.26	0.43	7.80	6.54
802.11n HT20	52	5260	1.19	0.41	7.80	6.61
	60	5300	0.99	0.12	7.80	6.81
	64	5320	1.13	0.38	7.80	6.67
802.11n HT40	54	5270	-4.90	-5.57	7.80	12.70
	62	5310	-4.80	-5.33	7.80	12.60

Table 8.5-10: PSD measurements results as per FCC for 13.5 dBi (9.1 dBi with cable loss) antenna gain.

Modulation	Channel	Frequency, MHz	Conducted PSD at ch0, dBm/MHz	Conducted PSD at ch1, dBm/MHz	PSD limit, dBm/MHz	Margin, dB
802.11a	52	5260	1.19	0.33	7.90	6.71
	60	5300	1.12	0.22	7.90	6.78
	64	5320	1.26	0.43	7.90	6.64
802.11n HT20	52	5260	1.19	0.41	7.90	6.71
	60	5300	0.99	0.12	7.90	6.91
	64	5320	1.13	0.38	7.90	6.77
802.11n HT40	54	5270	-4.90	-5.57	7.90	12.80
	62	5310	-4.80	-5.33	7.90	12.70

Table 8.5-11: PSD measurements results as per FCC for 9 dBi antenna gain.

Modulation	Channel	Frequency, MHz	Conducted PSD at ch0, dBm/MHz	Conducted PSD at ch1, dBm/MHz	PSD limit, dBm/MHz	Margin, dB
802.11a	52	5260	1.19	0.33	8.00	6.81
	60	5300	1.12	0.22	8.00	6.88
	64	5320	1.26	0.43	8.00	6.74
802.11n HT20	52	5260	1.19	0.41	8.00	6.81
	60	5300	0.99	0.12	8.00	7.01
	64	5320	1.13	0.38	8.00	6.87
802.11n HT40	54	5270	-4.90	-5.57	8.00	12.90
	62	5310	-4.80	-5.33	8.00	12.80

Section 8

Testing data

Test name

FCC 15.407(a)(2) and RSS-247 6.2.2(1) 5.25–5.35 GHz band output power and spectral density limits

Specification

FCC Part 15 Subpart E and RSS-247, Issue 1



Table 8.5-12: PSD measurements results as per FCC for 6 dBi, 5 dBi, 2.5 dBi, 8 dBi (3.6 dBi with cable loss), and 7 dBi (2.6 dBi with cable loss) antenna gains.

Modulation	Channel	Frequency, MHz	Conducted PSD at ch0, dBm/MHz	Conducted PSD at ch1, dBm/MHz	PSD limit, dBm/MHz	Margin, dB
802.11a	52	5260	1.19	0.33	11.00	9.81
	60	5300	1.12	0.22	11.00	9.88
	64	5320	1.26	0.43	11.00	9.74
802.11n HT20	52	5260	1.19	0.41	11.00	9.81
	60	5300	0.99	0.12	11.00	10.01
	64	5320	1.13	0.38	11.00	9.87
802.11n HT40	54	5270	-4.90	-5.57	11.00	15.90
	62	5310	-4.80	-5.33	11.00	15.80

Table 8.5-13: Output power measurements results as per ISSED for 6 dBi antenna gain.

Modulation	Channel	Frequency, MHz	Conducted output power at ch0, dBm	Conducted output power at ch1, dBm	Power limit, dBm	Margin, dB	Antenna gain, dBi	EIRP, dBm	EIRP limit, dBm	Margin, dB
802.11a	52	5260	-1.23	-2.08	23.28	24.51	6.00	4.77	29.28	24.51
	60	5300	11.25	10.35	23.28	12.03	6.00	17.25	29.28	12.03
	64	5320	11.40	10.57	23.28	11.88	6.00	17.40	29.28	11.88
802.11n HT20	52	5260	-1.34	-2.62	23.56	24.90	6.00	4.66	29.56	24.90
	60	5300	11.25	10.35	23.56	12.31	6.00	17.25	29.56	12.31
	64	5320	11.38	10.67	23.56	12.18	6.00	17.38	29.56	12.18
802.11n HT40	54	5270	3.43	2.51	24.00	20.57	6.00	9.43	30.00	20.57
	62	5310	8.41	7.89	24.00	15.59	6.00	14.41	30.00	15.59

Table 8.5-14: Output power measurements results as per ISSED for 5 dBi antenna gain.

Modulation	Channel	Frequency, MHz	Conducted output power at ch0, dBm	Conducted output power at ch1, dBm	Power limit, dBm	Margin, dB	Antenna gain, dBi	EIRP, dBm	EIRP limit, dBm	Margin, dB
802.11a	52	5260	-1.23	-2.08	23.28	24.51	5.00	3.77	29.28	25.51
	60	5300	11.25	10.35	23.28	12.03	5.00	16.25	29.28	13.03
	64	5320	11.40	10.57	23.28	11.88	5.00	16.40	29.28	12.88
802.11n HT20	52	5260	-1.34	-2.62	23.56	24.90	5.00	3.66	29.56	25.90
	60	5300	11.25	10.35	23.56	12.31	5.00	16.25	29.56	13.31
	64	5320	11.38	10.67	23.56	12.18	5.00	16.38	29.56	13.18
802.11n HT40	54	5270	3.43	2.51	24.00	20.57	5.00	8.43	30.00	21.57
	62	5310	8.41	7.89	24.00	15.59	5.00	13.41	30.00	16.59

Table 8.5-15: Output power measurements results as per ISSED for 2.5 dBi antenna gain.

Modulation	Channel	Frequency, MHz	Conducted output power at ch0, dBm	Conducted output power at ch1, dBm	Power limit, dBm	Margin, dB	Antenna gain, dBi	EIRP, dBm	EIRP limit, dBm	Margin, dB
802.11a	52	5260	-1.23	-2.08	23.28	24.51	2.50	1.27	29.28	28.01
	60	5300	11.25	10.35	23.28	12.03	2.50	13.75	29.28	15.53
	64	5320	11.40	10.57	23.28	11.88	2.50	13.90	29.28	15.38
802.11n HT20	52	5260	-1.34	-2.62	23.56	24.90	2.50	1.16	29.56	28.40
	60	5300	11.25	10.35	23.56	12.31	2.50	13.75	29.56	15.81
	64	5320	11.38	10.67	23.56	12.18	2.50	13.88	29.56	15.68
802.11n HT40	54	5270	3.43	2.51	24.00	20.57	2.50	5.93	30.00	24.07
	62	5310	8.41	7.89	24.00	15.59	2.50	10.91	30.00	19.09

Section 8

Testing data

Test name

FCC 15.407(a)(2) and RSS-247 6.2.2(1) 5.25–5.35 GHz band output power and spectral density limits

Specification

FCC Part 15 Subpart E and RSS-247, Issue 1



Table 8.5-16: PSD measurements results as per ISED for 6 dBi antenna gain.

Modulation	Channel	Frequency, MHz	Conducted PSD at ch0, dBm/MHz	Conducted PSD at ch1, dBm/MHz	PSD limit, dBm/MHz	Margin, dB	Antenna gain, dBi	EIRPSD, dBm/MHz	EIRPSD limit, dBm/MHz	Margin, dB
802.11a	52	5260	-11.41	-12.26	11.00	22.41	6.00	-5.41	17.00	22.41
	60	5300	1.12	0.22	11.00	9.88	6.00	7.12	17.00	9.88
	64	5320	1.26	0.43	11.00	9.74	6.00	7.26	17.00	9.74
802.11n HT20	52	5260	-11.61	-12.94	11.00	22.61	6.00	-5.61	17.00	22.61
	60	5300	0.99	0.12	11.00	10.01	6.00	6.99	17.00	10.01
	64	5320	1.13	0.38	11.00	9.87	6.00	7.13	17.00	9.87
802.11n HT40	54	5270	-9.83	-10.75	11.00	20.83	6.00	-3.83	17.00	20.83
	62	5310	-4.80	-5.33	11.00	15.80	6.00	1.20	17.00	15.80

Table 8.5-17: PSD measurements results as per ISED for 5 dBi antenna gain.

Modulation	Channel	Frequency, MHz	Conducted PSD at ch0, dBm/MHz	Conducted PSD at ch1, dBm/MHz	PSD limit, dBm/MHz	Margin, dB	Antenna gain, dBi	EIRPSD, dBm/MHz	EIRPSD limit, dBm/MHz	Margin, dB
802.11a	22.41	5.00	-6.41	17.00	23.41	22.41	5.00	-6.41	17.00	23.41
	9.88	5.00	6.12	17.00	10.88	9.88	5.00	6.12	17.00	10.88
	9.74	5.00	6.26	17.00	10.74	9.74	5.00	6.26	17.00	10.74
802.11n HT20	22.61	5.00	-6.61	17.00	23.61	22.61	5.00	-6.61	17.00	23.61
	10.01	5.00	5.99	17.00	11.01	10.01	5.00	5.99	17.00	11.01
	9.87	5.00	6.13	17.00	10.87	9.87	5.00	6.13	17.00	10.87
802.11n HT40	20.83	5.00	-4.83	17.00	21.83	20.83	5.00	-4.83	17.00	21.83
	15.80	5.00	0.20	17.00	16.80	15.80	5.00	0.20	17.00	16.80

Table 8.5-18: PSD measurements results as per ISED for 2.5 dBi antenna gain.

Modulation	Channel	Frequency, MHz	Conducted PSD at ch0, dBm/MHz	Conducted PSD at ch1, dBm/MHz	PSD limit, dBm/MHz	Margin, dB	Antenna gain, dBi	EIRPSD, dBm/MHz	EIRPSD limit, dBm/MHz	Margin, dB
802.11a	22.41	5.00	-6.41	17.00	23.41	22.41	2.50	-8.91	17.00	25.91
	9.88	5.00	6.12	17.00	10.88	9.88	2.50	3.62	17.00	13.38
	9.74	5.00	6.26	17.00	10.74	9.74	2.50	3.76	17.00	13.24
802.11n HT20	22.61	5.00	-6.61	17.00	23.61	22.61	2.50	-9.11	17.00	26.11
	10.01	5.00	5.99	17.00	11.01	10.01	2.50	3.49	17.00	13.51
	9.87	5.00	6.13	17.00	10.87	9.87	2.50	3.63	17.00	13.37
802.11n HT40	20.83	5.00	-4.83	17.00	21.83	20.83	2.50	-7.33	17.00	24.33
	15.80	5.00	0.20	17.00	16.80	15.80	2.50	-2.30	17.00	19.30

Table 8.5-19: TPC measurements results

Modulation	Channel	Frequency, MHz	Output power at ch0, dBm	Output power at ch1, dBm	Antenna gain, dBi	EIRP, dBm	TPC EIRP limit, dBm	Margin, dB
802.11a	52	5260	0.96	0.91	9.00	9.96	24.00	14.04
	60	5300	0.94	1.18	9.00	10.18	24.00	13.82
	64	5320	1.05	0.26	9.00	10.05	24.00	13.95
802.11n HT20	52	5260	0.83	0.73	9.00	9.83	24.00	14.17
	60	5300	0.91	1.14	9.00	10.14	24.00	13.86
	64	5320	0.97	0.05	9.00	9.97	24.00	14.03
802.11n HT40	54	5270	3.92	3.97	9.00	12.97	24.00	11.03
	62	5310	0.75	-2.11	9.00	9.75	24.00	14.25

Section 8

Testing data

Test name

FCC 15.407(a)(2) and RSS-247 6.2.2(1) 5.25–5.35 GHz band output power and spectral density limits

Specification

FCC Part 15 Subpart E and RSS-247, Issue 1

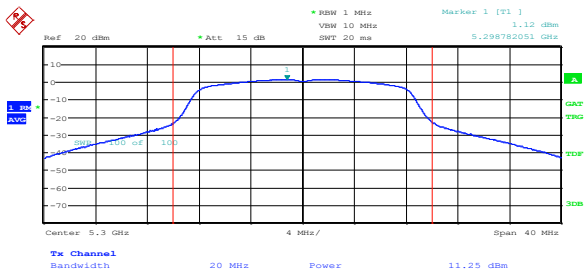

Date: 5.DEC.2016 15:00:39

Figure 8.5-1: Sample plot for power and PPSD on 802.11a

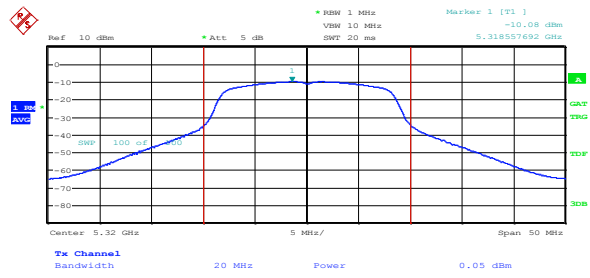

Date: 9.DEC.2016 14:52:55

Figure 8.5-2: Sample plot for power and PPSD on 802.11n HT20

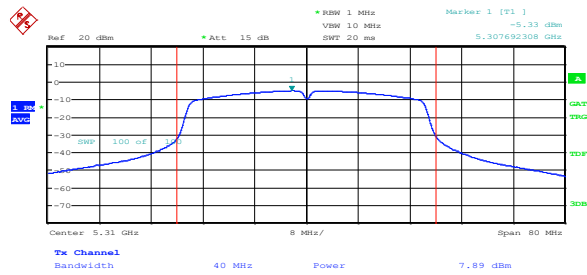

Date: 5.DEC.2016 15:33:27

Figure 8.5-3: Sample plot for power and PPSD on 802.11n HT40



8.6 FCC 15.407(a)(2) and RSS-247 6.2.3(1) 5.47–5.725 GHz band output power and spectral density limits

8.6.1 Definitions and limits

FCC:

The maximum conducted output power over the frequency bands of operation shall not exceed the lesser of 250 mW (24 dBm) or $11 \text{ dBm} + 10 \log_{10}(B)$, where B is the 26 dB emission bandwidth in megahertz. In addition, the maximum power spectral density shall not exceed 11 dBm in any 1 megahertz band. If transmitting antennas of directional gain greater than 6 dBi are used, both the maximum conducted output power and the maximum power spectral density shall be reduced by the amount in dB that the directional gain of the antenna exceeds 6 dBi.

FCC §15.407(h)(1) Transmit power control (TPC).

U-NII devices shall employ a TPC mechanism. The U-NII device is required to have the capability to operate at least 6 dB below the mean EIRP value of 30 dBm. A TPC mechanism is not required for systems with an e.i.r.p. of less than 500 mW.

ISED:

Until further notice, devices subject to this section shall not be capable of transmitting in the band 5600–5650 MHz. This restriction is for the protection of Environment Canada’s weather radars operating in this band.

The maximum conducted output power shall not exceed 250 mW (24 dBm) or $11 + 10 \log_{10}B$, dBm, whichever is less. The power spectral density shall not exceed 11 dBm in any 1.0 MHz band.

The maximum e.i.r.p. shall not exceed 1.0 W (30 dBm) or $17 + 10 \log_{10}B$, dBm, whichever is less. B is the 99% emission bandwidth in megahertz. Note that devices with a maximum e.i.r.p. greater than 500 mW shall implement TPC in order to have the capability to operate at least 6 dB below the maximum permitted e.i.r.p. of 1 W.

8.6.2 Test summary

Test date	December 5, 2016	Temperature	24 °C
Test engineer	Andrey Adelberg	Air pressure	1010 mbar
Verdict	Pass	Relative humidity	34 %

8.6.3 Observations, settings and special notes

In all tables below Output power margin was calculated as the difference between the power limit and highest conducted output power between two antenna ports.

In all tables below EIRP and EIRPSD were calculated as the sum of the antenna gain and highest conducted output power between two antenna ports.

TPC EIRP limit is 24 dBm



8.6.4 Test data

Table 8.6-1: Output power measurements results as per FCC for 18 dBi (9.2 dBi with cable loss) antenna gain.

Modulation	Channel	Frequency, MHz	Conducted output power at ch0, dBm	Conducted output power at ch1, dBm	Power limit, dBm	Margin, dB	Antenna gain, dBi	EIRP, dBm	EIRP limit, dBm	Margin, dB
802.11a	100	5500	11.90	10.47	20.80	8.90	9.20	21.10	30.00	8.90
	116	5580	12.70	11.48	20.80	8.10	9.20	21.90	30.00	8.10
	140	5700	8.89	8.26	20.80	11.91	9.20	18.09	30.00	11.91
802.11n HT20	100	5500	12.00	10.56	20.80	8.80	9.20	21.20	30.00	8.80
	116	5580	12.73	11.51	20.80	8.07	9.20	21.93	30.00	8.07
	140	5700	8.89	8.43	20.80	11.91	9.20	18.09	30.00	11.91
802.11n HT40	102	5510	8.78	7.03	20.80	12.02	9.20	17.98	30.00	12.02
	110	5550	9.55	7.93	20.80	11.25	9.20	18.75	30.00	11.25
	134	5670	9.06	8.69	20.80	11.74	9.20	18.26	30.00	11.74

Table 8.6-2: Output power measurements results as per FCC for 13.5 dBi (9.1 dBi with cable loss) antenna gain.

Modulation	Channel	Frequency, MHz	Conducted output power at ch0, dBm	Conducted output power at ch1, dBm	Power limit, dBm	Margin, dB	Antenna gain, dBi	EIRP, dBm	EIRP limit, dBm	Margin, dB
802.11a	100	5500	11.90	10.47	20.90	9.00	9.10	21.00	30.00	9.00
	116	5580	12.70	11.48	20.90	8.20	9.10	21.80	30.00	8.20
	140	5700	8.89	8.26	20.90	12.01	9.10	17.99	30.00	12.01
802.11n HT20	100	5500	12.00	10.56	20.90	8.90	9.10	21.10	30.00	8.90
	116	5580	12.73	11.51	20.90	8.17	9.10	21.83	30.00	8.17
	140	5700	8.89	8.43	20.90	12.01	9.10	17.99	30.00	12.01
802.11n HT40	102	5510	8.78	7.03	20.90	12.12	9.10	17.88	30.00	12.12
	110	5550	9.55	7.93	20.90	11.35	9.10	18.65	30.00	11.35
	134	5670	9.06	8.69	20.90	11.84	9.10	18.16	30.00	11.84

Table 8.6-3: Output power measurements results as per FCC for 9 dBi antenna gain.

Modulation	Channel	Frequency, MHz	Conducted output power at ch0, dBm	Conducted output power at ch1, dBm	Power limit, dBm	Margin, dB	Antenna gain, dBi	EIRP, dBm	EIRP limit, dBm	Margin, dB
802.11a	100	5500	11.90	10.47	21.00	9.10	9.00	20.90	30.00	9.10
	116	5580	12.70	11.48	21.00	8.30	9.00	21.70	30.00	8.30
	140	5700	8.89	8.26	21.00	12.11	9.00	17.89	30.00	12.11
802.11n HT20	100	5500	12.00	10.56	21.00	9.00	9.00	21.00	30.00	9.00
	116	5580	12.73	11.51	21.00	8.27	9.00	21.73	30.00	8.27
	140	5700	8.89	8.43	21.00	12.11	9.00	17.89	30.00	12.11
802.11n HT40	102	5510	8.78	7.03	21.00	12.22	9.00	17.78	30.00	12.22
	110	5550	9.55	7.93	21.00	11.45	9.00	18.55	30.00	11.45
	134	5670	9.06	8.69	21.00	11.94	9.00	18.06	30.00	11.94

Section 8

Testing data

Test name

FCC 15.407(a)(2) and RSS-247 6.2.3(1) 5.47–5.725 GHz band output power and spectral density limits

Specification

FCC Part 15 Subpart E and RSS-247, Issue 1



Table 8.6-4: Output power measurements results as per FCC for 8 dBi (3.6 dBi with cable loss) antenna gain.

Modulation	Channel	Frequency, MHz	Conducted output power at ch0, dBm	Conducted output power at ch1, dBm	Power limit, dBm	Margin, dB	Antenna gain, dBi	EIRP, dBm	EIRP limit, dBm	Margin, dB
802.11a	100	5500	11.90	10.47	24.00	12.10	3.60	15.50	30.00	14.50
	116	5580	12.70	11.48	24.00	11.30	3.60	16.30	30.00	13.70
	140	5700	8.89	8.26	24.00	15.11	3.60	12.49	30.00	17.51
802.11n HT20	100	5500	12.00	10.56	24.00	12.00	3.60	15.60	30.00	14.40
	116	5580	12.73	11.51	24.00	11.27	3.60	16.33	30.00	13.67
	140	5700	8.89	8.43	24.00	15.11	3.60	12.49	30.00	17.51
802.11n HT40	102	5510	8.78	7.03	24.00	15.22	3.60	12.38	30.00	17.62
	110	5550	9.55	7.93	24.00	14.45	3.60	13.15	30.00	16.85
	134	5670	9.06	8.69	24.00	14.94	3.60	12.66	30.00	17.34

Table 8.6-5: Output power measurements results as per FCC for 7 dBi (2.6 dBi with cable loss) antenna gain.

Modulation	Channel	Frequency, MHz	Conducted output power at ch0, dBm	Conducted output power at ch1, dBm	Power limit, dBm	Margin, dB	Antenna gain, dBi	EIRP, dBm	EIRP limit, dBm	Margin, dB
802.11a	100	5500	11.90	10.47	24.00	12.10	2.60	14.50	30.00	15.50
	116	5580	12.70	11.48	24.00	11.30	2.60	15.30	30.00	14.70
	140	5700	8.89	8.26	24.00	15.11	2.60	11.49	30.00	18.51
802.11n HT20	100	5500	12.00	10.56	24.00	12.00	2.60	14.60	30.00	15.40
	116	5580	12.73	11.51	24.00	11.27	2.60	15.33	30.00	14.67
	140	5700	8.89	8.43	24.00	15.11	2.60	11.49	30.00	18.51
802.11n HT40	102	5510	8.78	7.03	24.00	15.22	2.60	11.38	30.00	18.62
	110	5550	9.55	7.93	24.00	14.45	2.60	12.15	30.00	17.85
	134	5670	9.06	8.69	24.00	14.94	2.60	11.66	30.00	18.34

Table 8.6-6: Output power measurements results as per FCC for 6 dBi antenna gain.

Modulation	Channel	Frequency, MHz	Conducted output power at ch0, dBm	Conducted output power at ch1, dBm	Power limit, dBm	Margin, dB	Antenna gain, dBi	EIRP, dBm	EIRP limit, dBm	Margin, dB
802.11a	100	5500	11.90	10.47	24.00	12.10	6.00	17.90	30.00	12.10
	116	5580	12.70	11.48	24.00	11.30	6.00	18.70	30.00	11.30
	140	5700	8.89	8.26	24.00	15.11	6.00	14.89	30.00	15.11
802.11n HT20	100	5500	12.00	10.56	24.00	12.00	6.00	18.00	30.00	12.00
	116	5580	12.73	11.51	24.00	11.27	6.00	18.73	30.00	11.27
	140	5700	8.89	8.43	24.00	15.11	6.00	14.89	30.00	15.11
802.11n HT40	102	5510	8.78	7.03	24.00	15.22	6.00	14.78	30.00	15.22
	110	5550	9.55	7.93	24.00	14.45	6.00	15.55	30.00	14.45
	134	5670	9.06	8.69	24.00	14.94	6.00	15.06	30.00	14.94

Section 8

Testing data

Test name

FCC 15.407(a)(2) and RSS-247 6.2.3(1) 5.47–5.725 GHz band output power and spectral density limits

Specification

FCC Part 15 Subpart E and RSS-247, Issue 1



Table 8.6-7: Output power measurements results as per FCC for 5 dBi antenna gain.

Modulation	Channel	Frequency, MHz	Conducted output power at ch0, dBm	Conducted output power at ch1, dBm	Power limit, dBm	Margin, dB	Antenna gain, dBi	EIRP, dBm	EIRP limit, dBm	Margin, dB
802.11a	100	5500	11.90	10.47	24.00	12.10	5.00	16.90	30.00	13.10
	116	5580	12.70	11.48	24.00	11.30	5.00	17.70	30.00	12.30
	140	5700	8.89	8.26	24.00	15.11	5.00	13.89	30.00	16.11
802.11n HT20	100	5500	12.00	10.56	24.00	12.00	5.00	17.00	30.00	13.00
	116	5580	12.73	11.51	24.00	11.27	5.00	17.73	30.00	12.27
	140	5700	8.89	8.43	24.00	15.11	5.00	13.89	30.00	16.11
802.11n HT40	102	5510	8.78	7.03	24.00	15.22	5.00	13.78	30.00	16.22
	110	5550	9.55	7.93	24.00	14.45	5.00	14.55	30.00	15.45
	134	5670	9.06	8.69	24.00	14.94	5.00	14.06	30.00	15.94

Table 8.6-8: Output power measurements results as per FCC for 2.5 dBi antenna gain.

Modulation	Channel	Frequency, MHz	Conducted output power at ch0, dBm	Conducted output power at ch1, dBm	Power limit, dBm	Margin, dB	Antenna gain, dBi	EIRP, dBm	EIRP limit, dBm	Margin, dB
802.11a	100	5500	11.90	10.47	24.00	12.10	2.50	14.40	30.00	15.60
	116	5580	12.70	11.48	24.00	11.30	2.50	15.20	30.00	14.80
	140	5700	8.89	8.26	24.00	15.11	2.50	11.39	30.00	18.61
802.11n HT20	100	5500	12.00	10.56	24.00	12.00	2.50	14.50	30.00	15.50
	116	5580	12.73	11.51	24.00	11.27	2.50	15.23	30.00	14.77
	140	5700	8.89	8.43	24.00	15.11	2.50	11.39	30.00	18.61
802.11n HT40	102	5510	8.78	7.03	24.00	15.22	2.50	11.28	30.00	18.72
	110	5550	9.55	7.93	24.00	14.45	2.50	12.05	30.00	17.95
	134	5670	9.06	8.69	24.00	14.94	2.50	11.56	30.00	18.44

Table 8.6-9: PSD measurements results as per FCC for 9.2 dBi antenna gain.

Modulation	Channel	Frequency, MHz	Conducted PSD at ch0, dBm/MHz	Conducted PSD at ch1, dBm/MHz	PSD limit, dBm/MHz	Margin, dB
802.11a	100	5500	1.78	0.34	7.80	6.02
	116	5580	2.56	1.34	7.80	5.24
	140	5700	-1.22	-1.78	7.80	9.02
802.11n HT20	100	5500	1.73	0.31	7.80	6.07
	116	5580	2.47	1.26	7.80	5.33
	140	5700	-1.36	-1.84	7.80	9.16
802.11n HT40	102	5510	-4.51	-6.25	7.80	12.31
	110	5550	-3.69	-5.29	7.80	11.49
	134	5670	-4.17	-4.52	7.80	11.97

Table 8.6-10: PSD measurements results as per FCC for 9.1 dBi antenna gain.

Modulation	Channel	Frequency, MHz	Conducted PSD at ch0, dBm/MHz	Conducted PSD at ch1, dBm/MHz	PSD limit, dBm/MHz	Margin, dB
802.11a	100	5500	1.78	0.34	7.90	6.12
	116	5580	2.56	1.34	7.90	5.34
	140	5700	-1.22	-1.78	7.90	9.12
802.11n HT20	100	5500	1.73	0.31	7.90	6.17
	116	5580	2.47	1.26	7.90	5.43
	140	5700	-1.36	-1.84	7.90	9.26
802.11n HT40	102	5510	-4.51	-6.25	7.90	12.41
	110	5550	-3.69	-5.29	7.90	11.59
	134	5670	-4.17	-4.52	7.90	12.07

Section 8

Testing data

Test name

FCC 15.407(a)(2) and RSS-247 6.2.3(1) 5.47–5.725 GHz band output power and spectral density limits

Specification

FCC Part 15 Subpart E and RSS-247, Issue 1



Table 8.6-11: PSD measurements results as per FCC for 9 dBi antenna gain.

Modulation	Channel	Frequency, MHz	Conducted PSD at ch0, dBm/MHz	Conducted PSD at ch1, dBm/MHz	PSD limit, dBm/MHz	Margin, dB
802.11a	100	5500	1.78	0.34	8.00	6.22
	116	5580	2.56	1.34	8.00	5.44
	140	5700	-1.22	-1.78	8.00	9.22
802.11n HT20	100	5500	1.73	0.31	8.00	6.27
	116	5580	2.47	1.26	8.00	5.53
	140	5700	-1.36	-1.84	8.00	9.36
802.11n HT40	102	5510	-4.51	-6.25	8.00	12.51
	110	5550	-3.69	-5.29	8.00	11.69
	134	5670	-4.17	-4.52	8.00	12.17

Table 8.6-12: PSD measurements results as per FCC for 6 dBi, 5 dBi, 2.5 dBi, 8 dBi (3.6 dBi with cable loss), and 7 dBi (2.6 dBi with cable loss) antenna gains.

Modulation	Channel	Frequency, MHz	Conducted PSD at ch0, dBm/MHz	Conducted PSD at ch1, dBm/MHz	PSD limit, dBm/MHz	Margin, dB
802.11a	100	5500	1.78	0.34	11.00	9.22
	116	5580	2.56	1.34	11.00	8.44
	140	5700	-1.22	-1.78	11.00	12.22
802.11n HT20	100	5500	1.73	0.31	11.00	9.27
	116	5580	2.47	1.26	11.00	8.53
	140	5700	-1.36	-1.84	11.00	12.36
802.11n HT40	102	5510	-4.51	-6.25	11.00	15.51
	110	5550	-3.69	-5.29	11.00	14.69
	134	5670	-4.17	-4.52	11.00	15.17

Table 8.6-13: Output power measurements results as per ISSED for 6 dBi antenna gain.

Modulation	Channel	Frequency, MHz	Conducted output power at ch0, dBm	Conducted output power at ch1, dBm	Power limit, dBm	Margin, dB	Antenna gain, dBi	EIRP, dBm	EIRP limit, dBm	Margin, dB
802.11a	100	5500	11.90	10.47	23.28	11.38	6.00	17.90	29.28	11.38
	116	5580	12.70	11.48	23.28	10.58	6.00	18.70	29.28	10.58
	140	5700	8.89	8.26	23.28	14.39	6.00	14.89	29.28	14.39
802.11n HT20	100	5500	12.00	10.56	23.56	11.56	6.00	18.00	29.56	11.56
	116	5580	12.73	11.51	23.56	10.83	6.00	18.73	29.56	10.83
	140	5700	8.89	8.43	23.56	14.67	6.00	14.89	29.56	14.67
802.11n HT40	102	5510	8.78	7.03	24.00	15.22	6.00	14.78	30.00	15.22
	110	5550	9.55	7.93	24.00	14.45	6.00	15.55	30.00	14.45
	134	5670	9.06	8.69	24.00	14.94	6.00	15.06	30.00	14.94

Table 8.6-14: Output power measurements results as per ISSED for 5 dBi antenna gain.

Modulation	Channel	Frequency, MHz	Conducted output power at ch0, dBm	Conducted output power at ch1, dBm	Power limit, dBm	Margin, dB	Antenna gain, dBi	EIRP, dBm	EIRP limit, dBm	Margin, dB
802.11a	100	5500	11.90	10.47	23.28	11.38	5.00	16.90	29.28	12.38
	116	5580	12.70	11.48	23.28	10.58	5.00	17.70	29.28	11.58
	140	5700	8.89	8.26	23.28	14.39	5.00	13.89	29.28	15.39
802.11n HT20	100	5500	12.00	10.56	23.56	11.56	5.00	17.00	29.56	12.56
	116	5580	12.73	11.51	23.56	10.83	5.00	17.73	29.56	11.83
	140	5700	8.89	8.43	23.56	14.67	5.00	13.89	29.56	15.67
802.11n HT40	102	5510	8.78	7.03	24.00	15.22	5.00	13.78	30.00	16.22
	110	5550	9.55	7.93	24.00	14.45	5.00	14.55	30.00	15.45
	134	5670	9.06	8.69	24.00	14.94	5.00	14.06	30.00	15.94

Section 8

Testing data

Test name

FCC 15.407(a)(2) and RSS-247 6.2.3(1) 5.47–5.725 GHz band output power and spectral density limits

Specification

FCC Part 15 Subpart E and RSS-247, Issue 1



Table 8.6-15: Output power measurements results as per ISED for 2.5 dBi antenna gain.

Modulation	Channel	Frequency, MHz	Conducted output power at ch0, dBm	Conducted output power at ch1, dBm	Power limit, dBm	Margin, dB	Antenna gain, dBi	EIRP, dBm	EIRP limit, dBm	Margin, dB
802.11a	100	5500	11.90	10.47	23.28	11.38	2.50	14.40	29.28	14.88
	116	5580	12.70	11.48	23.28	10.58	2.50	15.20	29.28	14.08
	140	5700	8.89	8.26	23.28	14.39	2.50	11.39	29.28	17.89
802.11n HT20	100	5500	12.00	10.56	23.56	11.56	2.50	14.50	29.56	15.06
	116	5580	12.73	11.51	23.56	10.83	2.50	15.23	29.56	14.33
	140	5700	8.89	8.43	23.56	14.67	2.50	11.39	29.56	18.17
802.11n HT40	102	5510	8.78	7.03	24.00	15.22	2.50	11.28	30.00	18.72
	110	5550	9.55	7.93	24.00	14.45	2.50	12.05	30.00	17.95
	134	5670	9.06	8.69	24.00	14.94	2.50	11.56	30.00	18.44

Table 8.6-16: PSD measurements results as per ISED for 6 dBi antenna gain.

Modulation	Channel	Frequency, MHz	Conducted PSD at ch0, dBm/MHz	Conducted PSD at ch1, dBm/MHz	PSD limit, dBm/MHz	Margin, dB	Antenna gain, dBi	EIRPSD, dBm/MHz	EIRPSD limit, dBm/MHz	Margin, dB
802.11a	100	5500	1.78	0.34	11.00	9.22	6.00	7.78	17.00	9.22
	116	5580	2.56	1.34	11.00	8.44	6.00	8.56	17.00	8.44
	140	5700	-1.22	-1.78	11.00	12.22	6.00	4.78	17.00	12.22
802.11n HT20	100	5500	1.73	0.31	11.00	9.27	6.00	7.73	17.00	9.27
	116	5580	2.47	1.26	11.00	8.53	6.00	8.47	17.00	8.53
	140	5700	-1.36	-1.84	11.00	12.36	6.00	4.64	17.00	12.36
802.11n HT40	102	5510	-4.51	-6.25	11.00	15.51	6.00	1.49	17.00	15.51
	110	5550	-3.69	-5.29	11.00	14.69	6.00	2.31	17.00	14.69
	134	5670	-4.17	-4.52	11.00	15.17	6.00	1.83	17.00	15.17

Table 8.6-17: PSD measurements results as per ISED for 5 dBi antenna gain.

Modulation	Channel	Frequency, MHz	Conducted PSD at ch0, dBm/MHz	Conducted PSD at ch1, dBm/MHz	PSD limit, dBm/MHz	Margin, dB	Antenna gain, dBi	EIRPSD, dBm/MHz	EIRPSD limit, dBm/MHz	Margin, dB
802.11a	100	5500	1.78	0.34	11.00	9.22	5.00	6.78	17.00	10.22
	116	5580	2.56	1.34	11.00	8.44	5.00	7.56	17.00	9.44
	140	5700	-1.22	-1.78	11.00	12.22	5.00	3.78	17.00	13.22
802.11n HT20	100	5500	1.73	0.31	11.00	9.27	5.00	6.73	17.00	10.27
	116	5580	2.47	1.26	11.00	8.53	5.00	7.47	17.00	9.53
	140	5700	-1.36	-1.84	11.00	12.36	5.00	3.64	17.00	13.36
802.11n HT40	102	5510	-4.51	-6.25	11.00	15.51	5.00	0.49	17.00	16.51
	110	5550	-3.69	-5.29	11.00	14.69	5.00	1.31	17.00	15.69
	134	5670	-4.17	-4.52	11.00	15.17	5.00	0.83	17.00	16.17

Table 8.6-18: PSD measurements results as per ISED for 2.5 dBi antenna gain.

Modulation	Channel	Frequency, MHz	Conducted PSD at ch0, dBm/MHz	Conducted PSD at ch1, dBm/MHz	PSD limit, dBm/MHz	Margin, dB	Antenna gain, dBi	EIRPSD, dBm/MHz	EIRPSD limit, dBm/MHz	Margin, dB
802.11a	100	5500	1.78	0.34	11.00	9.22	2.50	4.28	17.00	12.72
	116	5580	2.56	1.34	11.00	8.44	2.50	5.06	17.00	11.94
	140	5700	-1.22	-1.78	11.00	12.22	2.50	1.28	17.00	15.72
802.11n HT20	100	5500	1.73	0.31	11.00	9.27	2.50	4.23	17.00	12.77
	116	5580	2.47	1.26	11.00	8.53	2.50	4.97	17.00	12.03
	140	5700	-1.36	-1.84	11.00	12.36	2.50	1.14	17.00	15.86
802.11n HT40	102	5510	-4.51	-6.25	11.00	15.51	2.50	-2.01	17.00	19.01
	110	5550	-3.69	-5.29	11.00	14.69	2.50	-1.19	17.00	18.19
	134	5670	-4.17	-4.52	11.00	15.17	2.50	-1.67	17.00	18.67

Section 8

Testing data

Test name

FCC 15.407(a)(2) and RSS-247 6.2.3(1) 5.47–5.725 GHz band output power and spectral density limits

Specification

FCC Part 15 Subpart E and RSS-247, Issue 1



Table 8.6-19: TPC measurements results

Modulation	Channel	Frequency, MHz	Output power at ch0, dBm	Output power at ch1, dBm	Antenna gain, dBi	EIRP, dBm	TPC EIRP limit, dBm	Margin, dB
802.11a	100	5500	1.49	0.74	9.00	10.49	23.00	12.51
	116	5580	0.90	1.14	9.00	10.14	23.00	12.86
	140	5700	1.26	0.88	9.00	10.26	23.00	12.74
802.11n HT20	100	5500	1.41	1.07	9.00	10.41	23.00	12.59
	116	5580	1.42	1.03	9.00	10.42	23.00	12.58
	140	5700	1.18	0.94	9.00	10.18	23.00	12.82
802.11n HT40	102	5510	3.85	3.93	9.00	12.93	23.00	10.07
	110	5550	3.84	3.56	9.00	12.84	23.00	10.16
	134	5670	3.52	3.56	9.00	12.56	23.00	10.44

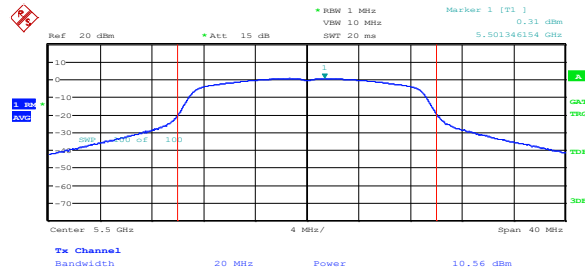
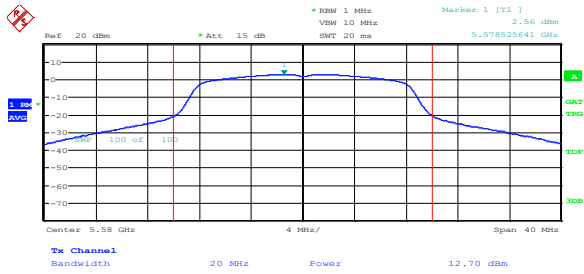

Date: 5.DEC.2016 15:03:11

Date: 5.DEC.2016 15:20:36

Figure 8.6-1: Sample plot for power and PPSD on 802.11a

Figure 8.6-2: Sample plot for power and PPSD on 802.11n HT20

Section 8

Test name

Specification

Testing data

FCC 15.407(a)(2) and RSS-247 6.2.3(1) 5.47–5.725 GHz band output power and spectral density limits

FCC Part 15 Subpart E and RSS-247, Issue 1

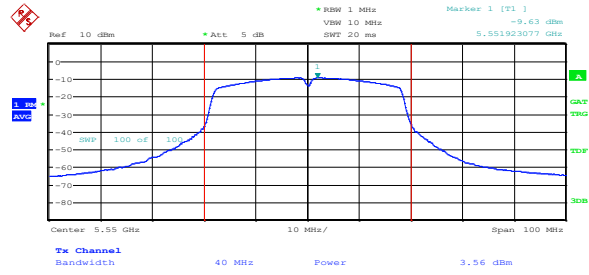

Date: 9.DEC.2016 15:35:06

Figure 8.6-3: Sample plot for power and PPSD on 802.11n HT40



8.7 FCC 15.407(a)(3) and RSS-247 6.2.4(1) 5.725–5.850 GHz band output power and spectral density limits

8.7.1 Definitions and limits

FCC:
 For the band 5.725–5.85 GHz, the maximum conducted output power over the frequency band of operation shall not exceed 1 W. In addition, the maximum power spectral density shall not exceed 30 dBm in any 500-kHz band. If transmitting antennas of directional gain greater than 6 dBi are used, both the maximum conducted output power and the maximum power spectral density shall be reduced by the amount in dB that the directional gain of the antenna exceeds 6 dBi. However, fixed point-to-point U-NII devices operating in this band may employ transmitting antennas with directional gain greater than 6 dBi without any corresponding reduction in transmitter conducted power. Fixed, point-to-point operations exclude the use of point-to-multipoint systems, omnidirectional applications, and multiple collocated transmitters transmitting the same information. The operator of the U-NII device, or if the equipment is professionally installed, the installer, is responsible for ensuring that systems employing high gain directional antennas are used exclusively for fixed, point-to-point operations.

ISED:
 The maximum conducted output power shall not exceed 1 W. The power spectral density shall not exceed 30 dBm in any 500 kHz band. If transmitting antennas of directional gain greater than 6 dBi are used, both the maximum conducted output power and the power spectral density shall be reduced by the amount in dB that the directional gain of the antenna exceeds 6 dBi. However, fixed point-to-point devices operating in this band may employ transmitting antennas with directional gain greater than 6 dBi without any corresponding reduction in transmitter conducted power. Fixed point-to-point operations exclude the use of point-to-multipoint systems, omnidirectional applications and multiple collocated transmitters transmitting the same information.

8.7.2 Test summary

Test date	December 14, 2016	Temperature	21 °C
Test engineer	Andrey Adelberg	Air pressure	1008 mbar
Verdict	Pass	Relative humidity	36 %

8.7.3 Observations, settings and special notes

In all tables below Output power margin was calculated as the difference between the power limit and highest conducted output power between two antenna ports.
 In all tables below EIRP and EIRPSD were calculated as the sum of the antenna gain and highest conducted output power between two antenna ports.

8.7.4 Test data

Table 8.7-1: Output power measurements results as per FCC for 18 dBi (9.2 dBi with cable loss) antenna gain.

Modulation	Channel	Frequency, MHz	Conducted output power at ch0, dBm	Conducted output power at ch1, dBm	Power limit, dBm	Margin, dB	Antenna gain, dBi	EIRP, dBm	EIRP limit, dBm	Margin, dB
802.11a	149	5745	10.17	8.96	26.80	16.63	9.20	19.37	36.00	16.63
	157	5785	14.46	13.80	26.80	12.34	9.20	23.66	36.00	12.34
	165	5825	11.44	10.67	26.80	15.36	9.20	20.64	36.00	15.36
802.11n HT20	149	5745	10.32	8.92	26.80	16.48	9.20	19.52	36.00	16.48
	157	5785	14.30	13.39	26.80	12.50	9.20	23.50	36.00	12.50
802.11n HT40	165	5825	11.42	10.65	26.80	15.38	9.20	20.62	36.00	15.38
	151	5755	10.10	8.97	26.80	16.70	9.20	19.30	36.00	16.70
	159	5795	12.09	11.30	26.80	14.71	9.20	21.29	36.00	14.71

Section 8

Testing data

Test name

FCC 15.407(a)(3) and RSS-247 6.2.4(1) 5.725–5.850 GHz band output power and spectral density limits

Specification

FCC Part 15 Subpart E and RSS-247, Issue 1



Table 8.7-2: Output power measurements results as per FCC for 13.5 dBi (9.1 dBi with cable loss) antenna gain.

Modulation	Channel	Frequency, MHz	Conducted output power at ch0, dBm	Conducted output power at ch1, dBm	Power limit, dBm	Margin, dB	Antenna gain, dBi	EIRP, dBm	EIRP limit, dBm	Margin, dB
802.11a	149	5745	10.17	8.96	26.90	16.73	9.10	19.27	36.00	16.73
	157	5785	14.46	13.80	26.90	12.44	9.10	23.56	36.00	12.44
	165	5825	11.44	10.67	26.90	15.46	9.10	20.54	36.00	15.46
802.11n HT20	149	5745	10.32	8.92	26.90	16.58	9.10	19.42	36.00	16.58
	157	5785	14.30	13.39	26.90	12.60	9.10	23.40	36.00	12.60
	165	5825	11.42	10.65	26.90	15.48	9.10	20.52	36.00	15.48
802.11n HT40	151	5755	10.10	8.97	26.90	16.80	9.10	19.20	36.00	16.80
	159	5795	12.09	11.30	26.90	14.81	9.10	21.19	36.00	14.81

Table 8.7-3: Output power measurements results as per FCC for 9 dBi antenna gain.

Modulation	Channel	Frequency, MHz	Conducted output power at ch0, dBm	Conducted output power at ch1, dBm	Power limit, dBm	Margin, dB	Antenna gain, dBi	EIRP, dBm	EIRP limit, dBm	Margin, dB
802.11a	149	5745	10.17	8.96	27.00	16.83	9.00	19.17	36.00	16.83
	157	5785	14.46	13.80	27.00	12.54	9.00	23.46	36.00	12.54
	165	5825	11.44	10.67	27.00	15.56	9.00	20.44	36.00	15.56
802.11n HT20	149	5745	10.32	8.92	27.00	16.68	9.00	19.32	36.00	16.68
	157	5785	14.30	13.39	27.00	12.70	9.00	23.30	36.00	12.70
	165	5825	11.42	10.65	27.00	15.58	9.00	20.42	36.00	15.58
802.11n HT40	151	5755	10.10	8.97	27.00	16.90	9.00	19.10	36.00	16.90
	159	5795	12.09	11.30	27.00	14.91	9.00	21.09	36.00	14.91

Table 8.7-4: Output power measurements results as per FCC for 8 dBi (3.6 dBi with cable loss) antenna gain.

Modulation	Channel	Frequency, MHz	Conducted output power at ch0, dBm	Conducted output power at ch1, dBm	Power limit, dBm	Margin, dB	Antenna gain, dBi	EIRP, dBm	EIRP limit, dBm	Margin, dB
802.11a	149	5745	10.17	8.96	30.00	19.83	3.60	13.77	36.00	22.23
	157	5785	14.46	13.80	30.00	15.54	3.60	18.06	36.00	17.94
	165	5825	11.44	10.67	30.00	18.56	3.60	15.04	36.00	20.96
802.11n HT20	149	5745	10.32	8.92	30.00	19.68	3.60	13.92	36.00	22.08
	157	5785	14.30	13.39	30.00	15.70	3.60	17.90	36.00	18.10
	165	5825	11.42	10.65	30.00	18.58	3.60	15.02	36.00	20.98
802.11n HT40	151	5755	10.10	8.97	30.00	19.90	3.60	13.70	36.00	22.30
	159	5795	12.09	11.30	30.00	17.91	3.60	15.69	36.00	20.31

Table 8.7-5: Output power measurements results as per FCC for 7 dBi (2.6 dBi with cable loss) antenna gain.

Modulation	Channel	Frequency, MHz	Conducted output power at ch0, dBm	Conducted output power at ch1, dBm	Power limit, dBm	Margin, dB	Antenna gain, dBi	EIRP, dBm	EIRP limit, dBm	Margin, dB
802.11a	149	5745	10.17	8.96	30.00	19.83	2.60	12.77	36.00	23.23
	157	5785	14.46	13.80	30.00	15.54	2.60	17.06	36.00	18.94
	165	5825	11.44	10.67	30.00	18.56	2.60	14.04	36.00	21.96
802.11n HT20	149	5745	10.32	8.92	30.00	19.68	2.60	12.92	36.00	23.08
	157	5785	14.30	13.39	30.00	15.70	2.60	16.90	36.00	19.10
	165	5825	11.42	10.65	30.00	18.58	2.60	14.02	36.00	21.98
802.11n HT40	151	5755	10.10	8.97	30.00	19.90	2.60	12.70	36.00	23.30
	159	5795	12.09	11.30	30.00	17.91	2.60	14.69	36.00	21.31

Section 8

Testing data

Test name

FCC 15.407(a)(3) and RSS-247 6.2.4(1) 5.725–5.850 GHz band output power and spectral density limits

Specification

FCC Part 15 Subpart E and RSS-247, Issue 1



Table 8.7-6: Output power measurements results as per FCC for 6 dBi antenna gain.

Modulation	Channel	Frequency, MHz	Conducted output power at ch0, dBm	Conducted output power at ch1, dBm	Power limit, dBm	Margin, dB	Antenna gain, dBi	EIRP, dBm	EIRP limit, dBm	Margin, dB
802.11a	149	5745	10.17	8.96	30.00	19.83	6.00	16.17	36.00	19.83
	157	5785	14.46	13.80	30.00	15.54	6.00	20.46	36.00	15.54
	165	5825	11.44	10.67	30.00	18.56	6.00	17.44	36.00	18.56
802.11n HT20	149	5745	10.32	8.92	30.00	19.68	6.00	16.32	36.00	19.68
	157	5785	14.30	13.39	30.00	15.70	6.00	20.30	36.00	15.70
	165	5825	11.42	10.65	30.00	18.58	6.00	17.42	36.00	18.58
802.11n HT40	151	5755	10.10	8.97	30.00	19.90	6.00	16.10	36.00	19.90
	159	5795	12.09	11.30	30.00	17.91	6.00	18.09	36.00	17.91

Table 8.7-7: Output power measurements results as per FCC for 5 dBi antenna gain.

Modulation	Channel	Frequency, MHz	Conducted output power at ch0, dBm	Conducted output power at ch1, dBm	Power limit, dBm	Margin, dB	Antenna gain, dBi	EIRP, dBm	EIRP limit, dBm	Margin, dB
802.11a	149	5745	10.17	8.96	30.00	19.83	5.00	15.17	36.00	20.83
	157	5785	14.46	13.80	30.00	15.54	5.00	19.46	36.00	16.54
	165	5825	11.44	10.67	30.00	18.56	5.00	16.44	36.00	19.56
802.11n HT20	149	5745	10.32	8.92	30.00	19.68	5.00	15.32	36.00	20.68
	157	5785	14.30	13.39	30.00	15.70	5.00	19.30	36.00	16.70
	165	5825	11.42	10.65	30.00	18.58	5.00	16.42	36.00	19.58
802.11n HT40	151	5755	10.10	8.97	30.00	19.90	5.00	15.10	36.00	20.90
	159	5795	12.09	11.30	30.00	17.91	5.00	17.09	36.00	18.91

Table 8.7-8: Output power measurements results as per FCC for 2.5 dBi antenna gain.

Modulation	Channel	Frequency, MHz	Conducted output power at ch0, dBm	Conducted output power at ch1, dBm	Power limit, dBm	Margin, dB	Antenna gain, dBi	EIRP, dBm	EIRP limit, dBm	Margin, dB
802.11a	149	5745	10.17	8.96	30.00	19.83	2.50	12.67	36.00	23.33
	157	5785	14.46	13.80	30.00	15.54	2.50	16.96	36.00	19.04
	165	5825	11.44	10.67	30.00	18.56	2.50	13.94	36.00	22.06
802.11n HT20	149	5745	10.32	8.92	30.00	19.68	2.50	12.82	36.00	23.18
	157	5785	14.30	13.39	30.00	15.70	2.50	16.80	36.00	19.20
	165	5825	11.42	10.65	30.00	18.58	2.50	13.92	36.00	22.08
802.11n HT40	151	5755	10.10	8.97	30.00	19.90	2.50	12.60	36.00	23.40
	159	5795	12.09	11.30	30.00	17.91	2.50	14.59	36.00	21.41

Table 8.7-9: PSD measurements results as per FCC for 9.2 dBi antenna gain.

Modulation	Channel	Frequency, MHz	Conducted PSD at ch0, dBm/0.5 MHz	Conducted PSD at ch1, dBm/0.5 MHz	PSD limit, dBm/0.5 MHz	Margin, dB
802.11a	149	5745	-3.03	-4.33	26.80	29.83
	157	5785	1.35	0.53	26.80	25.45
	165	5825	-1.64	-2.16	26.80	28.44
802.11n HT20	149	5745	-2.87	-4.26	26.80	29.67
	157	5785	0.89	0.12	26.80	25.91
	165	5825	-1.99	-2.65	26.80	28.79
802.11n HT40	151	5755	-6.12	-7.08	26.80	32.92
	159	5795	-4.53	-4.79	26.80	31.33

Section 8

Testing data

Test name

FCC 15.407(a)(3) and RSS-247 6.2.4(1) 5.725–5.850 GHz band output power and spectral density limits

Specification

FCC Part 15 Subpart E and RSS-247, Issue 1



Table 8.7-10: PSD measurements results as per FCC for 9.1 dBi antenna gain.

Modulation	Channel	Frequency, MHz	Conducted PSD at ch0, dBm/0.5 MHz	Conducted PSD at ch1, dBm/0.5 MHz	PSD limit, dBm/0.5 MHz	Margin, dB
802.11a	149	5745	-3.03	-4.33	26.90	29.93
	157	5785	1.35	0.53	26.90	25.55
	165	5825	-1.64	-2.16	26.90	28.54
802.11n HT20	149	5745	-2.87	-4.26	26.90	29.77
	157	5785	0.89	0.12	26.90	26.01
	165	5825	-1.99	-2.65	26.90	28.89
802.11n HT40	151	5755	-6.12	-7.08	26.90	33.02
	159	5795	-4.53	-4.79	26.90	31.43

Table 8.7-11: PSD measurements results as per FCC for 9 dBi antenna gain.

Modulation	Channel	Frequency, MHz	Conducted PSD at ch0, dBm/0.5 MHz	Conducted PSD at ch1, dBm/0.5 MHz	PSD limit, dBm/0.5 MHz	Margin, dB
802.11a	149	5745	-3.03	-4.33	27.00	30.03
	157	5785	1.35	0.53	27.00	25.65
	165	5825	-1.64	-2.16	27.00	28.64
802.11n HT20	149	5745	-2.87	-4.26	27.00	29.87
	157	5785	0.89	0.12	27.00	26.11
	165	5825	-1.99	-2.65	27.00	28.99
802.11n HT40	151	5755	-6.12	-7.08	27.00	33.12
	159	5795	-4.53	-4.79	27.00	31.53

Table 8.7-12: PSD measurements results as per FCC for 6 dBi, 5 dBi, 2.5 dBi, 8 dBi (3.6 dBi with cable loss), and 7 dBi (2.6 dBi with cable loss) antenna gains.

Modulation	Channel	Frequency, MHz	Conducted PSD at ch0, dBm/0.5 MHz	Conducted PSD at ch1, dBm/0.5 MHz	PSD limit, dBm/0.5 MHz	Margin, dB
802.11a	149	5745	-3.03	-4.33	30.00	33.03
	157	5785	1.35	0.53	30.00	28.65
	165	5825	-1.64	-2.16	30.00	31.64
802.11n HT20	149	5745	-2.87	-4.26	30.00	32.87
	157	5785	0.89	0.12	30.00	29.11
	165	5825	-1.99	-2.65	30.00	31.99
802.11n HT40	151	5755	-6.12	-7.08	30.00	36.12
	159	5795	-4.53	-4.79	30.00	34.53

Table 8.7-13: Output power measurements results as per ISSED for 6 dBi antenna gain.

Modulation	Channel	Frequency, MHz	Conducted output power at ch0, dBm	Conducted output power at ch1, dBm	Power limit, dBm	Margin, dB	Antenna gain, dBi	EIRP, dBm	EIRP limit, dBm	Margin, dB
802.11a	149	5745	10.17	8.96	30.00	19.83	6.00	16.17	36.00	19.83
	157	5785	14.46	13.80	30.00	15.54	6.00	20.46	36.00	15.54
	165	5825	11.44	10.67	30.00	18.56	6.00	17.44	36.00	18.56
802.11n HT20	149	5745	10.32	8.92	30.00	19.68	6.00	16.32	36.00	19.68
	157	5785	14.30	13.39	30.00	15.70	6.00	20.30	36.00	15.70
	165	5825	11.42	10.65	30.00	18.58	6.00	17.42	36.00	18.58
802.11n HT40	151	5755	10.10	8.97	30.00	19.90	6.00	16.10	36.00	19.90
	159	5795	12.09	11.30	30.00	17.91	6.00	18.09	36.00	17.91

Section 8

Testing data

Test name

FCC 15.407(a)(3) and RSS-247 6.2.4(1) 5.725–5.850 GHz band output power and spectral density limits

Specification

FCC Part 15 Subpart E and RSS-247, Issue 1



Table 8.7-14: Output power measurements results as per ISED for 5 dBi antenna gain.

Modulation	Channel	Frequency, MHz	Conducted output power at ch0, dBm	Conducted output power at ch1, dBm	Power limit, dBm	Margin, dB	Antenna gain, dBi	EIRP, dBm	EIRP limit, dBm	Margin, dB
802.11a	149	5745	10.17	8.96	30.00	19.83	5.00	15.17	36.00	20.83
	157	5785	14.46	13.80	30.00	15.54	5.00	19.46	36.00	16.54
	165	5825	11.44	10.67	30.00	18.56	5.00	16.44	36.00	19.56
802.11n HT20	149	5745	10.32	8.92	30.00	19.68	5.00	15.32	36.00	20.68
	157	5785	14.30	13.39	30.00	15.70	5.00	19.30	36.00	16.70
802.11n HT40	165	5825	11.42	10.65	30.00	18.58	5.00	16.42	36.00	19.58
	151	5755	10.10	8.97	30.00	19.90	5.00	15.10	36.00	20.90
	159	5795	12.09	11.30	30.00	17.91	5.00	17.09	36.00	18.91

Table 8.7-15: Output power measurements results as per ISED for 2.5 dBi antenna gain.

Modulation	Channel	Frequency, MHz	Conducted output power at ch0, dBm	Conducted output power at ch1, dBm	Power limit, dBm	Margin, dB	Antenna gain, dBi	EIRP, dBm	EIRP limit, dBm	Margin, dB
802.11a	149	5745	10.17	8.96	30.00	19.83	2.50	12.67	36.00	23.33
	157	5785	14.46	13.80	30.00	15.54	2.50	16.96	36.00	19.04
	165	5825	11.44	10.67	30.00	18.56	2.50	13.94	36.00	22.06
802.11n HT20	149	5745	10.32	8.92	30.00	19.68	2.50	12.82	36.00	23.18
	157	5785	14.30	13.39	30.00	15.70	2.50	16.80	36.00	19.20
802.11n HT40	165	5825	11.42	10.65	30.00	18.58	2.50	13.92	36.00	22.08
	151	5755	10.10	8.97	30.00	19.90	2.50	12.60	36.00	23.40
	159	5795	12.09	11.30	30.00	17.91	2.50	14.59	36.00	21.41

Table 8.7-16: PSD measurements results as per ISED for 6, 5 and 2.5 dBi antenna gains.

Modulation	Channel	Frequency, MHz	Conducted PSD at ch0, dBm/0.5 MHz	Conducted PSD at ch1, dBm/0.5 MHz	PSD limit, dBm/0.5 MHz	Margin, dB
802.11a	149	5745	-3.03	-4.33	30.00	33.03
	157	5785	1.35	0.53	30.00	28.65
	165	5825	-1.64	-2.16	30.00	31.64
802.11n HT20	149	5745	-2.87	-4.26	30.00	32.87
	157	5785	0.89	0.12	30.00	29.11
802.11n HT40	165	5825	-1.99	-2.65	30.00	31.99
	151	5755	-6.12	-7.08	30.00	36.12
	159	5795	-4.53	-4.79	30.00	34.53

Section 8

Testing data

Test name

FCC 15.407(a)(3) and RSS-247 6.2.4(1) 5.725–5.850 GHz band output power and spectral density limits

Specification

FCC Part 15 Subpart E and RSS-247, Issue 1

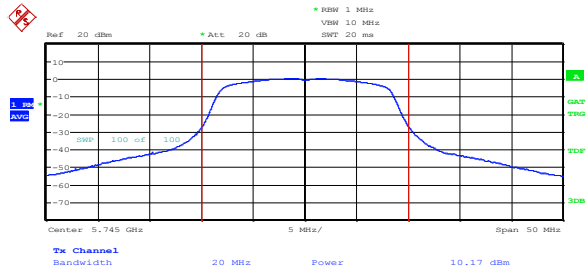

Date: 14.DEC.2016 16:31:33

Figure 8.7-1: Sample plot for power on 802.11a

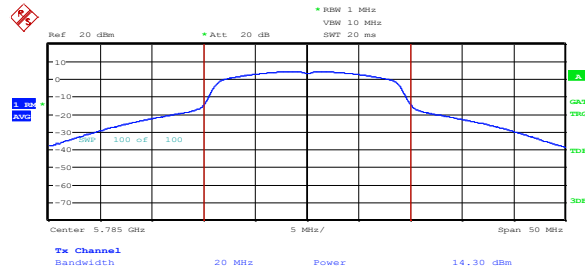

Date: 14.DEC.2016 16:28:13

Figure 8.7-2: Sample plot for power on 802.11n HT20

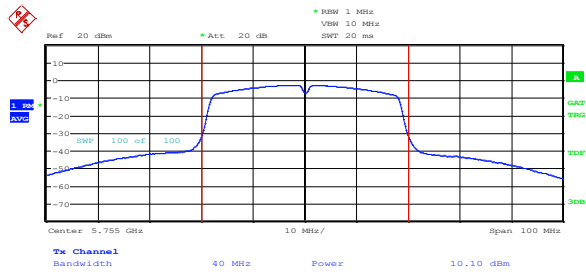

Date: 14.DEC.2016 16:32:35

Figure 8.7-3: Sample plot for power on 802.11n HT40

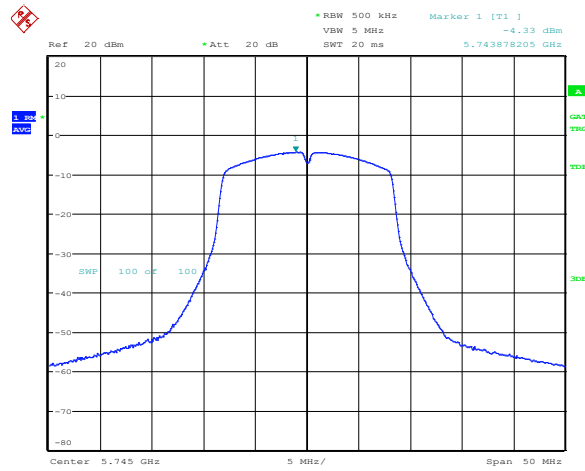

Date: 14.DEC.2016 16:10:25

Figure 8.7-4: Sample plot for PSD on 802.11n HT20

Section 8

Testing data

Test name

FCC 15.407(a)(3) and RSS-247 6.2.4(1) 5.725–5.850 GHz band output power and spectral density limits

Specification

FCC Part 15 Subpart E and RSS-247, Issue 1

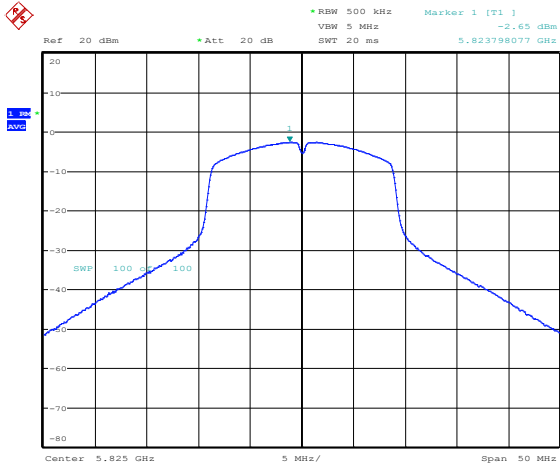

Date: 14.DEC.2016 16:01:54

Figure 8.7-5: Sample plot for PSD on 802.11 n HT20

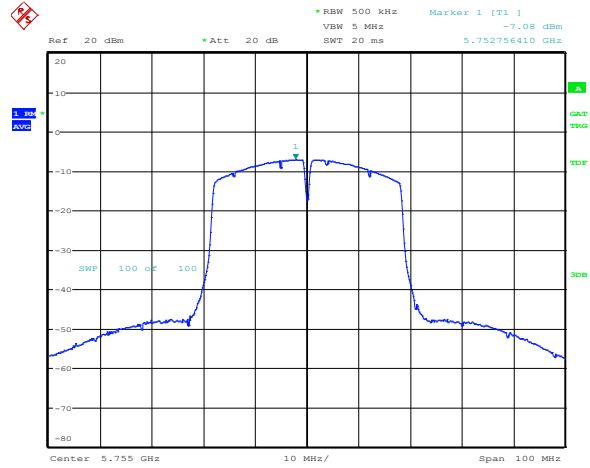

Date: 14.DEC.2016 16:13:48

Figure 8.7-6: Sample plot for PSD on 802.11n HT40

8.8 FCC 15.407(b) and RSS-247 6.2 Undesirable (unwanted) emissions

8.8.1 Definitions and limits

FCC:

- (1) For transmitters operating in the 5.15-5.25 GHz band: All emissions outside of the 5.15–5.35 GHz band shall not exceed an e.i.r.p. of –27 dBm/MHz.
- (2) For transmitters operating in the 5.25-5.35 GHz band: All emissions outside of the 5.15–5.35 GHz band shall not exceed an e.i.r.p. of –27 dBm/MHz.
- (3) For transmitters operating in the 5.47-5.725 GHz band: All emissions outside of the 5.47–5.725 GHz band shall not exceed an e.i.r.p. of –27 dBm/MHz.
- (4) For transmitters operating in the 5.725–5.850 GHz band:
 - (i) All emissions shall be limited to a level of –27 dBm/MHz at 75 MHz or more above or below the band edge increasing linearly to 10 dBm/MHz at 25 MHz above or below the band edge, and from 25 MHz above or below the band edge increasing linearly to a level of 15.6 dBm/MHz at 5 MHz above or below the band edge, and from 5 MHz above or below the band edge increasing linearly to a level of 27 dBm/MHz at the band edge.
 - (5) The emission measurements shall be performed using a minimum resolution bandwidth of 1 MHz. A lower resolution bandwidth may be employed near the band edge, when necessary, provided the measured energy is integrated to show the total power over 1 MHz.
 - (6) Unwanted emissions below 1 GHz must comply with the general field strength limits set forth in § 15.209.
 - (7) The provisions of § 15.205 apply to intentional radiators operating under this section.
 - (8) When measuring the emission limits, the nominal carrier frequency shall be adjusted as close to the upper and lower frequency block edges as the design of the equipment permits.

ISED:

- 6.2.1 (2) For transmitters operating in the band 5150–5250 MHz, all emissions outside the band 5150–5350 MHz shall not exceed –27 dBm/MHz e.i.r.p. However, any unwanted emissions that fall into the band 5250–5350 MHz must be 26 dBc, when measured using a resolution bandwidth between 1 and 5% of the occupied bandwidth, above 5.25 GHz. Otherwise, the transmission is considered as intentional and the devices shall implement dynamic frequency selection (DFS) and transmitter power control (TPC) as per the requirements for the band 5250–5350 MHz.
- 6.2.2 (2) i) For devices with both operating frequencies and channel bandwidths contained within the band 5250-5350 MHz, the device shall comply with the following:
- a) All emissions outside the band 5250–5350 MHz shall not exceed –27 dBm/MHz e.i.r.p. if the equipment is intended for outdoor use; or
 - b) All emissions outside the band 5150–5350 MHz shall not exceed –27 dBm/MHz e.i.r.p. and any emissions within the band 5150–5250 MHz shall meet the power spectral density limits of Section 6.2.1. The device shall be labelled “for indoor use only.”
- ii) For devices with operating frequencies in the band 5250–5350 MHz but having a channel bandwidth that overlaps the band 5150–5250 MHz, the devices’ unwanted emission shall not exceed –27 dBm/MHz e.i.r.p. outside the band 5150–5350 MHz and its power shall comply with the spectral power density for operation within the band 5150–5250 MHz. The device shall be labelled “for indoor use only.”
- 6.2.3 (2) Emissions outside the band 5470–5725 MHz shall not exceed –27 dBm/MHz e.i.r.p.
- 6.2.4 (2) For the band 5725–5850 MHz, emissions at frequencies from the band edges to 10 MHz above or below the band edges shall not exceed –17 dBm/MHz e.i.r.p.
For emissions at frequencies more than 10 MHz above or below the band edges, the emissions power shall not exceed –27 dBm/MHz.

RSS-Gen 8.10 Emissions falling within restricted frequency bands

Restricted bands, identified in Table 8.8-2, are designated primarily for safety-of-life services (distress calling and certain aeronautical bands), certain satellite downlinks, radio astronomy and some government uses. Except where otherwise indicated, the following restrictions apply:

- (a) fundamental components of modulation of licence-exempt radio apparatus shall not fall within the restricted bands of below;
- (b) unwanted emissions falling into restricted bands of below shall comply with the limits specified in RSS-Gen;
- (c) unwanted emissions not falling within restricted frequency bands shall either comply with the limits specified in the applicable RSS, or with those specified in RSS-Gen.



Table 8.8-1: FCC §15.209 and RSS-Gen – Radiated emission limits

Frequency, MHz	Field strength of emissions		Measurement distance, m
	µV/m	dBµV/m	
0.009–0.490	2400/F (F in kHz)	67.6 – 20 × log ₁₀ (F) (F in kHz)	300
0.490–1.705	24000/F (F in kHz)	87.6 – 20 × log ₁₀ (F) (F in kHz)	30
1.705–30.0	30	29.5	30
30–88	100	40.0	3
88–216	150	43.5	3
216–960	200	46.0	3
above 960	500	54.0	3

Notes: In the emission table above, the tighter limit applies at the band edges.
 For frequencies above 1 GHz the limit on peak RF emissions is 20 dB above the maximum permitted average emission limit applicable to the equipment under test

8.8.1 Definitions and limits, continued

Table 8.8-2: IC restricted frequency bands

MHz	MHz	MHz	GHz
0.090–0.110	12.51975–12.52025	399.9–410	5.35–5.46
2.1735–2.1905	12.57675–12.57725	608–614	7.25–7.75
3.020–3.026	13.36–13.41	960–1427	8.025–8.5
4.125–4.128	16.42–16.423	1435–1626.5	9.0–9.2
4.17725–4.17775	16.69475–16.69525	1645.5–1646.5	9.3–9.5
4.20725–4.20775	16.80425–16.80475	1660–1710	10.6–12.7
5.677–5.683	25.5–25.67	1718.8–1722.2	13.25–13.4
6.215–6.218	37.5–38.25	2200–2300	14.47–14.5
6.26775–6.26825	73–74.6	2310–2390	15.35–16.2
6.31175–6.31225	74.8–75.2	2655–2900	17.7–21.4
8.291–8.294	108–138	3260–3267	22.01–23.12
8.362–8.366	156.52475–156.52525	3332–3339	23.6–24.0
8.37625–8.38675	156.7–156.9	3345.8–3358	31.2–31.8
8.41425–8.41475	240–285	3500–4400	36.43–36.5
12.29–12.293	322–335.4	4500–5150	Above 38.6

Note: Certain frequency bands listed in Table 8.8-2 and above 38.6 GHz are designated for low-power license-exempt applications. These frequency bands and the requirements that apply to the devices are set out in this Standard

Table 8.8-3: FCC restricted frequency bands

MHz	MHz	MHz	GHz
0.090–0.110	16.42–16.423	399.9–410	4.5–5.15
0.495–0.505	16.69475–16.69525	608–614	5.35–5.46
2.1735–2.1905	16.80425–16.80475	960–1240	7.25–7.75
4.125–4.128	25.5–25.67	1300–1427	8.025–8.5
4.17725–4.17775	37.5–38.25	1435–1626.5	9.0–9.2
4.20725–4.20775	73–74.6	1645.5–1646.5	9.3–9.5
6.215–6.218	74.8–75.2	1660–1710	10.6–12.7
6.26775–6.26825	108–121.94	1718.8–1722.2	13.25–13.4
6.31175–6.31225	123–138	2200–2300	14.47–14.5
8.291–8.294	149.9–150.05	2310–2390	15.35–16.2
8.362–8.366	156.52475–156.52525	2483.5–2500	17.7–21.4
8.37625–8.38675	156.7–156.9	2690–2900	22.01–23.12
8.41425–8.41475	162.0125–167.17	3260–3267	23.6–24.0
12.29–12.293	167.72–173.2	3332–3339	31.2–31.8
12.51975–12.52025	240–285	3345.8–3358	36.43–36.5
12.57675–12.57725	322–335.4	3600–4400	Above 38.6
13.36–13.41			

8.8.2 Test summary

Begin test date:	December 6, 2016	Temperature:	24 °C
Test engineer:	Andrey Adelberg	Air pressure:	1015 mbar
Verdict:	Pass	Relative humidity:	42 %

8.8.3 Observations, settings and special notes

The spectrum was searched from 30 MHz to 40 GHz.

Radiated measurements were performed at a distance of 3 m. Radiated emissions were performed while both antenna connectors were terminated with 50 Ω load.

Spectrum analyser for peak conducted measurements within restricted bands below 1 GHz:

Resolution bandwidth:	100 kHz
Video bandwidth:	300 kHz
Detector mode:	Peak
Trace mode:	Max Hold

Limit line was set as follows: $54 \text{ dB}\mu\text{V/m} - 95.23 \text{ dB} - 4.7 \text{ dB} = -45.93 \text{ dBm}$

Spectrum analyser for peak conducted measurements within restricted bands above 1 GHz:

Resolution bandwidth:	1 MHz
Video bandwidth:	3 MHz
Detector mode:	Peak
Trace mode:	Max Hold

Average limit line was set as follows: $54 \text{ dB}\mu\text{V/m} - 95.23 \text{ dB} = -41.23 \text{ dBm/MHz}$

Spectrum analyser for average conducted measurements within restricted bands above 1 GHz for frequencies where peak results were above the average limit:

Resolution bandwidth:	1 MHz
Video bandwidth:	10 MHz
Detector mode:	RMS
Trace mode:	Power average
Number of averaging traces:	100

Peak limit is 20 dB higher than the average limit: $-41.23 \text{ dBm/MHz} + 20 \text{ dB} = -21.23 \text{ dBm/MHz}$

Spectrum analyser for peak conducted measurements outside restricted bands:

Resolution bandwidth:	1 MHz
Video bandwidth:	3 MHz
Detector mode:	Peak
Trace mode:	Max Hold

Each plot provided below has a reference level offset set to compensate for the maximum antenna gain of (9.2 dBi).

Since EUT **cannot** transmit simultaneously from both antenna chains, there is no need to compensate for multiple antenna ports.

8.8.4 Test data

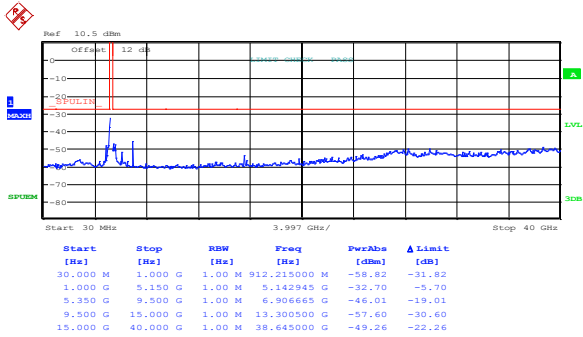

Date: 13.DEC.2016 10:42:05

Figure 8.8-1: Spurious emissions outside restricted bands at channel 36, 802.11a, cho

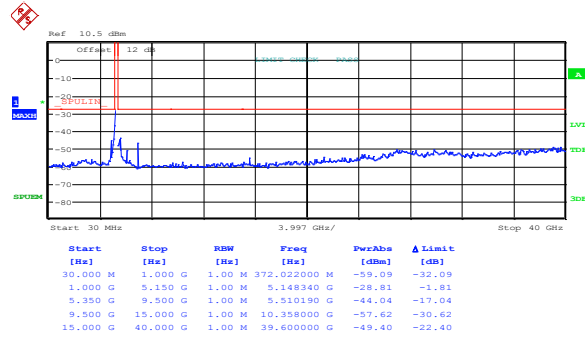

Date: 12.DEC.2016 11:13:26

Figure 8.8-2: Spurious emissions outside restricted bands at channel 36, 802.11n HT20, cho

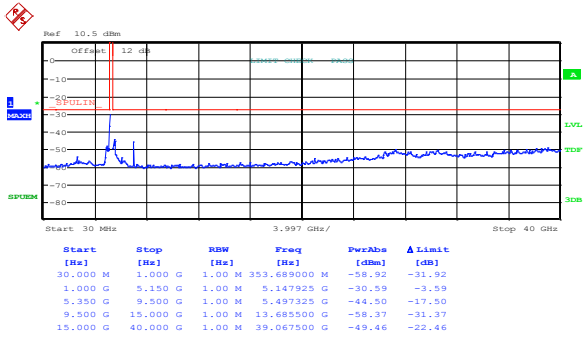

Date: 12.DEC.2016 11:17:38

Figure 8.8-3: Spurious emissions outside restricted bands at channel 38, 802.11n HT40, cho

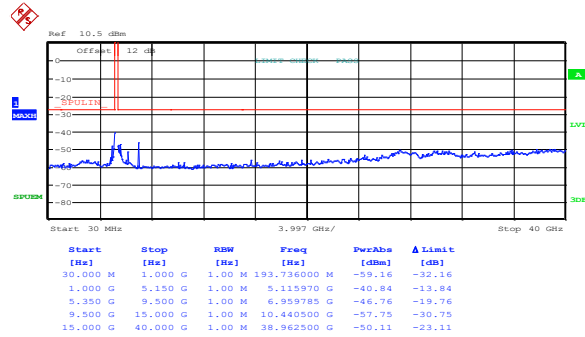

Date: 13.DEC.2016 10:42:58

Figure 8.8-4: Spurious emissions outside restricted bands at channel 44, 802.11a, cho

Section 8
Test name
Specification

Testing data
 FCC 15.407(b) and RSS-247 6.2 Undesirable (unwanted) emissions
 FCC Part 15 Subpart E and RSS-247, Issue 1

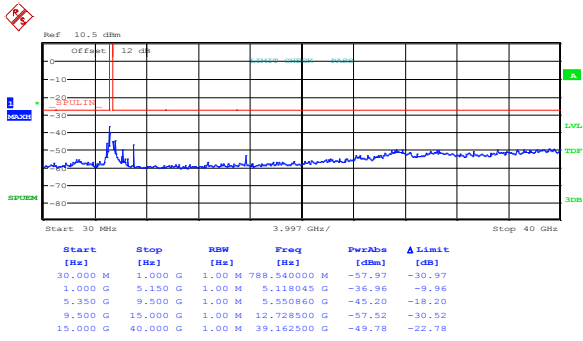

Date: 12.DEC.2016 11:14:25

Figure 8.8-5: Spurious emissions outside restricted bands at channel 44, 802.11n HT20, cho

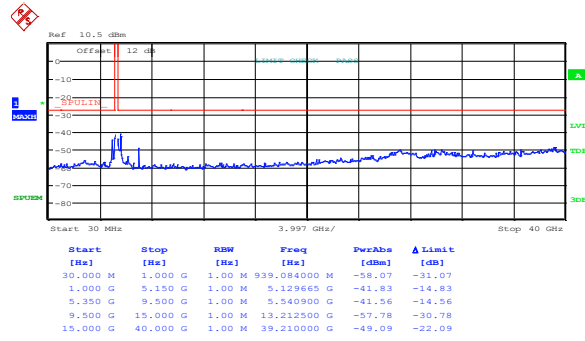

Date: 12.DEC.2016 11:18:20

Figure 8.8-6: Spurious emissions outside restricted bands at channel 46, 802.11n HT40, cho

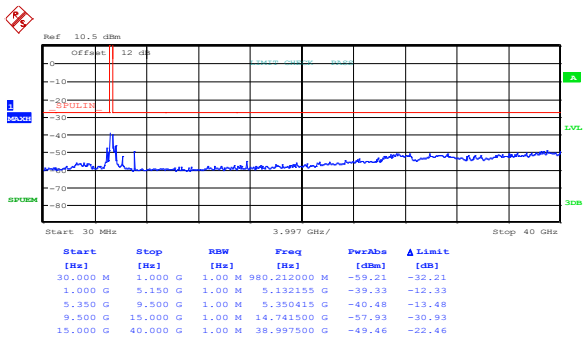

Date: 13.DEC.2016 10:43:34

Figure 8.8-7: Spurious emissions outside restricted bands at channel 48, 802.11a, cho

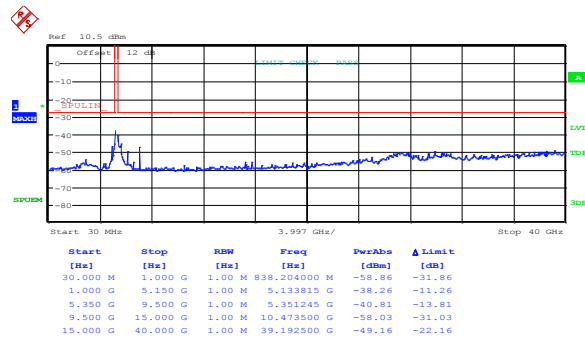

Date: 12.DEC.2016 11:14:56

Figure 8.8-8: Spurious emissions outside restricted bands at channel 48, 802.11n HT20, cho

Section 8
Test name
Specification

Testing data
 FCC 15.407(b) and RSS-247 6.2 Undesirable (unwanted) emissions
 FCC Part 15 Subpart E and RSS-247, Issue 1

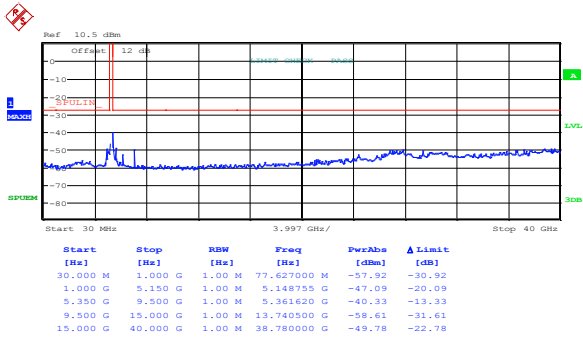

Date: 13.DEC.2016 10:44:09

Figure 8.8-9: Spurious emissions outside restricted bands at channel 52, 802.11a, cho

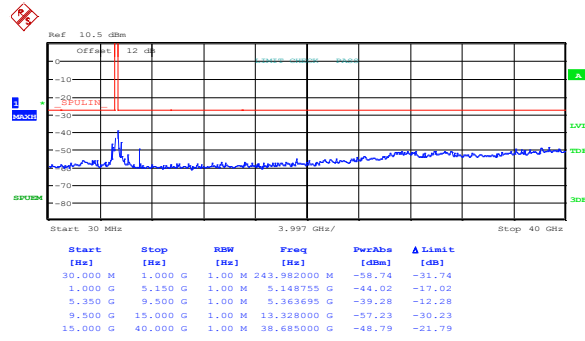

Date: 12.DEC.2016 11:15:39

Figure 8.8-10: Spurious emissions outside restricted bands at channel 52, 802.11n HT20, cho

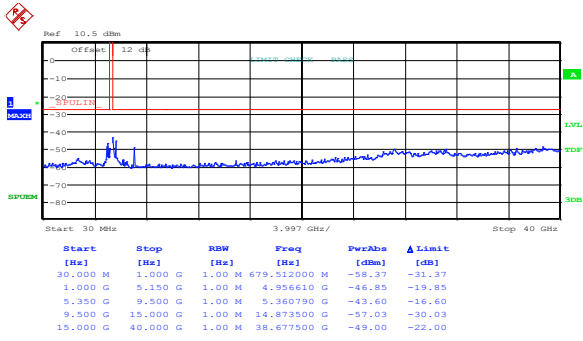

Date: 12.DEC.2016 11:19:05

Figure 8.8-11: Spurious emissions outside restricted bands at channel 54, 802.11n HT40, cho

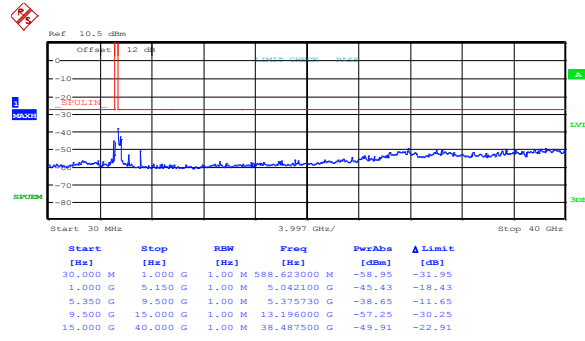

Date: 13.DEC.2016 10:44:43

Figure 8.8-12: Spurious emissions outside restricted bands at channel 60, 802.11a, cho

Section 8
Test name
Specification

Testing data
 FCC 15.407(b) and RSS-247 6.2 Undesirable (unwanted) emissions
 FCC Part 15 Subpart E and RSS-247, Issue 1

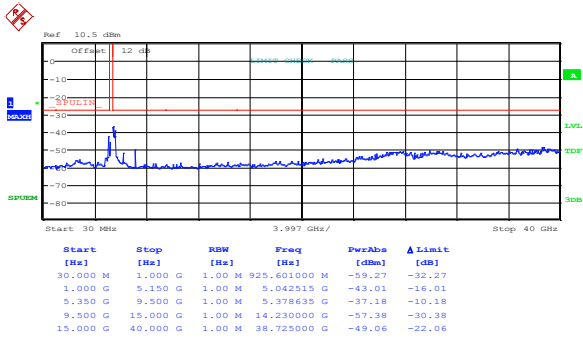

Date: 12.DEC.2016 11:16:13

Figure 8.8-13: Spurious emissions outside restricted bands at channel 60, 802.11n HT20, cho

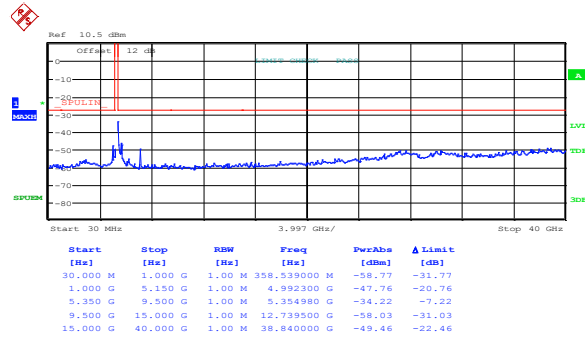

Date: 12.DEC.2016 11:21:24

Figure 8.8-14: Spurious emissions outside restricted bands at channel 62, 802.11n HT40, cho

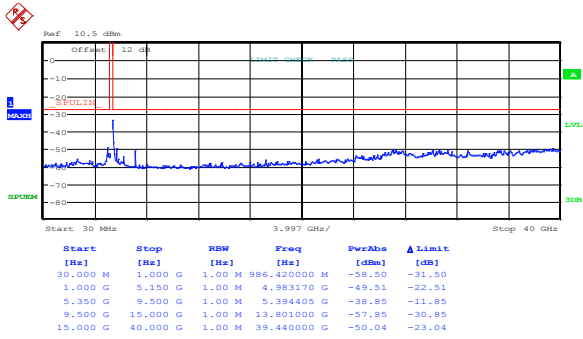

Date: 13.DEC.2016 10:45:16

Figure 8.8-15: Spurious emissions outside restricted bands at channel 64, 802.11a, cho

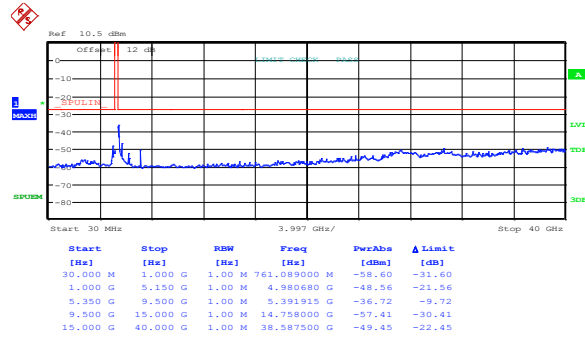

Date: 12.DEC.2016 11:16:43

Figure 8.8-16: Spurious emissions outside restricted bands at channel 64, 802.11n HT20, cho

Section 8
Test name
Specification

Testing data
 FCC 15.407(b) and RSS-247 6.2 Undesirable (unwanted) emissions
 FCC Part 15 Subpart E and RSS-247, Issue 1

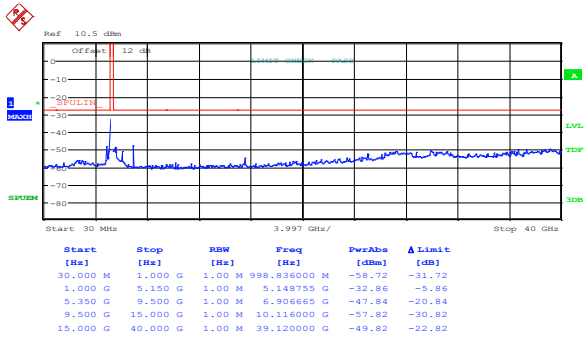

Date: 12.DEC.2016 11:24:28

Figure 8.8-17: Spurious emissions outside restricted bands at channel 36, 802.11a, ch1

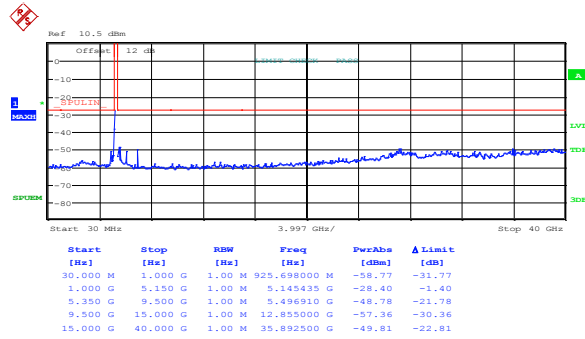

Date: 12.DEC.2016 11:30:05

Figure 8.8-18: Spurious emissions outside restricted bands at channel 36, 802.11n HT20, ch1

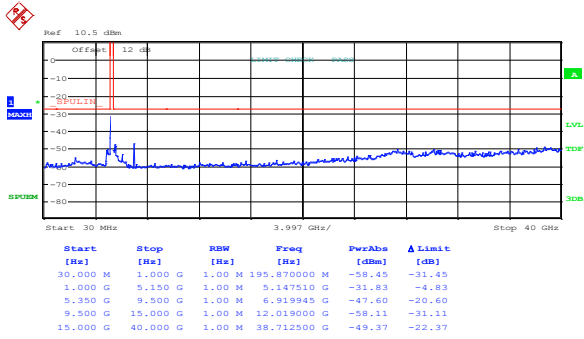

Date: 12.DEC.2016 11:34:31

Figure 8.8-19: Spurious emissions outside restricted bands at channel 38, 802.11n HT40, ch1

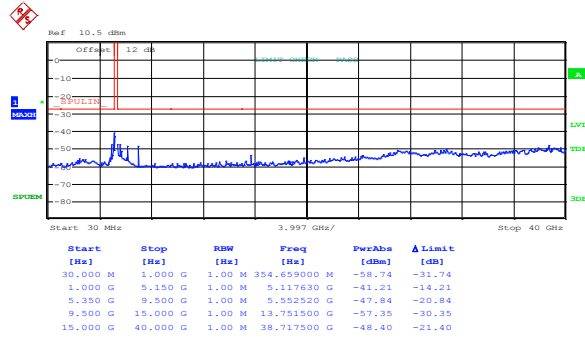

Date: 12.DEC.2016 11:25:12

Figure 8.8-20: Spurious emissions outside restricted bands at channel 44, 802.11a, ch1

Section 8
Test name
Specification

Testing data
 FCC 15.407(b) and RSS-247 6.2 Undesirable (unwanted) emissions
 FCC Part 15 Subpart E and RSS-247, Issue 1

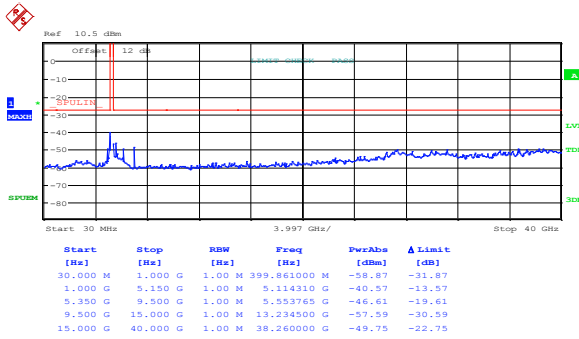

Date: 12.DEC.2016 11:31:00

Figure 8.8-21: Spurious emissions outside restricted bands at channel 44, 802.11n HT20, ch1

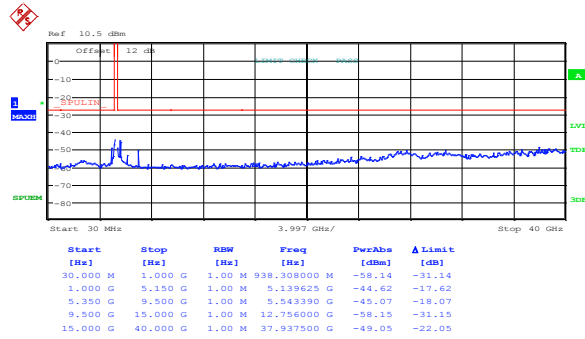

Date: 12.DEC.2016 11:35:09

Figure 8.8-22: Spurious emissions outside restricted bands at channel 46, 802.11n HT40, ch1

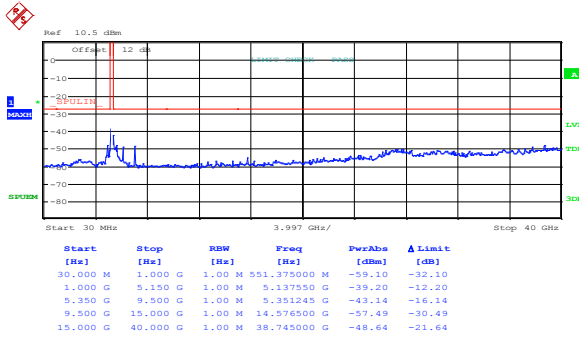

Date: 12.DEC.2016 11:26:02

Figure 8.8-23: Spurious emissions outside restricted bands at channel 48, 802.11a, ch1

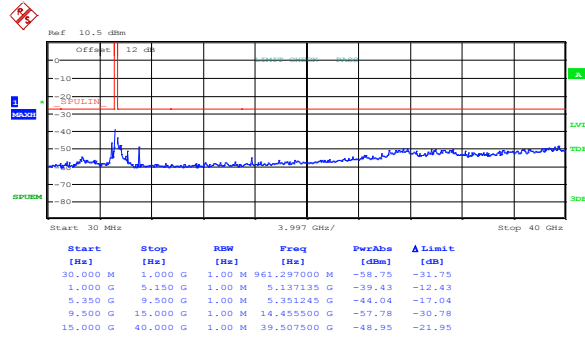

Date: 12.DEC.2016 11:31:36

Figure 8.8-24: Spurious emissions outside restricted bands at channel 48, 802.11n HT20, ch1

Section 8
Test name
Specification

Testing data
 FCC 15.407(b) and RSS-247 6.2 Undesirable (unwanted) emissions
 FCC Part 15 Subpart E and RSS-247, Issue 1

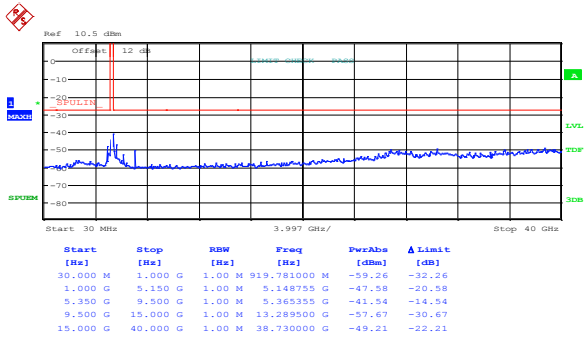

Date: 12.DEC.2016 11:26:37

Figure 8.8-25: Spurious emissions outside restricted bands at channel 52, 802.11a, ch1

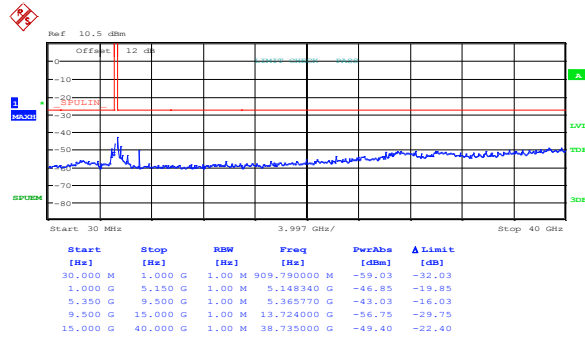

Date: 12.DEC.2016 11:32:38

Figure 8.8-26: Spurious emissions outside restricted bands at channel 52, 802.11n HT20, ch1

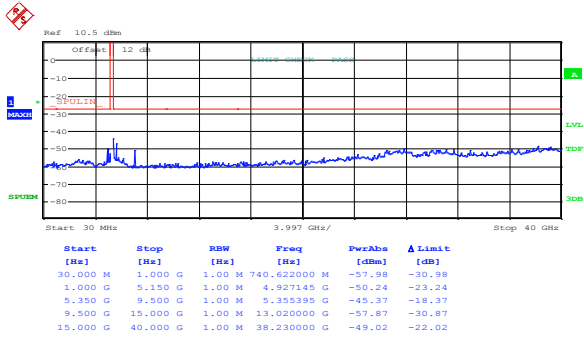

Date: 12.DEC.2016 11:35:44

Figure 8.8-27: Spurious emissions outside restricted bands at channel 54, 802.11n HT40, ch1

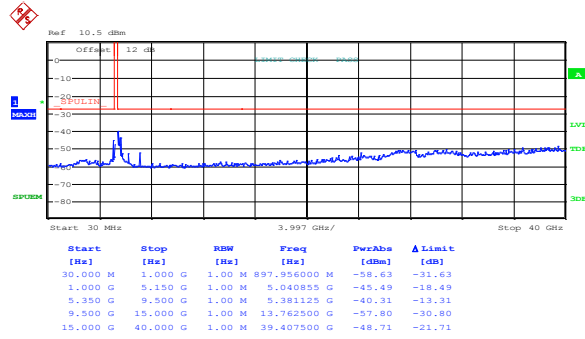

Date: 12.DEC.2016 11:27:08

Figure 8.8-28: Spurious emissions outside restricted bands at channel 60, 802.11a, ch1

Section 8
Test name
Specification

Testing data
 FCC 15.407(b) and RSS-247 6.2 Undesirable (unwanted) emissions
 FCC Part 15 Subpart E and RSS-247, Issue 1

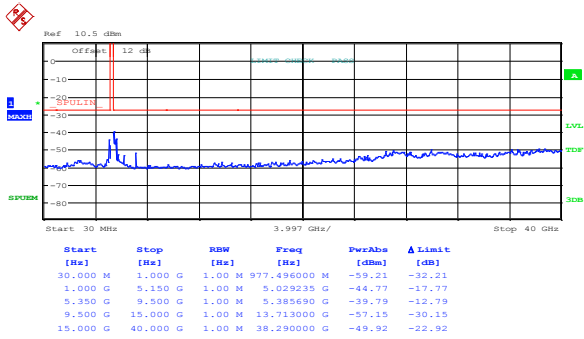

Date: 12.DEC.2016 11:33:11

Figure 8.8-29: Spurious emissions outside restricted bands at channel 60, 802.11n HT20, ch1

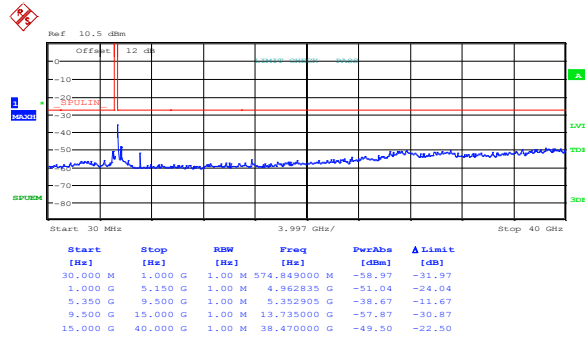

Date: 12.DEC.2016 11:36:15

Figure 8.8-30: Spurious emissions outside restricted bands at channel 62, 802.11n HT40, ch1

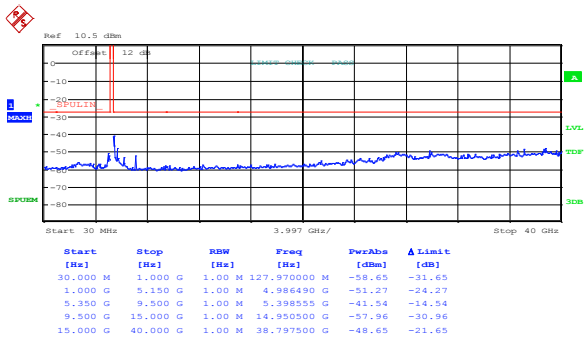

Date: 12.DEC.2016 11:27:40

Figure 8.8-31: Spurious emissions outside restricted bands at channel 64, 802.11n, ch1

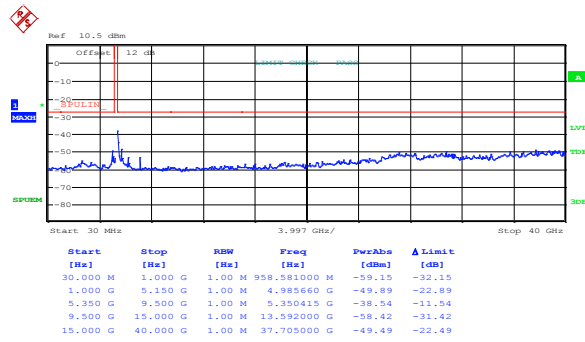

Date: 12.DEC.2016 11:33:42

Figure 8.8-32: Spurious emissions outside restricted bands at channel 64, 802.11n HT20, ch1

Section 8
Test name
Specification

Testing data
 FCC 15.407(b) and RSS-247 6.2 Undesirable (unwanted) emissions
 FCC Part 15 Subpart E and RSS-247, Issue 1

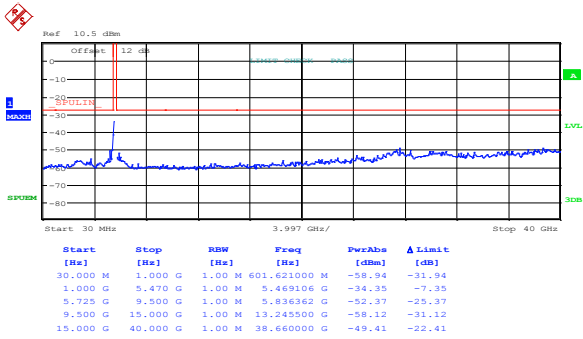

Date: 13.DEC.2016 10:47:59

Figure 8.8-33: Spurious emissions outside restricted bands at channel 100, 802.11a, cho

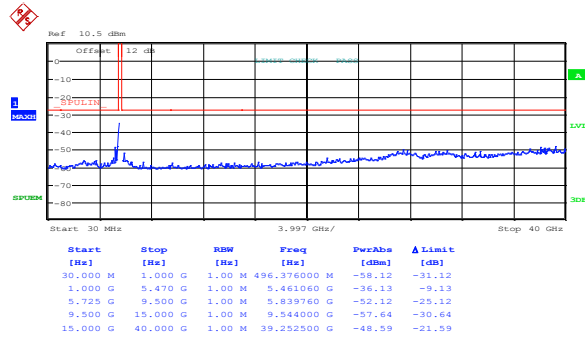

Date: 13.DEC.2016 10:50:43

Figure 8.8-34: Spurious emissions outside restricted bands at channel 100, 802.11n HT20, cho

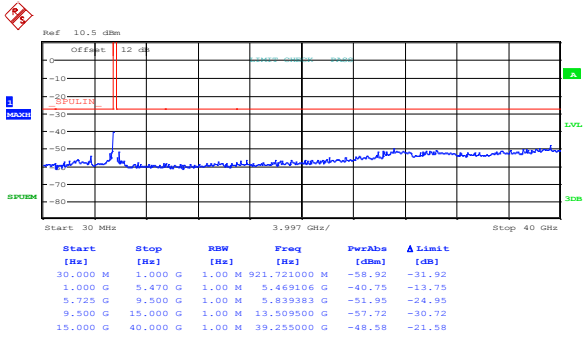

Date: 13.DEC.2016 10:52:54

Figure 8.8-35: Spurious emissions outside restricted bands at channel 102, 802.11n HT40, cho

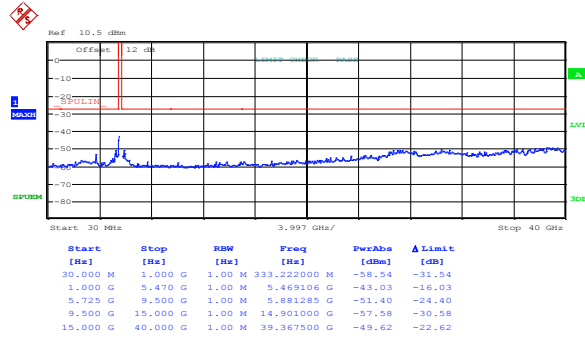

Date: 13.DEC.2016 10:53:33

Figure 8.8-36: Spurious emissions outside restricted bands at channel 110, 802.11n HT40, cho

Section 8
Test name
Specification

Testing data
 FCC 15.407(b) and RSS-247 6.2 Undesirable (unwanted) emissions
 FCC Part 15 Subpart E and RSS-247, Issue 1

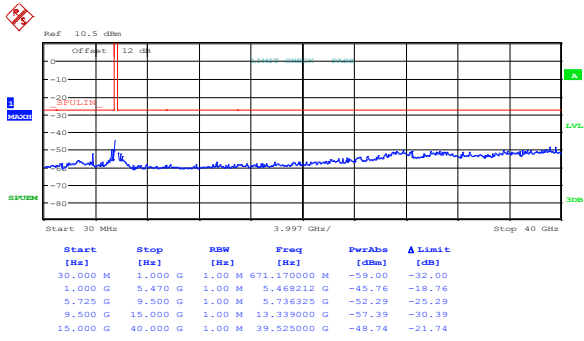

Date: 13.DEC.2016 10:48:38

Figure 8.8-37: Spurious emissions outside restricted bands at channel 116, 802.11a, cho

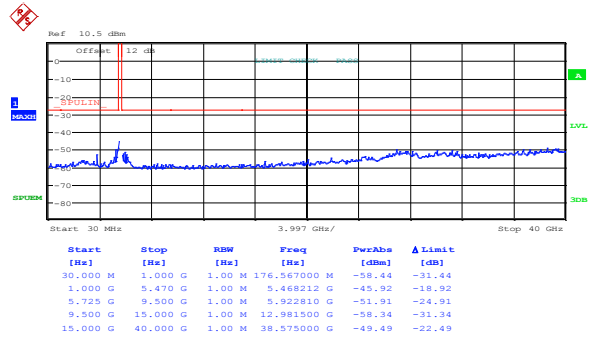

Date: 13.DEC.2016 10:51:15

Figure 8.8-38: Spurious emissions outside restricted bands at channel 116, 802.11n HT20, cho

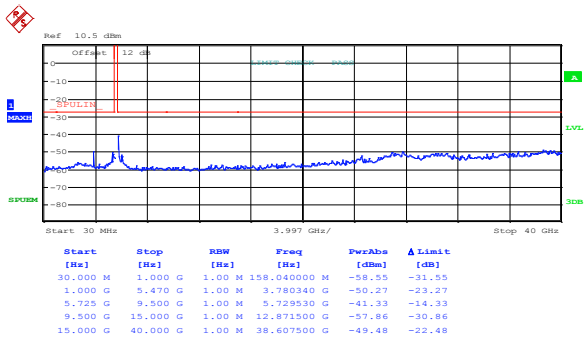

Date: 13.DEC.2016 10:54:28

Figure 8.8-39: Spurious emissions outside restricted bands at channel 134, 802.11n HT40, cho

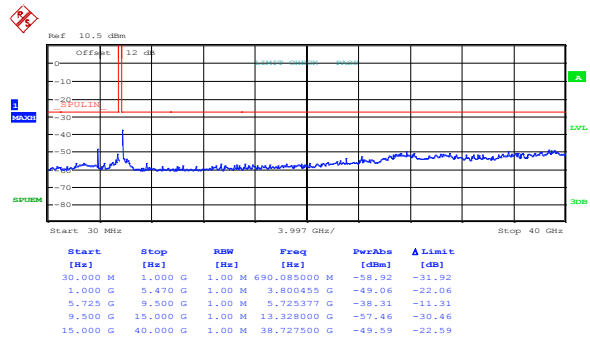

Date: 13.DEC.2016 10:49:11

Figure 8.8-40: Spurious emissions outside restricted bands at channel 140, 802.11a, cho

Section 8
Test name
Specification

Testing data
 FCC 15.407(b) and RSS-247 6.2 Undesirable (unwanted) emissions
 FCC Part 15 Subpart E and RSS-247, Issue 1

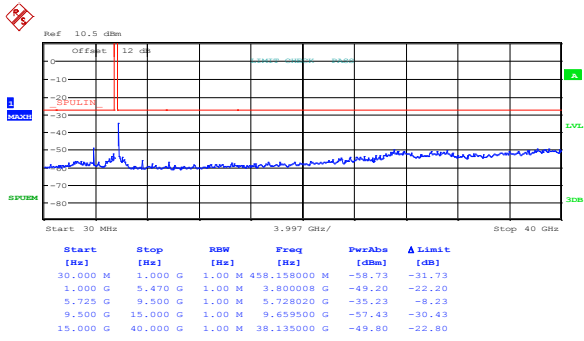

Date: 13.DEC.2016 10:51:47

Figure 8.8-41: Spurious emissions outside restricted bands at channel 140, 802.11n HT20, cho

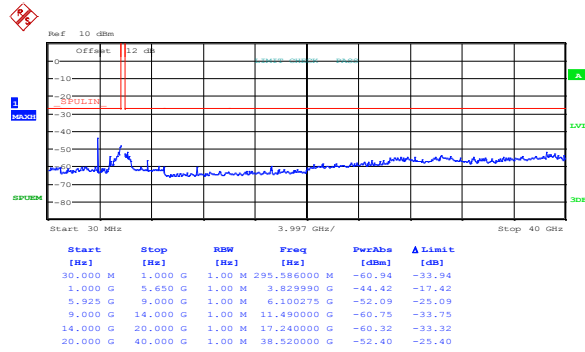

Date: 14.DEC.2016 15:28:21

Figure 8.8-42: Spurious emissions outside restricted bands at channel 149, 802.11a, cho

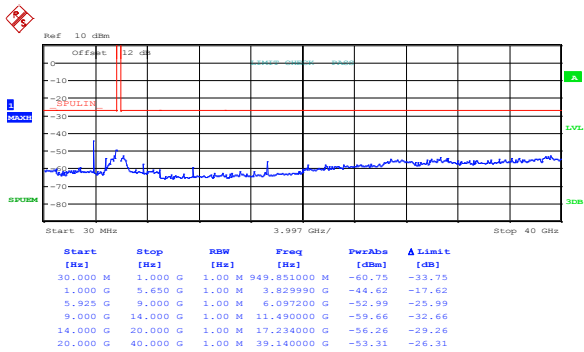

Date: 14.DEC.2016 15:30:20

Figure 8.8-43: Spurious emissions outside restricted bands at channel 149, 802.11n HT20, cho

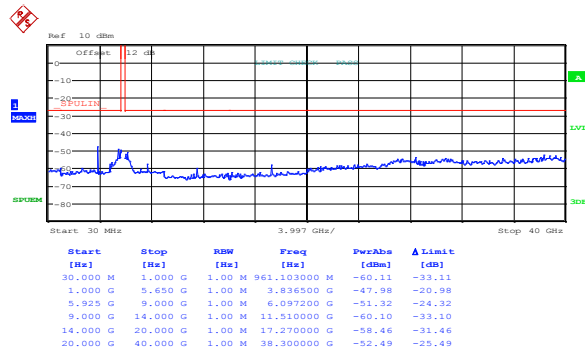

Date: 14.DEC.2016 15:32:35

Figure 8.8-44: Spurious emissions outside restricted bands at channel 151, 802.11n HT40, cho

Section 8
Test name
Specification

Testing data
 FCC 15.407(b) and RSS-247 6.2 Undesirable (unwanted) emissions
 FCC Part 15 Subpart E and RSS-247, Issue 1

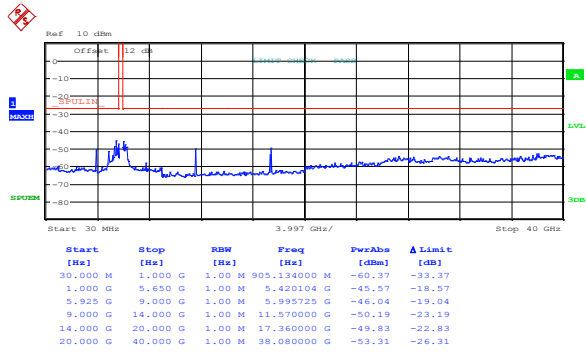

Date: 14.DEC.2016 15:29:06

Figure 8.8-45: Spurious emissions outside restricted bands at channel 157, 802.11a, cho

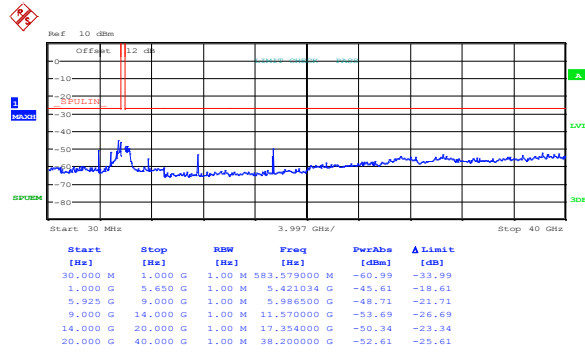

Date: 14.DEC.2016 15:31:04

Figure 8.8-46: Spurious emissions outside restricted bands at channel 157, 802.11n HT20, cho

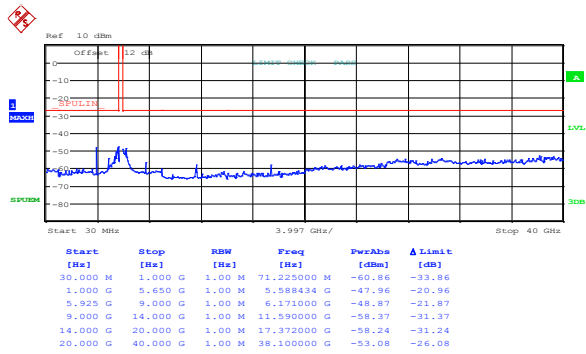

Date: 14.DEC.2016 15:33:13

Figure 8.8-47: Spurious emissions outside restricted bands at channel 159, 802.11n HT40, cho

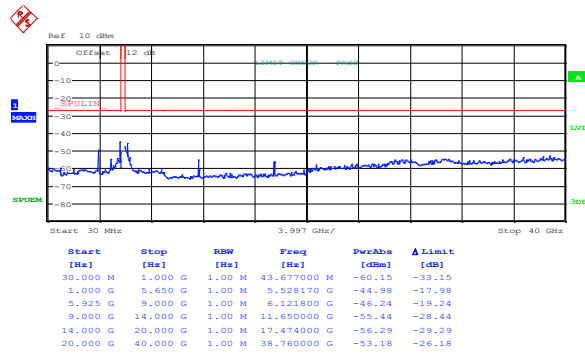

Date: 14.DEC.2016 15:29:42

Figure 8.8-48: Spurious emissions outside restricted bands at channel 165, 802.11a, cho

Section 8
Test name
Specification

Testing data
 FCC 15.407(b) and RSS-247 6.2 Undesirable (unwanted) emissions
 FCC Part 15 Subpart E and RSS-247, Issue 1

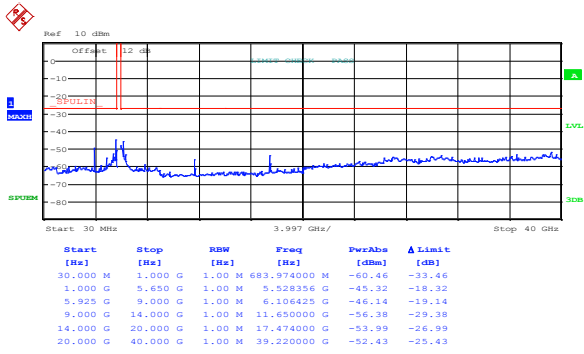

Date: 14.DEC.2016 15:31:58

Figure 8.8-49: Spurious emissions outside restricted bands at channel 165, 802.11n HT20, ch0

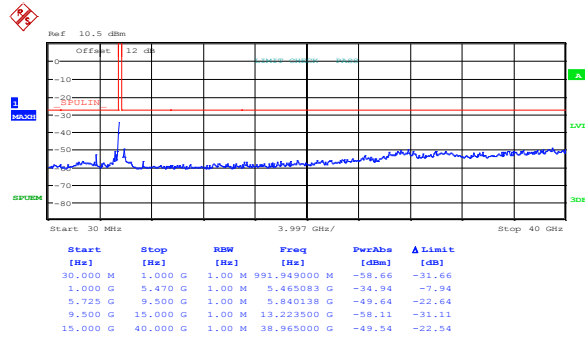

Date: 13.DEC.2016 11:12:38

Figure 8.8-50: Spurious emissions outside restricted bands at channel 100, 802.11a, ch1

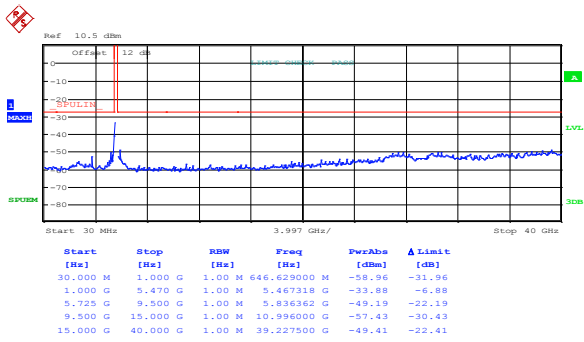

Date: 13.DEC.2016 11:18:57

Figure 8.8-51: Spurious emissions outside restricted bands at channel 100, 802.11n HT20, ch1

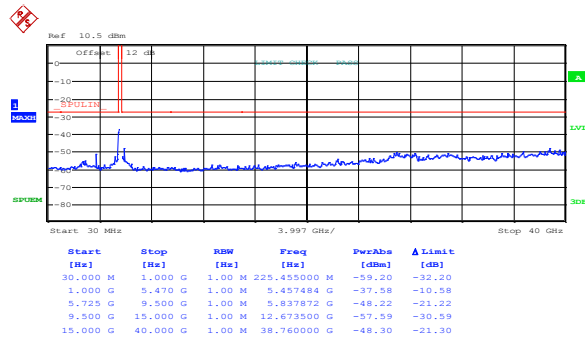

Date: 13.DEC.2016 11:11:52

Figure 8.8-52: Spurious emissions outside restricted bands at channel 102, 802.11n HT40, ch1

Section 8
Test name
Specification

Testing data
 FCC 15.407(b) and RSS-247 6.2 Undesirable (unwanted) emissions
 FCC Part 15 Subpart E and RSS-247, Issue 1

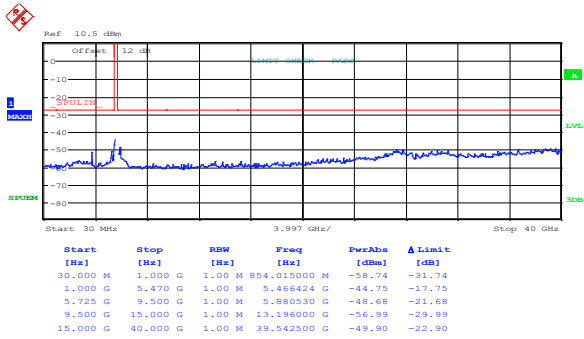

Date: 13.DEC.2016 11:11:24

Figure 8.8-53: Spurious emissions outside restricted bands at channel 110, 802.11n HT40, ch1

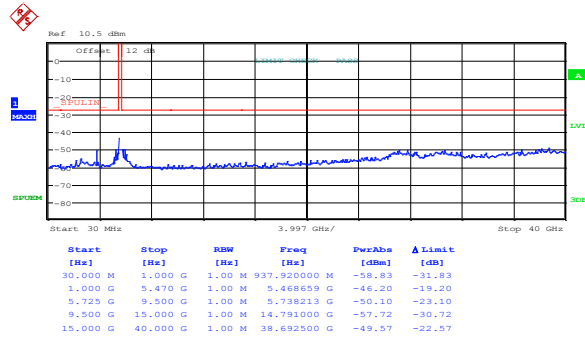

Date: 13.DEC.2016 11:17:46

Figure 8.8-54: Spurious emissions outside restricted bands at channel 116, 802.11a, ch1

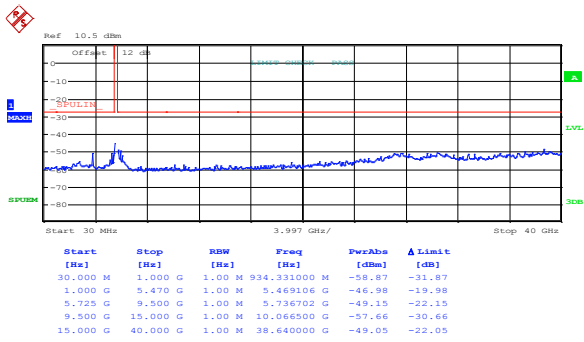

Date: 13.DEC.2016 11:19:33

Figure 8.8-55: Spurious emissions outside restricted bands at channel 116, 802.11n HT20, ch1

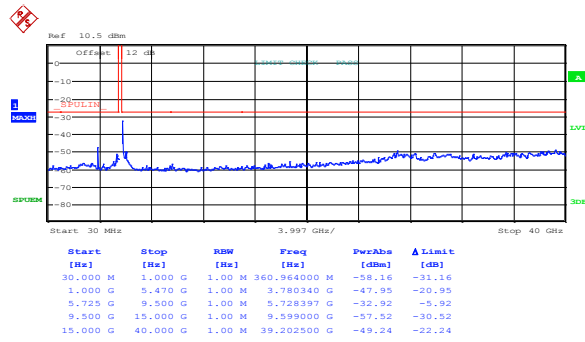

Date: 13.DEC.2016 11:10:52

Figure 8.8-56: Spurious emissions outside restricted bands at channel 134, 802.11n HT40, ch1

Section 8
Test name
Specification

Testing data
 FCC 15.407(b) and RSS-247 6.2 Undesirable (unwanted) emissions
 FCC Part 15 Subpart E and RSS-247, Issue 1

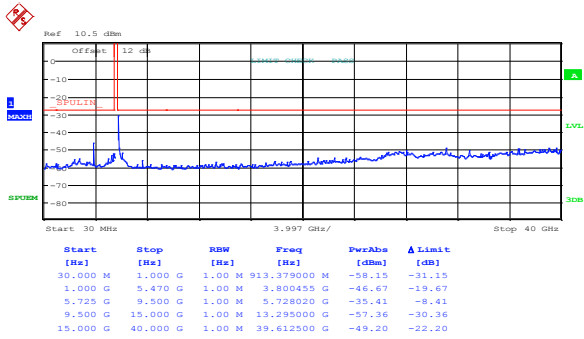

Date: 13.DEC.2016 11:18:15

Figure 8.8-57: Spurious emissions outside restricted bands at channel 140, 802.11a, ch1

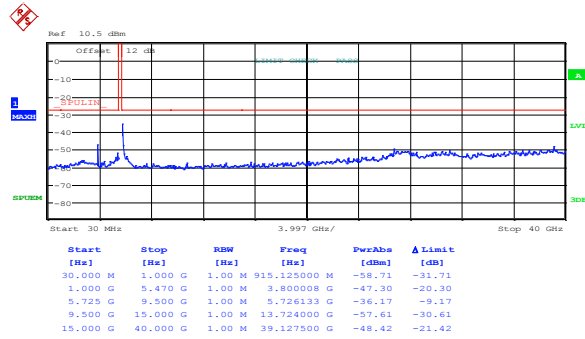

Date: 13.DEC.2016 11:20:08

Figure 8.8-58: Spurious emissions outside restricted bands at channel 140, 802.11n HT20, ch1

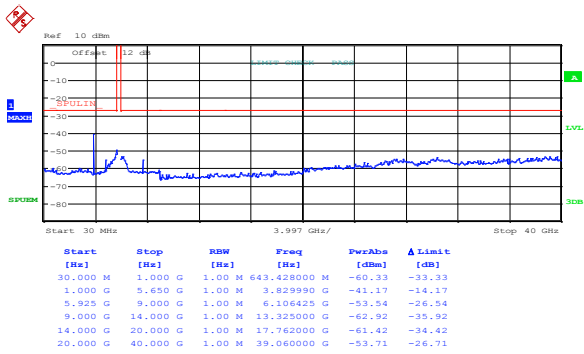

Date: 14.DEC.2016 15:20:52

Figure 8.8-59: Spurious emissions outside restricted bands at channel 149, 802.11a, ch1

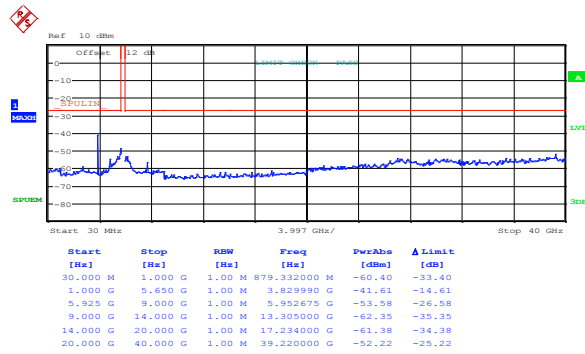

Date: 14.DEC.2016 15:23:45

Figure 8.8-60: Spurious emissions outside restricted bands at channel 149, 802.11n HT20, ch1

Section 8
Test name
Specification

Testing data
 FCC 15.407(b) and RSS-247 6.2 Undesirable (unwanted) emissions
 FCC Part 15 Subpart E and RSS-247, Issue 1

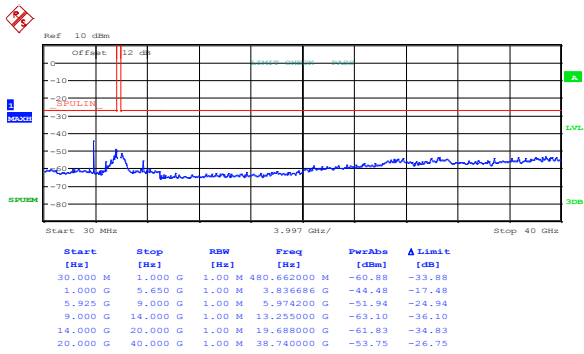

Date: 14.DEC.2016 15:26:01

Figure 8.8-61: Spurious emissions outside restricted bands at channel 151, 802.11n HT40, ch1

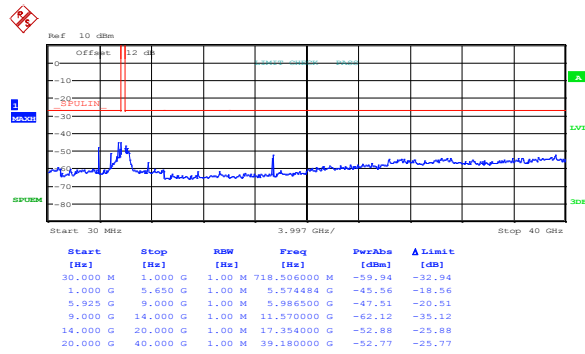

Date: 14.DEC.2016 15:22:24

Figure 8.8-62: Spurious emissions outside restricted bands at channel 157, 802.11a, ch1

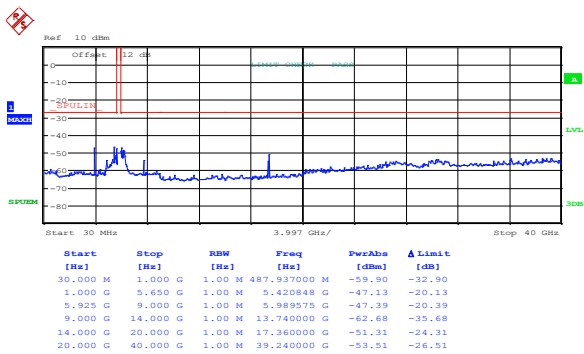

Date: 14.DEC.2016 15:24:30

Figure 8.8-63: Spurious emissions outside restricted bands at channel 157, 802.11n HT20, ch1

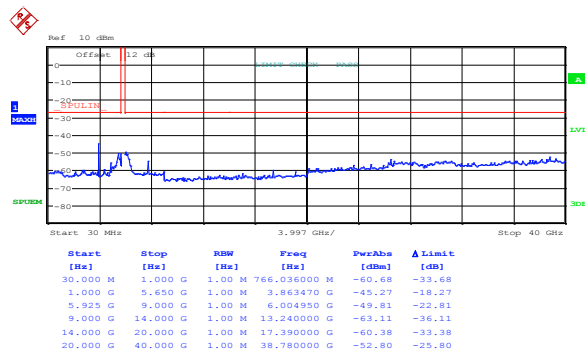

Date: 14.DEC.2016 15:26:42

Figure 8.8-64: Spurious emissions outside restricted bands at channel 159, 802.11n HT40, ch1

Section 8
Test name
Specification

Testing data
 FCC 15.407(b) and RSS-247 6.2 Undesirable (unwanted) emissions
 FCC Part 15 Subpart E and RSS-247, Issue 1

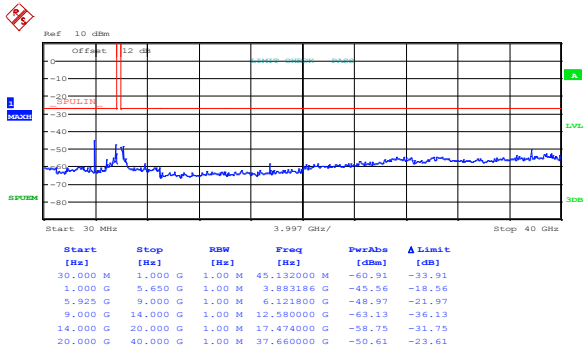

Date: 14.DEC.2016 15:23:00

Figure 8.8-65: Spurious emissions outside restricted bands at channel 165, 802.11a, ch1

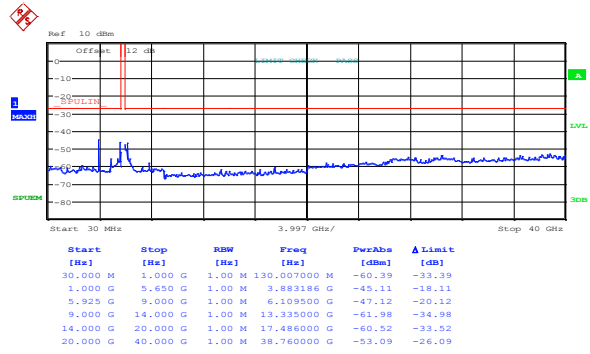

Date: 14.DEC.2016 15:25:20

Figure 8.8-66: Spurious emissions outside restricted bands at channel 165, 802.11n HT20, ch1

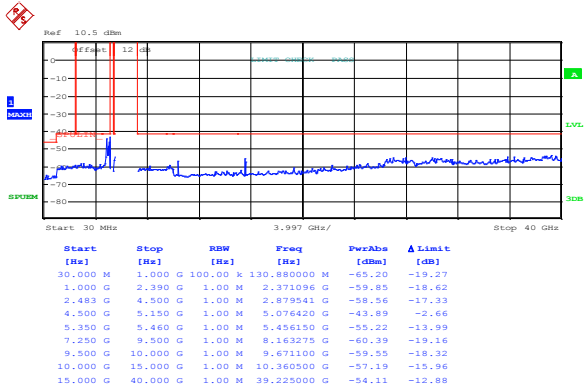

Date: 14.DEC.2016 10:54:48

Figure 8.8-67: Spurious emissions within restricted bands at channel 36, 802.11a, cho

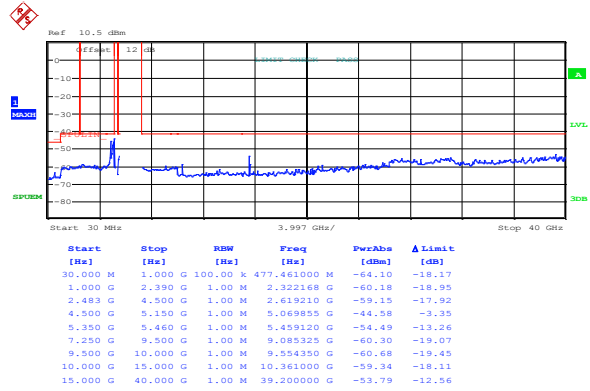

Date: 14.DEC.2016 10:59:19

Figure 8.8-68: Spurious emissions within restricted bands at channel 36, 802.11n HT20, cho

Section 8
Test name
Specification

Testing data
 FCC 15.407(b) and RSS-247 6.2 Undesirable (unwanted) emissions
 FCC Part 15 Subpart E and RSS-247, Issue 1

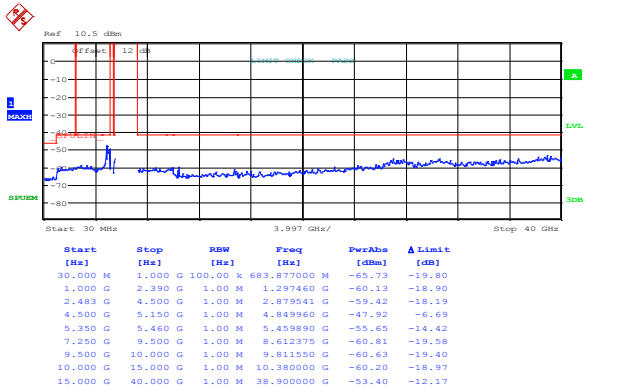

Date: 14.DEC.2016 11:03:30

Figure 8.8-69: Spurious emissions within restricted bands at channel 38, 802.11n HT40, cho

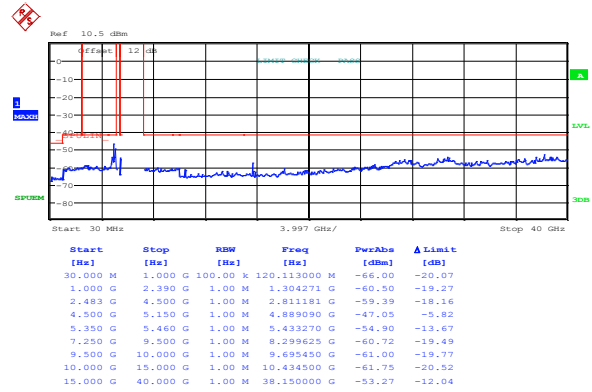

Date: 14.DEC.2016 10:55:45

Figure 8.8-70: Spurious emissions within restricted bands at channel 44, 802.11a, cho

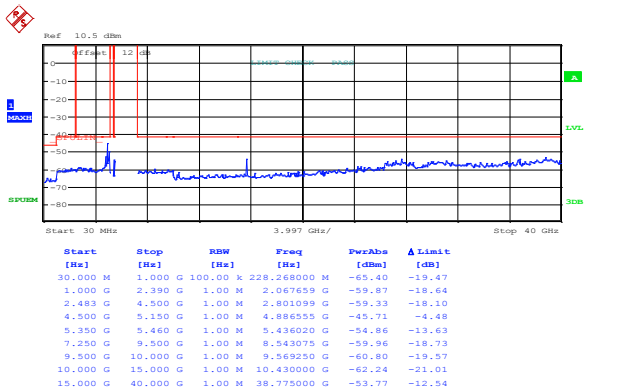

Date: 14.DEC.2016 11:00:01

Figure 8.8-71: Spurious emissions within restricted bands at channel 44, 802.11n HT20, cho

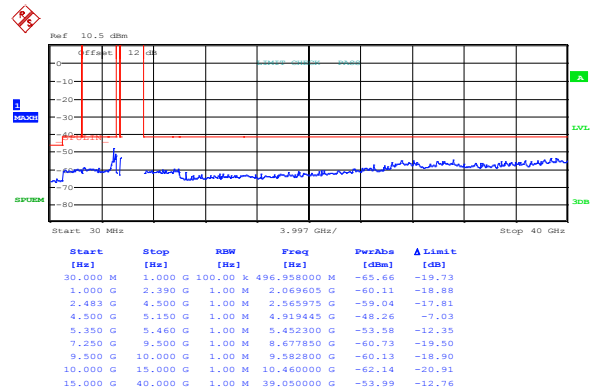

Date: 14.DEC.2016 11:04:50

Figure 8.8-72: Spurious emissions within restricted bands at channel 46, 802.11n HT40, cho

Section 8
Test name
Specification

Testing data
 FCC 15.407(b) and RSS-247 6.2 Undesirable (unwanted) emissions
 FCC Part 15 Subpart E and RSS-247, Issue 1

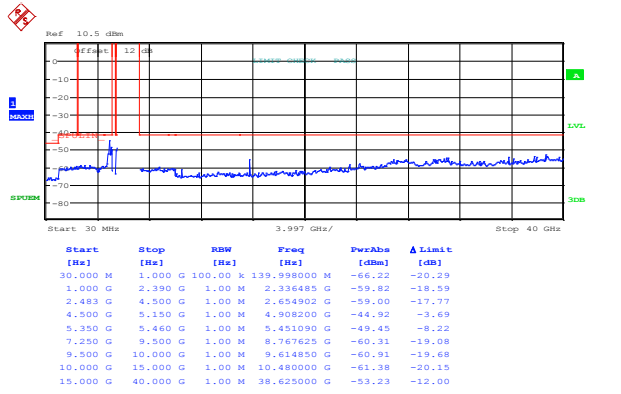

Date: 14.DEC.2016 10:56:28

Figure 8.8-73: Spurious emissions within restricted bands at channel 48, 802.11a, cho

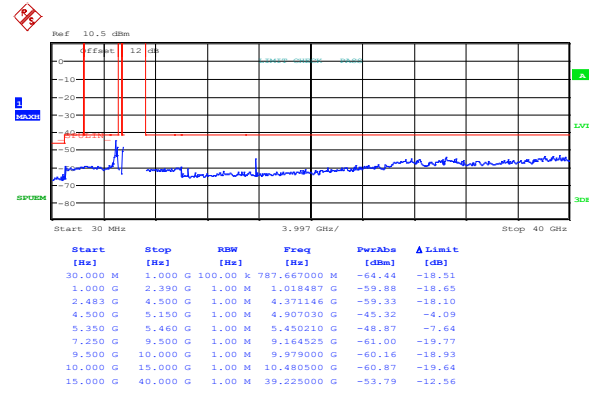

Date: 14.DEC.2016 11:00:34

Figure 8.8-74: Spurious emissions within restricted bands at channel 48, 802.11n HT20, cho

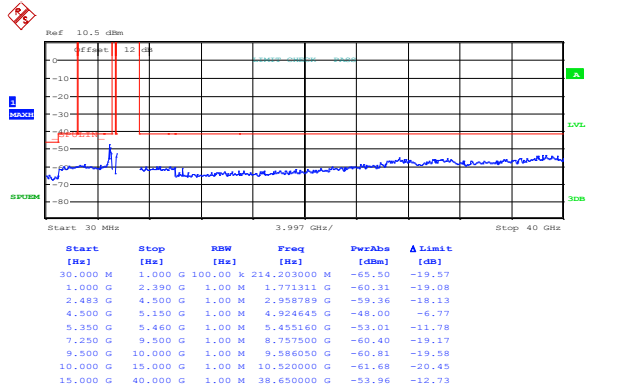

Date: 14.DEC.2016 10:57:06

Figure 8.8-75: Spurious emissions within restricted bands at channel 52, 802.11a, cho

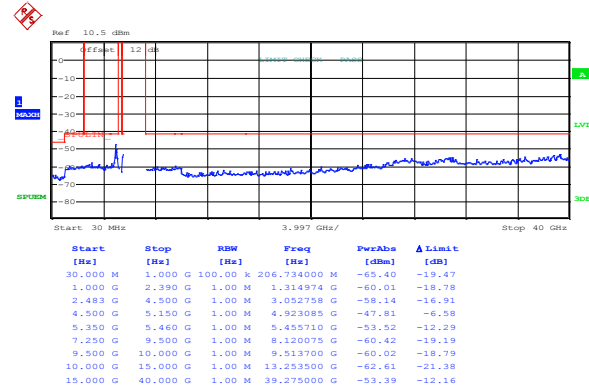

Date: 14.DEC.2016 11:01:11

Figure 8.8-76: Spurious emissions within restricted bands at channel 52, 802.11n HT20, cho

Section 8
Test name
Specification

Testing data
 FCC 15.407(b) and RSS-247 6.2 Undesirable (unwanted) emissions
 FCC Part 15 Subpart E and RSS-247, Issue 1

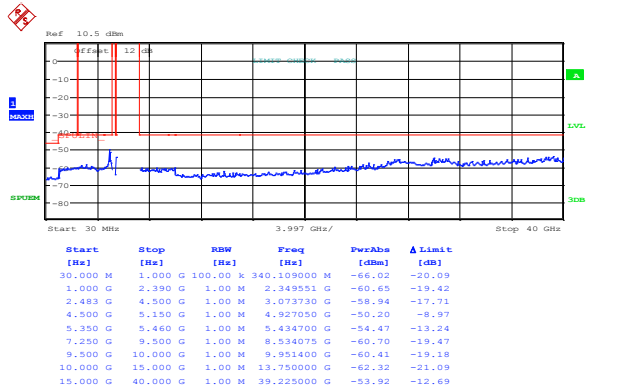

Date: 14.DEC.2016 11:05:29

Figure 8.8-77: Spurious emissions within restricted bands at channel 54, 802.11n HT40, cho

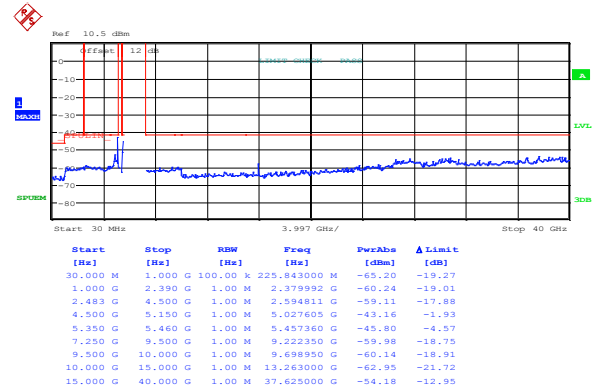

Date: 14.DEC.2016 10:58:05

Figure 8.8-78: Spurious emissions within restricted bands at channel 60, 802.11a, cho

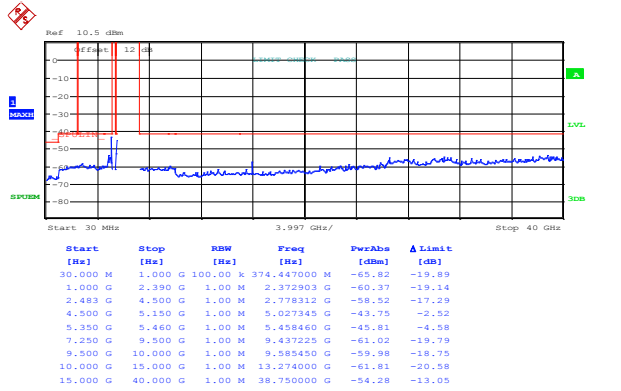

Date: 14.DEC.2016 11:01:45

Figure 8.8-79: Spurious emissions within restricted bands at channel 60, 802.11n HT20, cho

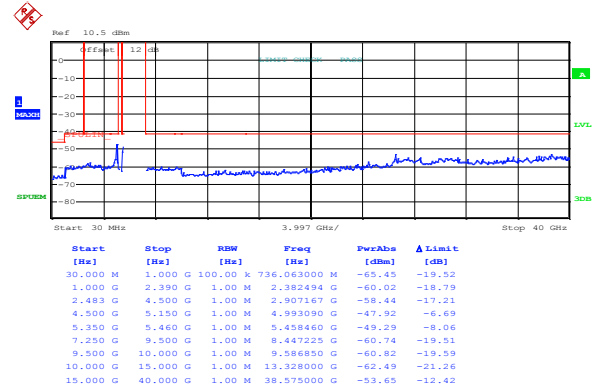

Date: 14.DEC.2016 11:06:07

Figure 8.8-80: Spurious emissions within restricted bands at channel 62, 802.11n HT40, cho

Section 8
Test name
Specification

Testing data
 FCC 15.407(b) and RSS-247 6.2 Undesirable (unwanted) emissions
 FCC Part 15 Subpart E and RSS-247, Issue 1

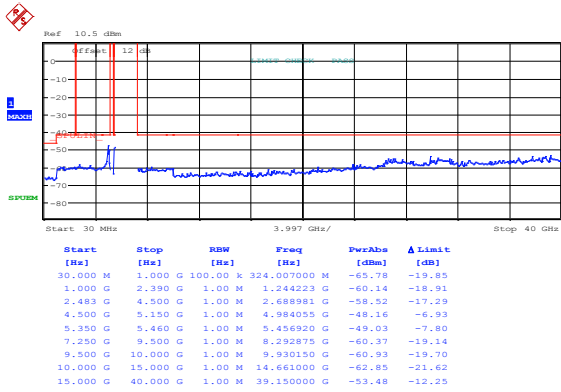

Date: 14.DEC.2016 10:58:37

Figure 8.8-81: Spurious emissions within restricted bands at channel 64, 802.11a, cho

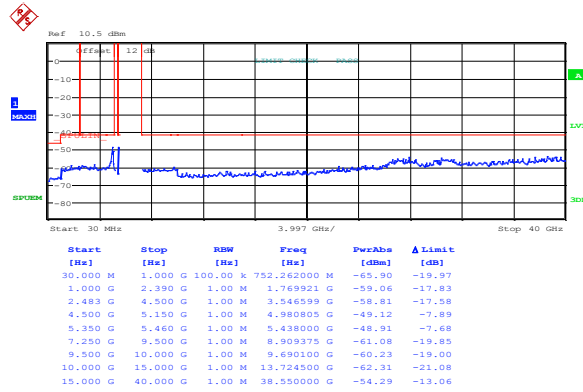

Date: 14.DEC.2016 11:02:23

Figure 8.8-82: Spurious emissions within restricted bands at channel 64, 802.11n HT20, cho

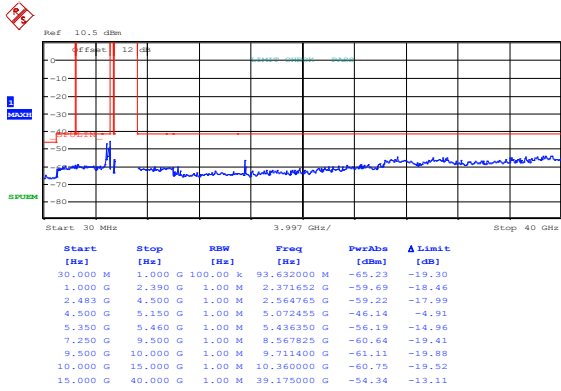

Date: 14.DEC.2016 10:09:27

Figure 8.8-83: Spurious emissions within restricted bands at channel 36, 802.11a, ch1

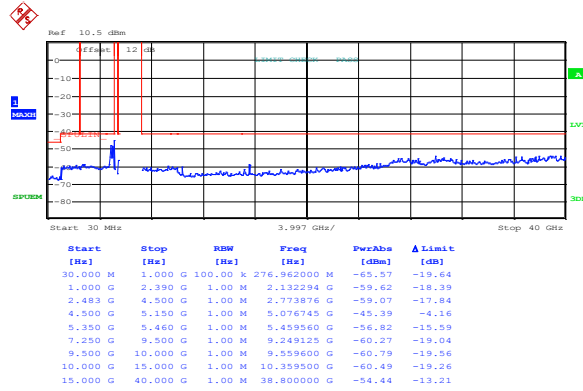

Date: 14.DEC.2016 10:13:57

Figure 8.8-84: Spurious emissions within restricted bands at channel 36, 802.11n HT20, ch1

Section 8
Test name
Specification

Testing data
 FCC 15.407(b) and RSS-247 6.2 Undesirable (unwanted) emissions
 FCC Part 15 Subpart E and RSS-247, Issue 1

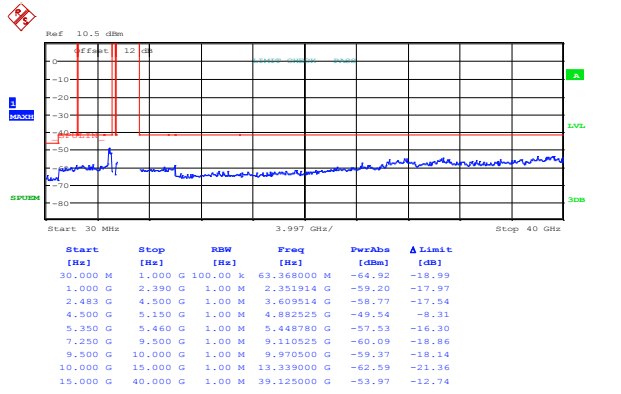

Date: 14.DEC.2016 10:18:09

Figure 8.8-85: Spurious emissions within restricted bands at channel 38, 802.11n HT40, ch1

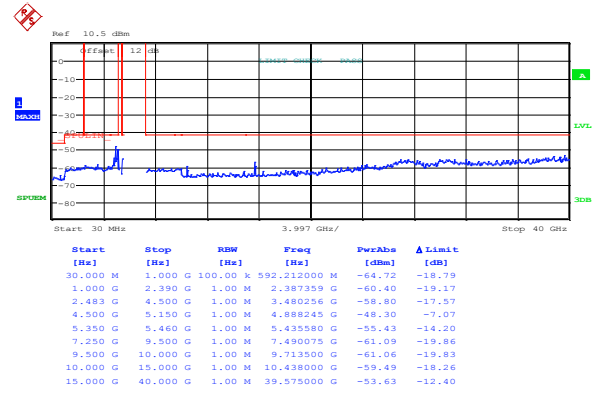

Date: 14.DEC.2016 10:09:00

Figure 8.8-86: Spurious emissions within restricted bands at channel 44, 802.11a, ch1

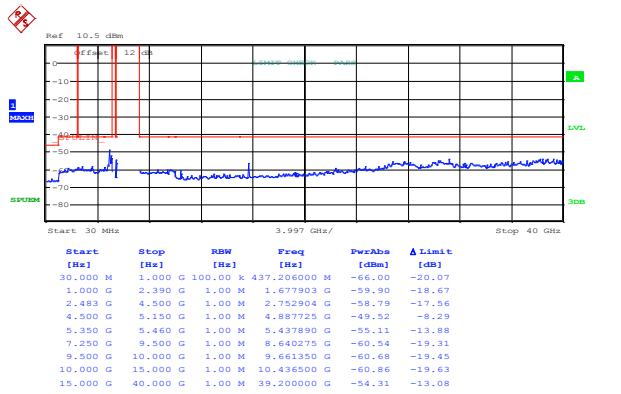

Date: 14.DEC.2016 10:14:36

Figure 8.8-87: Spurious emissions within restricted bands at channel 44, 802.11n HT20, ch1

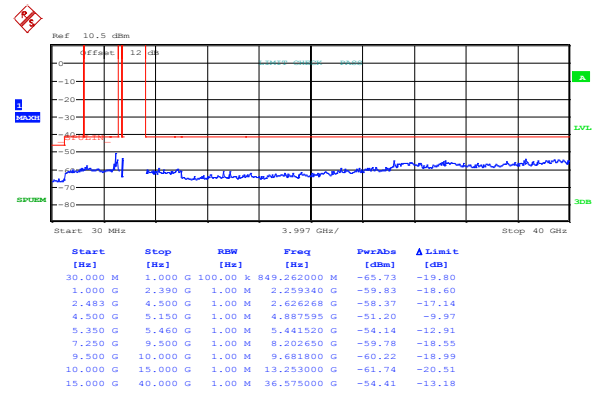

Date: 14.DEC.2016 10:34:44

Figure 8.8-88: Spurious emissions within restricted bands at channel 46, 802.11n HT40, ch1

Section 8
Test name
Specification

Testing data
 FCC 15.407(b) and RSS-247 6.2 Undesirable (unwanted) emissions
 FCC Part 15 Subpart E and RSS-247, Issue 1

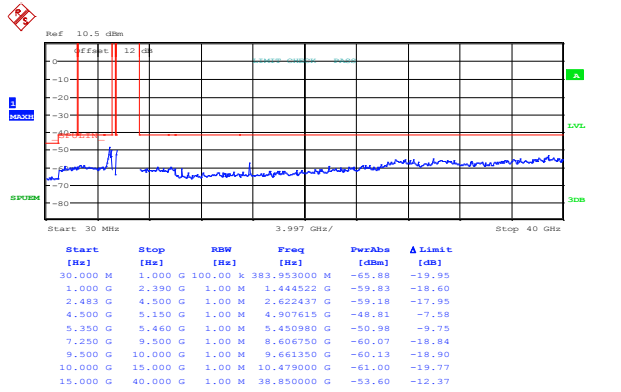

Date: 14.DEC.2016 10:10:58

Figure 8.8-89: Spurious emissions within restricted bands at channel 48, 802.11a, ch1

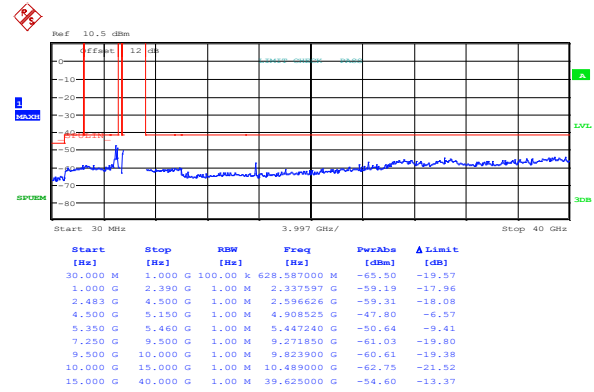

Date: 14.DEC.2016 10:15:06

Figure 8.8-90: Spurious emissions within restricted bands at channel 48, 802.11n HT20, ch1

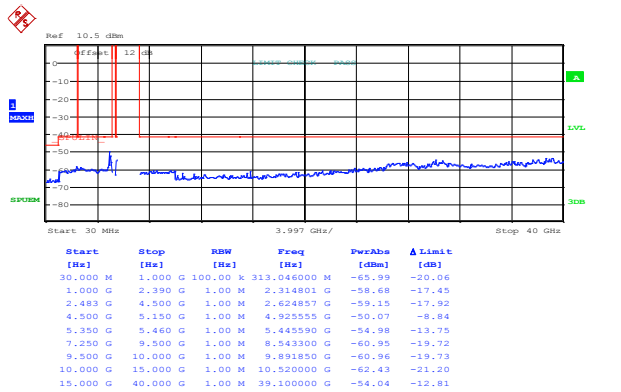

Date: 14.DEC.2016 10:11:34

Figure 8.8-91: Spurious emissions within restricted bands at channel 52, 802.11a, ch1

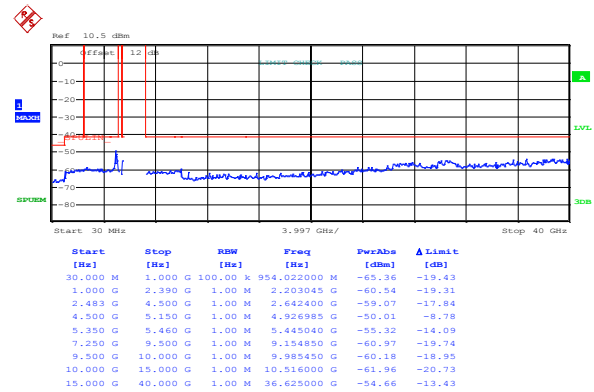

Date: 14.DEC.2016 10:15:50

Figure 8.8-92: Spurious emissions within restricted bands at channel 52, 802.11n HT20, ch1

Section 8
Test name
Specification

Testing data
 FCC 15.407(b) and RSS-247 6.2 Undesirable (unwanted) emissions
 FCC Part 15 Subpart E and RSS-247, Issue 1

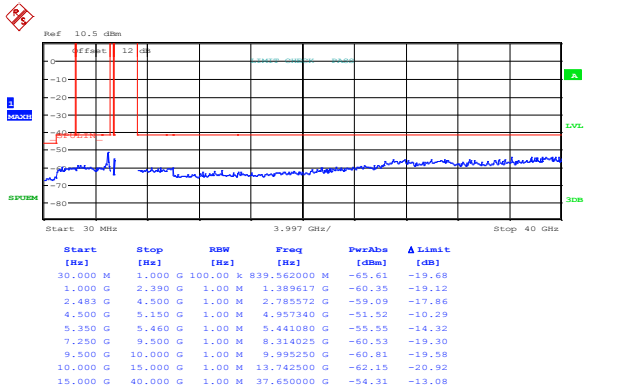

Date: 14.DEC.2016 10:35:20

Figure 8.8-93: Spurious emissions within restricted bands at channel 54, 802.11n HT40, ch1

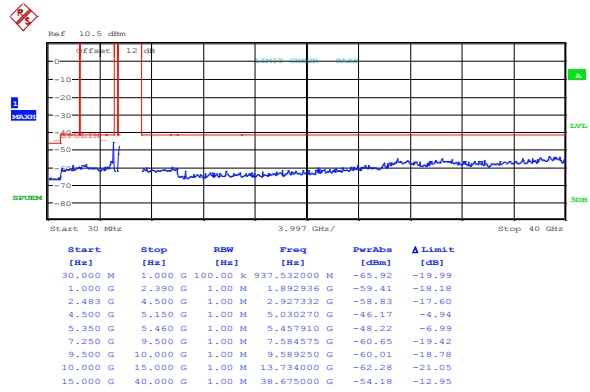

Date: 14.DEC.2016 10:12:06

Figure 8.8-94: Spurious emissions within restricted bands at channel 60, 802.11a, ch1

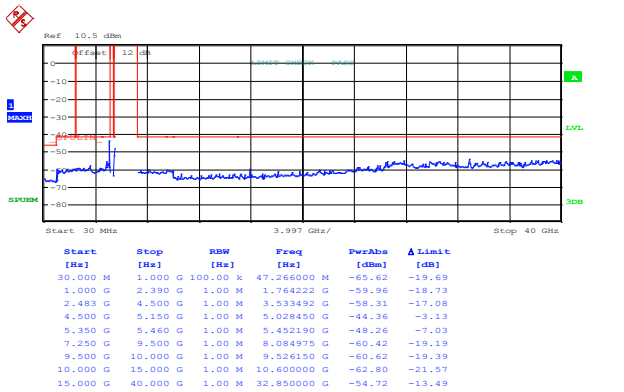

Date: 14.DEC.2016 10:16:21

Figure 8.8-95: Spurious emissions within restricted bands at channel 60, 802.11n HT20, ch1

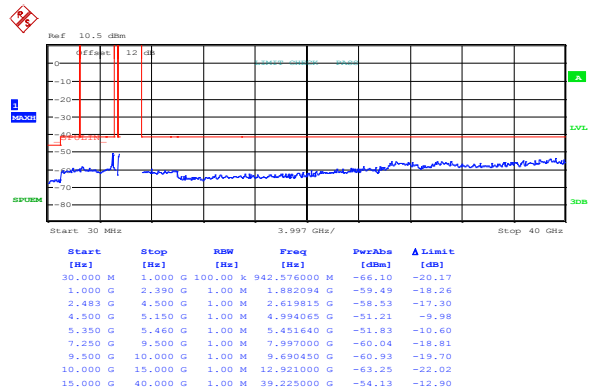

Date: 14.DEC.2016 10:36:02

Figure 8.8-96: Spurious emissions within restricted bands at channel 62, 802.11n HT40, ch1

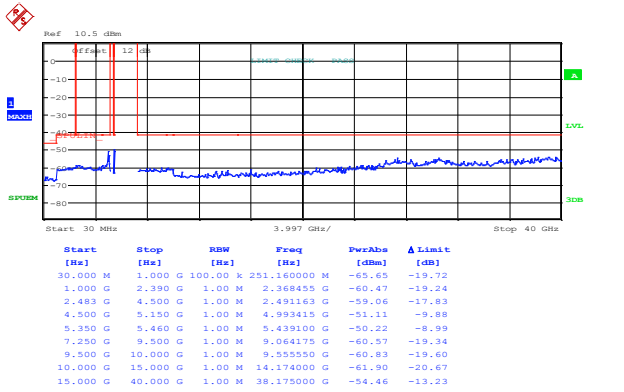

Date: 14.DEC.2016 10:12:51

Figure 8.8-97: Spurious emissions within restricted bands at channel 64, 802.11a, ch1

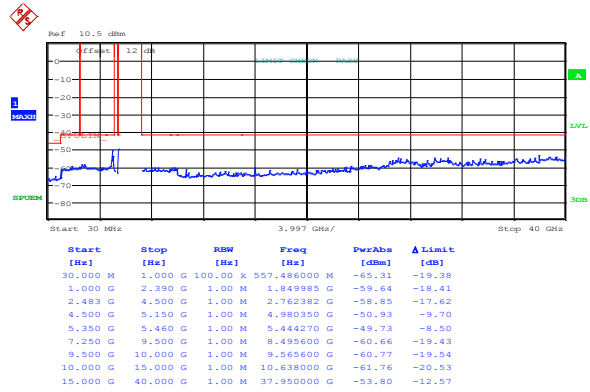

Date: 14.DEC.2016 10:16:52

Figure 8.8-98: Spurious emissions within restricted bands at channel 64, 802.11n HT20, ch1

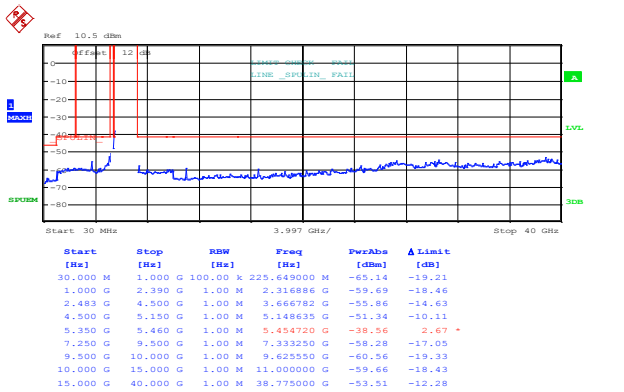

Date: 14.DEC.2016 10:45:55

Figure 8.8-99: Spurious emissions within restricted bands at channel 100, 802.11a, cho

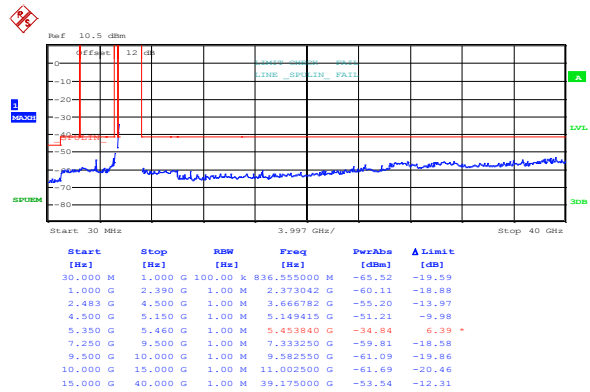

Date: 14.DEC.2016 10:47:57

Figure 8.8-100: Spurious emissions within restricted bands at channel 100, 802.11n HT20, cho

Note: exceeding level of the emission on the plot above is covered in band edge emission plot further down in the report.

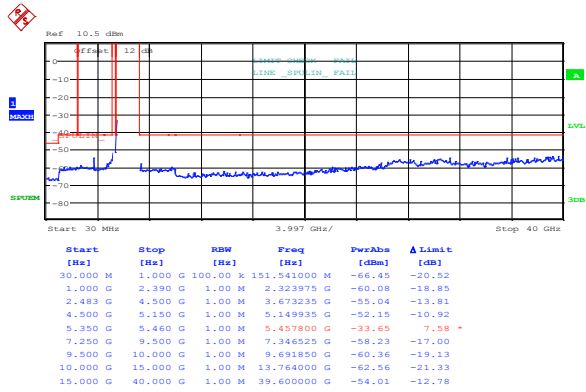

Date: 14.DEC.2016 10:43:00

Figure 8.8-101: Spurious emissions within restricted bands at channel 102, 802.11n HT40, cho

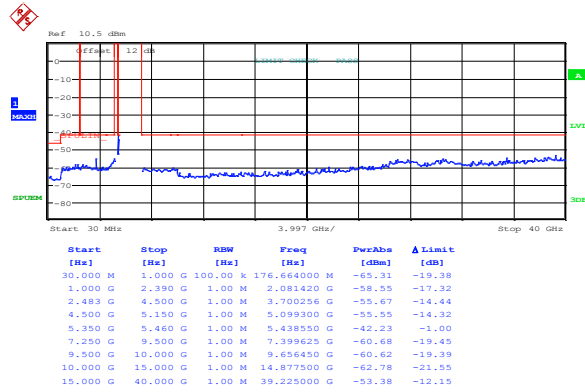

Date: 14.DEC.2016 10:44:12

Figure 8.8-102: Spurious emissions within restricted bands at channel 64, 802.11n HT40, cho

Note: exceeding level of the emission on the plot above is covered in band edge emission plot further down in the report.

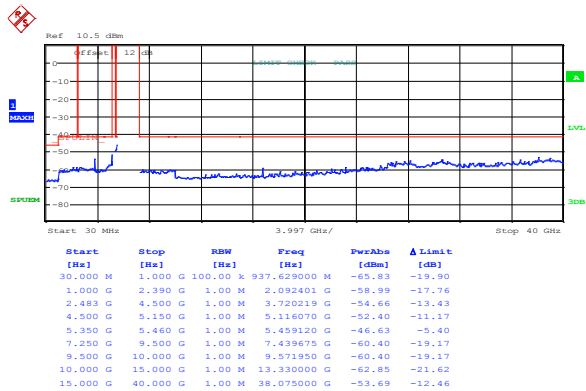

Date: 14.DEC.2016 10:46:43

Figure 8.8-103: Spurious emissions within restricted bands at channel 116, 802.11a, cho

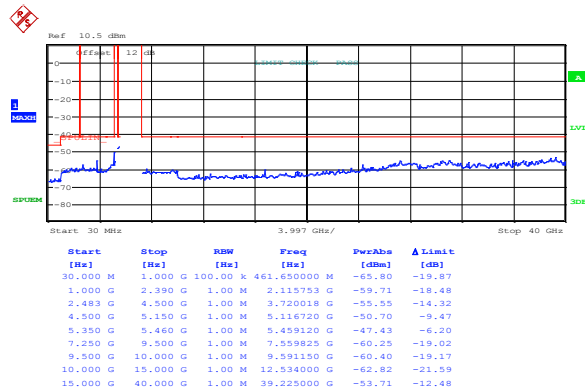

Date: 14.DEC.2016 10:48:30

Figure 8.8-104: Spurious emissions within restricted bands at channel 116, 802.11n HT20, cho

Section 8
Test name
Specification

Testing data
 FCC 15.407(b) and RSS-247 6.2 Undesirable (unwanted) emissions
 FCC Part 15 Subpart E and RSS-247, Issue 1

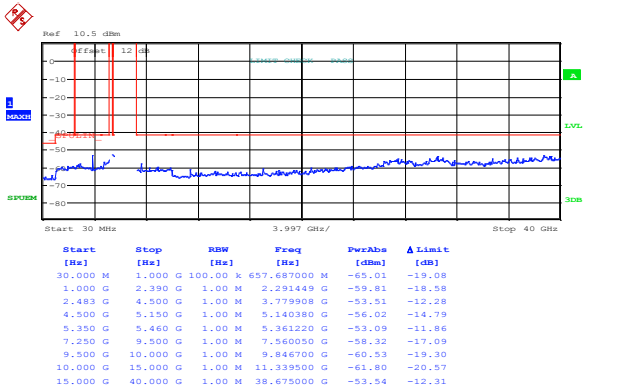

Date: 14.DEC.2016 10:44:58

Figure 8.8-105: Spurious emissions within restricted bands at channel 134, 802.11n HT40, cho

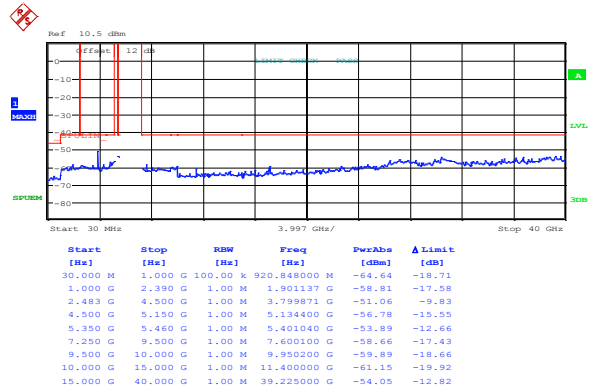

Date: 14.DEC.2016 10:47:14

Figure 8.8-106: Spurious emissions within restricted bands at channel 140, 802.11a, cho

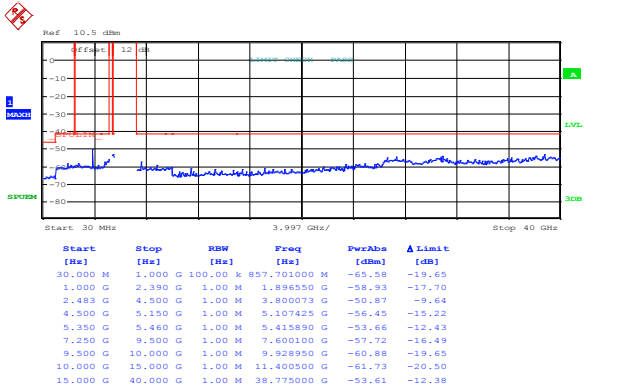

Date: 14.DEC.2016 10:49:08

Figure 8.8-107: Spurious emissions within restricted bands at channel 140, 802.11n HT20, cho

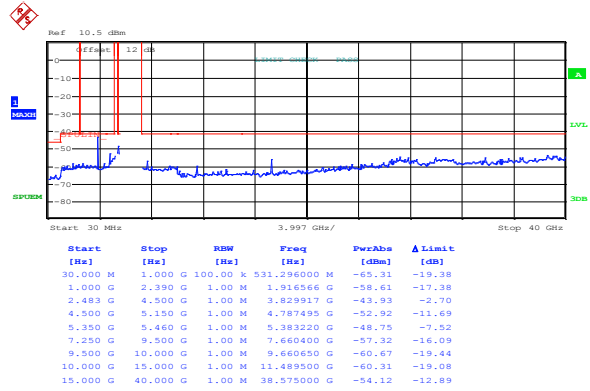

Date: 14.DEC.2016 12:08:37

Figure 8.8-108: Spurious emissions within restricted bands at channel 149, 802.11a, cho

Section 8
Test name
Specification

Testing data
 FCC 15.407(b) and RSS-247 6.2 Undesirable (unwanted) emissions
 FCC Part 15 Subpart E and RSS-247, Issue 1

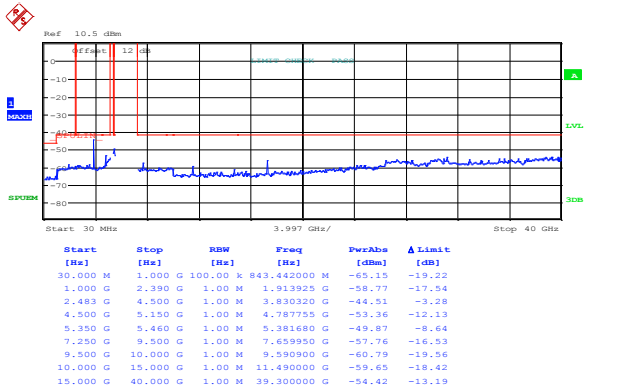

Date: 14.DEC.2016 12:11:28

Figure 8.8-109: Spurious emissions within restricted bands at channel 149, 802.11n HT20, cho

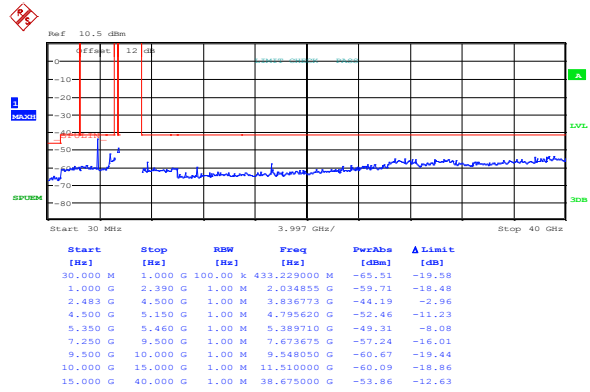

Date: 14.DEC.2016 12:13:21

Figure 8.8-110: Spurious emissions within restricted bands at channel 151, 802.11n HT40, cho

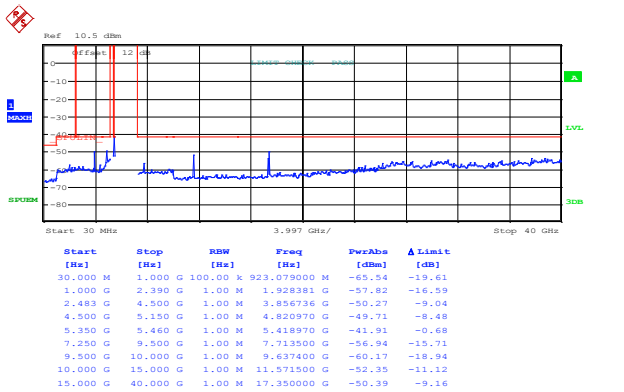

Date: 14.DEC.2016 12:10:04

Figure 8.8-111: Spurious emissions within restricted bands at channel 157, 802.11a, cho

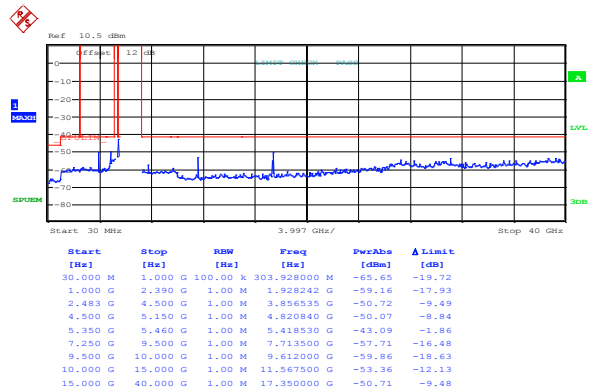

Date: 14.DEC.2016 12:12:03

Figure 8.8-112: Spurious emissions within restricted bands at channel 157, 802.11n HT20, cho

Section 8
Test name
Specification

Testing data
 FCC 15.407(b) and RSS-247 6.2 Undesirable (unwanted) emissions
 FCC Part 15 Subpart E and RSS-247, Issue 1

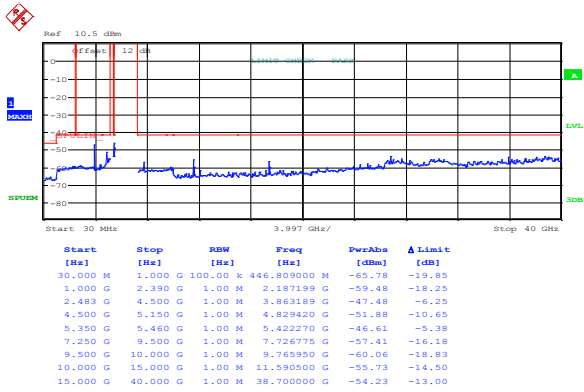

Date: 14.DEC.2016 12:13:57

Figure 8.8-113: Spurious emissions within restricted bands at channel 159, 802.11n HT40, cho

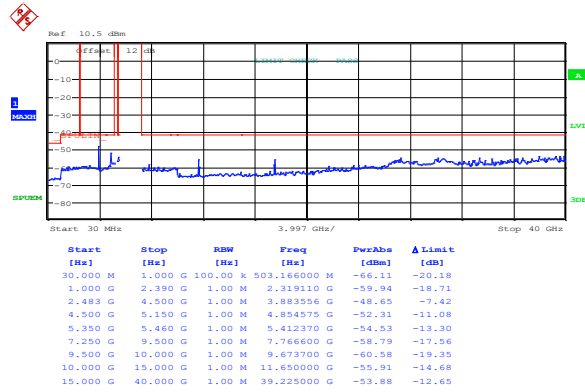

Date: 14.DEC.2016 12:10:41

Figure 8.8-114: Spurious emissions within restricted bands at channel 165, 802.11a, cho

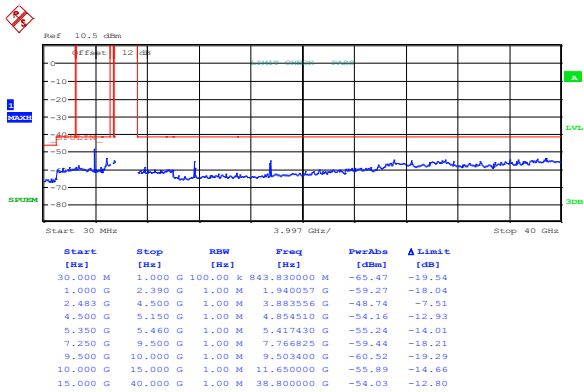

Date: 14.DEC.2016 12:12:37

Figure 8.8-115: Spurious emissions within restricted bands at channel 165, 802.11n HT20, cho

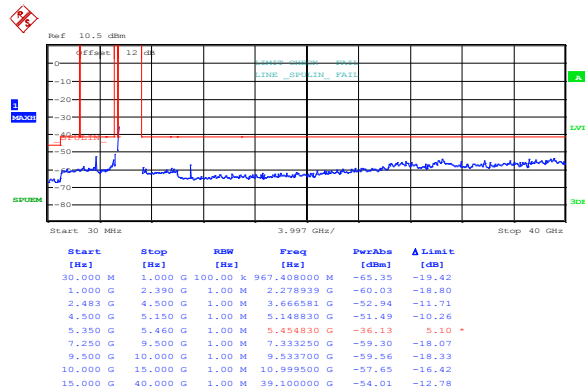

Date: 13.DEC.2016 11:42:35

Figure 8.8-116: Spurious emissions within restricted bands at channel 100, 802.11a, ch1

Note: 5.46 GHz lower band edge measurement results:

Table 8.8-4: Restricted band edge measurement result

Frequency, MHz	Peak power, dBm	Peak limit, dBm	Margin, dB	Average power, dBm	Average limit, dBm	Margin, dB
5460	-35.11	-21.23	13.88	-44.67	-41.23	3.44

Section 8
Test name
Specification

Testing data
 FCC 15.407(b) and RSS-247 6.2 Undesirable (unwanted) emissions
 FCC Part 15 Subpart E and RSS-247, Issue 1

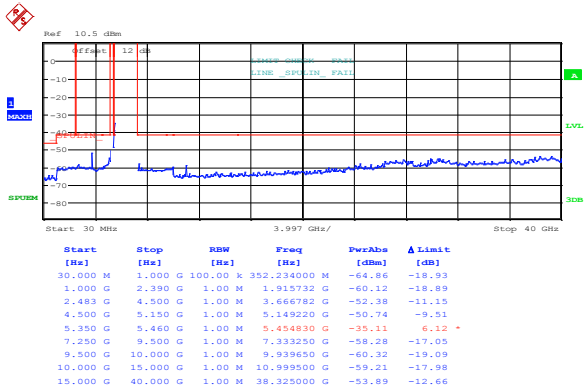

Date: 13.DEC.2016 11:35:37

Figure 8.8-117: Spurious emissions within restricted bands at channel 100, 802.11n HT20, ch1

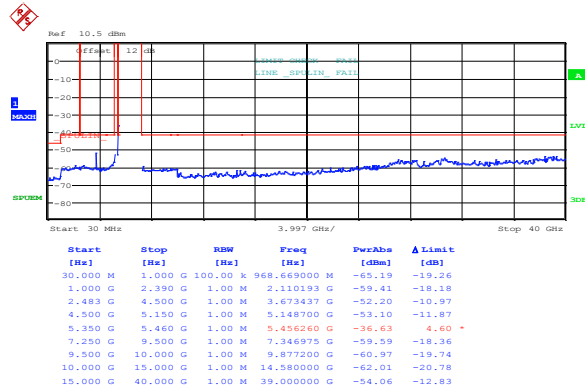

Date: 13.DEC.2016 11:46:16

Figure 8.8-118: Spurious emissions within restricted bands at channel 102, 802.11n HT40, ch1

Note: 5.46 GHz lower band edge measurement results:

Table 8.8-5: Restricted band edge measurement result

Frequency, MHz	Peak power, dBm	Peak limit, dBm	Margin, dB	Average power, dBm	Average limit, dBm	Margin, dB
5460	-34.72	-21.23	13.49	-44.13	-41.23	2.90

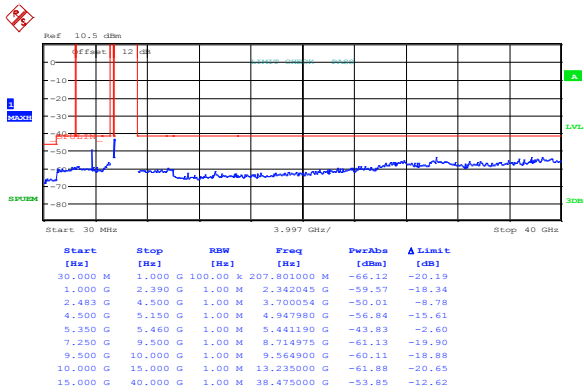

Date: 13.DEC.2016 11:47:14

Figure 8.8-119: Spurious emissions within restricted bands at channel 110, 802.11n HT40, ch1

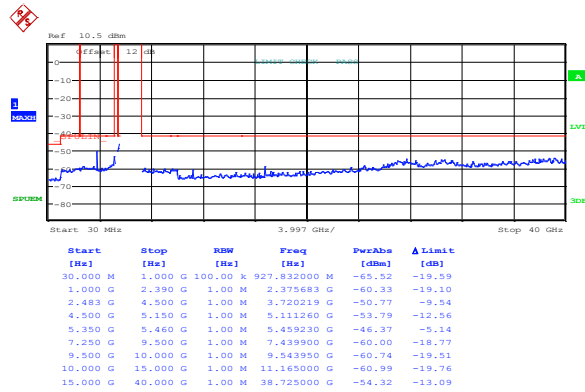

Date: 13.DEC.2016 11:43:24

Figure 8.8-120: Spurious emissions within restricted bands at channel 116, 802.11a, ch1

Section 8
Test name
Specification

Testing data
 FCC 15.407(b) and RSS-247 6.2 Undesirable (unwanted) emissions
 FCC Part 15 Subpart E and RSS-247, Issue 1

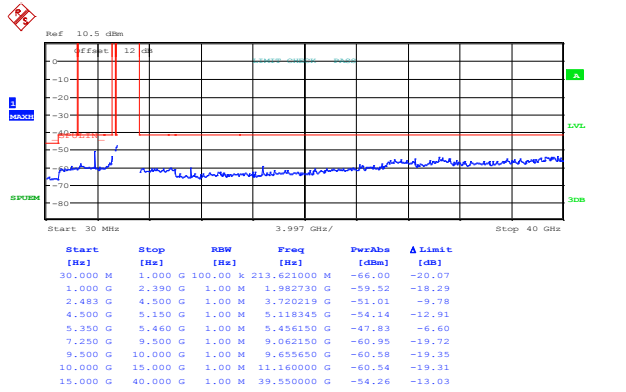

Date: 13.DEC.2016 11:34:28

Figure 8.8-121: Spurious emissions within restricted bands at channel 116, 802.11n HT20, ch1

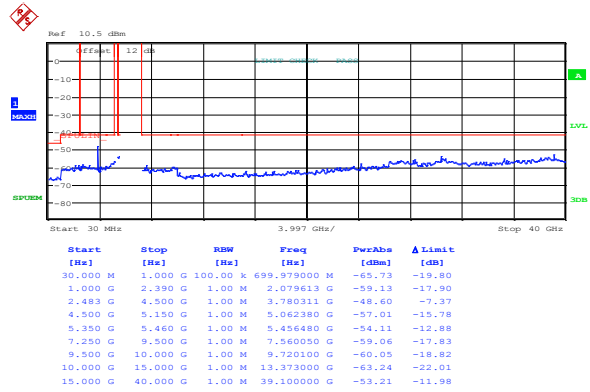

Date: 13.DEC.2016 11:48:24

Figure 8.8-122: Spurious emissions within restricted bands at channel 134, 802.11n HT40, ch1

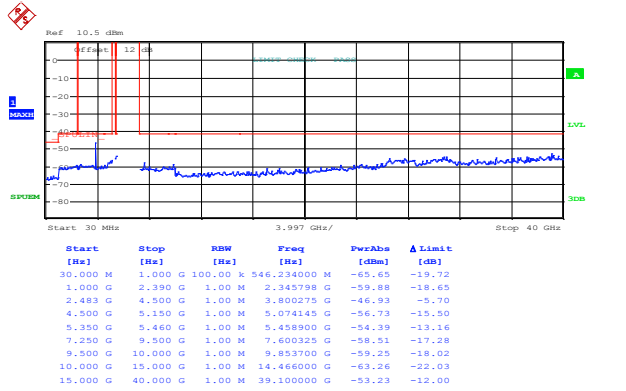

Date: 13.DEC.2016 11:43:59

Figure 8.8-123: Spurious emissions within restricted bands at channel 140, 802.11a, ch1

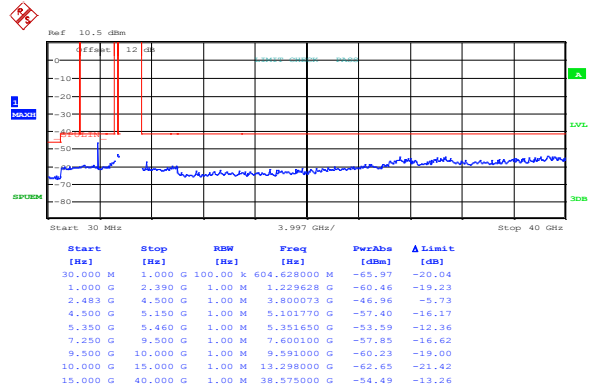

Date: 13.DEC.2016 11:32:27

Figure 8.8-124: Spurious emissions within restricted bands at channel 140, 802.11n HT20, ch1

Section 8
Test name
Specification

Testing data
 FCC 15.407(b) and RSS-247 6.2 Undesirable (unwanted) emissions
 FCC Part 15 Subpart E and RSS-247, Issue 1

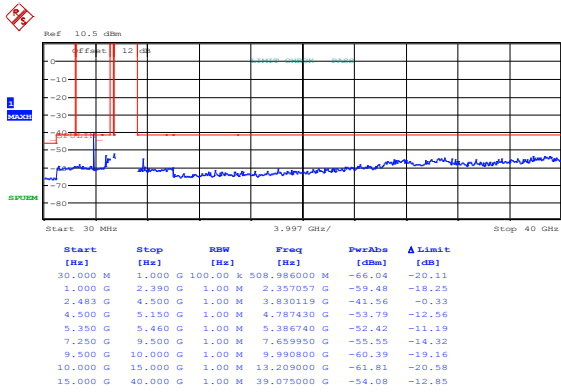

Date: 14.DEC.2016 12:15:27

Figure 8.8-125: Spurious emissions within restricted bands at channel 149, 802.11a, ch1

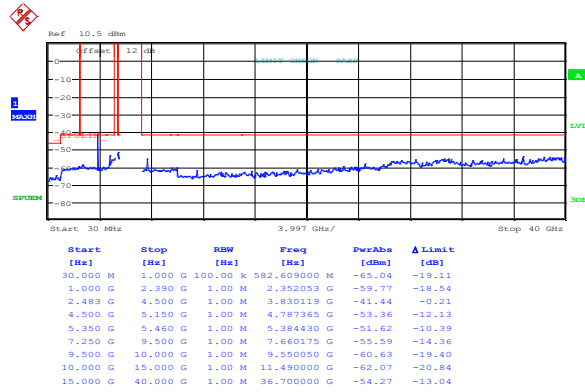

Date: 14.DEC.2016 12:17:33

Figure 8.8-126: Spurious emissions within restricted bands at channel 149, 802.11n HT20, ch1

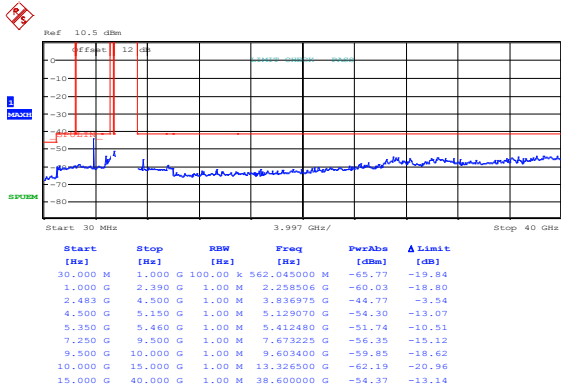

Date: 14.DEC.2016 12:19:37

Figure 8.8-127: Spurious emissions within restricted bands at channel 151, 802.11n HT40, ch1

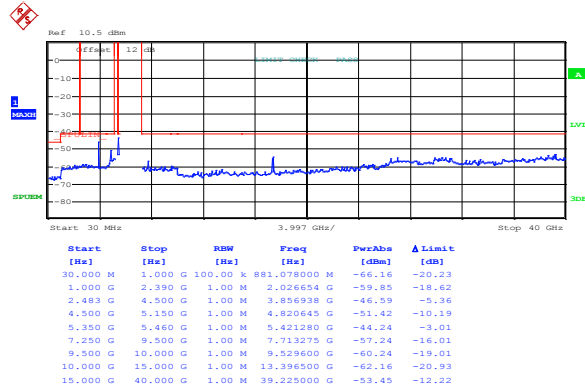

Date: 14.DEC.2016 12:16:14

Figure 8.8-128: Spurious emissions within restricted bands at channel 157, 802.11a, ch1

Section 8
Test name
Specification

Testing data
 FCC 15.407(b) and RSS-247 6.2 Undesirable (unwanted) emissions
 FCC Part 15 Subpart E and RSS-247, Issue 1

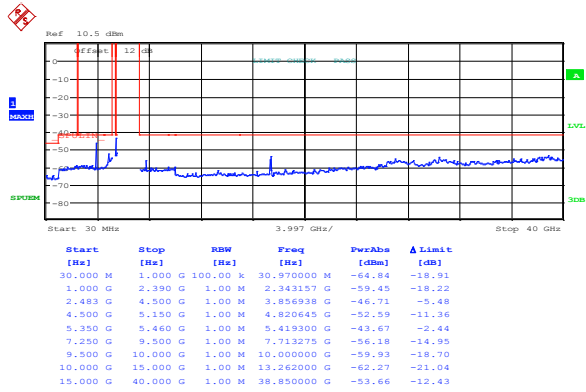

Date: 14.DEC.2016 12:18:16

Figure 8.8-129: Spurious emissions within restricted bands at channel 157, 802.11n HT20, ch1

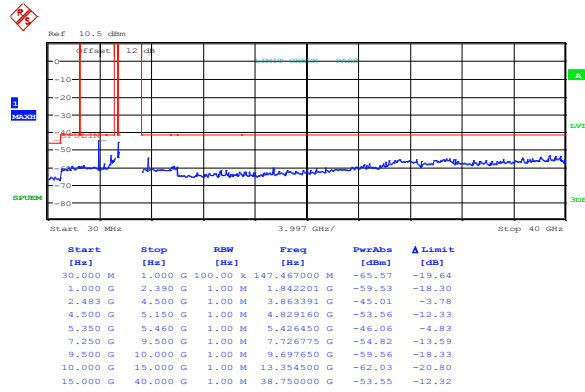

Date: 14.DEC.2016 12:20:29

Figure 8.8-130: Spurious emissions within restricted bands at channel 159, 802.11n HT40, ch1

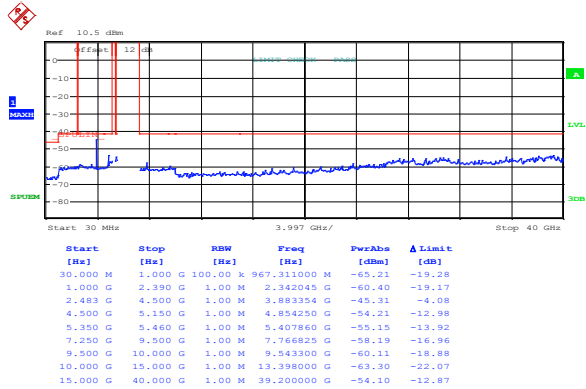

Date: 14.DEC.2016 12:16:52

Figure 8.8-131: Spurious emissions within restricted bands at channel 165, 802.11a, ch1

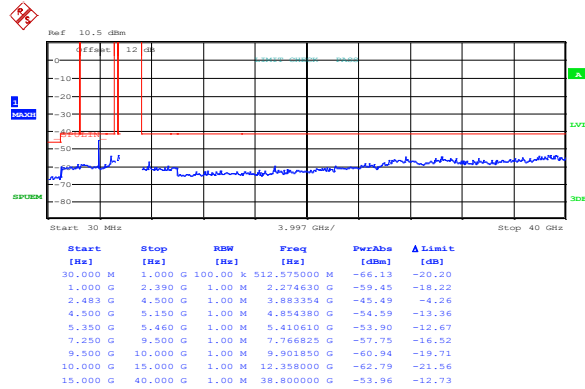

Date: 14.DEC.2016 12:18:52

Figure 8.8-132: Spurious emissions within restricted bands at channel 165, 802.11n HT20, ch1

Section 8
Test name
Specification

Testing data
 FCC 15.407(b) and RSS-247 6.2 Undesirable (unwanted) emissions
 FCC Part 15 Subpart E and RSS-247, Issue 1

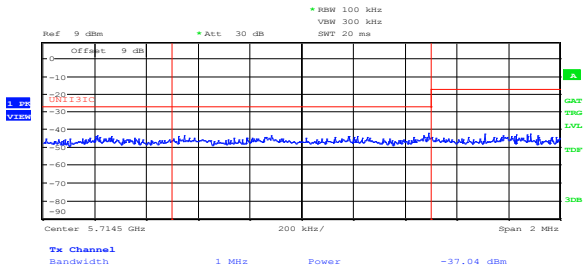

Date: 9.JAN.2017 10:52:17

Figure 8.8-133: Lower band edge emission at 5715 MHz, channel 149, 802.11a, cho

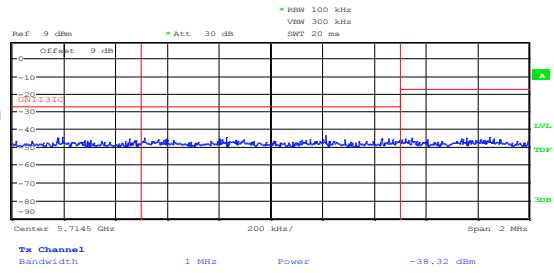

Date: 9.JAN.2017 10:55:26

Figure 8.8-134: Lower band edge emission at 5715 MHz, channel 149, 802.11n HT20, cho

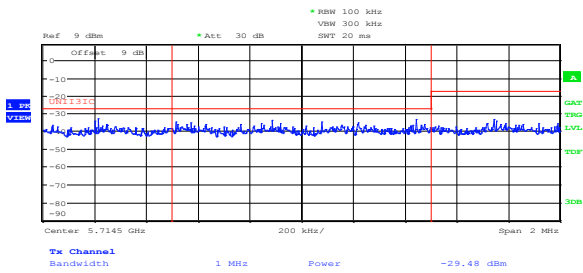

Date: 9.JAN.2017 10:58:35

Figure 8.8-135: Lower band edge emission at 5715 MHz, channel 151, 802.11n HT40, cho

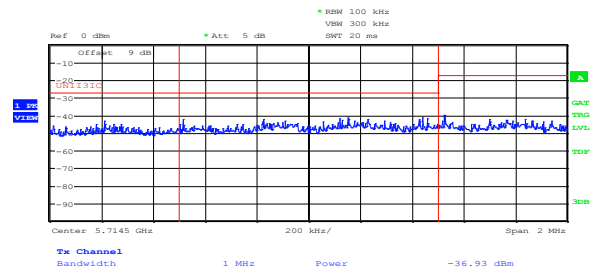

Date: 9.JAN.2017 11:50:36

Figure 8.8-136: Lower band edge emission at 5715 MHz, channel 149, 802.11a, ch1

Section 8
Test name
Specification

Testing data
 FCC 15.407(b) and RSS-247 6.2 Undesirable (unwanted) emissions
 FCC Part 15 Subpart E and RSS-247, Issue 1

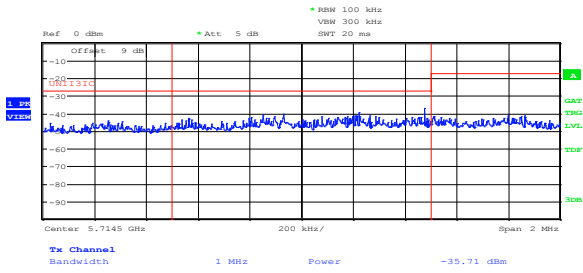

Date: 9.JAN.2017 11:48:24

Figure 8.8-137: Lower band edge emission at 5715 MHz, channel 149, 802.11n HT20, ch1

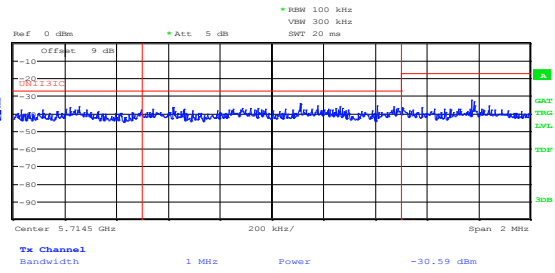

Date: 9.JAN.2017 11:47:23

Figure 8.8-138: Lower band edge emission at 5715 MHz, channel 151, 802.11n HT40, ch1



Date: 9.JAN.2017 10:50:33

Figure 8.8-139: Lower band edge emission at 5725 MHz, channel 149, 802.11a, cho

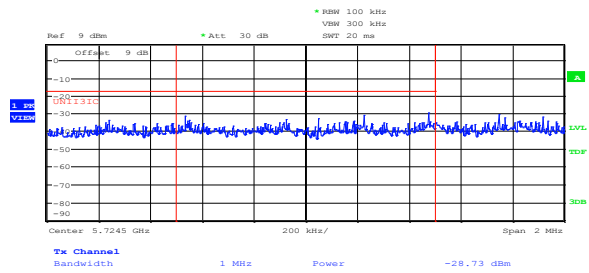

Date: 9.JAN.2017 10:56:06

Figure 8.8-140: Lower band edge emission at 5725 MHz, channel 149, 802.11n HT20, ch1

Section 8
Test name
Specification

Testing data
 FCC 15.407(b) and RSS-247 6.2 Undesirable (unwanted) emissions
 FCC Part 15 Subpart E and RSS-247, Issue 1



Date: 9.JAN.2017 10:58:04

Figure 8.8-141: Lower band edge emission at 5725 MHz, channel 151, 802.11n HT40, cho

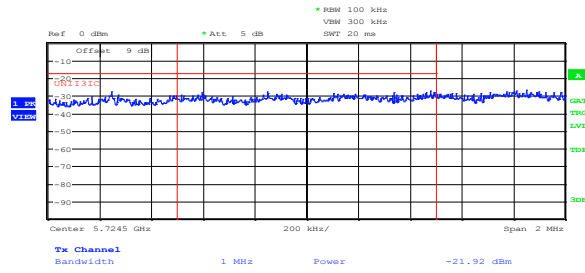

Date: 9.JAN.2017 11:50:12

Figure 8.8-142: Lower band edge emission at 5725 MHz, channel 149, 802.11a, ch1

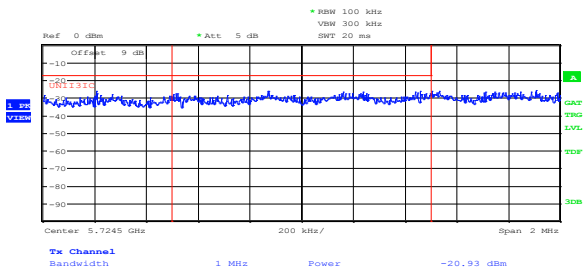

Date: 9.JAN.2017 11:49:26

Figure 8.8-143: Lower band edge emission at 5725 MHz, channel 149, 802.11n HT20, ch1

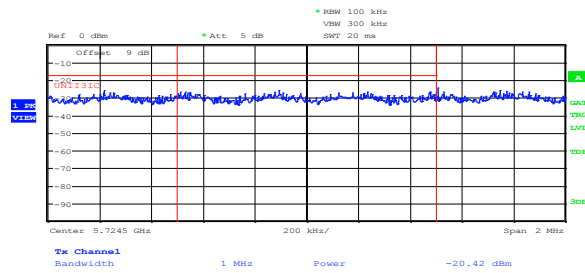

Date: 9.JAN.2017 11:46:57

Figure 8.8-144: Lower band edge emission at 5725 MHz, channel 151, 802.11n HT40, ch1

Section 8
Test name
Specification

Testing data
 FCC 15.407(b) and RSS-247 6.2 Undesirable (unwanted) emissions
 FCC Part 15 Subpart E and RSS-247, Issue 1

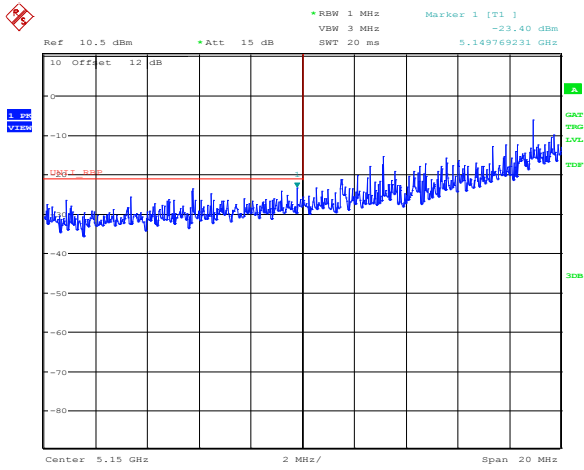

Date: 13.DEC.2016 09:32:11

Figure 8.8-145: Lower band edge emission at 5150 MHz, channel 36, 802.11a, cho, Peak

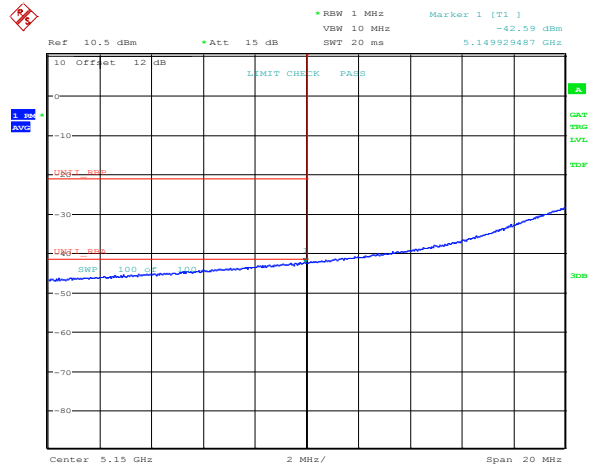

Date: 13.DEC.2016 09:32:53

Figure 8.8-146: Lower band edge emission at 5150 MHz, channel 36, 802.11a, cho, Average

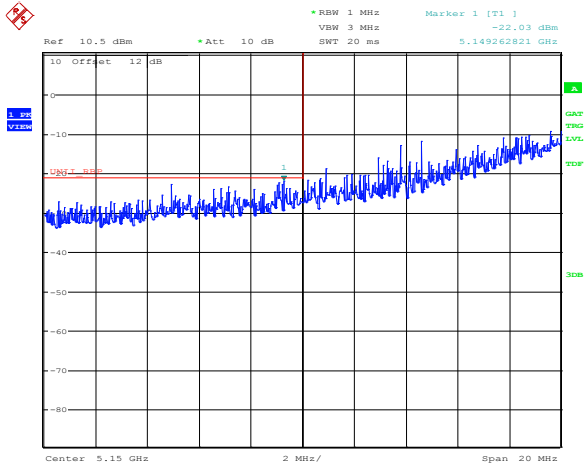

Date: 13.DEC.2016 09:35:34

Figure 8.8-147: Lower band edge emission at 5150 MHz, channel 36, 802.11n HT20, cho, Peak

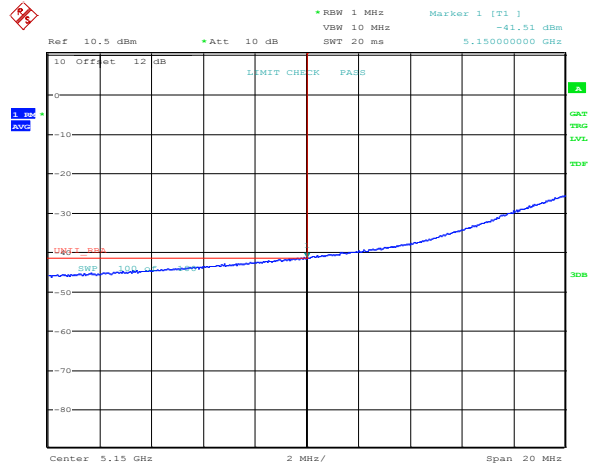

Date: 13.DEC.2016 09:34:34

Figure 8.8-148: Lower band edge emission at 5150 MHz, channel 36, 802.11n HT20, cho, Average

Section 8
Test name
Specification

Testing data
 FCC 15.407(b) and RSS-247 6.2 Undesirable (unwanted) emissions
 FCC Part 15 Subpart E and RSS-247, Issue 1

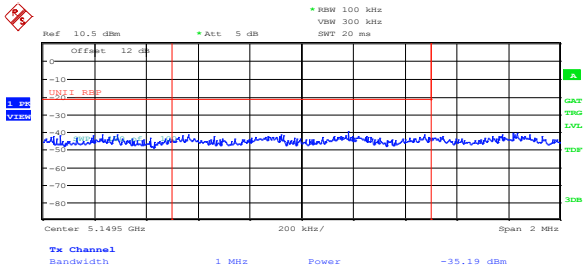

Date: 13.DEC.2016 09:43:25

Figure 8.8-149: Lower band edge emission at 5150 MHz, channel 38, 802.11n HT40, ch0, Peak

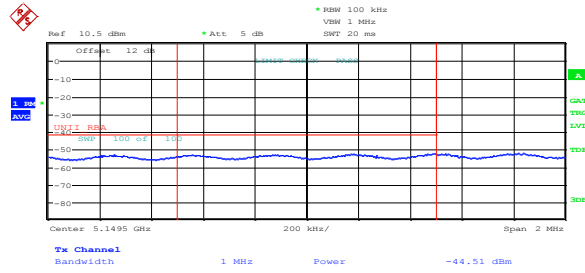

Date: 13.DEC.2016 09:43:57

Figure 8.8-150: Lower band edge emission at 5150 MHz, channel 38, 802.11n HT40, ch0, Average

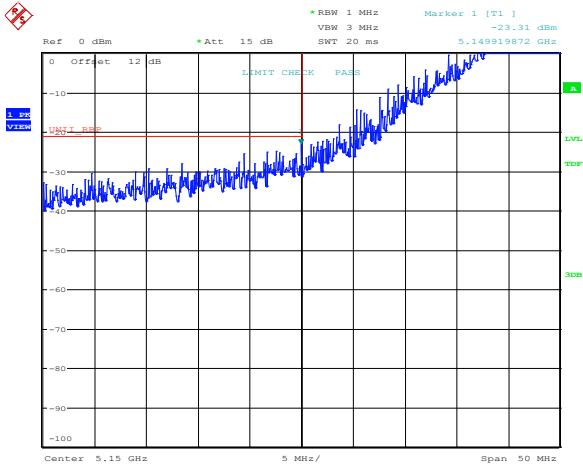

Date: 6.DEC.2016 16:56:04

Figure 8.8-151: Lower band edge emission at 5150 MHz, channel 36, 802.11a, ch1, Peak

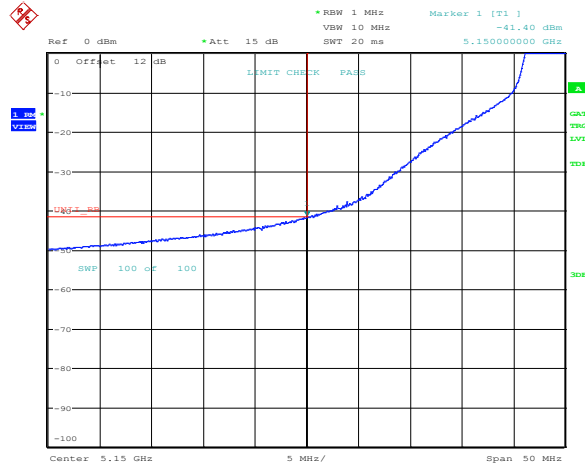

Date: 6.DEC.2016 16:51:34

Figure 8.8-152: Lower band edge emission at 5150 MHz, channel 36, 802.11a, ch1, Average

Section 8
Test name
Specification

Testing data
 FCC 15.407(b) and RSS-247 6.2 Undesirable (unwanted) emissions
 FCC Part 15 Subpart E and RSS-247, Issue 1

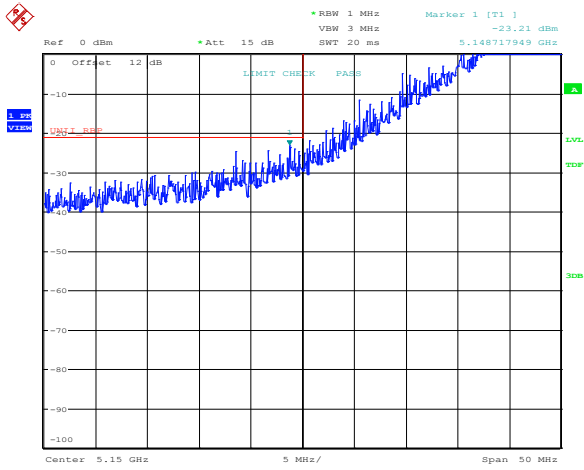

Date: 6.DEC.2016 16:59:27

Figure 8.8-153: Lower band edge emission at 5150 MHz, channel 36, 802.11n HT20, ch1, Peak

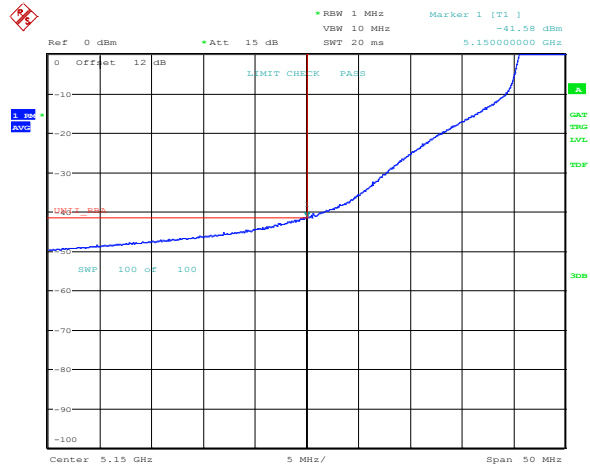

Date: 6.DEC.2016 17:00:27

Figure 8.8-154: Lower band edge emission at 5150 MHz, channel 36, 802.11n HT20, ch1, Average

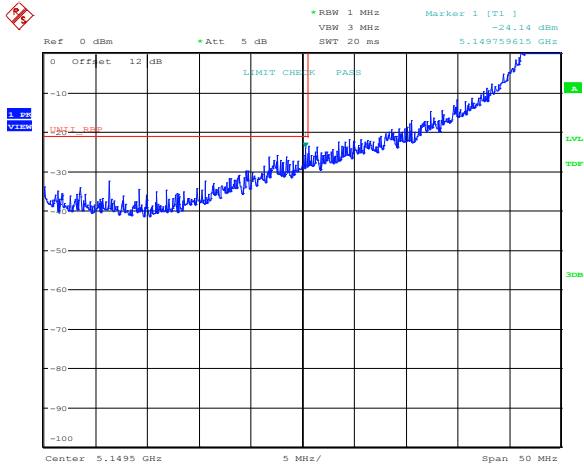

Date: 7.DEC.2016 09:47:31

Figure 8.8-155: Lower band edge emission at 5150 MHz, channel 38, 802.11n HT40, ch1, Peak

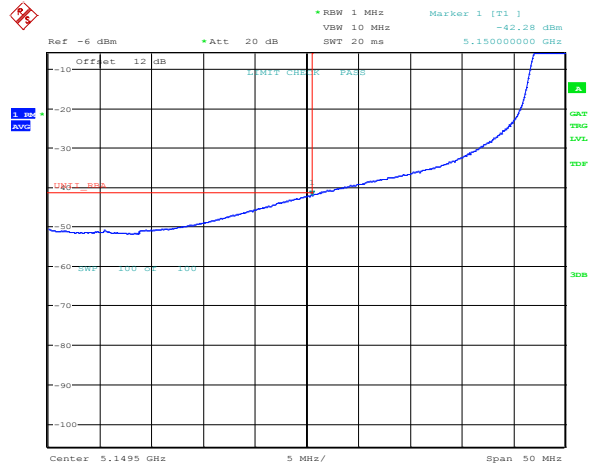

Date: 6.DEC.2016 17:14:24

Figure 8.8-156: Lower band edge emission at 5150 MHz, channel 38, 802.11n HT40, ch1, Average

Section 8
Test name
Specification

Testing data
 FCC 15.407(b) and RSS-247 6.2 Undesirable (unwanted) emissions
 FCC Part 15 Subpart E and RSS-247, Issue 1

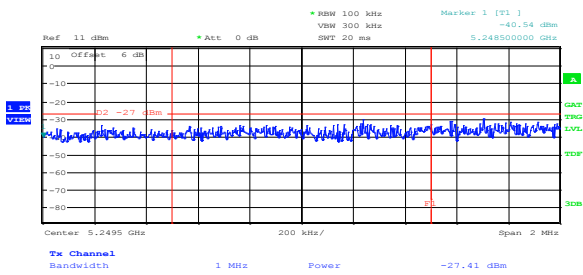

Date: 12.JAN.2017 10:54:52

Figure 8.8-157: Lower band edge emission at 5250 MHz, channel 52, 802.11a, cho, ISED only

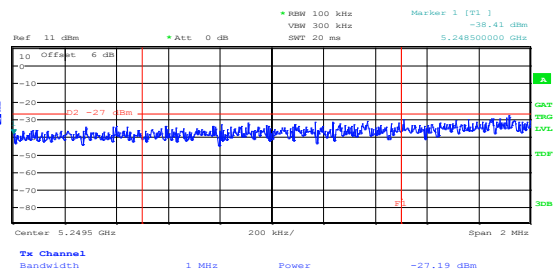

Date: 12.JAN.2017 10:52:25

Figure 8.8-158: Lower band edge emission at 5250 MHz, channel 52, 802.11n HT20, cho, ISED only

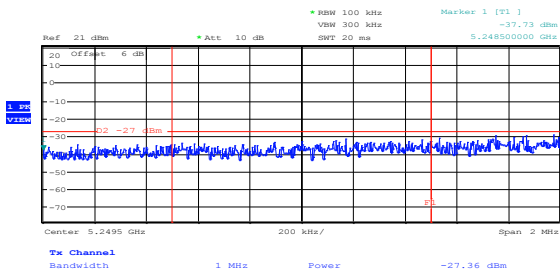

Date: 12.JAN.2017 10:49:37

Figure 8.8-159: Lower band edge emission at 5250 MHz, channel 54, 802.11n HT40, cho, ISED only

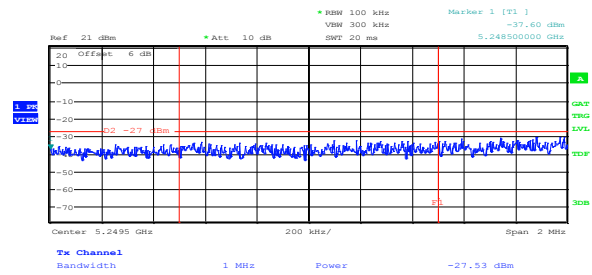

Date: 12.JAN.2017 10:45:57

Figure 8.8-160: Lower band edge emission at 5250 MHz, channel 52, 802.11a, ch1, ISED only

Section 8
Test name
Specification

Testing data
 FCC 15.407(b) and RSS-247 6.2 Undesirable (unwanted) emissions
 FCC Part 15 Subpart E and RSS-247, Issue 1

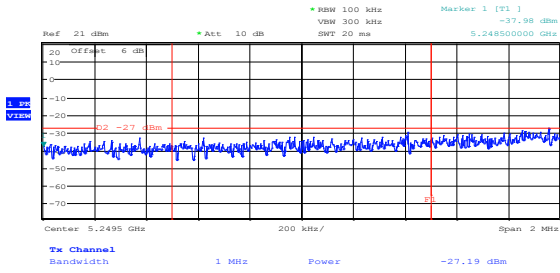

Date: 12.JAN.2017 10:22:05

Figure 8.8-161: Lower band edge emission at 5250 MHz, channel 52, 802.11n HT20, ch1, ISED only

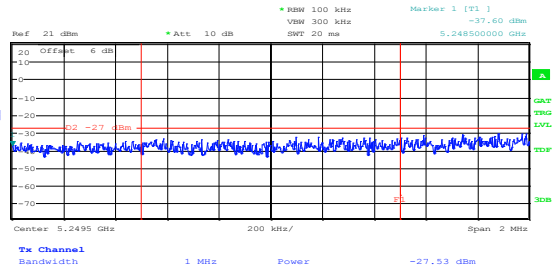

Date: 12.JAN.2017 10:45:57

Figure 8.8-162: Lower band edge emission at 5250 MHz, channel 54, 802.11n HT40, ch1, ISED only

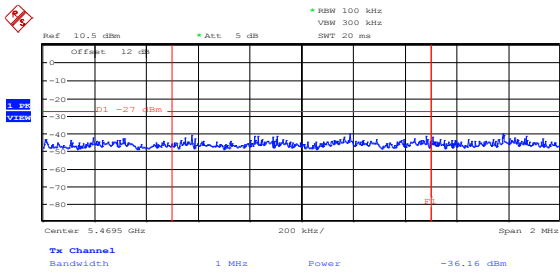

Date: 13.DEC.2016 09:29:14

Figure 8.8-163: Lower band edge emission at 5470 MHz, channel 100, 802.11a, cho

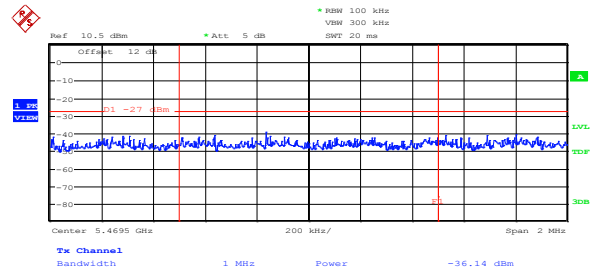

Date: 13.DEC.2016 09:28:31

Figure 8.8-164: Lower band edge emission at 5470 MHz, channel 100, 802.11n HT20, cho

Section 8
Test name
Specification

Testing data
 FCC 15.407(b) and RSS-247 6.2 Undesirable (unwanted) emissions
 FCC Part 15 Subpart E and RSS-247, Issue 1

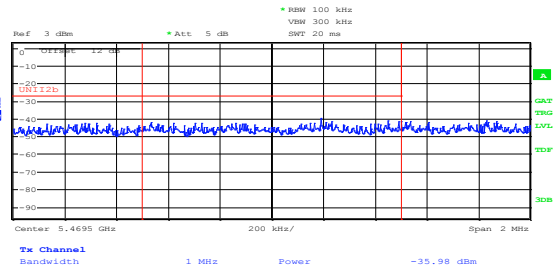
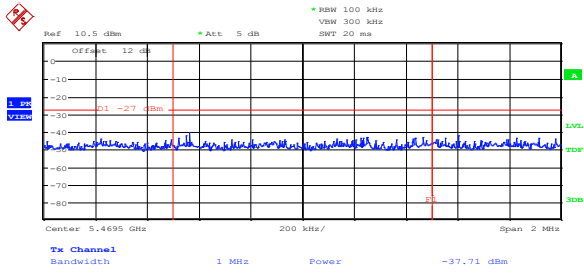

Date: 13.DEC.2016 09:27:24

Date: 9.JAN.2017 13:29:00

Figure 8.8-165: Lower band edge emission at 5470 MHz, channel 102, 802.11n HT40, cho

Figure 8.8-166: Lower band edge emission at 5470 MHz, channel 100, 802.11a, ch1

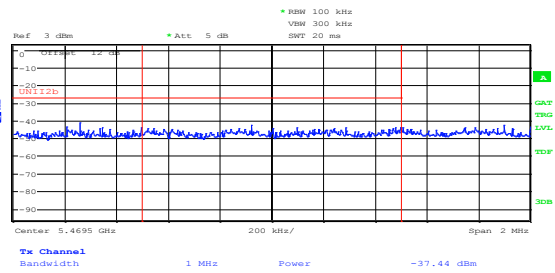
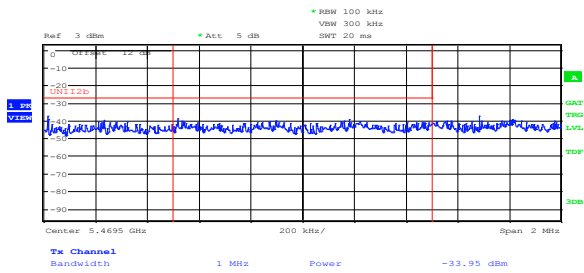

Date: 9.JAN.2017 13:32:17

Date: 9.JAN.2017 13:33:15

Figure 8.8-167: Lower band edge emission at 5470 MHz, channel 100, 802.11n HT20, ch1

Figure 8.8-168: Lower band edge emission at 5470 MHz, channel 102, 802.11n HT40, ch1

Section 8
Test name
Specification

Testing data
 FCC 15.407(b) and RSS-247 6.2 Undesirable (unwanted) emissions
 FCC Part 15 Subpart E and RSS-247, Issue 1

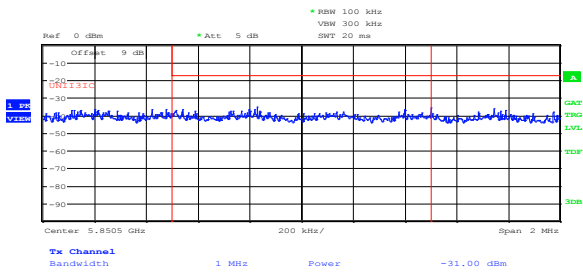

Date: 9.JAN.2017 11:20:47

Figure 8.8-169: Upper band edge emission at 5850 MHz, channel 165, 802.11a, cho

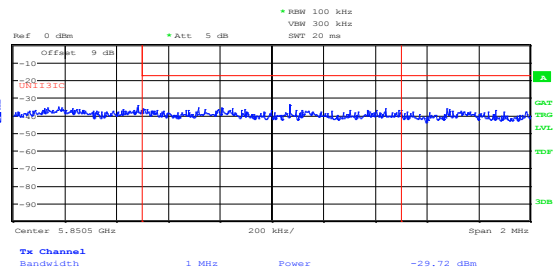

Date: 9.JAN.2017 11:19:22

Figure 8.8-170: Upper band edge emission at 5850 MHz, channel 165, 802.11n HT20, cho

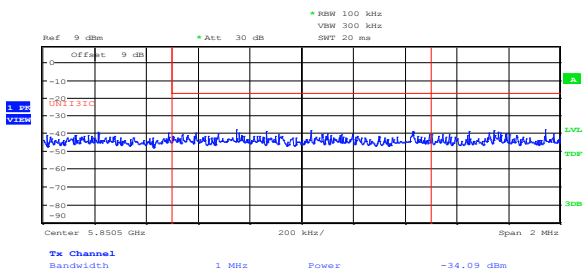

Date: 9.JAN.2017 11:05:53

Figure 8.8-171: Upper band edge emission at 5850 MHz, channel 159, 802.11n HT40, cho



Date: 9.JAN.2017 11:42:45

Figure 8.8-172: Upper band edge emission at 5850 MHz, channel 165, 802.11a, ch1

Section 8
Test name
Specification

Testing data
 FCC 15.407(b) and RSS-247 6.2 Undesirable (unwanted) emissions
 FCC Part 15 Subpart E and RSS-247, Issue 1



Date: 9.JAN.2017 11:44:29

Figure 8.8-173: Upper band edge emission at 5850 MHz, channel 165, 802.11n HT20, ch1

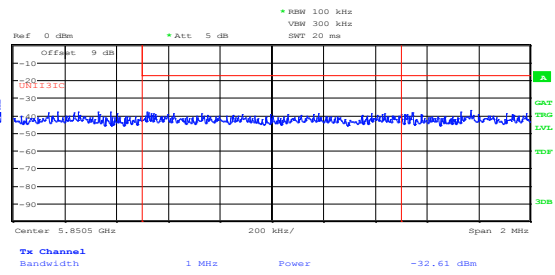

Date: 9.JAN.2017 11:45:31

Figure 8.8-174: Upper band edge emission at 5850 MHz, channel 159, 802.11n HT40, ch1

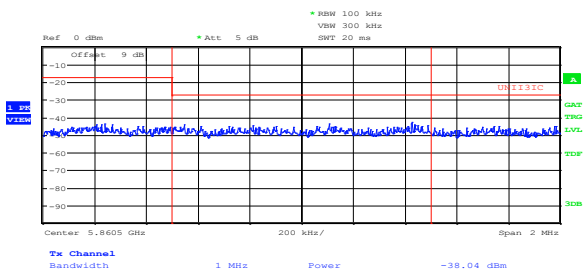

Date: 9.JAN.2017 11:21:07

Figure 8.8-175: Upper band edge emission at 5860 MHz, channel 165, 802.11a, cho

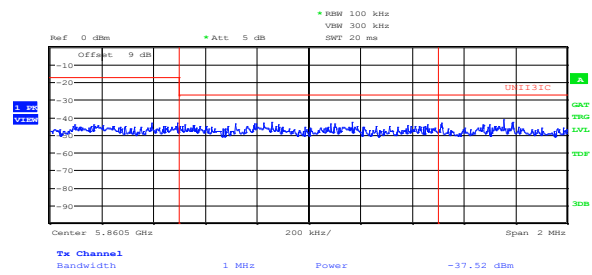

Date: 9.JAN.2017 11:18:59

Figure 8.8-176: Upper band edge emission at 5860 MHz, channel 165, 802.11n HT20, cho

Section 8
Test name
Specification

Testing data
 FCC 15.407(b) and RSS-247 6.2 Undesirable (unwanted) emissions
 FCC Part 15 Subpart E and RSS-247, Issue 1

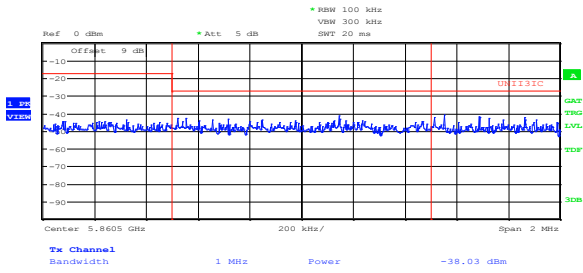

Date: 9.JAN.2017 11:17:21

Figure 8.8-177: Upper band edge emission at 5860 MHz, channel 159, 802.11n HT40, cho

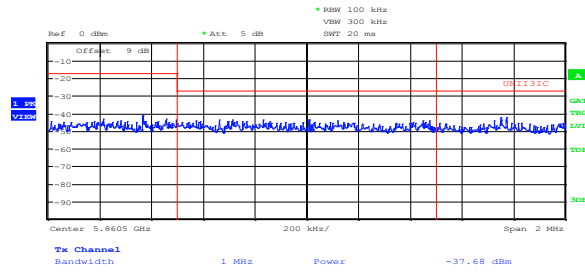

Date: 9.JAN.2017 11:43:12

Figure 8.8-178: Upper band edge emission at 5860 MHz, channel 165, 802.11a, ch1

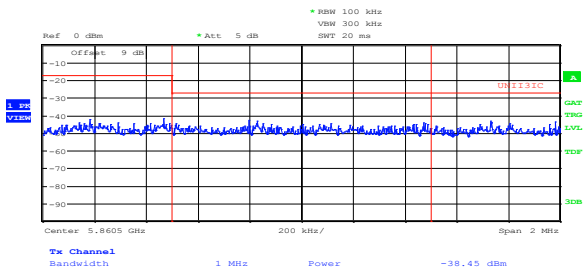

Date: 9.JAN.2017 11:44:06

Figure 8.8-179: Upper band edge emission at 5860 MHz, channel 165, 802.11n HT20, ch1

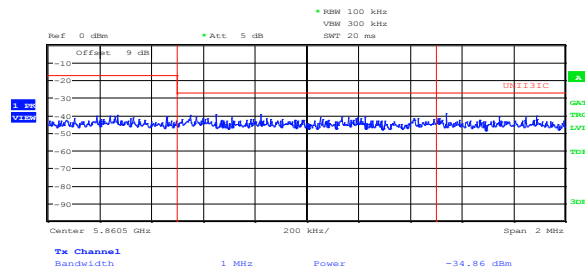

Date: 9.JAN.2017 11:46:01

Figure 8.8-180: Upper band edge emission at 5860 MHz, channel 159, 802.11n HT40, ch1

Section 8
Test name
Specification

Testing data
 FCC 15.407(b) and RSS-247 6.2 Undesirable (unwanted) emissions
 FCC Part 15 Subpart E and RSS-247, Issue 1



Date: 9.JAN.2017 14:27:13

Figure 8.8-181: Upper band edge emission at 5250 MHz (ISED only), channel 48, 802.11a, cho – reference fundamental

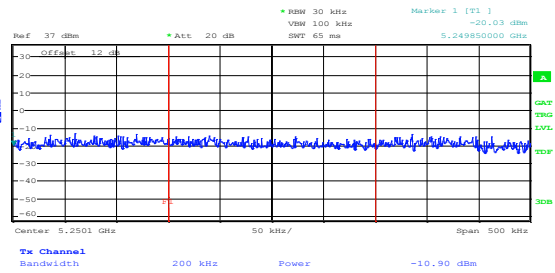

Date: 9.JAN.2017 14:27:53

Figure 8.8-182: Upper band edge emission at 5250 MHz (ISED only), channel 48, 802.11a, cho
 $17.25 - (-10.90) = 28.15$ dB. Minimum limit is 26 dBc.



Date: 9.JAN.2017 14:29:15

Figure 8.8-183: Upper band edge emission at 5250 MHz (ISED only), channel 48, 802.11n HT20, cho – reference fundamental

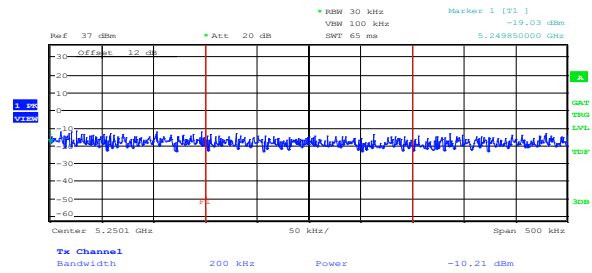

Date: 9.JAN.2017 14:28:42

Figure 8.8-184: Upper band edge emission at 5250 MHz (ISED only), channel 48, 802.11n HT20, cho
 $18.21 - (-10.21) = 28.42$ dB. Minimum limit is 26 dBc.

Section 8
Test name
Specification

Testing data
 FCC 15.407(b) and RSS-247 6.2 Undesirable (unwanted) emissions
 FCC Part 15 Subpart E and RSS-247, Issue 1

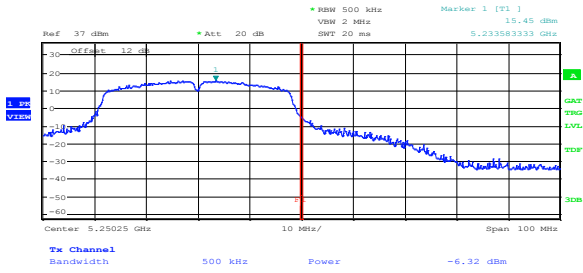

Date: 9.JAN.2017 14:23:40

Figure 8.8-185: Upper band edge emission at 5250 MHz (ISED only), channel 46, 802.11n HT40, cho – reference fundamental

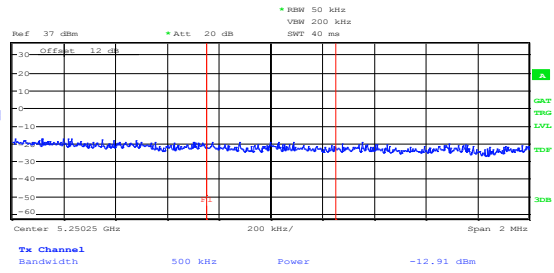

Date: 9.JAN.2017 14:23:01

Figure 8.8-186: Upper band edge emission at 5250 MHz (ISED only), channel 46, 802.11n HT40, cho. $15.45 - (-12.91) = 28.36$ dBc. Minimum limit is 26 dBc.



Date: 9.JAN.2017 14:13:23

Figure 8.8-187: Upper band edge emission at 5250 MHz (ISED only), channel 48, 802.11a, ch1 – reference fundamental

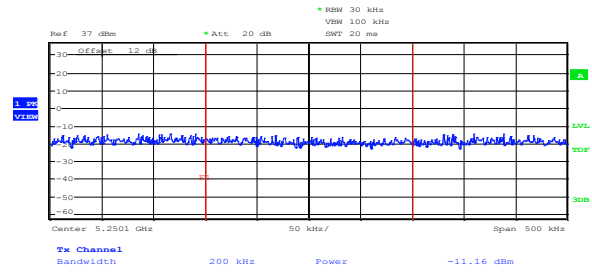

Date: 9.JAN.2017 14:12:05

Figure 8.8-188: Upper band edge emission at 5250 MHz (ISED only), channel 48, 802.11a, ch1 $16.46 - (-11.16) = 27.62$ dBc. Minimum limit is 26 dBc.

Section 8
Test name
Specification

Testing data
 FCC 15.407(b) and RSS-247 6.2 Undesirable (unwanted) emissions
 FCC Part 15 Subpart E and RSS-247, Issue 1



Date: 9.JAN.2017 14:15:00

Figure 8.8-189: Upper band edge emission at 5250 MHz (ISED only), channel 48, 802.11n HT20, ch1 – reference fundamental

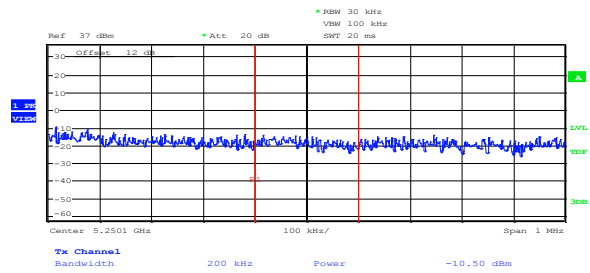

Date: 9.JAN.2017 14:15:44

Figure 8.8-190: Upper band edge emission at 5250 MHz (ISED only), channel 48, 802.11n HT20, ch1
 $17.14 - (-10.50) = 27.64$ dBc. Minimum limit is 26 dBc.



Date: 9.JAN.2017 14:16:55

Figure 8.8-191: Upper band edge emission at 5250 MHz (ISED only), channel 46, 802.11n HT40, ch1 – reference fundamental

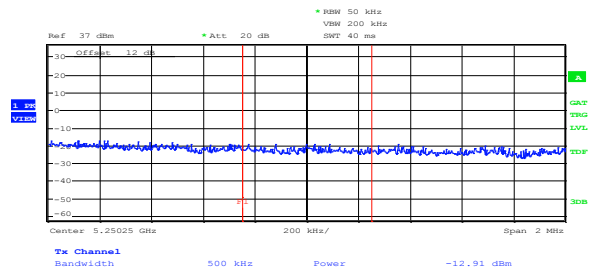

Date: 9.JAN.2017 14:23:01

Figure 8.8-192: Upper band edge emission at 5250 MHz (ISED only), channel 46, 802.11n HT40, ch1
 $15.50 - (-12.91) = 28.41$ dBc. Minimum limit is 26 dBc.

Section 8
Test name
Specification

Testing data
 FCC 15.407(b) and RSS-247 6.2 Undesirable (unwanted) emissions
 FCC Part 15 Subpart E and RSS-247, Issue 1

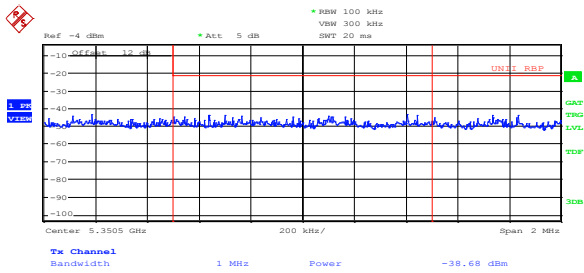

Date: 13.DEC.2016 10:02:04

Figure 8.8-193: Upper band edge emission at 5350 MHz, channel 64, 802.11a, cho, Peak

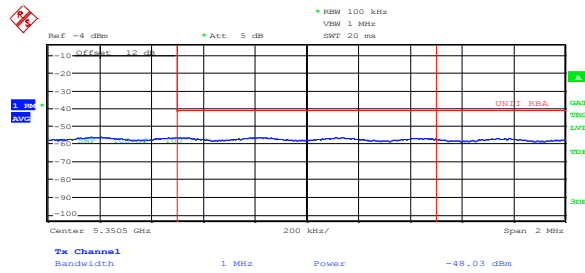

Date: 13.DEC.2016 10:01:39

Figure 8.8-194: Upper band edge emission at 5350 MHz, channel 64, 802.11a, cho, Average

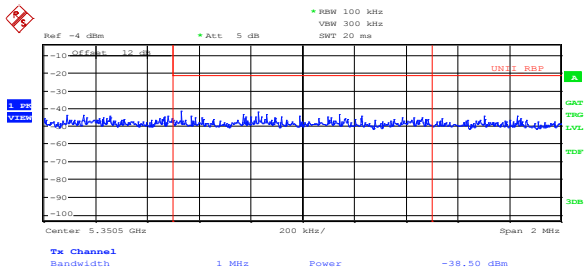

Date: 13.DEC.2016 09:56:06

Figure 8.8-195: Upper band edge emission at 5350 MHz, channel 64, 802.11n HT20, cho, Peak

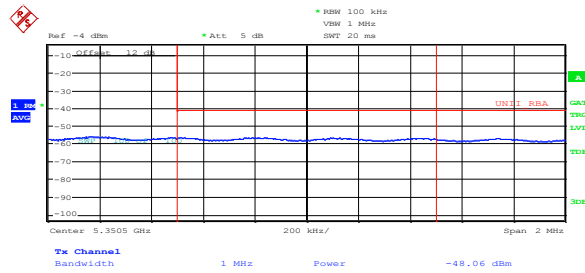

Date: 13.DEC.2016 09:56:57

Figure 8.8-196: Upper band edge emission at 5350 MHz, channel 64, 802.11n HT20, cho, Average

Section 8
Test name
Specification

Testing data
 FCC 15.407(b) and RSS-247 6.2 Undesirable (unwanted) emissions
 FCC Part 15 Subpart E and RSS-247, Issue 1

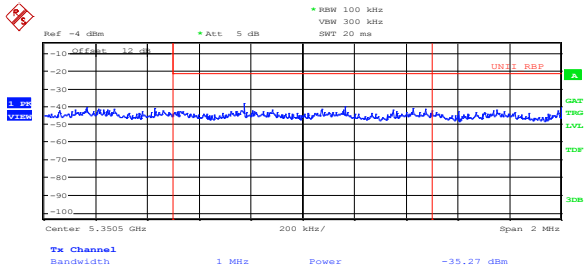

Date: 13.DEC.2016 09:51:20

Figure 8.8-197: Upper band edge emission at 5350 MHz, channel 62, 802.11n HT40, cho, Peak

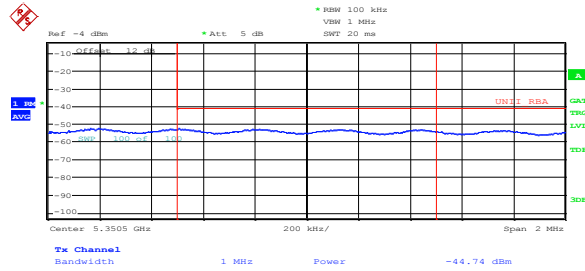

Date: 13.DEC.2016 09:50:38

Figure 8.8-198: Upper band edge emission at 5350 MHz, channel 62, 802.11n HT40, cho, Average

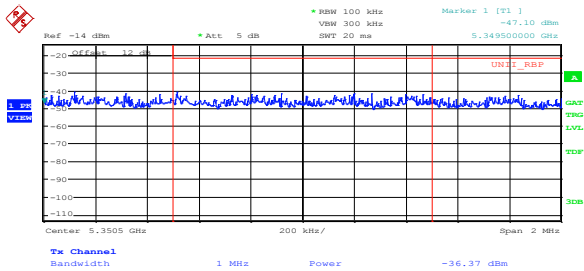

Date: 7.DEC.2016 11:04:00

Figure 8.8-199: Upper band edge emission at 5350 MHz, channel 64, 802.11a, ch1, Peak

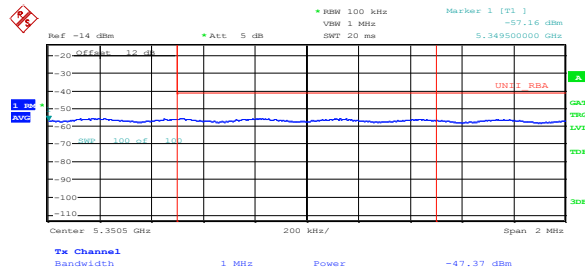

Date: 7.DEC.2016 11:03:20

Figure 8.8-200: Upper band edge emission at 5350 MHz, channel 64, 802.11a, ch1, Average

Section 8
Test name
Specification

Testing data
FCC 15.407(b) and RSS-247 6.2 Undesirable (unwanted) emissions
FCC Part 15 Subpart E and RSS-247, Issue 1

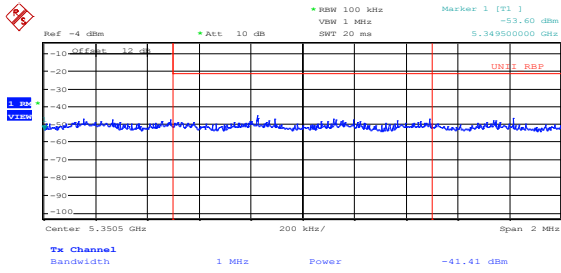

Date: 7.DEC.2016 10:04:40

Figure 8.8-201: Upper band edge emission at 5350 MHz, channel 64, 802.11n HT20, ch1, Peak

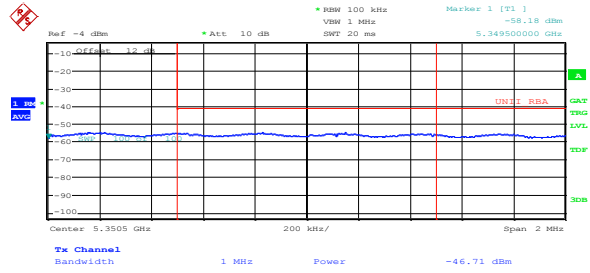

Date: 7.DEC.2016 10:03:17

Figure 8.8-202: Upper band edge emission at 5350 MHz, channel 64, 802.11n HT20, ch1, Average

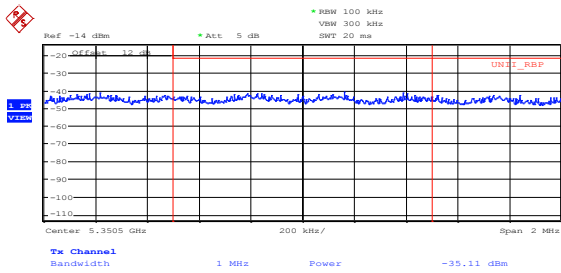

Date: 7.DEC.2016 11:07:11

Figure 8.8-203: Upper band edge emission at 5350 MHz, channel 62, 802.11n HT40, ch1, Peak

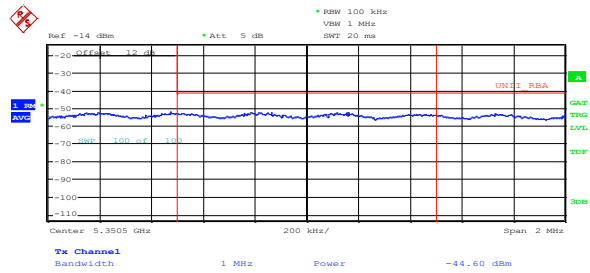

Date: 7.DEC.2016 11:06:21

Figure 8.8-204: Upper band edge emission at 5350 MHz, channel 62, 802.11n HT40, ch1, Average

Section 8
Test name
Specification

Testing data
 FCC 15.407(b) and RSS-247 6.2 Undesirable (unwanted) emissions
 FCC Part 15 Subpart E and RSS-247, Issue 1

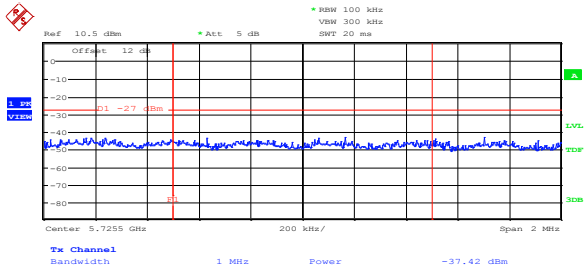

Date: 13.DEC.2016 09:25:26

Figure 8.8-205: Upper band edge emission at 5725 MHz, channel 140, 802.11a, cho

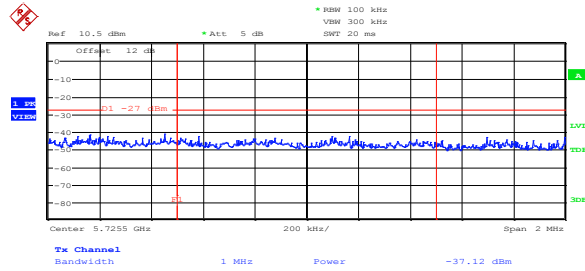

Date: 13.DEC.2016 09:24:28

Figure 8.8-206: Upper band edge emission at 5725 MHz, channel 140, 802.11n HT20, cho

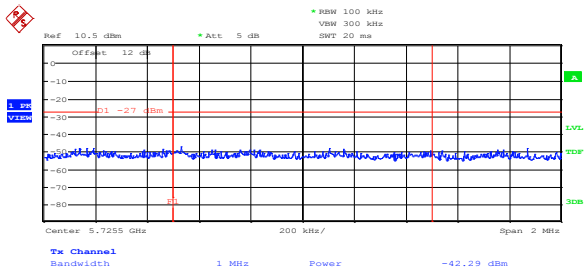

Date: 13.DEC.2016 09:26:17

Figure 8.8-207: Upper band edge emission at 5725 MHz, channel 134, 802.11n HT40, cho

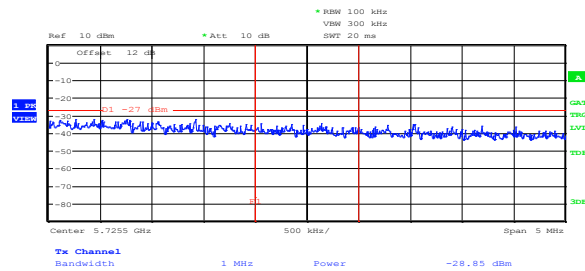

Date: 11.JAN.2017 11:28:38

Figure 8.8-208: Upper band edge emission at 5725 MHz, channel 134, 802.11a, ch1

Section 8
Test name
Specification

Testing data
 FCC 15.407(b) and RSS-247 6.2 Undesirable (unwanted) emissions
 FCC Part 15 Subpart E and RSS-247, Issue 1

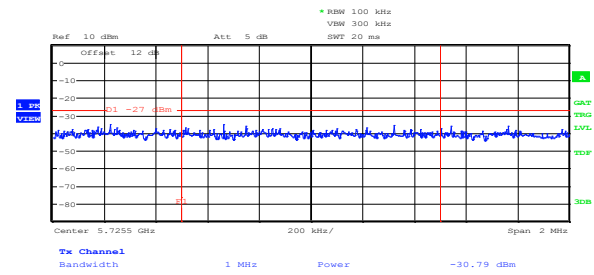
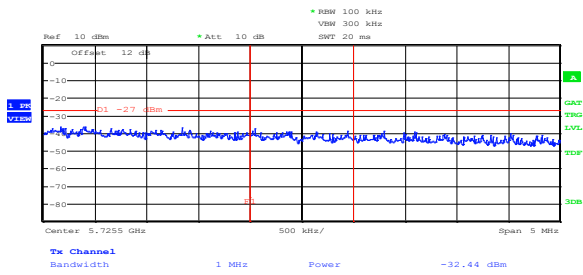

Date: 11.JAN.2017 11:32:30

Date: 11.JAN.2017 11:14:09

Figure 8.8-209: Upper band edge emission at 5725 MHz, channel 140, 802.11n HT20, ch1

Figure 8.8-210: Upper band edge emission at 5725 MHz, channel 134, 802.11n HT40, ch1

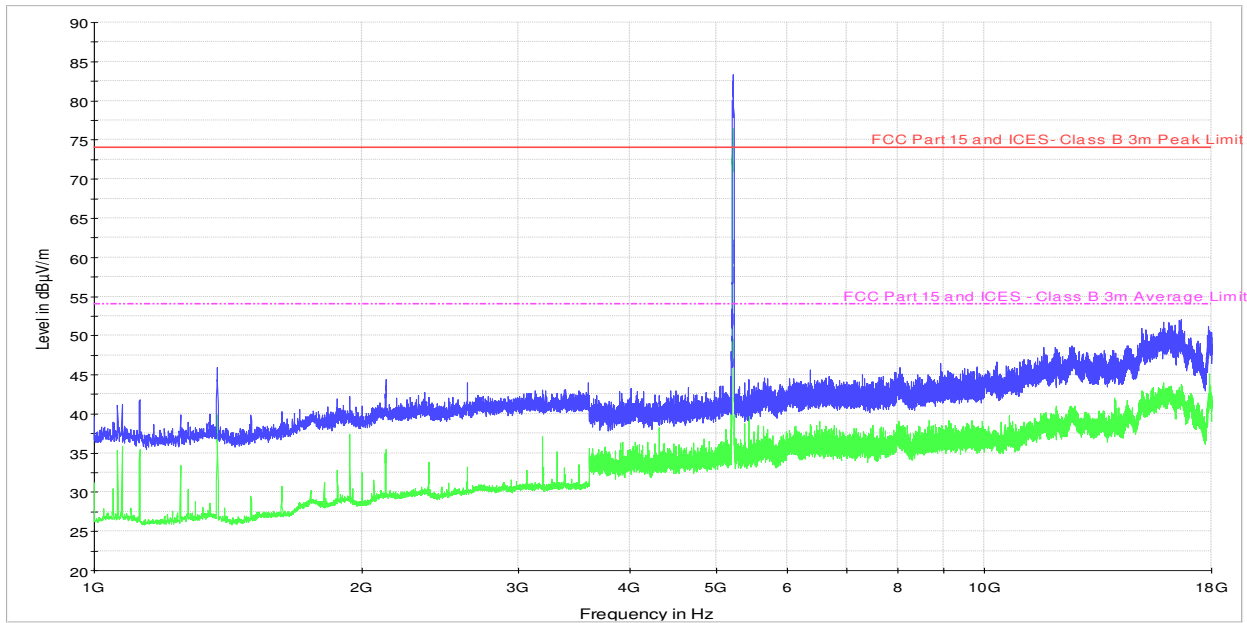

Figure 8.8-211: Spurious radiation outside restricted bands sample plot, 5150–5250 GHz

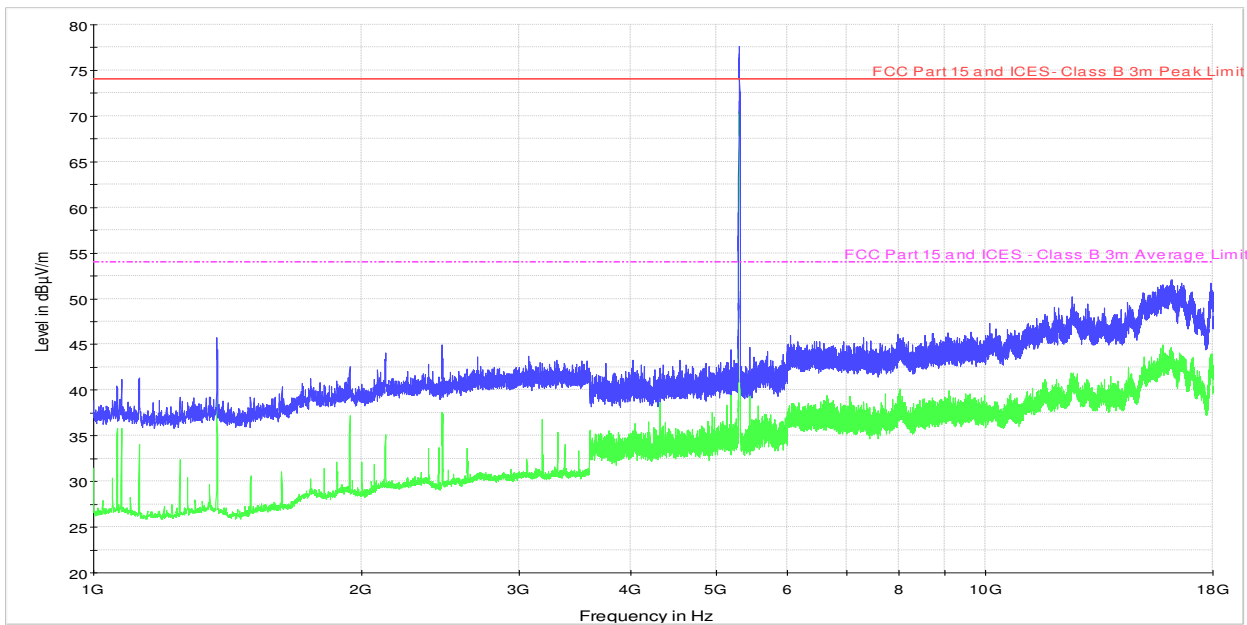

Figure 8.8-212: Spurious radiation outside restricted bands sample plot, 5250–5350 GHz

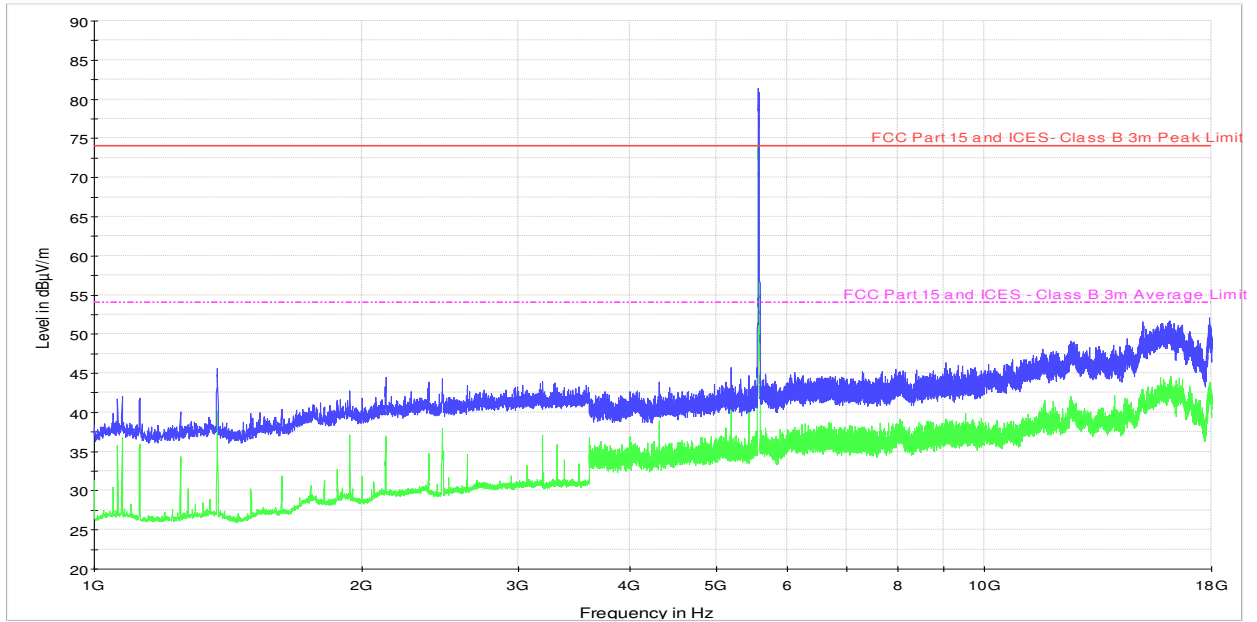

Figure 8.8-213: Spurious radiation outside restricted bands sample plot, 5470–5725 GHz

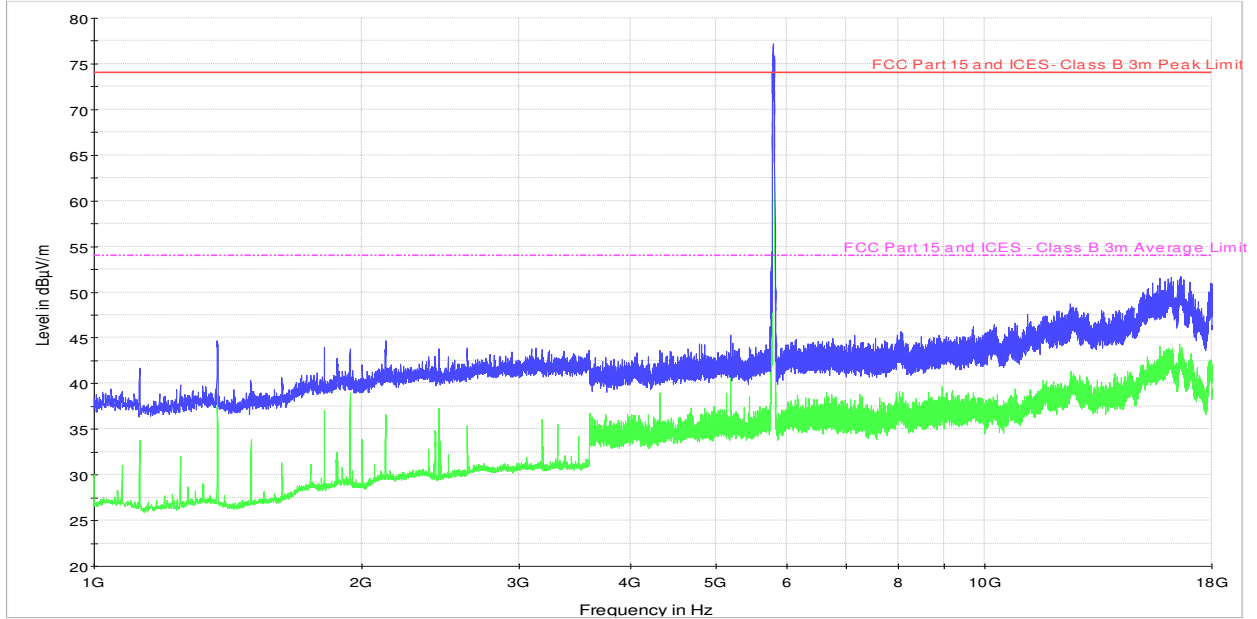

Figure 8.8-214: Spurious radiation outside restricted bands sample plot, 5725–5850 GHz

8.9 FCC 15.207(a) and RSS-Gen 8.8 AC power line conducted emissions limits

8.9.1 Definitions and limits

FCC §15.407(6)(b):

Any U-NII devices using an AC power line are required to comply also with the conducted limits set forth in §15.207

FCC §15.207(a):

Except as shown in paragraphs (b) and (c) of this section, for an intentional radiator that is designed to be connected to the public utility (AC) power line, the radio frequency voltage that is conducted back onto the AC power line on any frequency or frequencies, within the band 150 kHz to 30 MHz, shall not exceed the limits in the following table, as measured using a 50 μ H/50 Ω line impedance stabilization network (LISN). Compliance with the provisions of this paragraph shall be based on the measurement of the radio frequency voltage between each power line and ground at the power terminal. The lower limit applies at the boundary between the frequency ranges.

IC:

A radio apparatus that is designed to be connected to the public utility (AC) power line shall ensure that the radio frequency voltage, which is conducted back onto the AC power line on any frequency or frequencies within the band 150 kHz to 30 MHz, shall not exceed the limits in table below.

Unless the requirements applicable to a given device state otherwise, for any radio apparatus equipped to operate from the public utility AC power supply either directly or indirectly (such as with a battery charger), the radio frequency voltage of emissions conducted back onto the AC power lines in the frequency range of 0.15 MHz to 30 MHz shall not exceed the limits shown in table below. The more stringent limit applies at the frequency range boundaries.

Table 8.9-1: Conducted emissions limit

Frequency of emission (MHz)	Conducted limit (dB μ V)	
	Quasi-peak	Average**
0.15–0.5	66 to 56*	56 to 46*
0.5–5	56	46
5–30	60	50

Note: * - The level decreases linearly with the logarithm of the frequency.

** - A linear average detector is required.

8.9.2 Test summary

Test date	January 11, 2017	Temperature	22 °C
Test engineer	Andrey Adelberg	Air pressure	1010 mbar
Verdict	Pass	Relative humidity	33 %

8.9.3 Observations, settings and special notes

The EUT was set up as tabletop configuration.

The spectral scan has been corrected with transducer factors (i.e. cable loss, LISN factors, and attenuators) for determination of compliance.

A preview measurement was generated with the receiver in continuous scan mode. Emissions detected within 6 dB or above limit were re-measured with the appropriate detector against the correlating limit and recorded as the final measurement.

Receiver settings for preview measurements:

Resolution bandwidth	9 kHz
Video bandwidth	30 kHz
Detector mode	Peak and Average
Trace mode	Max Hold
Measurement time	100 ms

Receiver settings for final measurements:

Resolution bandwidth	9 kHz
Video bandwidth	30 kHz
Detector mode	Quasi-Peak and Average
Trace mode	Max Hold
Measurement time	100 ms

8.9.4 Test data

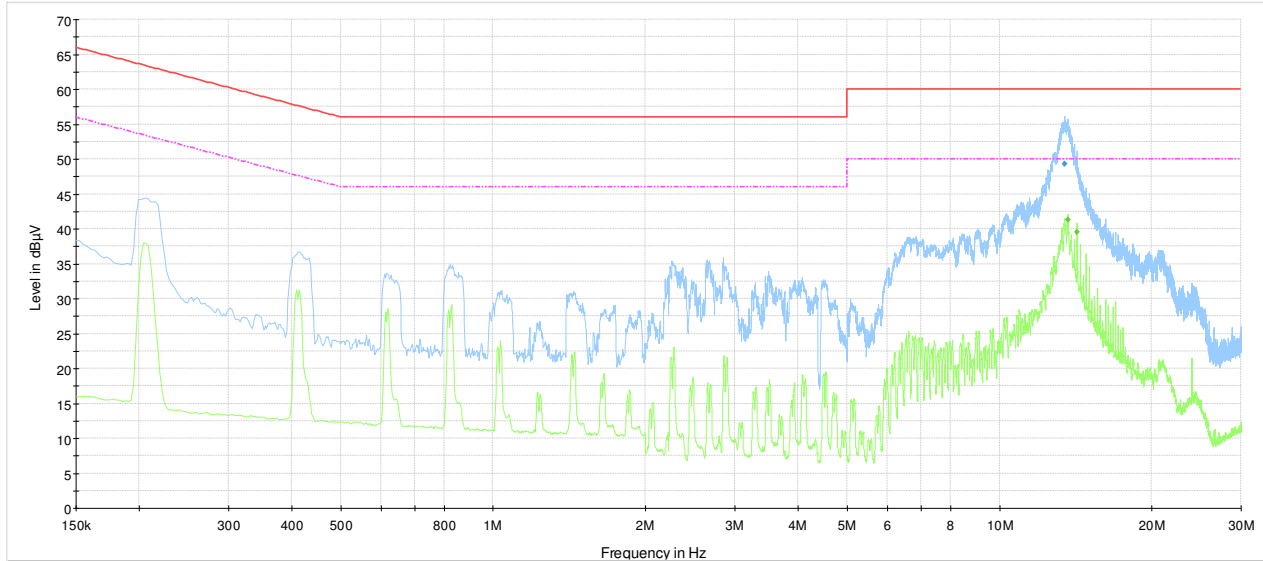

- Conducted emissions on phase line
- Preview Result 2-AVG
- Preview Result 1-PK+
- CISPR 22 Mains Q-Peak Class B Limit
- CISPR 22 Mains Average Class B Limit
- Final_Result QPK
- Final_Result CAV

Plot 8.9-1: Conducted emissions on phase line, 24 V_{DC} PS

Table 8.9-2: Quasi-Peak conducted emissions results on phase line

Frequency, MHz	Q-Peak result, dBµV	Limit, dBµV	Margin, dB	Meas. Time, ms	Bandwidth, kHz	Filter	Correction, dB
13.458250	49.26	60.00	10.74	100	9	ON	10.3

Note: 43.5 dBµV = 23.2 dBµV (receiver reading) + 10.1 dB (LISN factor IL) + 0.2 dB (cable loss) + 10 dB (attenuator)

Table 8.9-3: Average conducted emissions results on phase line

Frequency, MHz	CAverage result, dBµV	Limit, dBµV	Margin, dB	Meas. Time, ms	Bandwidth, kHz	Filter	Correction, dB
13.654000	41.35	50.00	8.65	100	9	ON	10.3
14.239000	39.58	50.00	10.42	100	9	ON	10.3

Sample calculation:

Correction factor (dB) = LISN factor IL (dB) + cable loss (dB) + attenuator (dB)

Result (dBµV) = XX dBµV (reading from receiver) + XX dB (Correction factor)

Example:

43.5 dBµV = 23.2 dBµV (receiver reading) + 10.1 dB (LISN factor IL) + 0.2 dB (cable loss) + 10 dB (attenuator)

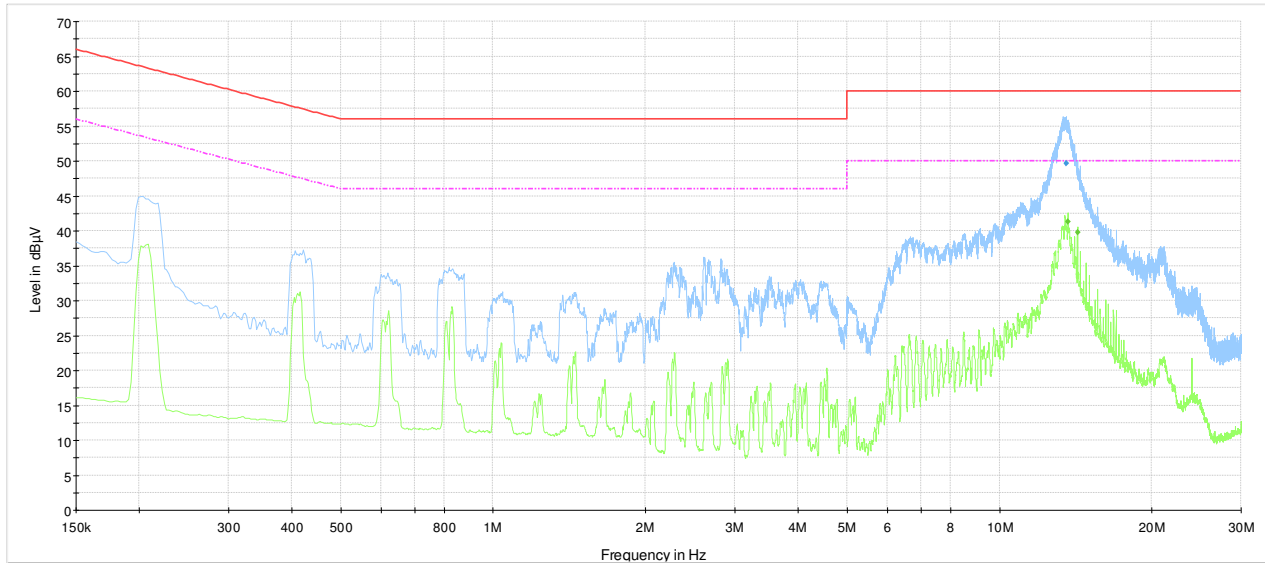

Conducted emissions on neutral line
 Preview Result 2-AVG
 Preview Result 1-PK+
 CISPR 22 Mains Q-Peak Class B Limit
 CISPR 22 Mains Average Class B Limit
 Final_Result QPK
 Final_Result CAV

Plot 8.9-2: Conducted emissions on neutral line, 24 V_{dc} PS

Table 8.9-4: Quasi-Peak conducted emissions results on neutral line

Frequency, MHz	Q-Peak result, dBµV	Limit, dBµV	Margin, dB	Meas. Time, ms	Bandwidth, kHz	Filter	Correction, dB
13.528000	49.68	60.00	10.32	100	9	ON	10.4

Note: 43.5 dBµV = 23.2 dBµV (receiver reading) + 10.1 dB (LISN factor IL) + 0.2 dB (cable loss) + 10 dB (attenuator)

Table 8.9-5: Average conducted emissions results on neutral line

Frequency, MHz	CAverage result, dBµV	Limit, dBµV	Margin, dB	Meas. Time, ms	Bandwidth, kHz	Filter	Correction, dB
13.667500	41.27	50.00	8.73	100	9	ON	10.3
14.252500	39.72	50.00	10.28	100	9	ON	10.3

Sample calculation:

Correction factor (dB) = LISN factor IL (dB) + cable loss (dB) + attenuator (dB)

Result (dBµV) = XX dBµV (reading from receiver) + XX dB (Correction factor)

Example:

43.5 dBµV = 23.2 dBµV (receiver reading) + 10.1 dB (LISN factor IL) + 0.2 dB (cable loss) + 10 dB (attenuator)

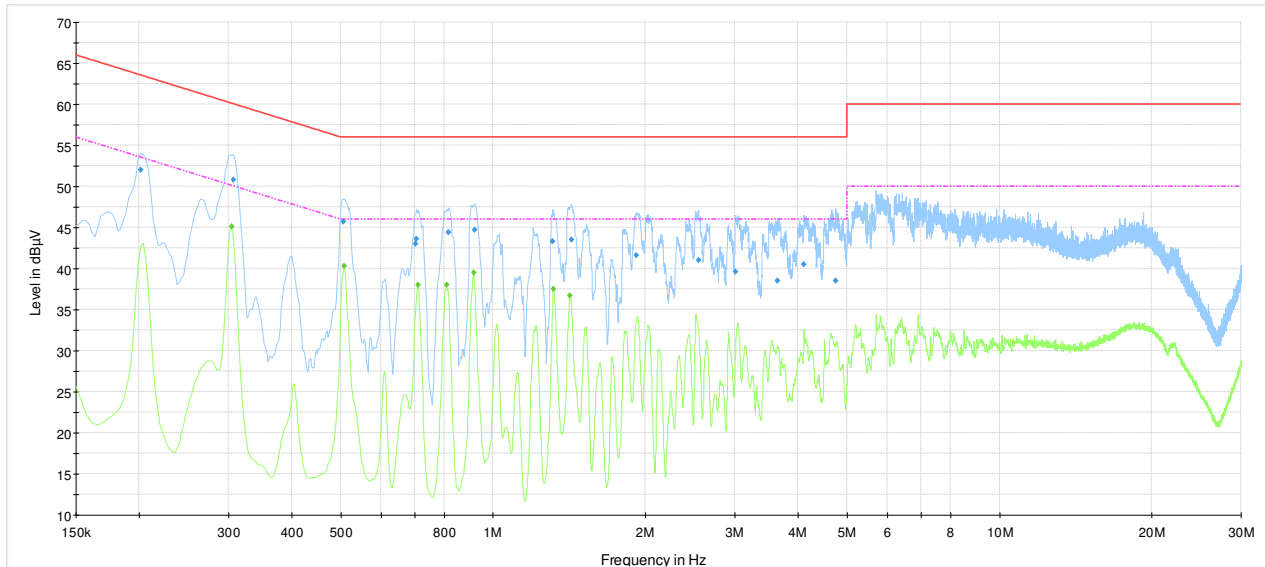

- Conducted emissions on phase line
- Preview Result 2-AVG
- Preview Result 1-PK+
- CISPR 22 Mains Q-Peak Class B Limit
- CISPR 22 Mains Average Class B Limit
- Final_Result QPK
- Final_Result CAV

Plot 8.9-3: Conducted emissions on phase line, 48 V_{DC} PS



Table 8.9-6: Quasi-Peak conducted emissions results on phase line

Frequency, MHz	Q-Peak result, dB μ V	Limit, dB μ V	Margin, dB	Meas. Time, ms	Bandwidth, kHz	Filter	Correction, dB
0.201750	52.03	63.54	11.51	100	9	ON	9.9
0.307500	50.77	60.04	9.27	100	9	ON	9.8
0.505500	45.71	56.00	10.29	100	9	ON	10.0
0.703500	42.99	56.00	13.01	100	9	ON	9.9
0.705750	43.60	56.00	12.40	100	9	ON	9.9
0.816000	44.38	56.00	11.62	100	9	ON	9.9
0.919500	44.71	56.00	11.29	100	9	ON	9.9
1.313250	43.30	56.00	12.70	100	9	ON	9.9
1.428000	43.47	56.00	12.53	100	9	ON	9.9
1.920750	41.60	56.00	14.40	100	9	ON	9.9
2.544000	41.01	56.00	14.99	100	9	ON	9.9
3.009750	39.59	56.00	16.41	100	9	ON	9.9
3.646500	38.48	56.00	17.52	100	9	ON	9.9
4.110000	40.53	56.00	15.47	100	9	ON	9.9
4.749000	38.54	56.00	17.46	100	9	ON	10.0

Note: 43.5 dB μ V = 23.2 dB μ V (receiver reading) + 10.1 dB (LISN factor IL) + 0.2 dB (cable loss) + 10 dB (attenuator)

Table 8.9-7: Average conducted emissions results on phase line

Frequency, MHz	CAverage result, dB μ V	Limit, dB μ V	Margin, dB	Meas. Time, ms	Bandwidth, kHz	Filter	Correction, dB
0.305250	45.13	50.10	4.97	100	9	ON	9.8
0.507750	40.35	46.00	5.65	100	9	ON	10.0
0.710250	38.00	46.00	8.00	100	9	ON	9.9
0.811500	38.03	46.00	7.97	100	9	ON	9.9
0.915000	39.54	46.00	6.46	100	9	ON	9.9
1.315500	37.54	46.00	8.46	100	9	ON	9.9
1.419000	36.72	46.00	9.28	100	9	ON	9.9

Sample calculation:

Correction factor (dB) = LISN factor IL (dB) + cable loss (dB) + attenuator (dB)

Result (dB μ V) = XX dB μ V (reading from receiver) + XX dB (Correction factor)

Example:

43.5 dB μ V = 23.2 dB μ V (receiver reading) + 10.1 dB (LISN factor IL) + 0.2 dB (cable loss) + 10 dB (attenuator)

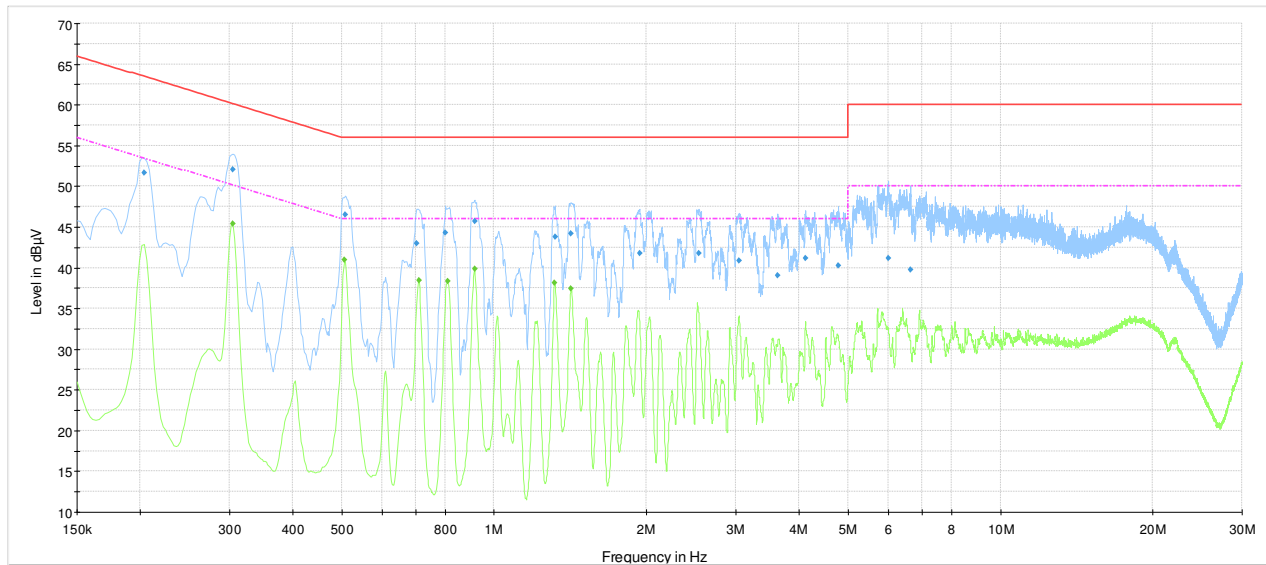

- Conducted emissions on neutral line
- Preview Result 2-AVG
- Preview Result 1-PK+
- CISPR 22 Mains Q-Peak Class B Limit
- CISPR 22 Mains Average Class B Limit
- Final_Result QPK
- Final_Result CAV

Plot 8.9-4: Conducted emissions on neutral line, 48 V_{DC} PS



Table 8.9-8: Quasi-Peak conducted emissions results on neutral line

Frequency, MHz	Q-Peak result, dBµV	Limit, dBµV	Margin, dB	Meas. Time, ms	Bandwidth, kHz	Filter	Correction, dB
0.204000	51.65	63.45	11.80	100	9	ON	9.9
0.305250	52.07	60.10	8.03	100	9	ON	9.8
0.507750	46.47	56.00	9.53	100	9	ON	10.0
0.703500	42.97	56.00	13.03	100	9	ON	9.9
0.802500	44.32	56.00	11.68	100	9	ON	9.9
0.915000	45.66	56.00	10.34	100	9	ON	9.9
1.320000	43.80	56.00	12.20	100	9	ON	9.9
1.416750	44.20	56.00	11.80	100	9	ON	9.9
1.936500	41.75	56.00	14.25	100	9	ON	9.9
2.537250	41.74	56.00	14.26	100	9	ON	9.9
3.043500	40.88	56.00	15.12	100	9	ON	9.9
3.633000	39.03	56.00	16.97	100	9	ON	9.9
4.121250	41.12	56.00	14.88	100	9	ON	9.9
4.778250	40.22	56.00	15.78	100	9	ON	10.0
6.004500	41.20	60.00	18.80	100	9	ON	10.1
6.634500	39.71	60.00	20.29	100	9	ON	10.1

Note: 43.5 dBµV = 23.2 dBµV (receiver reading) + 10.1 dB (LISN factor IL) + 0.2 dB (cable loss) + 10 dB (attenuator)

Table 8.9-9: Average conducted emissions results on neutral line

Frequency, MHz	CAverage result, dBµV	Limit, dBµV	Margin, dB	Meas. Time, ms	Bandwidth, kHz	Filter	Correction, dB
0.305250	45.42	50.10	4.68	100	9	ON	9.8
0.505500	40.92	46.00	5.08	100	9	ON	10.0
0.710250	38.45	46.00	7.55	100	9	ON	9.9
0.811500	38.35	46.00	7.65	100	9	ON	9.9
0.915000	39.82	46.00	6.18	100	9	ON	9.9
1.317750	38.14	46.00	7.86	100	9	ON	9.9
1.419000	37.38	46.00	8.62	100	9	ON	9.9

Sample calculation:

Correction factor (dB) = LISN factor IL (dB) + cable loss (dB) + attenuator (dB)

Result (dBµV) = XX dBµV (reading from receiver) + XX dB (Correction factor)

Example:

43.5 dBµV = 23.2 dBµV (receiver reading) + 10.1 dB (LISN factor IL) + 0.2 dB (cable loss) + 10 dB (attenuator)

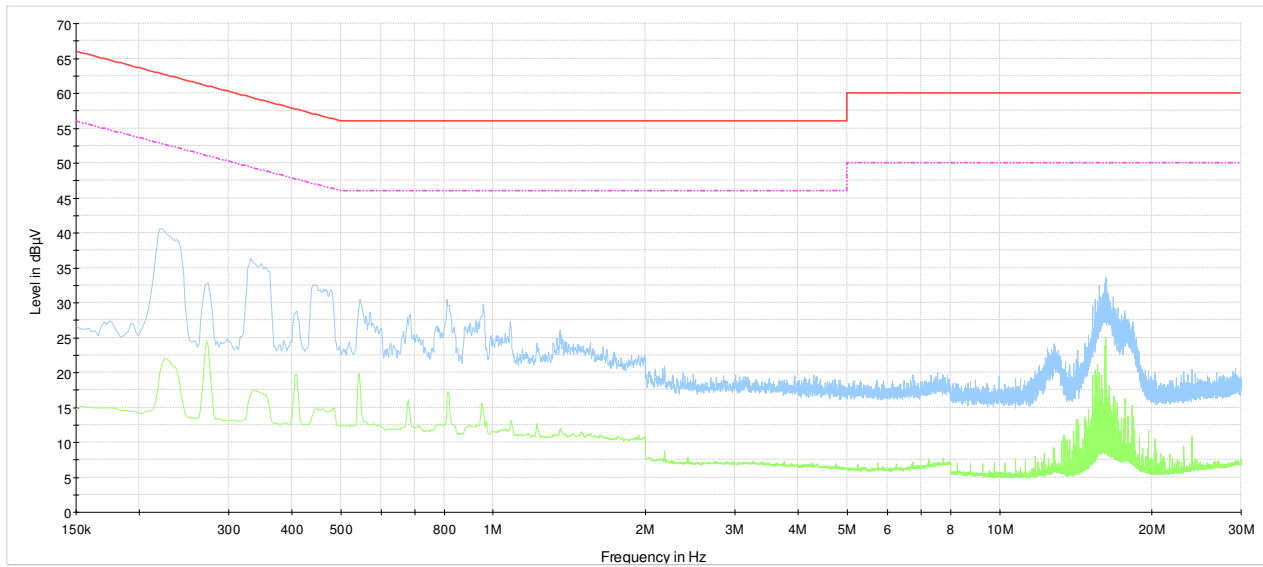

- Conducted emissions on phase line
- Preview Result 2-AVG
- Preview Result 1-PK+
- CISPR 22 Mains O-Peak Class B Limit
- CISPR 22 Mains Average Class B Limit
- Final_Result QPK
- Final_Result CAV

Plot 8.9-5: Conducted emissions on phase line, AC PS

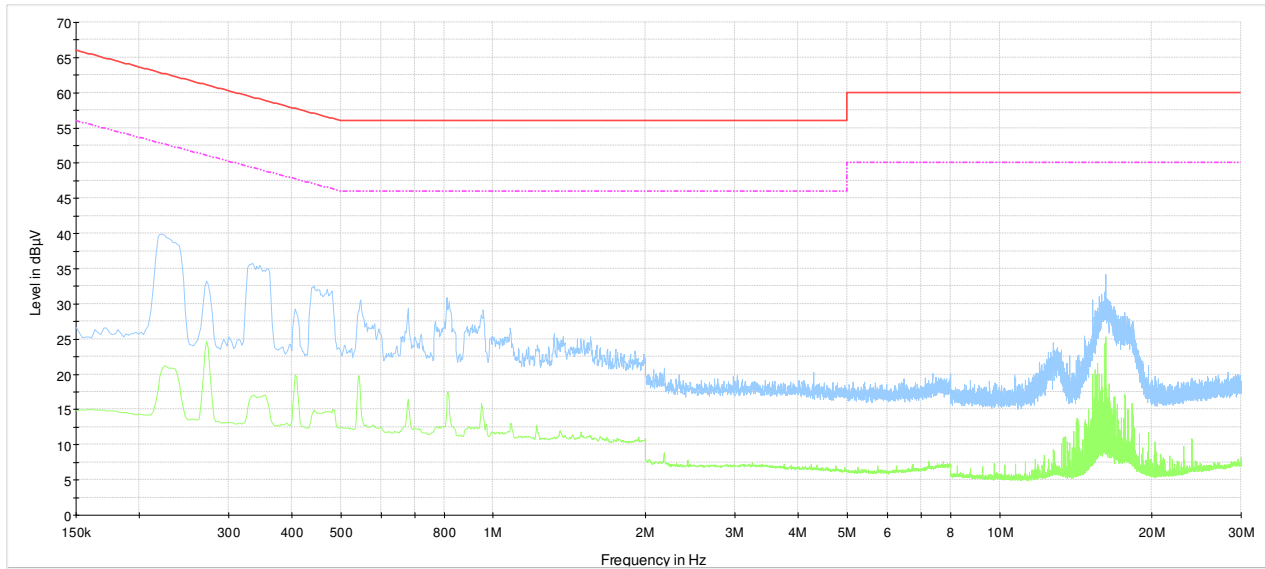

- Conducted emissions on neutral line
- Preview Result 2-AVG
- Preview Result 1-PK+
- CISPR 22 Mains O-Peak Class B Limit
- CISPR 22 Mains Average Class B Limit
- Final_Result QPK
- Final_Result CAV

Plot 8.9-6: Conducted emissions on neutral line, AC PS

8.10 FCC 15.407(g) and RSS-Gen 8.11 Frequency stability

8.10.1 Definitions and limits

Manufacturers of U-NII devices are responsible for ensuring frequency stability such that an emission is maintained within the band of operation under all conditions of normal operation as specified in the user's manual.

8.10.2 Test summary

Test date:	December 5, 2016	Temperature:	23 °C
Test engineer:	Andrey Adelberg	Air pressure:	1008 mbar
Verdict:	Pass	Relative humidity:	34 %

8.10.3 Observations, settings and special notes

Spectrum analyser settings:

Resolution bandwidth:	100 kHz
Video bandwidth:	300 kHz
Detector mode:	Peak
Trace mode:	Max Hold

8.10.4 Test data

Table 8.10-1: Frequency drift measurement for 5150–5250 MHz band

Test conditions	Frequency, GHz	Drift, Hz
+50 °C, Nominal	5.180004656	-35
+40 °C, Nominal	5.180091807	52
+30 °C, Nominal	5.180103741	64
+20 °C, +15 %	5.180107031	67
+20 °C, Nominal	5.180040064	<i>Reference</i>
+20 °C, -15 %	5.180139735	100
+10 °C, Nominal	5.180028461	-12
0 °C, Nominal	5.180134005	94
-10 °C, Nominal	5.180125293	85
-20 °C, Nominal	5.180098284	58
-30 °C, Nominal	5.180056019	16

Table 8.10-2: Frequency drift measurement for 5250–5350 MHz band

Test conditions	Frequency, GHz	Drift, Hz
+50 °C, Nominal	5.299878702	-41
+40 °C, Nominal	5.300006847	87
+30 °C, Nominal	5.300002401	83
+20 °C, +15 %	5.299961722	42
+20 °C, Nominal	5.299919872	Reference
+20 °C, -15 %	5.300012970	93
+10 °C, Nominal	5.299979342	59
0 °C, Nominal	5.299941578	22
-10 °C, Nominal	5.299972536	53
-20 °C, Nominal	5.299902051	-18
-30 °C, Nominal	5.299956431	37

Table 8.10-3: Frequency drift measurement for 5470–5725 MHz band

Test conditions	Frequency, GHz	Drift, Hz
+50 °C, Nominal	5.550155154	91
+40 °C, Nominal	5.550138271	74
+30 °C, Nominal	5.550130595	66
+20 °C, +15 %	5.550078036	14
+20 °C, Nominal	5.550064103	Reference
+20 °C, -15 %	5.550074864	11
+10 °C, Nominal	5.550081643	18
0 °C, Nominal	5.550144667	81
-10 °C, Nominal	5.550056250	-8
-20 °C, Nominal	5.550109154	45
-30 °C, Nominal	5.550098574	34

Table 8.10-4: Frequency drift measurement for 5725–5850 MHz band

Test conditions	Frequency, GHz	Drift, Hz
+50 °C, Nominal	5.785017193	49
+40 °C, Nominal	5.785057439	89
+30 °C, Nominal	5.784987341	19
+20 °C, +15 %	5.785003894	36
+20 °C, Nominal	5.784967949	Reference
+20 °C, -15 %	5.785017369	49
+10 °C, Nominal	5.78501189	44
0 °C, Nominal	5.784978377	10
-10 °C, Nominal	5.784976408	8
-20 °C, Nominal	5.784968057	0
-30 °C, Nominal	5.785012484	45

Section 9. Block diagrams of test set-ups

9.1 Radiated emissions set-up for frequencies below 1 GHz

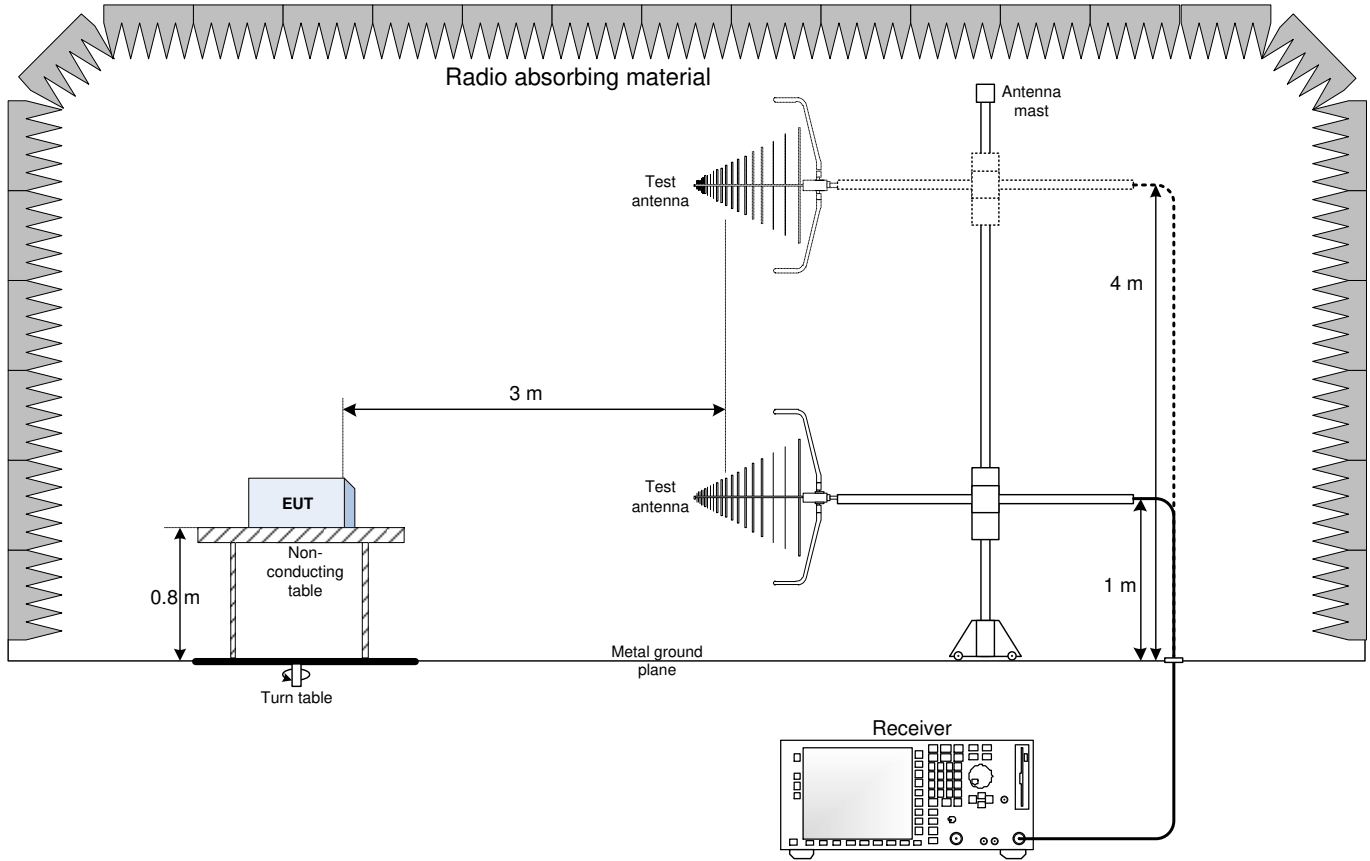

9.2 Radiated emissions set-up for frequencies above 1 GHz

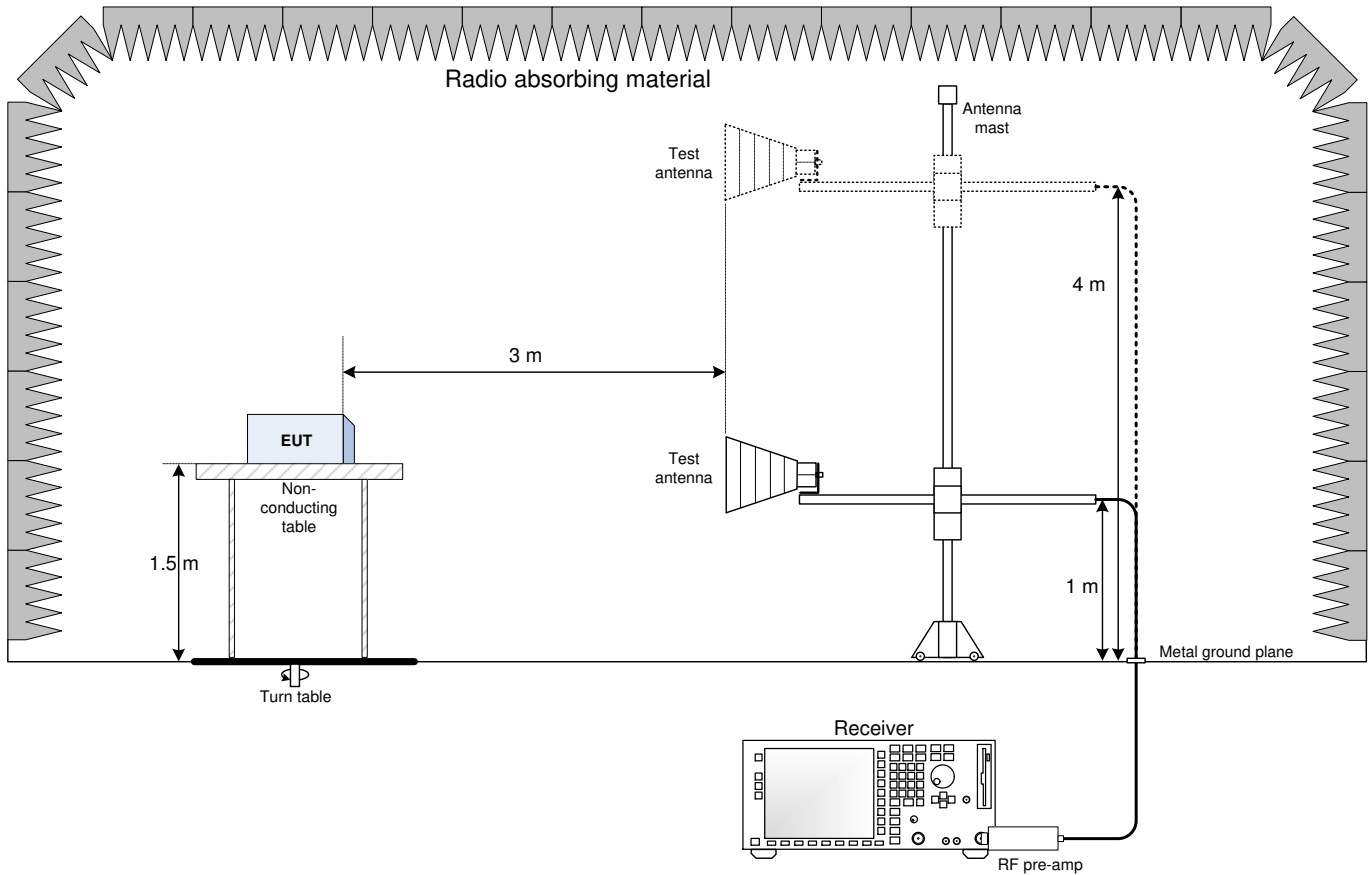

9.3 Conducted emissions set-up

