

FCC Test Report

Part 15 subpart C

Application Type : Class II Permissive Change

Class II Permissive Change : please see FCC change documents

Original Grant Date : 09/10/2014

Client Information:

Applicant : Ascion, LLC
Applicant add.: 341 Central Avenue Silver Creek, NY 14136

EUT Information:

EUT Name : Reverie 4.1 Bluetooth Speaker
Model No. : AM-BT-S01
Brand Name : 
FCC ID : VFK-AM-BT-S01

Prepared By:

Asia Institute Technology (Dongguan) Limited

Add. : No. 22, JinQianLing Street 3, JiTiGang Village HuangJiang Town, DongGuan,
GuangDong, China.

Date of Receipt: Jan. 29, 2015

Date of Test: Jan. 30, 2015~Feb. 02, 2015

Date of Issue: Feb. 02, 2015

Test Result: **Pass**

Test procedure used: ANSI C63.4-2009

This device described above has been tested by Asia Institute Technology (Dongguan) Limited, and the test results show that the equipment under test (EUT) is in compliance with the FCC requirements. And it is applicable only to the tested sample identified in the report.

*This test report must not be used by the client to claim product endorsement by any agency of the U.S. government.

Reviewed by:



Seal.Chen

Approved by:



Jackie.Deng

1 Contents

	Page
COVER PAGE	
1 CONTENTS.....	2
2 TEST SUMMARY.....	3
2.1 COMPLIANCE WITH FCC PART 15 SUBPART C	3
2.2 MEASUREMENT UNCERTAINTY	5
3 TEST FACILITY	6
3.1 DEVIATION FROM STANDARD	6
3.2 ABNORMALITIES FROM STANDARD CONDITIONS	6
4 GENERAL INFORMATION	7
4.1 GENERAL DESCRIPTION OF EUT	7
4.2 DESCRIPTION OF TEST CONDITIONS	9
4.3 EUT PERIPHERAL LIST	10
4.4 TEST PERIPHERAL LIST	10
5 EQUIPMENTS LIST FOR ALL TEST ITEMS.....	11
6 TEST RESULT	12
6.1 CONDUCTION EMISSIONS MEASUREMENT	12
6.1.1 Applied procedures / Limit.....	12
6.1.2 Test procedure	12
6.1.3 Test results	13
6.2 RADIATED EMISSIONS MEASUREMENT	15
6.2.1 Applied procedures / Limit.....	15
6.2.2 Test procedure	15
6.2.3 Test Result	16
6.2.4 TEST RESULTS (Restricted Bands Requirements).....	24
6.3 MAXIMUM PEAK OUTPUT POWER	25
6.3.1 Applied procedures / Limit.....	25
6.3.2 Test procedure	25
6.3.3 Deviation from standard	25
6.3.4 Test setup.....	25
6.3.5 Test results	26

2 Test Summary

2.1 Compliance with FCC Part 15 subpart C

Test	Test Requirement	Standard Paragraph	Result
Conduction Emissions	FCC Part 15 C:2013	Section 15.207(a)	PASS
Radiated Emissions	FCC Part 15 C:2013	Section 15.247(d)	PASS
Maximum Peak Output Power	FCC Part 15 C:2013	Section 15.247(b)	PASS
Band edge	FCC Part 15 C:2013	Section 15.247(d)	PASS

Note:1. Reference to the FCC Public Notice DA 00-705

2.Original circuit as below:

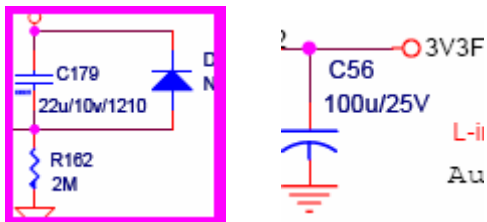

Modified circuit as below:

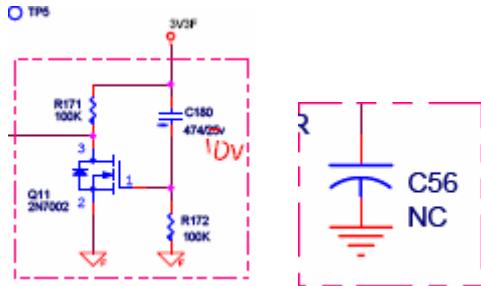

1. Change C56 from 100 μ /25V to NC
2. Change C168 from 1n/10V to 1n/50V
3. Replaced D9 (4148),C179 (22 μ /10v) and R162 (2M) with Q11 (2N7002), R171 (100K), C180 (474/10v) incl. PCB layout change

Except for the changes above, no other modification is performed. There is no hardware or electrical modification made to the applying transmitter itself. These changes enhance module power supply stability, other parameters are the same as the voltage and current, and will not affect the Bluetooth module and the RF characteristic will not change

So, the EUT need to be retested for Radiated Emission, Conducted Emission and Maximum Peak Output Power. The test data of other items is the same with the original report E-F1406001-1.

2.2 Measurement Uncertainty

All measurements involve certain levels of uncertainties, The following measurements uncertainty Levels have estimated based on ANSI C63.4:2009, the maximum value of the uncertainty as below

No.	Item	Uncertainty
1	Conducted Emission Test	1.20dB
2	Radiated Emission Test	3.30dB

3 Test Facility

The test facility is recognized, certified or accredited by the following organizations:

.CNAS- Registration No: L6177

Dongguan Yaxu (AiT) technology Limited is accredited to ISO/IEC 17025:2005 general Requirements for the competence of testing and calibration laboratories (CNAS-CL01 Accreditation Criteria for the competence of testing and calibration laboratories) on Apr. 18, 2013

.FCC- Registration No: 248337

The 3m Semi-Anechoic Chamber, 3m/10m Open Area Test Site and Shielding Room of Asia Institute Technology (Dongguan) Limited have been registered by Federal Communications Commission (FCC) on Dec.19, 2012.

.Industry Canada(IC)-Registration No: IC6819A-1 & IC6819A-2

The 3m Semi-Anechoic Chamber and 3m/10m Open Area Test Site of Asia Institute Technology (Dongguan) Limited have been registered by Certification and Engineering Bureau of Industry Canada for radio equipment testing on Jun. 12, 2013.

.VCCI- Registration No: 2705

The 3m/10m Open Area Test Site, Shielding Room and 3m Chamber of Asia Institute Technology (Dongguan) Limited have been registered by Voluntary Control Council for Interference on Nov. 21, 2012. The Telecommunication Ports Conducted Disturbance Measurement of Asia Institute Technology (Dongguan) Limited have been registered by Voluntary Control Council for Interference on Sep. 06, 2011.

.TUV NORD

Asia Institute Technology (Dongguan) Limited has been assessed on Jun. 13, 2013 that it can carry out EMC tests by order and under supervision of TUV NORD.

.ITS- Registration No: TMPSHA031

Asia Institute Technology (Dongguan) Limited has been assessed and included in Intertek Shanghai TMP Program regarding Laboratory facilities and test equipment on Jul.22, 2012.

3.1 Deviation from standard

None

3.2 Abnormalities from standard conditions

None

4 General Information

4.1 General Description of EUT

Manufacturer:	GIGATEK ELECTRONICS (DongGuan) CO.,LTD		
Manufacturer Address:	IN Yang Industrial, Zhangyang District, Zhangmutou Town, Dongguan City, Guandong, China 523636		
EUT Name:	Reverie 4.1 Bluetooth Speaker		
Model No:	AM-BT-S01		
Operation frequency:	2402 MHz to 2480 MHz		
NUMBER OF CHANNEL:	79		
Modulation Technology:	GFSK, Π/4-DQPSK, 8DPSK(1/2/3Mbps)		
Antenna Type:	dipole		
Antenna Gain:	max 2.11dBi		
Brand Name:			
Serial No:	N/A		
Power Supply Range:	Input: 100-240Vac, 50/60Hz, 1.5A Output: DC 16V 3.2A		
Power Supply:	DC 16.0V from Adapter, AC 120V/60Hz for Adapter		
Power Cord:	N/A		
Output power (max) :	The old data	1Mbps: 6.60dBm	
		3Mbps: 5.05dBm	
	The new data	1Mbps: 6.50dBm	
		3Mbps: 5.03dBm	
Note:			
	1.	For a more detailed features description, please refer to the manufacturer's specifications or the User's Manual.	

Description of Channel:					
Channel	Frequency (MHz)	Channel	Frequency (MHz)	Channel	Frequency (MHz)
00	2402	27	2429	54	2456
01	2403	28	2430	55	2457
02	2404	29	2431	56	2458
03	2405	30	2432	57	2459
04	2406	31	2433	58	2460
05	2407	32	2434	59	2461
06	2408	33	2435	60	2462
07	2409	34	2436	61	2463
08	2410	35	2437	62	2464
09	2411	36	2438	63	2465
10	2412	37	2439	64	2466
11	2413	38	2440	65	2467
12	2414	39	2441	66	2468
13	2415	40	2442	67	2469
14	2416	41	2443	68	2470
15	2417	42	2444	69	2471
16	2418	43	2445	70	2472
17	2419	44	2446	71	2473
18	2420	45	2447	72	2474
19	2421	46	2448	73	2475
20	2422	47	2449	74	2476
21	2423	48	2450	75	2477
22	2424	49	2451	76	2478
23	2425	50	2452	77	2479
24	2426	51	2453	78	2480
25	2427	52	2454		
26	2428	53	2455		

4.2 Description of Test conditions

(1) EUT was tested in normal configuration (Please See following Block diagram)

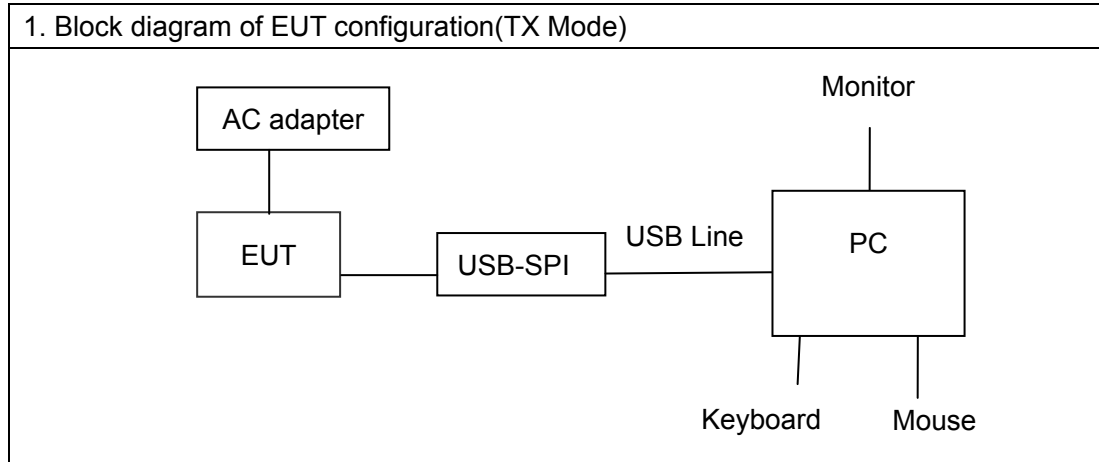

(2) E.U.T. test conditions:

15.31(e): For intentional radiators, measurements of the variation of the input power or the adiated signal level of the fundamental frequency component of the emission, as appropriate, shall be performed with the supply voltage varied between 85% and 115% of the nominal rated supply voltage. For battery operated equipment, the equipment tests shall be performed using a new battery.

(3) Test frequencies:

According to the 15.31(m) Measurements on intentional radiators or receivers, other than TV broadcast receivers, shall be performed and. If required reported for each band in which the device can be operated with the device operating at the number of frequencies in each band specified in the following table:

Frequency range over which device operates	Number of frequencies	Location in the range of operation
1 MHz or less	1	Middle
1 to 10 MHz	2	1 near top and 1 near bottom
More than 10 MHz	3	1 near top, 1 near middle and 1 near bottom

(4) Frequency range of radiated measurements:

According to the 15.33, the test range will be up to the tenth harmonic of the highest fundamental frequency.

4.3 EUT Peripheral List

No.	Equipment	Manufacturer	Model No.	Serial No.	Power cord	signal cable
1	N/A	N/A	N/A	N/A	N/A	N/A

4.4 Test Peripheral List

No.	Equipment	Manufacturer	EMC Compliance	Model No.	Serial No.	Power cord	signal cable
1	Personal computer	H P	CE 、 FCC	DX2310	CNG8250MZ3	1.8m/unshielded /detachable	N/A
2	Keyboard	DELL	CE	SK-8115	CN-ONM432-71616-81M-OLK B	N/A	1.5m/unshielded /undetachable
3	Mouse	Microsoft	CE	X800898	30603	N/A	1.5m/unshielded /undetachable
4	Monitor	DELL	CE	T980KAC DK21SN	TWS20006045	1.8m/unshielded /detachable	1.8m/shielded /detachable
5	USB-SPI	CSR	N/A	N/A	N/A	N/A	0.8m/shielded /detachable

5 Equipments List for All Test Items

No	Test Equipment	Manufacturer	Model No	Serial No	Cal. Date	Cal. Due Date
1	Spectrum Analyzer	ADVANTEST	R3182	150900201	2014.06.27	2015.06.26
2	EMI Measuring Receiver	R&S	ESR	101160	2014.04.22	2015.04.21
3	Low Noise Pre Amplifier	Tsj	MLA-10K01-B01-27	1205323	2014.06.27	2015.06.26
4	Low Noise Pre Amplifier	Tsj	MLA-0120-A02-34	2648A04738	2014.12.02	2015.12.01
5	TRILOG Super Broadband test Antenna	SCHWARZBEC K	VULB9160	9160-3206	2014.12.03	2015.12.02
6	Broadband Horn Antenna	SCHWARZBEC K	BBHA9120D	452	2014.12.03	2015.12.02
7	SHF-EHF Horn	SCHWARZBEC K	BBHA9170	BBHA9170367	2014.12.03	2015.12.02
8	50Ω Coaxial Switch	Anritsu	MP59B	6200264416	2014.09.26	2015.09.25
9	EMI Test Receiver	R&S	ESCI	100124	2014.06.20	2015.06.19
10	LISN	Kyoritsu	KNW-242	8-837-4	2014.06.20	2015.06.19
11	LISN	Kyoritsu	KNW-407	8-1789-3	2014.06.20	2015.06.19
12	50Ω Coaxial Switch	Anritsu	MP59B	6200264417	2014.09.25	2015.09.24
13	Loop Antenna	ARA	PLA-1030/B	1029	2014.03.19	2015.03.18
14	Power Meter	R&S	NRVS	101336	2014.06.27	2015.06.26
15	Power Sensor	R&S	URV5-Z7	100077	2014.06.27	2015.06.26
16	Radiated Cable 1# (30MHz-1GHz)	FUJIKURA	5D-2W	01	2015.01.04	2016.01.03
17	Radiated Cable 2# (1GHz -25GHz)	FUJIKURA	10D2W	02	2014.12.25	2015.12.24
18	Conducted Cable 1#(9KHz-30MHz)	FUJIKURA	1D-2W	01	2015.01.04	2016.01.03

6 Test Result

6.1 Conduction Emissions Measurement

6.1.1 Applied procedures / Limit

Frequency of Emission (MHz)	Conducted Limit (dB μ V)	
	Quasi-peak	Average
0.15-0.5	66 to 56 *	56 to 46 *
0.5-5	56	46
5-30	60	50

Note: Decreases with the logarithm of the frequency.

6.1.2 Test procedure

EUT was placed upon a wooden test table 0.8m above the horizontal metal reference plane and 0.4m from the vertical ground plane, and it was connected to an AMN. The closest distance between the boundary of the EUT and the surface of the AMN is 0.8m. All peripherals were connected to another AMN, and placed at a distance of 10cm from each other. A spectrum and receiver was connected to the RF output port of the AMN. Both average and quasi-peak value were detected.

6.1.3 Test results

EUT:	Reverie 4.1 Bluetooth Speaker	Model Name. :	AM-BT-S01
Temperature:	26 °C	Relative Humidity:	54%
Pressure:	1010hPa	Test Date :	2015-01-30
Test Mode:	TX	Phase :	Line
Test Voltage :	DC 16.0V from Adapter,AC 120V/60Hz for Adapter		

Frequency (MHz)	Meter Reading (dBμV)	Factor(dB)	Emission Level (dBμV)	Limits (dBμV)	Margin (dB)	Detector
*0.1620	57.74	2.64	60.38	65.36	-4.98	Quasi-Peak
0.1620	40.56	2.64	43.20	55.36	-12.16	Average
0.2467	42.97	1.87	44.84	61.86	-17.02	Quasi-Peak
0.2467	26.20	1.87	28.07	51.86	-23.79	Average
0.5140	32.59	10.01	42.60	56.00	-13.40	Quasi-Peak
0.5140	24.54	10.01	34.55	46.00	-11.45	Average

Remark:

1. Factor = Insertion Loss + Cable Loss.

2. '*' means the worst case.

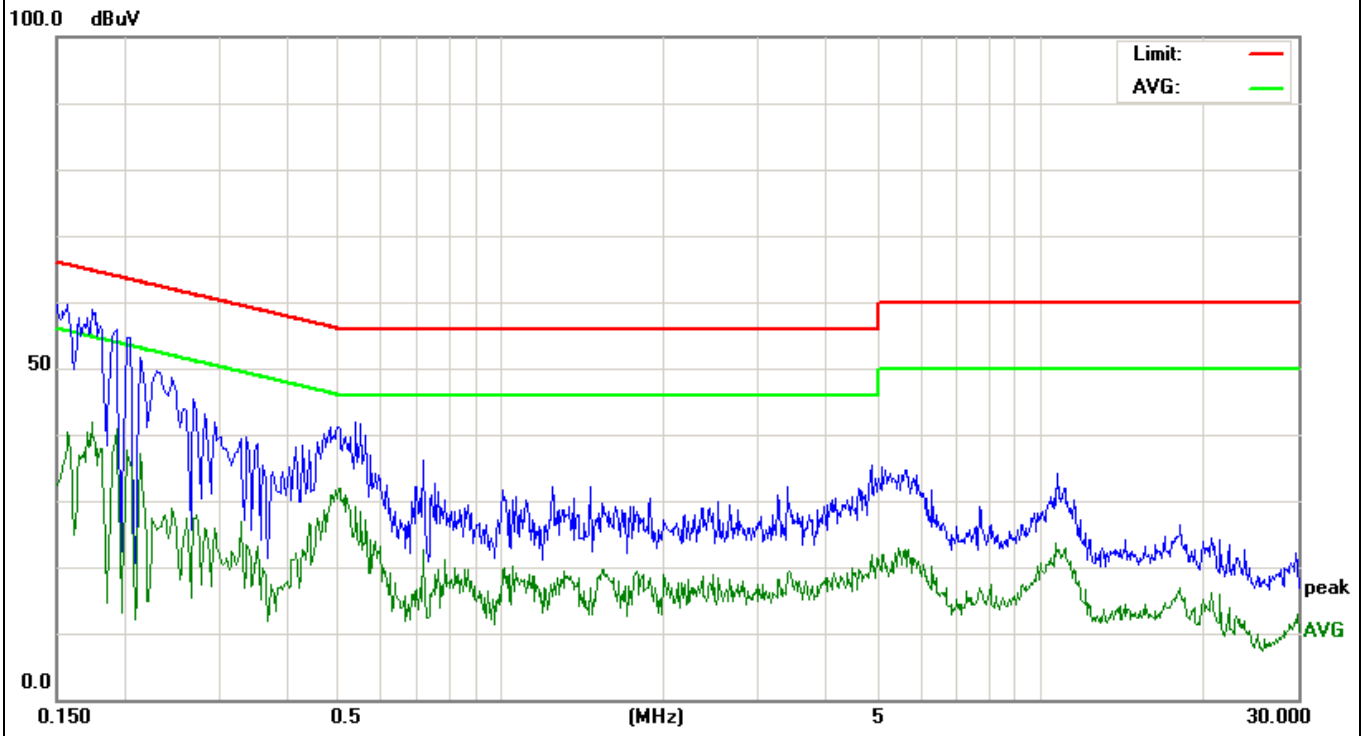

EUT:	Reverie 4.1 Bluetooth Speaker	Model Name. :	AM-BT-S01
Temperature:	26 °C	Relative Humidity:	54%
Pressure:	1010hPa	Test Date :	2015-01-30
Test Mode:	TX	Phase :	Neutral
Test Voltage :	DC 16.0V from Adapter,AC 120V/60Hz for Adapter		

Frequency (MHz)	Meter Reading (dBμV)	Factor(dB)	Emission Level (dBμV)	Limits (dBμV)	Margin (dB)	Detector
*0.1819	55.66	2.32	57.98	64.39	-6.41	Quasi-Peak
0.1819	40.55	2.32	42.87	54.39	-11.52	Average
0.5180	35.09	10.01	45.10	56.00	-10.90	Quasi-Peak
0.5180	25.53	10.01	35.54	46.00	-10.46	Average
1.3740	20.48	9.96	30.44	56.00	-25.56	Quasi-Peak
1.3740	12.39	9.96	22.35	46.00	-23.65	Average

Remark:

- Factor = Insertion Loss + Cable Loss.
- '*' means the worst case.

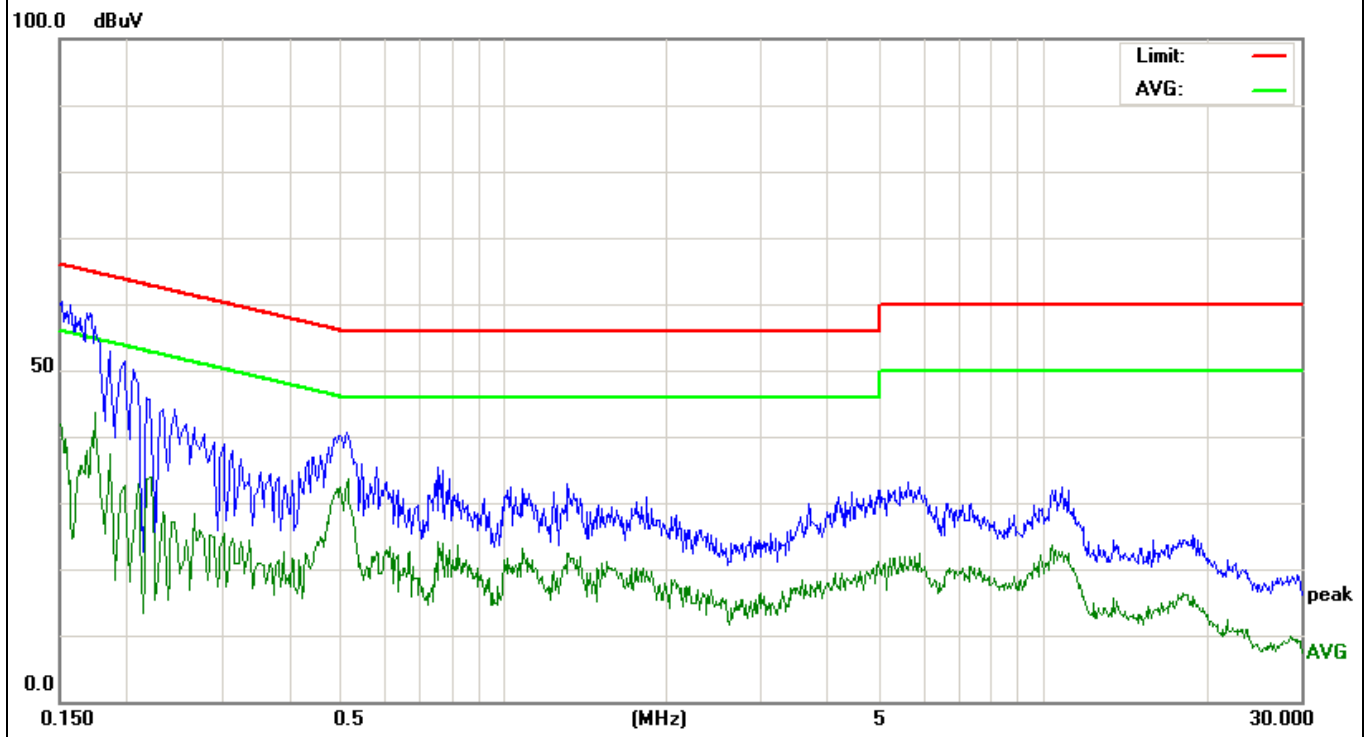

6.2 Radiated Emissions Measurement

6.2.1 Applied procedures / Limit

15.247(d) In any 100 kHz bandwidth outside the frequency band in which the spread spectrum or digitally modulated intentional radiator is operating, the radio frequency power that is produced by the intentional radiator shall be at least 20 dB below that in the 100 kHz bandwidth within the band that contains the highest level of the desired power, based on either an RF conducted or a radiated measurement, provided the transmitter demonstrates compliance with the peak conducted power limits. If the transmitter complies with the conducted power limits based on the use of RMS averaging over a time interval, as permitted under paragraph (b)(3) of this section, the attenuation required under this paragraph shall be 30 dB instead of 20 dB. Attenuation below the general limits specified in Section 15.209(a) is not required. In addition, radiated emissions which fall in the restricted bands, as defined in Section 15.205(a), must also comply with the radiated emission limits specified in Section 15.209(a) (see Section 15.205(c)).

Frequency of Emission (MHz)	Field Strength		Measurement Distance (meters)
	$\mu\text{V/m}$	$\text{dB}\mu\text{V/m}$	
0.009-0.49	2400/F(kHz)		300
0.49-1.705	24000/F(kHz)		30
1.705-30	30		30
30-88	100	40	3
88-216	150	43.5	3
216-960	200	46	3
Above 960	500	54	3

6.2.2 Test procedure

EUT was placed upon a wooden test table which was placed on the turn table 0.8m above the horizontal metal ground plane, and operating in the mode as mentioned above. A receiving antenna was placed 3m away from the EUT. During testing, turn around the turn table and move the antenna from 1m to 4m to find the maximum field-strength reading. All peripherals were placed at a distance of 10cm between each other. Both horizontal and vertical antenna polarities were tested and performed pretest to three orthogonal axis. The worst case emissions were reported.

6.2.3 Test Result

Radiated Emissions Test Data Below 30MHz

EUT:	Reverie 4.1 Bluetooth Speaker	Model Name :	AM-BT-S01
Temperature:	25 °C	Test Data	2015-01-30
Pressure:	1005 hPa	Relative Humidity:	60%
Test Mode :	TX	Test Voltage :	DC 16.0 V from Adapter AC 120V/60Hz for Adapter
Measurement Distance	3 m	Frenqucy Range	9KHz to 30MHz
RBW/VBW	9KHz~150KHz/RB 200Hz for QP, 150KHz~30MHz/RB 9KHz for QP		

No emission found between lowest internal used/generated frequencies to 30MHz.

Radiated Emissions Test Data Below 1GHz

EUT:	Reverie 4.1 Bluetooth Speaker	Model Name :	AM-BT-S01
Temperature:	25 °C	Test Data	2015-01-30
Pressure:	1010 hPa	Relative Humidity:	60%
Test Mode :	TX	Test Voltage :	DC 16.0 V from Adapter AC 120V/60Hz for Adapter
Measurement Distance	3 m	Frenqucy Range	30MHz to 1GHz
RBW/VBW	100KHz / 300KHz for spectrum, RBW=120KHz for receiver.		

(a) Antenna polarization: Horizontal

Frequency (MHz)	Reading Level (dBuV)	Correct Factor (dB)	Measure Level (dBuV/m)	Limit (dBuV/m)	Margin (dB)	Detector Type
*58.6126	52.32	-17.02	35.30	40.00	-4.70	QUASIPeAK
64.2074	50.14	-17.84	32.30	40.00	-7.70	QUASIPeAK
80.3619	47.45	-18.15	29.30	40.00	-10.70	QUASIPeAK
191.7450	43.31	-14.62	28.69	43.50	-14.81	QUASIPeAK
222.9501	44.35	-13.75	30.60	46.00	-15.40	QUASIPeAK
333.6865	41.46	-8.86	32.60	46.00	-13.40	QUASIPeAK

(b) Antenna polarization: vertical

Frequency (MHz)	Reading Level (dBuV)	Correct Factor (dB)	Measure Level (dBuV/m)	Limit (dBuV/m)	Margin (dB)	Detector Type
59.6492	46.87	-17.84	29.03	40.00	-10.97	QUASIPeAK
*79.8002	52.61	-20.21	32.40	40.00	-7.60	QUASIPeAK
159.7844	45.33	-17.01	28.32	43.50	-15.18	QUASIPeAK
175.6516	45.78	-15.51	30.27	43.50	-13.23	QUASIPeAK
228.4903	42.22	-13.12	29.10	46.00	-16.90	QUASIPeAK
349.2500	33.14	-8.34	24.80	46.00	-21.20	QUASIPeAK

Note: '*' means the worst case

Measurement Level = Reading Level + Factor

Factor=Ant Factor + Cable Loss – Pre-amplifier.

Radiated Emissions Test Data Above 1GHz

EUT:	Reverie 4.1 Bluetooth Speaker	Model Name :	AM-BT-S01
Temperature:	25 °C	Test Data	2015-01-30
Pressure:	1010 hPa	Relative Humidity:	60%
Test Mode :	1Mbps	Test Voltage :	DC 16.0 V from Adapter AC 120V/60Hz for Adapter
Measurement Distance	3 m	Frenqucy Range	1GHz to 25GHz
RBW/VBW	1MHz/1MHz for Peak, 1MHz/10Hz for Average.		

(a) Antenna polarization: Horizontal

Frequency (MHz)	Reading Level (dBuV)	Correct Factor (dB)	Measure Level (dBuV/m)	Limit (dBuV/m)	Margin (dB)	Detector Type
2400.000	46.35	-5.70	40.65	74.00	-33.35	PEAK
2400.000	36.01	-5.70	30.31	54.00	-23.69	AVERAGE
4804.000	57.22	5.06	62.28	74.00	-11.72	PEAK
*4804.000	40.37	5.06	45.43	54.00	-8.57	AVERAGE
7206.000	44.16	7.03	51.19	74.00	-22.81	PEAK
7206.000	28.96	7.03	35.99	54.00	-18.01	AVERAGE

(b) Antenna polarization: Vertical

Frequency (MHz)	Reading Level (dBuV)	Correct Factor (dB)	Measure Level (dBuV/m)	Limit (dBuV/m)	Margin (dB)	Detector Type
2400.000	47.32	-5.70	41.62	74.00	-32.38	PEAK
2400.000	34.09	-5.70	28.39	54.00	-25.61	AVERAGE
4804.000	57.01	5.06	62.07	74.00	-11.93	PEAK
*4804.000	41.46	5.06	46.52	54.00	-7.48	AVERAGE
7206.000	38.16	7.03	45.19	74.00	-28.81	PEAK
7206.000	26.28	7.03	33.31	54.00	-20.69	AVERAGE

Note: '*' means the worst case

8~25GHz at least have 20dB margin. No recording in the test report.

Measurement Level = Reading Level + Factor

Factor=Ant Factor + Cable Loss – Pre-amplifier.

Low Channel 00: 2402 MHz

Data rate: 1Mbps

(a) Antenna polarization: Horizontal

Frequency (MHz)	Reading Level (dBuV)	Correct Factor (dB)	Measure Level (dBuV/m)	Limit (dBuV/m)	Margin (dB)	Detector Type
4882.000	57.46	5.14	62.60	74.00	-11.40	PEAK
*4882.000	40.21	5.14	45.35	54.00	-8.65	AVERAGE
7323.000	40.00	7.54	47.54	74.00	-26.46	PEAK
7323.000	28.42	7.54	35.96	54.00	-18.04	AVERAGE

(b) Antenna polarization: Vertical

Frequency (MHz)	Reading Level (dBuV)	Correct Factor (dB)	Measure Level (dBuV/m)	Limit (dBuV/m)	Margin (dB)	Detector Type
4882.000	52.44	5.14	57.58	74.00	-16.42	PEAK
*4882.000	37.98	5.14	43.12	54.00	-10.88	AVERAGE
7323.000	39.41	7.54	46.95	74.00	-27.05	PEAK
7323.000	25.51	7.54	33.05	54.00	-20.95	AVERAGE

Note: '*' means the worst case

8~25GHz at least have 20dB margin. No recording in the test report.

Measurement Level = Reading Level + Factor

Factor=Ant Factor + Cable Loss – Pre-amplifier.

Middle Channel 39: 2441 MHz

Data rate: 1Mbps

(a) Antenna polarization: Horizontal

Frequency (MHz)	Reading Level (dBuV)	Correct Factor (dB)	Measure Level (dBuV/m)	Limit (dBuV/m)	Margin (dB)	Detector Type
2483.500	46.38	-4.98	41.40	74.00	-32.60	PEAK
2483.500	31.96	-4.98	26.98	54.00	-27.02	AVERAGE
4960.000	52.88	5.22	58.10	74.00	-15.90	PEAK
*4960.000	35.66	5.22	40.88	54.00	-13.12	AVERAGE
7440.000	37.64	8.06	45.70	74.00	-28.30	PEAK
7440.000	25.23	8.06	33.29	54.00	-20.71	AVERAGE

(b) Antenna polarization: Vertical

Frequency (MHz)	Reading Level (dBuV)	Correct Factor (dB)	Measure Level (dBuV/m)	Limit (dBuV/m)	Margin (dB)	Detector Type
2483.500	47.86	-4.98	42.88	74.00	-31.12	PEAK
2483.500	34.04	-4.98	29.06	54.00	-24.94	AVERAGE
4960.000	51.21	5.22	56.43	74.00	-17.57	PEAK
*4960.000	38.18	5.22	43.40	54.00	-10.60	AVERAGE
7440.000	39.21	8.06	47.27	74.00	-26.73	PEAK
7440.000	25.04	8.06	33.10	54.00	-20.90	AVERAGE

Note: '*' means the worst case

8~25GHz at least have 20dB margin. No recording in the test report.

Measurement Level = Reading Level + Factor

Factor=Ant Factor + Cable Loss – Pre-amplifier.

High Channel 78: 2480 MHz

Data rate: 1Mbps

EUT:	Reverie 4.1 Bluetooth Speaker	Model Name :	AM-BT-S01
Temperature:	25 °C	Test Data	2015-01-30
Pressure:	1010 hPa	Relative Humidity:	60%
Test Mode :	3Mbps	Test Voltage :	DC 16.0 V from Adapter AC 120V/60Hz for Adapter
Measurement Distance	3 m	Frenqucy Range	1GHz to 25GHz
RBW/VBW	1MHz/1MHz for Peak, 1MHz/10Hz for Average.		

(a) Antenna polarization: Horizontal

Frequency (MHz)	Reading Level (dBuV)	Correct Factor (dB)	Measure Level (dBuV/m)	Limit (dBuV/m)	Margin (dB)	Detector Type
2400.000	48.35	-5.70	42.65	74.00	-31.35	PEAK
2400.000	36.11	-5.70	30.41	54.00	-23.59	AVERAGE
4804.000	57.99	5.06	63.05	74.00	-10.95	PEAK
*4804.000	41.25	5.06	46.31	54.00	-7.69	AVERAGE
7206.000	45.12	7.03	52.15	74.00	-21.85	PEAK
7206.000	34.09	7.03	41.12	54.00	-12.88	AVERAGE

(b) Antenna polarization: Vertical

Frequency (MHz)	Reading Level (dBuV)	Correct Factor (dB)	Measure Level (dBuV/m)	Limit (dBuV/m)	Margin (dB)	Detector Type
2400.000	46.25	-5.70	40.55	74.00	-33.45	PEAK
2400.000	35.27	-5.70	29.57	54.00	-24.43	AVERAGE
4804.000	55.14	5.06	60.20	74.00	-13.80	PEAK
*4804.000	41.27	5.06	46.33	54.00	-7.67	AVERAGE
7206.000	39.13	7.03	46.16	74.00	-27.84	PEAK
7206.000	27.19	7.03	34.22	54.00	-19.78	AVERAGE

Note: '**' means the worst case

8~25GHz at least have 20dB margin. No recording in the test report.

Measurement Level = Reading Level + Factor

Factor=Ant Factor + Cable Loss – Pre-amplifier.

Low Channel 00: 2402 MHz

Data rate: 3Mbps

(a) Antenna polarization: Horizontal

Frequency (MHz)	Reading Level (dBuV)	Correct Factor (dB)	Measure Level (dBuV/m)	Limit (dBuV/m)	Margin (dB)	Detector Type
4882.000	58.31	5.14	63.45	74.00	-10.55	PEAK
4882.000	39.11	5.14	44.25	54.00	-9.75	AVERAGE
7323.000	41.25	7.54	48.79	74.00	-25.21	PEAK
7323.000	29.05	7.54	36.59	54.00	-17.41	AVERAGE

(b) Antenna polarization: Vertical

Frequency (MHz)	Reading Level (dBuV)	Correct Factor (dB)	Measure Level (dBuV/m)	Limit (dBuV/m)	Margin (dB)	Detector Type
4882.000	54.33	5.14	59.47	74.00	-14.53	PEAK
*4882.000	38.79	5.14	43.93	54.00	-10.07	AVERAGE
7323.000	40.89	7.54	48.43	74.00	-25.57	PEAK
7323.000	26.13	7.54	33.67	54.00	-20.33	AVERAGE

Note: '*' means the worst case

8~25GHz at least have 20dB margin. No recording in the test report.

Measurement Level = Reading Level + Factor

Factor=Ant Factor + Cable Loss – Pre-amplifier.

Middle Channel 39: 2441 MHz

Data rate: 3Mbps

(a) Antenna polarization: Horizontal

Frequency (MHz)	Reading Level (dBUV)	Correct Factor (dB)	Measure Level (dBUV/m)	Limit (dBUV/m)	Margin (dB)	Detector Type
2483.500	44.64	-4.98	39.66	74.00	-34.34	PEAK
2483.500	32.25	-4.98	27.27	54.00	-26.73	AVERAGE
4960.000	51.31	5.22	56.53	74.00	-17.47	PEAK
4960.000	36.40	5.22	41.62	54.00	-12.38	AVERAGE
7440.000	36.28	8.06	44.34	74.00	-29.66	PEAK
7440.000	21.55	8.06	29.61	54.00	-24.39	AVERAGE

(b) Antenna polarization: Vertical

Frequency (MHz)	Reading Level (dBUV)	Correct Factor (dB)	Measure Level (dBUV/m)	Limit (dBUV/m)	Margin (dB)	Detector Type
2483.500	47.36	-4.98	42.38	74.00	-31.62	PEAK
2483.500	33.88	-4.98	28.90	54.00	-25.10	AVERAGE
4960.000	49.17	5.22	54.39	74.00	-19.61	PEAK
4960.000	37.22	5.22	42.44	54.00	-11.56	AVERAGE
7440.000	37.04	8.06	45.10	74.00	-28.90	PEAK
7440.000	24.38	8.06	32.44	54.00	-21.56	AVERAGE

Note: '*' means the worst case

8~25GHz at least have 20dB margin. No recording in the test report.

Measurement Level = Reading Level + Factor

Factor=Ant Factor + Cable Loss – Pre-amplifier.

High Channel 78: 2480 MHz

Data rate: 3Mbps

6.2.4 TEST RESULTS (Restricted Bands Requirements)

EUT:	Reverie 4.1 Bluetooth Speaker	Model Name :	AM-BT-S01
Temperature:	25 °C	Test Data	2015-01-30
Pressure:	1010 hPa	Relative Humidity:	60%
Test Mode :	TX 1Mbps\ 3Mbps	Test Voltage :	DC 16.0 V from Adapter AC 120V/60Hz for Adapter
Note:	<p>1. The transmitter was setup to transmit at the lowest channel. Then the field strength was measured at 2310-2390 MHz.</p> <p>2. The transmitter was setup to transmit at the highest channel. Then the field strength was measured at 2483.5-2500 MHz.</p>		

Test Mode	Ant.Pol. H/V	Freq. (MHz)	Reading		Ant/CF CF(dB)	Act		Limit	
			Peak (dBuv)	AV (dBuv)		Peak (dBuv/m)	AV (dBuv/m)	Peak (dBuv/m)	AV (dBuv/m)
Data rate 1Mbps	V	2390.00	47.08	34.15	-5.79	41.29	28.36	74.00	54.00
	H	2390.00	46.22	36.29	-5.79	40.43	30.50	74.00	54.00
	V	2483.50	47.86	34.04	-4.98	42.88	29.06	74.00	54.00
	H	2483.50	46.38	31.96	-4.98	41.40	26.98	74.00	54.00
Data rate 3Mbps	V	2390.00	46.14	35.43	-5.79	40.35	29.64	74.00	54.00
	H	2390.00	48.05	36.21	-5.79	42.26	30.42	74.00	54.00
	V	2483.50	47.36	33.88	-4.98	42.38	28.90	74.00	54.00
	H	2483.50	44.64	32.25	-4.98	39.66	27.27	74.00	54.00

Remark:

- (1) Radiated emissions measured in frequency range above 1000MHz were made with an instrument using Peak detector mode.
- (2) During the measurements above 1 GHz it is taken care of that the EUT is always within the 3 dB cone of radiation BW of the used antenna
- (3) Corr.Factor = Antenna Factor + Cable Loss – Pre-amplifier.

6.3 Maximum Peak Output Power

6.3.1 Applied procedures / Limit

15.247(b) (1) For frequency hopping systems operating in the 2400-2483.5 MHz band employing at least 75 non-overlapping hopping channels, and all frequency hopping systems in the 5725-5850 MHz band: 1watt. For all other frequency hopping systems in the 2400-2483.5 MHz band: 0.125 watts.

6.3.2 Test procedure

- (1) Connected the antenna port to the Spectrum Analyzer, set the Spectrum Analyzer as
 Span = approximately 5 times the 20 dB bandwidth, centered on a hopping channel
 RBW > the 20 dB bandwidth of the emission being measured, VBW \geq RBW, Sweep = auto
 Detector function = peak, Trace = max hold
- (2) The EUT should be transmitting at its maximum data rate. Allow the trace to stabilize. Use the marker-to-peak function to set the marker to the peak of the emission. The indicated level is the peak output power.
- (3) The above procedure shall be repeated at the lowest, the middle, and the highest frequency of the stated frequency range with modulated mode. Also shall be performed at different modes of operation.

6.3.3 Deviation from standard

No deviation.

6.3.4 Test setup



6.3.5 Test results

The old data:

EUT:	Reverie 4.1 Bluetooth Speaker	Model Name :	AM-BT-S01
Temperature:	26 °C	Relative Humidity:	60%
Pressure:	1010 hPa	Test Voltage :	DC 16.0 V from Adapter AC 120V/60Hz for Adapter
Test Mode :	TX		
Note: All the data rates have be tested and the worst-case as the table below.			

Test Mode	Frequency	Reading Power (dBm)	Cable Loss (dB)	Peak Output Power (dBm)	Limit (dBm)	Result
Data rate 1Mbps	2402 MHz	4.41	0.5	4.91	30	Pass
	2441 MHz	6.10	0.5	6.60	30	Pass
	2480 MHz	5.76	0.5	6.26	30	Pass
Data rate 3Mbps	2402 MHz	2.70	0.5	3.20	30	Pass
	2441 MHz	4.55	0.5	5.05	30	Pass
	2480 MHz	4.25	0.5	4.75	30	Pass

CH 00-1Mbps

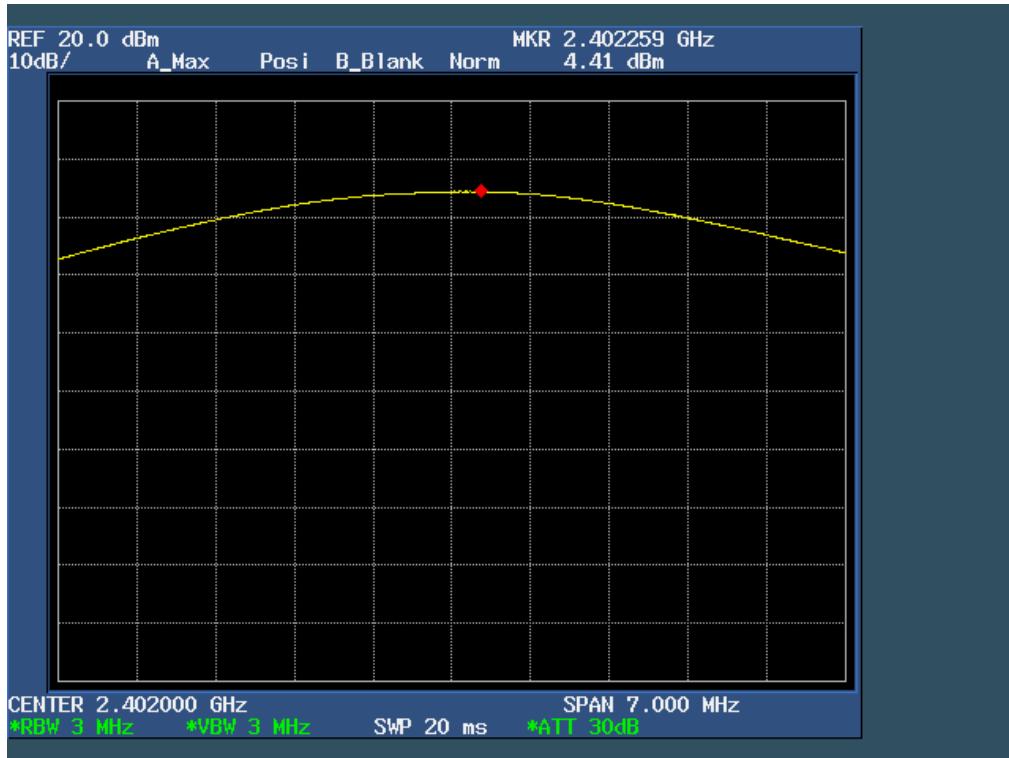

CH 39-1Mbps

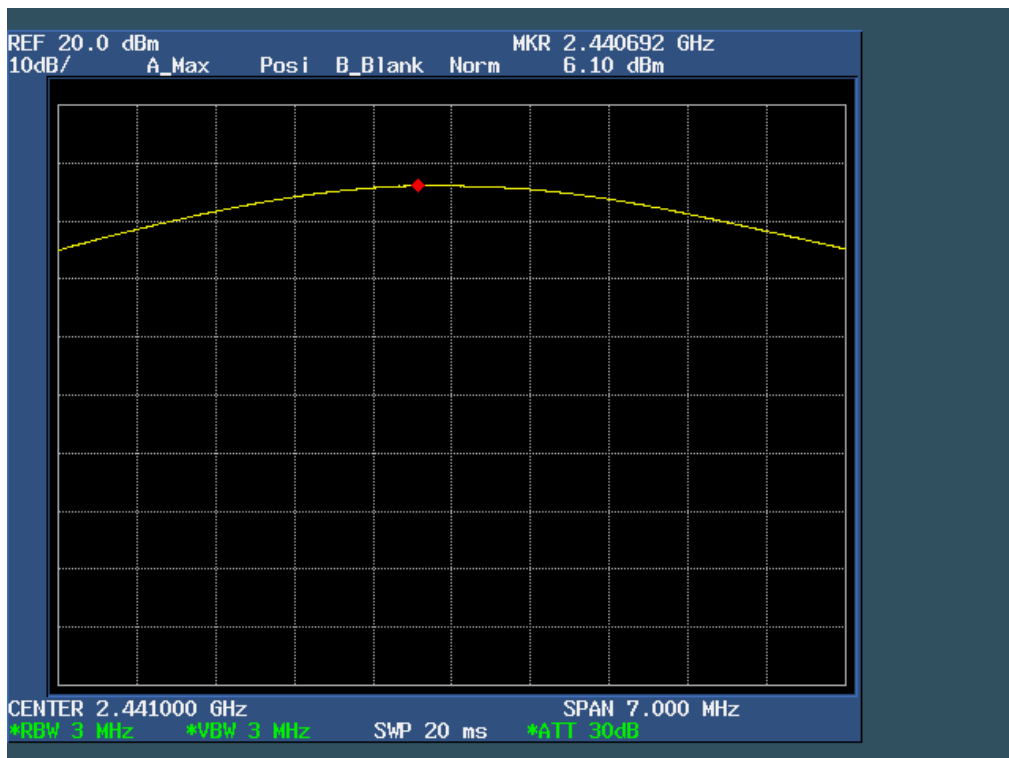

CH 78-1Mbps

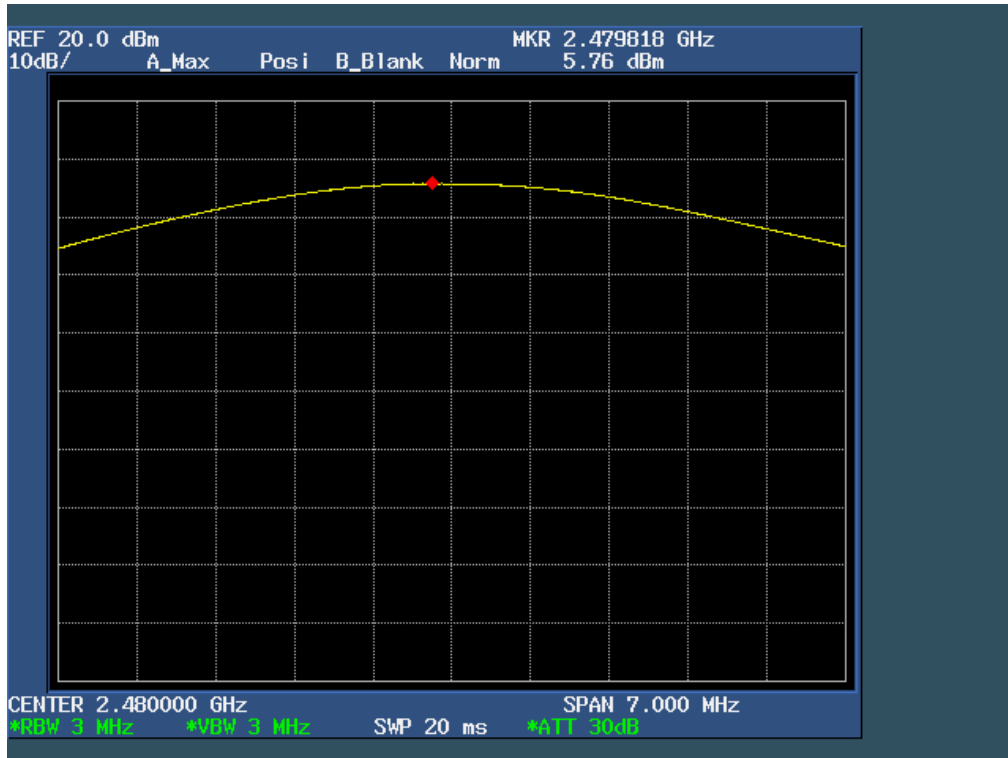

CH 00-3Mbps

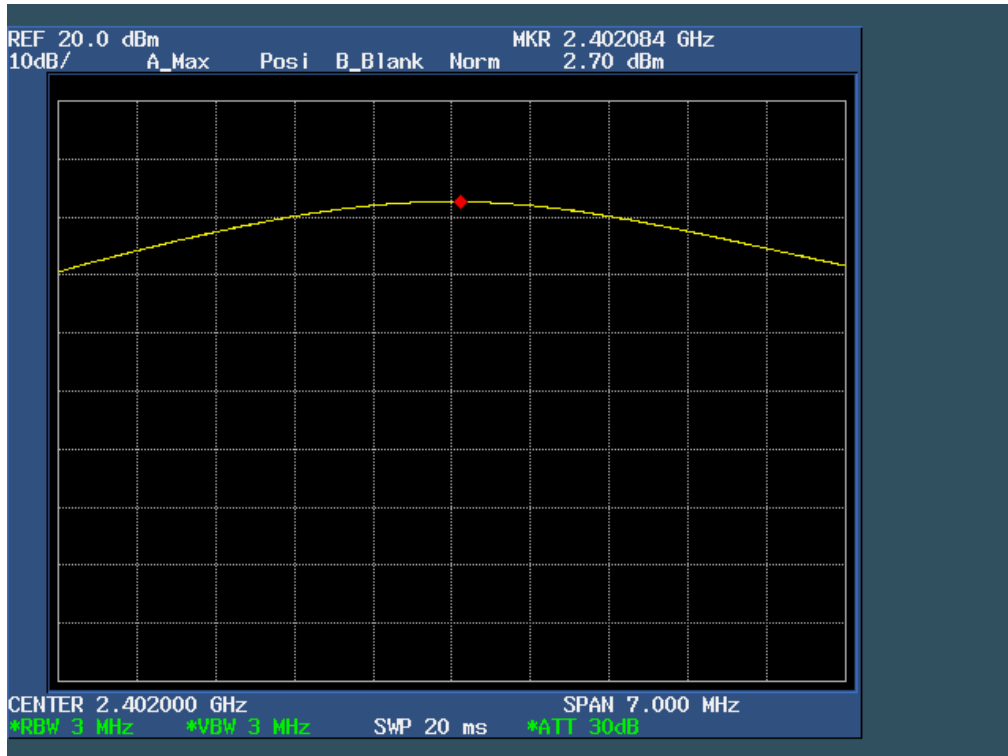

CH 39-3Mbps

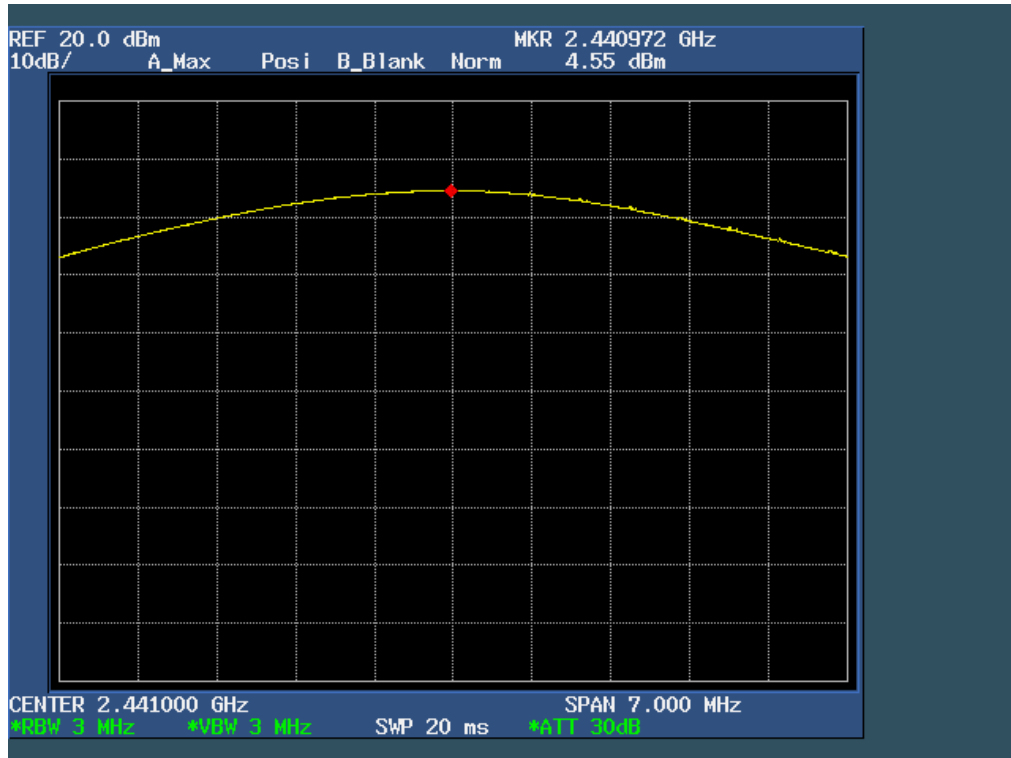

CH 78-3Mbps

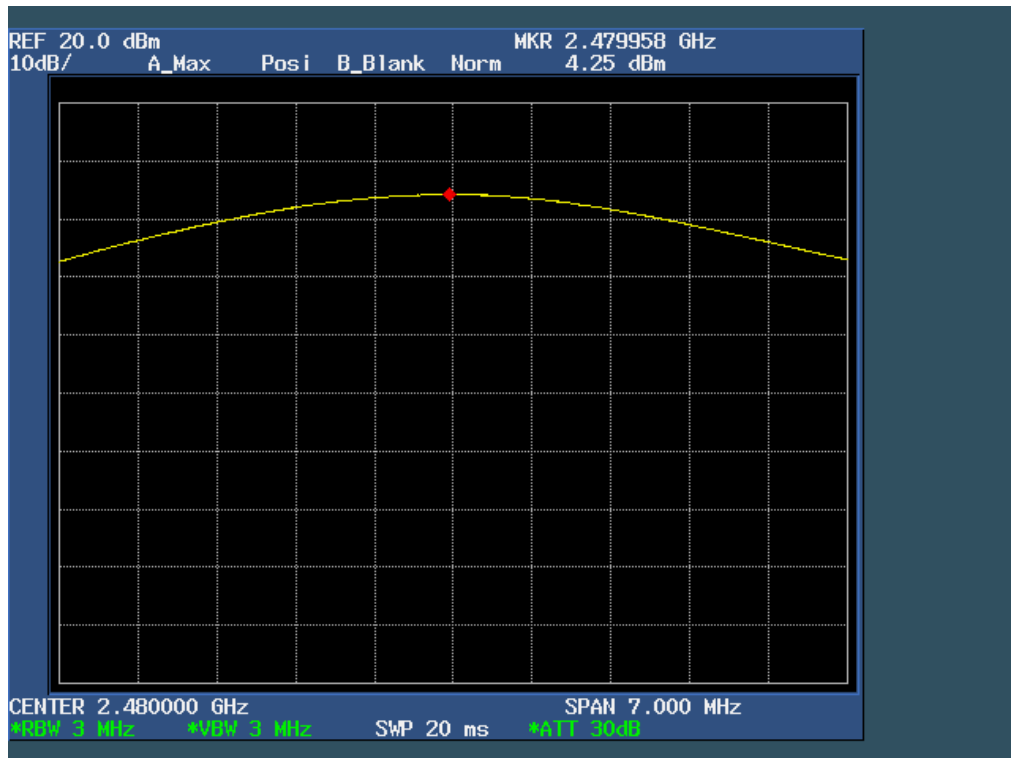

The new data:

EUT:	Reverie 4.1 Bluetooth Speaker	Model Name :	AM-BT-S01
Temperature:	26 °C	Relative Humidity:	60%
Pressure:	1010 hPa	Test Voltage :	DC 16.0 V from Adapter AC 120V/60Hz for Adapter
Test Mode :	TX		
Note: All the data rates have be tested and the worst-case as the table below.			

Test Mode	Frequency	Reading Power (dBm)	Cable Loss (dB)	Peak Output Power (dBm)	Limit (dBm)	Result
Data rate 1Mbps	2402 MHz	4.20	0.5	4.70	30	Pass
	2441 MHz	6.00	0.5	6.50	30	Pass
	2480 MHz	5.66	0.5	6.16	30	Pass
Data rate 3Mbps	2402 MHz	2.62	0.5	3.12	30	Pass
	2441 MHz	4.53	0.5	5.03	30	Pass
	2480 MHz	4.22	0.5	4.72	30	Pass

CH 00-1Mbps

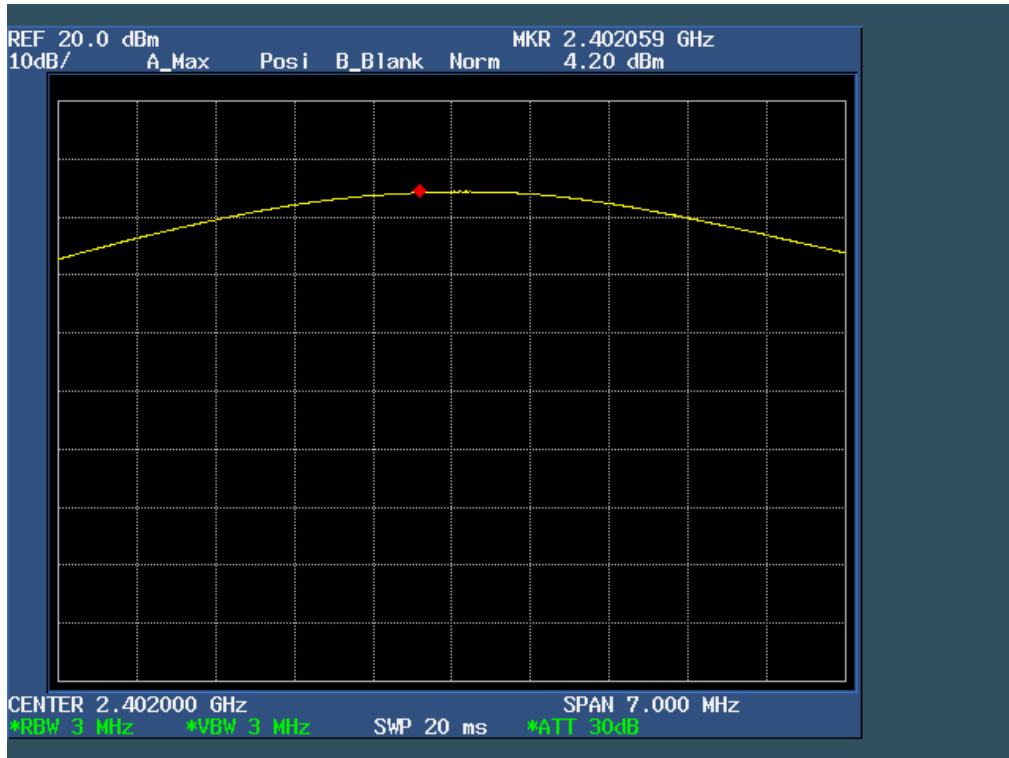

CH 39-1Mbps

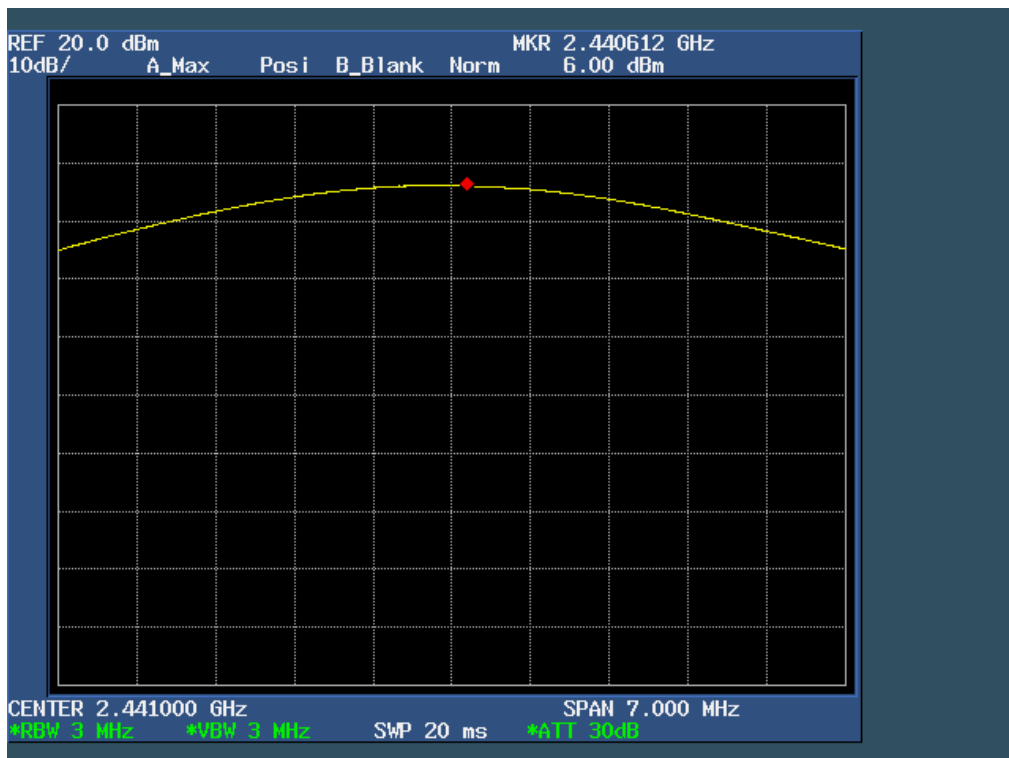

CH 78-1Mbps

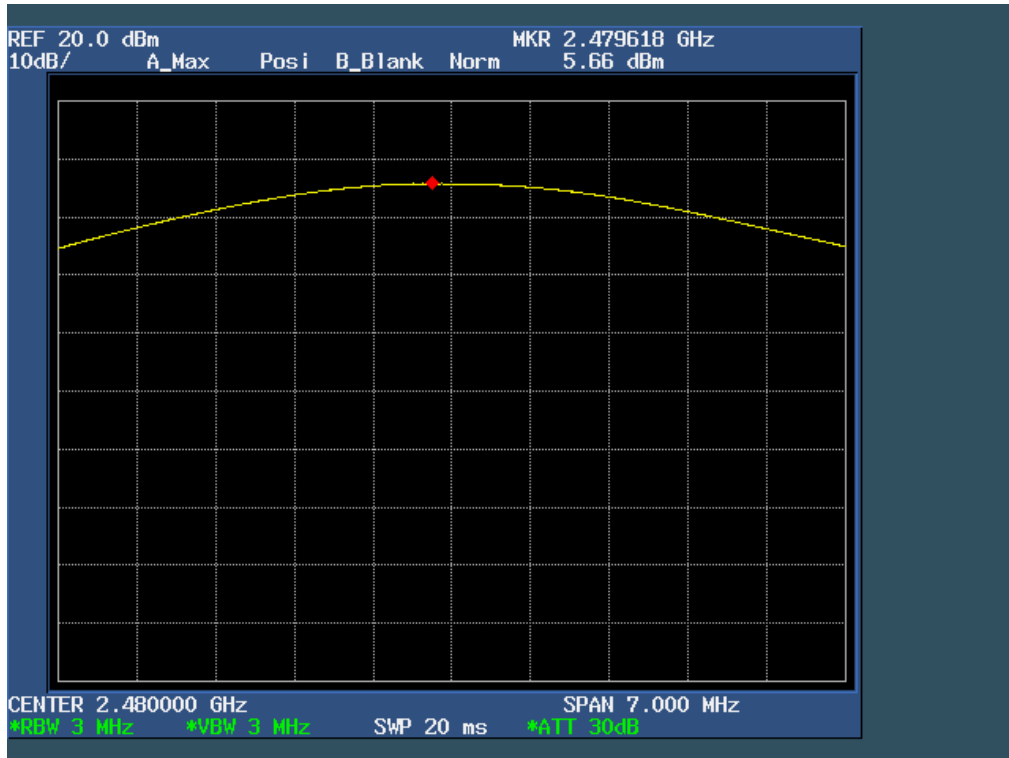

CH 00-3Mbps

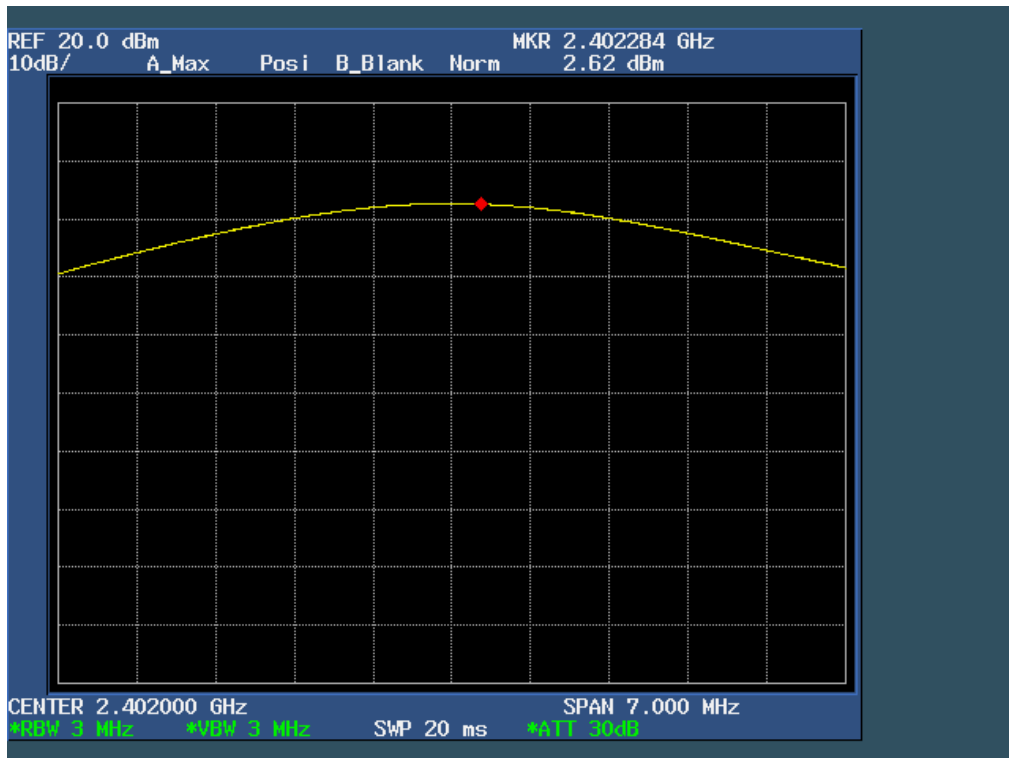

CH 39-3Mbps

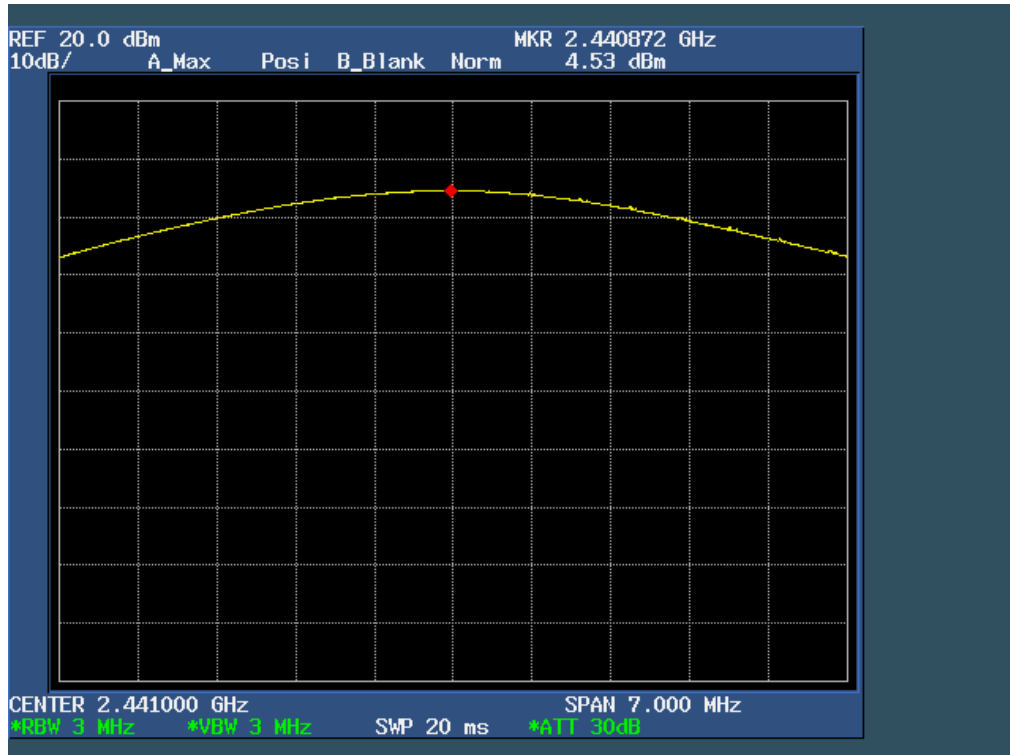

CH 78-3Mbps

