

FCC Test Report

Part 15 subpart C

Client Information:

Applicant : Ascion, LLC
Applicant add.: 341 Central Avenue Silver Creek, NY 14136

EUT Information:

EUT Name : Reverie 4.1 Bluetooth Speaker
Model No. : AM-BT-S01
Brand Name : 
FCC ID : VFK-AM-BT-S01

Prepared By:

Asia Institute Technology (Dongguan) Limited

Add. : No. 22, JinQianLing Street 3, JiTiGang Village HuangJiang Town, DongGuan, GuangDong, China.

Date of Receipt: May. 20, 2014

Date of Test: Jun. 11~17, 2014

Date of Issue: Jun. 20, 2014

Test Result: **Pass**

Test procedure used: ANSI C63.4-2009

This device described above has been tested by Asia Institute Technology (Dongguan) Limited, and the test results show that the equipment under test (EUT) is in compliance with the FCC requirements. And it is applicable only to the tested sample identified in the report.

*This test report must not be used by the client to claim product endorsement by any agency of the U.S. government.

Reviewed by:



Seal.Chen

Approved by:



Jackie.Deng

1 Contents

	Page
COVER PAGE	
1 CONTENTS	2
2 TEST SUMMARY	4
2.1 COMPLIANCE WITH FCC PART 15 SUBPART C	4
2.2 MEASUREMENT UNCERTAINTY	5
3 TEST FACILITY	6
3.1 DEVIATION FROM STANDARD	6
3.2 ABNORMALITIES FROM STANDARD CONDITIONS	6
4 GENERAL INFORMATION	7
4.1 GENERAL DESCRIPTION OF EUT	7
4.2 DESCRIPTION OF TEST CONDITIONS	9
4.3 EUT PERIPHERAL LIST	10
4.4 TEST PERIPHERAL LIST	10
5 EQUIPMENTS LIST FOR ALL TEST ITEMS	11
6 TEST RESULT	12
6.1 ANTENNA REQUIREMENT	12
6.1.1 Standard requirement.....	12
6.1.2 EUT Antenna	12
6.2 CONDUCTION EMISSIONS MEASUREMENT.....	13
6.2.1 Applied procedures / Limit.....	13
6.2.2 Test procedure	13
6.2.3 Test results	14
6.3 RADIATED EMISSIONS MEASUREMENT.....	16
6.3.1 Applied procedures / Limit.....	16
6.3.2 Test procedure	16
6.3.3 Test Result	17
6.3.4 TEST RESULTS (Restricted Bands Requirements).....	22
6.4 BANDWIDTH TEST	23
6.4.1 Applied procedures / Limit.....	23
6.4.2 Test procedure	23
6.4.3 Deviation from standard	23
6.4.4 Test setup.....	23
6.4.5 Test results	24
6.5 PEAK POWER DENSITY	27
6.5.1 Applied procedures / Limit.....	27
6.5.2 Test procedure	27
6.5.3 Deviation from standard	27
6.5.4 Test results	28



6.6	MAXIMUM PEAK OUTPUT POWER	32
6.6.1	Applied procedures / Limit.....	32
6.6.2	Test procedure	32
6.6.3	Deviation from standard	32
6.6.4	Test setup.....	32
6.6.5	Test results	33
6.7	BAND EDGE.....	36
6.7.1	Applied procedures / Limit.....	36
6.7.2	Test procedure	36
6.7.3	Deviation from standard	36
6.7.4	Test setup.....	36
6.7.5	Test results	37
6.8	CONDUCTED SPURIOUS EMISSIONS	38
6.8.1	Applied procedures / Limit.....	38
6.8.2	Test procedure	38
6.8.3	Deviation from standard	38
6.8.4	Test setup.....	38
6.8.5	Test results	39

2 Test Summary

2.1 Compliance with FCC Part 15 subpart C

Test	Test Requirement	Standard Paragraph	Result
Antenna Requirement	FCC Part 15 C:2013	Section 15.247(c)	PASS
Conduction Emissions	FCC Part 15 C:2013	Section 15.207(a)	PASS
Radiated Emissions	FCC Part 15 C:2013	Section 15.247(d)	PASS
Occupied Bandwidth	FCC Part 15 C:2013	Section 15.247(a)(2)	PASS
Peak power density	FCC Part 15 C:2013	Section 15.247(e)	PASS
Maximum Peak Output Power	FCC Part 15 C:2013	Section 15.247(b)(1)	PASS
Band edge	FCC Part 15 C:2013	Section 15.247(d)	PASS
Conducted Spurious Emissions	FCC Part 15 C:2013	Section 15.247(d)	PASS
Note: Reference to the KDB 558074 D01 DTS Meas Guidance v03r02			

2.2 Measurement Uncertainty

All measurements involve certain levels of uncertainties, The following measurements uncertainty Levels have estimated based on ANSI C63.4:2009, the maximum value of the uncertainty as below

No.	Item	Uncertainty
1	Conducted Emission Test	1.20dB
2	Radiated Emission Test	3.30dB

3 Test Facility

The test facility is recognized, certified or accredited by the following organizations:

.CNAS- Registration No: L6177

Dongguan Yaxu (AiT) technology Limited is accredited to ISO/IEC 17025:2005 general Requirements for the competence of testing and calibration laboratories (CNAS-CL01 Accreditation Criteria for the competence of testing and calibration laboratories) on Apr. 18, 2013

.FCC- Registration No: 248337

The 3m Semi-Anechoic Chamber, 3m/10m Open Area Test Site and Shielding Room of Asia Institute Technology (Dongguan) Limited have been registered by Federal Communications Commission (FCC) on Dec.19, 2012.

.Industry Canada(IC)-Registration No: IC6819A-1 & IC6819A-2

The 3m Semi-Anechoic Chamber and 3m/10m Open Area Test Site of Asia Institute Technology (Dongguan) Limited have been registered by Certification and Engineering Bureau of Industry Canada for radio equipment testing on Jun. 12, 2013.

.VCCI- Registration No: 2705

The 3m/10m Open Area Test Site, Shielding Room and 3m Chamber of Asia Institute Technology (Dongguan) Limited have been registered by Voluntary Control Council for Interference on Nov. 21, 2012. The Telecommunication Ports Conducted Disturbance Measurement of Asia Institute Technology (Dongguan) Limited have been registered by Voluntary Control Council for Interference on Sep. 06, 2011.

.TUV NORD

Asia Institute Technology (Dongguan) Limited has been assessed on Jun. 13, 2013 that it can carry out EMC tests by order and under supervision of TUV NORD.

.ITS- Registration No: TMPSHA031

Asia Institute Technology (Dongguan) Limited has been assessed and included in Intertek Shanghai TMP Program regarding Laboratory facilities and test equipment on Jul.22, 2012.

3.1 Deviation from standard

None

3.2 Abnormalities from standard conditions

None

4 General Information

4.1 General Description of EUT

Manufacturer:	GIGATEK ELECTRONICS (DongGuan) CO.,LTD	
Manufacturer Address:	IN Yang Industrial, Zhangyang District, Zhangmutou Town, Dongguan City, Guandong, China 523636	
EUT Name:	Reverie 4.1 Bluetooth Speaker	
Model No:	AM-BT-S01	
Operation frequency:	2402 MHz to 2480 MHz	
NUMBER OF CHANNEL:	Bluetooth 4.0	40
Modulation Technology:	Bluetooth 4.0	GFSK(1Mbps)
Antenna Type:	dipole	
Antenna Gain:	max 2.11dBi	
Brand Name:		
Serial No:	N/A	
Power Supply Range:	Input: 100-240Vac, 50/60Hz, 1.5A Output: DC 16V 3.2A	
Power Supply:	DC 16.0V from Adapter,AC 120V/60Hz for Adapter	
Power Cord:	N/A	
Output power (max) :	Bluetooth 4.0	1Mbps: 6.08dBm
Note:		
	1.	For a more detailed features description, please refer to the manufacturer's specifications or the User's Manual.

Description of Channel:			
Channel	Frequency (MHz)	Channel	Frequency (MHz)
00	2402	20	2442
01	2404	21	2444
02	2406	22	2446
03	2408	23	2448
04	2410	24	2450
05	2412	25	2452
06	2414	26	2454
07	2416	27	2456
08	2418	28	2458
09	2420	29	2460
10	2422	30	2462
11	2424	31	2464
12	2426	32	2466
13	2428	33	2468
14	2430	34	2470
15	2432	35	2472
16	2434	36	2474
17	2436	37	2476
18	2438	38	2478
19	2440	39	2480

4.2 Description of Test conditions

- (1) EUT was tested in normal configuration (Please See following Block diagram)

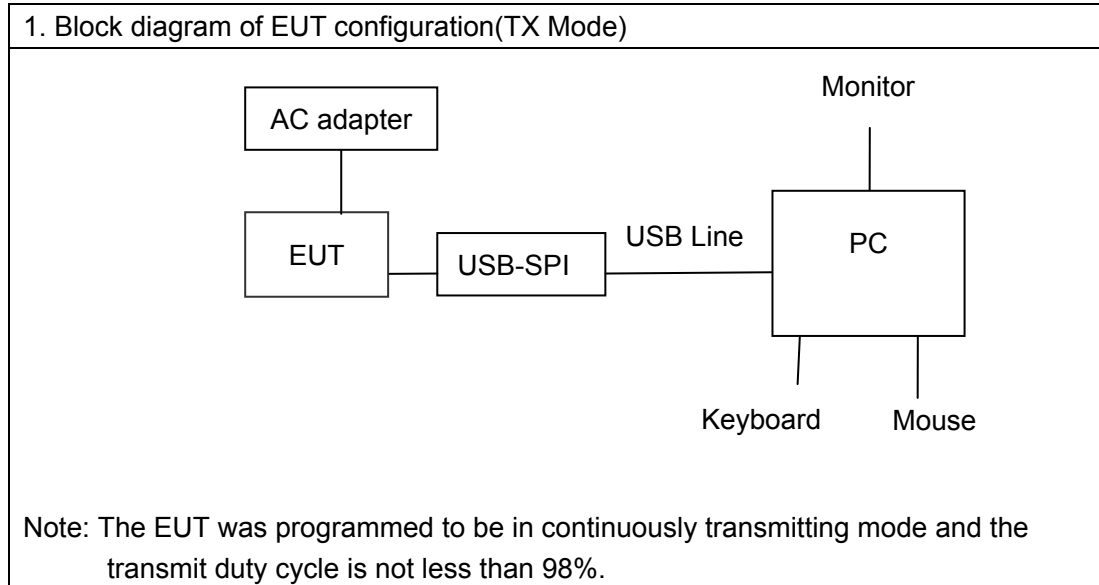

- (2) E.U.T. test conditions:

15.31(e): For intentional radiators, measurements of the variation of the input power or the radiated signal level of the fundamental frequency component of the emission, as appropriate, shall be performed with the supply voltage varied between 85% and 115% of the nominal rated supply voltage. For battery operated equipment, the equipment tests shall be performed using a new battery.

- (3) Test frequencies:

According to the 15.31(m) Measurements on intentional radiators or receivers, other than TV broadcast receivers, shall be performed and. If required reported for each band in which the device can be operated with the device operating at the number of frequencies in each band specified in the following table:

Frequency range over which device operates	Number of frequencies	Location in the range of operation
1 MHz or less	1	Middle
1 to 10 MHz	2	1 near top and 1 near bottom
More than 10 MHz	3	1 near top, 1 near middle and 1 near bottom

- (4) Frequency range of radiated measurements:

According to the 15.33, the test range will be up to the tenth harmonic of the highest fundamental frequency.

4.3 EUT Peripheral List

No.	Equipment	Manufacturer	Model No.	Serial No.	Power cord	signal cable
1	N/A	N/A	N/A	N/A	N/A	N/A

4.4 Test Peripheral List

No.	Equipment	Manufacturer	EMC Compliance	Model No.	Serial No.	Power cord	signal cable
1	Personal computer	H P	CE 、 FCC	DX2310	CNG8250MZ3	1.8m/unshielded /detachable	N/A
2	Keyboard	DELL	CE	SK-8115	CN-ONM432-71616-81M-OLK B	N/A	1.5m/unshielded /undetachable
3	Mouse	Microsoft	CE	X800898	30603	N/A	1.5m/unshielded /undetachable
4	Monitor	DELL	CE	T980KAC DK21SN	TWS20006045	1.8m/unshielded /detachable	1.8m/shielded /detachable
5	USB-SPI	CSR	N/A	N/A	N/A	N/A	0.8m/shielded /detachable

5 Equipments List for All Test Items

No	Test Equipment	Manufacturer	Model No	Serial No	Cal. Date	Cal. Due Date
1	Spectrum Analyzer	ADVANTEST	R3182	150900201	2013.06.27	2014.06.26
2	EMI Measuring Receiver	R&S	ESR	101160	2014.04.22	2015.04.21
3	Low Noise Pre Amplifier	Tsj	MLA-10K01-B01-27	1205323	2013.06.27	2014.06.26
4	Low Noise Pre Amplifier	Tsj	MLA-0120-A02-34	2648A04738	2013.12.02	2014.12.01
5	TRILOG Super Broadband test Antenna	SCHWARZBECK	VULB9160	9160-3206	2013.12.03	2014.12.02
6	Broadband Horn Antenna	SCHWARZBECK	BBHA9120D	452	2013.12.03	2014.12.02
7	SHF-EHF Horn	SCHWARZBECK	BBHA9170	BBHA9170367	2013.12.08	2013.12.07
8	50Ω Coaxial Switch	Anritsu	MP59B	6200264416	2013.09.26	2014.09.25
9	EMI Test Receiver	R&S	ESCI	100124	2013.06.27	2014.06.26
10	LISN	Kyoritsu	KNW-242	8-837-4	2013.06.27	2014.06.26
11	LISN	Kyoritsu	KNW-407	8-1789-3	2013.06.27	2014.06.26
12	50Ω Coaxial Switch	Anritsu	MP59B	6200264417	2013.09.26	2014.09.25
13	Loop Antenna	ARA	PLA-1030/B	1029	2014.03.19	2015.03.18
14	Power Meter	R&S	NRVS	101336	2013.06.27	2014.06.26
15	Power Sensor	R&S	URV5-Z7	100077	2013.06.27	2014.06.26

6 Test Result

6.1 Antenna Requirement

6.1.1 Standard requirement

15.203 requirement: For intentional device, according to 15.203: an intentional radiator shall be designed to ensure that no antenna other than that furnished by the responsible party shall be used with the device.

15.247(c) (1)(i) requirement: (i) Systems operating in the 2400-2483.5 MHz band that is used exclusively for fixed. Point-to-point operations may employ transmitting antennas with directional gain greater than 6dBi provided the maximum conducted output power of the intentional radiator is reduced by 1 dB for every 3 dB that the directional gain of the antenna exceeds 6dBi.

6.1.2 EUT Antenna

The antenna is fixed in the EUT by glue and no consideration of replacement. Antenna gain is max 2.11dbi from 2.4GHz to 2.5GHz.

6.2 Conduction Emissions Measurement

6.2.1 Applied procedures / Limit

Frequency of Emission (MHz)	Conducted Limit (dB μ V)	
	Quasi-peak	Average
0.15-0.5	66 to 56 *	56 to 46 *
0.5-5	56	46
5-30	60	50

Note: Decreases with the logarithm of the frequency.

6.2.2 Test procedure

EUT was placed upon a wooden test table 0.8m above the horizontal metal reference plane and 0.4m from the vertical ground plane, and it was connected to an AMN. The closest distance between the boundary of the EUT and the surface of the AMN is 0.8m. All peripherals were connected to another AMN, and placed at a distance of 10cm from each other. A spectrum and receiver was connected to the RF output port of the AMN. Both average and quasi-peak value were detected.

6.2.3 Test results

EUT:	Reverie 4.1 Bluetooth Speaker	Model Name. :	AM-BT-S01
Temperature:	26 °C	Relative Humidity:	54%
Pressure:	1010hPa	Test Date :	2014-06-11
Test Mode:	TX	Phase :	Line
Test Voltage :	DC 16.0V from Adapter , AC 120V/60Hz for Adapter		

Frequency (MHz)	Meter Reading (dBμV)	Factor(dB)	Emission Level (dBμV)	Limits (dBμV)	Margin (dB)	Detector
0.1539	38.44	11.84	50.28	65.78	-15.50	Quasi-Peak
0.1539	21.66	11.84	33.50	55.78	-22.28	Average
*0.5100	38.70	10.01	48.71	56.00	-7.29	Quasi-Peak
0.5100	26.52	10.01	36.53	46.00	-9.47	Average
13.0300	41.90	1.35	43.25	60.00	-16.75	Quasi-Peak
12.9580	38.76	1.35	40.11	50.00	-9.89	Average

Remark:

- Factor = Insertion Loss + Cable Loss.
- '*' means the worst case.

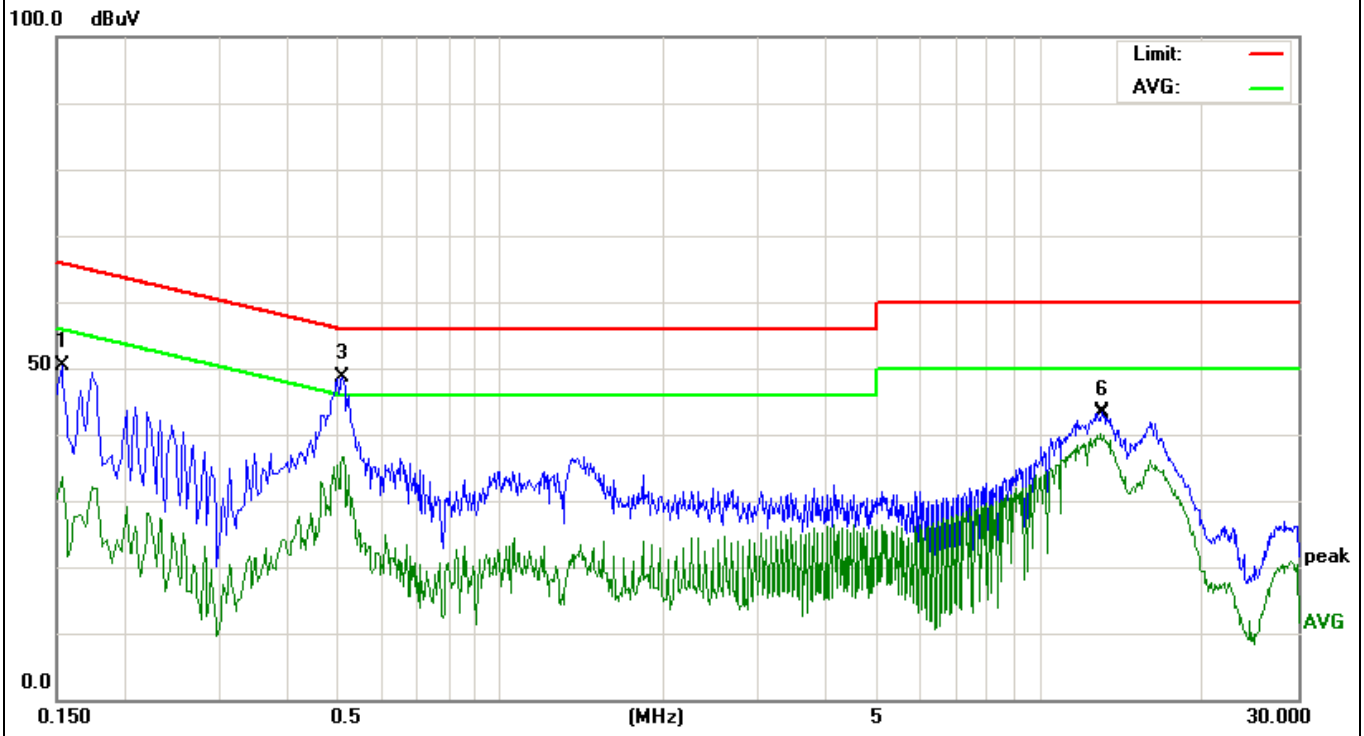

EUT:	Reverie 4.1 Bluetooth Speaker	Model Name. :	AM-BT-S01
Temperature:	26 °C	Relative Humidity:	54%
Pressure:	1010hPa	Test Date :	2014-06-11
Test Mode:	TX	Phase :	Neutral
Test Voltage :	DC 16.0V from Adapter , AC 120V/60Hz for Adapter		

Frequency (MHz)	Meter Reading (dBμV)	Factor(dB)	Emission Level (dBμV)	Limits (dBμV)	Margin (dB)	Detector
0.1500	42.22	11.94	54.16	65.99	-11.83	Quasi-Peak
0.1539	22.60	11.84	34.44	55.78	-21.34	Average
*0.5100	39.65	10.01	49.66	56.00	-6.34	Quasi-Peak
0.5060	28.92	10.01	38.93	46.00	-7.07	Average
13.3220	42.92	1.36	44.28	60.00	-15.72	Quasi-Peak
12.8300	39.10	1.35	40.45	50.00	-9.55	Average

Remark:

- Factor = Insertion Loss + Cable Loss.
- ** means the worst case.

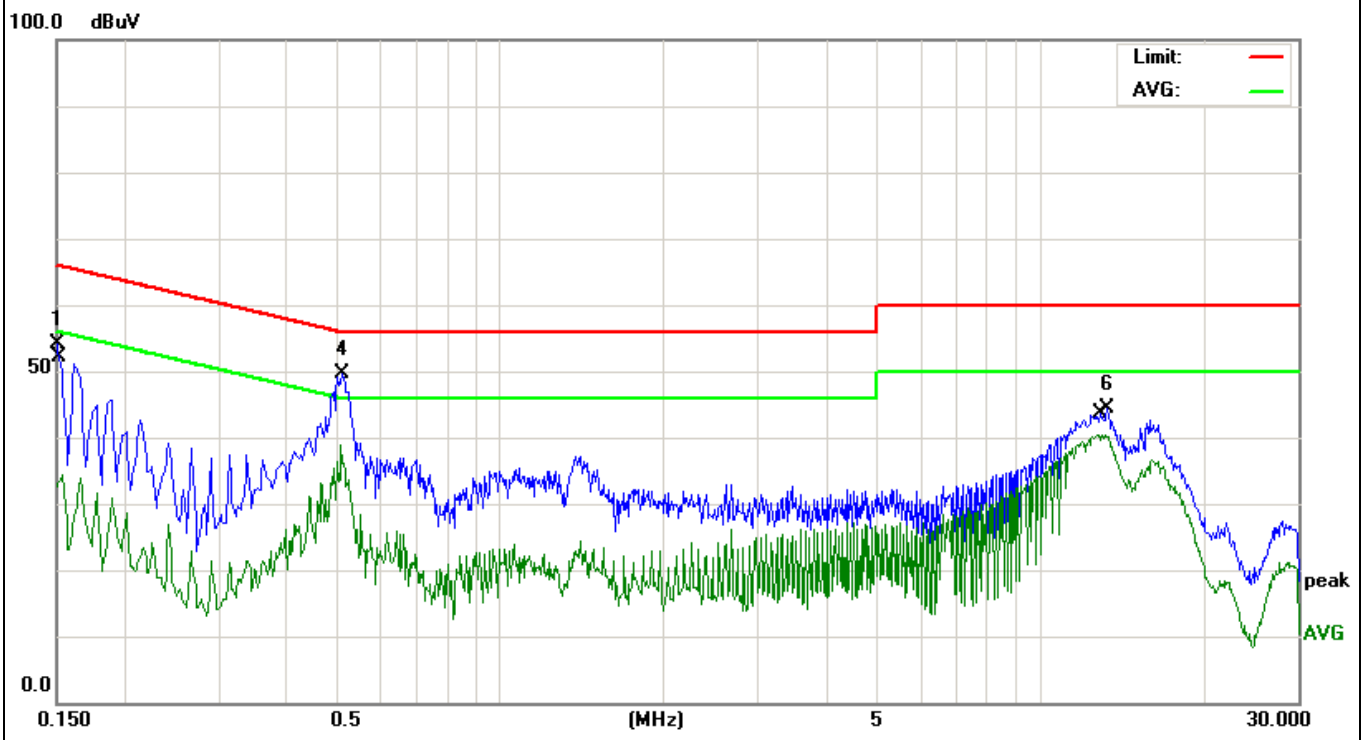

6.3 Radiated Emissions Measurement

6.3.1 Applied procedures / Limit

15.247(d) In any 100 kHz bandwidth outside the frequency band in which the spread spectrum or digitally modulated intentional radiator is operating, the radio frequency power that is produced by the intentional radiator shall be at least 20 dB below that in the 100 kHz bandwidth within the band that contains the highest level of the desired power, based on either an RF conducted or a radiated measurement, provided the transmitter demonstrates compliance with the peak conducted power limits. If the transmitter complies with the conducted power limits based on the use of RMS averaging over a time interval, as permitted under paragraph (b)(3) of this section, the attenuation required under this paragraph shall be 30 dB instead of 20 dB. Attenuation below the general limits specified in Section 15.209(a) is not required. In addition, radiated emissions which fall in the restricted bands, as defined in Section 15.205(a), must also comply with the radiated emission limits specified in Section 15.209(a) (see Section 15.205(c)).

Frequency of Emission (MHz)	Field Strength		Measurement Distance (meters)
	$\mu\text{V/m}$	$\text{dB}\mu\text{V/m}$	
0.009-0.49	2400/F(kHz)		300
0.49-1.705	24000/F(kHz)		30
1.705-30	30		30
30-88	100	40	3
88-216	150	43.5	3
216-960	200	46	3
Above 960	500	54	3

6.3.2 Test procedure

EUT was placed upon a wooden test table which was placed on the turn table 0.8m above the horizontal metal ground plane, and operating in the mode as mentioned above. A receiving antenna was placed 3m away from the EUT. During testing, turn around the turn table and move the antenna from 1m to 4m to find the maximum field-strength reading. All peripherals were placed at a distance of 10cm between each other. Both horizontal and vertical antenna polarities were tested and performed pretest to three orthogonal axis. The worst case emissions were reported.

6.3.3 Test Result

Radiated Emissions Test Data Below 30MHz

EUT:	Reverie 4.1 Bluetooth Speaker	Model Name :	AM-BT-S01
Temperature:	25 °C	Test Data	2014-06-12
Pressure:	1005 hPa	Relative Humidity:	60%
Test Mode :	TX(1Mbps)	Test Voltage :	DC 16.0 V from Adapter AC 120V/60Hz for Adapter
Measurement Distance	3 m	Frenqucy Range	9KHz to 30MHz
RBW/VBW	9KHz~150KHz/RB 200Hz for QP, 150KHz~30MHz/RB 9KHz for QP		

No emission found between lowest internal used/generated frequencies to 30MHz.

Radiated Emissions Test Data Below 1GHz

EUT:	Reverie 4.1 Bluetooth Speaker	Model Name :	AM-BT-S01
Temperature:	25 °C	Test Data	2014-06-12
Pressure:	1010 hPa	Relative Humidity:	60%
Test Mode :	TX(1Mbps)	Test Voltage :	DC 16.0V from Adapter , AC 120V/60Hz for Adapter
Measurement Distance	3 m	Frenqucy Range	30MHz to 1GHz
RBW/VBW	100KHz / 300KHz for spectrum, RBW=120KHz for receiver.		

(a) Antenna polarization: Horizontal

Frequency (MHz)	Reading Level (dBuV)	Correct Factor (dB)	Measure Level (dBuV/m)	Limit (dBuV/m)	Margin (dB)	Detector Type
*31.3992	33.14	-14.84	18.30	40.00	-21.70	QUASPEAK
64.2074	29.36	-17.84	11.52	40.00	-28.48	QUASPEAK
87.4177	31.24	-16.61	14.63	40.00	-25.37	QUASPEAK
206.3976	27.50	-15.08	12.42	43.50	-31.08	QUASPEAK
243.3772	24.51	-11.66	12.85	46.00	-33.15	QUASPEAK
414.7223	25.96	-6.83	19.13	46.00	-26.87	QUASPEAK

(b) Antenna polarization: vertical

Frequency (MHz)	Reading Level (dBuV)	Correct Factor (dB)	Measure Level (dBuV/m)	Limit (dBuV/m)	Margin (dB)	Detector Type
31.9546	44.48	-16.79	27.69	40.00	-12.31	QUASPEAK
50.4089	39.19	-19.03	20.16	40.00	-19.84	QUASPEAK
*73.3593	49.05	-20.04	29.01	40.00	-10.99	QUASPEAK
92.1388	34.50	-17.37	17.13	43.50	-26.37	QUASPEAK
130.8369	24.34	-16.03	8.31	43.50	-35.19	QUASPEAK
182.5592	23.76	-14.63	9.13	43.50	-34.37	QUASPEAK

Note: '*' means the worst case

Measurement Level = Reading Level + Factor

Factor=Ant Factor + Cable Loss

Radiated Emissions Test Data Above 1GHz

EUT:	Reverie 4.1 Bluetooth Speaker	Model Name :	AM-BT-S01
Temperature:	25 °C	Test Data	2014-06-12
Pressure:	1010 hPa	Relative Humidity:	60%
Test Mode :	TX(1Mbps)	Test Voltage :	DC 16.0V from Adapter , AC 120V/60Hz for Adapter
Measurement Distance	3 m	Frenqucy Range	1GHz to 25GHz
RBW/VBW	1MHz/1MHz for Peak, 1MHz/10Hz for Average.		

(a) Antenna polarization: Horizontal

Frequency (MHz)	Reading Level (dBuV)	Correct Factor (dB)	Measure Level (dBuV/m)	Limit (dBuV/m)	Margin (dB)	Detector Type
2400.000	50.01	-5.70	44.31	74.00	-29.69	PEAK
2400.000	39.18	-5.70	33.48	54.00	-20.52	AVERAGE
4804.000	60.03	5.06	65.09	74.00	-8.91	PEAK
*4804.000	42.56	5.06	47.62	54.00	-6.38	AVERAGE
7206.000	44.14	7.03	51.17	74.00	-22.83	PEAK
7206.000	34.01	7.03	41.04	54.00	-12.96	AVERAGE

(b) Antenna polarization: Vertical

Frequency (MHz)	Reading Level (dBuV)	Correct Factor (dB)	Measure Level (dBuV/m)	Limit (dBuV/m)	Margin (dB)	Detector Type
2400.000	53.46	-5.70	47.76	74.00	-26.24	PEAK
2400.000	42.70	-5.70	37.00	54.00	-17.00	AVERAGE
4804.000	59.31	5.06	64.37	74.00	-9.63	PEAK
*4804.000	42.75	5.06	47.81	54.00	-6.19	AVERAGE
7206.000	42.35	7.03	49.38	74.00	-24.62	PEAK
7206.000	32.48	7.03	39.51	54.00	-14.49	AVERAGE

Note: '*' means the worst case

8~25GHz at least have 20dB margin. No recording in the test report.

Measurement Level = Reading Level + Factor

Factor=Ant Factor + Cable Loss

Low Channel 00: 2402 MHz

Data rate: 1Mbps

(a) Antenna polarization: Horizontal

Frequency (MHz)	Reading Level (dBuV)	Correct Factor (dB)	Measure Level (dBuV/m)	Limit (dBuV/m)	Margin (dB)	Detector Type
4880.000	60.34	5.14	65.48	74.00	-8.52	PEAK
*4880.000	43.16	5.14	48.30	54.00	-5.70	AVERAGE
7320.000	40.19	7.52	47.71	74.00	-26.29	PEAK
7320.000	25.09	7.52	32.61	54.00	-21.39	AVERAGE

(b) Antenna polarization: Vertical

Frequency (MHz)	Reading Level (dBuV)	Correct Factor (dB)	Measure Level (dBuV/m)	Limit (dBuV/m)	Margin (dB)	Detector Type
4880.000	57.82	5.14	62.96	74.00	-11.04	PEAK
*4880.000	41.63	5.14	46.77	54.00	-7.23	AVERAGE
7320.000	39.45	7.52	46.97	74.00	-27.03	PEAK
7320.000	28.14	7.52	35.66	54.00	-18.34	AVERAGE

Note: '*' means the worst case

8~25GHz at least have 20dB margin. No recording in the test report.

Measurement Level = Reading Level + Factor

Factor=Ant Factor + Cable Loss

Middle Channel 19: 2440 MHz

Data rate: 1Mbps

(a) Antenna polarization: Horizontal

Frequency (MHz)	Reading Level (dBuV)	Correct Factor (dB)	Measure Level (dBuV/m)	Limit (dBuV/m)	Margin (dB)	Detector Type
2483.500	47.35	-4.98	42.37	74.00	-31.63	PEAK
2483.500	32.05	-4.98	27.07	54.00	-26.93	AVERAGE
4960.000	50.37	5.22	55.59	74.00	-18.41	PEAK
*4960.000	35.50	5.22	40.72	54.00	-13.28	AVERAGE
7440.000	36.23	8.06	44.29	74.00	-29.71	PEAK
7440.000	23.65	8.06	31.71	54.00	-22.29	AVERAGE

(b) Antenna polarization: Vertical

Frequency (MHz)	Reading Level (dBuV)	Correct Factor (dB)	Measure Level (dBuV/m)	Limit (dBuV/m)	Margin (dB)	Detector Type
2483.500	46.27	-4.98	41.29	74.00	-32.71	PEAK
2483.500	32.23	-4.98	27.25	54.00	-26.75	AVERAGE
4960.000	48.05	5.22	53.27	74.00	-20.73	PEAK
*4960.000	34.31	5.22	39.53	54.00	-14.47	AVERAGE
7440.000	36.18	8.06	44.24	74.00	-29.76	PEAK
7440.000	22.33	8.06	30.39	54.00	-23.61	AVERAGE

Note: '*' means the worst case

8~25GHz at least have 20dB margin. No recording in the test report.

Measurement Level = Reading Level + Factor

Factor=Ant Factor + Cable Loss

Low Channel 39: 2480 MHz

Data rate: 1Mbps

6.3.4 TEST RESULTS (Restricted Bands Requirements)

EUT:	Reverie 4.1 Bluetooth Speaker	Model Name :	AM-BT-S01
Temperature:	25 °C	Test Data	2014-06-12
Pressure:	1010 hPa	Relative Humidity:	60%
Test Mode :	TX(1Mbps)	Test Voltage :	DC 16.0V from Adapter , AC 120V/60Hz for Adapter
Note:	<p>1. The transmitter was setup to transmit at the lowest channel. Then the field strength was measured at 2310-2390 MHz.</p> <p>2. The transmitter was setup to transmit at the highest channel. Then the field strength was measured at 2483.5-2500 MHz.</p>		

Test Mode	Ant.Pol. H/V	Freq. (MHz)	Reading		Ant/CF CF(dB)	Act		Limit	
			Peak (dBuv)	AV (dBuv)		Peak (dBuv/m)	AV (dBuv/m)	Peak (dBuv/m)	AV (dBuv/m)
TX Data rate 1Mbps	H	2390.00	49.48	39.07	-5.79	43.69	33.28	74.00	54.00
	V	2390.00	53.34	42.78	-5.79	47.55	36.99	74.00	54.00
	H	2483.50	47.35	32.05	-4.98	42.37	27.07	74.00	54.00
	V	2483.50	46.27	32.23	-4.98	41.29	27.25	74.00	54.00

6.4 BANDWIDTH TEST

6.4.1 Applied procedures / Limit

15.247(a) (2) Systems using digital modulation techniques may operate in the 902 - 928 MHz, 2400 - 2483.5 MHz, and 5725 - 5850 MHz bands. The minimum 6 dB bandwidth shall be at least 500 kHz.

6.4.2 Test procedure

- a. The testing follows FCC KDB publication No. 558074 D01 DTS Meas. Guidance v03r02
- b. The EUT was directly connected to the spectrum analyzer and antenna output port as show in the block diagram below.
- c. Spectrum Setting: RBW= 100KHz, VBW $\cong 3 \times$ RBW, Sweep time = Auto.

6.4.3 Deviation from standard

No deviation.

6.4.4 Test setup

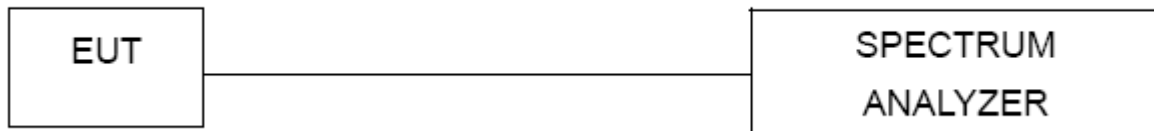

6.4.5 Test results

EUT:	Reverie 4.1 Bluetooth Speaker	Model Name :	AM-BT-S01
Temperature:	26 °C	Relative Humidity:	53%
Pressure:	1010 hPa	Test Power :	DC 16.0V from Adapter , AC 120V/60Hz for Adapter
Test Mode :	TX(1Mbps)		

Test Mode	Test Channel	Frequency (MHz)	6 dB Bandwidth (KHz)	Limit (kHz)
Data rate 1Mbps	CH00	2402	508	≅ 500
	CH19	2440	506	≅ 500
	CH39	2480	506	≅ 500

(1Mbps)
The Lowest Channel 00: 2402 MHz

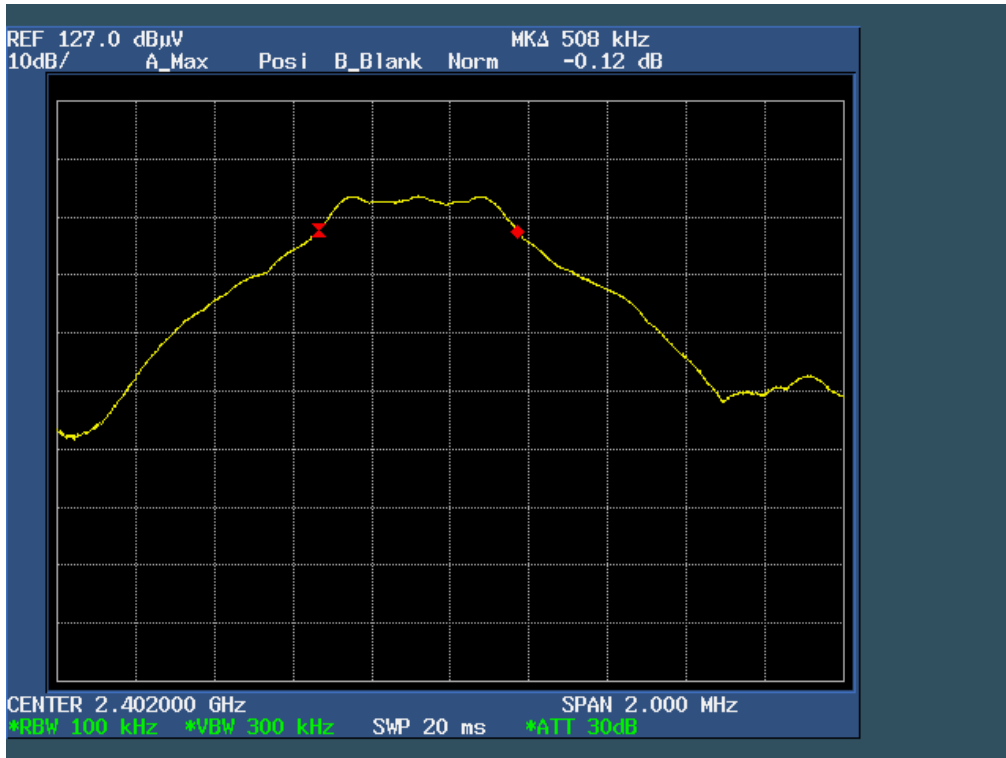

(1Mbps)
The Middle Channel 19: 2440 MHz

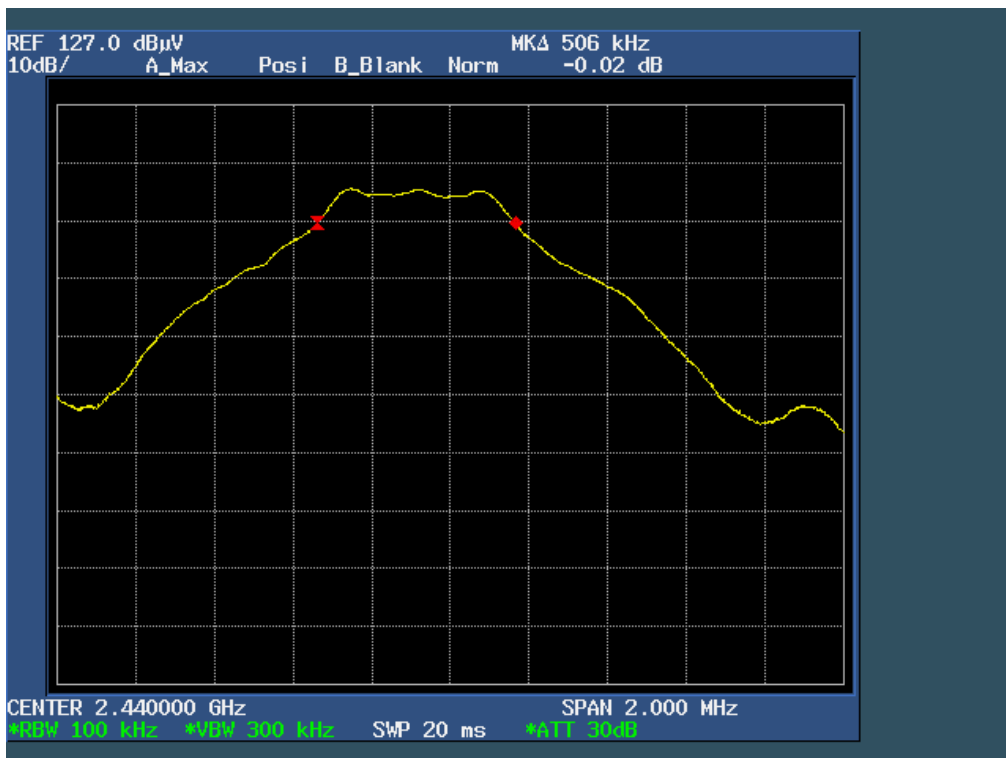

(1Mbps)
The High Channel 39: 2480MHz

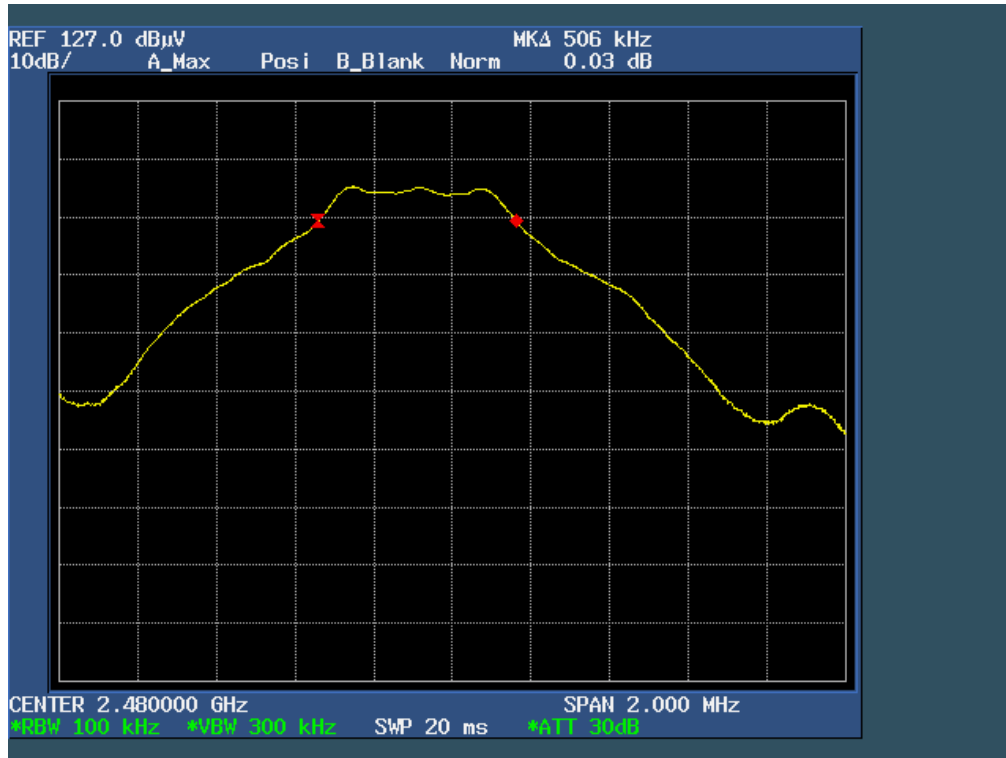

6.5 Peak Power Density

6.5.1 Applied procedures / Limit

15.247(a) (e) For digitally modulated systems, the power spectral density conducted from the intentional radiator to the antenna shall not be greater than 8 dBm in any 3 kHz band during any time interval of continuous transmission. This power spectral density shall be determined in accordance with the provisions of paragraph (b) of this section. The same method of determining the conducted output power shall be used to determine the power spectral density.

6.5.2 Test procedure

- a. The testing follows Measurement procedure 10.2 Method PKPSD of FCC KDB publication No. 558074 D01 DTS Meas. Guidance v03r02
- b. The EUT was directly connected to the spectrum analyzer and antenna output port as show in the block diagram below.
- c. Connected the antenna port to the Spectrum Analyzer, set the Spectrum Analyzer as $3\text{kHz} \leq \text{RBW} \leq 100\text{kHz}$, $\text{VBW} \geq 3 \times \text{RBW}$ kHz, Sweep time=Auto.

6.5.3 Deviation from standard

No deviation.

6.5.4 Test results

EUT:	Reverie 4.1 Bluetooth Speaker	Model Name :	AM-BT-S01
Temperature:	24 °C	Relative Humidity:	53%
Pressure:	1010 hPa	Test Power :	DC 16.0V from Adapter , AC 120V/60Hz for Adapter
Test Mode :	TX(1Mbps)		

Test Mode	Channel frequency (MHz)	Reading Power Density		Cable loss (dB)	Power Density(dBm)		Limit (dBm)	Result
		PSD/100kHz (dBm)	PSD/3kHz (dBm)		PSD/100kHz	PSD/3kHz		
TX (1Mbps)	2402	4.05	-7.78	0.5	4.55	-7.28	8	Pass
	2440	5.92	-5.93	0.5	6.42	-5.43	8	Pass
	2480	5.60	-6.14	0.5	6.10	-5.64	8	Pass

PSD 100kHz (1Mbps)
The Lowest Channel 00: 2402MHz

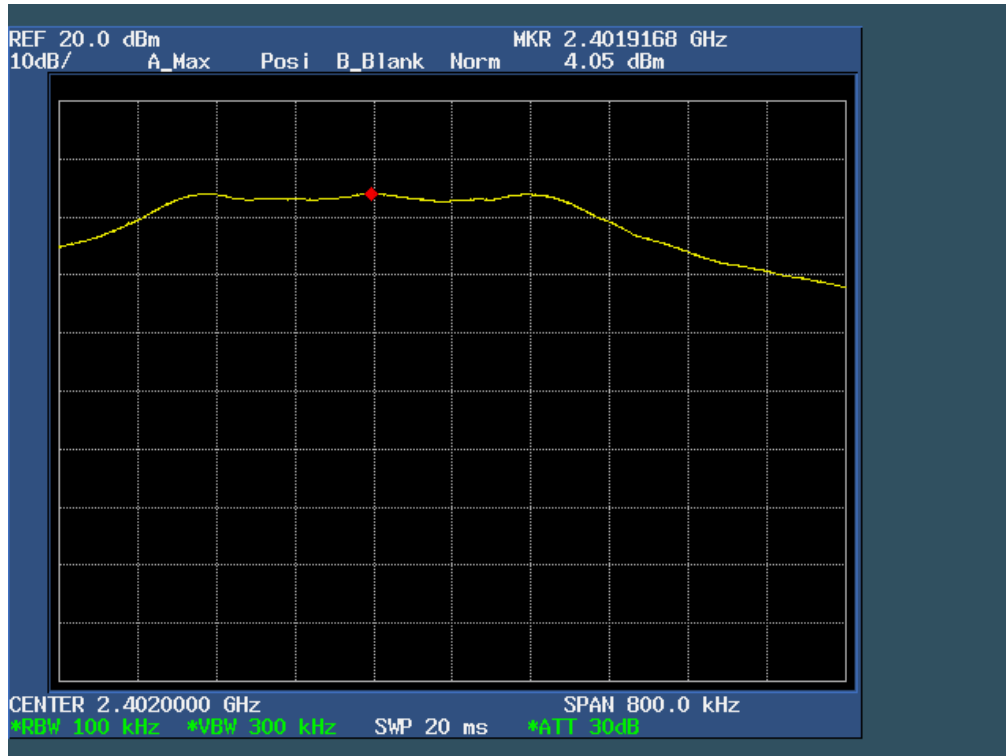

PSD 100kHz (1Mbps)
The Middle Channel 19: 2440MHz

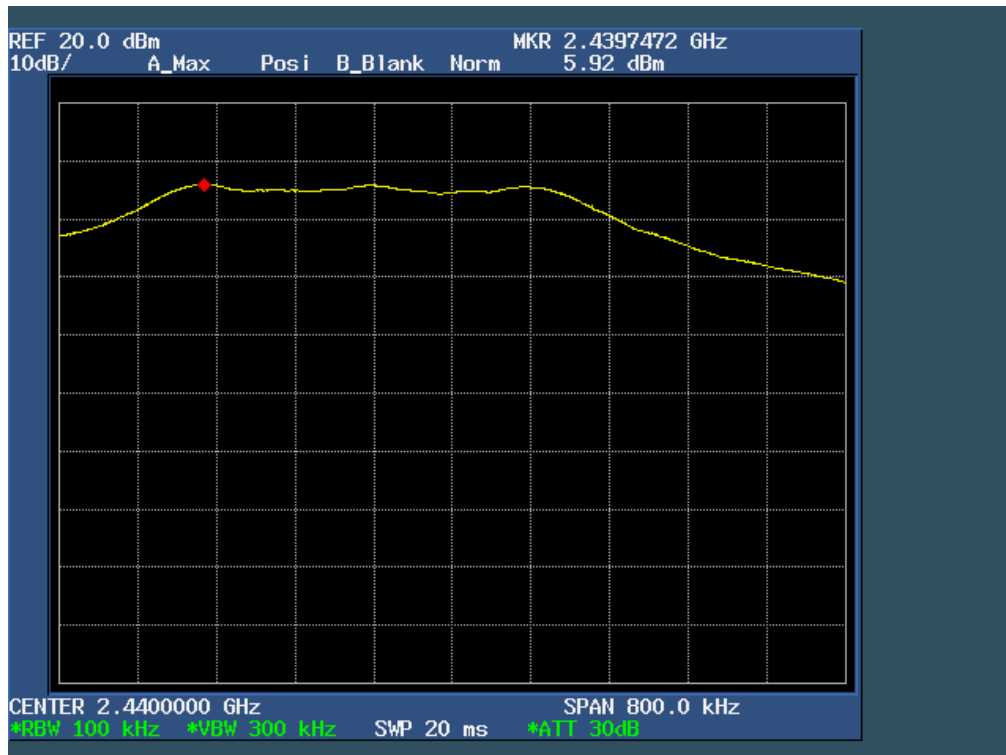

PSD 100kHz (1Mbps)
The High Channel 39: 2480MHz

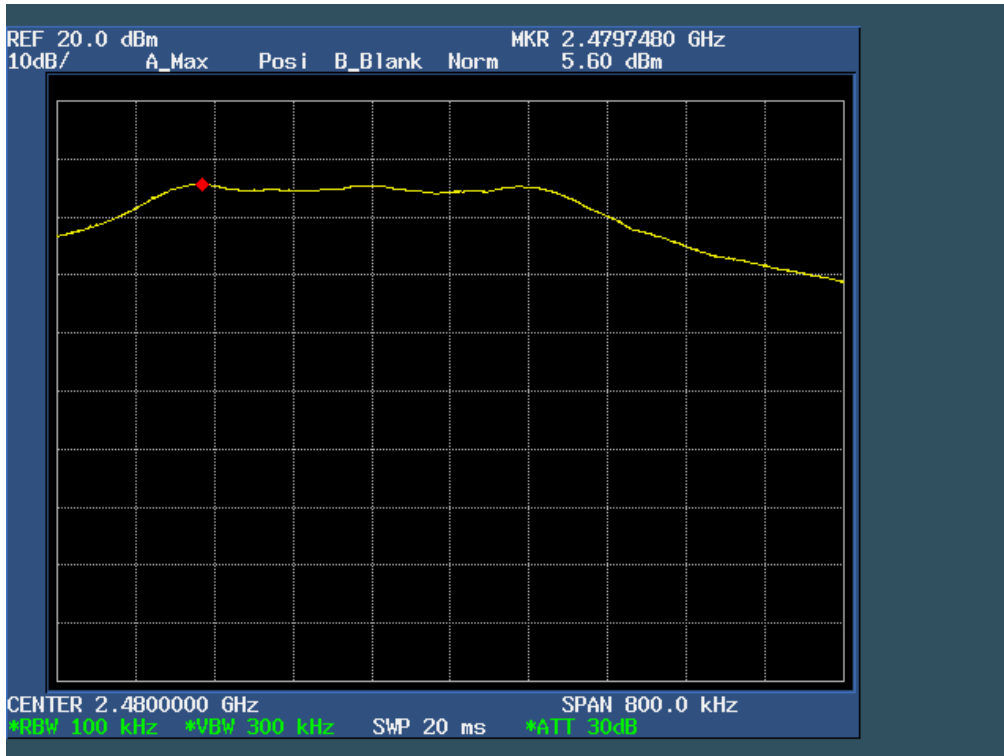

PSD 3kHz (1Mbps)
The Lowest Channel 00: 2402MHz

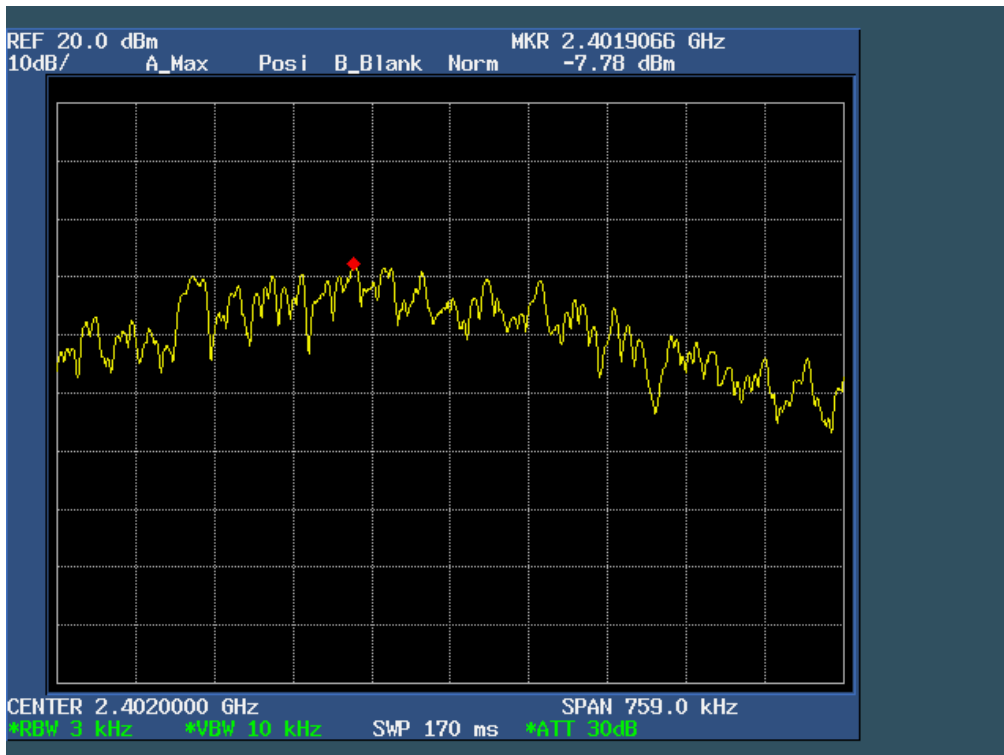

PSD 3kHz (1Mbps)
The Middle Channel 19: 2440MHz

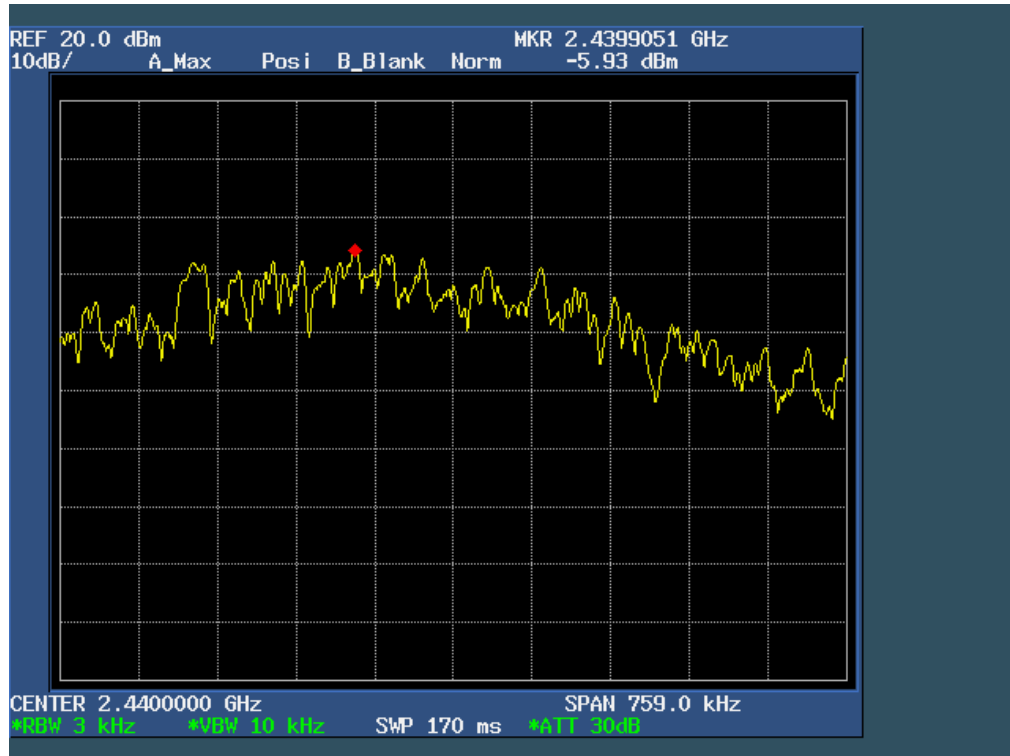

PSD 3kHz (1Mbps)
The High Channel 39: 2480MHz

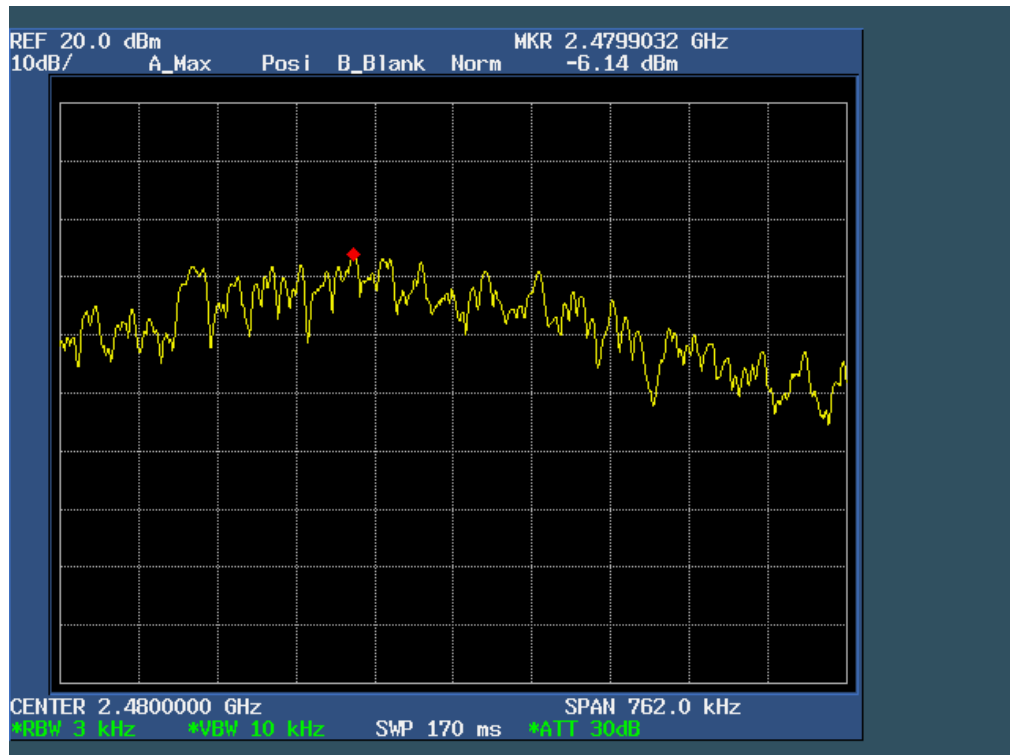

6.6 Maximum Peak Output Power

6.6.1 Applied procedures / Limit

15.247(b) (3) For systems using digital modulation in the 902-928 MHz, 2400-2483.5 MHz, and 5725-5850 MHz bands: 1 Watt. As an alternative to a peak power measurement, compliance with the one Watt limit can be based on a measurement of the maximum conducted output power. Maximum Conducted Output Power is defined as the total transmit power delivered to all antennas and antenna elements averaged across all symbols in the signaling alphabet when the transmitter is operating at its maximum power control level. Power must be summed across all antennas and antenna elements. The average must not include any time intervals during which the transmitter is off or is transmitting at a reduced power level. If multiple modes of operation are possible (e.g., alternative modulation methods), the maximum conducted output power is the highest total transmit power occurring in any mode.

6.6.2 Test procedure

- a. The testing follows FCC KDB publication No. 558074 D01 DTS Meas. Guidance v03r02
- b. The EUT was directly connected to the spectrum analyzer and antenna output port as show in the block diagram below.
- c. Spectrum Setting: $RBW \geq \text{Bandwidth}$, $VBW \geq 3 \times RBW$, Sweep time = Auto, $\text{Span} \geq 3 \times RBW$,

6.6.3 Deviation from standard

No deviation.

6.6.4 Test setup



6.6.5 Test results

EUT:	Reverie 4.1 Bluetooth Speaker	Model Name :	AM-BT-S01
Temperature:	26 °C	Relative Humidity:	60%
Pressure:	1010 hPa	Test Voltage :	DC 16.0V from Adapter , AC 120V/60Hz for Adapter
Test Mode :	TX (1Mbps)		
Note:1. All the data rates have be tested and the worst-case as the table below.			

Test Mode	Frequency	Reading Power (dBm)	Cable Loss (dB)	Peak Output Power (dBm)	Limit (dBm)	Result
Data rate 1Mbps	2402 MHz	3.84	0.5	4.34	30	Pass
	2440 MHz	5.58	0.5	6.08	30	Pass
	2480 MHz	5.31	0.5	5.81	30	Pass

(1Mbps)
The Lowest Channel 00: 2402MHz

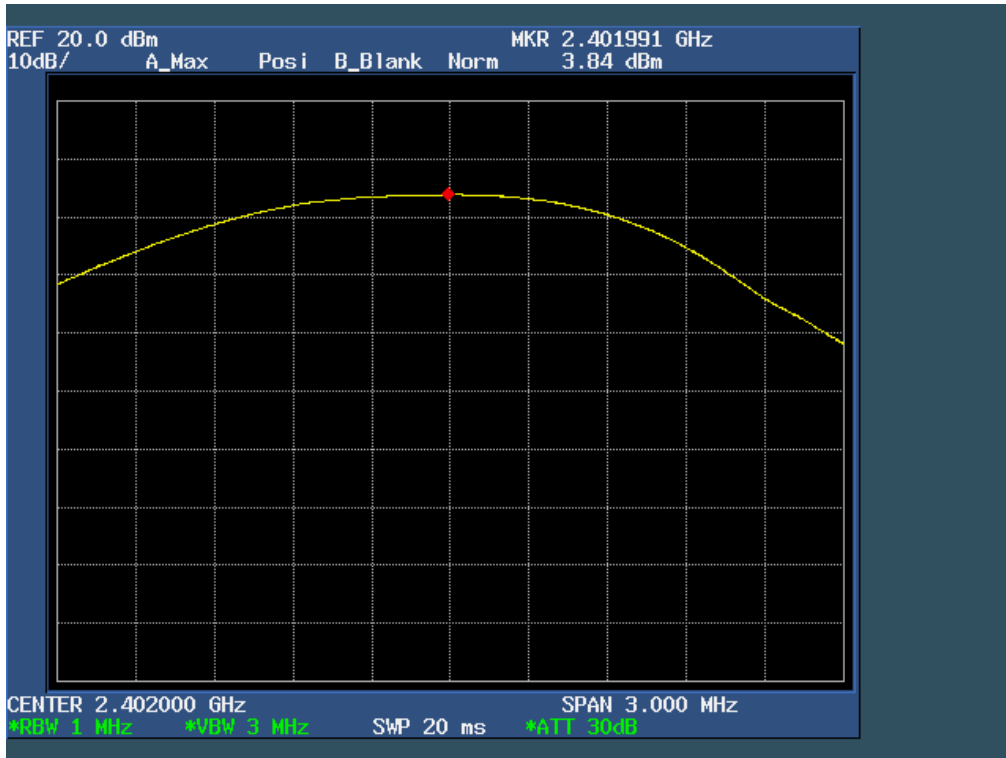

(1Mbps)
The Middle Channel 19: 2440MHz

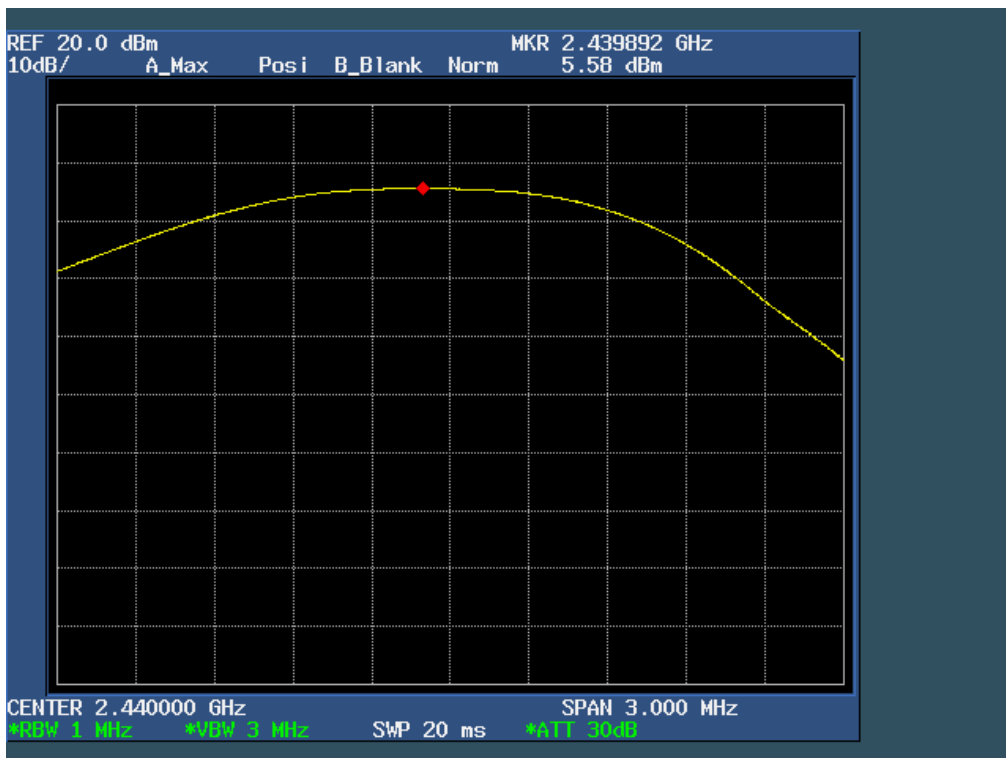

(1Mbps)
The High Channel 39: 2480MHz

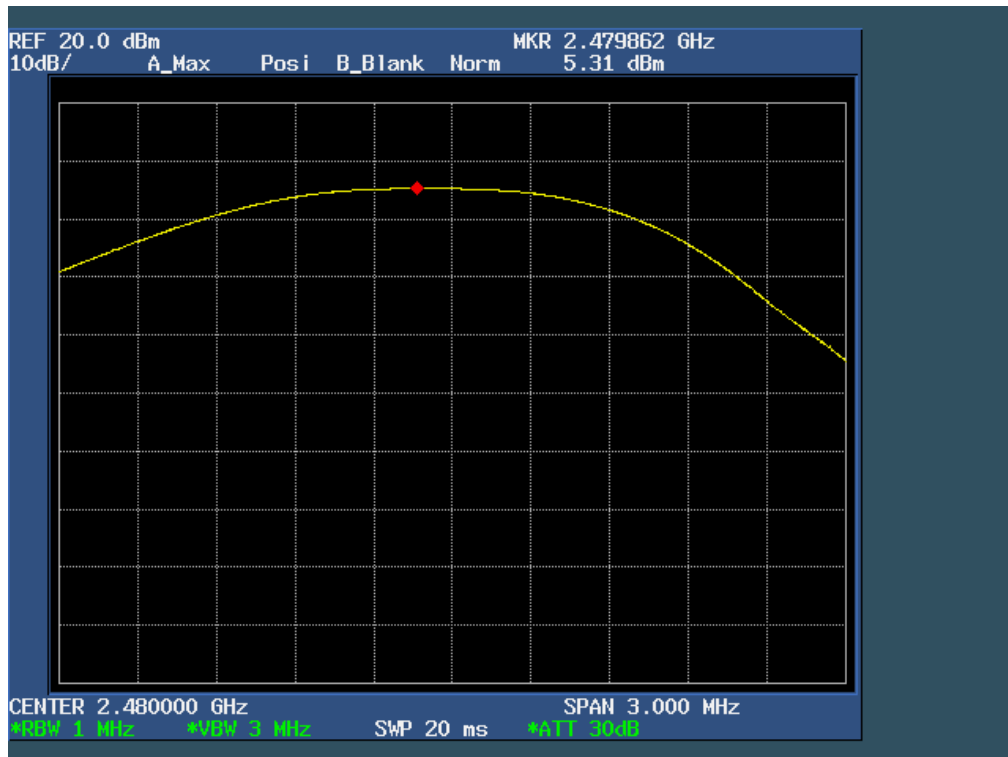

6.7 Band edge

6.7.1 Applied procedures / Limit

15.247(d) In any 100 kHz bandwidth outside the frequency band in which the spread spectrum or digitally modulated intentional radiator is operating, the radio frequency power that is produced by the intentional radiator shall be at least 20 dB below that in the 100 kHz bandwidth within the band that contains the highest level of the desired power, based on either an RF conducted or a radiated measurement, provided the transmitter demonstrates compliance with the peak conducted power limits. If the transmitter complies with the conducted power limits based on the use of RMS averaging over a time interval, as permitted under paragraph (b)(3) of this section, the attenuation required under this paragraph shall be 30 dB instead of 20 dB. Attenuation below the general limits specified in Section 15.209(a) is not required. In addition, radiated emissions which fall in the restricted bands, as defined in Section 15.205(a), must also comply with the radiated emission limits specified in Section 15.209(a) (see Section 15.205(c)).

6.7.2 Test procedure

- a. The testing follows FCC KDB publication No. 558074 D01 DTS Meas. Guidance v03r02
- b. The EUT was directly connected to the spectrum analyzer and antenna output port as show in the block diagram below.
- c. Spectrum Setting: RBW=100kHz, VBW \geq 300kHz, Sweep time=Auto, Detector Function=Peak.

6.7.3 Deviation from standard

No deviation.

6.7.4 Test setup



6.7.5 Test results

(1Mbps) The Lowest Channel 00: 2402MHz

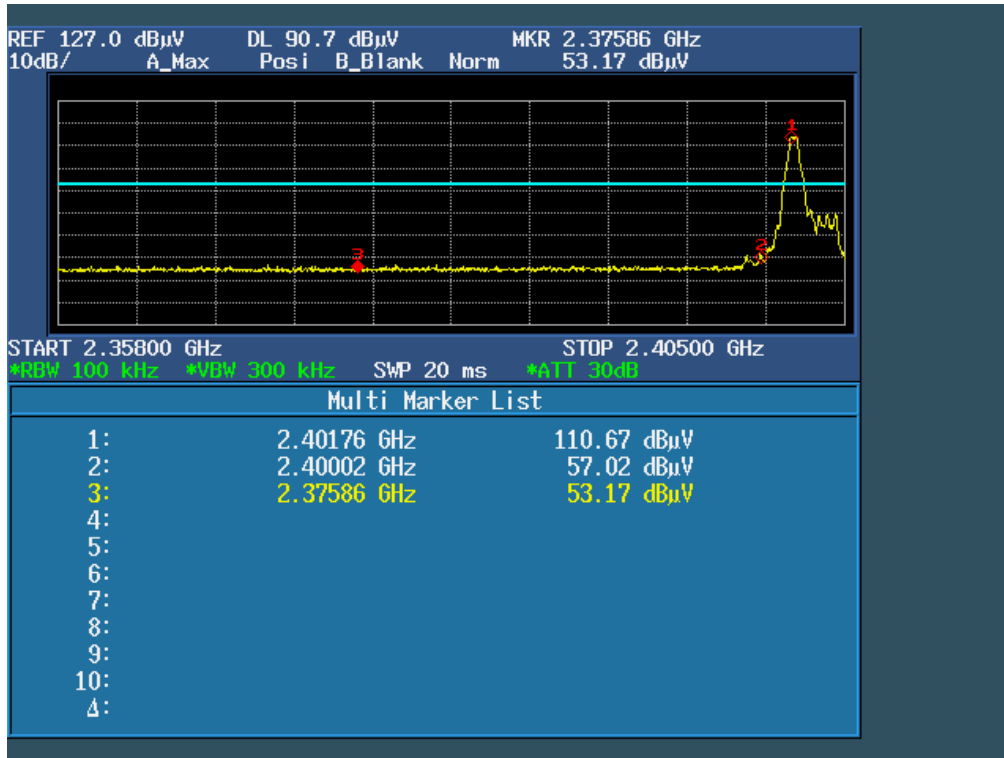

(1Mbps) The High Channel 39: 2480MHz

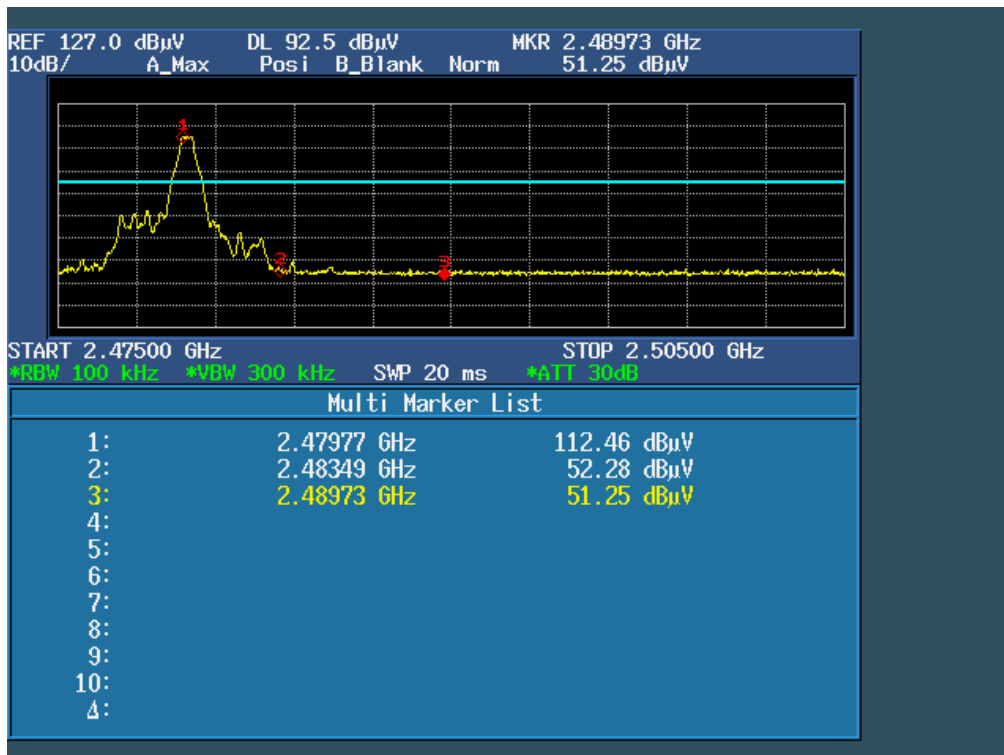

6.8 Conducted Spurious Emissions

6.8.1 Applied procedures / Limit

15.247(d) In any 100 kHz bandwidth outside the frequency band in which the spread spectrum or digitally modulated intentional radiator is operating, the radio frequency power that is produced by the intentional radiator shall be at least 20 dB below that in the 100 kHz bandwidth within the band that contains the highest level of the desired power, based on either an RF conducted or a radiated measurement, provided the transmitter demonstrates compliance with the peak conducted power limits. If the transmitter complies with the conducted power limits based on the use of RMS averaging over a time interval, as permitted under paragraph (b)(3) of this section, the attenuation required under this paragraph shall be 30 dB instead of 20 dB. Attenuation below the general limits specified in Section 15.209(a) is not required. In addition, radiated emissions which fall in the restricted bands, as defined in Section 15.205(a), must also comply with the radiated emission limits specified in Section 15.209(a) (see Section 15.205(c)).

6.8.2 Test procedure

- a. The testing follows FCC KDB publication No. 558074 D01 DTS Meas. Guidance v03r02
- b. The EUT was directly connected to the spectrum analyzer and antenna output port as show in the block diagram below.
- c. Spectrum Setting: RBW=100kHz, VBW=300kHz, Sweep time=Auto, Detector Function=Peak.

6.8.3 Deviation from standard

No deviation.

6.8.4 Test setup



6.8.5 Test results

(1Mbps)

The Lowest Channel 00: 2402MHz

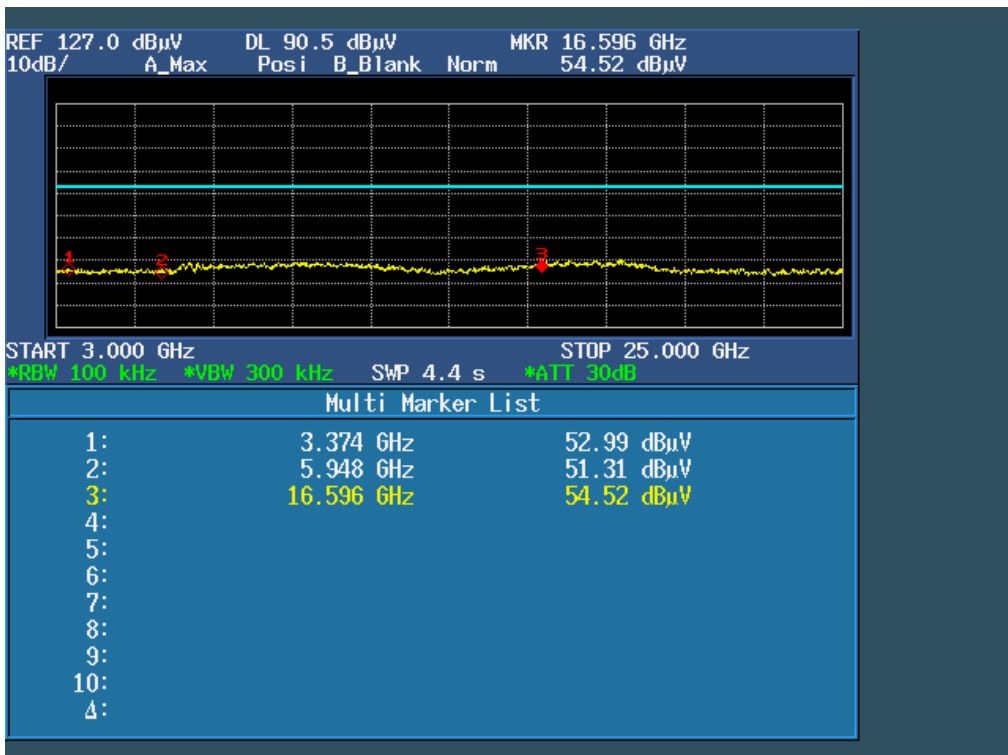
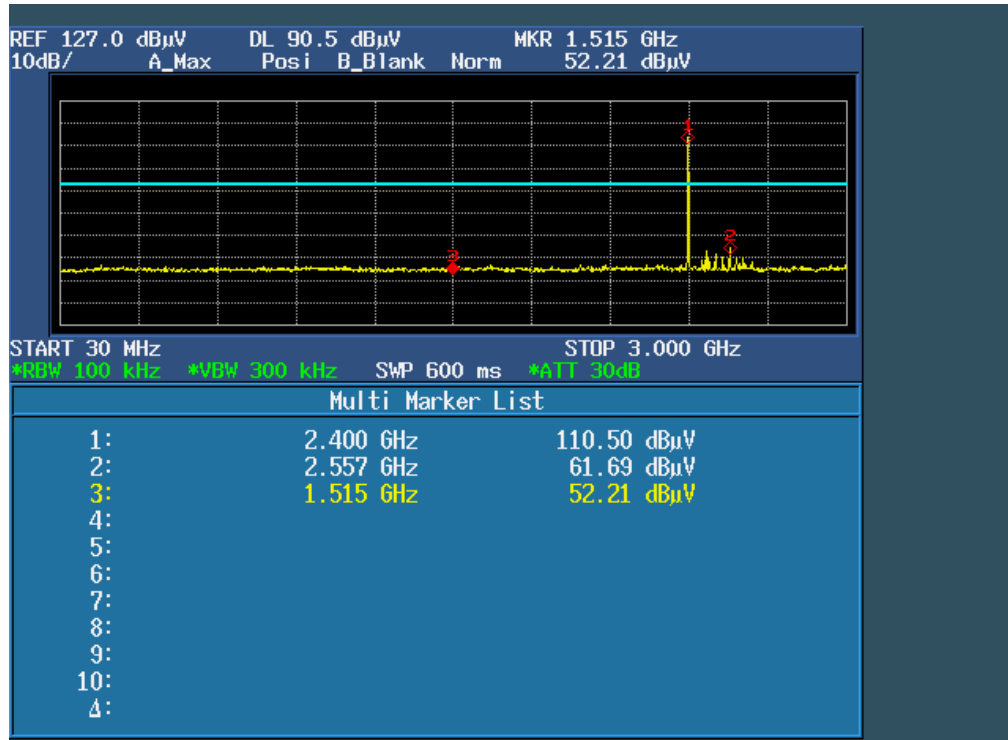

(1Mbps)
 The Middle Channel 19: 2440MHz

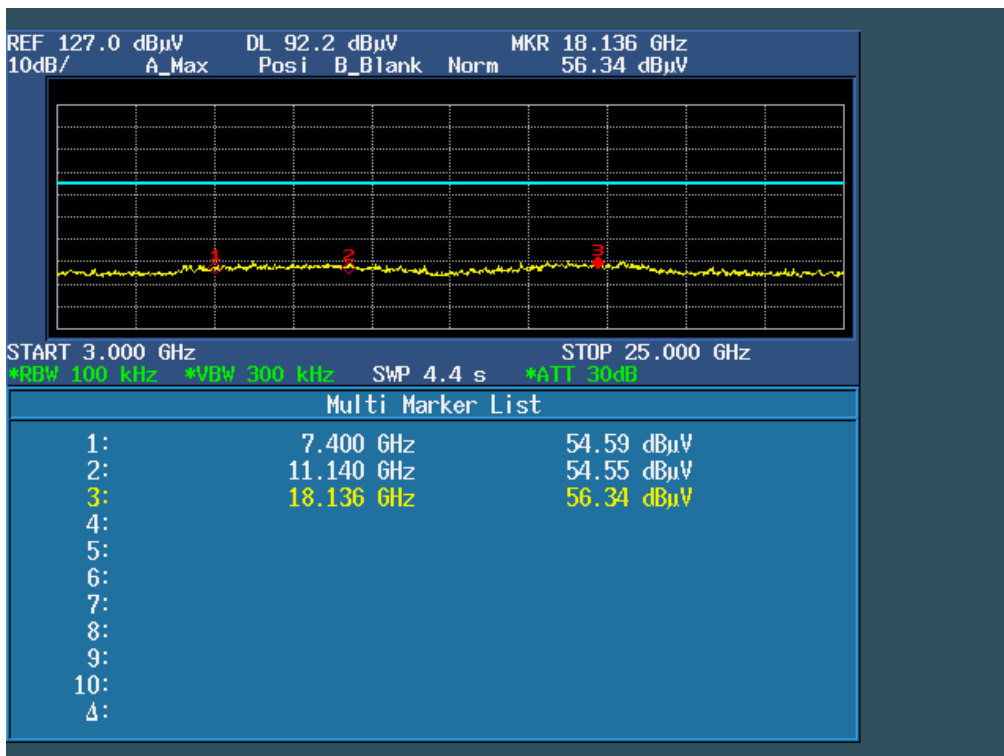

(1Mbps)
 The High Channel 39: 2480MHz

