

APPLICATION FOR CERTIFICATION
On Behalf of

RedOctane, Inc.

Wireless Drum Receiver for PS2&PS3

Model Number: PRT-0002.808

FCC ID: VFIPRT0002808

Prepared for : RedOctane, Inc.
444 Castro Street, Suite#140, Mountain View, CA
94041,USA

Prepared By : Audix Technology (Shenzhen) Co., Ltd.
No. 6, Ke Feng Rd., 52 Block,
Shenzhen Science & Industrial Park,
Nantou, Shenzhen, Guangdong, China

Tel: (0755) 26639496

Report Number : ACS-F09170
Date of Test : Aug.18~21, 2009
Date of Report : Aug.26, 2009

TABLE OF CONTENTS

Description	Page
1. SUMMARY OF STANDARDS AND RESULTS	1-1
1.1. Description of Standards and Results.....	1-1
2. GENERAL INFORMATION.....	2-1
2.1. Description of Device (EUT).....	2-1
2.2. Tested Supporting System Details	2-2
2.3. Test Facility.....	2-3
2.4. Test Uncertainty (95% confidence levels, k=2).....	2-3
3. POWER LINE CONDUCTED EMISSION TEST.....	3-1
3.1. Test Equipments.....	3-1
3.2. Block Diagram of Test Setup.....	3-1
3.3. Power Line Conducted Emission Test Limits	3-1
3.4. Configuration of EUT on Test	3-2
3.5. Operating Condition of EUT.....	3-2
3.6. Test Procedure.....	3-2
3.7. Power Line Conducted Emission Test Results.....	3-2
4. RADIATED EMISSION TEST.....	4-1
4.1. Test Equipment	4-1
4.2. Block Diagram of Test Setup.....	4-1
4.3. Radiated Emission Limit Standard: FCC 15.209 and 15.249	4-2
4.4. EUT Configuration on Test.....	4-3
4.5. Operating Condition of EUT.....	4-3
4.6. Test Procedure.....	4-3
4.7. Radiated Emission Test Results	4-3
4.8. Duty factor	4-18
5. 20DB BANDWIDTH TEST.....	5-1
5.1. Test Equipment	5-1
5.2. Limit.....	5-1
5.3. Test Results	5-1
6. BAND EDGE COMPLIANCE TEST.....	6-1
6.1. Test Equipment	6-1
6.2. Limit.....	6-1
6.3. Test Produce	6-1
6.4. Test Results	6-1
7. DEVIATION TO TEST SPECIFICATIONS	7-1
8. PHOTOGRAPH OF TEST.....	8-1
8.1. Photos of Power Line Conducted Emission Test	8-1
8.2. Photos of Radiated Emission Test (In Anechoic Chamber).....	8-2
9. PHOTOGRAPH OF EUT.....	9-1

TEST REPORT CERTIFICATION

Applicant : RedOctane, Inc.
 Manufacturer : Berway Technology Ltd.
 EUT Description : Wireless Drum Receiver for PS2&PS3
 FCC ID : VFIPRT0002808
 (A)MODEL NO. : PRT-0002.808
 (B)SERIAL NO. : N/A
 (C)POWER SUPPLY : DC 5V
 (D)TEST VOLTAGE : DC 5V From PS3 Input AC 120V/60Hz

Test Procedure Used:

FCC Rules and Regulations Part 15 Subpart C 2008

The device described above is tested by Audix Technology (Shenzhen) Co., Ltd. to determine the maximum emission levels emanating from the device. The maximum emission levels are compared to the FCC Part 15 Subpart C limits for radiated and conducted emissions.

The test results are contained in this test report and Audix Technology (Shenzhen) Co., Ltd. is assumed full responsibility for the accuracy and completeness of tests. Also, this report shows that EUT is technically compliant with FCC requirements.

This report applies to above tested sample only. This report shall not be reproduced in part without written approval of Audix Technology (Shenzhen) Co., Ltd.

Date of Test : Aug.18~ 21, 2009

Prepared by :

Edie Huang
 Edie Huang / Assistant

Reviewer :

Jamy Yu
 Jamy Yu / Senior Engineer

Approved & Authorized Signer :



Ken Lu
 Ken Lu / Manager

1. SUMMARY OF STANDARDS AND RESULTS

1.1. Description of Standards and Results

The EUT have been tested according to the applicable standards as referenced below.

EMISSION		
Description of Test Item	Standard	Results
Power Line Conducted Emission Test	FCC Part 15C: 15.207 ANSI C63.4-2003	PASS
Radiated Emission Test	FCC Part 15C: 15.209 FCC Part 15C: 15.249 ANSI C63.4-2003	PASS
Band Edge Compliance Test	FCC Part 15: 15.249	PASS
20dB Bandwidth Test	FCC Part 15: 15.215	PASS
N/A is an abbreviation for Not Applicable.		

2. GENERAL INFORMATION

2.1. Description of Device (EUT)

Product name : Wireless Drum Receiver for PS2&PS3

Model Number : PRT-0002.808

FCC ID : VFIPRT0002808

Operation frequency : 2410MHz-----2469.2MHz

Modulation Technology : MSK

Maximum emission : 87.19dBuV/m@3m on 2469.2MHz

Antenna Assembly Gain : 0dBi(maximum)

Power Supply : DC 5V From PS3 Input AC 120V/60Hz
(The supply voltage was varied between 85% and 115% of the nominal rated (120V/60Hz) supply voltage. And all the emissions include fundamental emissions had no change. So only the nominal power supply test data were recorded.)

Applicant : RedOctane, Inc.
444 Castro Street, Suite#140, Mountain View, CA
94041,USA

Manufacturer : Berway Technology Ltd.
Unit1301-03, 13/F., No.88 Kwai Cheong Road, Kwai Chung,
N.T., H.K.

Date of Test : Aug.18~21, 2009

Date of Receipt : Aug.01, 2009

Sample Type : Prototype production

2.2. Tested Supporting System Details

2.2.1. TV

EMC CODE : ACS-EMC-TV01T
M/N : 1419A
Manufacturer : TCL
Power cord : Unshielded, Undetachabled, 1.8m

2.2.2. PS3

S/N : 02-27430423-6785596-CECHC04

2.2.3. PS3 Wireless Guitar

M/N : P61247
Manufacturer : RedOctane, Inc.

2.3. Test Facility

Site Description	
Name of Firm	: Audix Technology (Shenzhen) Co., Ltd. No. 6, Ke Feng Rd., 52 Block, Shenzhen Science & Industrial Park, Nantou, Shenzhen, Guangdong, China
3m Anechoic Chamber	: Mar. 31, 2009 File on Federal Communication Commission Registration Number: 90454
3m & 10m Anechoic Chamber	: Jan. 31, 2007 File on Federal Communication Commission Registration Number: 794232
EMC Lab.	: Accredited by DATech, German Registration Number: DAT-P-091/99-01 Feb. 02, 2009
	Accredited by NVLAP, USA NVLAP Code: 200372-0 Apr.01, 2009

2.4. Test Uncertainty (95% confidence levels, k=2)

Test Item	Uncertainty
Uncertainty for Conduction emission test in No. 1 Conduction	2.40dB
Uncertainty for Radiation Emission test in 3m chamber	3.78 dB (Polarize: V)
	4.20 dB (Polarize: H)
Uncertainty for Bandwidth test	1×10^{-9}
Uncertainty for DC power test	0.042 %
Uncertainty for test site temperature and humidity	0.6°C
	3%

3. POWER LINE CONDUCTED EMISSION TEST

3.1. Test Equipments

Item	Equipment	Manufacturer	Model No.	Serial No.	Last Cal.	Cal. Interval
1	Test Receiver	Rohde & Schwarz	ESHS10	838693/001	Jan.10, 09	1 Year
2	L.I.S.N.#2	Kyoritsu	KNW-407	8-1636-1	May.08, 09	1 Year
3	L.I.S.N.#3	Kyoritsu	KNW-242C	8-1920-1	May.08, 09	1 Year
4	Terminator	Hubersuhner	50Ω	No. 1	May.08, 09	1 Year
5	RF Cable	Fujikura	3D-2W	LISN Cable 1#	May.08, 09	1Year
6	Coaxial Switch	Anritsu	MP59B	M55367	May.08, 09	1 Year
7	Pulse Limiter	Rohde & Schwarz	ESH3-Z2	100341	May.08, 09	1 Year

3.2. Block Diagram of Test Setup

3.2.1. Block diagram of connection between the EUT and Supporting System

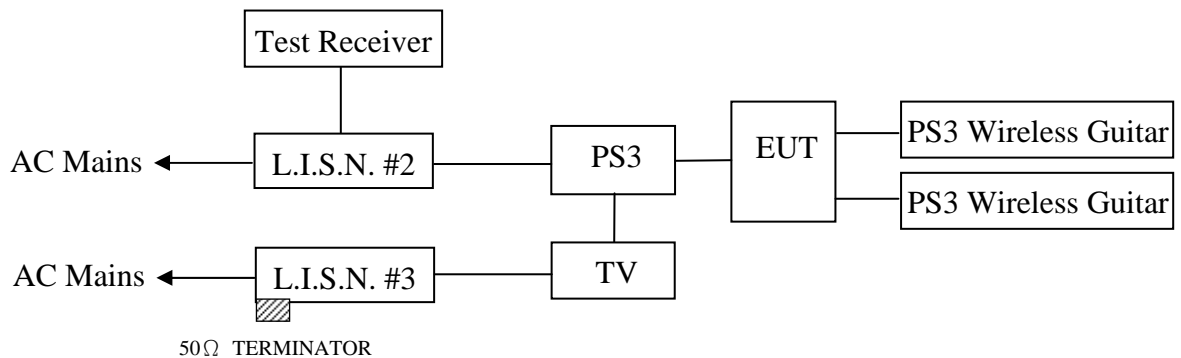

(EUT: Wireless Drum Receiver for PS2&PS3)

3.3. Power Line Conducted Emission Test Limits

Frequency	Maximum RF Line Voltage	
	Quasi-Peak Level dB(μV)	Average Level dB(μV)
150kHz ~ 500kHz	66 ~ 56*	56 ~ 46*
500kHz ~ 5MHz	56	46
5MHz ~ 30MHz	60	50

Notes: 1. * Decreasing linearly with logarithm of frequency.

2. The lower limit shall apply at the transition frequencies.

3.4. Configuration of EUT on Test

The following equipment are installed on Power Line Conducted Emission Test to meet the commission requirement and operating regulations in a manner which tends to maximize its emission characteristics in a normal application.

3.4.1. Wireless Drum Receiver for PS2&PS3 (EUT)

Model Number : PRT-0002.808
Serial Number : N/A

3.4.2. Support Equipment : As Tested Supporting System Detail, in Section 2.2

3.5. Operating Condition of EUT

3.5.1. Setup the EUT and simulator as shown as Section 3.2.

3.5.2. Turned on the power of all equipment.

3.5.3. Let the EUT worked in test modes (Tx Mode) and measured it.

3.6. Test Procedure

The EUT was placed on the ground plane. The EUT Power Via PS3 connected to the power mains through a line impedance stabilization network (L.I.S.N. 2#). This provides a 50 ohm coupling impedance for the EUT (Please refer the block diagram of the test setup and photographs). The other peripheral devices power cord connected to the power mains through a line impedance stabilization network (L.I.S.N.#3). Power on the PS3 and let it work normally, we use a test software, let EUT working in test mode, then test it. Both sides of AC line are checked to find out the maximum conducted emission. In order to find the maximum emission levels, the relative positions of equipment and all of the interface cables shall be changed according to ANSI C63.4: 2003 on Conducted Emission Test.

The bandwidth of test receiver (R & S ESHS10) is set at 10kHz.

The frequency range from 150kHz to 30MHz is checked.

The test result are reported on Section 3.7.,

3.7. Power Line Conducted Emission Test Results

PASS. (All emissions not reported below are too low against the prescribed limits.)



NO.6 Ke Feng Road,Block 52,
Shenzhen Science&Industry Park
Nantou, Shenzhen,Guang dong, China.
Tel:+86-755-26639495
Fax:+86-755-26632877
Postcode:518057

Data: 3 File: D:\DATA\2009 Report\A\Axis\ACS9QH233.EM6 (10)

Date: 2009-08-20

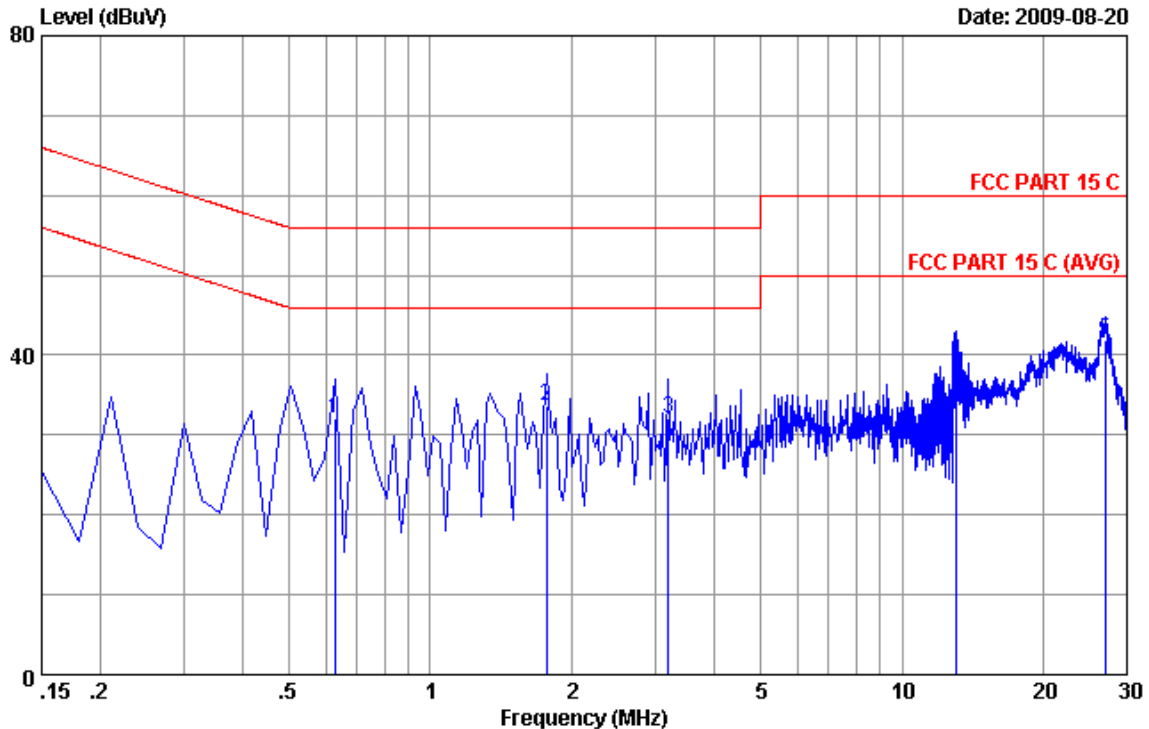

Site no :Audix No.1 Conduction Data no :3
 Dis./Ant. **: 2009 KNW407 VA
 Limit :FCC PART 15 C
 Env./Ins. :Temp:23'C Humi:54% Engineer :Power Feng
 EUT :Wireless Drum Receiver for PS2&PS3
 Power Rating :DC 5V From PS3 Iuput AC 120V/60Hz
 Test Mode :Tx Mode
 M/N:PRT-0002.808

No	Freq (MHz)	LISN Factor (dB)	Cable Loss (dB)	Reading (dBuV)	Emission Level (dBuV)	Limits (dBuV)	Margin (dB)	Remark
1	0.62760	0.36	9.89	21.77	32.02	56.00	23.98	QP
2	1.762	0.36	9.89	23.36	33.61	56.00	22.39	QP
3	3.195	0.36	9.91	21.83	32.10	56.00	23.90	QP
4	13.045	0.47	9.96	28.49	38.92	60.00	21.08	QP
5	26.955	0.69	10.04	31.15	41.88	60.00	18.12	QP

Remarks: 1.Emission Level=LISN Factor+Cable Loss(Include 10dB pulse limit)+Reading
 2.If the average limit is met when using a quasi-peak detector, the EUT shall be deemed to meet both limits and measurement with average detector is unnecessary.



NO.6 Ke Feng Road,Block 52,
Shenzhen Science&Industry Park
Nantou, Shenzhen,Guang dong, China.
Tel:+86-755-26639495
Fax:+86-755-26632877
Postcode:518057

Data: 4 File: D:\DATA\2009 Report\A\Axis\ACS9QH233.EM6 (10)

Date: 2009-08-20

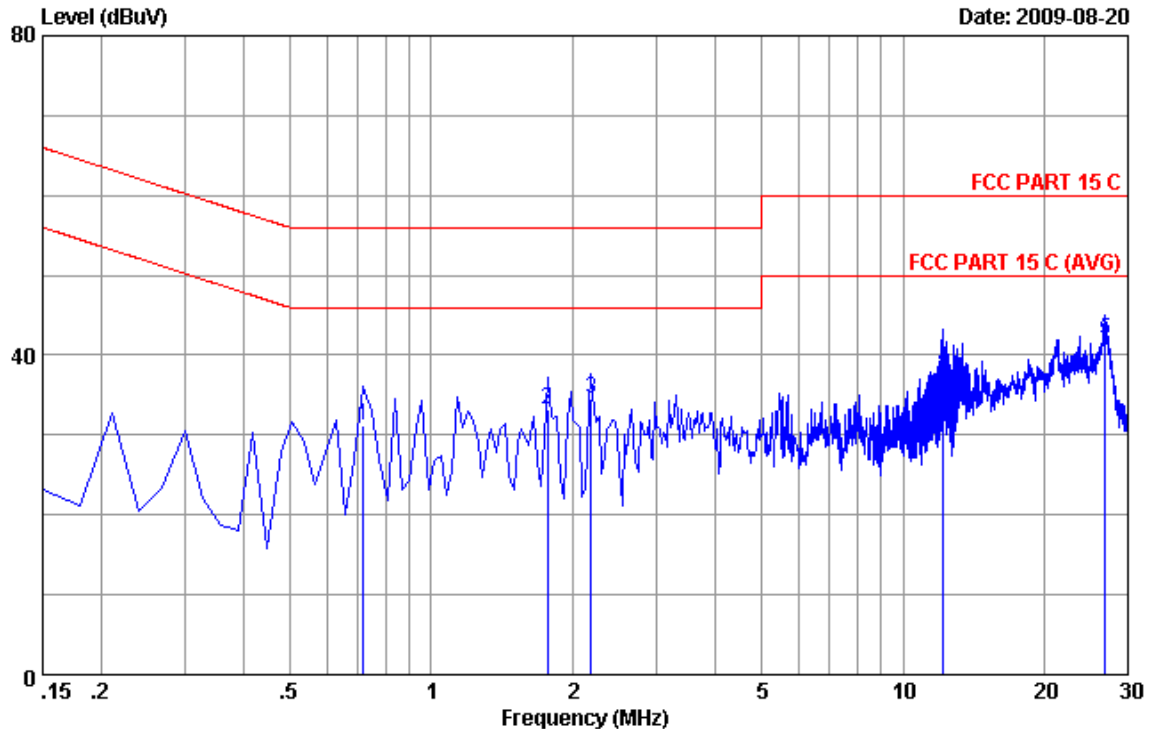

Site no :Audix No.1 Conduction Data no :4
 Dis./Ant. **: 2009 KNW407 VB
 Limit :FCC PART 15 C
 Env./Ins. :Temp:23'C Humi:54% Engineer :Power Feng
 EUT :Wireless Drum Receiver for PS2&PS3
 Power Rating :DC 5V From PS3 Iuput AC 120V/60Hz
 Test Mode :Tx Mode
 M/N:PRT-0002.808

No	Freq (MHz)	LISN Factor (dB)	Cable Loss (dB)	Reading (dBuV)	Emission Level (dBuV)	Limits (dBuV)	Margin (dB)	Remark
1	0.71715	0.35	9.89	20.92	31.16	56.00	24.84	QP
2	1.762	0.36	9.89	22.86	33.11	56.00	22.89	QP
3	2.180	0.36	9.90	24.35	34.61	56.00	21.39	QP
4	12.209	0.46	9.95	27.84	38.25	60.00	21.75	QP
5	26.896	0.61	10.04	31.27	41.92	60.00	18.08	QP

Remarks: 1.Emission Level=LISN Factor+Cable Loss(Include 10dB pulse limit)+Reading
 2.If the average limit is met when using a quasi-peak detector, the EUT shall be deemed to meet both limits and measurement with average detector is unnecessary.

4. RADIATED EMISSION TEST

4.1. Test Equipment

Frequency rang: 30~1000MHz

Item	Equipment	Manufacturer	Model No.	Serial No.	Last Cal.	Cal. Interval
1.	3#Chamber	AUDIX	N/A	N/A	Dec.05,08	1 Year
2.	EMI Spectrum	Agilent	E4407B	MY41440292	May.08, 09	1 Year
3.	Test Receiver	Rohde & Schwarz	ESVS10	834468/011	May.08, 09	1 Year
4.	Amplifier	HP	8447D	2648A04738	May.08, 09	1 Year
5.	Bilog Antenna	Schaffner	CBL6111C	2598	Nov.10, 08	1 Year
6.	RF Cable	MIYAZAKI	8D-FB	3# Chamber No.1	May.08, 09	1 Year
7.	Coaxial Switch	Anritsu	MP59B	M73989	May.08, 09	1 Year

Frequency rang: above 1000MHz

Item	Equipment	Manufacturer	Model No.	Serial No.	Last Cal.	Cal. Interval
1.	Spectrum Analyzer	Agilent	E4446A	US44300459	May.08, 09	1 Year
2.	Horn Antenna	EMCO	3115	9607-4877	May.27, 08	1.5 Year
3	Amplifier	Agilent	8449B	3008A02495	Nov.24,08	1 Year
4	RF Cable	Hubersuhner	SUCOFLEX102	28620/2	May.08, 09	1 Year
5	RF Cable	Hubersuhner	SUCOFLEX102	271471/4	May.08, 09	1 Year
6	RF Cable	Hubersuhner	SUCOFLEX102	29086/2	May.08, 09	1 Year

4.2. Block Diagram of Test Setup

4.2.1. Block Diagram of connection between EUT and simulators

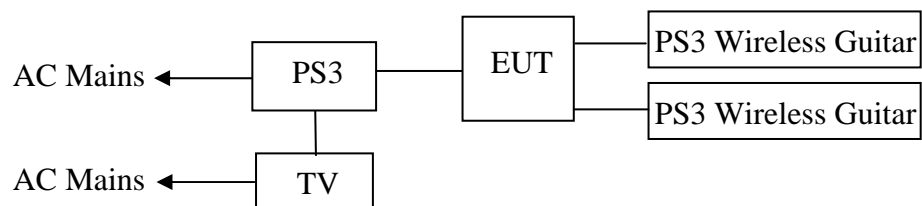

(EUT: Wireless Drum Receiver for PS2&PS3)

4.2.2. Anechoic Chamber Setup Diagram

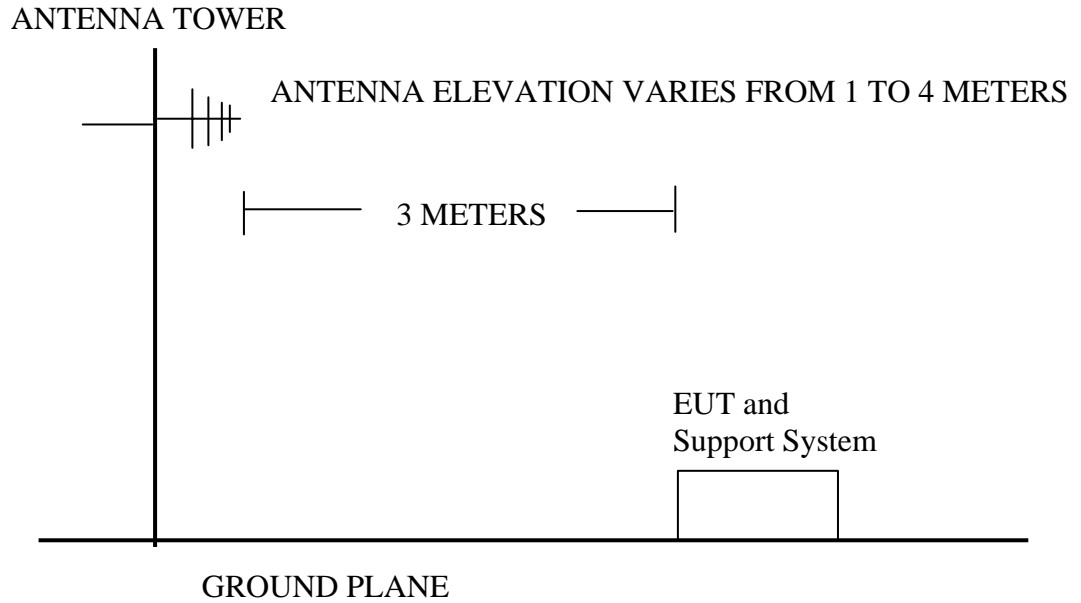

4.3. Radiated Emission Limit Standard: FCC 15.209 and 15.249

FREQUENCY MHz	DISTANCE Meters	FIELD STRENGTHS LIMIT	
		$\mu\text{V}/\text{m}$	$\text{dB}(\mu\text{V})/\text{m}$
30 ~ 88	3	100	40.0
88 ~ 216	3	150	43.5
216 ~ 960	3	200	46.0
960 ~ 1000	3	500	54.0
Above 1000MHz	3	74.0 $\text{dB}(\mu\text{V})/\text{m}$ (Peak) 54.0 $\text{dB}(\mu\text{V})/\text{m}$ (Average)	
Field Strength of Fundamental emission for 2.4GHz-2.4835GHz	3	94.0 $\text{dB}(\mu\text{V})/\text{m}$ (Average) 114.0 $\text{dB}(\mu\text{V})/\text{m}$ (Peak)	
Field Strength of Harmonics	3	74.0 $\text{dB}(\mu\text{V})/\text{m}$ (Peak) 54.0 $\text{dB}(\mu\text{V})/\text{m}$ (Average)	

- Remark :
- (1) Emission level $\text{dB}\mu\text{V} = 20 \log$ Emission level $\mu\text{V}/\text{m}$
 - (2) The smaller limit shall apply at the cross point between two frequency bands.
 - (3) Distance is the distance in meters between the measuring instrument, antenna and the closest point of any part of the device or system.
 - (4) The emission limits shown in the above table are based on measurements employing a CISPR quasi-peak detector except for the frequency bands 9-90 kHz, 110-490 kHz and above 1000 MHz. Radiated emission limits in these three bands are based on measurements employing an average detector.

4.4. EUT Configuration on Test

The following equipment are installed on Radiated Emission Test to meet the commission requirements and operating regulations in a manner which tends to maximize its emission characteristics in normal application.

4.4.1. Wireless Drum Receiver for PS2&PS3 (EUT)

Model Number : PRT-0002.808

Serial Number : N/A

4.4.2. Support Equipment: As Tested Supporting System Detail, in Section 2.2

4.5. Operating Condition of EUT

4.5.1. Setup the EUT as shown in Section 4.2..

4.5.2. Turned on the power of all equipment.

4.5.3. Let the EUT worked in test mode (Tx Mode) and tested it.

4.6. Test Procedure

The EUT and its simulators are placed on the ground. The turn table can rotate 360 degrees to determine the position of the maximum emission level. The EUT is set 3 meters away from the receiving antenna, which is mounted on a antenna tower. The antenna can be moved up and down between 1 meter and 4 meters to find out the maximum emission level. Broadband antenna (calibrated bilog antenna) is used as receiving antenna. Both horizontal and vertical polarization of the antenna is set on Test. In order to find the maximum emission levels, all of the interface cables must be manipulated according to ANSI C63.4-2003 on radiated emission Test.

The bandwidth of the EMI test receiver (R&S ESVS10) is set at 120kHz for frequency range from 30MHz to 1000 MHz.

The bandwidth of the Spectrum's VBW is set at 1MHz and RBW is set at 1MHz for peak emissions measurement above 1GHz

This product is pulse modulated, pulse desensitization correction factor (PDCF) was used to determine the Average level.

The frequency range from 30MHz to 10th harmonic (25GHz) are checked. and no any emissions were found from 18GHz to 25 GHz, So the radiated emissions from 18GHz to 25GHz were not record.

4.7. Radiated Emission Test Results

PASS.

All the emissions from 30MHz to 25GHz were comply with the 15.249 and 15.209 limit.

Test Frequency: 30MHz-1000MHz



No.6,Ke Feng Road,Block 52,
Shenzhen Science&Industry Park
Nantou Shenzhen,Guangdong,China
Tel:+86-755-26639495
Fax:+86-755-26632877
Postcode:518057

Data: 8

File: D:\2009 Report Data\AXIS\ACS9QH233.EM6 (25)

Date: 2009-08-18

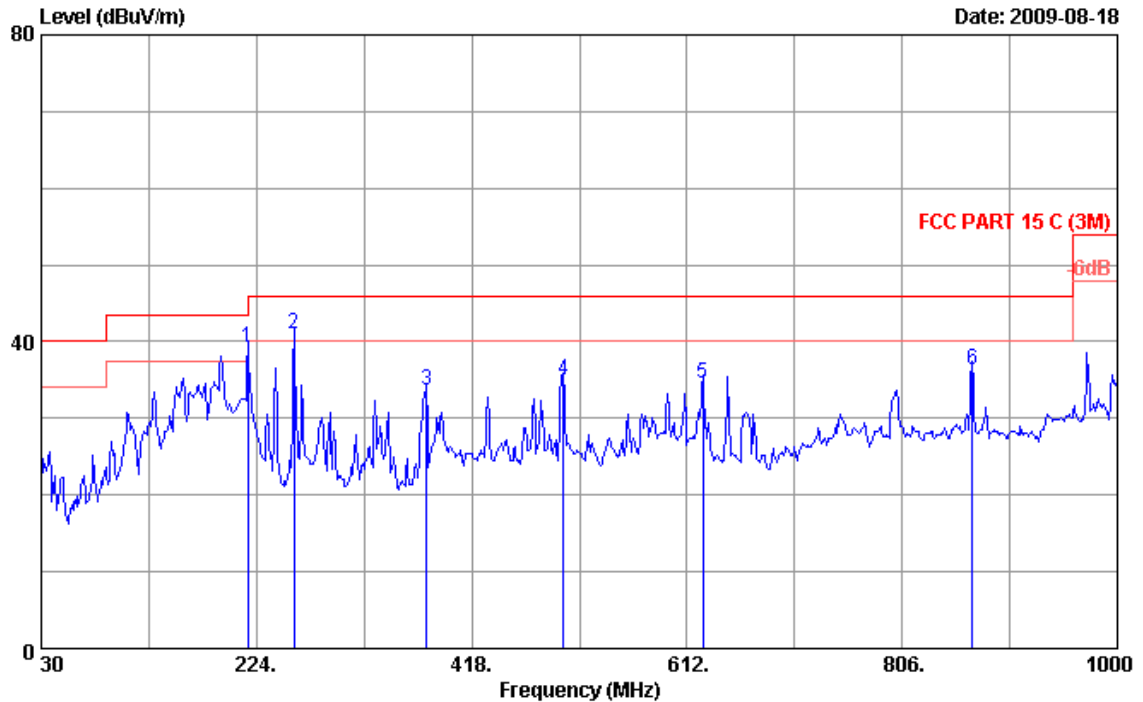

Site no. : 3m Chamber Data no. : 8
 Dis. / Ant. : 3m CBL6111C Ant. pol. : HORIZONTAL
 Limit : FCC PART 15 C (3M)
 Env. / Ins. : 24°C/56% Engineer : Cary
 EUT : Wireless Drum Receiver for PS2&PS3
 Power Rating : DC 5V From PS3 Input AC 120V/60Hz
 Test Mode : Tx mode
 M/N:PRT-0002.808

No.	Freq. (MHz)	Ant. Factor (dB/m)	Cable Loss (dB)	Reading (dBuV)	Emission Level (dBuV/m)	Limits (dBuV/m)	Margin (dB)	Remark
1	216.240	9.98	1.41	27.78	39.17	46.00	6.83	QP
2	257.950	13.51	1.65	25.74	40.90	46.00	5.10	QP
3	377.260	15.57	1.88	16.12	33.57	46.00	12.43	QP
4	500.450	18.04	2.25	14.68	34.97	46.00	11.03	QP
5	626.550	19.92	2.57	12.08	34.57	46.00	11.43	QP
6	869.050	22.57	3.14	10.69	36.40	46.00	9.60	QP

Remarks: 1. Emission Level= Antenna Factor + Cable Loss + Reading.
 2. The emission levels that are 20dB below the official limit are not reported.



No.6,Ke Feng Road,Block 52,
Shenzhen Science&Industry Park
Nantou Shenzhen,Guangdong,China
Tel:+86-755-26639495
Fax:+86-755-26632877
Postcode:518057

Data: 7 File: D:\2009 Report Data\AXIS\ACS9QH233.EM6 (25)

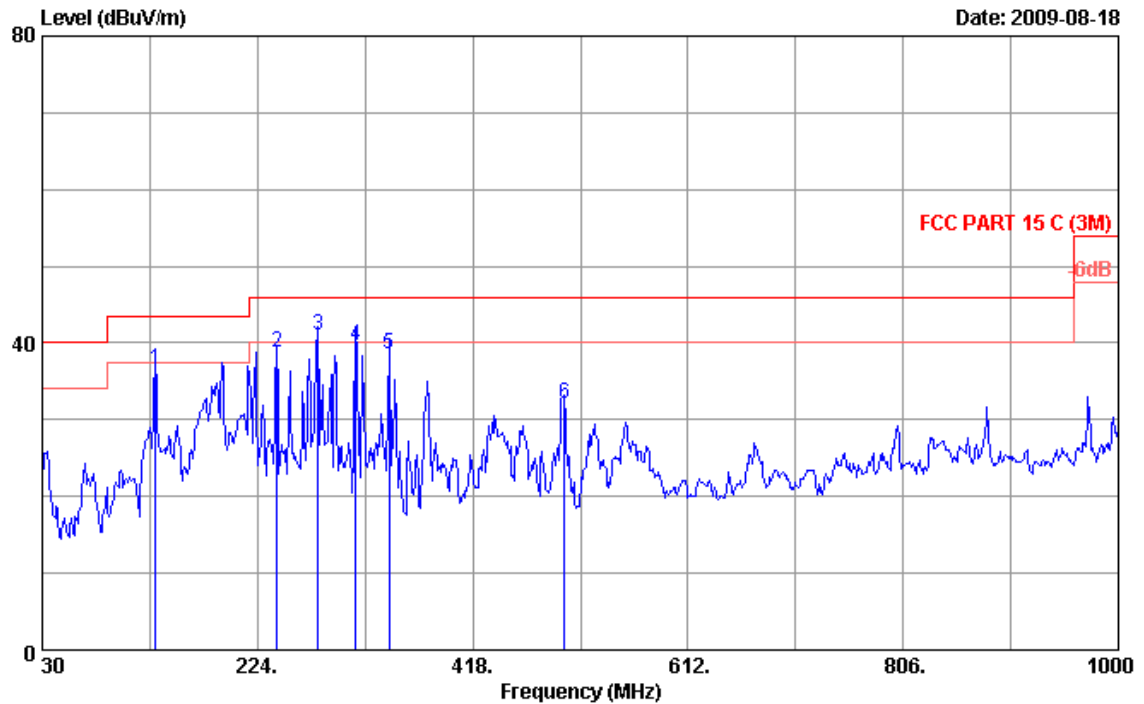

Site no. : 3m Chamber Data no. : 7
 Dis. / Ant. : 3m CBL6111C Ant. pol. : VERTICAL
 Limit : FCC PART 15 C (3M)
 Env. / Ins. : 24°C/56% Engineer : Cary
 EUT : Wireless Drum Receiver for PS2&PS3
 Power Rating : DC 5V From PS3 Input AC 120V/60Hz
 Test Mode : Tx mode
 M/N:PRT-0002.808

No.	Freq. (MHz)	Ant. Factor (dB/m)	Cable Loss (dB)	Reading (dBuV)	Emission Level (dBuV/m)	Limits (dBuV/m)	Margin (dB)	Remark
1	131.850	12.07	1.02	23.39	36.48	43.50	7.02	QP
2	241.460	11.80	1.58	25.36	38.74	46.00	7.26	QP
3	278.320	13.15	1.69	26.17	41.01	46.00	4.99	QP
4	312.270	13.77	1.75	24.07	39.59	46.00	6.41	QP
5	342.340	14.78	1.81	21.97	38.56	46.00	7.44	QP
6	500.450	18.04	2.25	11.91	32.20	46.00	13.80	QP

Remarks: 1. Emission Level= Antenna Factor + Cable Loss + Reading.
 2. The emission levels that are 20dB below the official limit are not reported.

Test Frequency: 1GHz-18GHz



No.6 Ke Feng Road,Block 52,
ShenZhen Science & Industry Park
Noutou,ShenZhen,GuangDong,China
Tel:+86-755-26639495-7
Fax:+86-755-26632877
Postcode:518057

Data: 1 File: E:\2009 report data\A\axis\ACS9QH233R.EM6 (24)

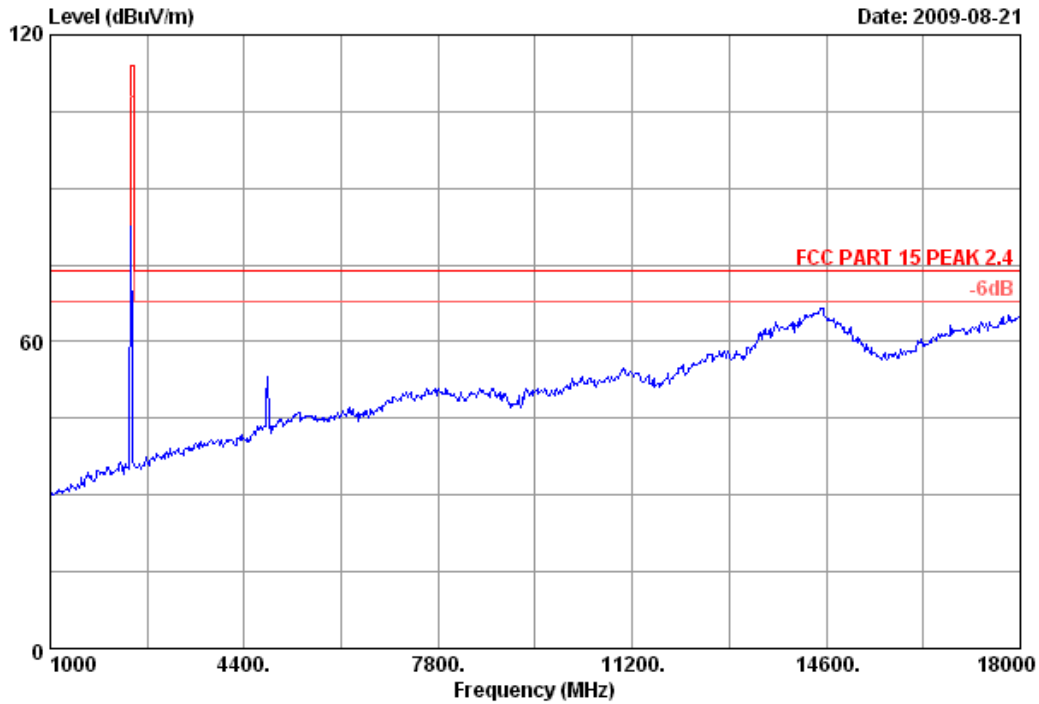

Site no.	: 3m Chamber	Data no.	: 1
Dis. / Ant.	: 3m 3115(0905)	Ant. pol.	: HORIZONTAL
Limit	: FCC PART 15 PEAK 2.4		
Env. / Ins.	: 25°C/60%	Engineer	: Power Feng
EUT	: Wireless Drum Receiver for PS2&PS3		
Power	: DC 5V from PS3 input AC120V/60Hz		
Test mode	: Tx 2410MHz		
Model/no.	: PRT-0002.808		



No.6 Ke Feng Road,Block 52,
ShenZhen Science & Industry Park
Noutou, ShenZhen, Guangdong, China
Tel:+86-755-26639495-7
Fax:+86-755-26632877
Postcode:518057

Data: 2 File: E:\2009 report data\A\axis\ACS9QH233RLEM6 (24)

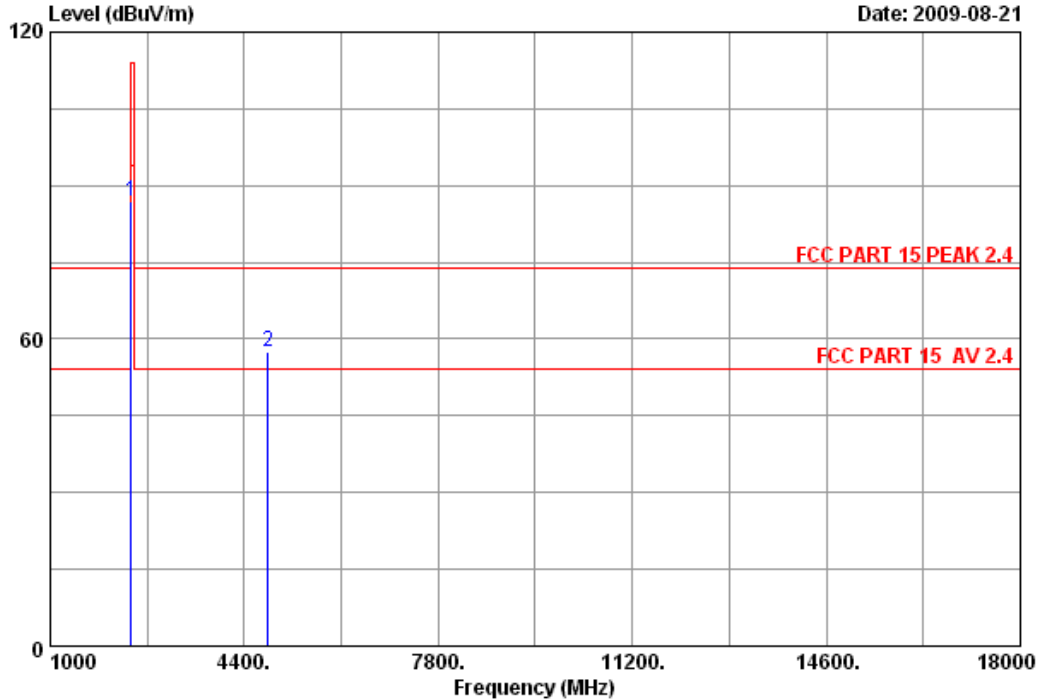

Site no. : 3m Chamber Data no. : 2
 Dis. / Ant. : 3m 3115(0905) Ant. pol. : HORIZONTAL
 Limit : FCC PART 15 PEAK 2.4
 Env. / Ins. : 25°C/60% Engineer : Power Feng
 EUT : Wireless Drum Receiver for PS2&PS3
 Power : DC 5V from PS3 input AC120V/60Hz
 Test mode : Tx 2410MHz
 Model/no. : PRT-0002.808

	Ant. Freq. (MHz)	Factor (dB/m)	Cable loss (dB)	Amp. Factor (dB)	Reading (dbuv)	Emission Level (dBUV/m)	Limits (dBUV/m)	Margin (dB)	Remark
1	2410.000	28.48	7.66	35.95	86.64	86.83	114.00	27.17	Peak
2	4820.000	34.47	10.80	35.25	47.33	57.35	74.00	16.65	Peak

- Remarks:
- Emission Level= Antenna Factor + Cable Loss -Amp Factor + Reading.
 - The emission levels that are 20dB below the official limit are not reported.

Average emissions Level

Freq (MHz)	Ant. Plo.	Peak Level (dBUV/m)	PDCF (dB)	AV Level (dBUV/m)	AV Limit (dBUV/m)	Margin (dB)
4820.0	H	57.35	24.73	32.62	54	21.38

Note: AV Level= Peak Level – PDCF



No.6 Ke Feng Road,Block 52,
 ShenZhen Science & Industry Park
 Noutou, ShenZhen, Guangdong, China
 Tel:+86-755-26639495-7
 Fax:+86-755-26632877
 Postcode:518057

Data: 3 File: E:\2009 report data\A\axis\ACS9QH233RLEM6 (24)

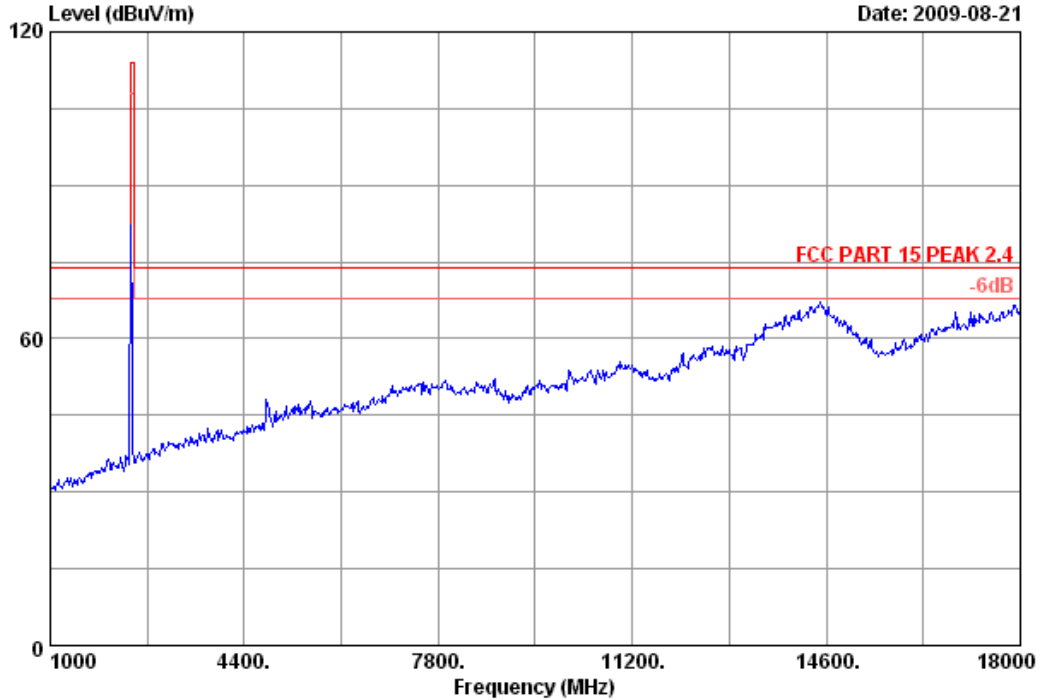

Site no.	: 3m Chamber	Data no.	: 3
Dis. / Ant.	: 3m 3115(0905)	Ant. pol.	: VERTICAL
Limit	: FCC PART 15 PEAK 2.4		
Env. / Ins.	: 25°C/60%	Engineer	: Power Feng
EUT	: Wireless Drum Receiver for PS2&PS3		
Power	: DC 5V from PS3 input AC120V/60Hz		
Test mode	: Tx 2410MHz		
Model/no.	: PRT-0002.808		



No.6 Ke Feng Road,Block 52,
ShenZhen Science & Industry Park
Noutou, ShenZhen, GuangDong, China
Tel:+86-755-26639495-7
Fax:+86-755-26632877
Postcode:518057

Data: 4 File: E:\2009 report data\Axis\ACS9QH233R.EM6 (24)

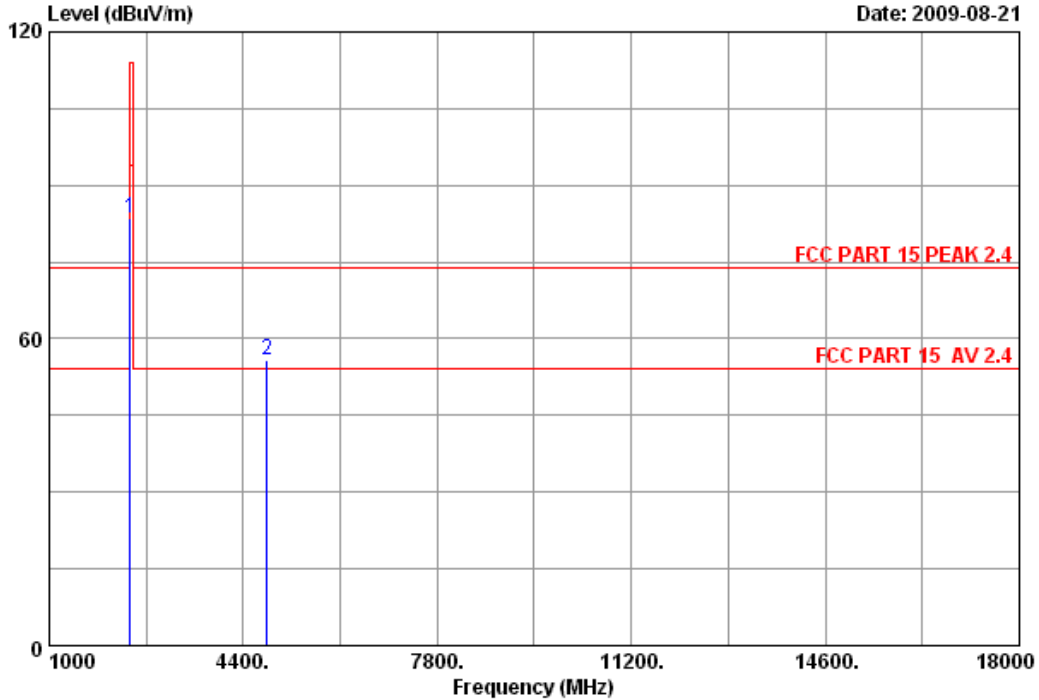

Site no. : 3m Chamber Data no. : 4
 Dis. / Ant. : 3m 3115(0905) Ant. pol. : VERTICAL
 Limit : FCC PART 15 PEAK 2.4
 Env. / Ins. : 25*C/60% Engineer :Power Feng
 EUT : Wireless Drum Receiver for PS2&PS3
 Power : DC 5V from PS3 input AC120V/60Hz
 Test mode : Tx 2410MHz
 Model/no. : PRT-0002.808

	Ant.	Cable	Amp.	Emission					
Freq.	Factor	loss	Factor	Reading	Level	Limits	Margin	Remark	
(MHz)	(dB/m)	(dB)	(dB)	(dbuv)	(dBuV/m)	(dBuV/m)	(dB)		
1	2410.000	28.48	7.66	35.95	83.51	83.70	114.00	30.30	Peak
2	4820.000	34.47	10.80	35.25	45.76	55.78	74.00	18.22	Peak

Remarks:

1. Emission Level= Antenna Factor + Cable Loss -Amp Factor + Reading.
2. The emission levels that are 20dB below the official limit are not reported.

Average emissions Level

Freq (MHz)	Ant. Plo.	Peak Level (dBuV/m)	PDCF (dB)	AV Level (dBuV/m)	AV Limit (dBuV/m)	Margin (dB)
4820.0	V	55.78	24.73	31.05	54	22.95

Note: AV Level= Peak Level – PDCF



No.6 Ke Feng Road,Block 52,
 ShenZhen Science & Industry Park
 Noutou, ShenZhen, GuangDong, China
 Tel:+86-755-26639495-7
 Fax:+86-755-26632877
 Postcode:518057

Data: 5 File: E:\2009 report data\A\axis\ACS9QH233R.EM6 (24)

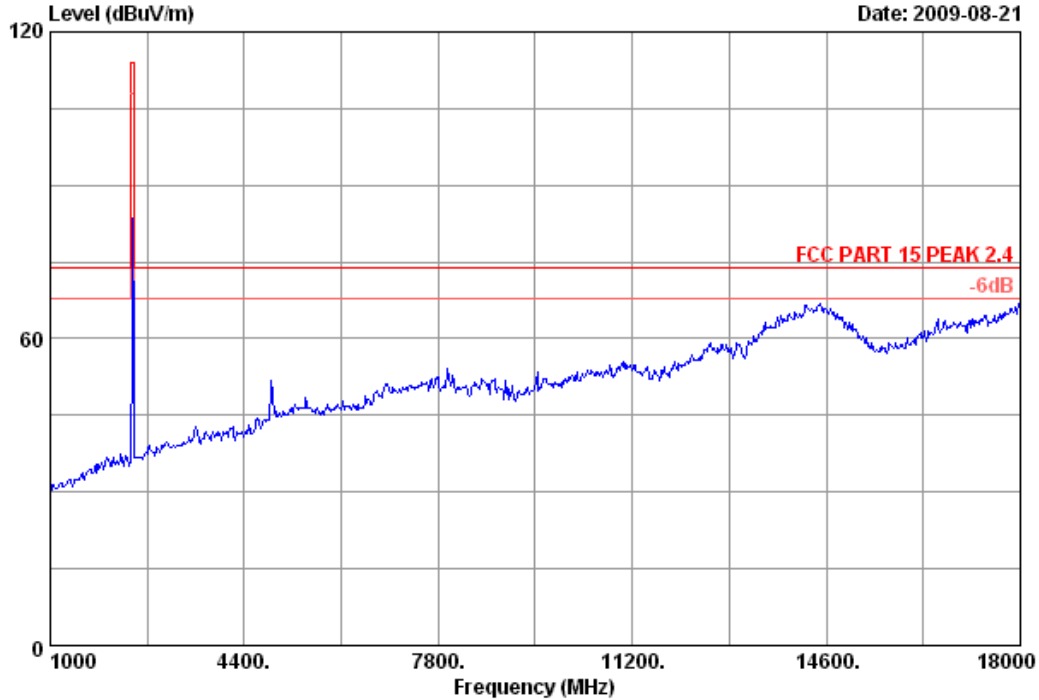

Site no.	: 3m Chamber	Data no.	: 5
Dis. / Ant.	: 3m 3115(O905)	Ant. pol.	: HORIZONTAL
Limit	: FCC PART 15 PEAK 2.4		
Env. / Ins.	: 25°C/60%	Engineer	: Power Feng
EUT	: Wireless Drum Receiver for PS2&PS3		
Power	: DC 5V from PS3 input AC120V/60Hz		
Test mode	: Tx 2440MHz		
Model/no.	: PRT-0002.808		



No.6 Ke Feng Road,Block 52,
ShenZhen Science & Industry Park
Noutou,ShenZhen,GuangDong,China
Tel:+86-755-26639495-7
Fax:+86-755-26632877
Postcode:518057

Data: 6 File: E:\2009 report data\A\axis\ACS9QH233R.EM6 (24)

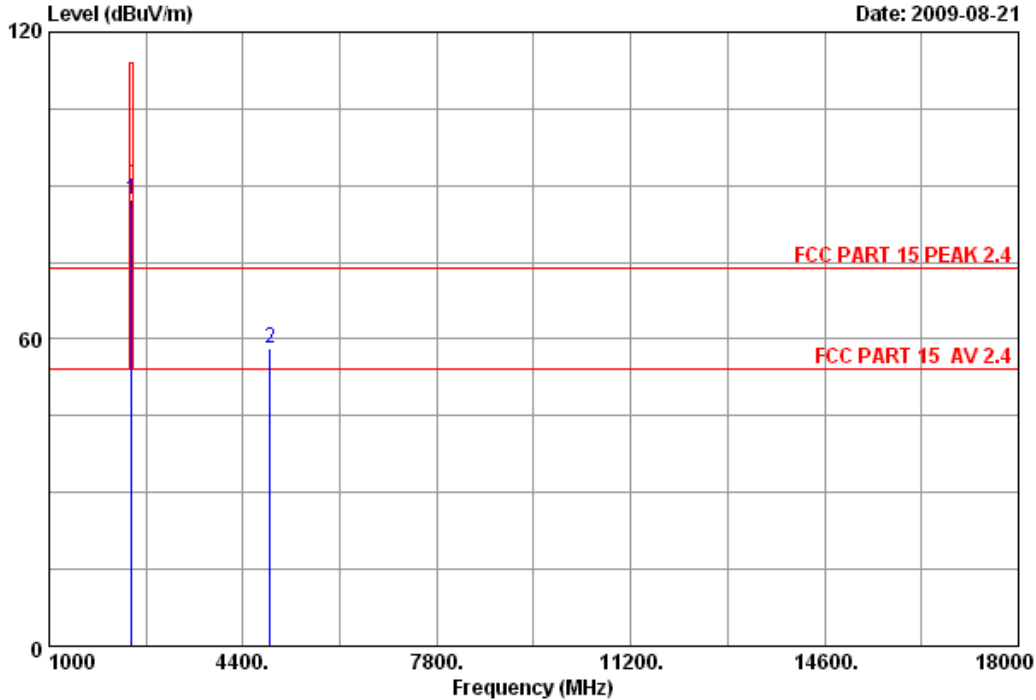

Site no. : 3m Chamber Data no. : 6
 Dis. / Ant. : 3m 3115(0905) Ant. pol. : HORIZONTAL
 Limit : FCC PART 15 PEAK 2.4
 Env. / Ins. : 25°C/60% Engineer : Power Feng
 EUT : Wireless Drum Receiver for PS2&PS3
 Power : DC 5V from PS3 input AC120V/60Hz
 Test mode : Tx 2440MHz
 Model/no. : PRT-0002.808

	Ant. Freq. (MHz)	Factor (dB/m)	Cable loss (dB)	Amp. Factor (dB)	Reading (dbuv)	Emission Level (dBuV/m)	Limits (dBuV/m)	Margin (dB)	Remark
1	2440.000	28.53	7.72	36.06	86.97	87.16	114.00	26.84	Peak
2	4880.000	34.78	10.95	35.36	47.86	58.23	74.00	15.77	Peak

Remarks:

- Emission Level= Antenna Factor + Cable Loss -Amp Factor + Reading.
- The emission levels that are 20dB below the official limit are not reported.

Average emissions Level

Freq (MHz)	Ant. Plo.	Peak Level (dBuV/m)	PDCF (dB)	AV Level (dBuV/m)	AV Limit (dBuV/m)	Margin (dB)
4880.0	V	58.23	24.73	33.5	54	20.5

Note: AV Level= Peak Level – PDCF



No.6 Ke Feng Road,Block 52,
 ShenZhen Science & Industry Park
 Noutou,ShenZhen,GuangDong,China
 Tel:+86-755-26639495-7
 Fax:+86-755-26632877
 Postcode:518057

Data: 7 File: E:\2009 report data\A\axis\ACS9QH233R.EM6 (24)

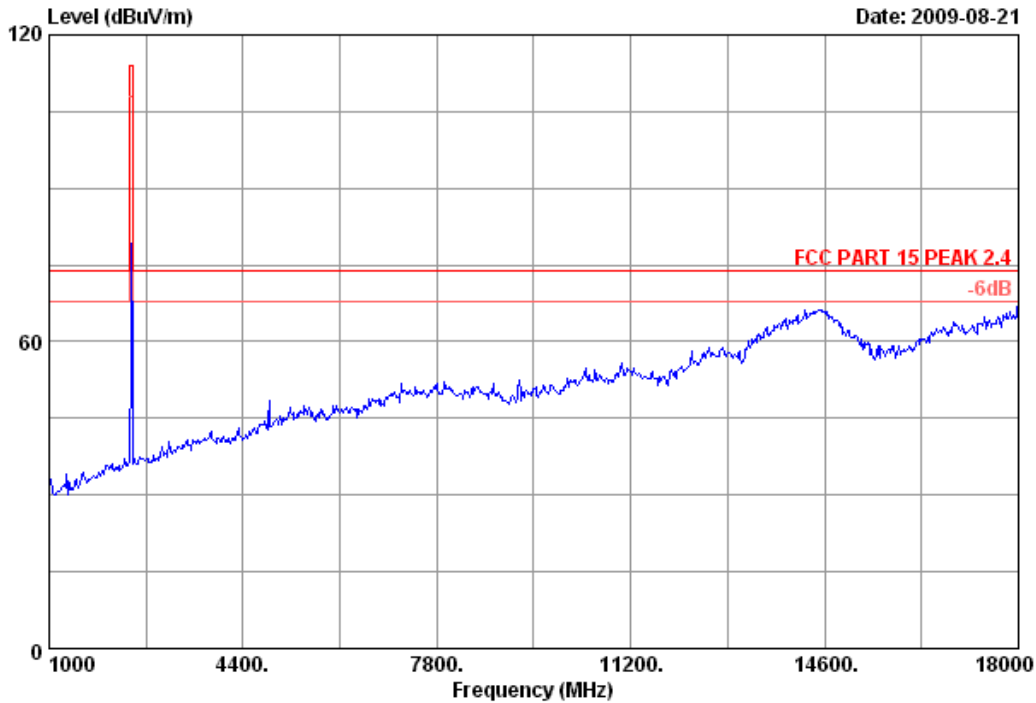

Site no.	: 3m Chamber	Data no.	: 7
Dis. / Ant.	: 3m 3115(0905)	Ant. pol.	: VERTICAL
Limit	: FCC PART 15 PEAK 2.4		
Env. / Ins.	: 25°C/60%	Engineer	: Power Feng
EUT	: Wireless Drum Receiver for PS2&PS3		
Power	: DC 5V from PS3 input AC120V/60Hz		
Test mode	: Tx 2440MHz		
Model/no.	: PRT-0002.808		



No.6 Ke Feng Road,Block 52,
ShenZhen Science & Industry Park
Noutou,ShenZhen,GuangDong,China
Tel:+86-755-26639495-7
Fax:+86-755-26632877
Postcode:518057

Data: 8 File: E:\2009 report data\A\axis\ACS9QH233R.EM6 (24)

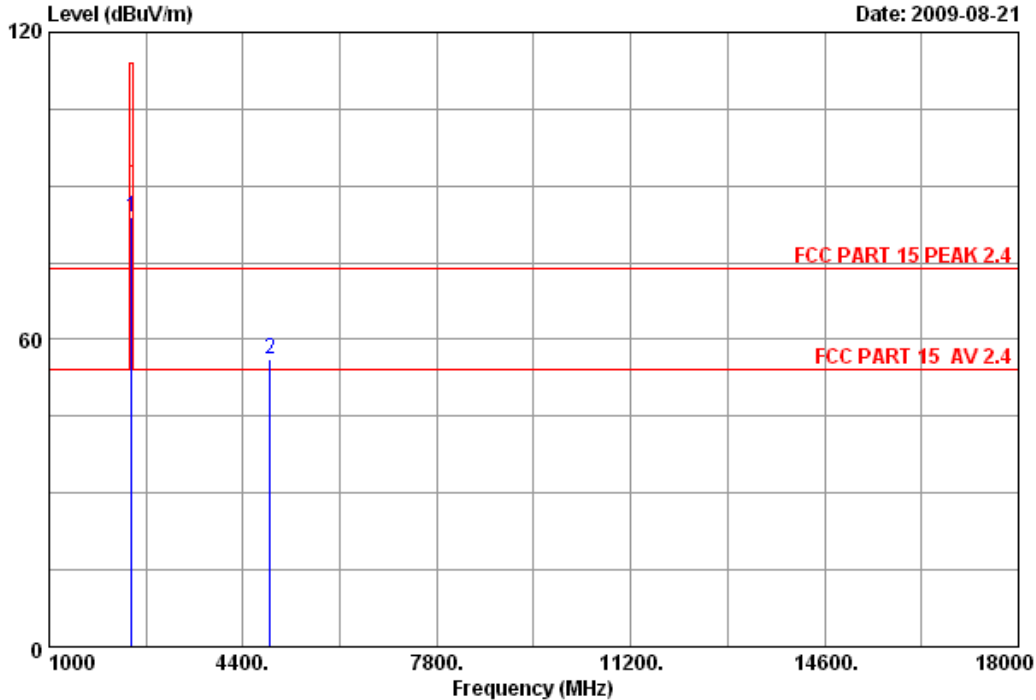

Site no. : 3m Chamber Data no. : 8
 Dis. / Ant. : 3m 3115(0905) Ant. pol. : VERTICAL
 Limit : FCC PART 15 PEAK 2.4
 Env. / Ins. : 25°C/60% Engineer : Power Feng
 EUT : Wireless Drum Receiver for PS2&PS3
 Power : DC 5V from PS3 input AC120V/60Hz
 Test mode : Tx 2440MHz
 Model/no. : PRT-0002.808

	Ant. Freq. (MHz)	Factor (dB/m)	Cable loss (dB)	Amp. Factor (dB)	Reading (dbuv)	Emission Level (dBuV/m)	Limits (dBuV/m)	Margin (dB)	Remark
1	2440.000	28.53	7.72	36.06	83.81	84.00	114.00	30.00	Peak
2	4880.000	34.78	10.95	35.36	45.74	56.11	74.00	17.89	Peak

Remarks:

- Emission Level= Antenna Factor + Cable Loss -Amp Factor + Reading.
- The emission levels that are 20dB below the official limit are not reported.

Average emissions Level

Freq (MHz)	Ant. Plo.	Peak Level (dBuV/m)	PDCF (dB)	AV Level (dBuV/m)	AV Limit (dBuV/m)	Margin (dB)
4880.0	H	56.11	24.73	31.38	54	22.62

Note: AV Level= Peak Level – PDCF



No.6 Ke Feng Road,Block 52,
 ShenZhen Science & Industry Park
 Noutou,ShenZhen,GuangDong,China
 Tel:+86-755-26639495-7
 Fax:+86-755-26632877
 Postcode:518057

Data: 9 File: E:\2009 report data\A\axis\ACS9QH233R.EM6 (24)

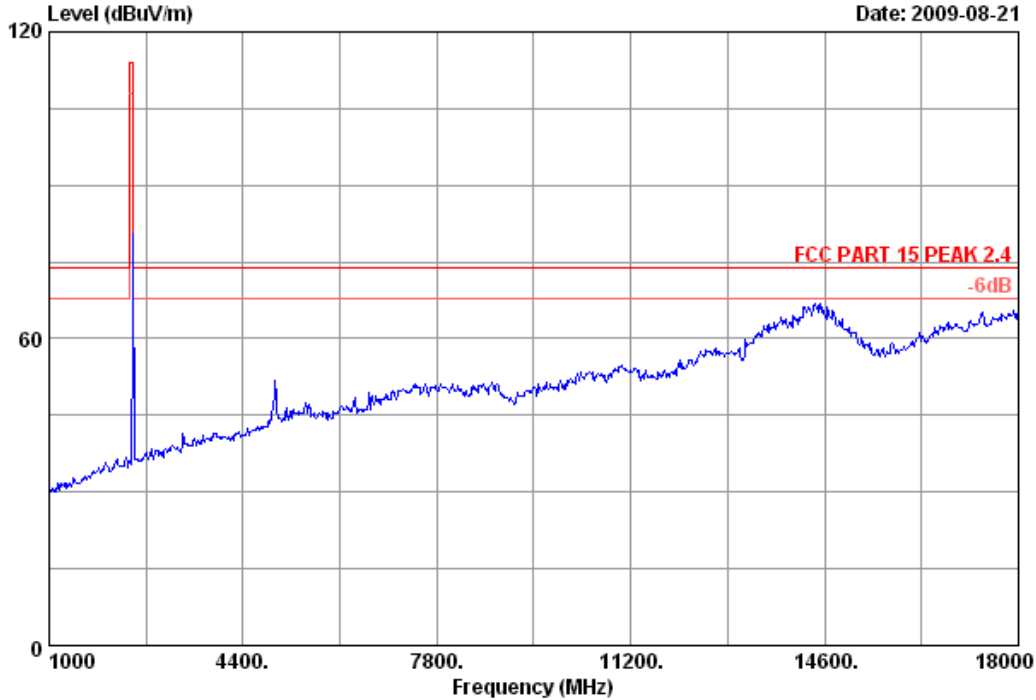

Site no.	: 3m Chamber	Data no.	: 9
Dis. / Ant.	: 3m 3115(0905)	Ant. pol.	: HORIZONTAL
Limit	: FCC PART 15 PEAK 2.4		
Env. / Ins.	: 25°C/60%	Engineer	: Power Feng
EUT	: Wireless Drum Receiver for PS2&PS3		
Power	: DC 5V from PS3 input AC120V/60Hz		
Test mode	: Tx 2469.2MHz		
Model/no.	: PRT-0002.808		



No.6 Ke Feng Road,Block 52,
ShenZhen Science & Industry Park
Noutou,ShenZhen,GuangDong,China
Tel:+86-755-26639495-7
Fax:+86-755-26632877
Postcode:518057

Data: 10 File: E:\2009 report data\A\axis\ACS9QH233R.EM6 (24)

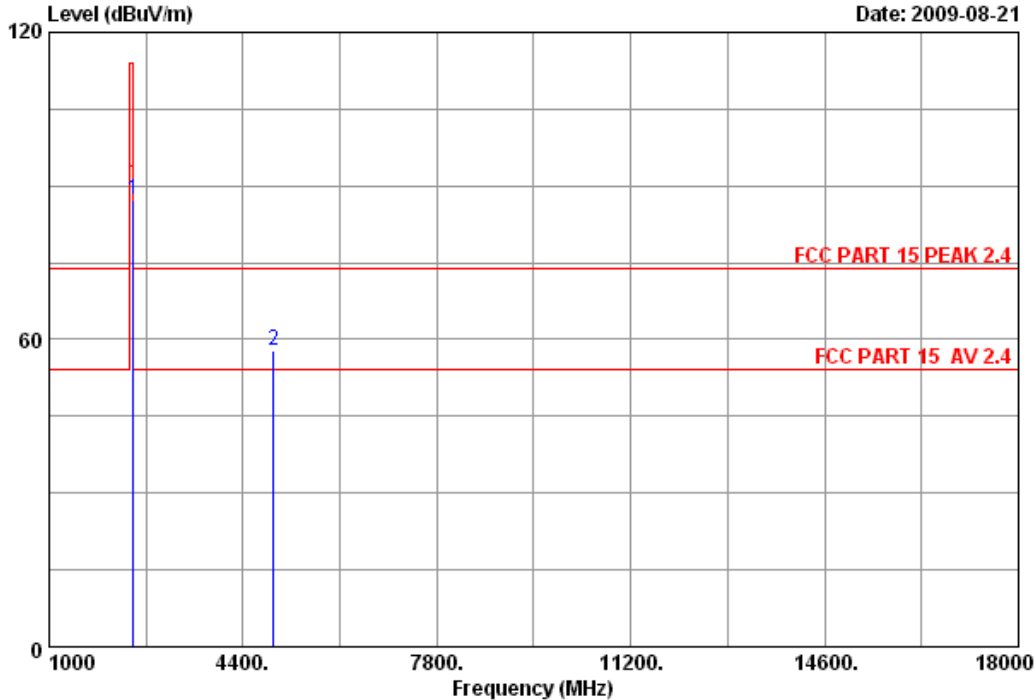

Site no. : 3m Chamber Data no. : 10
 Dis. / Ant. : 3m 3115(0905) Ant. pol. : HORIZONTAL
 Limit : FCC PART 15 PEAK 2.4
 Env. / Ins. : 25°C/60% Engineer : Power Feng
 EUT : Wireless Drum Receiver for PS2&PS3
 Power : DC 5V from PS3 input AC120V/60Hz
 Test mode : Tx 2469.2MHz
 Model/no. : PRT-0002.808

	Freq. (MHz)	Ant. Factor (dB/m)	Cable loss (dB)	Amp. Factor (dB)	Reading (dbuv)	Emission Level (dBuV/m)	Limits (dBuV/m)	Margin (dB)	Remark
1	2469.200	28.55	7.72	36.02	86.94	87.19	114.00	26.81	Peak
2	4938.400	35.19	11.03	35.40	47.08	57.90	74.00	16.10	Peak

Remarks:

- Emission Level= Antenna Factor + Cable Loss -Amp Factor + Reading.
- The emission levels that are 20dB below the official limit are not reported.

Average emissions Level

Freq (MHz)	Ant. Plo.	Peak Level (dBuV/m)	PDCF (dB)	AV Level (dBuV/m)	AV Limit (dBuV/m)	Margin (dB)
4938.4	V	57.90	24.73	33.17	54	20.83

Note: AV Level= Peak Level – PDCF



No.6 Ke Feng Road,Block 52,
 ShenZhen Science & Industry Park
 Noutou,ShenZhen,GuangDong,China
 Tel:+86-755-26639495-7
 Fax:+86-755-26632877
 Postcode:518057

Data: 11 File: E:\2009 report data\A\axis\ACS9QH233R.EM6 (24)

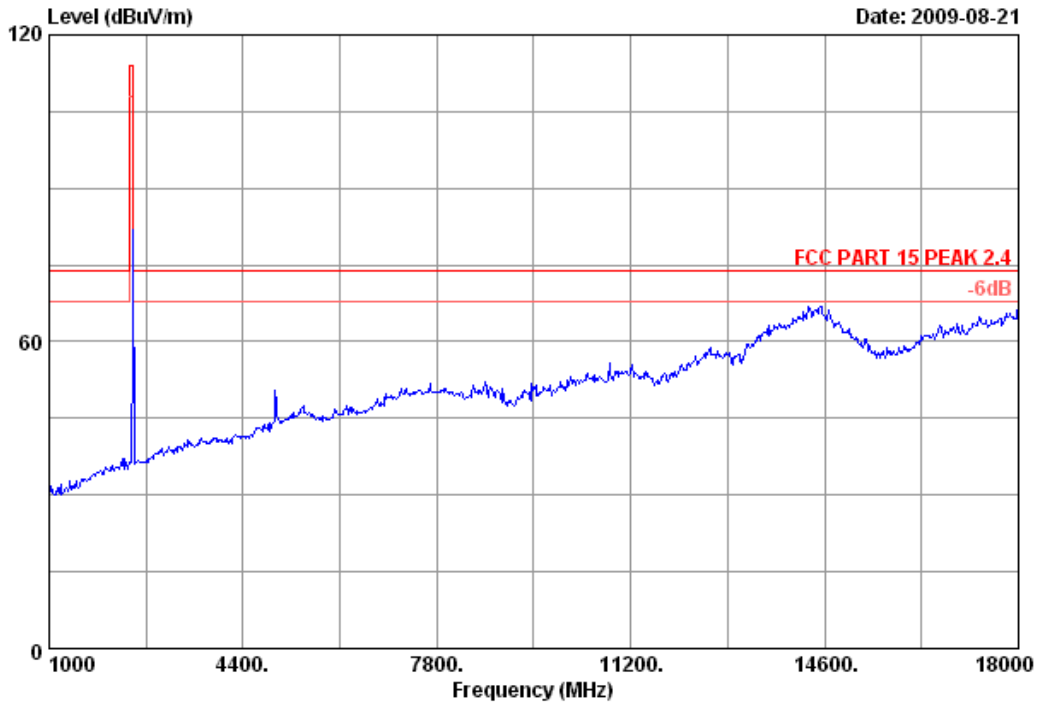

Site no.	: 3m Chamber	Data no.	: 11
Dis. / Ant.	: 3m 3115(0905)	Ant. pol.	: VERTICAL
Limit	: FCC PART 15 PEAK 2.4		
Env. / Ins.	: 25°C/60%	Engineer	: Power Feng
EUT	: Wireless Drum Receiver for PS2&PS3		
Power	: DC 5V from PS3 input AC120V/60Hz		
Test mode	: Tx 2469.2MHz		
Model/no.	: PRT-0002.808		



No.6 Ke Feng Road,Block 52,
ShenZhen Science & Industry Park
Noutou,ShenZhen,GuangDong,China
Tel:+86-755-26639495-7
Fax:+86-755-26632877
Postcode:518057

Data: 12 File: E:\2009 report data\A\axis\ACS9QH233REM6 (24)

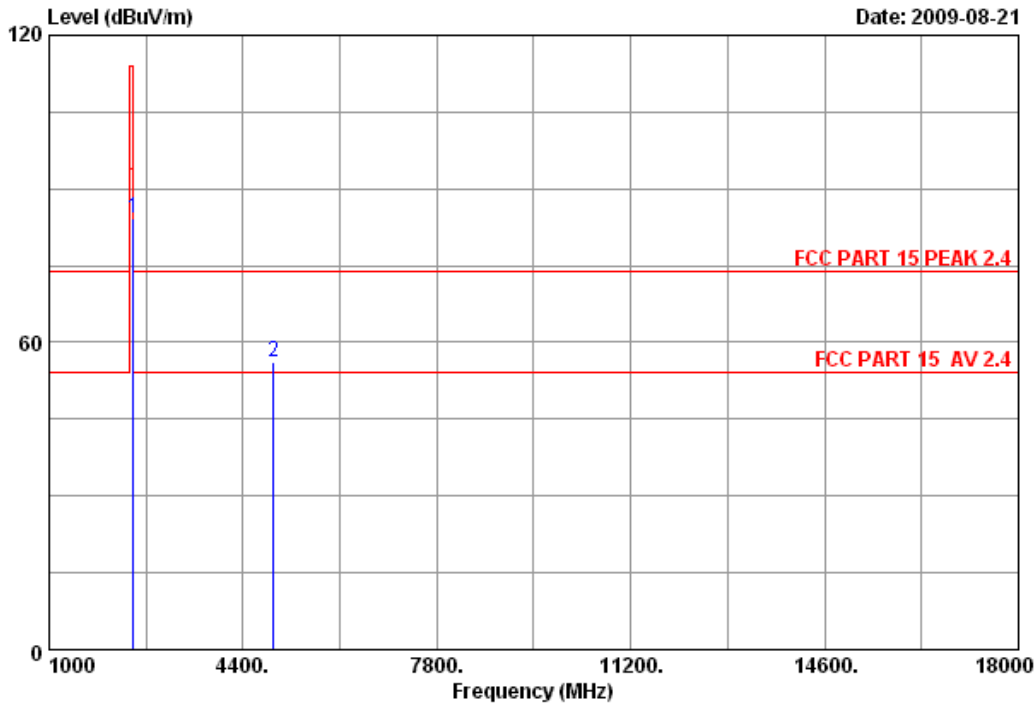

Site no. : 3m Chamber Data no. : 12
 Dis. / Ant. : 3m 3115(0905) Ant. pol. : VERTICAL
 Limit : FCC PART 15 PEAK 2.4
 Env. / Ins. : 25°C/60% Engineer : Power Feng
 EUT : Wireless Drum Receiver for PS2&PS3
 Power : DC 5V from PS3 input AC120V/60Hz
 Test mode : Tx 2469.2MHz
 Model/no. : PRT-0002.808

	Ant. Freq. (MHz)	Factor (dB/m)	Cable loss (dB)	Amp. Factor (dB)	Reading (dbuv)	Emission Level (dBuV/m)	Limits (dBuV/m)	Margin (dB)	Remark
1	2469.200	28.55	7.72	36.02	83.91	84.16	114.00	29.84	Peak
2	4938.400	35.19	11.03	35.40	45.43	56.25	74.00	17.75	Peak

Remarks:

- Emission Level= Antenna Factor + Cable Loss -Amp Factor + Reading.
- The emission levels that are 20dB below the official limit are not reported.

Average emissions Level

Freq (MHz)	Ant. Plo.	Peak Level (dBuV/m)	PDCF (dB)	AV Level (dBuV/m)	AV Limit (dBuV/m)	Margin (dB)
4938.4	H	56.25	24.73	31.52	54	22.48

Note: AV Level= Peak Level – PDCF

4.8. Duty factor

Average level = Peak level – Duty factor

Duty factor = $20 \log(1/x) = 24.73 \text{ dB}$

$X = \text{Tx on} / (\text{Tx on} + \text{Tx off}) = 0.58/10.00$

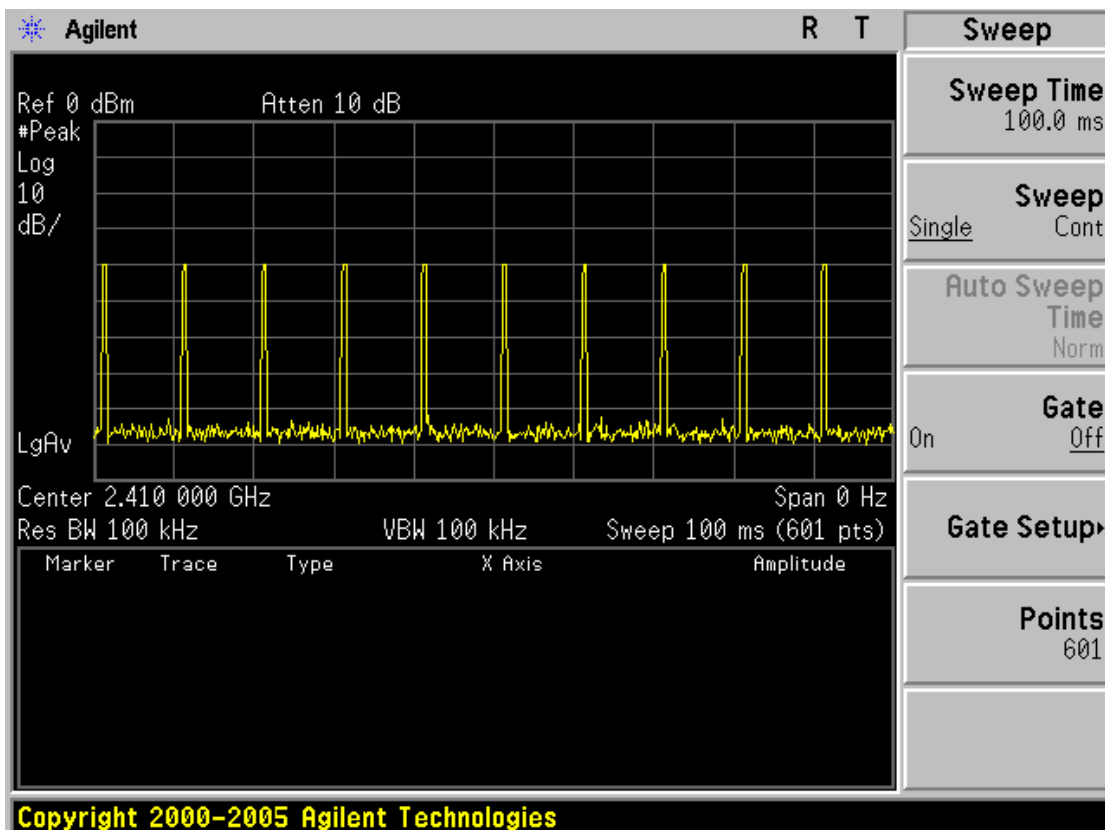
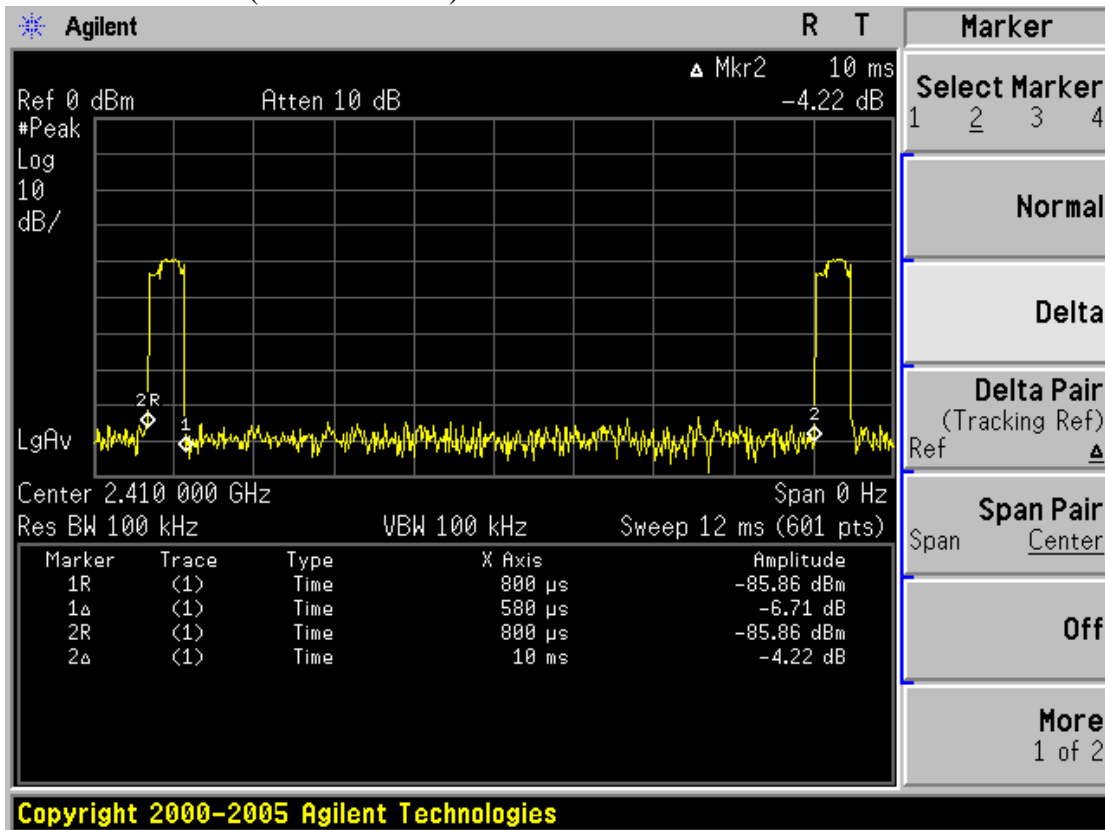

5. 20DB BANDWIDTH TEST

5.1. Test Equipment

Item	Equipment	Manufacturer	Model No.	Serial No.	Last Cal.	Cal. Interval
1	Spectrum Analyzer	Agilent	E4446A	US44300459	May,08, 09	1 Year
2	Attenuator	Agilent	8491B	MY39262165	May,08, 09	1 Year
3	RF Cable	Hubersuhner	SUCOFLEX 102	28618/2	May,08, 09	1Year

5.2. Limit

Intentional radiators operating under the alternative provisions to the general emission limits, as contained in §§ 15.217 through 15.257 and in Subpart E of this part, must be designed to ensure that the 20 dB bandwidth of the emission, or whatever bandwidth may otherwise be specified in the specific rule section under which the equipment operates, is contained within the frequency band designated in the rule section under which the equipment is operated.

5.3. Test Results

CH	20dB Bandwidth (kHz)	Limit (kHz)	Conclusion
(Low)	916.818	---	PASS
(Mid)	899.362	---	PASS
(High)	910.334	---	PASS

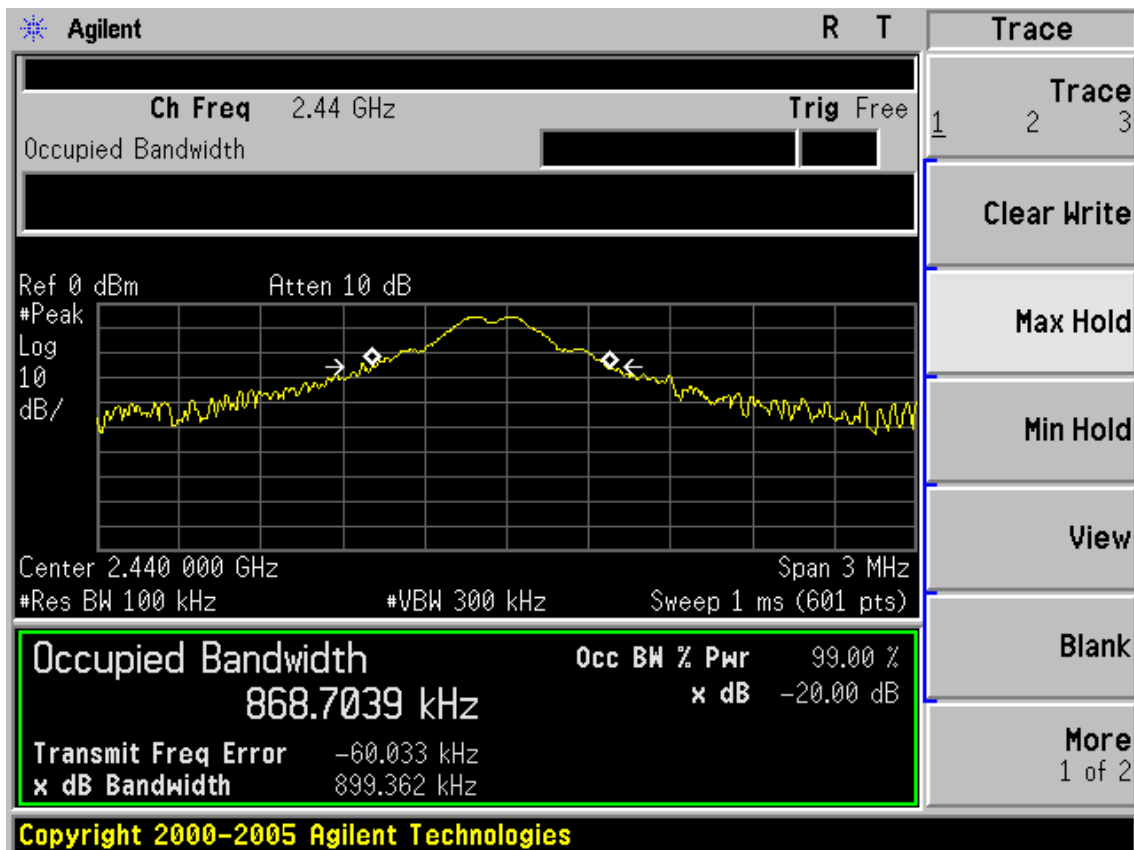
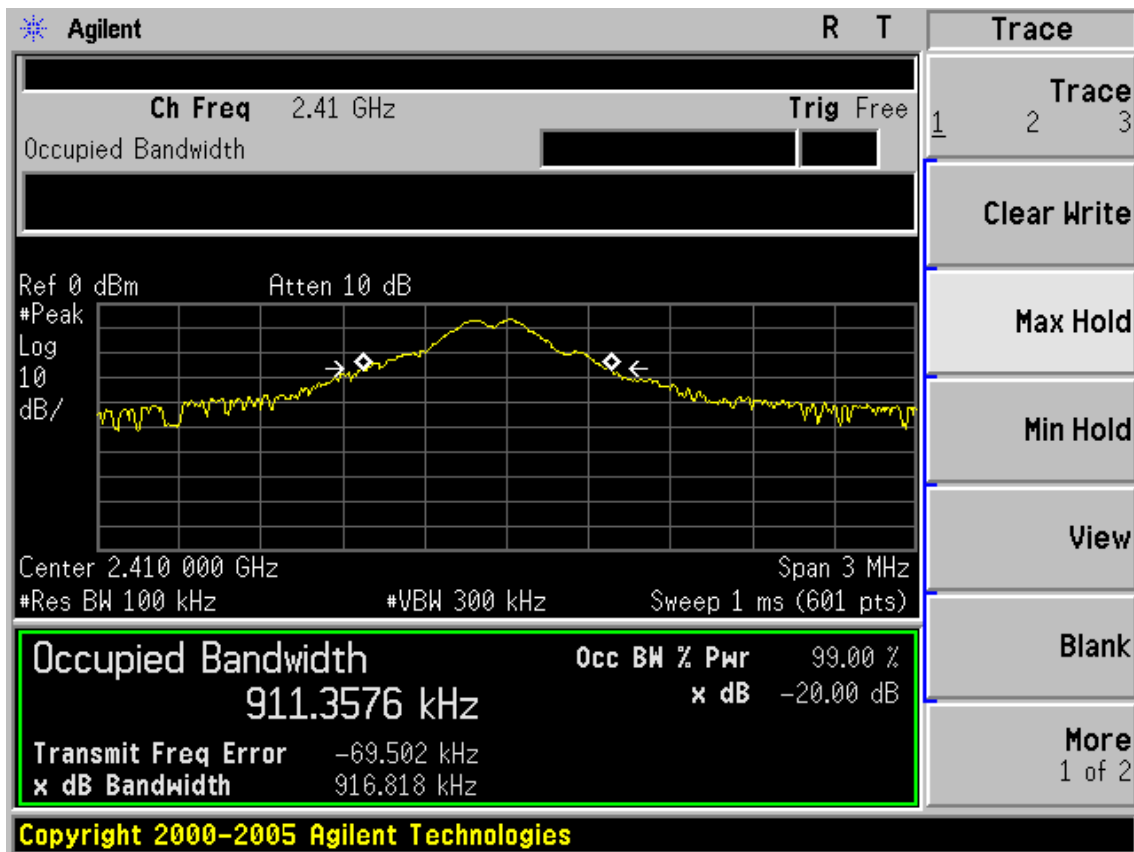

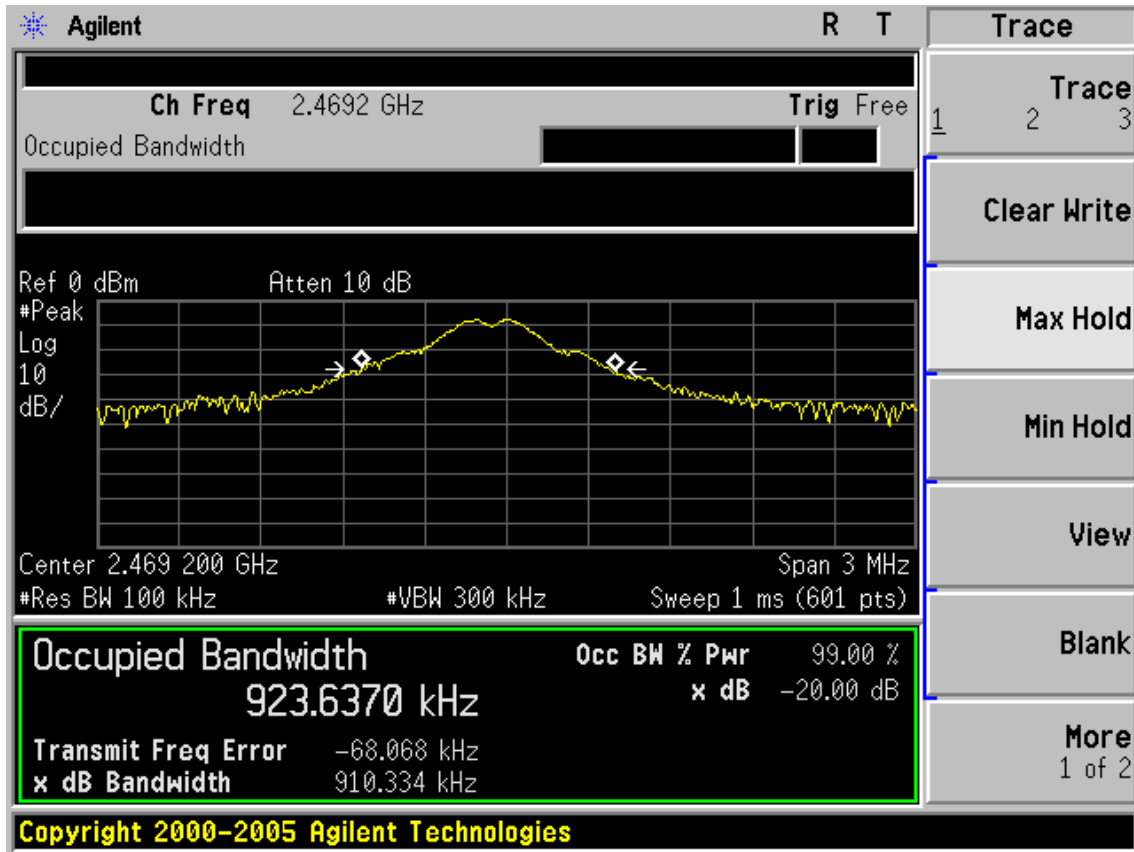

6. BAND EDGE COMPLIANCE TEST

6.1. Test Equipment

Item	Equipment	Manufacturer	Model No.	Serial No.	Last Cal.	Cal. Interval
1	Spectrum Analyzer	Agilent	E4446A	US44300459	May,08, 09	1 Year
2	Horn Antenna	EMCO	3115	9607-4877	May, 27, 08	1.5 Year
3	Amplifier	Agilent	8449B	3008A02495	Nov 24.08	1 Year
4	RF Cable	Hubersuhner	SUCOFLEX 102	28620/2	May,08, 09	1 Year
5	RF Cable	Hubersuhner	SUCOFLEX 102	271471/4	May,08, 09	1 Year
6	RF Cable	Hubersuhner	SUCOFLEX 102	29086/2	May,08, 09	1 Year

6.2. Limit

All the lower and upper band-edges emissions appearing within 2310MHz to 2390MHz and 2483.5MHz to 2500MHz restricted frequency bands shall not exceed the limits shown in 15.209, all the other emissions outside operation frequency band 2400MHz to 2483.5MHz shall be at least 20dB below the fundamental emissions, or comply with 15.209 limits.

6.3. Test Produce

1. The EUT is placed on a turntable, which is 0.8m above the ground plane and worked at highest radiated power.
2. The turntable was rotated for 360 degrees to determine the position of maximum emission level.
3. EUT is set 3m away from the receiving antenna, which is varied from 1m to 4m to find out the highest emission.
4. Set the spectrum analyzer in the following setting in order to capture the lower and upperband-edges of the emission:
 - (a) PEAK: RBW=VBW=1MHz, PK detector, Sweep=AUTO

6.4. Test Results

Pass (The testing data was attached in the next pages.)

All the levels PK measured and comply with average limit, so the average levels were deemed to comply with average limit



No.6 Ke Feng Road,Block 52,
 ShenZhen Science & Industry Park
 Noutou, ShenZhen, Guangdong, China
 Tel:+86-755-26639495-7
 Fax:+86-755-26632877
 Postcode:518057

Data: 25 File: E:\2009 report data\A\axis\ACS90H233RLEM6 (32)

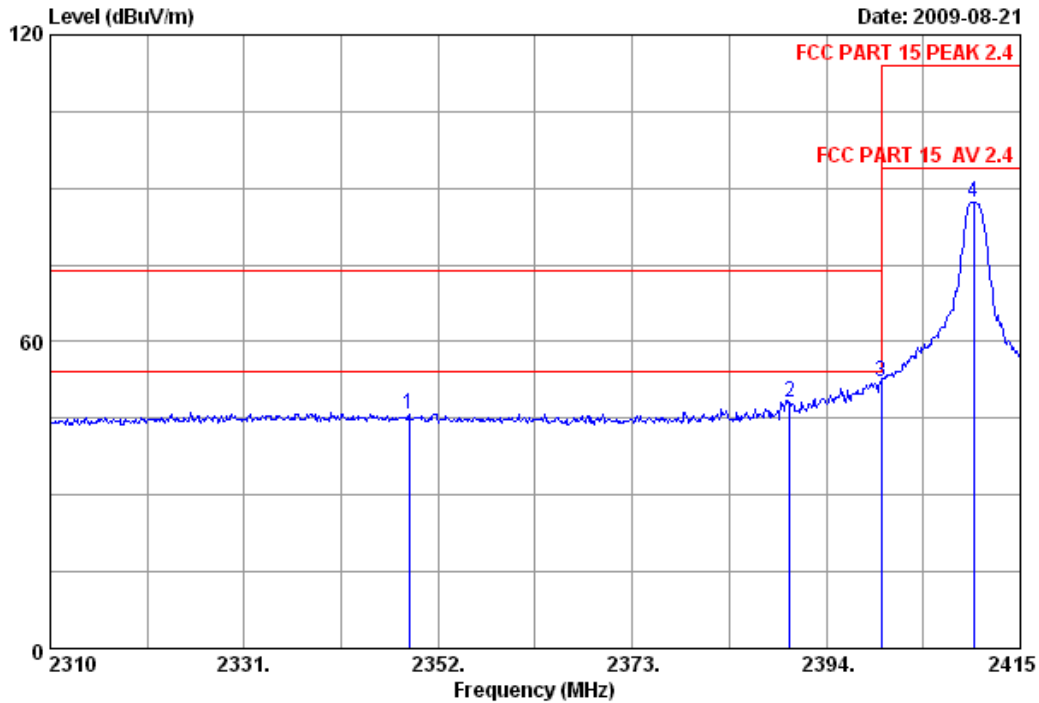

Site no. : 3m Chamber Data no. : 25
 Dis. / Ant. : 3m 3115(0905) Ant. pol. : HORIZONTAL
 Limit : FCC PART 15 PEAK 2.4
 Env. / Ins. : 25°C/60% Engineer : Power Feng
 EUT : Wireless Drum Receiver for PS2&PS3
 Power : DC 5V from PS3 input AC120V/60Hz
 Test mode : Tx 2410MHz
 Model/no. : PRT-0002.808

	Ant.	Cable	Amp.	Emission				
Freq.	Factor	loss	Factor	Reading	Level	Limits	Margin	Remark
(MHz)	(dB/m)	(dB)	(dB)	(dbuv)	(dBuV/m)	(dBuV/m)	(dB)	
1 2348.850	28.38	7.61	35.99	45.93	45.93	74.00	28.07	Peak
2 2390.000	28.46	7.66	36.09	48.15	48.18	74.00	25.82	Peak
3 2400.000	28.46	7.66	36.09	52.12	52.15	74.00	21.85	Peak
4 2410.000	28.48	7.66	35.95	87.01	87.20	114.00	26.80	Peak

Remarks:

1. Emission Level= Antenna Factor + Cable Loss -Amp Factor + Reading.
2. The emission levels that are 20dB below the official limit are not reported.



No.6 Ke Feng Road,Block 52,
 ShenZhen Science & Industry Park
 Noutou, ShenZhen, Guangdong, China
 Tel:+86-755-26639495-7
 Fax:+86-755-26632877
 Postcode:518057

Data: 26 File: E:\2009 report data\A\axis\ACS90H233RLEM6 (32)

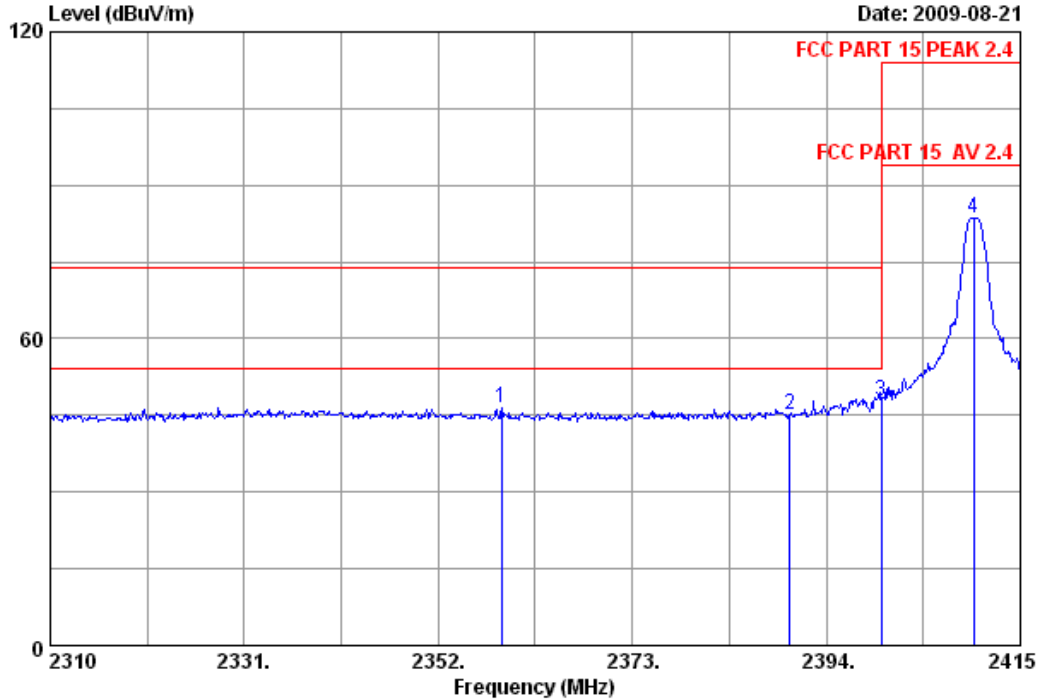

Site no. : 3m Chamber Data no. : 26
 Dis. / Ant. : 3m 3115(0905) Ant. pol. : VERTICAL
 Limit : FCC PART 15 PEAK 2.4
 Env. / Ins. : 25°C/60% Engineer : Power Feng
 EUT : Wireless Drum Receiver for PS2&PS3
 Power : DC 5V from PS3 input AC120V/60Hz
 Test mode : Tx 2410MHz
 Model/no. : PRT-0002.808

	Ant.	Cable	Amp.	Emission				
Freq.	Factor	loss	Factor	Reading	Level	Limits	Margin	Remark
(MHz)	(dB/m)	(dB)	(dB)	(dbuv)	(dBuV/m)	(dBuV/m)	(dB)	
1 2358.825	28.41	7.61	35.91	46.25	46.36	74.00	27.64	Peak
2 2390.000	28.46	7.66	36.09	45.03	45.06	74.00	28.94	Peak
3 2400.000	28.46	7.66	36.09	47.79	47.82	74.00	26.18	Peak
4 2410.000	28.48	7.66	35.95	83.54	83.73	114.00	30.27	Peak

Remarks:

1. Emission Level= Antenna Factor + Cable Loss -Amp Factor + Reading.
2. The emission levels that are 20dB below the official limit are not reported.



No.6 Ke Feng Road,Block 52,
ShenZhen Science & Industry Park
Noutou, ShenZhen, Guangdong, China
Tel:+86-755-26639495-7
Fax:+86-755-26632877
Postcode:518057

Data: 27 File: E:\2009 report data\A\axis\ACS90H233RLEM6 (32)

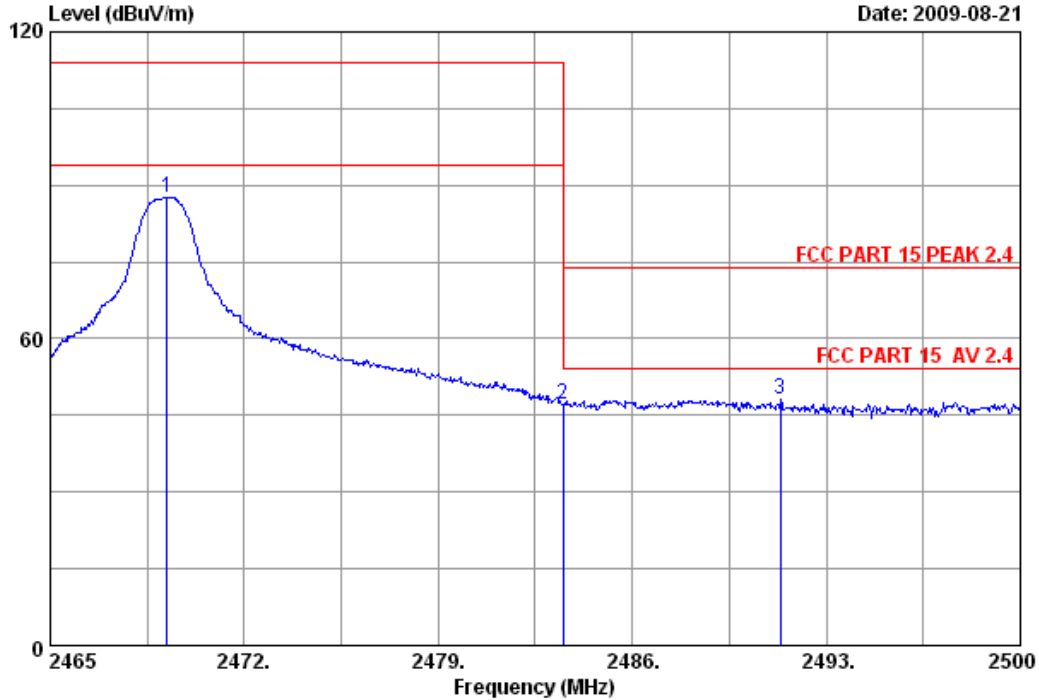

Site no. : 3m Chamber Data no. : 27
 Dis. / Ant. : 3m 3115(0905) Ant. pol. : HORIZONTAL
 Limit : FCC PART 15 PEAK 2.4
 Env. / Ins. : 25°C/60% Engineer :Power Feng
 EUT : Wireless Drum Receiver for PS2&PS3
 Power : DC 5V from PS3 input AC120V/60Hz
 Test mode : Tx 2469.2MHz
 Model/no. : PRT-0002.808

	Ant.	Cable	Amp.	Emission				
Freq.	Factor	loss	Factor	Reading	Level	Limits	Margin	Remark
(MHz)	(dB/m)	(dB)	(dB)	(dbuv)	(dBuV/m)	(dBuV/m)	(dB)	
1 2469.200	28.55	7.72	36.02	87.28	87.53	114.00	26.47	Peak
2 2483.500	28.58	7.77	35.97	46.73	47.11	74.00	26.89	Peak
3 2491.355	28.60	7.77	36.00	47.61	47.98	74.00	26.02	Peak

Remarks:

1. Emission Level= Antenna Factor + Cable Loss -Amp Factor + Reading.
2. The emission levels that are 20dB below the official limit are not reported.



No.6 Ke Feng Road,Block 52,
 ShenZhen Science & Industry Park
 Noutou, ShenZhen, Guangdong, China
 Tel:+86-755-26639495-7
 Fax:+86-755-26632877
 Postcode:518057

Data: 28 File: E:\2009 report data\A\axis\ACS9QH233RLEM6 (32)

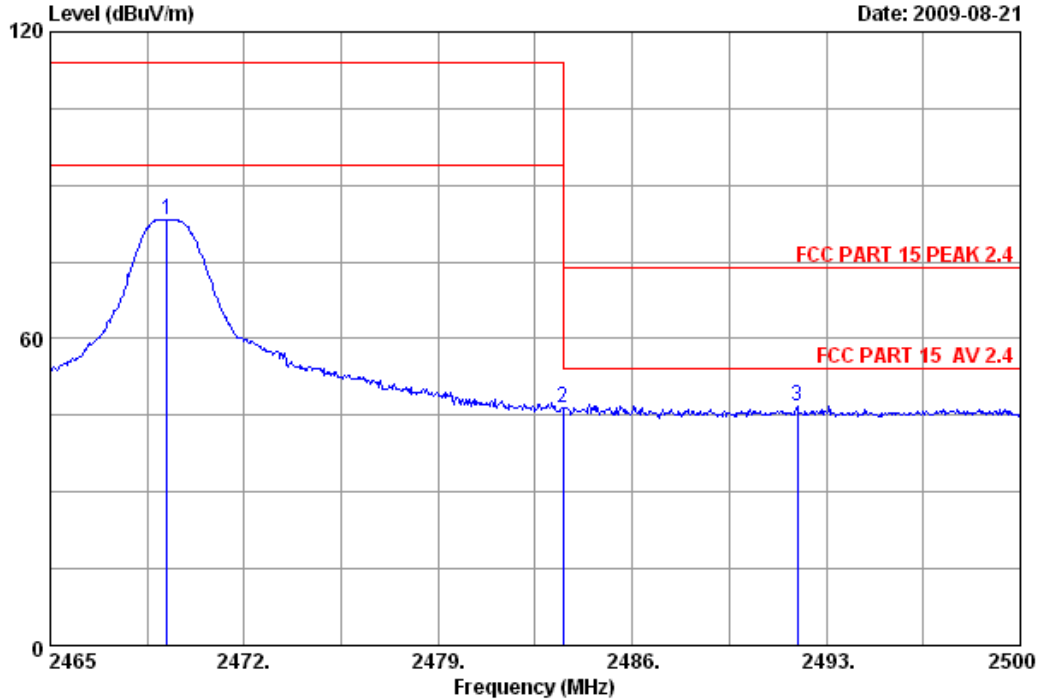

Site no. : 3m Chamber Data no. : 28
 Dis. / Ant. : 3m 3115(0905) Ant. pol. : VERTICAL
 Limit : FCC PART 15 PEAK 2.4
 Env. / Ins. : 25°C/60% Engineer : Power Feng
 EUT : Wireless Drum Receiver for PS2&PS3
 Power : DC 5V from PS3 input AC120V/60Hz
 Test mode : Tx 2469.2MHz
 Model/no. : PRT-0002.808

	Ant.	Cable	Amp.	Emission				
Freq.	Factor	loss	Factor	Reading	Level	Limits	Margin	Remark
(MHz)	(dB/m)	(dB)	(dB)	(dbuv)	(dBuV/m)	(dBuV/m)	(dB)	
1 2469.200	28.55	7.72	36.02	83.08	83.33	114.00	30.67	Peak
2 2483.500	28.58	7.77	35.97	45.99	46.37	74.00	27.63	Peak
3 2491.950	28.60	7.77	36.00	46.54	46.91	74.00	27.09	Peak

Remarks:

1. Emission Level= Antenna Factor + Cable Loss -Amp Factor + Reading.
2. The emission levels that are 20dB below the official limit are not reported.

7. DEVIATION TO TEST SPECIFICATIONS

[NONE]