



FCC 47 CFR PART 24 SUBPART E

TEST REPORT

for

GXW Wireless Camera

Model: STC-GX45NGW

Brand: Stealth Cam, LLC

Test Report Number:

C150420Z02-RP1

Issued Date: May 26, 2015

Issued for

K-Mark Industrial Limited.

Flat A, 7/F., Mai On Ind. Bldg 17-21 Kung Yip St Kwai Chung Hong Kong

Issued by:

Compliance Certification Services (Shenzhen) Inc.

No.10-1 Mingkeda Logistics park, No.18, Huanguan South Rd.,

Guan Lan Town, Baoan District, Shenzhen, China

TEL: 86-755-28055000

FAX: 86-755-28055221



TESTING CERT #2861.01

Note: This report shall not be reproduced except in full, without the written approval of Compliance Certification Service (Shenzhen) Inc. This document may be altered or revised by Compliance Certification Service (Shenzhen) Inc. personnel only, and shall be noted in the revision section of the document. The client should not use it to claim product endorsement by TAF, A2LA, NVLAP, NIST or any government agencies. The TEST RESULTS in the report only apply to the tested sample.



Revision History

Rev.	Issue Data	Revisions	Effect Page	Revised By
00	May 7, 2015	Initial Issue	ALL	Sabrina Wang
01	October 18, 2016	Update Report	ALL	Nancy Fu

Rev.01 (C160928Z09-PR1):

1. The applicant updated the antenna and the hardware version based on the original Report No.: C150420Z02-RP1. After reassessment, the ERP & EIRP and Field Strength of Spurious Radiation Measurement were retested.
2. The other information, please refer to the Report No.: C150420Z02-RP1 and this report.



TABLE OF CONTENTS

1. TEST CERTIFICATION 4

2. EUT DESCRIPTION..... 5

3. TEST METHODOLOGY..... 6

 3.1 EUT CONFIGURATION 6

 3.2 EUT EXERCISE 6

 3.3 GENERAL TEST PROCEDURES 6

 3.4 DESCRIPTION OF TEST MODES 7

4. INSTRUMENT CALIBRATION 8

 4.1 MEASURING INSTRUMENT CALIBRATION 8

 4.2 DESCRIPTION OF SUPPORT UNITS..... 8

 4.3 CONFIGURATION OF SYSTEM UNDER TEST 8

5. FACILITIES AND ACCREDITATIONS 9

 5.1 FACILITIES 9

 5.2 EQUIPMENT 9

 5.3 ACCREDITATIONS 9

 5.4 MEASUREMENT UNCERTAINTY 10

6. FCC PART 24 REQUIREMENTS 11

 6.1 PEAK POWER 11

 6.2 AVERAGE POWER 13

 6.3 PEAK TO AVERAGE RATIO 15

 6.4 ERP & EIRP MEASUREMENT 18

 6.5 OCCUPIED BANDWIDTH MEASUREMENT 22

 6.6 OUT OF BAND EMISSION AT ANTENNA TERMINALS 26

 6.7 FIELD STRENGTH OF SPURIOUS RADIATION MEASUREMENT 39

 6.8 FREQUENCY STABILITY V.S. TEMPERATURE MEASUREMENT 48

 6.9 FREQUENCY STABILITY V.S. VOLTAGE MEASUREMENT 51

 6.10 POWERLINE CONDUCTED EMISSIONS 53



1. TEST CERTIFICATION

Product	GXW Wireless Camera
Model	STC-GX45NGW
Brand	Stealth Cam, LLC
Tested	April 20~ May 25, 2015 & September 28~ October 18, 2016
Applicant	K-Mark Industrial Limited. Flat A, 7/F., Mai On Ind. Bldg 17-21 Kung Yip St Kwai Chung Hong Kong
Manufacturer	K-Mark Industrial Limited. NiuHu Village, Guan Lan Town, ShenZhen City, China

APPLICABLE STANDARDS	
STANDARD	TEST RESULT
FCC 47 CFR Part 24 Subpart E	No non-compliance noted

We hereby certify that:

The above equipment was tested by Compliance Certification Service (Shenzhen) Inc. The test data, data evaluation, test procedures, and equipment configurations shown in this report were made in accordance with the procedures given in TIA/EIA-603-C: 2004 and the energy emitted by the sample EUT tested as described in this report is in compliance with conducted and radiated emission limits of FCC Rule FCC PART 24 Subpart E.

The TEST RESULTS of this report relate only to the tested sample identified in this report.

Approved by:

Reviewed by:

Sunday Hu
Supervisor of EMC Dept.
Compliance Certification Service (Shenzhen) Inc.

Ruby Zhang
Supervisor of Report Dept.
Compliance Certification Service (Shenzhen) Inc.



2. EUT DESCRIPTION

Product	GXW Wireless Camera
Model Number	STC-GX45NGW
Brand	Stealth Cam, LLC
Model Discrepancy	N/A
Identify Number	C150420Z02-RP1
Power Supply	1. DC5V supply by the PC 2. DC18V supply by the battery 3. DC12V supply by the DC power supply
Frequency Range	TX: 1850.2 ~ 1909.8 MHz RX: 1930 ~ 1989.8 MHz HSDPA / HSUPA Band II: 1852 ~ 1907.6 MHz
Transmit Power (ERP & EIRP Power)	HSDPA Band II: 24.58dBm
Modulation Technique	Release99: QPSK
Cellular Phone Protocol	HSDPA / HSUPA: Quadrature Phase Shift Keying (QPSK) with Root-raised cosine pulse shaping filters (roll off = 0.22)
Type of Emission	HSDPA Band II: 4M18F9W
Antenna Gain	HSDPA band II: 2 dBi
Temperature Range	0°C ~ +40°C
HSDPA Version	21.21
Hardware Version	DUC265DV1.3
Software Version	1.0

Note:

1. The sample selected for test was engineering sample that approximated to production product and was provided by manufacturer.
2. This submittal(s) (test report) is intended for FCC ID: VEPGL-GSMGXW01 filing to comply with Part 24 of the FCC 47 CFR Rules.



3. TEST METHODOLOGY

Both conducted and radiated testing were performed according to the procedures document on chapter 13 of ANSI C63.4: 2009, TIA/EIA-603-C: 2004 and FCC CFR 47, Part 2, PART 24 SUBPART E

3.1 EUT CONFIGURATION

The EUT configuration for testing is installed on RF field strength measurement to meet the Commissions requirement and operating in a manner that intends to maximize its emission characteristics in a continuous normal application.

3.2 EUT EXERCISE

The EUT was operated in the engineering mode to fix the TX frequency that was for the purpose of the measurements.

3.3 GENERAL TEST PROCEDURES

Conducted Emissions

The EUT is placed on the turntable, which is 0.8m above ground plane. According to the requirements in Section 13.1.4.1 of ANSI C63.4: 2009. Conducted emissions from the EUT measured in the frequency range between 0.15 MHz and 30MHz using CISPR Quasi-peak and average detector modes.

Radiated Emissions

The EUT is placed on a turn table, which is 0.8 m above ground plane. The turntable shall rotate 360 degrees to determine the position of maximum emission level. EUT is set 3m away from the receiving antenna, which varied from 1m to 4m to find out the highest emission. And also, each emission was to be maximized by changing the polarization of receiving antenna both horizontal and vertical. In order to find out the maximum emissions, exploratory radiated emission measurements were made according to the requirements in Section 13.1.4.1 of ANSI C63.4: 2009.



3.4 DESCRIPTION OF TEST MODES

The EUT (model: STC-GX45NGW) had been tested under operating condition.

EUT staying in continuous transmitting mode was programmed.

Band HSDPA / Band II and HSUPA / Band II were chosen for pre-testing, Band HSDPA / Band II were the worst case and print in the report.

HSDPA / Band II:

Channel Low (CH9262), Channel Mid (CH9400) and Channel High (CH9538) were chosen for full testing.

HSUPA / Band II:

Channel Low (CH9262), Channel Mid (CH9400) and Channel High (CH9538) were chosen for full testing.

After verification, all tests were carried out with the worst case test modes as shown below except radiated spurious emission below 1GHz and power line conducted emissions below 30MHz, which worst case was in normal link mode only.



4. INSTRUMENT CALIBRATION

4.1 MEASURING INSTRUMENT CALIBRATION

The measuring equipment, which was utilized in performing the tests documented herein, has been calibrated in accordance with the manufacturer's recommendations for utilizing calibration equipment, which is traceable to recognized national standards.

4.2 DESCRIPTION OF SUPPORT UNITS

The EUT has been tested as an independent unit together with other necessary accessories or support units. The following support units or accessories were used to form a representative test configuration during the tests.

No.	Equipment	Model No.	Serial No.	Certify No.	Brand	Data Cable	Power Cord
1	PC	Dcsmif	805CV2X	DoC	DELL	N/A	Unshielded, 1.80m
2	Monitor	E17OSC	CN-DOV539-6418 0-DAP-3E1S	DoC	DELL	Shielded, 1.50m	Unshielded, 1.50m
3	Mouse	KB212-B	CN09RRC447511 6809966	DoC	DELL	Unshielded, 1.50m	N/A
4	Keyboard	SK-8115	CN-0DJ313-71616 -82P-0YTB	DoC	DELL	Unshielded, 1.50m	N/A
5	Modem	MODEM1414	9013593	DoC	ACEEX	Unshielded, 1.40m	N/A
6	Printer	DESKJETD16 68	CN9CKCB2RG	DoC	HP	Unshielded, 1.20m	Unshielded, 1.50m
7	DC Power Supply	QJ3003XE	018389	DoC	N/A	N/A	N/A
8	SIM Card	N/A	N/A	DoC	N/A	N/A	N/A
9	SD Card	N/A	N/A	DoC	N/A	N/A	N/A

Note:

Grounding was established in accordance with the manufacturer's requirements and conditions for the intended use.

4.3 CONFIGURATION OF SYSTEM UNDER TEST

See test photographs attached in Appendix II for the actual connections between EUT and support equipment.



5. FACILITIES AND ACCREDITATIONS

5.1 FACILITIES

All measurement facilities used to collect the measurement data are located at **No.10-1 Mingkeda Logistics park, No.18, Huanguan South Rd., Guan Lan Town, Baoan District, Shenzhen, China**

The sites are constructed in conformance with the requirements of ANSI C63.4, ANSI C63.7 and CISPR Publication 22.

5.2 EQUIPMENT

Radiated emissions are measured with one or more of the following types of linearly polarized antennas: tuned dipole, biconical, log periodic, bi-log, and/or ridged waveguide, horn. Spectrum analyzers with pre-selectors and quasi-peak detectors are used to perform radiated measurements.

Conducted emissions are measured with Line Impedance Stabilization Networks and EMI Test Receivers.

Calibrated wideband preamplifiers, coaxial cables, and coaxial attenuators are also used for making measurements.

All receiving equipment conforms to CISPR Publication 16-1, "Radio Interference Measuring Apparatus and Measurement Methods."

5.3 ACCREDITATIONS

Our laboratories are accredited and approved by the following accreditation body according to ISO/IEC 17025.

USA	A2LA
China	CNAS

The measuring facility of laboratories has been authorized or registered by the following approval agencies.

USA	FCC
Japan	VCCI(C-4815, R-4320, T-2317, G-10624)
Canada	INDUSTRY CANADA
Taiwan	BSMI

Copies of granted accreditation certificates are available for downloading from our web site, <http://www.ccssz.com>



5.4 MEASUREMENT UNCERTAINTY

Parameter	Uncertainty
Radiated Emission, 30 to 200 MHz Test Site : 966(2)	+/-3.6880dB
Radiated Emission, 200 to 1000 MHz Test Site : 966(2)	+/-3.6695dB
Radiated Emission, 1 to 8 GHz	+/-5.1782dB
Radiated Emission, 9 to 40 GHz	+/-5.2173dB
Conducted Emissions	+/-3.6836dB
Band Width	178kHz
Peak Output Power MU	+/-1.906dB
Band Edge MU	+/-0.182dB
Channel Separation MU	416.178Hz
Duty Cycle MU	0.054ms
Frequency Stability MU	226Hz

Remark: This uncertainty represents an expanded uncertainty expressed at approximately the 95% confidence level using a coverage factor of $k=2$.



6. FCC 24 REQUIREMENTS

6.1 PEAK POWER

6.1.1 LIMIT

According to FCC §2.1046.

6.1.2 MEASUREMENT EQUIPMENT USED

Name of Equipment	Manufacturer	Model	Serial Number	Last Calibration	Due Calibration
Power Meter	Anritsu	ML2495A	1204003	02/28/2015	02/27/2016
Power Sensor	Anritsu	MA2411B	1126150	02/28/2015	02/27/2016
Universal Radio Communication Tester	Agilent	8960	MY48367671	09/04/2014	09/03/2015

Remark: Each piece of equipment is scheduled for calibration once a year.

6.1.3 TEST CONFIGURATION



6.1.4 TEST PROCEDURE

The transmitter output was connected to a calibrated attenuator, the other end of which was connected to a power meter. Transmitter output was read off the power meter in dBm. The power output at the transmitter antenna port was determined by adding the value of the attenuator to the power meter reading.



6.1.5 TEST RESULTS

No non-compliance noted.

Test Data

Test Mode	Channel	Frequency (MHz)	Peak Power (dBm)	Output Power (W)
HSDPA (BAND II)	9262	1852.40	24.61	0.28907
	9400	1880.00	24.79	0.30130
	9538	1907.60	24.31	0.26977

Remark: *The value of factor includes both the loss of cable and external attenuator*



6.2 AVERAGE POWER

6.2.1 LIMIT

For reporting purposes only.

6.2.2 MEASUREMENT EQUIPMENT USED

Name of Equipment	Manufacturer	Model	Serial Number	Last Calibration	Due Calibration
Power Meter	Anritsu	ML2495A	1204003	02/28/2015	02/27/2016
Power Sensor	Anritsu	MA2411B	1126150	02/28/2015	02/27/2016
Universal Radio Communication Tester	Agilent	8960	MY48367671	09/04/2014	09/03/2015

Remark: Each piece of equipment is scheduled for calibration once a year.

6.2.3 TEST CONFIGURATION



6.2.4 TEST PROCEDURE

The transmitter output was connected to a calibrated attenuator, the other end of which was connected to a power meter. Transmitter output was read off the power meter in dBm. The power output at the transmitter antenna port was determined by adding the value of the attenuator to the power meter reading.



6.2.5 TEST RESULTS

No non-compliance noted.

Test Data

Test Mode	Channel	Frequency (MHz)	AVG Power (dBm)	Output Power (W)
HSDPA (BAND II)	9262	1852.40	21.09	0.12853
	9400	1880.00	21.93	0.15596
	9538	1907.60	21.78	0.15066

Remark: The value of factor includes both the loss of cable and external attenuator



6.3 PEAK TO AVERAGE RATIO

6.3.1 LIMIT

In measuring transmissions in this band using an average power technique, the peak to-average ratio (PAR) of the transmission may not exceed 13 dB.

6.3.2 MEASUREMENT EQUIPMENT USED

Name of Equipment	Manufacturer	Model	Serial Number	Last Calibration	Due Calibration
Spectrum Analyzer	Agilent	N9010A	MY52221469	10/25/2014	10/24/2015
Universal Radio Communication Tester	Agilent	8960	MY48367671	09/04/2014	09/03/2015

Remark: Each piece of equipment is scheduled for calibration once a year.

6.3.3 TEST CONFIGURATION



6.3.4 TEST PROCEDURE

1. Set resolution/measurement bandwidth \geq signal's occupied bandwidth.
2. Set the number of counts to a value that stabilizes the measured CCDF curve.
3. Record the maximum PAPR level associated with a probability of 0.1%.

6.3.5 TEST RESULTS

No non-compliance noted



Test Plot
HSDPA (BAND II)

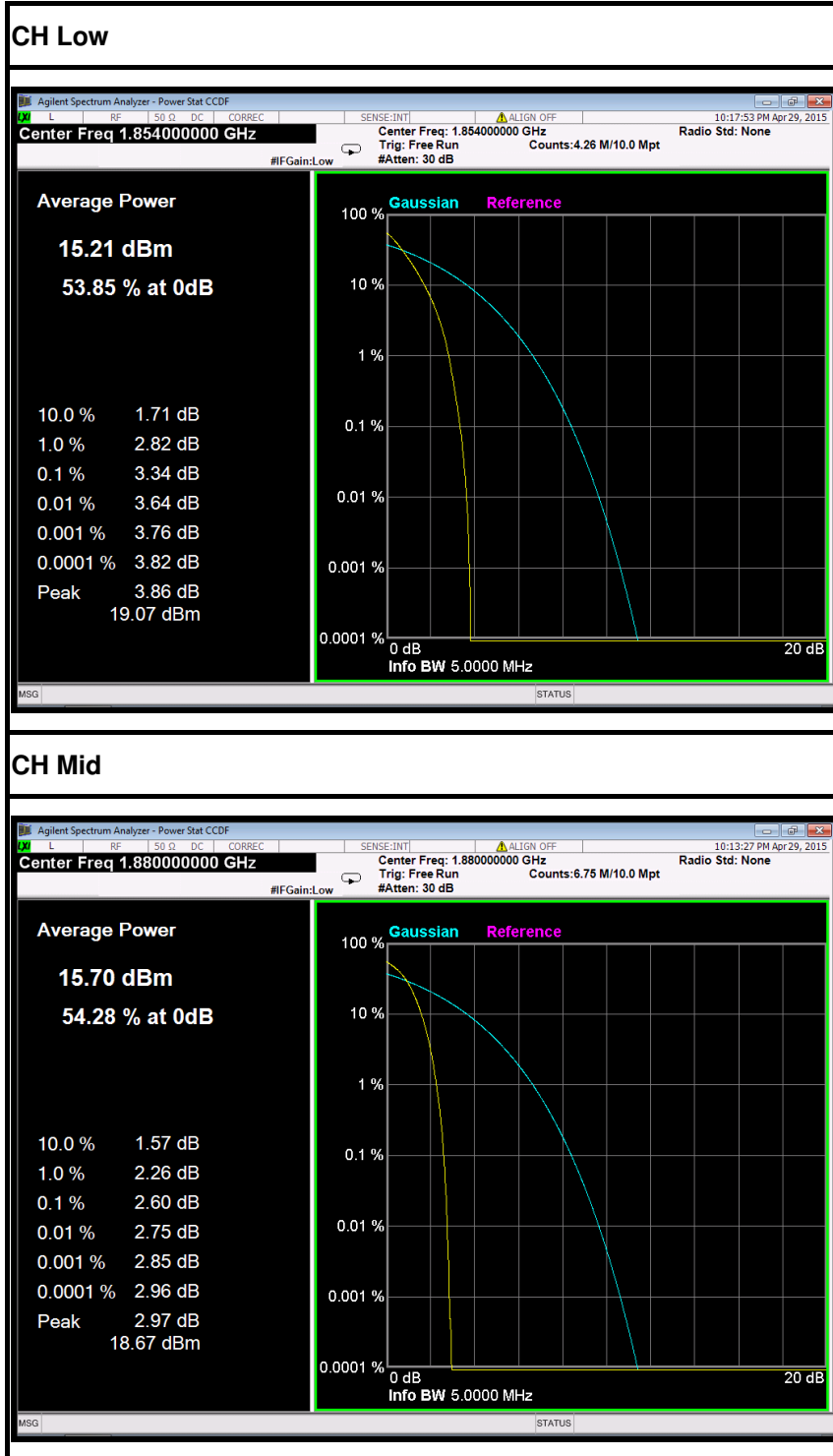

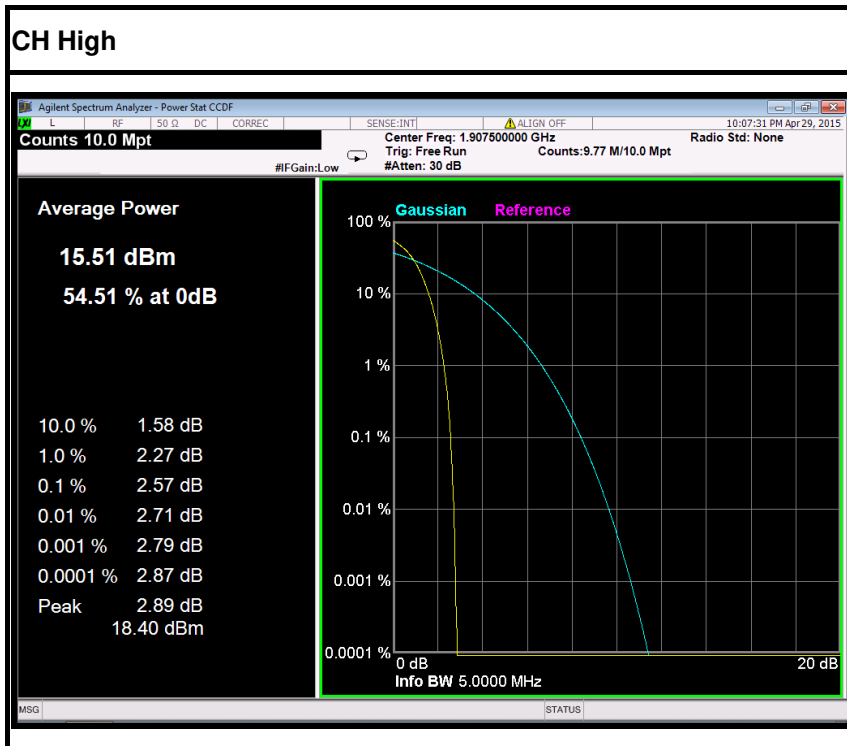



6.4 ERP & EIRP MEASUREMENT

6.4.1 LIMIT

According to FCC §2.1046

FCC 22.913(a): The Effective Radiated Power (ERP) of mobile transmitters must not exceed 7 Watts.

FCC 24.232(b): The equivalent Isotropic Radiated Power (EIRP) must not exceed 2 Watts.

6.4.2 MEASUREMENT EQUIPMENT USED

Name of Equipment	Manufacturer	Model Number	Serial Number	Last Calibration	Due Calibration
Spectrum Analyzer	Agilent	E4446A	US44300399	02/21/2016	02/20/2017
Spectrum Analyzer	Agilent	N9010A	MY52221469	02/21/2016	02/20/2017
Signal Generator	Anritsu	MG3694A	#050125	02/28/2016	02/27/2017
Bi-log Antenna	SCHAFFNER	CBL6143	5063	02/21/2016	02/20/2017
Turn Table	N/A	N/A	N/A	N.C.R	N.C.R
Controller	Sunol Sciences	SC104V	022310-1	N.C.R	N.C.R
Controller	CT	N/A	N/A	N.C.R	N.C.R
Temp. / Humidity Meter	Anymetre	JR913	N/A	02/21/2016	02/20/2017
Antenna Tower	SUNOL	TLT2	N/A	N.C.R	N.C.R
Test S/W	FARAD	LZ-RF / CCS-SZ-3A2			

Remark: Each piece of equipment is scheduled for calibration once a year.

6.4.3 TEST CONFIGURATION

Below 1 GHz

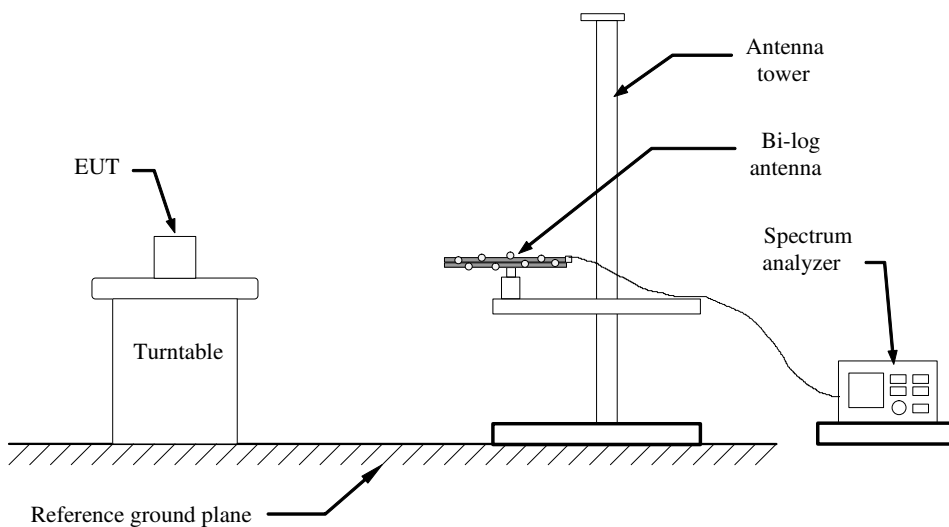



Above 1 GHz

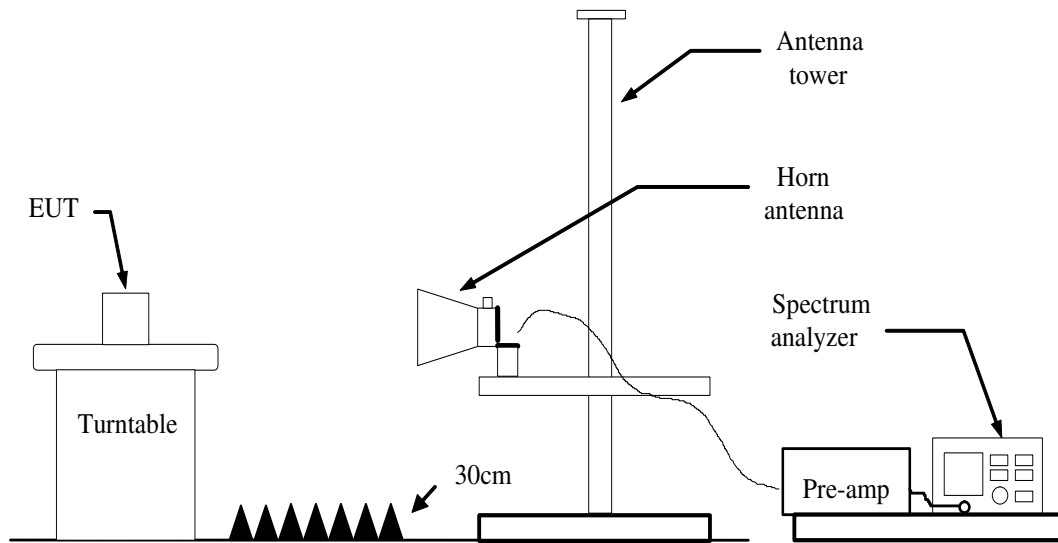

Substituted Method Test Set-up

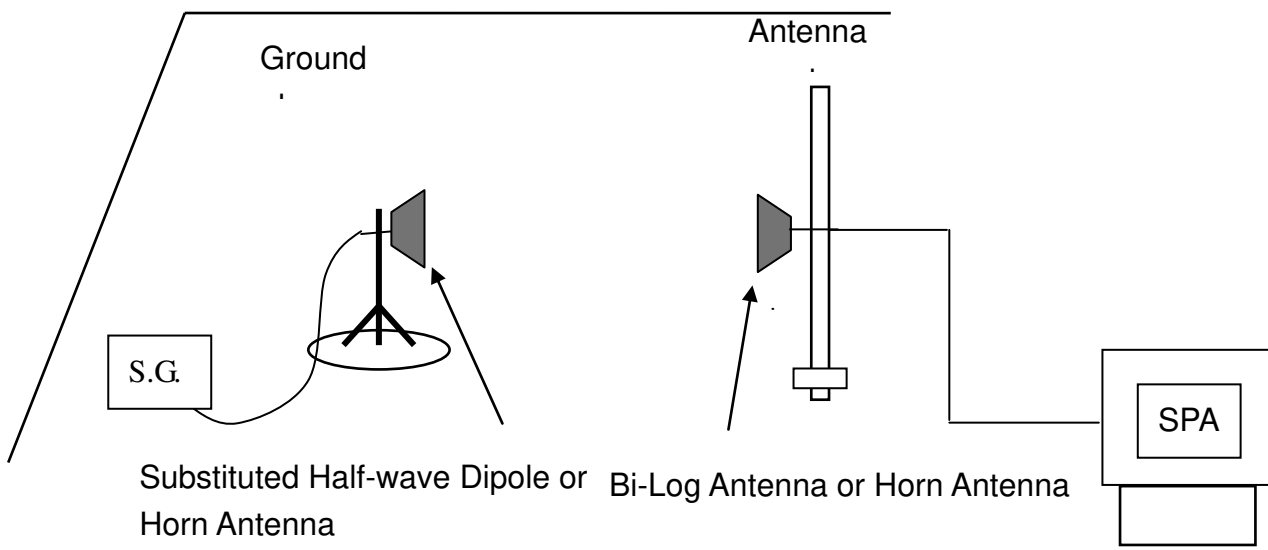

For the actual test configuration, please refer to the related item – Photographs of the test configuration.



6.4.4 TEST PROCEDURE

The EUT was placed on a non-conductive turntable using a non-conductive support. The radiated emission at the fundamental frequency was measured at 3 m with a test antenna and EMI spectrum analyzer.

During the measurement of the EUT, the resolution bandwidth was set to 5MHz and the average bandwidth was set to 50MHz. The highest emission was recorded with the rotation of the turntable and the lowering of the test antenna. The reading was recorded and the field strength (E in dBuV/m) was calculated.

ERP in frequency band 824-849MHz, and EIRP in frequency band 1851.25 –1910MHz were measured using a substitution method. The EUT was replaced by half-wave dipole (824-849MHz) or horn antenna (1851.25-1910MHz) connected to a signal generator. The spectrum analyzer reading was recorded and ERP/EIRP was calculated as follows:

$$\text{ERP} = \text{S.G. output (dBm)} + \text{Antenna Gain (dBi)} - \text{Cable (dB)} - 2.15$$

$$\text{EIRP} = \text{S.G. output (dBm)} + \text{Antenna Gain (dBi)} - \text{Cable (dB)}$$

6.4.5 TEST RESULTS

No non-compliance noted.



HSDPA BAND II Test Data

Channel	Frequency (MHz)	Antenna Pol.	S.G. (dBm)	Cable loss (dB)	Ant.Gain (dBi)	EIRP (dBm)	Limit (dBm)	Margin (dB)
9262	1852.40	V	30.02	-3.66	9.1	24.58	33.00	-8.42
	1852.40	H	22.93	-3.66	9.1	17.49	33.00	-15.51
9400	1880.00	V	28.60	-3.66	9.1	23.16	33.00	-9.84
	1880.00	H	22.73	-3.66	9.1	17.29	33.00	-15.71
9538	1907.60	V	28.39	-3.66	9.1	22.95	33.00	-10.05
	1907.60	H	22.87	-3.66	9.1	17.43	33.00	-15.57



6.4.6 OCCUPIED BANDWIDTH MEASUREMENT AND EMISSION BANDWIDTH MEASUREMENT

6.4.7 LIMIT

According to §FCC 2.1049.

6.4.8 MEASUREMENT EQUIPMENT USED

Name of Equipment	Manufacturer	Model	Serial Number	Last Calibration	Due Calibration
Spectrum Analyzer	Agilent	N9010A	MY52221469	10/25/2014	10/24/2015
Universal Radio Communication Tester	Agilent	8960	MY48367671	09/04/2014	09/03/2015

Remark: Each piece of equipment is scheduled for calibration once a year.

6.4.9 TEST CONFIGURATION

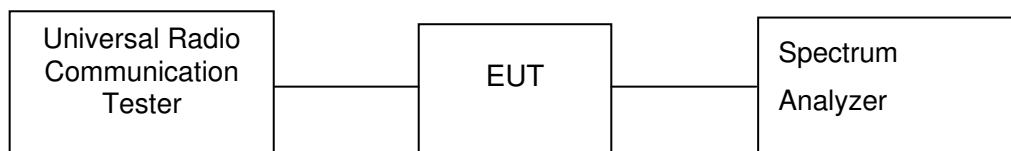

Remark: Measurement setup for testing on Antenna connector

6.4.10 TEST PROCEDURE

The EUT's output RF connector was connected with a short cable to the spectrum analyzer, RBW was set to about 1% of emission BW, VBW is set to 3 times the RBW, -26dBc display line was placed on the screen (or 99% bandwidth), the occupied bandwidth is the delta frequency between the two points where the display line intersects the signal trace.

6.4.11 TEST RESULTS

No non-compliance noted



Test Data

Test Mode	CH	Frequency (MHz)	99% Bandwidth (MHz)
HSDPA (BAND II)	9262	1852.40	4.0674
	9400	1880.00	4.0702
	9538	1907.60	4.0669

Test Mode	CH	Frequency (MHz)	26dB Bandwidth (MHz)
HSDPA (BAND II)	9262	1852.40	4.6490
	9400	1880.00	4.6750
	9538	1907.60	4.6480



Test Plot

HSDPA Band II (CH Low)

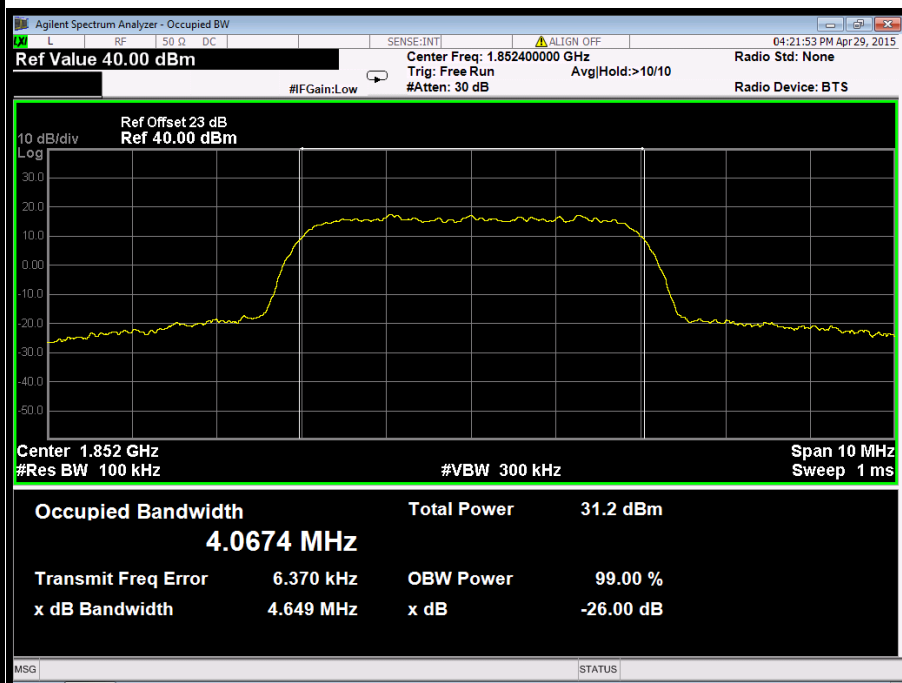

HSDPA Band II (CH Mid)

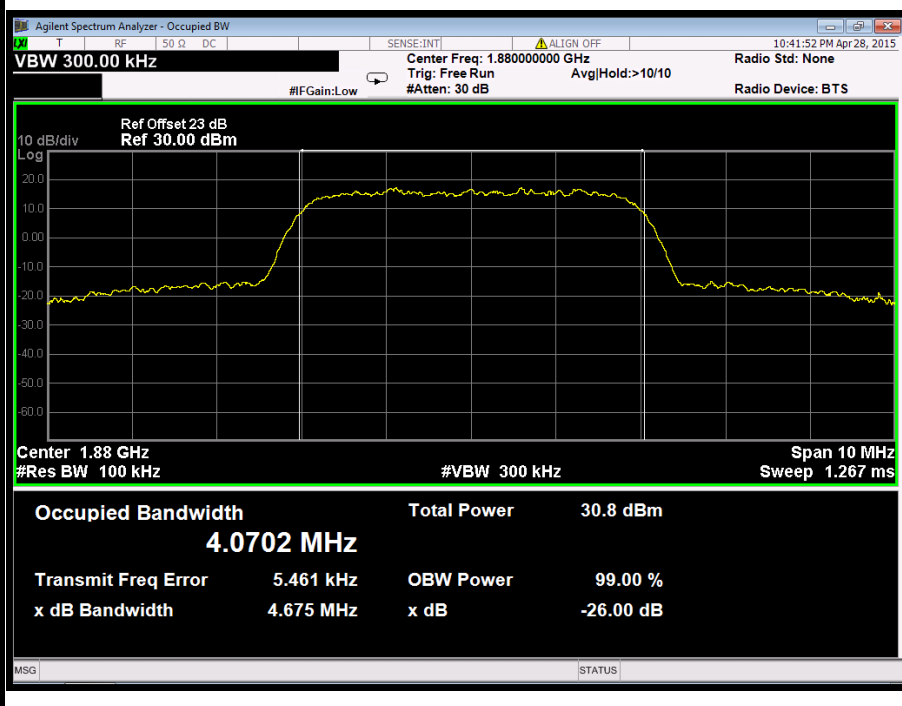



HSDPA Band II (CH High)

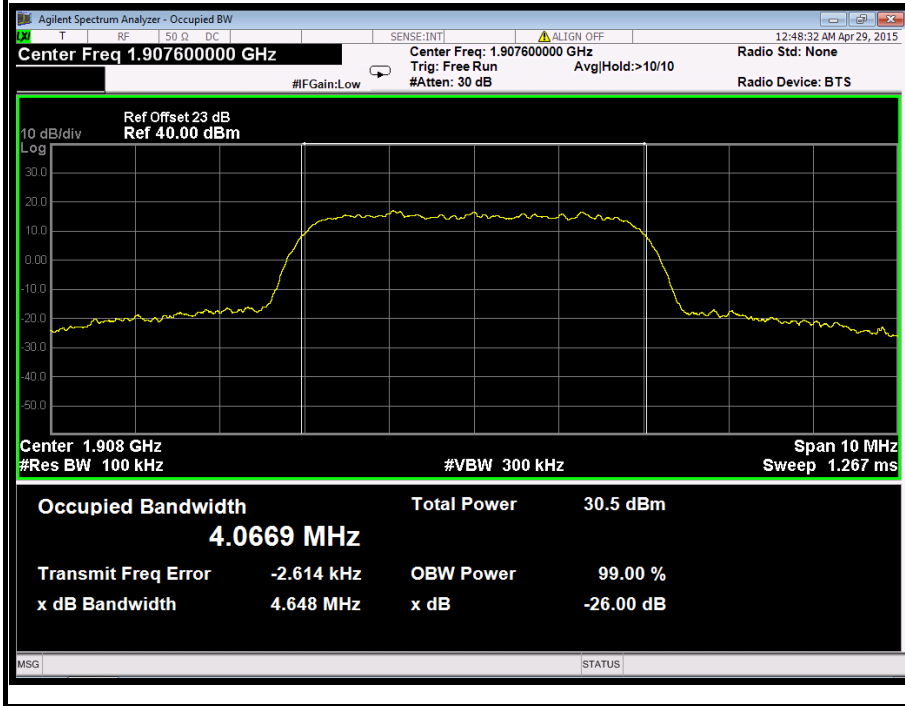



6.5 OUT OF BAND EMISSION AT ANTENNA TERMINALS

6.5.1 LIMIT

According to FCC §2.1051, FCC §22.917, FCC §24.238(a).

Out of Band Emissions: The mean power of emission must be attenuated below the mean power of the non-modulated carrier (P) on any frequency twice or more than twice the fundamental frequency by at least $43 + 10 \log P$ dB.

Mobile Emissions in Base Frequency Range: The mean power of any emissions appearing in the base station frequency range from cellular mobile transmitters operated must be attenuated to a level not exceed -80 dBm at the transmit antenna connector.

Band Edge Requirements: In the 1MHz bands immediately outside and adjacent to the frequency block, a resolution bandwidth of at least 1% of the emission bandwidth of the fundamental emission of the transmitter may be employed to measure the Out of band Emission

6.5.2 MEASUREMENT EQUIPMENT USED

Name of Equipment	Manufacturer	Model	Serial Number	Last Calibration	Due Calibration
Spectrum Analyzer	Agilent	N9010A	MY52221469	10/25/2014	10/24/2015
Universal Radio Communication Tester	Agilent	8960	MY48367671	09/04/2014	09/03/2015

Remark: Each piece of equipment is scheduled for calibration once a year.

6.5.3 TEST CONFIGURATION





6.5.4 TEST PROCEDURE

The RF output of the transceiver was connected to a spectrum analyzer through appropriate attenuation. The resolution bandwidth of the spectrum analyzer was set at 1MHz, sufficient scans were taken to show the out of band Emissions if any up to 10th harmonic.

For the out of band: Set the RBW, VBW = 1MHz, Start=9kHz, Stop= 10 th harmonic. Limit = -13dBm

Band Edge Requirements (824 MHz and 849 MHz /1850MHz and 1910MHz): In the 1 MHz bands immediately outside and adjacent to the frequency block, a resolution bandwidth of at least 1 percent of the emission bandwidth of the fundamental emission of the transmitter may be employed to measure the out of band Emissions. Limit, -13dBm.

6.5.5 TEST RESULTS

No non-compliance noted.



Test Data

Mode	CH	Location	Description
HSDPA (Band II)	9262	Figure 1-1	Conducted spurious emissions, 9kHz – 30MHz
		Figure 1-2	Conducted spurious emissions, 30MHz - 1GHz
		Figure 1-3	Conducted spurious emissions, 1GHz - 5GHz
		Figure 1-4	Conducted spurious emissions, 5GHz - 10GHz
		Figure 1-5	Conducted spurious emissions, 10GHz - 20GHz
	9400	Figure 2-1	Conducted spurious emissions, 9kHz – 30MHz
		Figure 2-2	Conducted spurious emissions, 30MHz - 1GHz
		Figure 2-3	Conducted spurious emissions, 1GHz - 5GHz
		Figure 2-4	Conducted spurious emissions, 5GHz - 10GHz
		Figure 2-5	Conducted spurious emissions, 10GHz - 20GHz
	9538	Figure 3-1	Conducted spurious emissions, 9kHz – 30MHz
		Figure 3-2	Conducted spurious emissions, 30MHz - 1GHz
		Figure 3-3	Conducted spurious emissions, 1GHz - 5GHz
		Figure 3-4	Conducted spurious emissions, 5GHz - 10GHz
		Figure 3-5	Conducted spurious emissions, 10GHz - 20GHz

Mode	CH	Location	Description
HSDPA (Band II)	9262	Figure 4-1	Band Edge emissions
	9538	Figure 4-2	Band Edge emissions



Test Plot

HSDPA Band II

Figure 1-1: Out of Band emission at antenna terminals – HSDPA CH Low

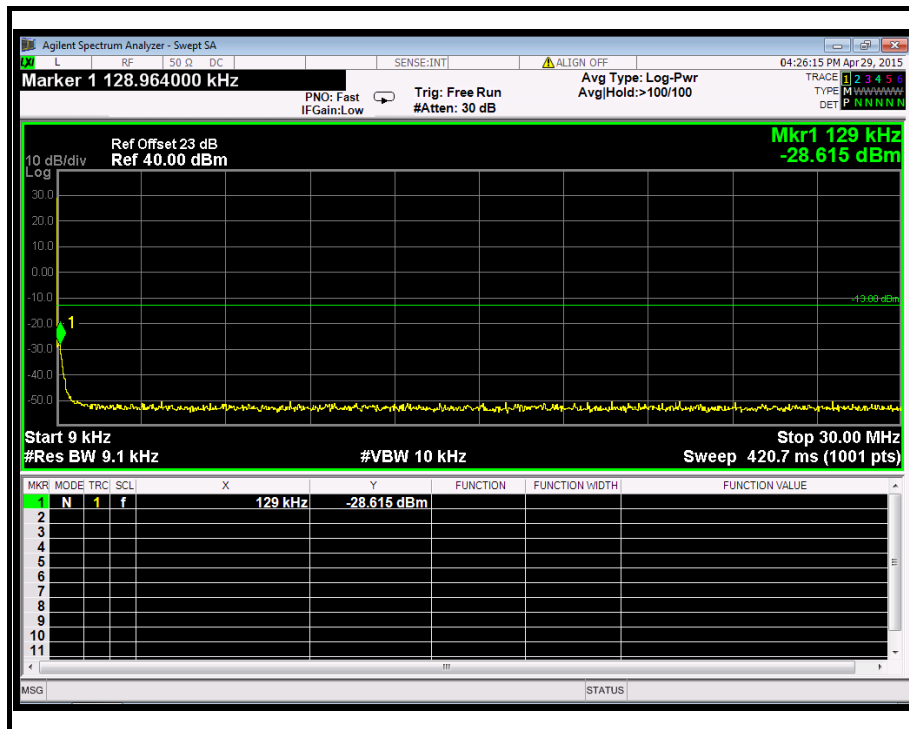

Figure 1-2: Out of Band emission at antenna terminals – HSDPA CH Low

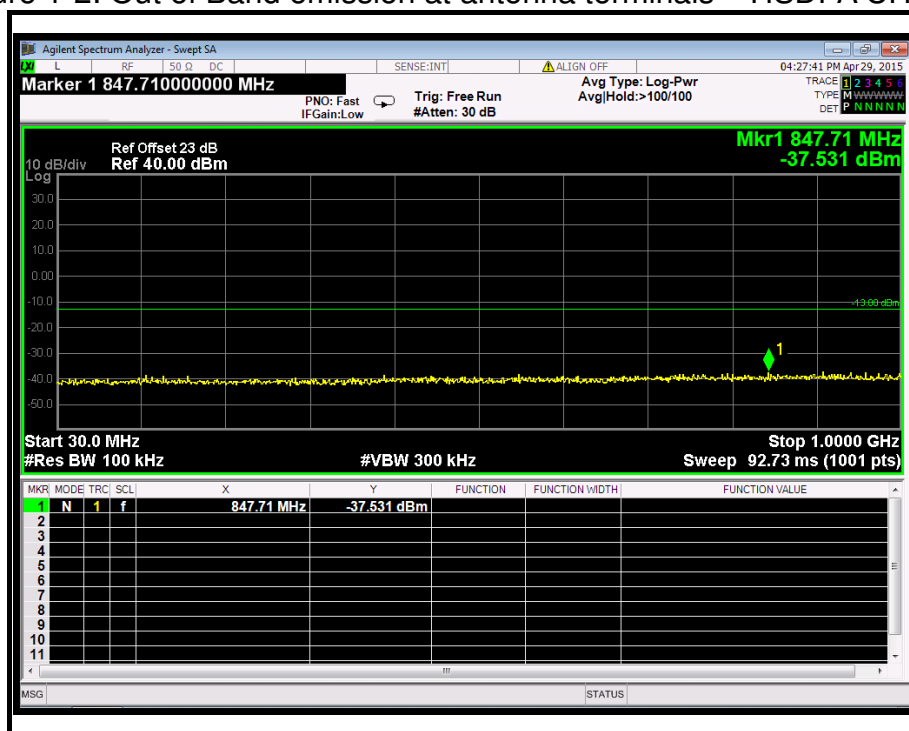



Figure 1-3: Out of Band emission at antenna terminals – HSDPA CH Low

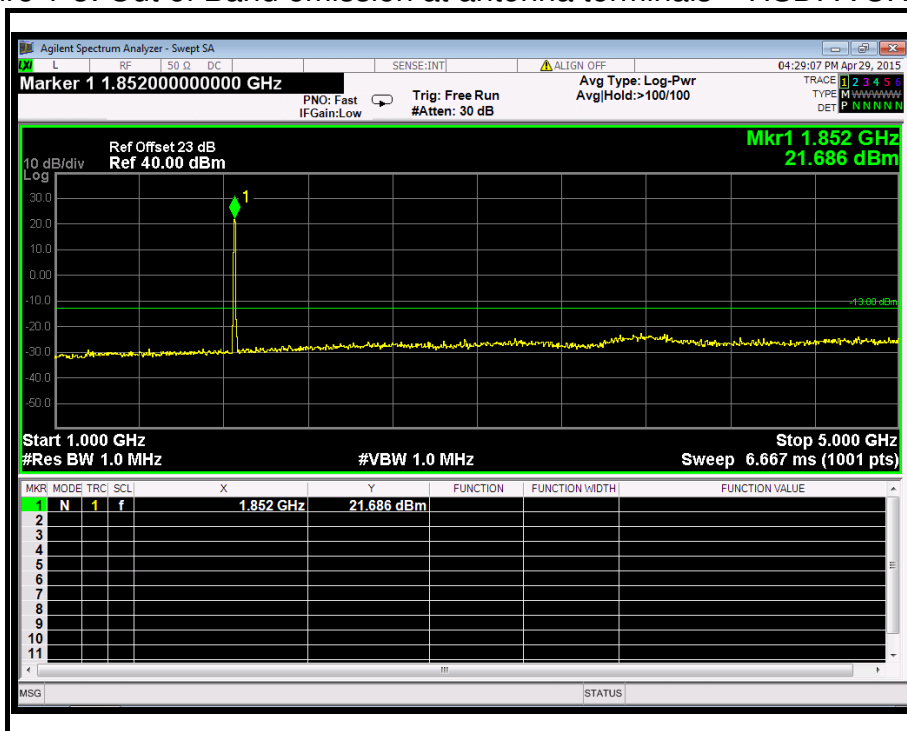

Figure 1-4: Out of Band emission at antenna terminals – HSDPA CH Low

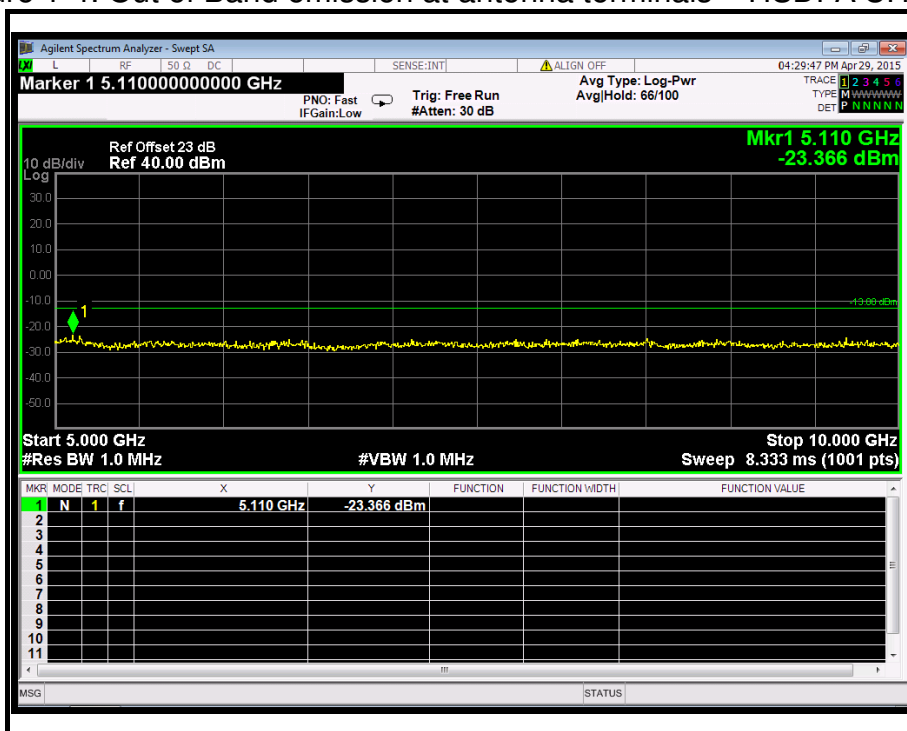



Figure 1-5: Out of Band emission at antenna terminals – HSDPA CH Low

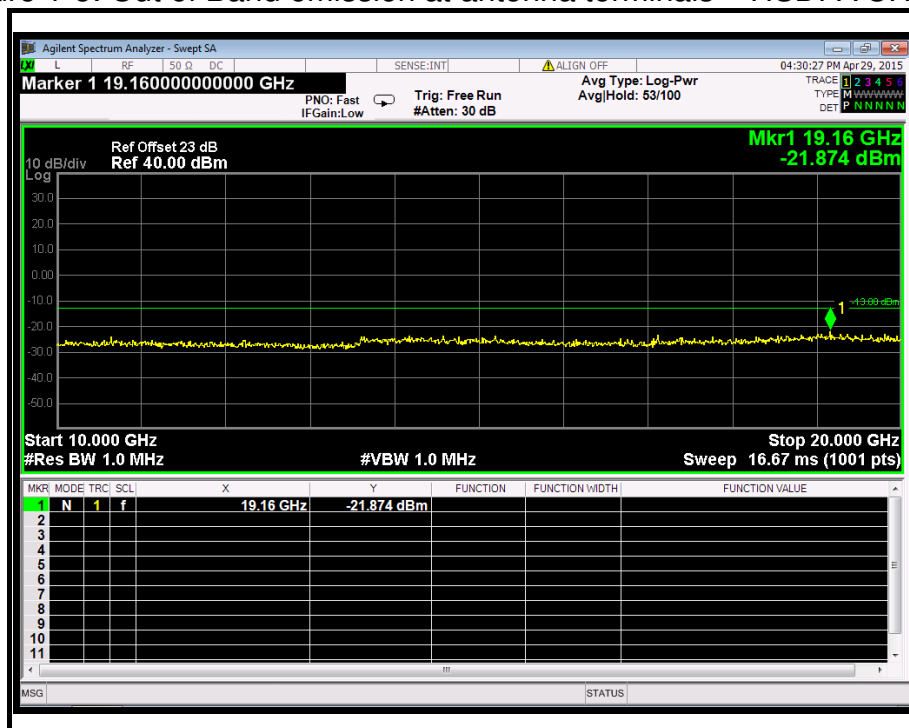



Figure 2-1: Out of Band emission at antenna terminals – HSDPA CH Mid

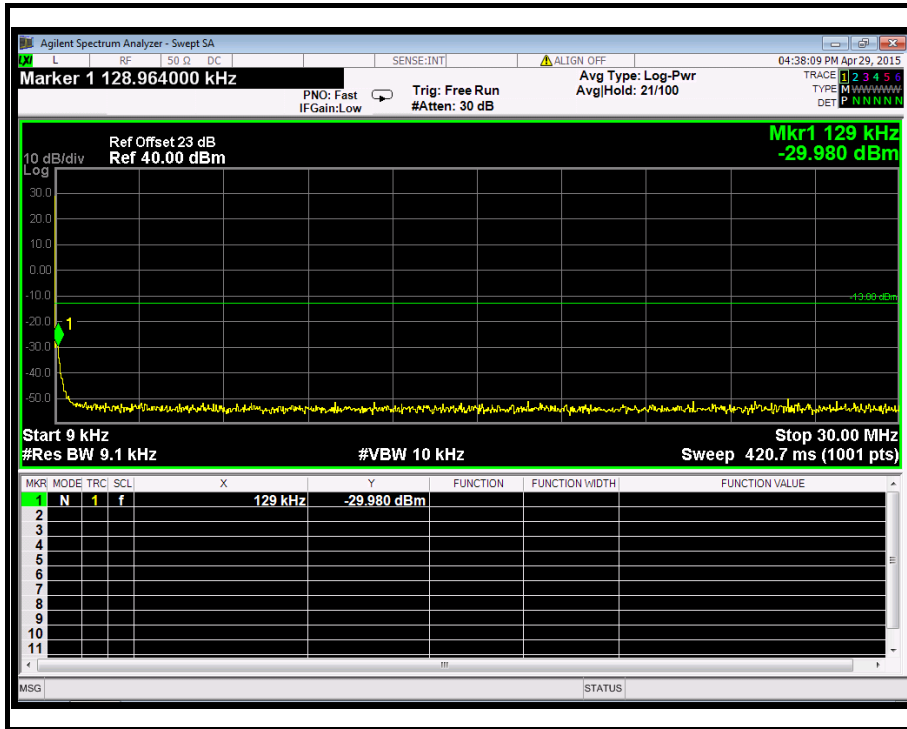

Figure 2-2: Out of Band emission at antenna terminals – HSDPA CH Mid

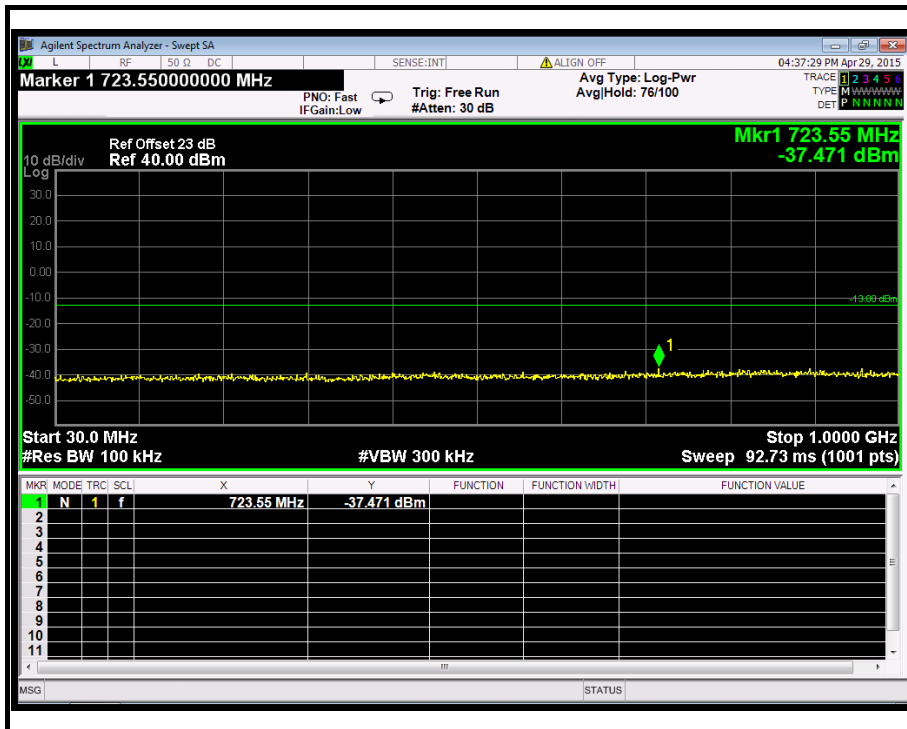



Figure 2-3: Out of Band emission at antenna terminals – HSDPA CH Mid

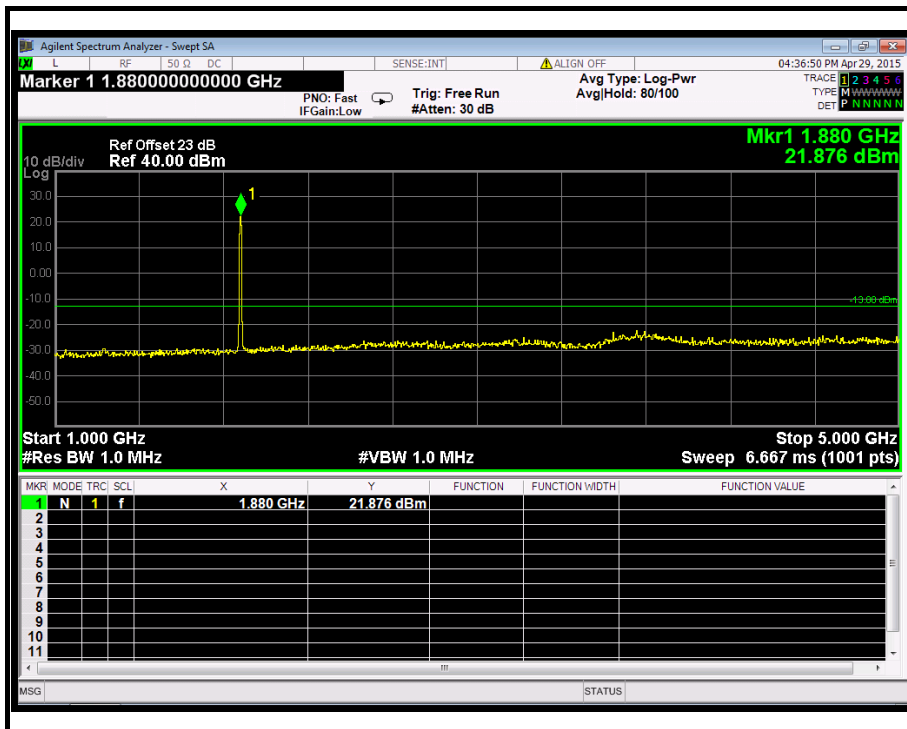

Figure 2-4: Out of Band emission at antenna terminals – HSDPA CH Mid

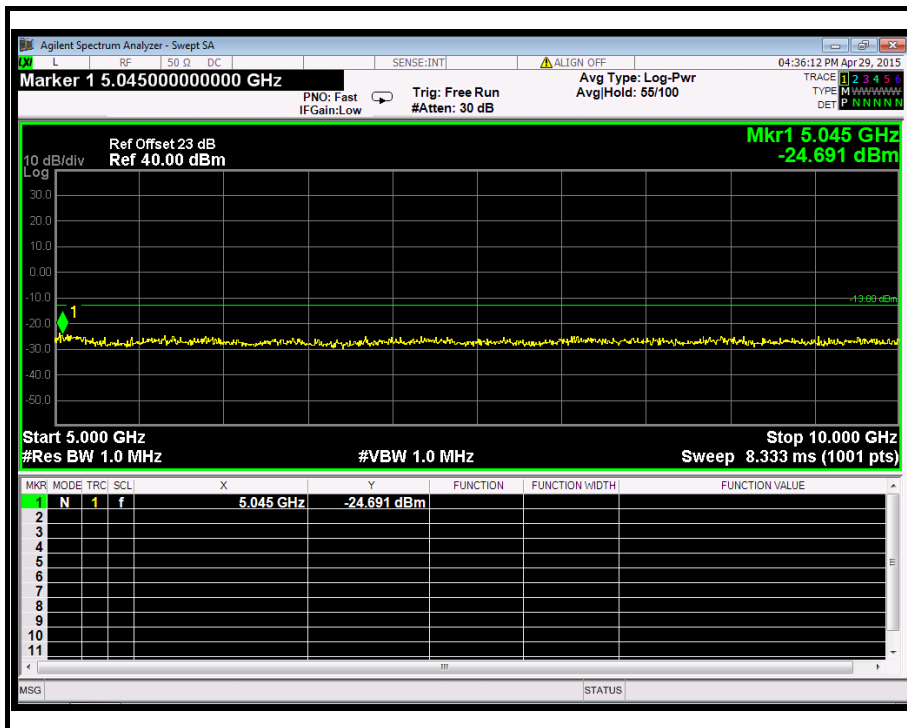



Figure 2-5: Out of Band emission at antenna terminals – HSDPA CH Mid

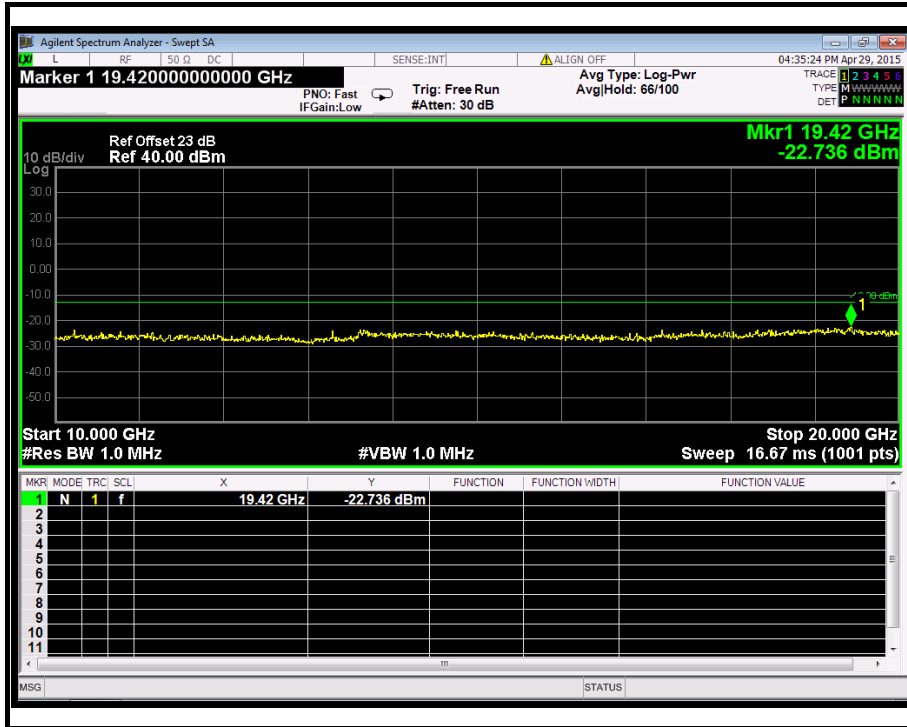



Figure 3-1: Out of Band emission at antenna terminals – HSDPA CH High

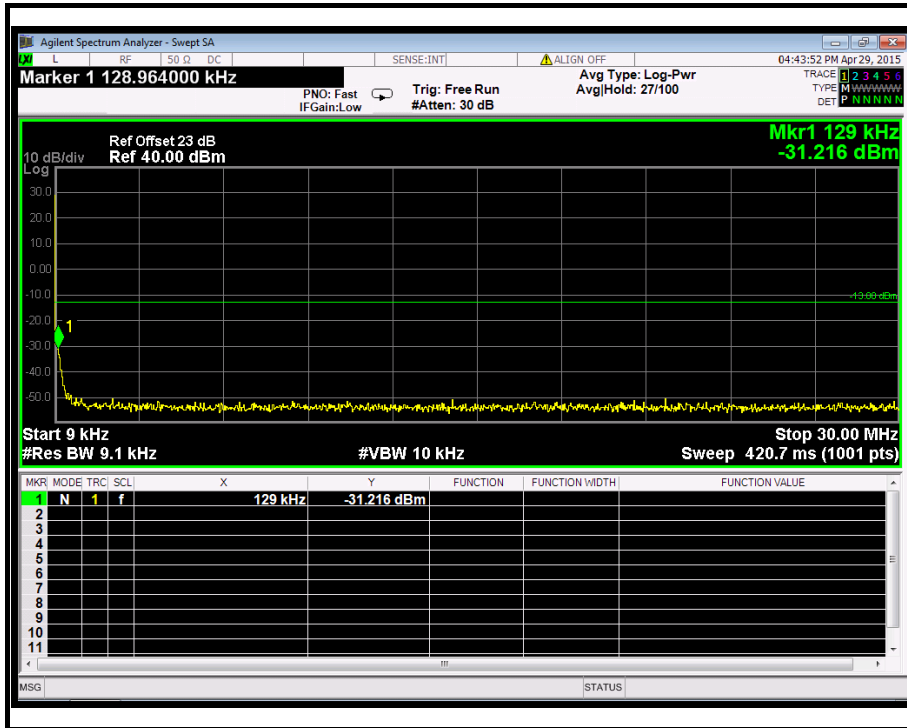

Figure 3-2: Out of Band emission at antenna terminals – HSDPA CH High

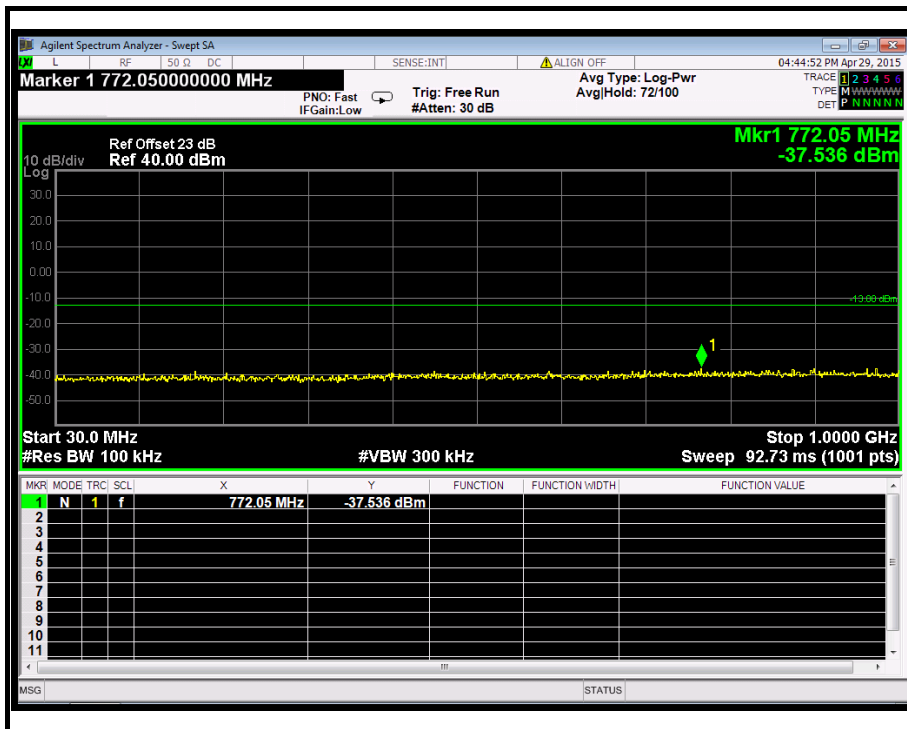



Figure 3-3: Out of Band emission at antenna terminals – HSDPA CH High

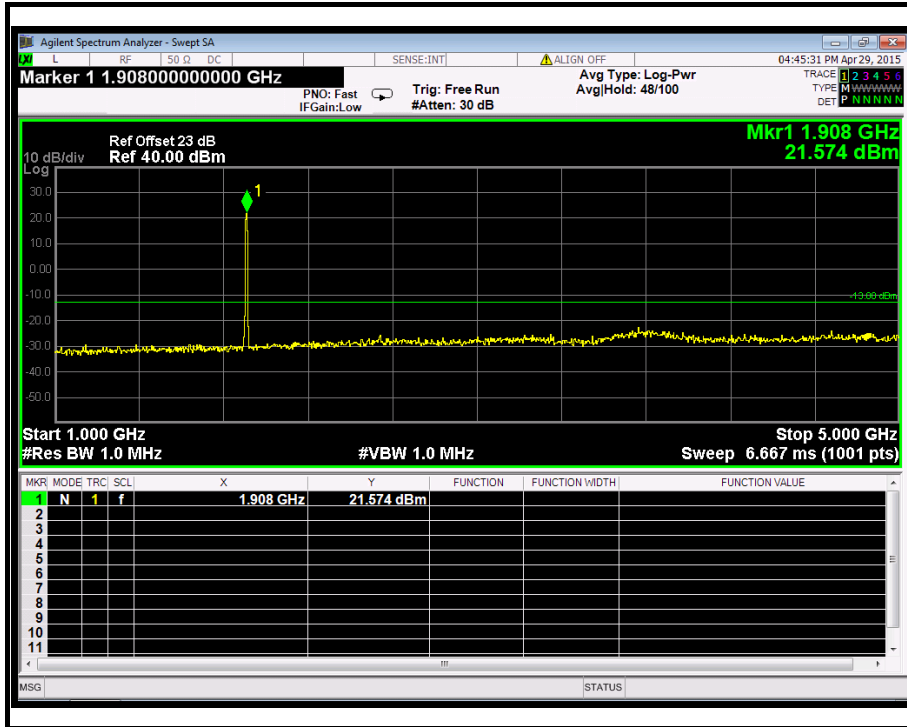

Figure 3-4: Out of Band emission at antenna terminals – HSDPA CH High

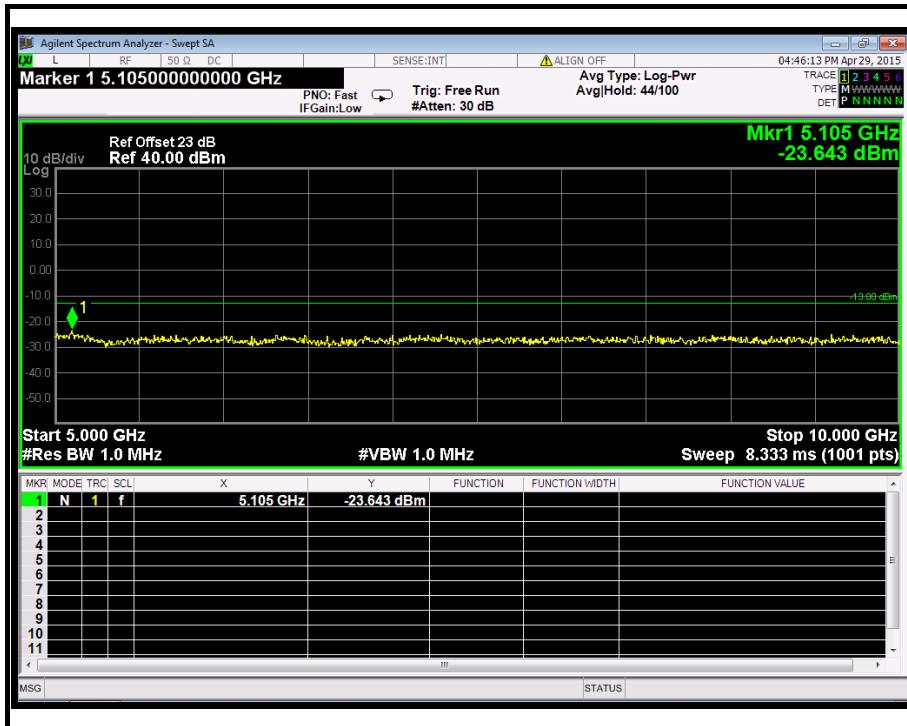
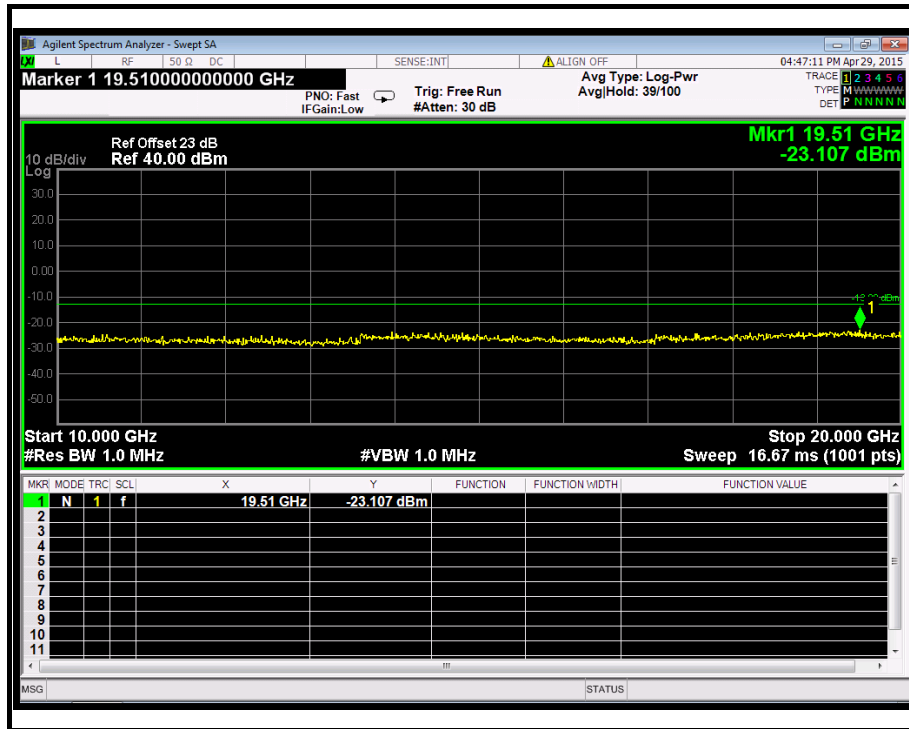



Figure 3-5: Out of Band emission at antenna terminals – HSDPA CH High





HSDPA Band II

Figure 4-1: Band Edge emissions – HSDPA CH Low

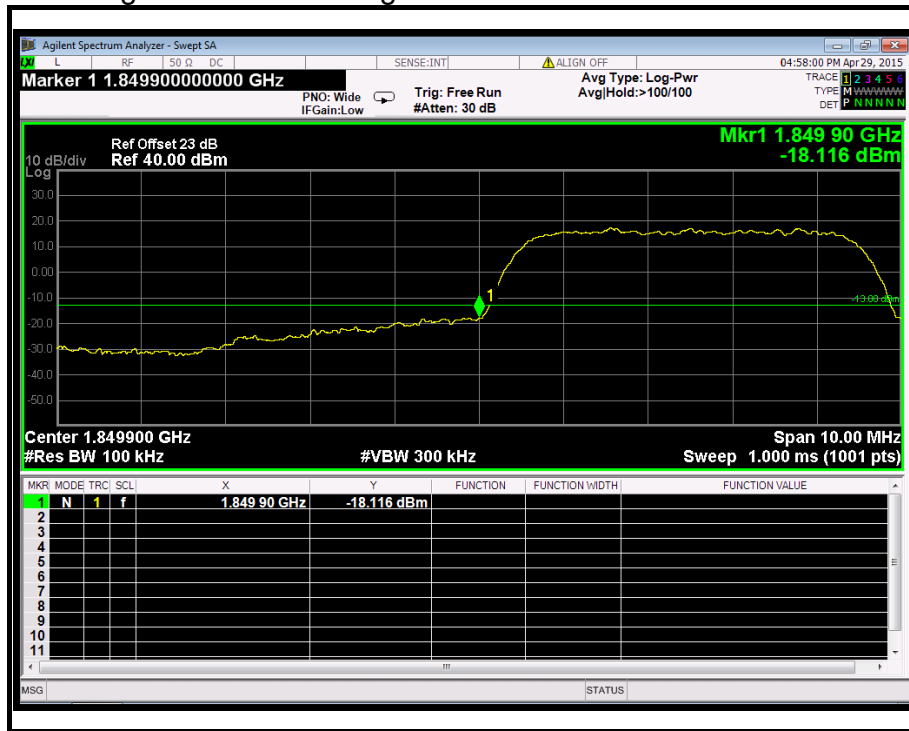
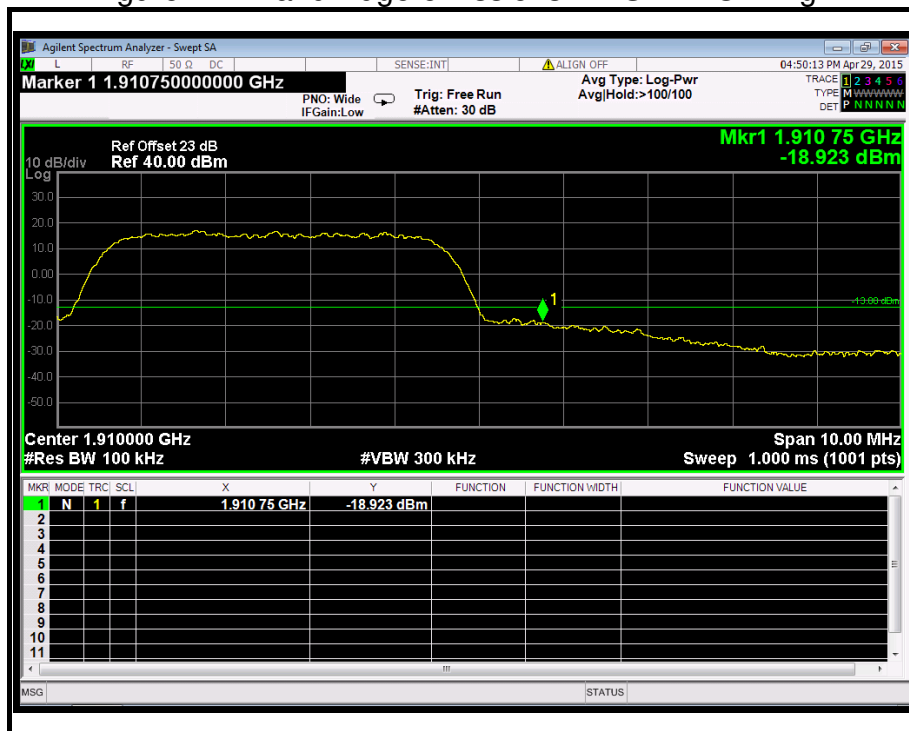

Figure 4-2: Band Edge emissions – HSDPA CH High





6.6 FIELD STRENGTH OF SPURIOUS RADIATION MEASUREMENT

6.6.1 LIMIT

According to FCC §2.1053

6.6.2 MEASUREMENT EQUIPMENT USED

Name of Equipment	Manufacturer	Model Number	Serial Number	Last Calibration	Due Calibration
Spectrum Analyzer	Agilent	E4446A	US44300399	02/21/2016	02/20/2017
Spectrum Analyzer	Agilent	N9010A	MY52221469	02/21/2016	02/20/2017
Signal Generator	Anritsu	MG3694A	#050125	02/28/2016	02/27/2017
Bi-log Antenna	SCHAFFNER	CBL6143	5063	02/21/2016	02/20/2017
Turn Table	N/A	N/A	N/A	N.C.R	N.C.R
Controller	Sunol Sciences	SC104V	022310-1	N.C.R	N.C.R
Controller	CT	N/A	N/A	N.C.R	N.C.R
Temp. / Humidity Meter	Anymetre	JR913	N/A	02/21/2016	02/20/2017
Antenna Tower	SUNOL	TLT2	N/A	N.C.R	N.C.R
Test S/W	FARAD	LZ-RF / CCS-SZ-3A2			

Remark: Each piece of equipment is scheduled for calibration once a year.

6.6.3 TEST CONFIGURATION

Below 1 GHz

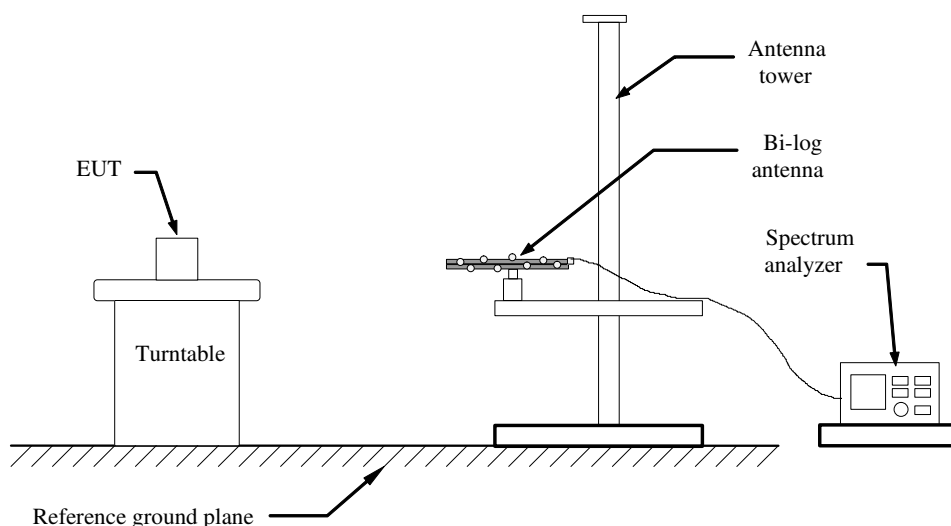



Above 1 GHz

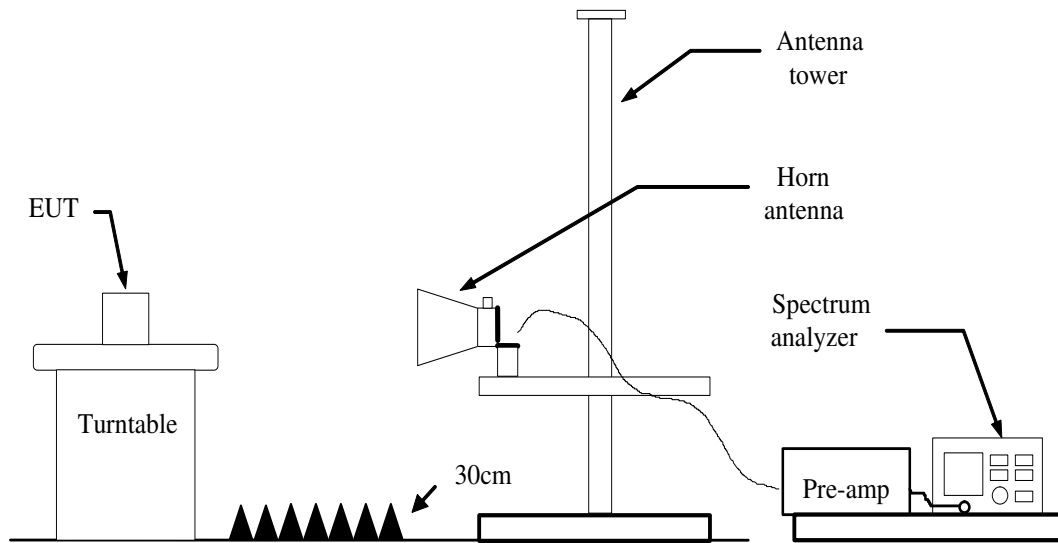

Substituted Method Test Set-up

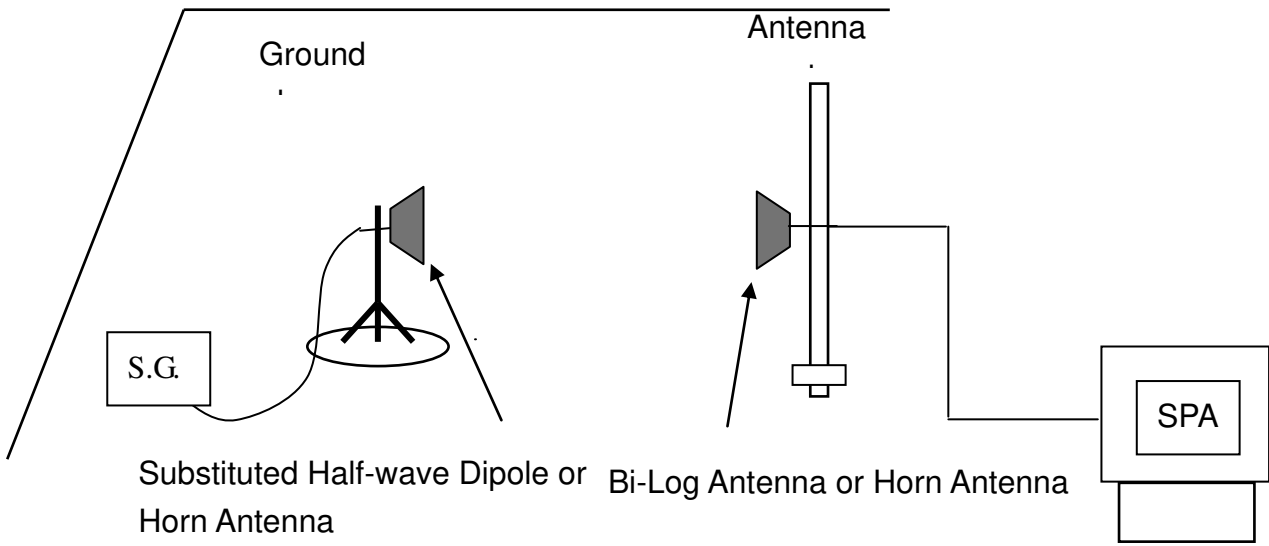



6.6.4 TEST PROCEDURE

The EUT was placed on a non-conductive, the measurement antenna was placed at a distance of 3 meters from the EUT. During the tests, the antenna height and the EUT azimuth were varied in order to identify the maximum level of emissions from the EUT. This maximization process was repeated with the EUT positioned in each of its three orthogonal orientations.

The frequency range up to tenth harmonic was investigated for each of three fundamental frequency (low, middle and high channels). Once spurious emission were identified, the power of the emission was determined using the substitution method.

The spurious emissions attenuation was calculated as the difference between radiated power at the fundamental frequency and the spurious emissions frequency.

$ERP = \text{S.G. output (dBm)} + \text{Antenna Gain (dBd)} - \text{Cable (dB)}$

$EIRP = \text{S.G. output (dBm)} + \text{Antenna Gain (dBi)} - \text{Cable (dB)}$

6.6.5 TEST RESULTS

Refer to the attached tabular data sheets.



Radiated Spurious Emission Measurement Result / Below 1GHz

Operation Mode:	HSDPA Band II / TX / CH 9262	Test Date:	October 16, 2016
Temperature:	25°C	Tested by:	Eve Wang
Humidity:	55 % RH	Polarity:	Ver. / Hor.

Frequency (MHz)	Reading (dBm)	Correction Factor (dB)	Result (dBm)	Limit (dBm)	Margin (dB)	Antenna Pole (V/H)	Remark
50.3700	-67.61	3.45	-64.16	-13.00	-51.16	V	Peak
111.4800	-65.95	1.11	-64.84	-13.00	-51.84	V	Peak
245.3400	-54.53	-3.66	-58.19	-13.00	-45.19	V	Peak
468.4400	-67.47	1.71	-65.76	-13.00	-52.76	V	Peak
623.6400	-65.20	4.08	-61.12	-13.00	-48.12	V	Peak
684.7500	-65.28	5.99	-59.29	-13.00	-46.29	V	Peak
58.1300	-65.26	1.76	-63.50	-13.00	-50.50	H	Peak
129.9100	-68.36	5.90	-62.46	-13.00	-49.46	H	Peak
245.3400	-54.23	-3.85	-58.08	-13.00	-45.08	H	Peak
623.6400	-64.62	4.28	-60.34	-13.00	-47.34	H	Peak
672.1400	-65.75	5.52	-60.23	-13.00	-47.23	H	Peak
815.7000	-63.70	8.10	-55.60	-13.00	-42.60	H	Peak

Remark:

1. The emission behaviour belongs to narrowband spurious emission.
2. Measurements above show only up to 6 maximum emissions noted, or would be lesser, with " N/A " remark, if no specific emissions from the EUT are recorded (ie: margin>20dB from the applicable limit) and considered that's already beyond the background noise floor.



Operation Mode:	HSDPA Band II / TX / CH 9400	Test Date:	October 16, 2016
Temperature:	25°C	Tested by:	Eve Wang
Humidity:	55 % RH	Polarity:	Ver. / Hor.

Frequency (MHz)	Reading (dBm)	Correction Factor (dB)	Result (dBm)	Limit (dBm)	Margin (dB)	Antenna Pole (V/H)	Remark
50.3700	-67.49	3.45	-64.04	-13.00	-51.04	V	Peak
112.4500	-66.01	1.46	-64.55	-13.00	-51.55	V	Peak
400.5400	-67.47	0.34	-67.13	-13.00	-54.13	V	Peak
542.1600	-67.93	3.30	-64.63	-13.00	-51.63	V	Peak
592.6000	-68.37	4.32	-64.05	-13.00	-51.05	V	Peak
751.6800	-68.17	7.38	-60.79	-13.00	-47.79	V	Peak
57.1600	-66.63	2.60	-64.03	-13.00	-51.03	H	Peak
128.9400	-66.95	3.58	-63.37	-13.00	-50.37	H	Peak
438.3700	-67.68	1.29	-66.39	-13.00	-53.39	H	Peak
497.5400	-68.29	2.39	-65.90	-13.00	-52.90	H	Peak
631.4000	-67.31	4.43	-62.88	-13.00	-49.88	H	Peak
762.3500	-68.25	6.97	-61.28	-13.00	-48.28	H	Peak

Remark:

- 3. *The emission behaviour belongs to narrowband spurious emission.*
- 4. *Measurements above show only up to 6 maximum emissions noted, or would be lesser, with " N/A " remark, if no specific emissions from the EUT are recorded (ie: margin>20dB from the applicable limit) and considered that's already beyond the background noise floor.*



Operation Mode:	HSDPA Band II / TX / CH 9538	Test Date:	October 16, 2016
Temperature:	25°C	Tested by:	Eve Wang
Humidity:	55 % RH	Polarity:	Ver. / Hor.

Frequency (MHz)	Reading (dBm)	Correction Factor (dB)	Result (dBm)	Limit (dBm)	Margin (dB)	Antenna Pole (V/H)	Remark
49.4000	-66.65	2.29	-64.36	-13.00	-51.36	V	Peak
111.4800	-66.34	1.11	-65.23	-13.00	-52.23	V	Peak
246.3100	-55.36	-3.79	-59.15	-13.00	-46.15	V	Peak
366.5900	-63.67	-1.31	-64.98	-13.00	-51.98	V	Peak
576.1100	-65.77	3.73	-62.04	-13.00	-49.04	V	Peak
623.6400	-64.77	4.08	-60.69	-13.00	-47.69	V	Peak
57.1600	-65.93	2.60	-63.33	-13.00	-50.33	H	Peak
132.8200	-66.84	4.39	-62.45	-13.00	-49.45	H	Peak
250.1900	-55.04	-3.98	-59.02	-13.00	-46.02	H	Peak
672.1400	-63.14	5.52	-57.62	-13.00	-44.62	H	Peak
719.6700	-60.66	6.09	-54.57	-13.00	-41.57	H	Peak
768.1700	-59.57	6.95	-52.62	-13.00	-39.62	H	Peak

Remark:

1. The emission behaviour belongs to narrowband spurious emission.
2. Measurements above show only up to 6 maximum emissions noted, or would be lesser, with " N/A " remark, if no specific emissions from the EUT are recorded (ie: margin>20dB from the applicable limit) and considered that's already beyond the background noise floor.



Above 1GHz

Operation Mode:	HSDPA Band II / TX / CH 9262	Test Date:	October 14, 2016
Temperature:	25°C	Tested by:	Eve Wang
Humidity:	55 % RH	Polarity:	Ver. / Hor.

Frequency (MHz)	Reading (dBm)	Correction Factor (dB)	Result (dBm)	Limit (dBm)	Margin (dB)	Antenna Pole (V/H)	Remark
1440.000	-48.05	-6.37	-54.42	-13.00	-41.42	V	Peak
2140.000	-35.97	-3.15	-39.12	-13.00	-26.12	V	Peak
2592.000	-58.23	-3.19	-61.42	-13.00	-48.42	V	Peak
2880.000	-60.69	-2.09	-62.78	-13.00	-49.78	V	Peak
3452.000	-62.69	0.46	-62.23	-13.00	-49.23	V	Peak
3976.000	-62.83	1.46	-61.37	-13.00	-48.37	V	Peak
1488.000	-43.44	-5.66	-49.10	-13.00	-36.10	H	Peak
2140.000	-39.72	-3.07	-42.79	-13.00	-29.79	H	Peak
2400.000	-56.04	-3.18	-59.22	-13.00	-46.22	H	Peak
2880.000	-57.87	-1.94	-59.81	-13.00	-46.81	H	Peak
4568.000	-62.77	3.91	-58.86	-13.00	-45.86	H	Peak
9365.000	-65.32	11.06	-54.26	-13.00	-41.26	H	Peak

Remark:

1. Measuring frequencies from 1 GHz to the 10th harmonic of highest fundamental frequency.
2. Measurements above show only up to 6 maximum emissions noted, or would be lesser, with " N/A " remark, if no specific emissions from the EUT are recorded (ie: margin>20dB from the applicable limit) and considered that's already beyond the background noise floor.



Operation Mode:	HSDPA Band II / TX / CH 9400	Test Date:	October 14, 2016
Temperature:	25°C	Tested by:	Eve Wang
Humidity:	55 % RH	Polarity:	Ver. / Hor.

Frequency (MHz)	Reading (dBm)	Correction Factor (dB)	Result (dBm)	Limit (dBm)	Margin (dB)	Antenna Pole (V/H)	Remark
1188.000	-53.32	-6.73	-60.05	-13.00	-47.05	V	Peak
1780.000	-57.01	-5.02	-62.03	-13.00	-49.03	V	Peak
1992.000	-60.22	-3.07	-63.29	-13.00	-50.29	V	Peak
2460.000	-58.96	-3.50	-62.46	-13.00	-49.46	V	Peak
2820.000	-63.30	-2.32	-65.62	-13.00	-52.62	V	Peak
3424.000	-63.58	0.33	-63.25	-13.00	-50.25	V	Peak
1000.0000	-58.33	1.13	-57.20	-13.00	-44.20	H	Peak
1440.000	-54.69	-5.61	-60.30	-13.00	-47.30	H	Peak
1768.000	-46.99	-4.48	-51.47	-13.00	-38.47	H	Peak
1992.000	-50.82	-3.06	-53.88	-13.00	-40.88	H	Peak
2576.000	-57.73	-2.96	-60.69	-13.00	-47.69	H	Peak
3792.000	-64.45	1.40	-63.05	-13.00	-50.05	H	Peak

Remark:

1. Measuring frequencies from 1 GHz to the 10th harmonic of highest fundamental frequency.
2. Measurements above show only up to 6 maximum emissions noted, or would be lesser, with " N/A " remark, if no specific emissions from the EUT are recorded (ie: margin>20dB from the applicable limit) and considered that's already beyond the background noise floor.



Operation Mode:	HSDPA Band II / TX / CH 9538	Test Date:	October 14, 2016
Temperature:	25°C	Tested by:	Eve Wang
Humidity:	55 % RH	Polarity:	Ver. / Hor.

Frequency (MHz)	Reading (dBm)	Correction Factor (dB)	Result (dBm)	Limit (dBm)	Margin (dB)	Antenna Pole (V/H)	Remark
1488.000	-48.63	-6.37	-55.00	-13.00	-42.00	V	Peak
1716.000	-52.13	-5.50	-57.63	-13.00	-44.63	V	Peak
1836.000	-54.86	-4.53	-59.39	-13.00	-46.39	V	Peak
2400.000	-57.96	-3.43	-61.39	-13.00	-48.39	V	Peak
2880.000	-60.53	-2.09	-62.62	-13.00	-49.62	V	Peak
3320.000	-62.55	-0.15	-62.70	-13.00	-49.70	V	Peak
1248.000	-49.01	-6.00	-55.01	-13.00	-42.01	H	Peak
1488.000	-41.50	-5.66	-47.16	-13.00	-34.16	H	Peak
1584.000	-43.03	-5.75	-48.78	-13.00	-35.78	H	Peak
1920.000	-52.78	-3.50	-56.28	-13.00	-43.28	H	Peak
2400.000	-55.80	-3.18	-58.98	-13.00	-45.98	H	Peak
2880.000	-59.07	-1.94	-61.01	-13.00	-48.01	H	Peak

Remark:

1. Measuring frequencies from 1 GHz to the 10th harmonic of highest fundamental frequency.
2. Measurements above show only up to 6 maximum emissions noted, or would be lesser, with " N/A " remark, if no specific emissions from the EUT are recorded (ie: margin>20dB from the applicable limit) and considered that's already beyond the background noise floor.



6.7 FREQUENCY STABILITY V.S. TEMPERATURE MEASUREMENT

6.7.1 LIMIT

According to FCC §2.1055, FCC §22.355, .FCC §24.235.

Frequency Tolerance: 2.5 ppm

6.7.2 MEASUREMENT EQUIPMENT USED

Name of Equipment	Manufacturer	Model	Serial Number	Last Calibration	Due Calibration
Spectrum Analyzer	Agilent	N9010A	MY52221469	10/25/2014	10/24/2015
Temperature Chamber	YOUNG CHENN	QA-LP-10	200302001	10/27/2014	10/26/2015
DC POWER	QJE	QJ3003XE	018398	N/A	N/A
Universal Radio Communication Tester	Agilent	8960	MY48367671	09/04/2014	09/03/2015

Remark: Each piece of equipment is scheduled for calibration once a year.

6.7.3 TEST CONFIGURATION

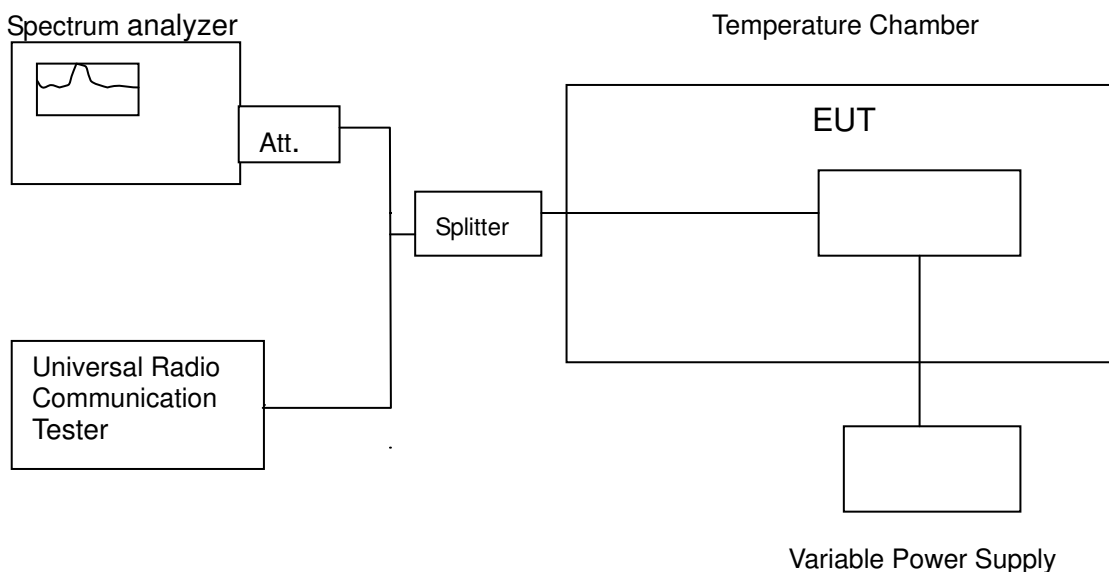

Remark: Measurement setup for testing on Antenna connector



6.7.4 TEST PROCEDURE

The equipment under test was connected to an external AC or DC power supply and input rated voltage. RF output was connected to a frequency counter or spectrum analyzer via feed through attenuators. The EUT was placed inside the temperature chamber. Set the spectrum analyzer RBW low enough to obtain the desired frequency resolution and measure EUT 20oC operating frequency as reference frequency. Turn EUT off and set the chamber temperature to -30oC. After the temperature stabilized for approximately 30 minutes recorded the frequency. Repeat step measure with 10oC increased per stage until the highest temperature of +50oC reached.



6.7.5 TEST RESULTS

No non-compliance noted.

Reference Frequency: HSDPA Band II Mid Channel 1880 MHz @ 20°C				
Limit: ± 2.5 ppm = 4700 Hz				
Power Supply Vdc	Environment Temperature (°C)	Frequency (Hz)	Delta (Hz)	Limit (Hz)
18	50	1879999996	-8	4700
	40	1879999995	-9	
	30	1879999997	-7	
	20	1880000004	0	
	10	1879999998	-6	
	0	1879999999	-5	
	-10	1880000000	-4	
	-20	1879999997	-7	
	-30	1879999999	-5	



6.8 FREQUENCY STABILITY V.S. VOLTAGE MEASUREMENT

6.8.1 LIMIT

According to FCC §2.1055, FCC §22.355, .FCC §24.235,

6.8.2 MEASUREMENT EQUIPMENT USED

Name of Equipment	Manufacturer	Model	Serial Number	Last Calibration	Due Calibration
Spectrum Analyzer	Agilent	N9010A	MY52221469	10/25/2014	10/24/2015
Temperature Chamber	YOUNG CHENN	QA-LP-10	200302001	10/27/2014	10/26/2015
DC POWER	QJE	QJ3003XE	018398	N/A	N/A
Universal Radio Communication Tester	Agilent	8960	MY48367671	09/04/2014	09/03/2015

Remark: Each piece of equipment is scheduled for calibration once a year.

6.8.3 TEST CONFIGURATION

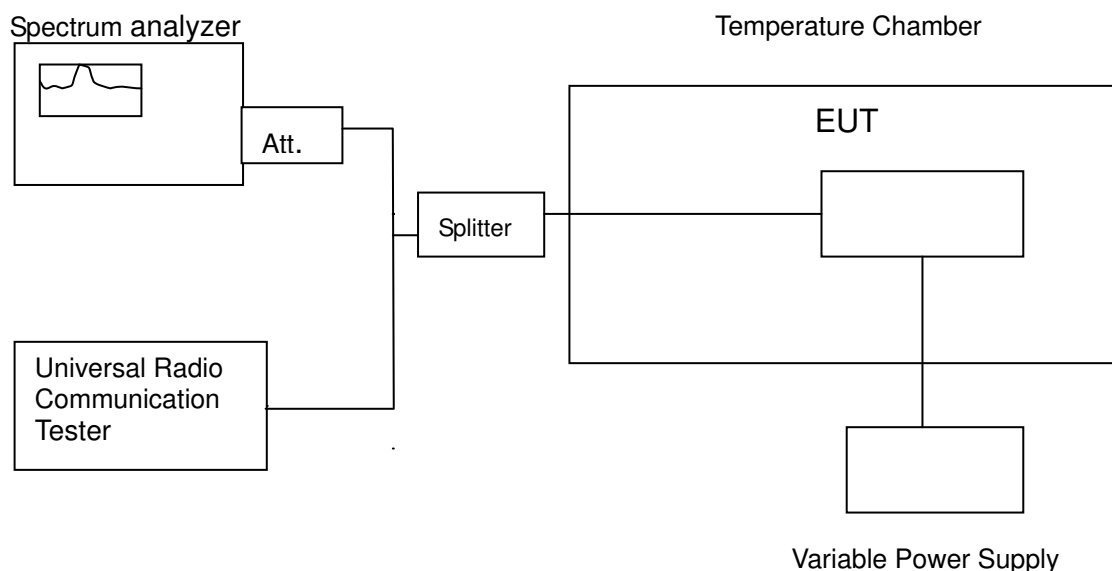

Remark: Measurement setup for testing on Antenna co

6.8.4 TEST PROCEDURE

Set chamber temperature to 20°C. Use a variable AC power supply / DC power source to power the EUT and set the voltage to rated voltage. Set the spectrum analyzer RBW low enough to obtain the desired frequency resolution and recorded the frequency.



6.8.5 TEST RESULTS

No non-compliance noted.

Reference Frequency: HSDPA Band II Mid Channel 1880 MHz @ 20°C				
Limit: ± 2.5 ppm = 4700 Hz				
Power Supply Vdc	Environment Temperature (°C)	Frequency (Hz)	Delta (Hz)	Limit (Hz)
20.7	20	1880000001	-3	4700
18.0		1880000004	0	
15.3		1880000000	-4	
12.0		1880000081	77	



6.9 POWERLINE CONDUCTED EMISSIONS

limit

For an intentional radiator which is designed to be connected to the public utility (AC) power line, the radio frequency voltage that is conducted back onto the AC power line on any frequency or frequencies within the band 150 kHz to 30 MHz shall not exceed 250 microvolts (The limit decreases linearly with the logarithm of the frequency in the range 0.15 MHz to 0.50 MHz). The limits at specific frequency range is listed as follows:

Frequency Range (MHz)	Limits (dB μ V)	
	Quasi-peak	Average
0.15 to 0.50	66 to 56	56 to 46
0.50 to 5	56	46
5 to 30	60	50

Compliance with this provision shall be based on the measurement of the radio frequency voltage between each power line (LINE and NEUTRAL) and ground at the power terminals.

measurement equipment used

Conducted Emission Test Site					
Name of Equipment	Manufacturer	Model Number	Serial Number	Last Calibration	Due Calibration
EMI TEST RECEIVER	ROHDE&SCHWARZ	ESCI	100783	02/28/2015	02/27/2016
LISN(EUT)	ROHDE&SCHWARZ	ENV216	101543-WX	02/28/2015	02/27/2016
LISN	EMCO	3825/2	8901-1459	02/28/2015	02/27/2016
Temp. / Humidity Meter	VICTOR	HTC-1	N/A	02/28/2015	02/27/2016
Test S/W	FARAD	EZ-EMC/ CCS-3A1-CE			

Remark: Each piece of equipment is scheduled for calibration once a year.



Test Configuration

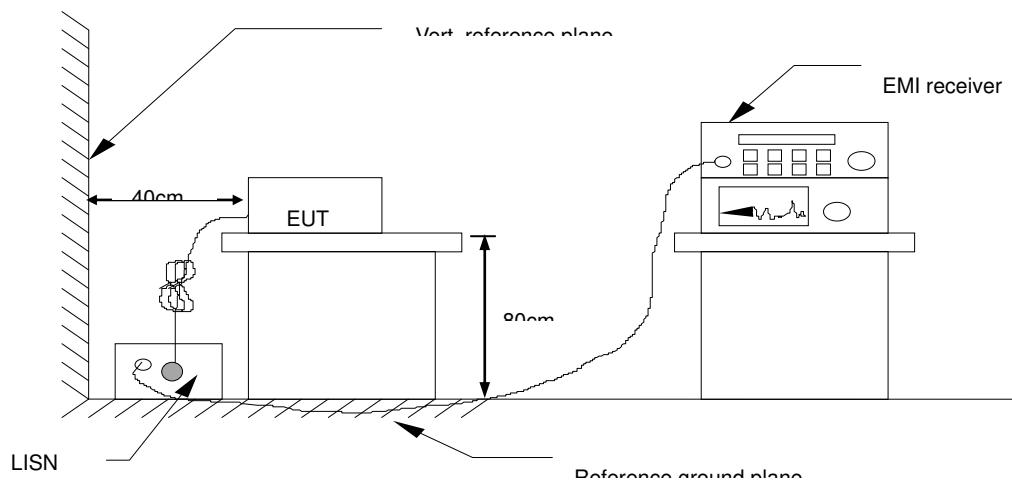

See test photographs attached in Appendix 1 for the actual connections between EUT and support equipment.

TEST PROCEDURE

1. The EUT was placed on a table, which is 0.8m above ground plane.
2. Maximum procedure was performed on the six highest emissions to ensure EUT compliance.
3. Repeat above procedures until all frequency measured were complete.

test results

The initial step in collecting conducted data is a spectrum analyzer peak scan of the measurement range. Significant peaks are then marked as shown on the following data page, and these signals are then quasi-peaked.



Test Data

Operation Mode: DC power + REC

Test Date: May 24, 2015

Temperature: 22°C

Humidity: 45% RH

Tested by: Jimmy Zheng

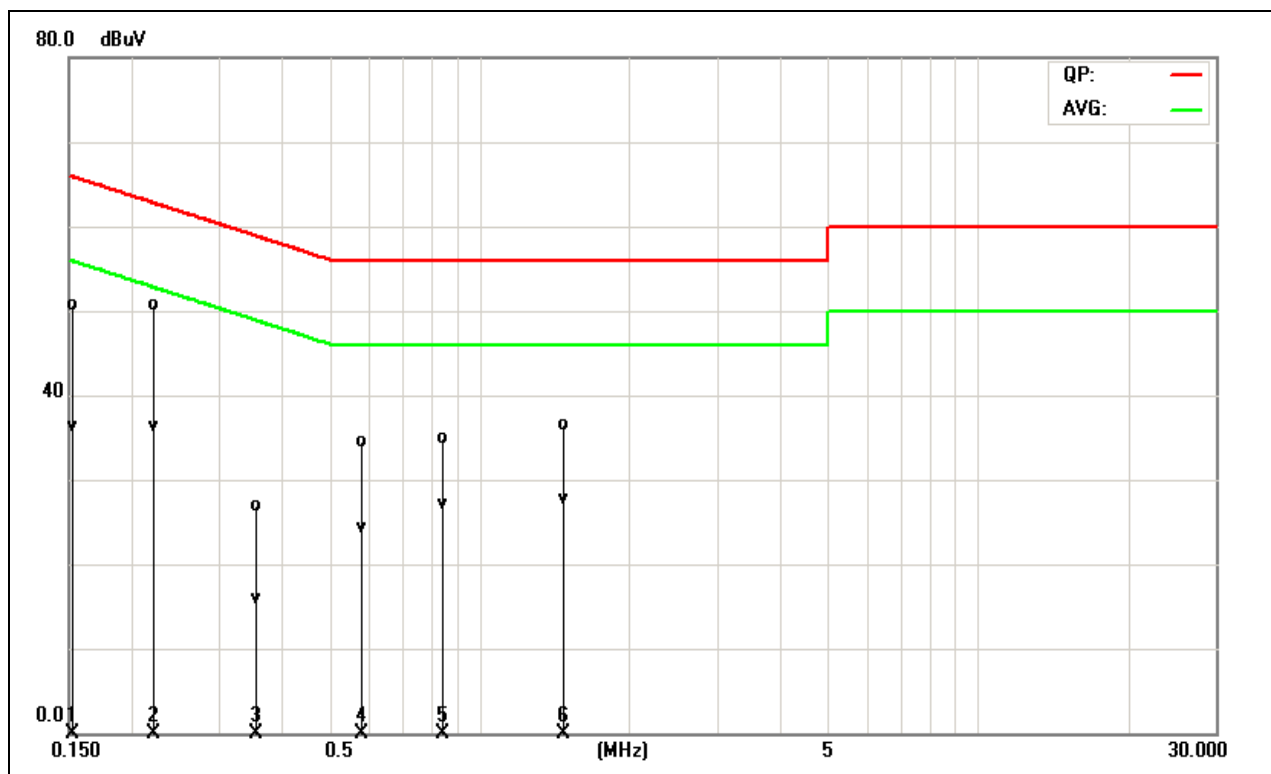

Frequency (MHz)	QuasiPeak Reading (dBuV)	Average Reading (dBuV)	Correction Factor (dB)	QuasiPeak Result (dBuV)	Average Result (dBuV)	QuasiPeak Limit (dBuV)	Average Limit (dBuV)	QuasiPeak Margin (dB)	Average Margin (dB)	Line (L1/L2)
0.1524	41.19	26.77	9.58	50.77	36.35	65.86	55.87	-15.09	-19.52	L1
0.2220	41.08	26.66	9.69	50.77	36.35	62.74	52.74	-11.97	-16.39	L1
0.3540	17.21	6.31	9.68	26.89	15.99	58.87	48.87	-31.98	-32.88	L1
0.5780	24.84	14.56	9.72	34.56	24.28	56.00	46.00	-21.44	-21.72	L1
0.8420	25.24	17.33	9.75	34.99	27.08	56.00	46.00	-21.01	-18.92	L1
1.4660	26.71	18.02	9.72	36.43	27.74	56.00	46.00	-19.57	-18.26	L1

Note:

1. Measuring frequencies from 0.15 MHz to 30MHz.
2. The emissions measured in frequency range from 0.15 MHz to 30MHz were made with an instrument using Peak detector, Quasi-peak detector and average detector.
3. “---” denotes the emission level was or more than 2dB below the Average limit.
4. The IF bandwidth of SPA between 0.15MHz to 30MHz was 10kHz; the IF bandwidth of Test Receiver between 0.15MHz to 30MHz was 9kHz;
5. L1= Line One (Live Line)



Operation Mode: DC power + REC

Test Date: May 24, 2015

Temperature: 22°C

Humidity: 45% RH

Tested by: Jimmy Zheng

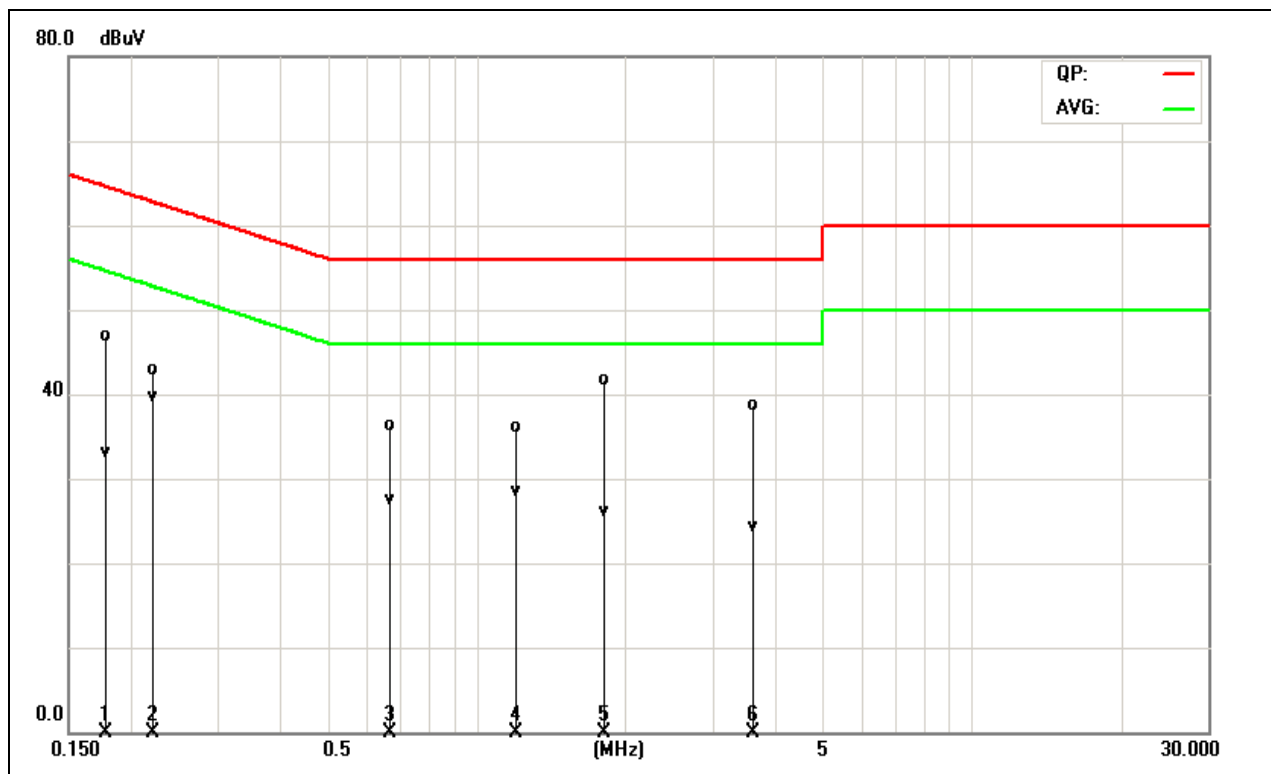

Frequency (MHz)	QuasiPeak Reading (dBuV)	Average Reading (dBuV)	Correction Factor (dB)	QuasiPeak Result (dBuV)	Average Result (dBuV)	QuasiPeak Limit (dBuV)	Average Limit (dBuV)	QuasiPeak Margin (dB)	Average Margin (dB)	Line (L1/L2)
0.1780	37.08	23.28	9.79	46.87	33.07	64.57	54.58	-17.70	-21.51	L2
0.2220	33.06	29.94	9.78	42.84	39.72	62.74	52.74	-19.90	-13.02	L2
0.6660	26.56	17.83	9.69	36.25	27.52	56.00	46.00	-19.75	-18.48	L2
1.1980	26.30	18.68	9.79	36.09	28.47	56.00	46.00	-19.91	-17.53	L2
1.8060	31.86	16.41	9.75	41.61	26.16	56.00	46.00	-14.39	-19.84	L2
3.5940	29.02	14.48	9.76	38.78	24.24	56.00	46.00	-17.22	-21.76	L2

Note:

1. Measuring frequencies from 0.15 MHz to 30MHz.
2. The emissions measured in frequency range from 0.15 MHz to 30MHz were made with an instrument using Peak detector, Quasi-peak detector and average detector.
3. "---" denotes the emission level was or more than 2dB below the Average limit.
4. The IF bandwidth of SPA between 0.15MHz to 30MHz was 10kHz; the IF bandwidth of Test Receiver between 0.15MHz to 30MHz was 9kHz;
5. L2= Line Two (Neutral Line)