



TEST REPORT

Verified code: 731547

Report No.:	E201911123807-2	Application No.:	E201911123807
Client:	K-Mark Industrial LTD		
Address:	Flat A,7/F.,Mai On Ind.Bldg., 17-21, Kung Yip St.,Kwai Chung, Hongkong		
Sample Description:	Feeder meter with antenna		
Model:	AH-FMTR-ANT		
FCC ID:	VEPGL-AHFMTRANT		
Test Location:	Guangzhou GRG Metrology and Test Co., Ltd.		
Test Specification:	CFR 47, FCC Parts 15 C		
Test Date:	2020/02/17 to 2020/03/11		
Issue Date:	2020/04/14		
Test Result:	PASS		
Prepared By: Test Engineer <i>Wu Haobing</i>	Reviewed By: Technical Manager <i>Wu Chengrong</i>	Approved By: Manager <i>Zhu Yan</i>	
Other Aspects:			
Note: /			
Abbreviations: ok / P = passed; fail / F = failed; n.a. / N = not applicable;			
The test result in this test report refers exclusively to the presented test sample. This report shall not be reproduced except in full, without the written approval of GRGT.			



DIRECTIONS OF TEST

1. This company carries out test task according to the national regulation of verifications which can be traced to National Primary Standards and BIPM.
2. The test report merely corresponds to the test sample. It is not permitted to copy extracts of these test result without the written permission of the test laboratory.
3. If there is any objection concerning the test, the client should inform the laboratory within 15 days from the date of receiving the test report.

TABLE OF CONTENTS

1. TEST RESULT SUMMARY	4
2. GENERAL DESCRIPTION OF EUT.....	5
2.1. APPLICANT	5
2.2. MANUFACTURER	5
2.3. FACTORY	5
2.4. BASIC DESCRIPTION OF EQUIPMENT UNDER TEST	5
2.5. TEST OPERATION MODE	6
2.6. LOCAL SUPPORTIVE.....	6
3. LABORATORY AND ACCREDITATIONS	7
3.1. LABORATORY	7
3.2. ACCREDITATIONS	7
3.3. MEASUREMENT UNCERTAINTY	7
4. LIST OF USED TEST EQUIPMENT AT GRGT.....	8
5. ANTENNA REQUIREMENT	9
6. RADIATED SPURIOUS EMISSIONS	10
6.1. LIMITS.....	10
6.2. TEST PROCEDURES(PLEASE REFER TO MEASUREMENT STANDARD).....	10
6.3. TEST SETUP	14
6.4. DATA SAMPLE	15
6.5. TEST RESULTS	16
7. 6DB BANDWIDTH.....	22
7.1 LIMITS	22
7.2 TEST PROCEDURES	22
7.3 TEST SETUP	22
7.4 TEST RESULTS	22
8. MAXIMUM PEAK OUTPUT POWER.....	25
8.1 LIMITS	25
8.2 TEST PROCEDURES	25
8.3 TEST SETUP	25
8.4 TEST RESULTS	25
9. POWER SPECTRAL DENSITY.....	26
9.1 LIMITS	26
9.2 TEST PROCEDURES	26
9.3 TEST SETUP	26
9.4 TEST RESULTS	26
10. CONDUCTED BAND EDGES AND SPURIOUS EMISSIONS	29
10.1 LIMITS.....	29
10.2 TEST PROCEDURES.....	29
10.3 TEST SETUP	29
10.4 TEST RESULTS	30
11. RESTRICTED BANDSOF OPERATION.....	33
11.1 LIMITS.....	33
11.2 TEST PROCEDURES.....	33
11.3 TEST SETUP	34
11.4 TEST RESULTS	35

1. TEST RESULT SUMMARY

Standard	Item	Limit / Severity	Result
CFR 47, FCC Parts 15 C	Antenna Requirement	§15.203	PASS
	Conducted Emissions	§15.207 (a)	N/A ¹⁾
	Radiated Spurious Emission	§15.247(d)	PASS
	6 dB Bandwidth	§15.247 (a)(2)	PASS
	Maximum Peak Output Power	§15.247(b)(3)	PASS
	Power Spectral Density	§15.247(e)	PASS
	Conducted band edges and Spurious Emission	§15.247(d)	PASS
	Restricted bands of operation	§15.205	PASS

Note: [1]: Not applicable because the EUT device is DC powered.

2. GENERAL DESCRIPTION OF EUT

2.1. APPLICANT

Name: K-Mark Industrial LTD
Address: Flat A,7/F.,Mai On Ind.Bldg.,17-21,Kung Yip St.,KwaiChung,Hong Kong

2.2. MANUFACTURER

Name: K-Mark Industrial LTD
Address: Flat A,7/F.,Mai On Ind.Bldg.,17-21,Kung Yip St.,KwaiChung,Hong Kong

2.3. FACTORY

Factory 1

Name : K-Mark Industrial (Shenzhen) LTD
Address : 43 Jinshi Road, niuhu Guangpei community, Guanlan street, Longhua District, Shenzhen

2.4. BASIC DESCRIPTION OF EQUIPMENT UNDER TEST

Equipment: Feeder meter with antenna
Model No.: AH-FMTR-ANT
Adding Model: /
Model /
Discrepancy:
Trade Name: GSM LLC

Power Supply: DC3V power from the battery
Frequency Range: 2402 ~ 2480 MHz
Transmit Power: 0.57dBm
Modulation type: GFSK for 1Mbps
Antenna Specification: External Antenna with 2dBi gain(Max)
Temperature Range: -20°C ~ +60°C
Hardware Version: V2.0
Software Version: V5.0
Note: Feeder Meter with Antenna support one PCB antenna and one external antenna, break PCB antenna from BT modular RF output port, connect external antenna from break port, only external antenna can work.

2.5. TEST OPERATION MODE

Test Item	Mode No.	Description of the modes
Radiated Emission	1	Continuously Transmitting

2.6. LOCAL SUPPORTIVE

Name of Equipment	Manufacturer	Model	Serial Number	Note
Battery*2(3V)	/	/	/	/
Mobile phone	HUAWEI glory	CUN-AL00	CYSBBBA711301203	/

Test software:

Software version	Test level
HN-testing	V2.0

3. LABORATORY AND ACCREDITATIONS

3.1. LABORATORY

The tests and measurements refer to this report were performed by Shenzhen EMC Laboratory of Guangzhou GRG Metrology and Test Co., Ltd.

Add. : No.1301 Guanguang Road Xinlan Community, Guanlan Street, Longhua District Shenzhen, 518110, People's Republic of China

Telephone : +86-755-61180008

Fax : /

3.2. ACCREDITATIONS

A2LA	Certificate Number 2861.01
------	----------------------------

3.3. MEASUREMENT UNCERTAINTY

Where relevant, the following measurement uncertainty levels have been estimated for tests performed on the EUT as specified in CISPR 16-4-2:

Measurement		Frequency	Uncertainty
Radiated Emission	Horizontal	30MHz~1000MHz	4.3dB
		1GHz~18GHz	5.6dB
	Vertical	30MHz~1000MHz	4.3dB
		1GHz~18GHz	5.6dB

This uncertainty represents an expanded uncertainty factor of $k=2$.

4. LIST OF USED TEST EQUIPMENT AT GRGT

Name of Equipment	Manufacturer	Model	Serial Number	Calibration Due
Radiated Spurious Emission&Restricted bands of operation				
Spectrum analyser	Agilent	N9010A	MY52221469	2020/11/18
Power Meter	Anritsu	ML2495A	1204003	2020-04-24
Bilog Antenna	Schwarzbeck	VULB9160	9160-3401	2020/11/27
Horn Antenna	Schwarzbeck	BBHA9120	D286	2020/11/27
Pulse power transducer	Agilent	MA2411B	1126150	2020/04/24
Amplifier	Tonscend	TAP0101848	AP19L806048	/
Amplifier	Tonscend	TAP0106030	AP20B806055	/
Amplifier	Agilent	8449B	3008A02060	2020/11/18
Plate and band horn antenna	Schwarzbeck	BBHA 9170	BBHA 9170-497	2020/11/30
RF automation switching switch	Tonscend	JS0806-F	19K8060203	/
Radiation stray automatic test software	Tonscend	JS36-RSE/2.5.2.2		
Radiation stray automatic test software	Tonscend	JS36-RE/2.5.2.2		
6 dB Bandwidth				
EXA signal analyzer	Agilent	N9010A	MY52221469	2020/11/18
Maximum Peak Output Power				
Power Meter	Anritsu	ML2495A	1204003	2020-04-24
Pulse power transducer	Agilent	MA2411B	1126150	2020/04/24
Conducted band edges and Spurious Emission				
EXA signal analyzer	Agilent	N9010A	MY52221469	2020/11/18
Power Spectral Density				
EXA signal analyzer	Agilent	N9010A	MY52221469	2020/11/18

5. ANTENNA REQUIREMENT

The EUT has one antenna. The antenna is Monopole antenna.

The max gain of antenna is 2dBi .which accordance 15.203.is considered sufficient to comply with the provisions of this section.

Feeder Meter with Antenna suport one PCB antenna and one external antenna, break PCB antenna from BT modular RF output port, connect external antenna from break port, only external antenna can work.

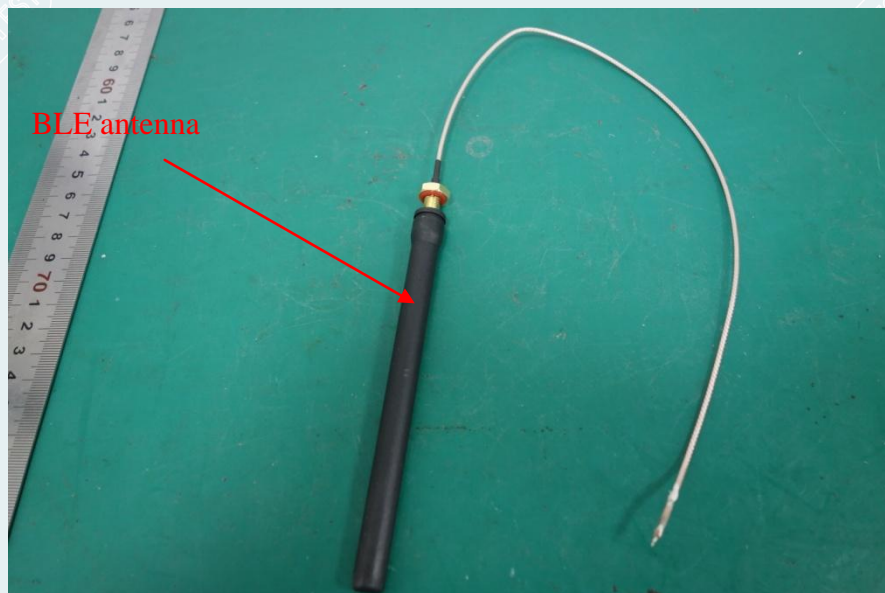
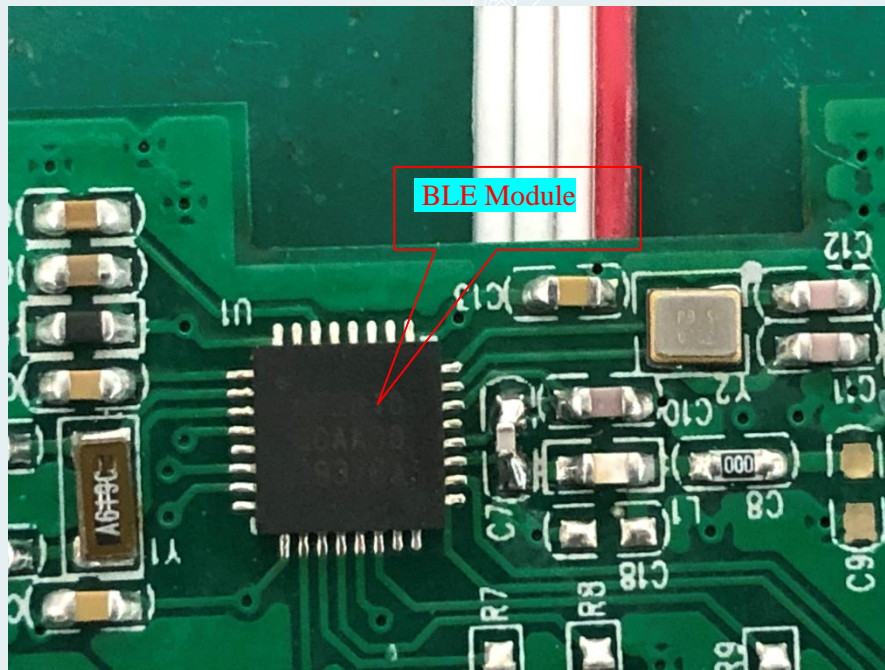

6. RADIATED SPURIOUS EMISSIONS

6.1. LIMITS

In any 100 kHz bandwidth outside the frequency band in which the spread spectrum or digitally modulated intentional radiator is operating, the radio frequency power that is produced by the intentional radiator shall be at least 20 dB below that in the 100 kHz bandwidth within the band that contains the highest level of the desired power, based on either an RF conducted or a radiated measurement, provided the transmitter demonstrates compliance with the peak conducted power limits. If the transmitter complies with the conducted power limits based on the use of RMS averaging over a time interval, as permitted under paragraph (b)(3) of this section, the attenuation required under this paragraph shall be 30 dB instead of 20 dB. Attenuation below the general limits specified in §15.209(a) is not required.

Frequency (MHz)	Quasi-peak($\mu\text{V}/\text{m}$)	Measurement distance(m)	Quasi-peak($\text{dB}\mu\text{V}/\text{m}$)@distance 3m
0.009-0.490	2400/F(kHz)	300	53.8~88.5
0.490-1.705	24000/F(kHz)	30	43~53.8
1.705-30.0	30	30	49.5
30 ~ 88	100	3	40
88~216	150	3	43.5
216 ~ 960	200	3	46
Above 960	500	3	54

NOTE: (1) The lower limit shall apply at the transition frequencies.

6.2. TEST PROCEDURES (please refer to measurement standard)

1) Sequence of testing 9 kHz to 30 MHz

Setup:

- The equipment was set up to simulate a typical usage like described in the user manual or described by manufacturer.
- If the EUT is a tabletop system, a rotatable table with 0.8 m height is used.
- If the EUT is a floor standing device, it is placed on the ground.
- Auxiliary equipment and cables were positioned to simulate normal operation conditions.
- The AC power port of the EUT (if available) is connected to a power outlet below the turntable.
- The measurement distance is 3 meter.
- The EUT was set into operation.

Premeasurement:

- The turntable rotates from 0° to 315° using 45° steps.
- The antenna height is 0.8 meter.
- At each turntable position the analyzer sweeps with peak detection to find the maximum of all emissions

Final measurement:

- Identified emissions during the premeasurement the software maximizes by rotating the turntable position (0° to 360°) and by rotating the elevation axes (0° to 360°).
- The final measurement will be done in the position (turntable and elevation) causing the highest emissions with QPK detector.
- The final levels, frequency, measuring time, bandwidth, turntable position, correction factor, margin to the limit and limit will be recorded. Also a plot with the graph of the premeasurement and the limit will be stored.

2) Sequence of testing 30 MHz to 1 GHz**Setup:**

- The equipment was set up to simulate a typical usage like described in the user manual or described by manufacturer.
- If the EUT is a tabletop system, a table with 0.8 m height is used, which is placed on the ground plane.
- If the EUT is a floor standing device, it is placed on the ground plane with insulation between both.
- Auxiliary equipment and cables were positioned to simulate normal operation conditions
- The AC power port of the EUT (if available) is connected to a power outlet below the turntable.
- The measurement distance is 3 meter.
- The EUT was set into operation.

Premeasurement:

- The turntable rotates from 0° to 315° using 45° steps.
- The antenna is polarized vertical and horizontal.
- The antenna height changes from 1 to 3 meter.
- At each turntable position, antenna polarization and height the analyzer sweeps three times in peak to find the maximum of all emissions.

Final measurement:

- The final measurement will be performed with minimum the six highest peaks.
- According to the maximum antenna and turntable positions of premeasurement the software maximize the peaks by changing turntable position ($\pm 45^\circ$) and antenna movement between 1 and 4 meter.
- The final measurement will be done with QP detector with an EMI receiver.
- The final levels, frequency, measuring time, bandwidth, antenna height, antenna polarization, turntable angle, correction factor, margin to the limit and limit will be recorded. Also a plot with the graph of the premeasurement with marked maximum final measurements and the limit will be stored.

3) Sequence of testing 1 GHz to 18 GHz**Setup:**

- The equipment was set up to simulate a typical usage like described in the user manual or described by manufacturer.
- If the EUT is a tabletop system, a rotatable table with 1.5 m height is used.
- If the EUT is a floor standing device, it is placed on the ground plane with insulation between both.
- Auxiliary equipment and cables were positioned to simulate normal operation conditions
- The AC power port of the EUT (if available) is connected to a power outlet below the turntable.
- The measurement distance is 3 meter.
- The EUT was set into operation.

Premeasurement:

- The turntable rotates from 0° to 315° using 45° steps.
- The antenna is polarized vertical and horizontal.
- The antenna height scan range is 1 meter to 2.5 meter.
- At each turntable position and antenna polarization the analyzer sweeps with peak detection to find the maximum of all emissions.

Final measurement:

- The final measurement will be performed with minimum the six highest peaks.
- According to the maximum antenna and turntable positions of premeasurement the software maximize the peaks by changing turntable position ($\pm 45^\circ$) and antenna movement between 1 and 4 meter. This procedure is repeated for both antenna polarizations.
- The final measurement will be done in the position (turntable, EUT-table and antenna polarization) causing the highest emissions with Peak and Average detector.
- The final levels, frequency, measuring time, bandwidth, turntable position, EUT-table position, antenna polarization, correction factor, margin to the limit and limit will be recorded. Also a plot with the graph of the premeasurement with marked maximum final measurements and the limit will be stored.

4) Sequence of testing above 18 GHz Setup:

- The equipment was set up to simulate a typical usage like described in the user manual or described by manufacturer.
- If the EUT is a tabletop system, a rotatable table with 1.5 m height is used.
- If the EUT is a floor standing device, it is placed on the ground plane with insulation between both.
- Auxiliary equipment and cables were positioned to simulate normal operation conditions
- The AC power port of the EUT (if available) is connected to a power outlet below the turntable.
- The measurement distance is 1 meter.
- The EUT was set into operation.

Premeasurement:

- The antenna is moved spherical over the EUT in different polarisations of the antenna.

Final measurement:

- The final measurement will be performed at the position and antenna orientation for all detected emissions that were found during the premeasurements with Peak and Average detector.
- The final levels, frequency, measuring time, bandwidth, correction factor, margin to the limit and limit will be recorded. Also a plot with the graph of the premeasurement and the limit will be stored.

NOTE: The resolution bandwidth of test receiver/spectrum analyzer is 1MHz and the video bandwidth is 3MHz for RMS Average (Duty cycle < 98%) for Average detection (AV) at frequency above 1GHz, then the measurement results was added to a correction factor ($10 \log(1/\text{duty cycle})$).

6.3. TEST SETUP

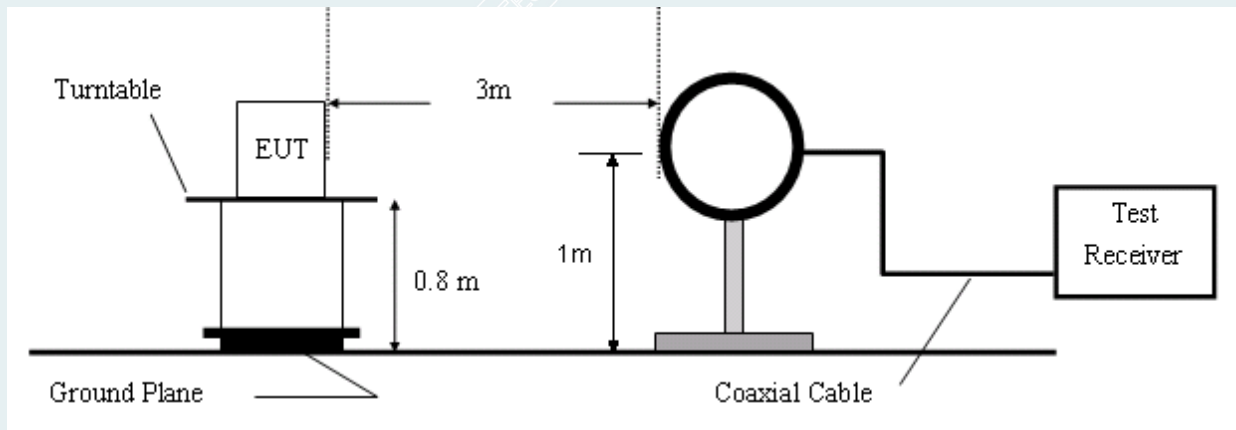

Figure 1.9KHz to 30MHz radiated emissions test configuration

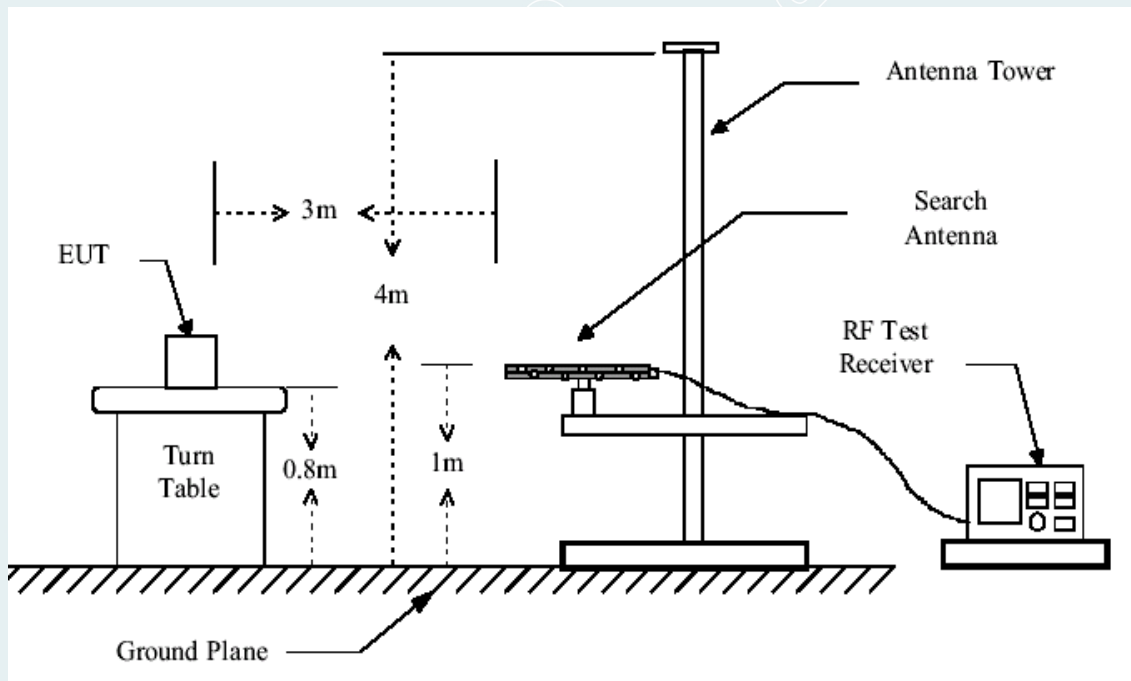

Figure 2. 30MHz to 1GHz radiated emissions test configuration

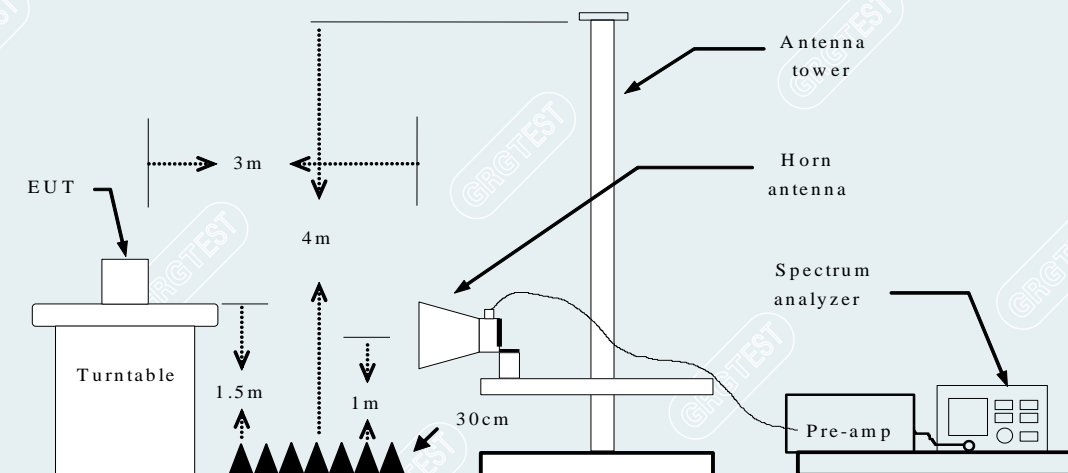

Figure 3. Above 1GHz radiated emissions test configuration

6.4. DATA SAMPLE

30MHz to 1GHz

No.	Frequency	Reading	Correct	Result	Limit	Margin	Remark	Pole
	(MHz)	(dBuV/m)	Factor(dB/m)	(dBuV/m)	(dBuV/m)	(dB)		
xxx	xxx	37.06	-15.48	21.58	40.00	-18.42	QP	Vertical

Above 1 GHz

No.	Frequency	Reading	Correct	Result	Limit	Margin	Remark	Pole
	(MHz)	(dBuV/m)	Factor(dB/m)	(dBuV/m)	(dBuV/m)	(dB)		
xxx	xxx	65.45	-11.12	54.33	74.00	-19.67	peak	Vertical
xxx	xxx	63.00	-11.12	51.88	54.00	-2.12	AVG	Vertical

Frequency (MHz)	= Emission frequency in MHz
Ant.Pol. (H/V)	= Antenna polarization
Reading (dBuV)	= Uncorrected Analyzer / Receiver reading
Correction Factor (dB/m)	= Antenna factor + Cable loss – Amplifier gain
Result (dBuV/m)	= Reading (dBuV) + Correction Factor (dB/m)
Limit (dBuV/m)	= Limit stated in standard
Margin (dB)	= Remark Result (dBuV/m) – Limit (dBuV/m)
Peak	= Peak Reading
QP	= Quasi-peak Reading
AVG	= Average Reading

6.5. TEST RESULTS

30MHz to 1GHz:

Mode: TX

Highest channel (2402MHz)

Date:2020/03/11

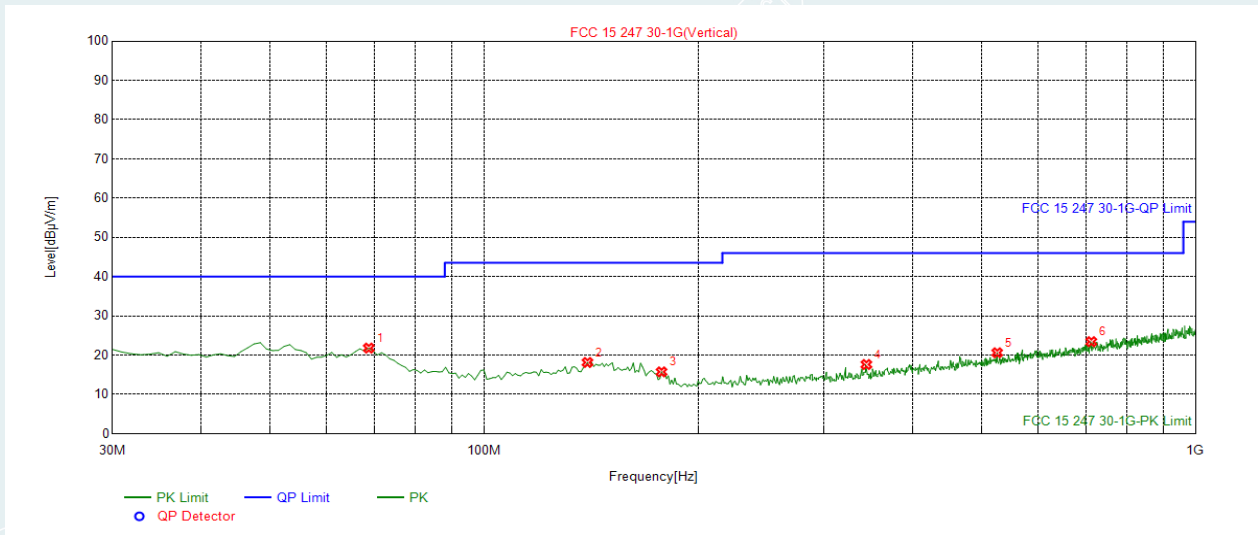

No.	Frequency	Reading	Correct	Result	Limit	Margin	Remark	Pole
	(MHz)	(dBuV/m)	Factor(dB/m)	(dBuV/m)	(dBuV/m)	(dB)		
1	68.8	51.26	-29.47	21.79	40.00	18.21	Peak	Vertical
2	139.61	42.88	-24.74	18.14	43.50	25.36	Peak	Vertical
3	177.44	40.82	-25.08	15.74	43.50	27.76	Peak	Vertical
4	344.28	39.61	-21.99	17.62	46.00	28.38	Peak	Vertical
5	525.67	37.65	-17.04	20.61	46.00	25.39	Peak	Vertical
6	712.88	36.48	-13.05	23.43	46.00	22.57	Peak	Vertical

Mode: TX
 Highest channel (2402MHz)

Date:2020/03/11

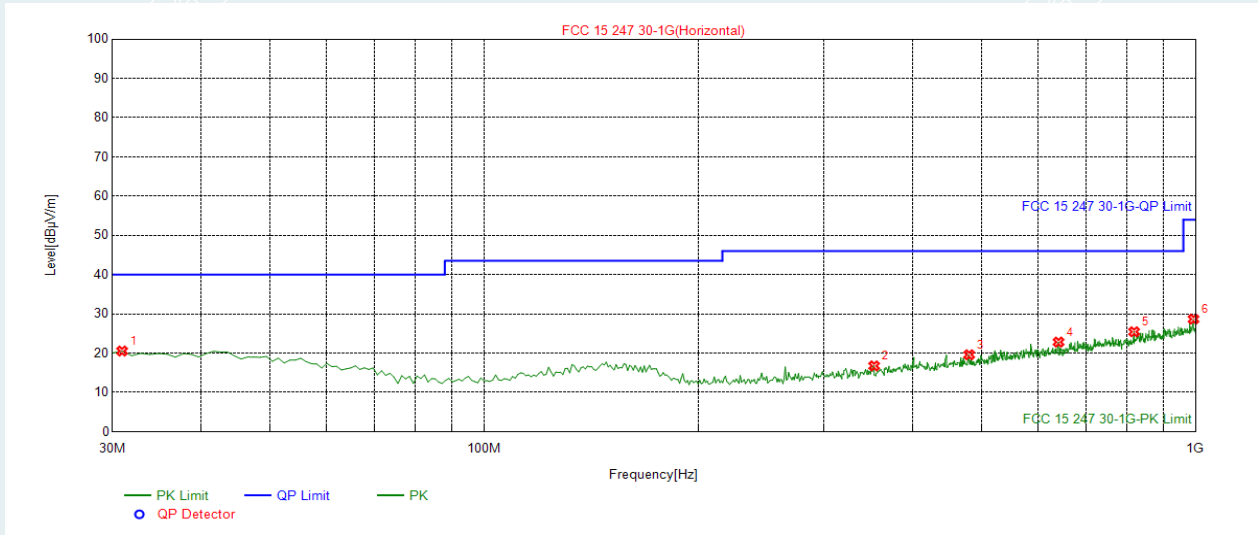

No.	Frequency	Reading	Correct	Result	Limit	Margin	Remark	Pole
	(MHz)	(dBuV/m)	Factor(dB/m)	(dBuV/m)	(dBuV/m)	(dB)		
1	30.97	48.89	-28.35	20.54	40.00	19.46	Peak	Horizontal
2	353.01	38.47	-21.72	16.75	46.00	29.25	Peak	Horizontal
3	480.08	37.74	-18.15	19.59	46.00	26.41	Peak	Horizontal
4	641.1	37.09	-14.27	22.82	46.00	23.18	Peak	Horizontal
5	818.61	36.69	-11.25	25.44	46.00	20.56	Peak	Horizontal
6	992.24	37	-8.34	28.66	54.00	25.34	Peak	Horizontal

Mode: TX
 Highest channel (2480MHz)

Date:2020/03/11

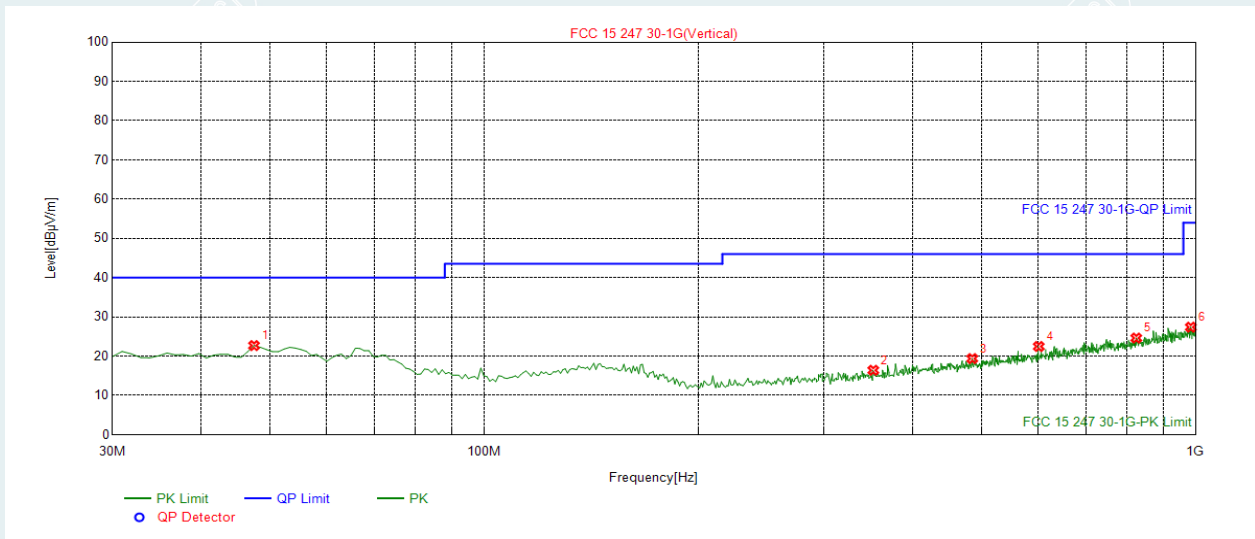

No.	Frequency	Reading	Correct	Result	Limit	Margin	Remark	Pole
	(MHz)	(dBuV/m)	Factor (dB/m)	(dBuV/m)	(dBuV/m)	(dB)		
1	47.46	50.51	-27.82	22.69	40.00	17.31	Peak	Vertical
2	352.04	38.15	-21.75	16.4	46.00	29.6	Peak	Vertical
3	484.93	37.41	-18.03	19.38	46.00	26.62	Peak	Vertical
4	601.33	37.47	-15.01	22.46	46.00	23.54	Peak	Vertical
5	824.43	35.69	-11.08	24.61	46.00	21.39	Peak	Vertical
6	983.51	35.83	-8.45	27.38	54.00	26.62	Peak	Vertical

Mode: TX
 Highest channel (2480MHz)

Date:2020/03/11

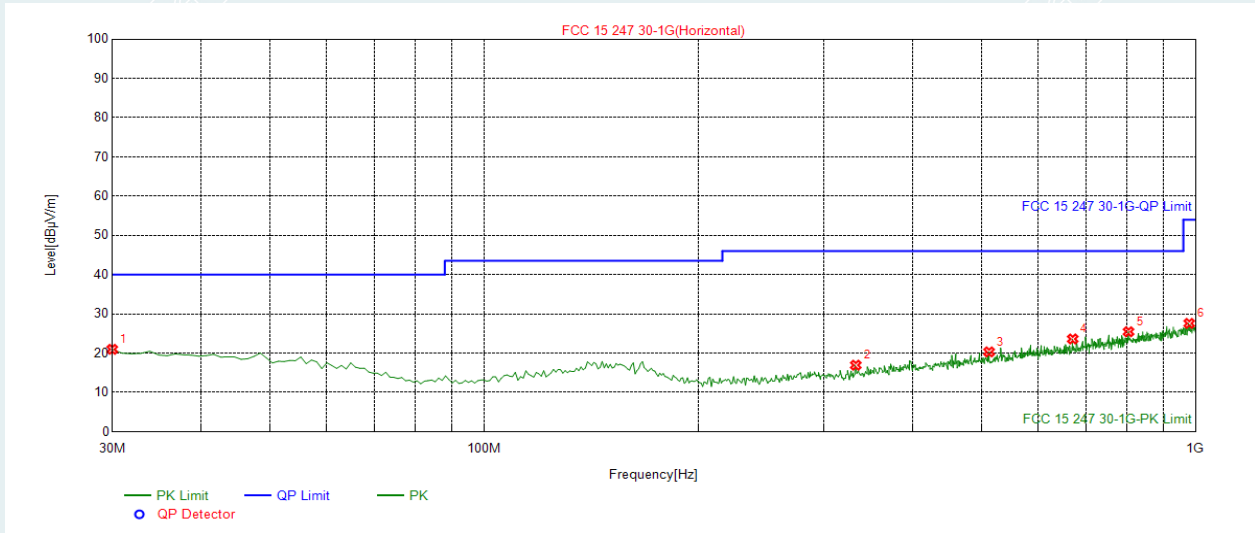

No.	Frequency (MHz)	Reading (dBuV/m)	Correct Factor (dB/m)	Result (dBuV/m)	Limit (dBuV/m)	Margin (dB)	Remark	Pole
1	30	49.39	-28.42	20.97	40.00	19.03	Peak	Horizontal
2	332.64	39.29	-22.35	16.94	46.00	29.06	Peak	Horizontal
3	512.09	37.71	-17.39	20.32	46.00	25.68	Peak	Horizontal
4	671.17	37.4	-13.79	23.61	46.00	22.39	Peak	Horizontal
5	804.06	37.04	-11.59	25.45	46.00	20.55	Peak	Horizontal
6	978.66	36.14	-8.56	27.58	54.00	26.42	Peak	Horizontal

Remark:

- 1 No emission found between lowest internal used/generated frequency to 30MHz.
- 2 Radiated emissions measured in frequency range from 9 kHz to 1GHz were made with an instrument using Quasi-peak detector mode.
- 3 Data of measurement within this frequency range shown “---” in the table above means the reading of emissions are attenuated more than 20dB below the permissible limits or the field strength is too small to be measured.
- 4 The IF bandwidth of Receiver between 30MHz to 1GHz was 120 kHz.

Above 1GHz:

Mode: TX

Lowest channel (2402MHz)

Date: 2020/03/11

No.	Frequency	Reading	Correct	Result	Limit	Margin	Remark	Pole
	(MHz)	(dBuV/m)	Factor(dB/m)	(dBuV/m)	(dBuV/m)	(dB)		
1	3360.3604	47.66	-5.69	41.97	74.00	32.03	peak	Vertical
2	4009.009	46.78	-4.23	42.55	74.00	31.45	peak	Vertical
3	4648.6486	46.24	-2.68	43.56	74.00	30.44	peak	Vertical
4	4801.8018	56.93	-2.37	54.56	74.00	19.44	peak	Vertical
5	6702.7027	46.52	1.65	48.17	74.00	25.83	peak	Vertical
6	7207.2072	47.95	3.02	50.97	74.00	23.03	peak	Vertical
7	4804.0586	48.63	-2.36	46.27	54.00	7.73	AVG	Vertical
8	3576.5766	47.6	-5.39	42.21	74.00	31.79	peak	Horizontal
9	4126.1261	46.03	-3.91	42.12	74.00	31.88	peak	Horizontal
10	4495.4955	46.46	-3.09	43.37	74.00	30.63	peak	Horizontal
11	4801.8018	59.28	-2.37	56.91	74.00	17.09	peak	Horizontal
12	5459.4595	46.63	-1.16	45.47	74.00	28.53	peak	Horizontal
13	6270.2703	46.51	0.47	46.98	74.00	27.02	peak	Horizontal
14	4804.0586	50.94	-2.36	48.58	54.00	5.42	AVG	Horizontal

Mode: TX

Middle channel (2440MHz)

Date: 2020/03/11

No.	Frequency	Reading	Correct	Result	Limit	Margin	Remark	Pole
	(MHz)	(dBuV/m)	Factor(dB/m)	(dBuV/m)	(dBuV/m)	(dB)		
1	3837.8378	46.37	-4.64	41.73	74	32.27	Peak	Vertical
2	4468.4685	45.61	-3.12	42.49	74	31.51	Peak	Vertical
3	4801.8018	55.62	-2.37	53.25	74	20.75	Peak	Vertical
4	5207.2072	47.16	-1.62	45.54	74	28.46	Peak	Vertical
5	5846.8468	45.88	-0.57	45.31	74	28.69	Peak	Vertical
6	7207.2072	49.03	3.02	52.05	74	21.95	Peak	Vertical
7	4801.80	48.73	-2.37	46.36	54	7.64	AVG	Vertical
8	4351.3514	45.29	-3.36	41.93	74	32.07	peak	Horizontal
9	4495.4955	45.42	-3.09	42.33	74	31.67	peak	Horizontal
10	4801.8018	54.64	-2.37	52.27	74	21.73	peak	Horizontal
11	5450.4505	46.14	-1.17	44.97	74	29.03	peak	Horizontal
12	6072.0721	46.11	-0.26	45.85	74	28.15	peak	Horizontal
13	7207.2072	46.03	3.02	49.05	74	24.95	peak	Horizontal
14	4801.8018	47.68	-2.37	45.31	54.00	8.69	AVG	Horizontal

Mode: TX

Highest channel (2480MHz)

Date: 2020/03/11

No.	Frequency	Reading	Correct	Result	Limit	Margin	Remark	Pole
	(MHz)	(dBuV/m)	Factor(dB/m)	(dBuV/m)	(dBuV/m)	(dB)		
1	4504.5045	46.53	-3.08	43.45	74	30.55	peak	Vertical
2	4801.8018	58.28	-2.37	55.91	74	18.09	peak	Vertical
3	5306.3063	46.28	-1.41	44.87	74	29.13	peak	Vertical
4	5405.4054	46.74	-1.21	45.53	74	28.47	peak	Vertical
5	5954.955	46.12	-0.48	45.64	74	28.36	peak	Vertical
6	6432.4324	45.86	0.95	46.81	74	27.19	peak	Vertical
7	4804.0106	48.78	-2.36	46.42	54	7.58	AVG	Vertical
8	2711.7117	49.79	-6.51	43.28	74	30.72	peak	Horizontal
9	3522.5225	47.09	-5.52	41.57	74	32.43	peak	Horizontal
10	3981.982	45.79	-4.3	41.49	74	32.51	peak	Horizontal
11	4234.2342	45.97	-3.73	42.24	74	31.76	peak	Horizontal
12	4567.5676	46.65	-2.93	43.72	74	30.28	peak	Horizontal
13	4801.8018	54.66	-2.37	52.29	74	21.71	peak	Horizontal
14	4801.8018	47.36	-2.37	44.99	54	9.01	AVG	Horizontal

Remark:

- 1 Measuring frequencies from 1 GHz to the 10th harmonic of highest fundamental frequency.
- 2 Radiated emissions measured in frequency above 1000MHz were made with an instrument using peak/average detector mode.
- 3 Average test would be performed if the peak result were greater than the average limit or as required by the applicant.
- 4 Data of measurement within this frequency range shown " --- " in the table above means the reading of emissions are attenuated more than 20dB below the permissible limits or the field strength is too small to be measured.
- 5 Measurements above show only up to 6 maximum emissions noted, or would be lesser, with " N/A " remark, if no specific emissions from the EUT are recorded (ie: margin>20dB from the applicable limit) and considered that's already beyond the background noise floor.

7. 6DB BANDWIDTH

7.1 LIMITS

Systems using digital modulation techniques may operate in the 902–928 MHz, 2400–2483.5 MHz, and 5725–5850 MHz bands. The minimum 6 dB bandwidth shall be at least 500 kHz.

7.2 TEST PROCEDURES

- 1) Remove the antenna from the EUT, and then connect a low loss RF cable from antenna port to the spectrum analyzer.
- 2) Set resolution bandwidth (RBW) = 100kHz. Set the video bandwidth (VBW) $\geq 3 \times$ RBW. Detector = Peak. Trace mode = max hold. Sweep = auto couple. Allow the trace to stabilize, record 6dB bandwidth value.
- 3) Repeat above procedures until all frequencies measured were complete.

7.3 TEST SETUP



7.4 TEST RESULTS

Channel	Frequency (MHz)	Bandwidth (kHz)	Limit (kHz)	Test Result
Lowest	2402	714.6	>500	PASS
Middle	2440	714.3		PASS
Highest	2480	723.6		PASS

Lowest channel (2402MHz)

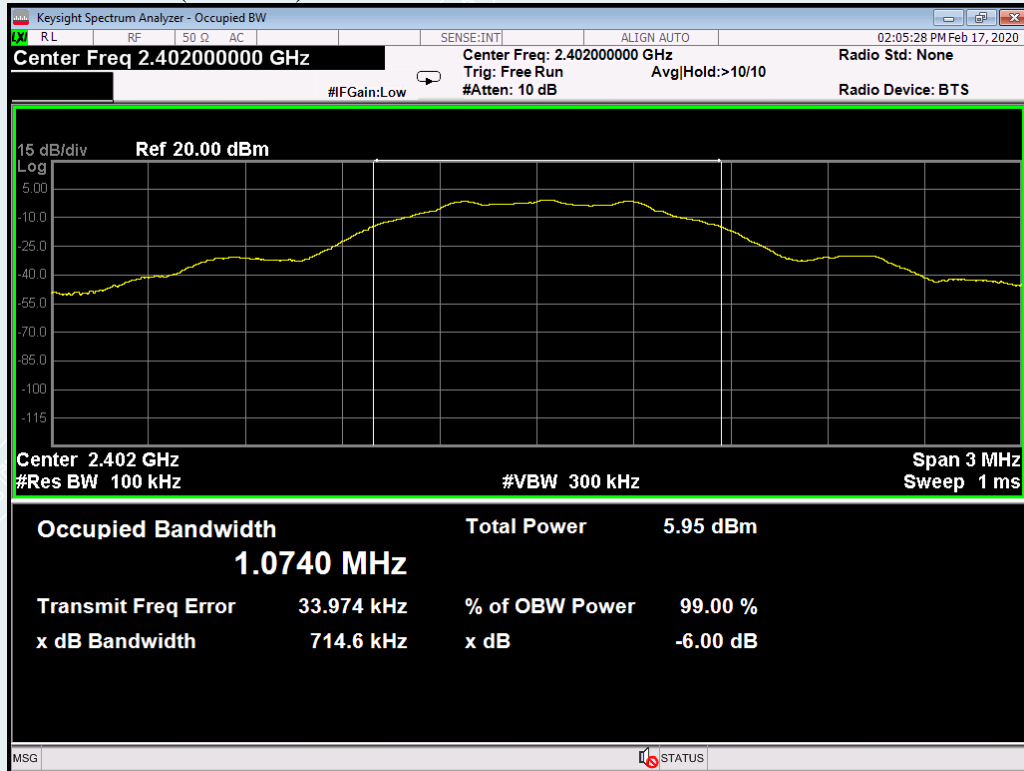

Middle channel (2440 MHz)

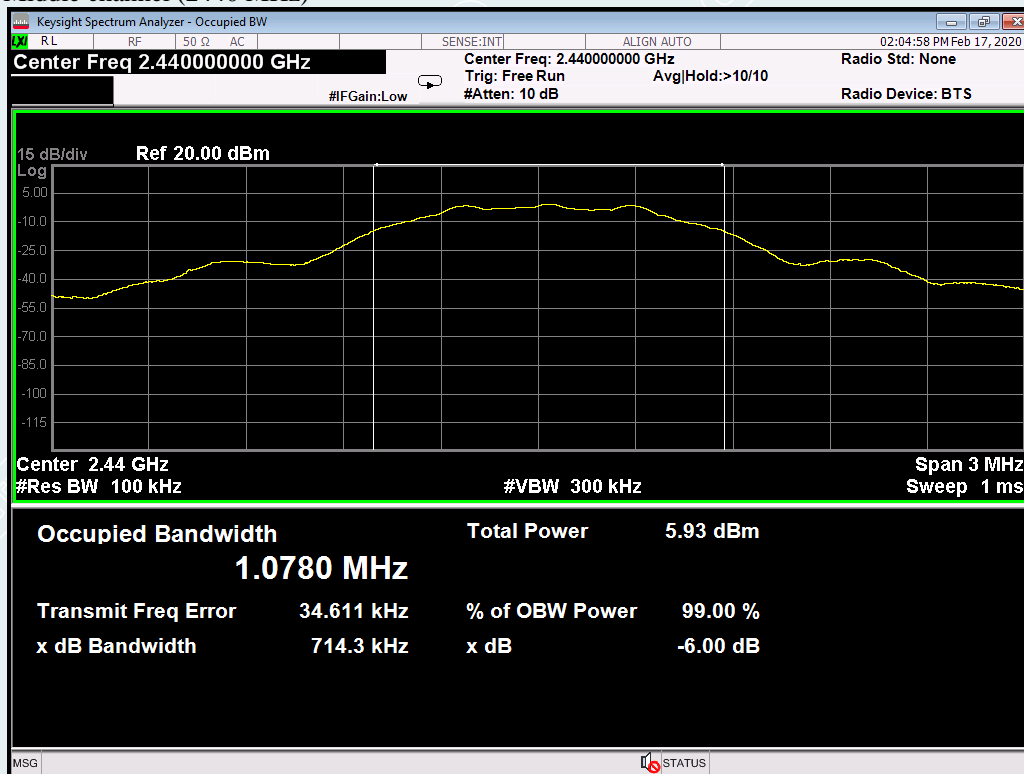

Highest channel (2480MHz)

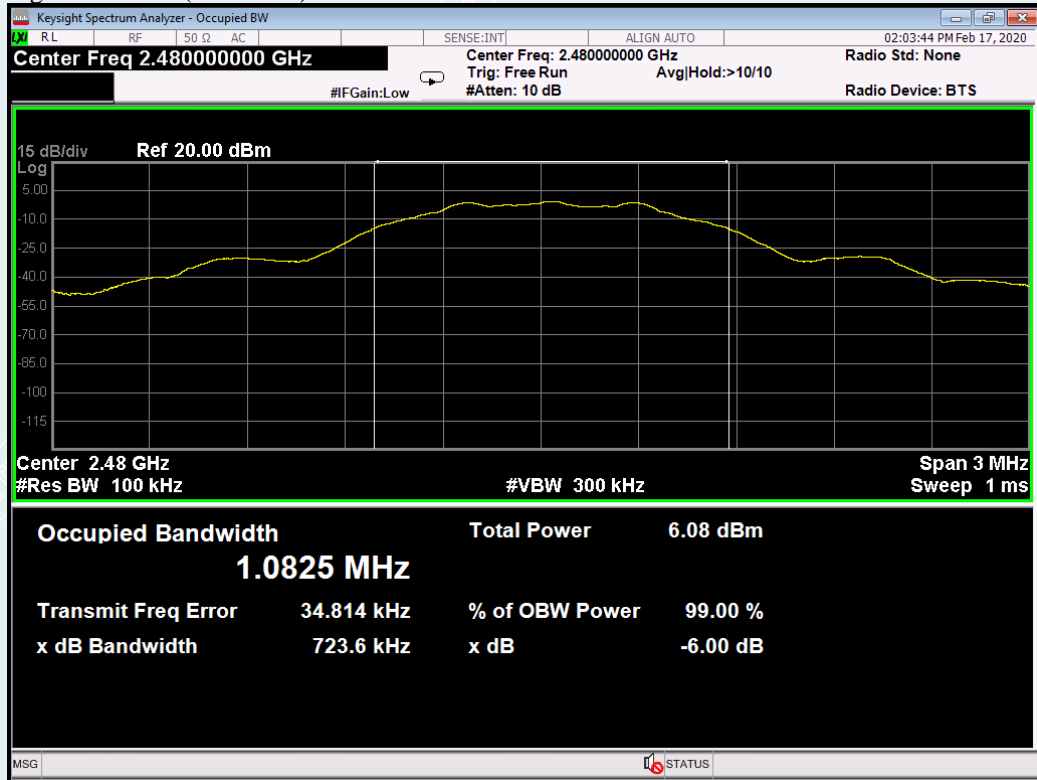

8. MAXIMUM PEAK OUTPUT POWER

8.1 LIMITS

The maximum Peak output power measurement is 1W

8.2 TEST PROCEDURES

- 1) Place the EUT on a bench and set it in transmitting mode.
- 2) Remove the antenna from the EUT and then connect a low loss RF cable from the antenna port to an EMI Test Receiver.
- 3) The spectrum analyzer resolution bandwidth that is \leq EBW. So we test the Maximum Conducted Output Power —Integrated band power method.
- 4) Set the analyzer span $\geq 1.5 \times$ DTS bandwidth. Set the RBW = 1 MHz. Set the VBW ≥ 3 MHz. Sweep time = auto couple. Detector = peak. Allow trace to fully stabilize.

8.3 TEST SETUP

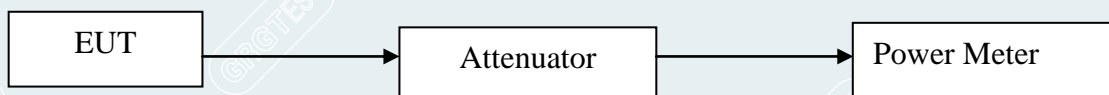

8.4 TEST RESULTS

Channel	Frequency (MHz)	Measured Channel Power (dBm)	Limit	Peak/Average	Result
Lowest	2402	0.57	1W (30dBm)	Peak	Pass
Middle	2440	0.46			Pass
Highest	2480	0.28			Pass
Lowest	2402	-1.48		Average	Pass
Middle	2440	-1.62			Pass
Highest	2480	-1.82			Pass

9. POWER SPECTRAL DENSITY

9.1 LIMITS

For digitally modulated systems, the power spectral density conducted from the intentional radiator to the antenna shall not be greater than 8 dBm in any 3 kHz band during any time interval of continuous transmission. This power spectral density shall be determined in accordance with the provisions of paragraph (b) of this section. The same method of determining the conducted output power shall be used to determine the power spectral density.

9.2 TEST PROCEDURES

- 1) Remove the antenna from the EUT, and then connect a low loss RF cable from antenna port to the spectrum analyzer.
- 2) Position the EUT was set without connection to measurement instrument. Turn on the EUT and connect its antenna terminal to measurement instrument via a low loss cable. Then set it to any one measured frequency within its operating range, and make sure the instrument is operated in its linear range.
- 3) Set the analyzer span to 1.5 times the DTS bandwidth. Set the RBW = 3 kHz. Set the VBW \geq 3 RBW. Detector = peak. Ensure that the number of measurement points in the sweep \geq 2 x span/RBW (use of a greater number of measurement points than this minimum requirement is recommended).
- 4) Repeat above procedures until all frequencies measured were complete.

9.3 TEST SETUP



9.4 TEST RESULTS

Channel	Frequency (MHz)	PPSD (dBm)	Limit (dBm/3kHz)	Test Result
Lowest	2402	-16.240	8	PASS
Middle	2440	-16.250		PASS
Highest	2480	-16.162		PASS

Lowest channel (2402MHz)

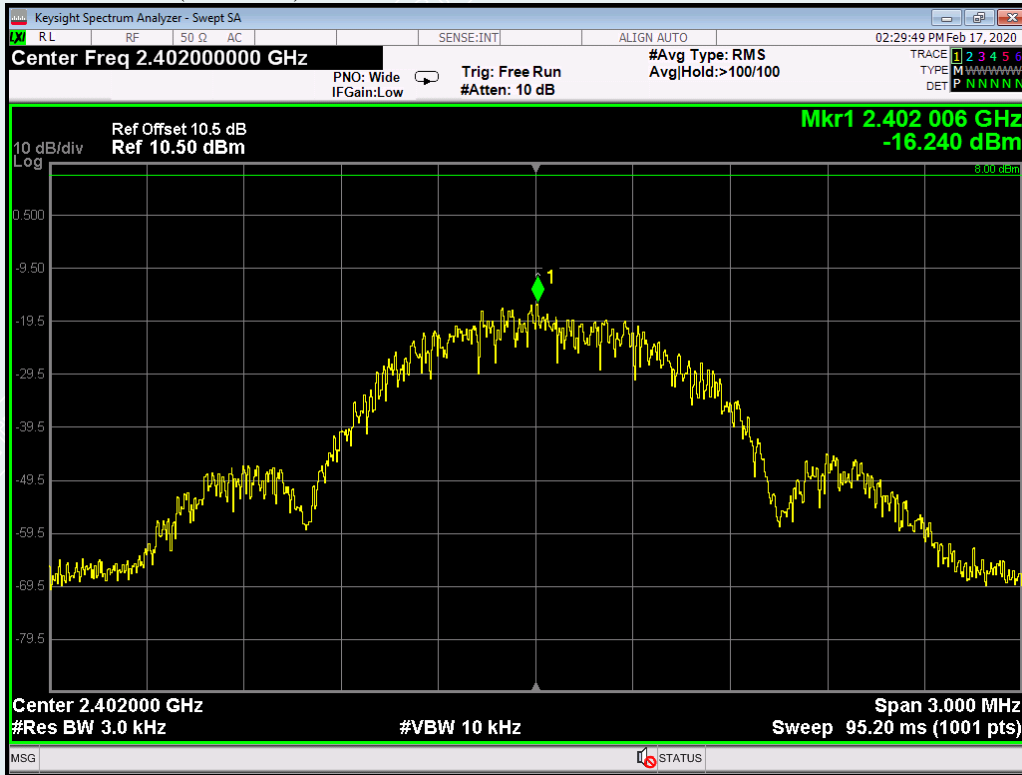

Middle channel (2440 MHz)

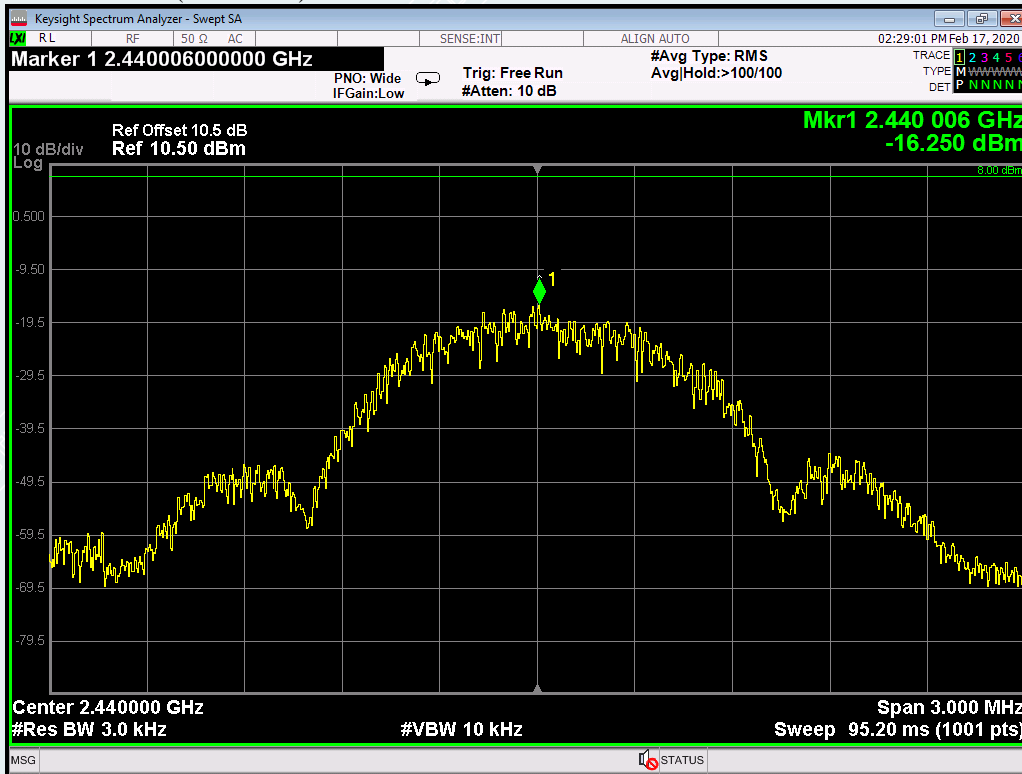

Highest channel (2480MHz)

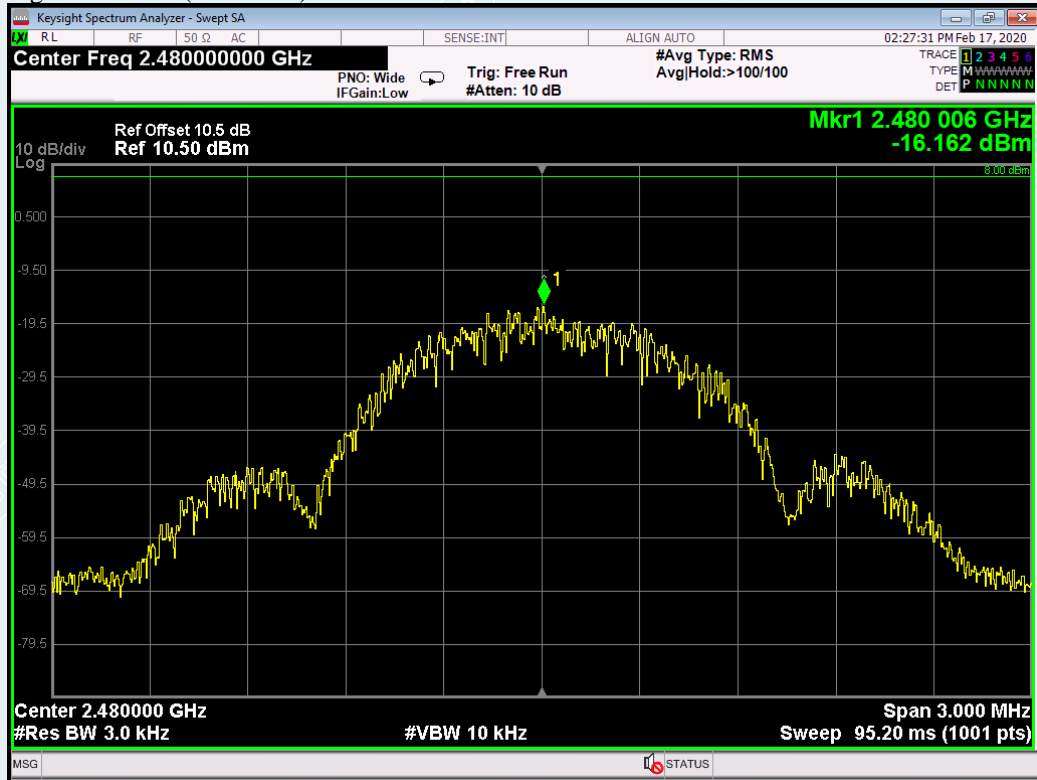

10. CONDUCTED BAND EDGES AND SPURIOUS EMISSIONS

10.1 LIMITS

(d) In any 100 kHz bandwidth outside the frequency band in which the spread spectrum or digitally modulated intentional radiator is operating, the radio frequency power that is produced by the intentional radiator shall be at least 20 dB below that in the 100 kHz bandwidth within the band that contains the highest level of the desired power, based on either an RF conducted or a radiated measurement, provided the transmitter demonstrates compliance with the peak conducted power limits. If the transmitter complies with the conducted power limits based on the use of RMS averaging over a time interval, as permitted under paragraph (b)(3) of this section, the attenuation required under this paragraph shall be 30 dB instead of 20 dB.

10.2 TEST PROCEDURES

Test procedures follow KDB 558074 D01 DTS Measurement Guidance v03r01.

Remove the antenna from the EUT and then connect a low attenuation cable from the antenna port to the spectrum.

- 1) Remove the antenna from the EUT and then connect a low attenuation cable from the antenna port to the spectrum.
- 2) Set the spectrum analyzer: RBW =100KHz; VBW =300KHz, Span = 10MHz to 26GHz; Sweep = auto; Detector Function = Peak. Trace = Max, hold.
- 3) Measure and record the results in the test report.
- 4) The RF fundamental frequency should be excluded against the limit line in the operating frequency band.

10.3 TEST SETUP



10.4 TEST RESULTS

Lowest channel (2402MHz)
0.01GHz-26.5GHz

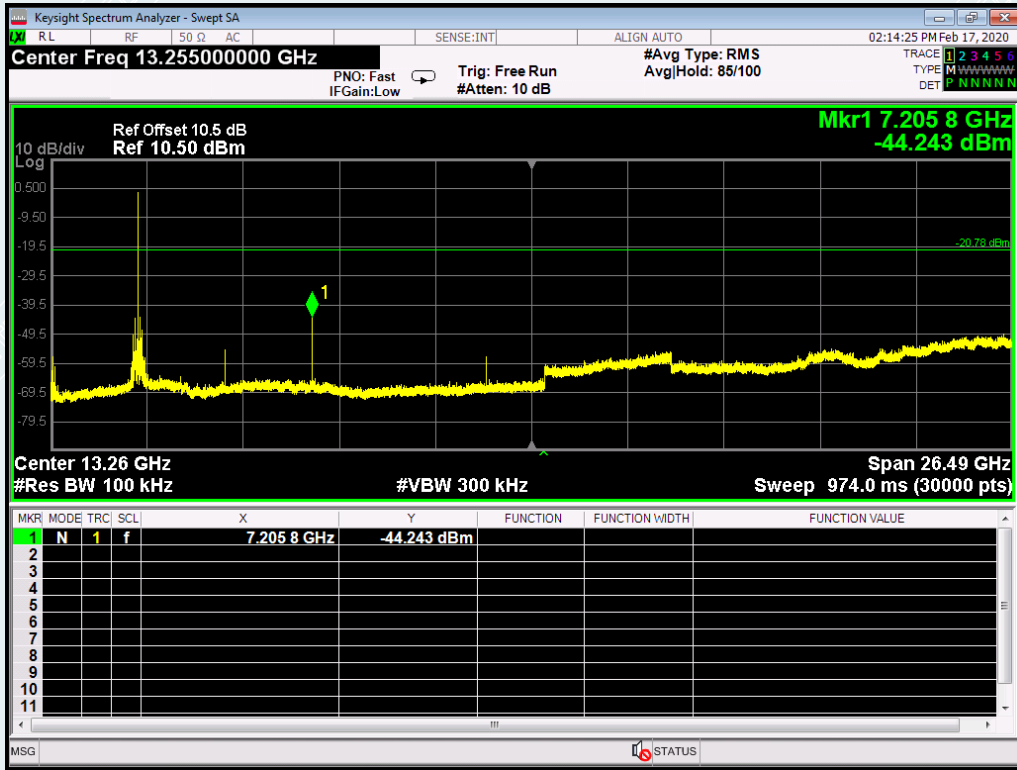

2.31GHz-2.41GHz

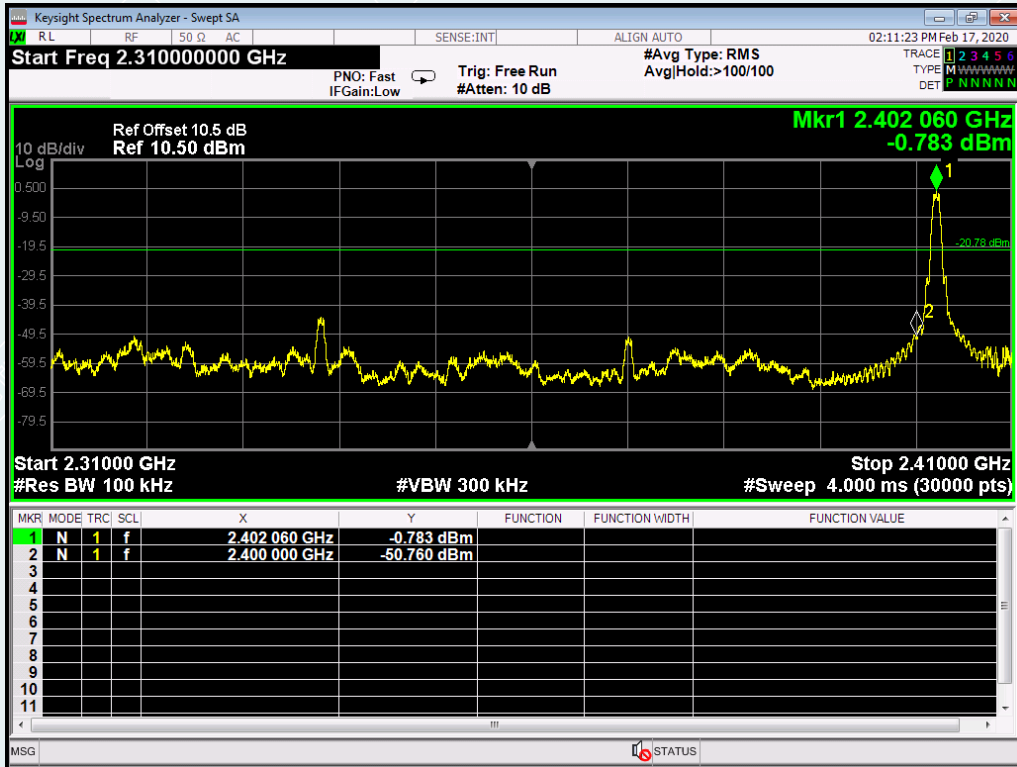

Middle channel (2440 MHz)
0.01GHz-26.5GHz

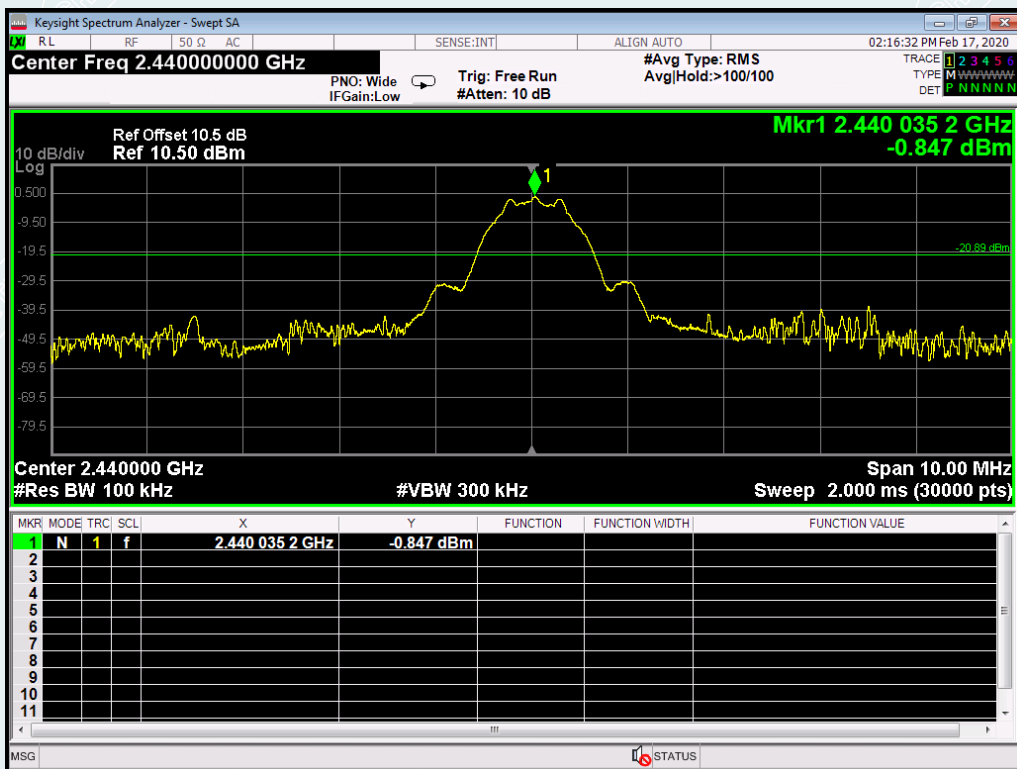
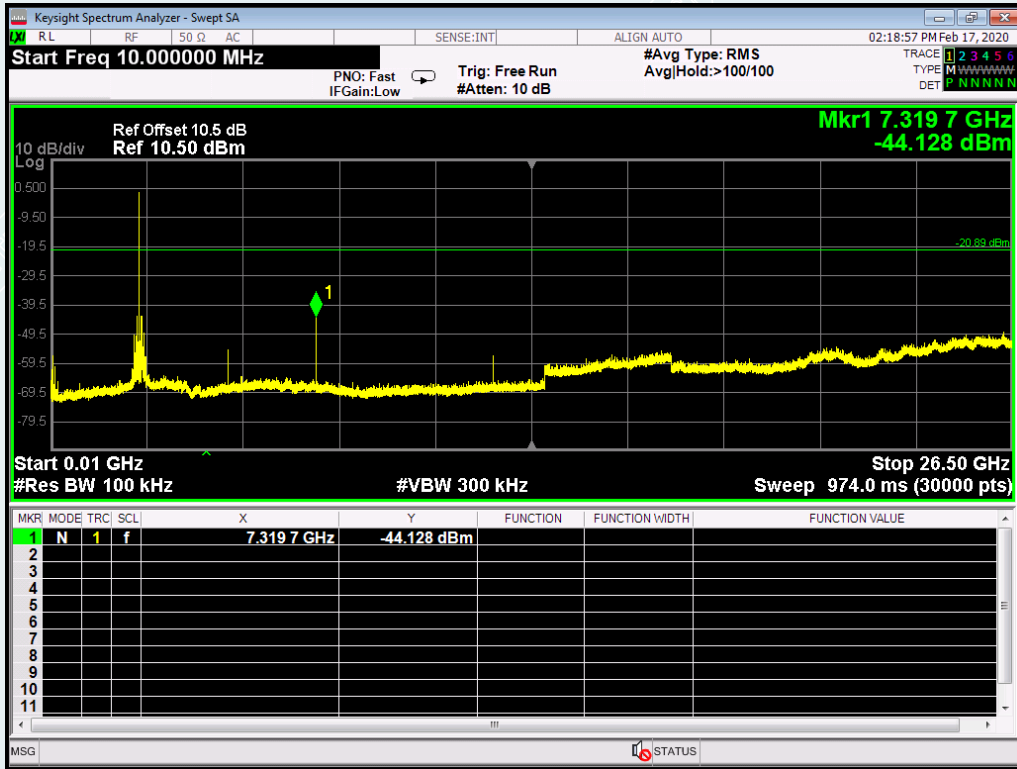

Highest channel (2480MHz)
0.01GHz-26.5GHz

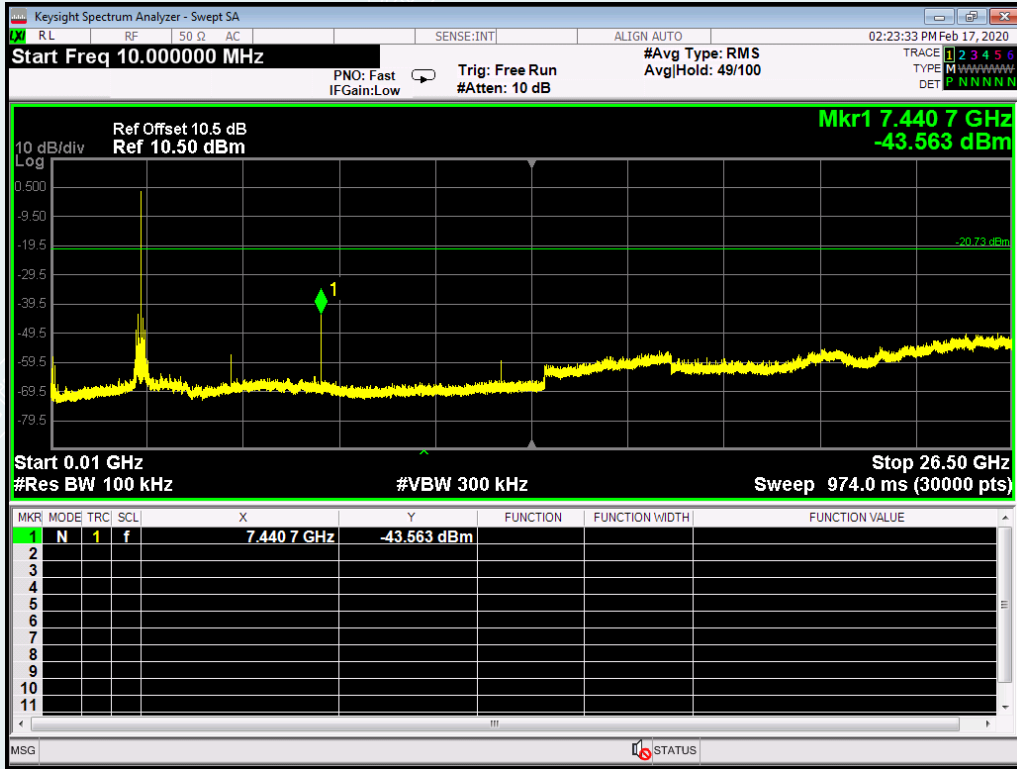

2.475GHz-2.5GHz

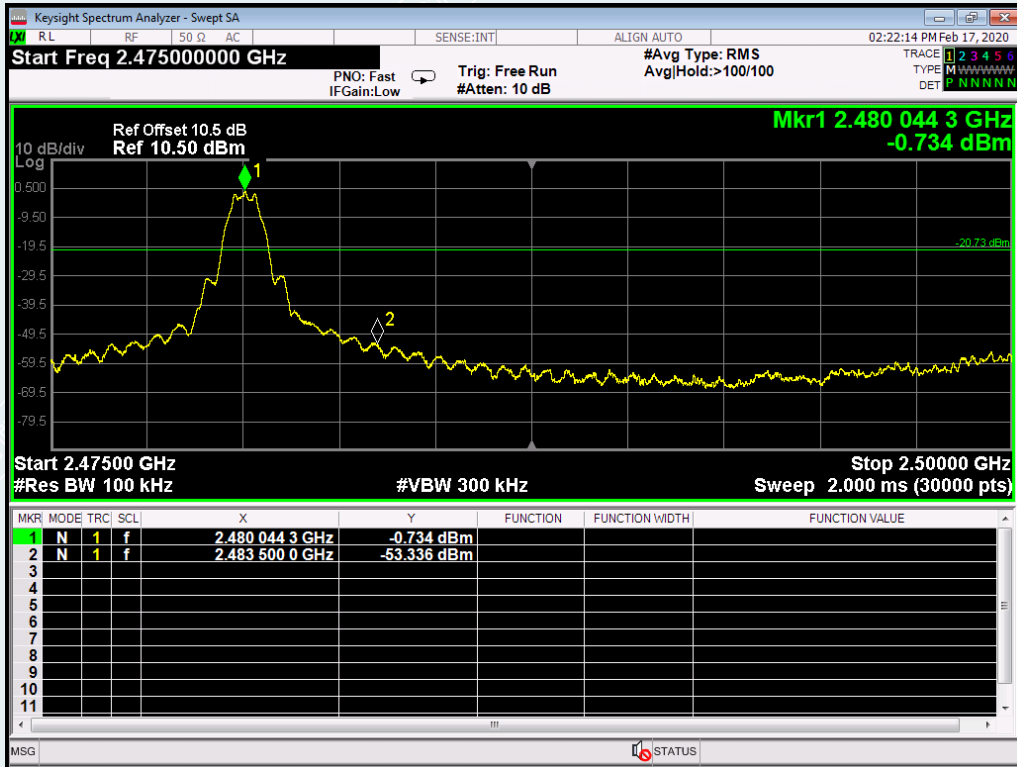

11. RESTRICTED BANDS OF OPERATION

11.1 LIMITS

Section 15.247(d) In addition, Radiated emissions which fall in the restricted bands, as defined in §15.205(a), must also comply with the radiated emission limits specified in §15.209(a) (see §15.205(c)).

MHz	MHz	MHz	GHz
0.090 - 0.110	16.42 - 16.423	399.9 - 410	4.5 - 5.15
¹ 0.495 - 0.505	16.69475 -	608 - 614	5.35 - 5.46
2.1735 - 2.1905	16.69525	960 - 1240	7.25 - 7.75
4.125 - 4.128	16.80425 -	1300 - 1427	8.025 - 8.5
4.17725 - 4.17775	16.80475	1435 - 1626.5	9.0 - 9.2
4.20725 - 4.20775	25.5 - 25.67	1645.5 - 1646.5	9.3 - 9.5
6.215 - 6.218	37.5 - 38.25	1660 - 1710	10.6 - 12.7
6.26775 - 6.26825	73 - 74.6	1718.8 - 1722.2	13.25 - 13.4
6.31175 - 6.31225	74.8 - 75.2	2200 - 2300	14.47 - 14.5
8.291 - 8.294	108 - 121.94	2310 - 2390	15.35 - 16.2
8.362 - 8.366	123 - 138	2483.5 - 2500	17.7 - 21.4
8.37625 - 8.38675	149.9 - 150.05	2655 - 2900	22.01 - 23.12
8.41425 - 8.41475	156.52475 -	3260 - 3267	23.6 - 24.0
12.29 - 12.293	156.52525	3332 - 3339	31.2 - 31.8
12.51975 -	156.7 - 156.9	3345.8 - 3358	36.43 - 36.5
12.52025	162.0125 - 167.17	3600 - 4400	
12.57675 -	167.72 - 173.2		
12.57725	240 - 285		
13.36 - 13.41	322 - 335.4		

11.2 TEST PROCEDURES

Test procedures follow KDB 558074 D01 DTS Meas Guidance v03r01.

- 1) The EUT is placed on a turntable, which is 1.5m above the ground plane.
- 2) The turntable shall be rotated for 360 degrees to determine the position of maximum emission level.
- 3) EUT is set 3m away from the receiving antenna, which is varied from 1m to 4m to find out the highest emission.
- 4) Set the spectrum analyzer in the following setting in order to capture the lower and upper band-edges of the emission:
 - a) PEAK: RBW=1MHz / VBW=1MHz / Sweep=AUTO
 - b) AVERAGE: RBW=1MHz / VBW=1/T / Sweep=AUTO
- 5) Repeat the procedures until all the PEAK and AVERAGE versus POLARIZATION are measured.

11.3 TEST SETUP

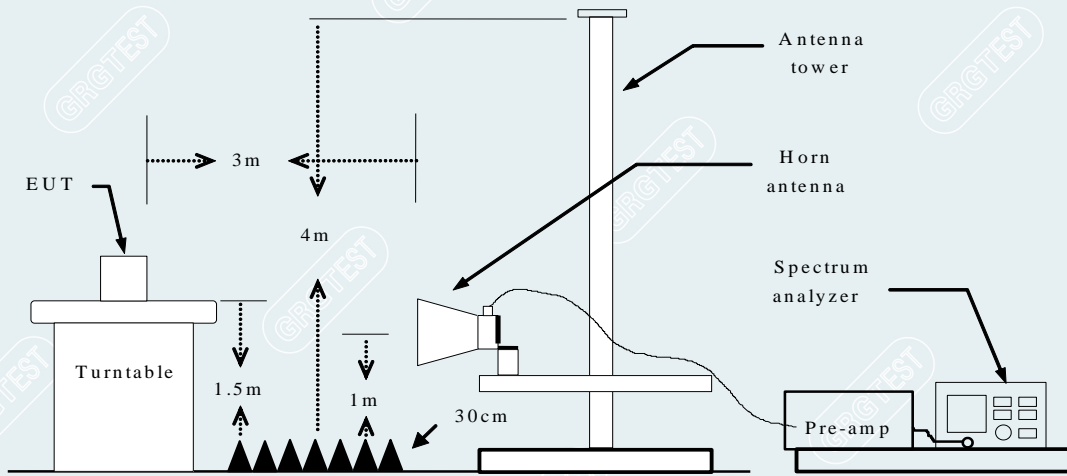

11.4 TEST RESULTS

Lowest Channel

Detector mode: Peak

Polarity: Vertical

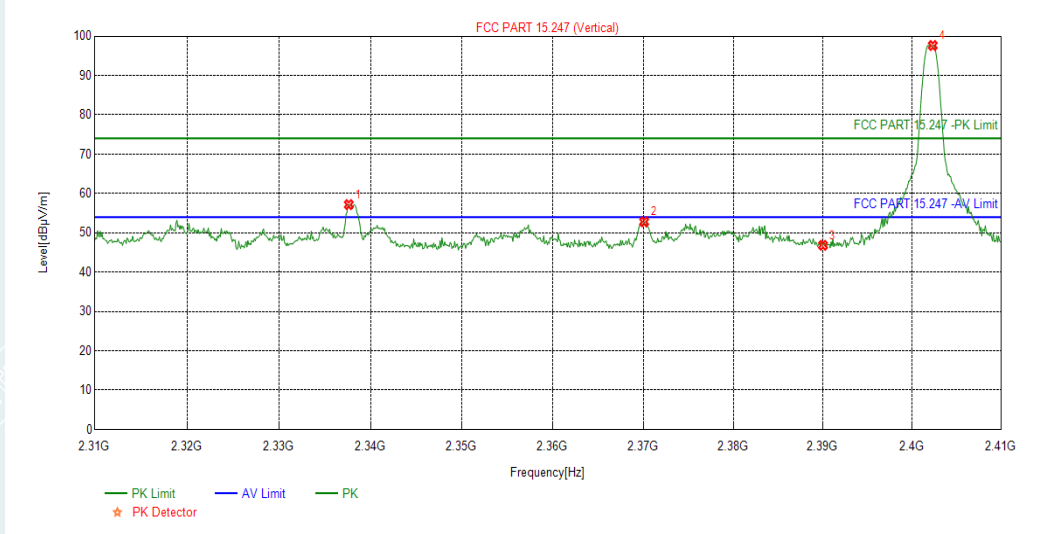

Detector mode: Average

Polarity: Vertical

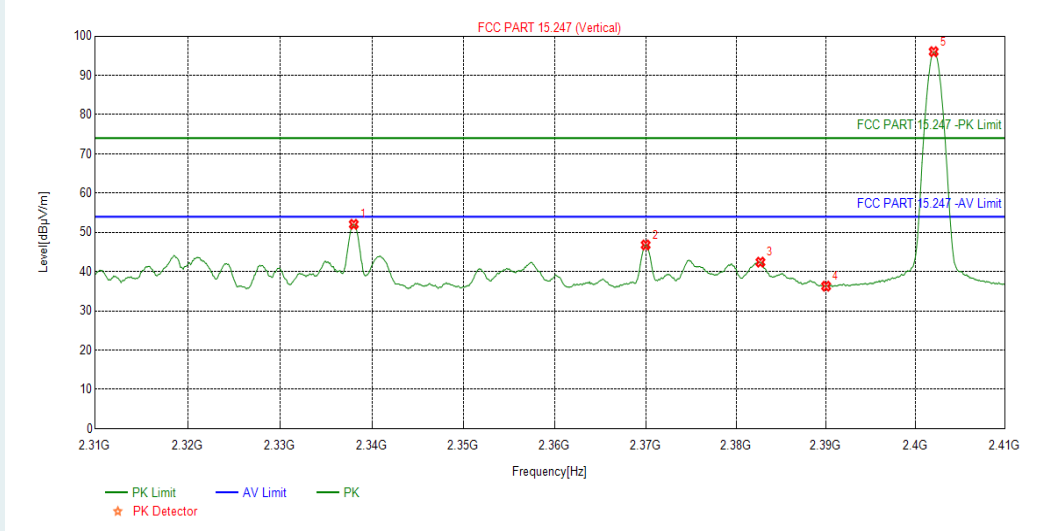

N o.	Frequency MHz	Factor dB	Result dBµV/m	Limit dBµV/m	Margin dB	Remark	Pole
1	2337.6000	2.35	57.17	74.00	---	Peak	Vertical
2	2370.1000	2.57	52.79	74.00	---	Peak	Vertical
3	2390.0000	2.81	46.82	74.00	---	Peak	Vertical
4	2402.3000	2.92	97.62	74.00	-23.62	Peak	Vertical
1	2338.0000	2.35	52.05	54.00	---	Average	Vertical
2	2370.0000	2.56	46.79	54.00	---	Average	Vertical
3	2382.7000	2.72	42.41	54.00	---	Average	Vertical
4	2390.0000	2.81	36.29	54.00	---	Average	Vertical
5	2402.0000	2.92	96.03	54.00	-42.03	Average	Vertical

Lowest Channel

Detector mode: Peak

Polarity: Horizontal

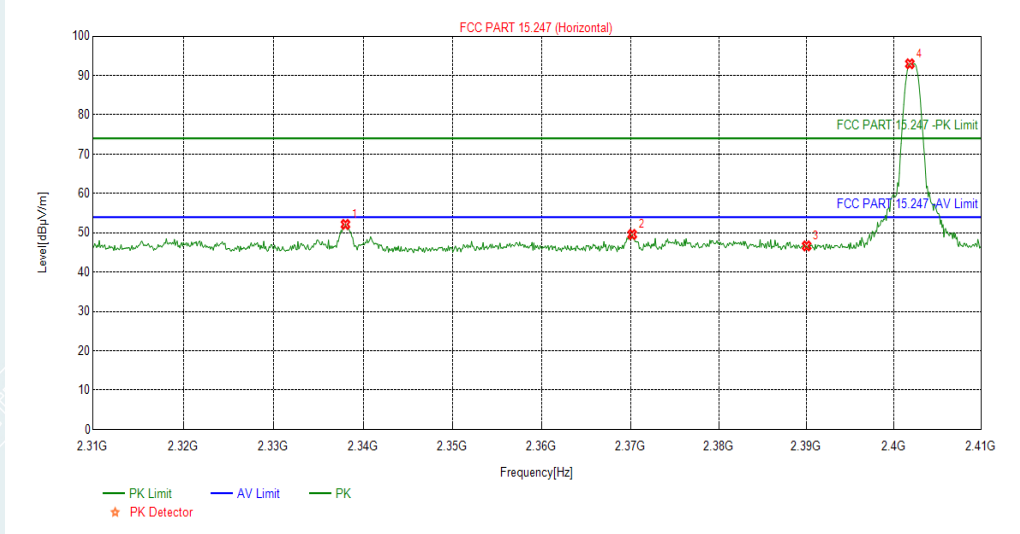

Detector mode: Average

Polarity: Horizontal

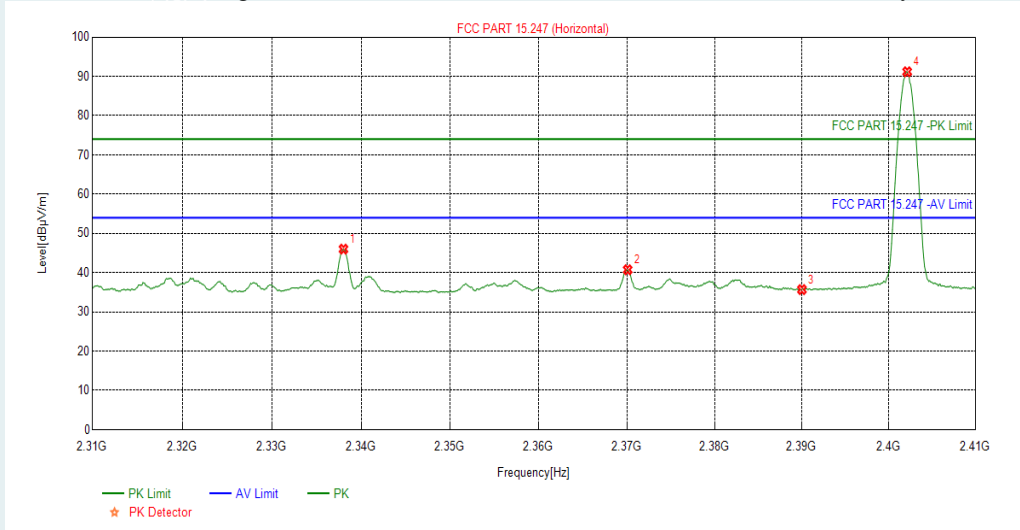

No.	Frequency MHz	Factor dB	Result dBuV/m	Limit dBuV/m	Margin dB	Remark	Pole
1	2338.0000	2.35	52.14	74.00	21.86	Peak	Horizontal
2	2370.2000	2.57	49.58	74.00	24.42	Peak	Horizontal
3	2390.0000	2.81	46.66	74.00	27.34	Peak	Horizontal
4	2401.8000	2.92	92.96	74.00	-18.96	Peak	Horizontal
1	2338.0000	2.35	45.99	54.00	8.01	Average	Horizontal
2	2370.1000	2.57	40.73	54.00	13.27	Average	Horizontal
3	2390.0000	2.81	35.67	54.00	18.33	Average	Horizontal
4	2402.1000	2.92	91.16	54.00	-37.16	Average	Horizontal

Highest channel

Detector mode: Peak

Polarity: Vertical

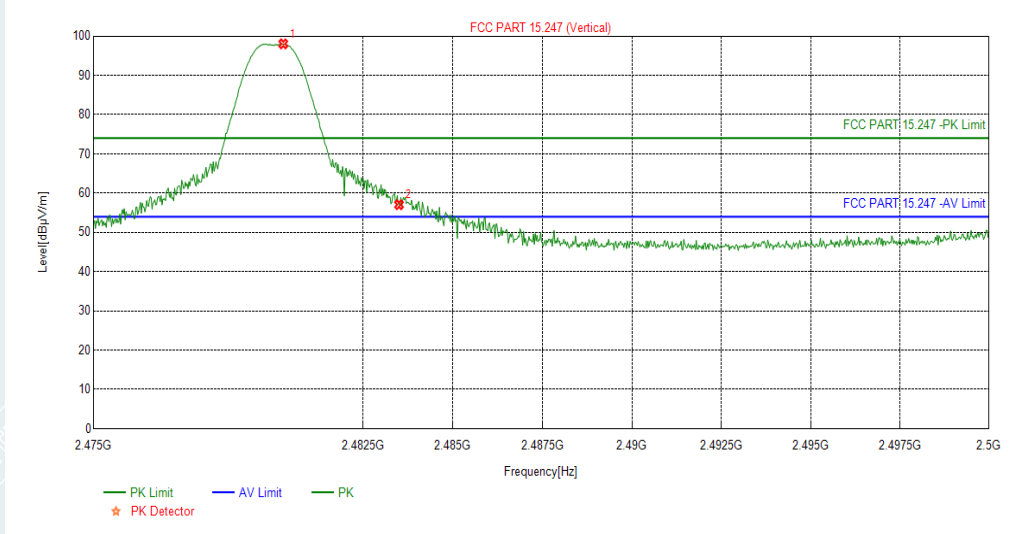

Detector mode: Average

Polarity: Vertical

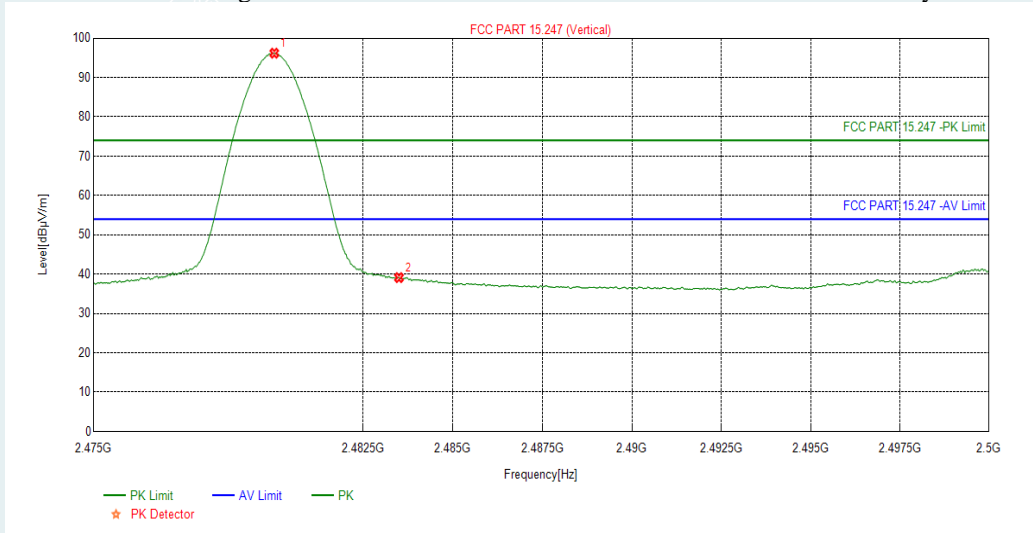

No.	Frequency MHz	Factor dB	Result dBuV/m	Limit dBuV/m	Margin dB	Remark	Pole
1	2480.2750	2.84	98.02	74.00	-24.02	Peak	Vertical
2	2483.5000	2.85	57.05	74.00	16.95	Peak	Vertical
1	2480.0250	2.84	96.18	54.00	-42.18	Average	Vertical
2	2483.5000	2.85	39.11	54.00	14.89	Average	Vertical

Highest channel

Detector mode: Peak

Polarity: Horizontal

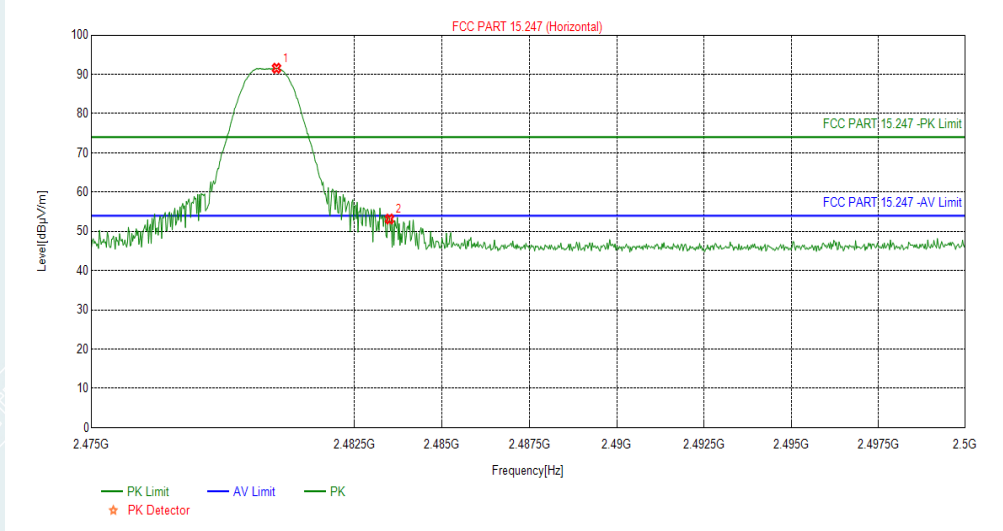

Detector mode: Average

Polarity: Horizontal

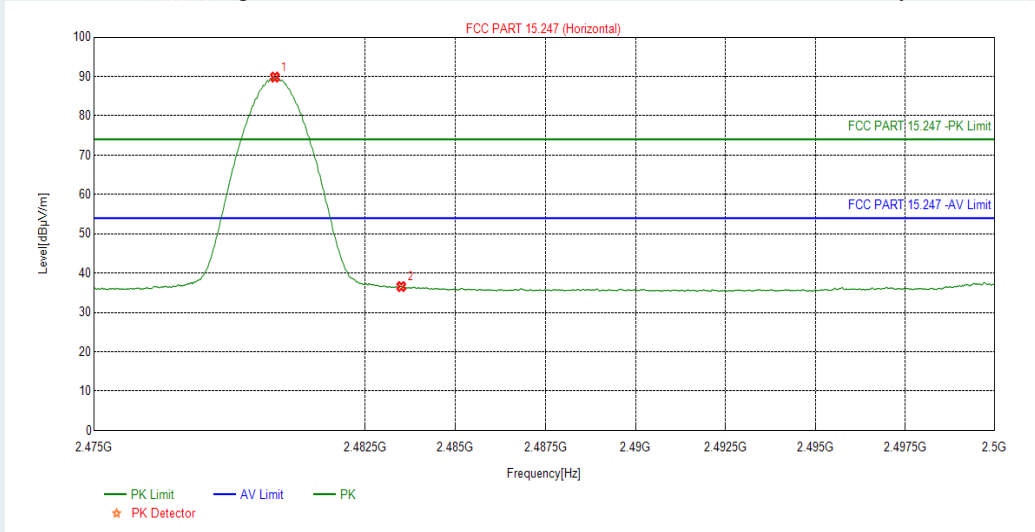

No.	Frequency MHz	Factor dB	Result dBµV/m	Limit dBµV/m	Margin dB	Remark	Pole
1	2480.2750	2.84	91.56	74.00	-17.56	Peak	Horizontal
2	2483.5000	2.85	53.14	74.00	20.86	Peak	Horizontal
1	2480.0000	2.84	89.84	54.00	-35.84	Average	Horizontal
2	2483.5000	2.85	36.58	54.00	17.42	Average	Horizontal

Remark: Max field strength in 3m distance. No any other emission which falls in restricted bands can be detected and be reported.

APPENDIX A: PHOTOGRAPH OF THE TEST ARRANGEMENT RSE (Below 1GHz)

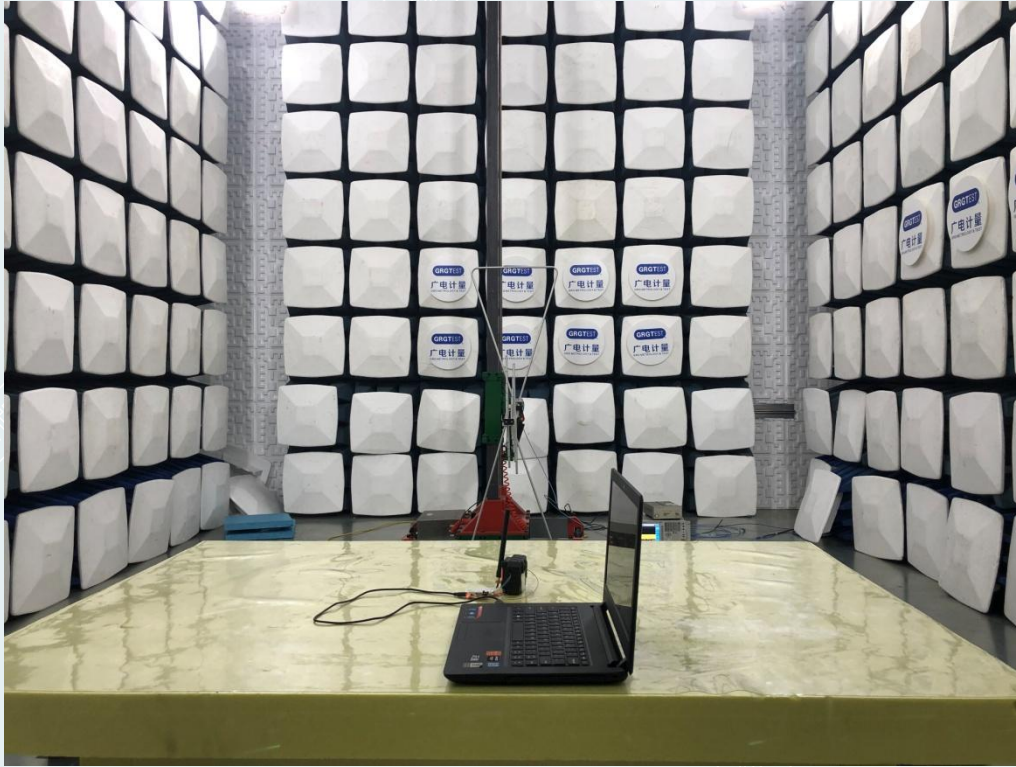

RSE (Above 1GHz)

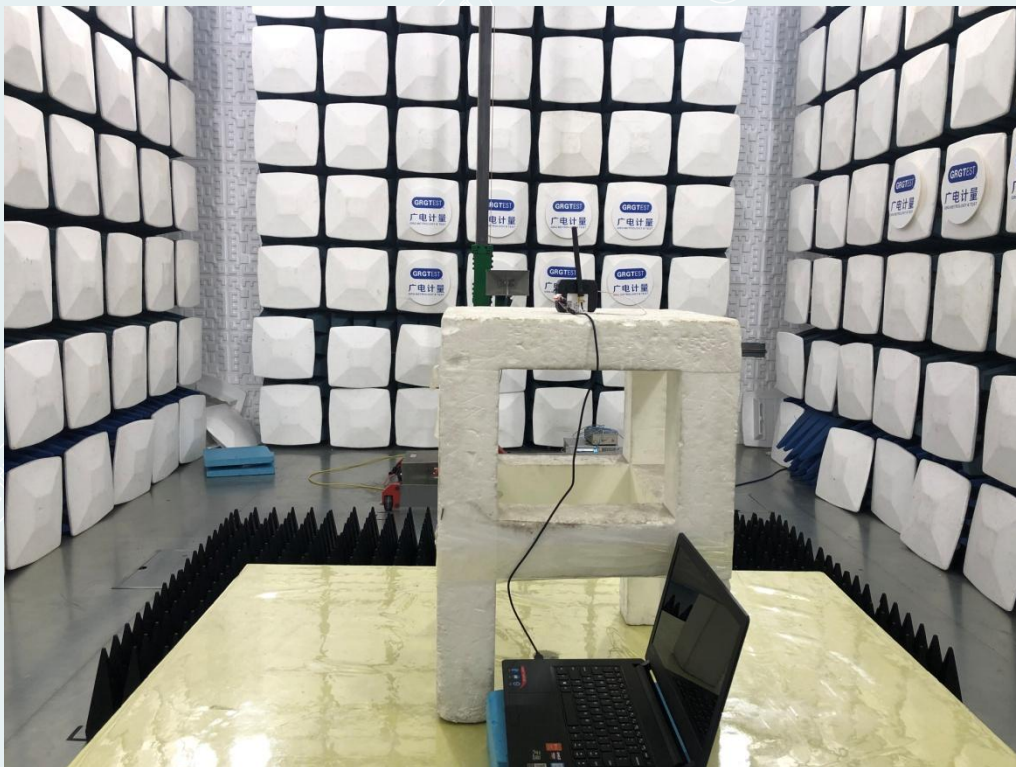

-----This is the last page of the report. -----