



TEST REPORT

GRGTEST

Verified code: 551831

Report No.:	E20191108785501-5	Application No.:	E20191108785501
Client:	K-Mark Industrial LTD		
Address:	Flat A,7/F.,Mai On Ind.Bldg.,17-21,Kung Yip St.,Kwai Chung,Hong Kong		
Sample Description:	Remote Feeder Activator		
Model:	AH-RMT		
FCC ID	VEPGL-AHACTIVATOR		
Test Location:	GRG METROLOGY & TEST (SHENZHEN) CO., LTD		
Test Specification:	FCC 47 CFR Part 15 Subpart C		
Test Date:	2019/12/14 to 2019/12/16		
Issue Date:	2019/12/29		
Test Result:	PASS		
Prepared By: Test Engineer <i>Wu Haoping</i>	Reviewed By: Technical Manager <i>Wu Chengrong</i>	Approved By: Manager <i>Zhu Yan</i>	
Other Aspects:			
Note: /			
Abbreviations: ok / P = passed; fail / F = failed; n.a. / N = not applicable;			
The test result in this test report refers exclusively to the presented test sample. This report shall not be reproduced except in full, without the written approval of GRGT.			

DIRECTIONS OF TEST

1. This company carries out test task according to the national regulation of verifications which can be traced to National Primary Standards and BIPM.
2. The test report merely corresponds to the test sample. It is not permitted to copy extracts of these test result without the written permission of the test laboratory.
3. If there is any objection concerning the test, the client should inform the laboratory within 15 days from the date of receiving the test report.

TABLE OF CONTENTS

1. TEST RESULT SUMMARY	4
2. GENERAL DESCRIPTION OF EUT.....	5
2.1. APPLICANT	5
2.2. MANUFACTURER	5
2.3. FACTORY	5
2.4. BASIC DESCRIPTION OF EQUIPMENT UNDER TEST	5
3. LABORATORY AND ACCREDITATIONS	6
3.1. LABORATORY	6
3.2. ACCREDITATIONS.....	6
3.3. MEASUREMENT UNCERTAINTY	6
4. LIST OF USED TEST EQUIPMENT AT GRGT.....	7
5. RADIATED SPURIOUS EMISSIONS	8
5.1. LIMITS.....	8
5.2. TEST PROCEDURES.....	8
5.3. TEST SETUP	9
5.4. DATA SAMPLE	10
5.5. TEST RESULTS	11
6. 20DB BANDWIDTH.....	15
6.1. LIMITS.....	15
6.2. TEST PROCEDURES.....	15
6.3. TEST SETUP	15
6.4. TEST RESULTS	15
7. TRANSMISSION TIME	16
7.1. LIMITS.....	16
7.2. TEST PROCEDURES.....	16
7.3. TEST SETUP	16
7.4. TEST RESULTS	16
APPENDIX A: PHOTOGRAPH OF THE TEST ARRANGEMENT.....	20

1. TEST RESULT SUMMARY

Section B of FCC Part 15.231			
Standard	Item	Limit / Severity	Result
Part 15,Subpart C (15.231)	Conducted Emissions	§15.203	N/A ¹⁾
	Transmission Time	§15.231 §15.231(a) (3)	PASS
	20DB Bandwidth	§15.231 (c)	PASS
	Radiated Spurious Emission	§15.231(b)	PASS

Note. 1: The EUT received DC power supplied by battery.

2. GENERAL DESCRIPTION OF EUT

2.1. APPLICANT

Name: K-Mark Industrial LTD
Address: Flat A,7/F.,Mai On Ind.Bldg.,17-21,Kung Yip St.,Kwai Chung,Hong Kong

2.2. MANUFACTURER

Name: K-Mark Industrial LTD
Address: Flat A,7/F.,Mai On Ind.Bldg.,17-21,Kung Yip St.,Kwai Chung,Hong Kong

2.3. FACTORY

Factory
Name : K-Mark Industrial (Shenzhen) LTD
Address : 43 Jinshi Road, niuhu Guangpei community, Guanlan street, Longhua District, Shenzhen

2.4. BASIC DESCRIPTION OF EQUIPMENT UNDER TEST

Equipment: Remote Feeder Activator
Model No.: AH-RMT
Adding Model /
Trade Name: GSM LLC
Power supply DC3V Supply by the battery
Frequency Range 433.92MHz
Max Antenna gain: Antenna with 3dBi gain(Max)
Sample submitting way : Provided by customer Sampling
Type of Modulation: FSK
Temperature Range: -20°C ~60+ °C
Hardware Version: V2.0
Software Version: V5.0
Note: /

3. LABORATORY AND ACCREDITATIONS

3.1. LABORATORY

The tests and measurements refer to this report were performed by EMC Laboratory of GRG METROLOGY & TEST (SHENZHEN) CO., LTD

Addr.: No.1301 Guanguang Road Xinlan Community, Guanlan Street, Longhua District Shenzhen, 518110, People's Republic of China

Telephone: +86-755-61180008

Fax: /

3.2. ACCREDITATIONS

A2LA	Certificate Number 2861.01
------	----------------------------

3.3. MEASUREMENT UNCERTAINTY

Where relevant, the following measurement uncertainty levels have been estimated for tests performed on the EUT as specified in CISPR 16-4-2:

Measurement		Frequency	Uncertainty
Radiated Emission	Horizontal	30MHz~1000MHz	4.8dB
		1GHz~26.5GHz	5.8dB
	Vertical	30MHz~1000MHz	4.8dB
		1GHz~26.5GHz	5.9dB

This uncertainty represents an expanded uncertainty factor of $k=2$.

4. LIST OF USED TEST EQUIPMENT AT GRGT

Name of Equipment	Manufacturer	Model	Serial Number	Calibration Due
Radiated Spurious Emission& Restricted bands of operation				
Spectrum analyzer	Agilent	N9020A	MY50510140	2020/01/09
EMI TEST Receiver	R&S	ESCI	100088	2020/11/27
EXA signal analyzer	Agilent	N9010A	MY52221469	2020/01/10
Bilog Antenna	Schwarzbeck	VULB 9160	VULB9160-34 01	2020/11/27
Horn Antenna	Schwarzbeck	BBHA9120	D286	2020/11/27
Amplifier	EM Electronics Corporation	EM330	N/A	2020/04/12
High Noise Amplifier	Agilent	8449B	3008A02060	2020/11/18
Test SW	FARAD	EZ-EMC/ CCS-3A1		
20 dB Bandwidth & Transmission Time				
EXA signal analyzer	Agilent	N9010A	MY52221469	2020/01/10
Transmission Time				
EXA signal analyzer	Agilent	N9010A	MY52221469	2020/01/10
Bilog Antenna	Schwarzbeck	VULB 9160	VULB9160-34 01	2020/11/27
Amplifier	EM Electronics Corporation	EM330	N/A	2020/04/12

5. RADIATED SPURIOUS EMISSIONS

5.1. LIMITS

§15.231(b) In addition to the provisions of §15.205, the field strength of emissions from intentional radiators operated under this section shall not exceed the following:

Fundamental frequency (MHz)	Field strength of fundamental (microvolts/meter)	Field strength of spurious emission (microvolts/meter)
40.66-40.70	2,250	225
70-130	1,250	125
130-174	¹ 1,250 to 3,750	¹ 125 to 375
174-260	3,750	375
260-470	¹ 3,750 to 12,500	¹ 375 to 1,250
Above 470	12,500	1,250

1. ** linear interpolations

[Where F is the frequency in MHz, the formulas for calculating the maximum permitted fundamental field strengths are as follows: for the band 130-174 MHz, uV/m at 3 meters = 56.81818(F) - 6136.3636; for the band 260-470 MHz, uV/m at 3 meters = 41.6667(F) - 7083.3333. The maximum permitted unwanted emission level is 20 dB below the maximum permitted fundamental level.]

§15.231(b)(3) The limits on the field strength of the spurious emissions in the above table are based on the fundamental frequency of the intentional radiator. Spurious emissions shall be attenuated to the average (or, alternatively, CISPR quasi-peak) limits shown in this table or to the general limits shown in §15.209, whichever limit permits a higher field strength.

Frequency (MHz)	Quasi-peak(μV/m)	Measurement distance(m)	Quasi-peak(dBμV/m)@distance 3m
0.009-0.490	2400/F(kHz)	300	53.8~88.5
0.490-1.705	24000/F(kHz)	30	43~53.8
1.705-30.0	30	30	49.5
30 ~ 88	100	3	40
88~216	150	3	43.5
216 ~ 960	200	3	46
Above 960	500	3	54

NOTE: (1) The lower limit shall apply at the transition frequencies.

5.2. TEST PROCEDURES

- 1) The EUT was placed on the top of a rotating table 0.8 meters (for below 1GHz) / 1.5 meters (for above 1GHz) above the ground at a 3 meters semi-anechoic chamber. The table was rotated 360 degrees to determine the position of the highest radiation.
- 2) The EUT was set 3 meters away from the interference-receiving antenna, which was mounted on the top of a variable-height antenna tower.
- 3) Height of receiving antenna is varied from one meter to four meters above the ground to determine the maximum value of the field strength. Both horizontal and vertical polarizations of the antenna are set to make the measurement.

- 4) The test-receiver system was set to Peak Detect Function and Specified Bandwidth with Maximum Hold Mode.
- 5) The test-receiver system was set to Peak Detect Function and Specified Bandwidth with Maximum Hold Mode.
- 6) If the emission level of the EUT in peak mode was lower than the limit specified, then testing could be stopped and the peak values of the EUT would be reported.
Otherwise the emissions would be re-tested one by one using peak, quasi-peak or average method as specified and then reported in a data sheet.

5.3. TEST SETUP

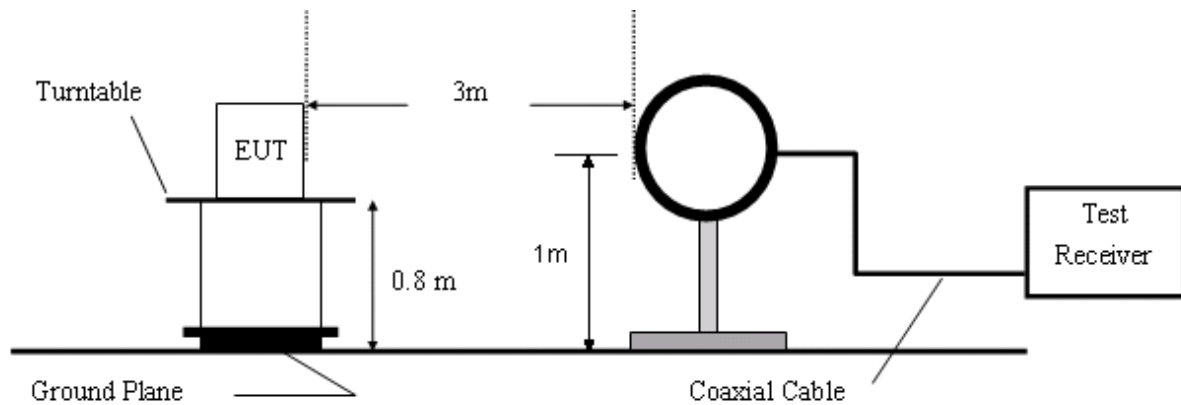

Figure 1. 9KHz to 30MHz radiated emissions test configuration

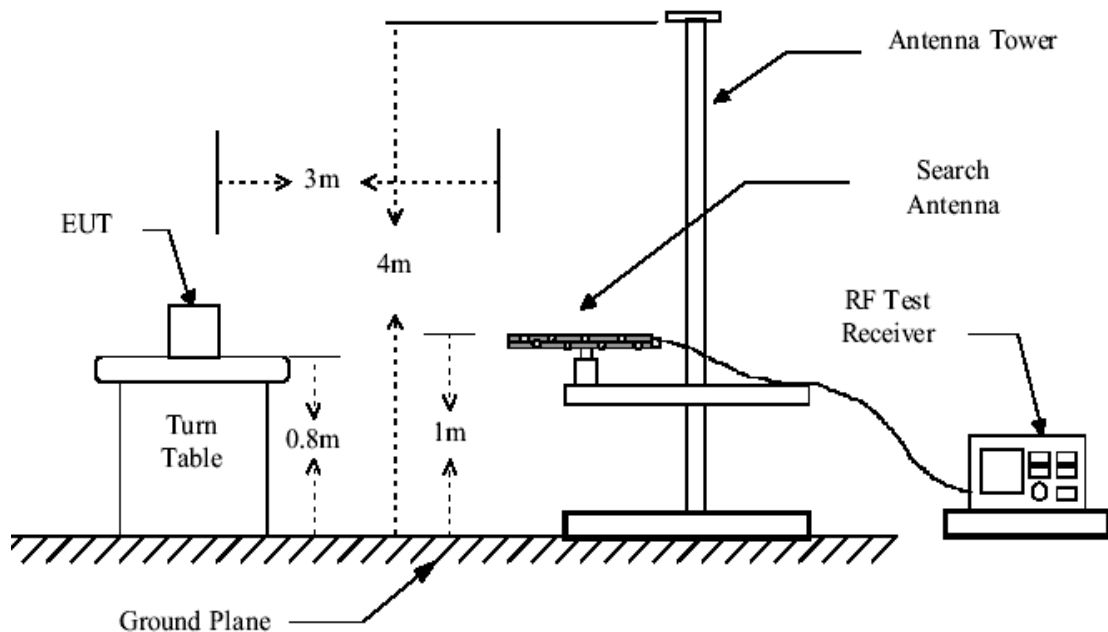

Figure 2. 30MHz to 1GHz radiated emissions test configuration

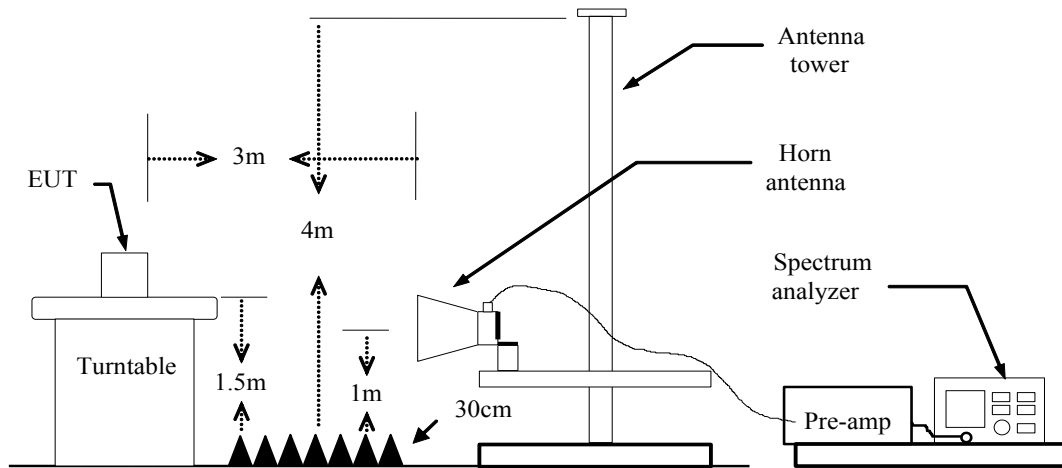

Figure 3. Above 1GHz radiated emissions test configuration

5.4. DATA SAMPLE

Below 1GHz

Frequency (MHz)	Reading (dBuV)	Correction Factor (dB/m)	Result (dBuV/m)	Limit (dBuV/m)	Margin (dB)	Antenna Pole (V/H)	Remark
XXX.XXXX	37.47	-16.41	21.06	40.00	-18.94	V	QP

Above 1GHz

Frequency (MHz)	Reading (dBuV)	Correction Factor (dB/m)	Result (dBuV/m)	Limit (dBuV/m)	Margin (dB)	Antenna Pole (V/H)	Remark
XXXX.XXXX	55.54	4.56	60.10	74.00	-13.90	V	Peak
XXXX.XXXX	29.66	4.56	34.22	54.00	-19.78	V	AVG

- Frequency (MHz) = Emission frequency in MHz
- Reading (dBuV) = Uncorrected Analyzer / Receiver reading
- Correction Factor (dB/m) = Antenna factor + Cable loss – Amplifier gain
- Result (dBuV/m) = Reading (dBuV) + Corr. Factor (dB/m)
- Limit (dBuV/m) = Limit stated in standard
- Margin (dB) = Result (dBuV/m) – Limit (dBuV/m)
- Q.P. = Quasi-peak Reading
- Peak = Peak Reading
- AVG = Average Reading

5.5. TEST RESULTS

For 9 kHz to 30MHz

The amplitude of spurious emissions which are attenuated by more than 20dB below the permissible value has no need to be reported.

Mode: TX

Test channel (433.92 MHz)

Date: 2019/12/14

No.	Frequency (MHz)	Reading (dBuV/m)	Correct Factor(dB/m)	Result (dBuV/m)	Limit (dBuV/m)	Margin (dB)	Remark	Pole
1	433.9200	78.31	-22.29	56.02	100.83	-44.81	peak	Vertical
2	433.9200	72.66	-22.29	50.37	80.83	-30.46	AVG	Vertical
3	581.9300	36.98	-19.22	17.76	46.00	-28.24	peak	Vertical
4	628.4900	36.39	-18.24	18.15	46.00	-27.85	peak	Vertical
5	711.9100	36.18	-17.15	19.03	46.00	-26.97	peak	Vertical
6	766.2300	37.51	-17.79	19.72	46.00	-26.28	peak	Vertical
7	867.8400	40.31	-16.01	24.30	80.83	-56.53	peak	Vertical
8	867.8400	34.66	-16.01	18.65	60.83	-42.18	AVG	Vertical
9	307.4200	37.44	-25.81	11.63	46.00	-34.37	peak	Horizontal
10	342.3400	38.08	-24.73	13.35	46.00	-32.65	peak	Horizontal
11	433.5200	90.51	-22.29	68.22	100.83	-32.61	peak	Horizontal
12	433.5200	85.16	-22.29	62.57	80.83	-18.26	AVG	Horizontal
13	548.9500	35.71	-20.07	15.64	46.00	-30.36	peak	Horizontal
14	680.8700	35.77	-17.30	18.47	46.00	-27.53	peak	Horizontal
15	867.8400	50.29	-15.99	34.30	80.83	-46.53	peak	Horizontal
16	867.8400	44.64	-15.99	28.65	60.83	-32.18	AVG	Horizontal

Vertical

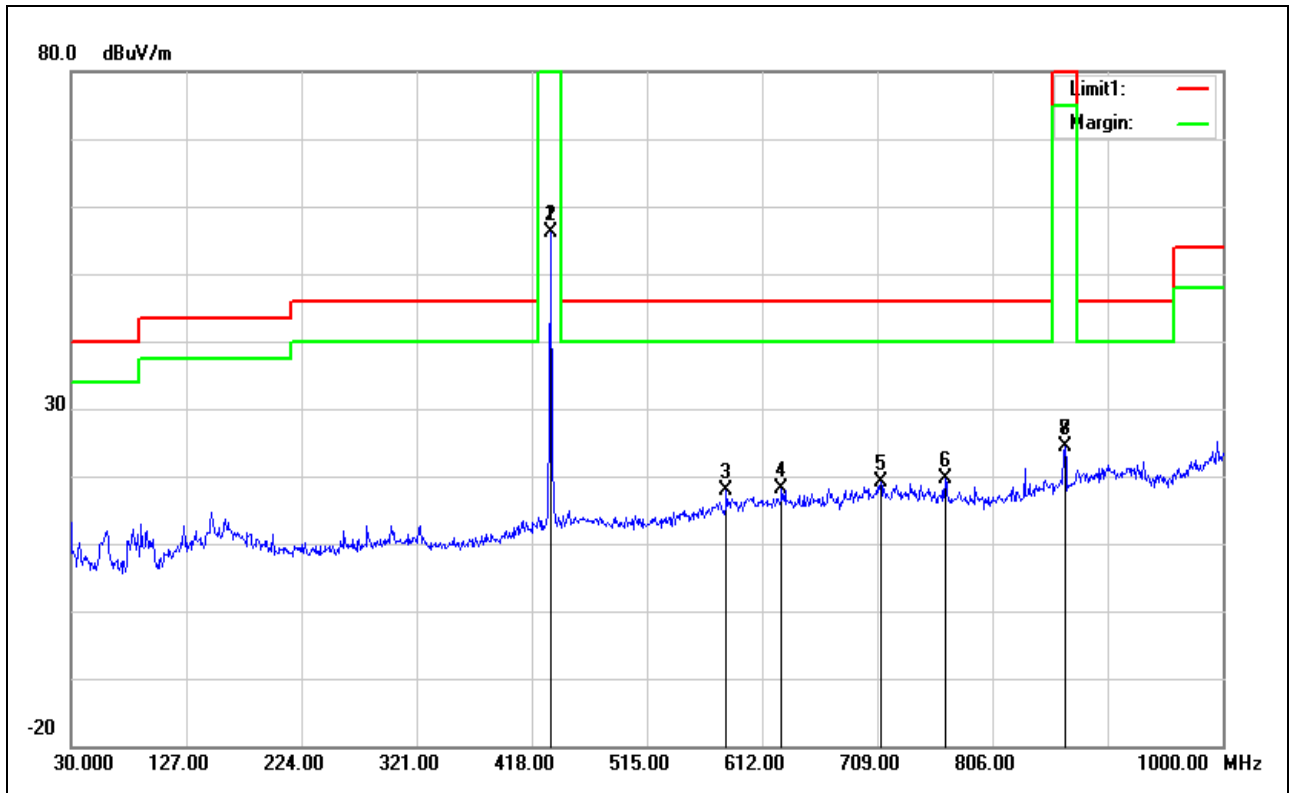

Horizontal

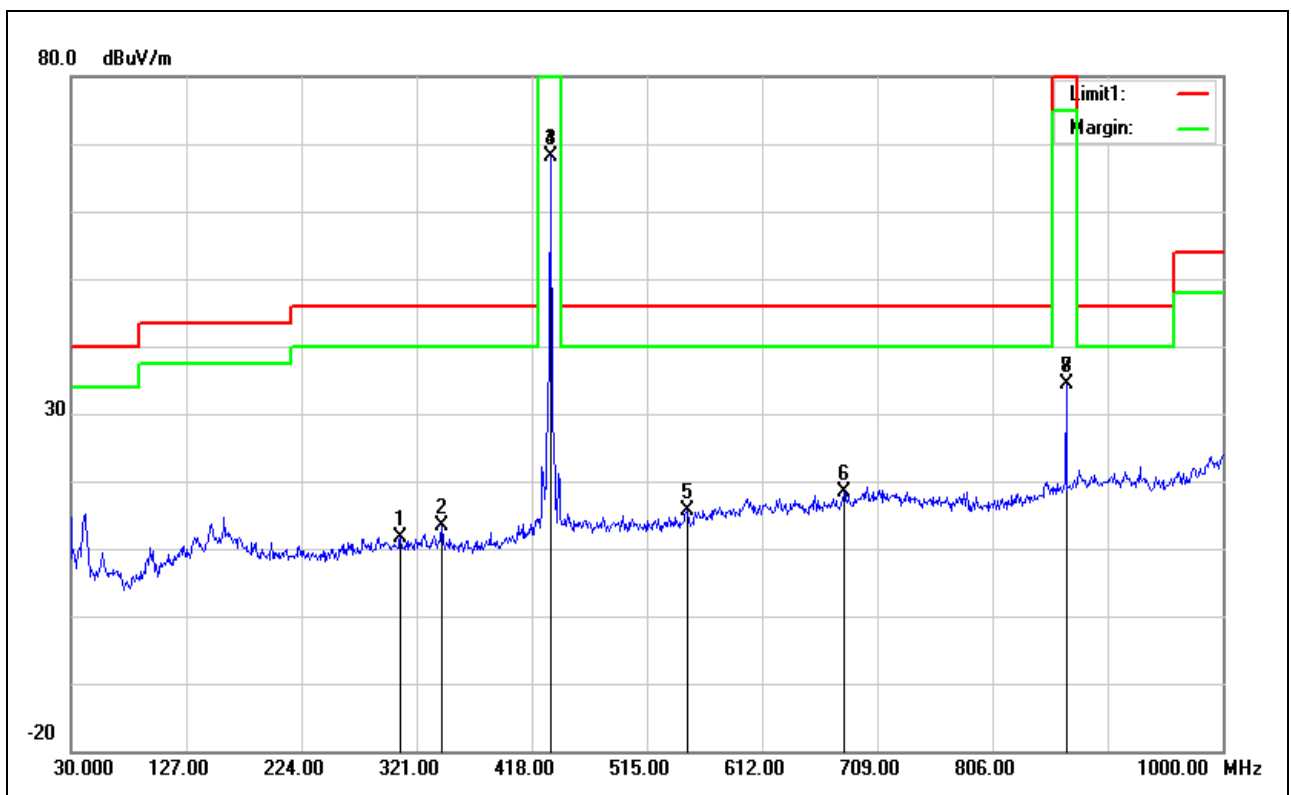

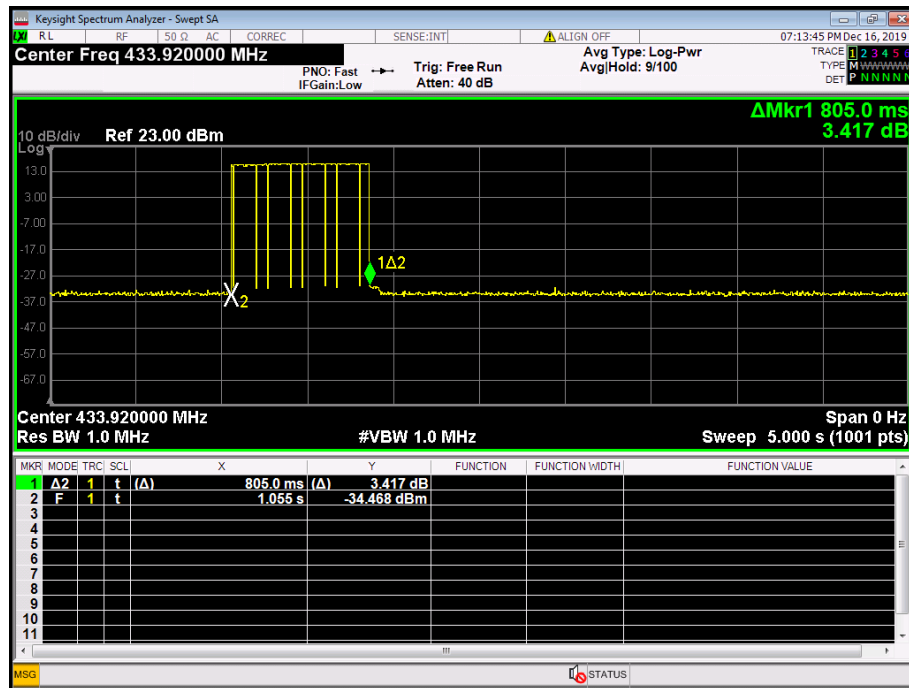

Fundamental:

Frequency	Reading	Correct	Result	Limit	Margin	Antenna Pole(V/H)	Remark
(MHz)	(dBuV/m)	Factor(dB/m)	(dBuV/m)	(dBuV/m)	(dB)		
433.9200	78.31	-22.29	56.02	100.83	-44.81	V	peak
433.9200	72.66	-22.29	50.37	80.83	-30.46	V	AVG
433.9200	90.51	-22.29	68.22	100.83	-32.61	H	peak
433.9200	85.16	-22.29	62.57	80.83	-18.26	H	AVG

Remark:

1. $AVG = Peak + 20 \log(Duty\ Cycle)$
2. Duty Cycle Correction Factor: $20 \log(Duty\ Cycle) = -5.65$
3. Duty Cycle = $On\ time / Total\ time = 52.2 / 100 = 52.2\%$

Emission above 1GHz:

Mode: TX

Test channel (433.92 MHz)

Date: 2019/12/14

No.	Frequency (MHz)	Reading (dBuV/m)	Correct Factor(dB/m)	Result (dBuV/m)	Limit (dBuV/m)	Margin (dB)	Remark	Pole
1	1780.000	52.52	-3.67	48.85	74.00	-25.15	peak	Vertical
2	2370.000	43.70	-1.53	42.17	74.00	-31.83	peak	Vertical
3	2770.000	42.48	-0.08	42.40	74.00	-31.60	peak	Vertical
4	3040.000	48.94	0.92	49.86	74.00	-24.14	peak	Vertical
5	3040.000	43.29	0.92	44.21	54.00	-9.79	AVG	Vertical
6	3375.000	41.39	0.92	42.31	74.00	-31.69	peak	Vertical
7	4545.000	40.25	2.52	42.77	74.00	-31.23	peak	Vertical
8	1775.000	49.38	-5.25	44.13	74.00	-29.87	peak	Horizontal
9	2170.000	54.70	-3.76	50.94	74.00	-23.06	peak	Horizontal
10	2605.000	44.12	-2.83	41.29	74.00	-32.71	peak	Horizontal
11	3040.000	59.11	-1.27	57.84	74.00	-16.16	peak	Horizontal
12	3040.000	53.46	-1.27	52.19	54.00	-1.81	AVG	Horizontal
13	3875.000	40.91	-0.36	40.55	74.00	-33.45	peak	Horizontal
14	4330.000	39.86	0.56	40.42	74.00	-33.58	peak	Horizontal

6. 20DB BANDWIDTH

6.1. LIMITS

§15.231 (c) The bandwidth of the emission shall be no wider than 0.25% of the center frequency for devices operating above 70 MHz and below 900 MHz. For devices operating above 900 MHz, the emission shall be no wider than 0.5% of the center frequency. Bandwidth is determined at the points 20 dB down from the modulated carrier.

6.2. TEST PROCEDURES

- 1) Set resolution bandwidth (RBW) = 10kHz. Set the video bandwidth (VBW) ≥ 3 x RBW. Detector = Peak. Trace mode = max hold. Sweep = auto couple. Allow the trace to stabilize, record 20dB bandwidth value.
- 2) Repeat above procedures until all frequencies measured were complete.

6.3. TEST SETUP



6.4. TEST RESULTS

Test mode:

Channel	Frequency (MHz)	Bandwidth (kHz)	Limit (kHz)	Test Result
	433.92	64.38	1084.8	PASS

Test Plot

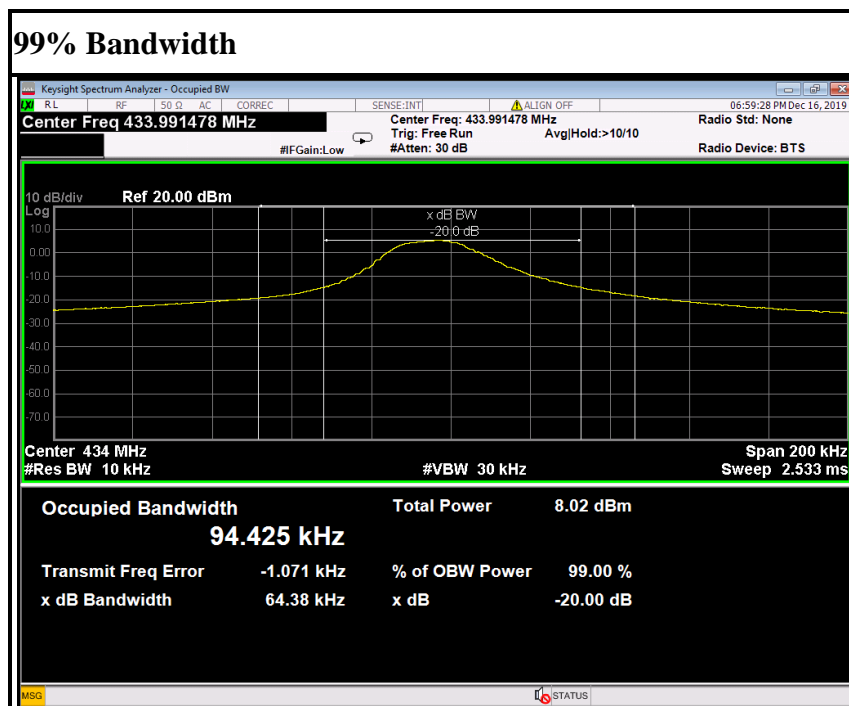

7. TRANSMISSION TIME

7.1. LIMITS

§15.231 (e) (3) Periodic transmissions at regular predetermined intervals are not permitted. However, polling or supervision transmissions, including data, to determine system integrity of transmitters used in security or safety applications are allowed if the total duration of transmissions does not exceed more than two seconds per hour for each transmitter. There is no limit on the number of individual transmissions, provided the total transmission time does not exceed two seconds per hour.

§15.231 (e) devices operated under the provisions of this paragraph shall be provided with a means for automatically limiting operation so that the duration of each transmission shall not be greater than one second and the silent period between transmissions shall be at least 30 times the duration of the transmission but in no case less than 10 seconds.

§15.231 (e) for this periodic operation:

- (1) A manually operated transmitter shall employ a switch that will automatically deactivate the transmitter within not more than 5 seconds of being released.
- (2) A transmitter activated automatically shall cease transmission within 5 seconds after activation.

7.2. TEST PROCEDURES

- 1) The spectrum analyzer resolution bandwidth that is \leq EBW. So we test the Maximum Conducted Output Power — Integrated band power method.
- 2) Set Set the analyzer span = 0Hz. RBW = 100kHz. Set VBW \geq 3 x RBW. Detector = Peak. Sweep = Adjust according to actual conditions.
- 3) Allow the trace to stabilize, record value.

7.3. TEST SETUP

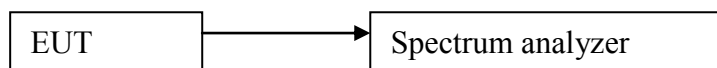

7.4. TEST RESULTS

Test Data

Frequency (MHz)	Transmission Time (s)	Limit (s)	Result
433.92	0.805	5	Pass

Test Plot

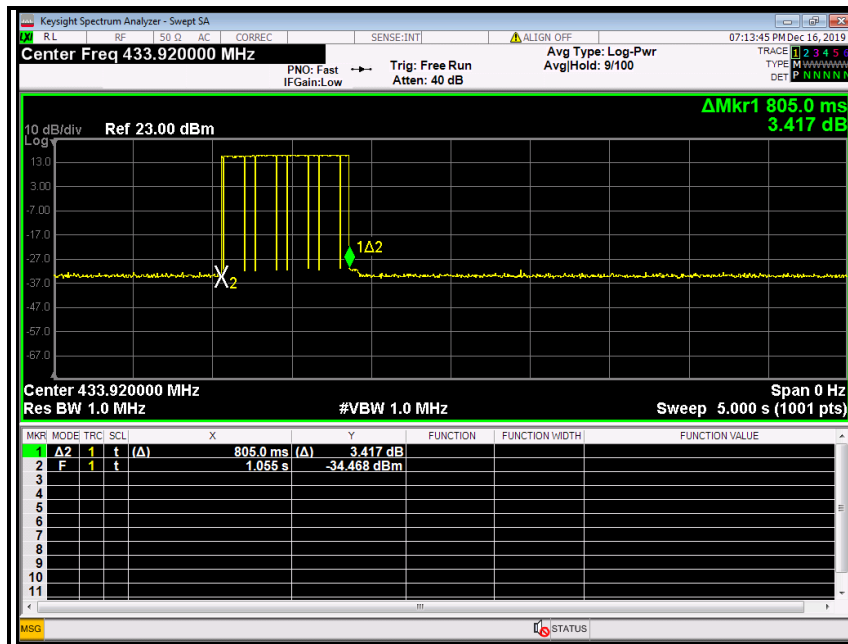

Duty Cycle:

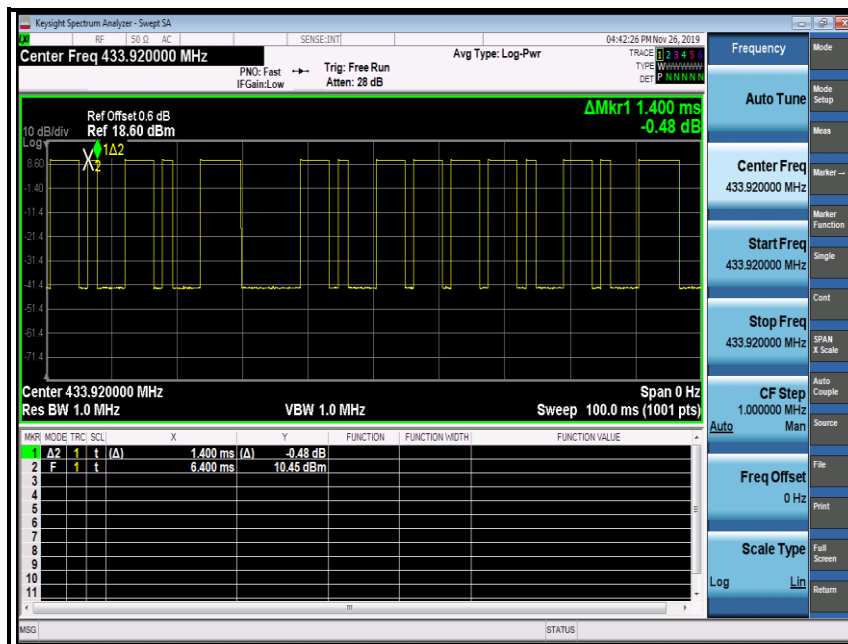
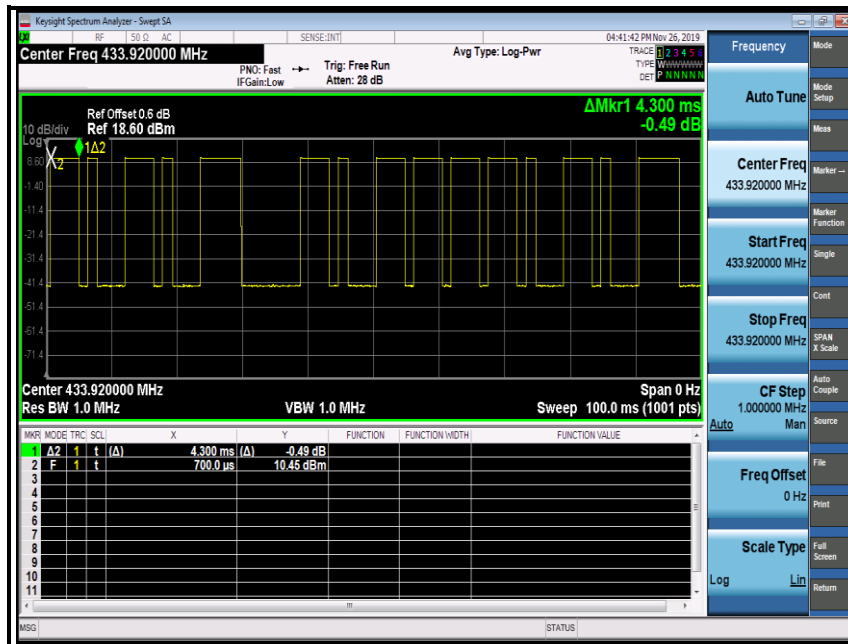

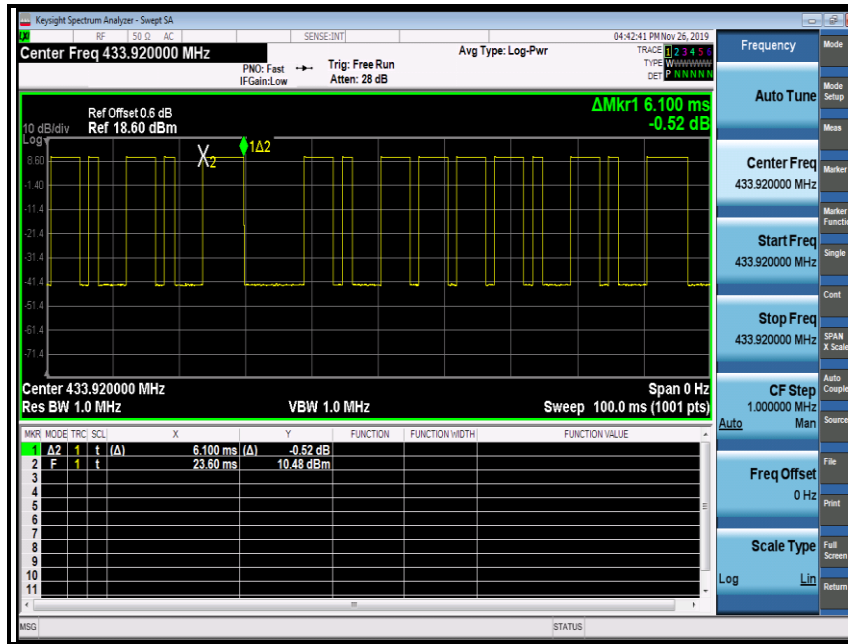

Remark:

1. On time: $4.3*8+1.4*4+6.1*2=52.2\text{ms}$
2. Duty Cycle = On time/Total time = $52.2\text{ms}/100\text{ms}=52.2\%$

APPENDIX A: PHOTOGRAPH OF THE TEST ARRANGEMENT

RSE (Below 1GHz)



RSE (Above 1GHz)

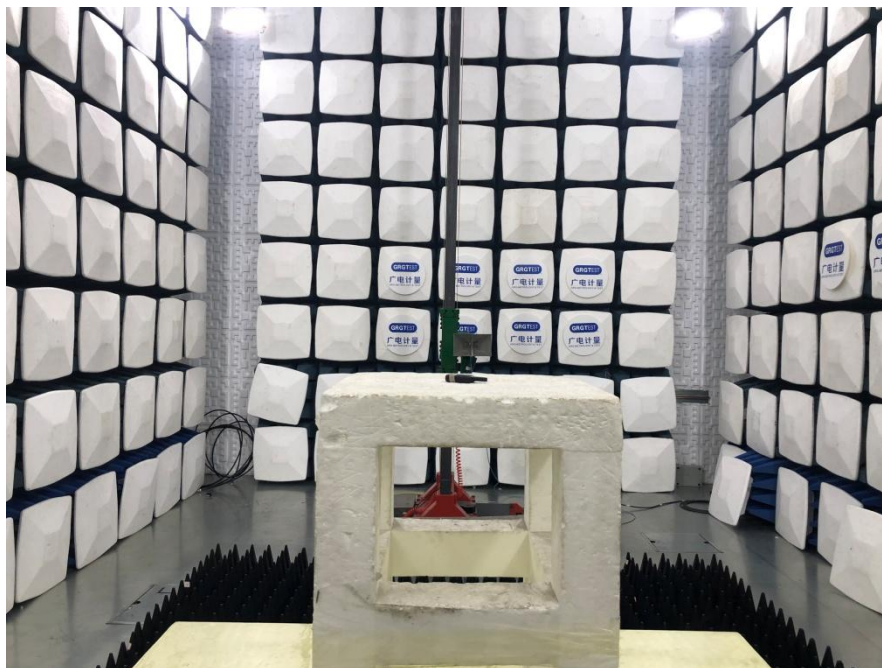

-----This is the last page of the report. -----