

ST ELECTRONICS (SATCOM & SENSOR SYSTEMS) PTE LTD.

K-BAND DOPPLER RF TRANSCEIVER MODULE

Model: DF300-0



05 January 2009

Report No.: SL08101401-STE-003 (15.245) Rev 01
(This report supersedes SL0810401-STE-003 (15.245))



Modifications made to the product : None

This Test Report is Issued Under the Authority of:

	
Dan Corona Test Engineer	Leslie Bai Engineering Reviewer

This test report may be reproduced in full only.
Test result presented in this test report is applicable to the representative sample only.

EMC Test Report

To: FCC Part 15.245

SIEMIC, INC.
Accessing global markets



SIEMIC ACREDITATION DETAILS: A2LA Certificate Number: 2742.01



**THE AMERICAN ASSOCIATION FOR
LABORATORY ACCREDITATION**

ACCREDITED LABORATORY

A2LA has accredited
SIEMIC LABORATORIES
San Jose, CA

for technical competence in the field of
Electrical Testing

This laboratory is accredited in accordance with the recognized International Standard ISO/IEC 17025:2005 *General Requirements for the Competence of Testing and Calibration Laboratories*. This accreditation demonstrates technical competence for a defined scope and the operation of a laboratory quality management system (refer to joint ISO-ILAC-LAF Communiqué dated 18 June 2005).

Presented this 11th day of July 2008.



President
For the Accreditation Council
Certificate Number 2742.01
Valid to September 30, 2010



For the tests or types of tests to which this accreditation applies,
please refer to the laboratory's Electrical Scope of Accreditation.



SIEMIC ACREDITATION DETAILS: FCC Registration No. 783147

FEDERAL COMMUNICATIONS COMMISSION

**Laboratory Division
7435 Oakland Mills Road
Columbia, MD 21046**

December 20, 2007

Registration Number: 783147

SIEMIC Laboratories
2206 Ringwood Avenue,
San Jose, CA 95131

Attention: Leslie Bai

Re: Measurement facility located at San Jose
3 & 10 meter site
Date of Renewal: December 20, 2007

Dear Sir or Madam:

Your request for renewal of the registration of the subject measurement facility has been received. The information submitted has been placed in your file and the registration has been renewed. The name of your organization will remain on the list of facilities whose measurement data will be accepted in conjunction with applications for Certification under Parts 15 or 18 of the Commission's Rules. Please note that the file must be updated for any changes made to the facility and the registration must be renewed at least every three years.

Measurement facilities that have indicated that they are available to the public to perform measurement services on a fee basis may be found on the FCC website www.fcc.gov under E-Filing, OET Equipment Authorization Electronic Filing, Test Firms.

Sincerely,

Phyllis Parrish
Industry Analyst

SIEMIC ACREDITATION DETAILS: Industry of Canada Registration No. 4842-1



May 23rd, 2008

OUR FILE: 46405-4842
Submission No: 126429

Siemic Inc.
2206 Ringwood Ave.
San Jose CA 95131
USA

Attention: Leslie Bai

Dear Sir/Madame:

The Bureau has received your application for the registration / renewal of a 3/10m OATS. Be advised that the information received was satisfactory to Industry Canada. The following number(s) is now associated to the site(s) for which registration / renewal was sought (**4842A-1**). Please reference the appropriate site number in the body of test reports containing measurements performed on the site. In addition, please be informed that the Bureau is now utilizing a **new site numbering scheme** in order to simplify the electronic filing process. Our goal is to reduce the number of secondary codes associated to one particular company. The following changes have been made to your record.

- Your primary code is: **4842**
- The company number associated to the site(s) located at the above address is: **4842A**
- The table below is a summary of the changes made to the unique site registration number(s):

New Site Number	Obsolete Site Number	Description of Site	Expiry Date (YYYY-MM-DD)
4842A-1	4842-1	3m Chamber	2010-05-23

Furthermore, to obtain or renew a unique site number, the applicant shall demonstrate that the site has been accredited to ANSI C63.4-2003 or later. A scope of accreditation indicating the accreditation by a recognized accreditation body to ANSI C63.4-2003 shall be accepted. Please indicate in a letter the previous assigned site number if applicable and the type of site (example: 3 meter OATS or 3 meter chamber). If the test facility is not accredited to ANSI C63.4-2003 or later, the test facility shall submit test data demonstrating full compliance with the ANSI standard. The Bureau will evaluate the filing to determine if recognition shall be granted.

The frequency for re-validation of the test site and the information that is required to be filed or retained by the testing party shall comply with the requirements established by the accrediting organization. However, in all cases, test site re-validation shall occur on an interval not to exceed two years. There is no fee or form associated with an OATS filing. OATS submissions are encouraged to be submitted electronically to the Bureau using the following URL:
http://strategis.ic.gc.ca/epic/internet/inccb-blst.nsf/en/h_t00052e.html.

If you have any questions, you may contact the Bureau by e-mail at certification.bureau@ic.gc.ca
Please reference our file and submission number above for all correspondence.

Yours sincerely,



S. Proulx
Test & Measurement Specialist
Certification and Engineering Bureau
3701 Carling Ave., Building 94
Ottawa, Ontario K2H 8S2



SIEMIC, INC.
Accessing global markets

Title: RF Test Report of ST Electronics (Satcom & Sensor Systems) Pte Ltd.
Model : DF300-0
To FCC 15.245 2008

Serial# SL08101401-STE-003 (15.245) Rev 01
Issue Date 05 January 2009
Page 5 of 35
www.sieminc.com

SIEMIC ACREDITATION DETAILS: Japan VCCI Registration No. 2195



Voluntary Control Council for Interference
by Information Technology Equipment
7F NDA Bldg, 2-3-5, Azabudai,
Minato-Ku, Tokyo, Japan, 108-0041
Tel:+81-3-5575-3138
Fax:+81-3-5575-3137
<http://www.vcci.or.jp>

February 12, 2004

TO: SIEMIC, INC.

Membership NO: 2195

We confirmed your payment for annual membership fee and admission fee. Thank you very much for your remitting.

Please find enclosed VCCI documents. As admission fee and annual membership fee were confirmed, your company registered as VCCI official member.

From now on, it is possible for your company to submit conformity verification report or/and application for registration of measurement facilities.

Please find necessary forms for your submission from VCCI web-site.
www.vcci.or.jp

When you submit conformity verification report, please submit to Ms. Yoko Inagaki / inagaki@vcci.or.jp and application for registration of measurement facilities, please submit to Mr. Masaru Denda / denda@vcci.or.jp

Their address, phone and fax number are absolutely same as I. Please refer address indicated on top right-hand corner of this page.

If you have any other questions regarding membership, feel free to contact me. Thank you very much.

Best Regards,

Naoko Hori (Ms.)
VCCI
hori@vcci.or.jp

Enclosure

情報処理装置等電波障害自主規制協議会 (通称VCCI)

〒108-8841 東京都港区麻布台2-3-5 / ア ビルディング (NDAビル) 7階 Tel:03-5575-3138 Fax:03-5575-3137



SIEMIC ACREDITATION DETAILS: Japan RF Technologies Accreditation No. MRF050927



Certificate

This is to certify that the
Quality Management System
of

SIEMIC , Inc.
2206 Ringwood Avenue
San Jose, California 95131 U.S.A

has been authorized to carry out Japan Specified Radio Equipment test by
order and under supervision of RF Technologies Co., Ltd. according to
Notification No.88 of Radio Law.

An assessment of the laboratory was conducted according to the "Procedure and
Conditions for Appointments of 2.4GHz Band Low power data communications system
that Bluetooth and Wireless LAN test with reference to ISO/IEC 17025
by an RF Technologies Co., Ltd. auditor.

Audit Report No. MRF050927

Kazuyuki Sarashina
Auditor
RF Technologies Co., Ltd.

Toshihiro Ikegami
President
RF Technologies Co., Ltd.

Audit Date
September 27th, 2005

Issued Date
October 5th, 2005

This Certificate is valid until **September 26th 2006** or next schedule audit.

No:006 Registered Certification Body
RF Technologies Co., Ltd.
472, Nippa-cho, Kohoku-ku, Yokohama, 223-0057, Japan



SIEMIC ACREDITATION DETAILS: Korea MIC Lab Code: KR0032

시험기관지정서

Certificate

of Designated Testing Laboratory

지정번호(No.)	: KR0032
시험기관명 <i>(Name of Lab.)</i>	: (주)현대교정인증기술원 <i>(Hyundai Calibration & Certification Technologies Co., Ltd)</i>
주소 <i>(Address)</i>	: 경기도 이천시 부발읍 아미리 산136-1 <i>(137-1, Ami-ri, Ebal-eup, Icheon-si, Kyunggi-Do, Korea)</i> 2206 Ringwood Avenue San Jose, CA, USA.
시험분야 및 범위 <i>(Area & Category)</i>	: 유선(Telecommunication Part) 무선(Radio Communication Part) 전자파장해(EMF) : 미국지사 포함 전자파내성(EMS) : 미국지사 포함 전기안전(Safety) 전자파흡수율(SAR)

위 기관을 정보통신기기시험기관지정및관리등에관한규칙에
 의해 정보통신기기시험기관으로 지정합니다.
This is to certify that
the above mentioned laboratory is designated
as the testing laboratory in accordance with
the Regulations on Designation of Testing Laboratory
for Information and Communication Equipment.

2005년(Year) 7월(Month) 5일(Date)

전파연구소장

Director General of Radio Research Laboratory
Ministry of Information and Communication
Republic of Korea





SIEMIC ACREDITATION DETAILS: Korea CAB ID: US0160



UNITED STATES DEPARTMENT OF COMMERCE
National Institute of Standards and Technology
Gaithersburg, Maryland 20899

April 17, 2006

Mr. Leslie Bai
SIEMIC Laboratories
2206 Ringwood Avenue
San Jose, CA 95131

Dear Mr. Bai:

I am pleased to inform you that your laboratory has been recognized by the Ministry of Information and Communication's Radio Research Laboratory (RRL) under the Asia Pacific Economic Cooperation (APEC) Mutual Recognition Arrangement (MRA). Your laboratory is now designated to act as a Conformity Assessment Body (CAB) under Appendix B, **Phase I Procedures**, of the APEC Tel MRA. The pertinent information about your laboratory's designation is as follows:

CAB Name: **SIEMIC Laboratories**
Identification No.: **US0160**
Scope:

Coverage	Standards	Date of Recognition
Electro Magnetic Interference	1. RRL Notice No. 2005-82: Technical Requirements for Electromagnetic Interference 2. Annex 8(KN-22), RRL Notice No. 2005-131: Conformity Assessment Procedure for Electromagnetic Interference	April 13, 2006
Electro Magnetic Susceptibility	1. RRL Notice No. 2005-130: Technical Requirements for Electromagnetic Susceptibility 2. Annex 1-7(KN-61000-4-2, -4-3, -4-4, -4-5, -4-6, -4-8, -4-11), RRL Notice No. 2005-132: Conformity Assessment Procedure for Electromagnetic Susceptibility	April 13, 2006

You may submit test data to RRL to verify that the equipment to be imported into Korea satisfies the applicable requirements. The designation of your organization will remain in force as long as its accreditation for the designated scope remains valid and comply with the designation requirements.

The names of all recognized CABs will be posted on the NIST website at <http://ts.nist.gov/mra>. If you have any questions please contact Mr. Joginder (Joe) Dhillon at (301) 975-5521. We appreciate your continued interest in our international conformity assessment activities.

Sincerely,

David F. Alderman
Group Leader, Standards Coordination and Conformity Group

cc: Joginder Dhillon





SIEMIC ACREDITATION DETAILS: Taiwan BSMI Accreditation No. SL2-IN-E-1130R



UNITED STATES DEPARTMENT OF COMMERCE
National Institute of Standards and Technology
Gaithersburg, Maryland 20899

May 3, 2006

Mr. Leslie Bai
SIEMIC Laboratories
2206 Ringwood Avenue
San Jose, CA 95131

Dear Mr. Bai:

I am pleased to inform you that your laboratory has been recognized by the Chinese Taipei's Bureau of Standards, Metrology, and Inspection (BSMI) under the Asia Pacific Economic Cooperation (APEC) Mutual Recognition Arrangement (MRA). Your laboratory is now designated to act as a Conformity Assessment Body (CAB) under Appendix B, **Phase I** Procedures, of the APEC Tel MRA. You may submit test data to BSMI to verify that the equipment to be imported into Chinese Taipei satisfies the applicable requirements. The designation of your organization will remain in force as long as its accreditation for the designated scope remains valid and comply with the designation requirements. The pertinent designation information is as follows:

- BSMI number: **SL2-IN-E-1130R** (Must be applied to the test reports)
- U.S Identification No: **US0160**
- Scope of Designation: **CNS 13438**
- Authorized signatory: **Mr. Leslie Bai**

The names of all recognized CABs will be posted on the NIST website at <http://ts.nist.gov/mra>. If you have any questions, please contact Mr. Dhillon at 301-975-5521. We appreciate your continued interest in our international conformity assessment activities.

Sincerely,

David F. Alderman
Group Leader, Standards Coordination and Conformity Group

cc: Jogindar Dhillon

NIST



SIEMIC, INC.
Accessing global markets

Title: RF Test Report of ST Electronics (Satcom & Sensor Systems) Pte Ltd.
Model : DF300-0
To FCC 15.245 2008

Serial# SL08101401-STE-003 (15.245) Rev 01
Issue Date 05 January 2009
Page 10 of 35
www.sieminc.com

SIEMIC ACREDITATION DETAILS: Taiwan NCC CAB ID: US0160



UNITED STATES DEPARTMENT OF COMMERCE
National Institute of Standards and Technology
Gaithersburg, Maryland 20899

August 8, 2006

Mr. Leslie Bai
SIEMIC Laboratories
2206 Ringwood Avenue
San Jose, CA 95131

Dear Mr. Bai:

I am pleased to inform you that SIEMIC Laboratories has been recognized by the Chinese Taipei's National Communications Commission (NCC) under the Asia Pacific Economic Cooperation for Telecommunications and Information, Mutual Recognition Arrangement (APEC Tel MRA). Your laboratory is now designated to act as a Conformity Assessment Body (CAB) under Appendix B, Phase I Procedures, of the APEC Tel MRA.

You may submit test data to NCC to verify that the equipment to be imported into Chinese Taipei satisfies their applicable requirements using the following guidelines:

- Your laboratory's assigned 6-digit U.S. identification number is **US0160**. You should reference this number in your correspondence.
- The scope of designation is limited to **LP0002**. Your designation will remain in force as long as your accreditation remains valid for the scope of designation.

If you have any questions please contact Mr. Jogindar Dhillon via email at dhillon@nist.gov or via fax at 301-975-5414. The names of all recognized laboratories will be posted on the NIST website at <http://ts.nist.gov/mra>. We appreciate your continued interest in our international conformity assessment activities.

Sincerely,

David F. Alderman
Group Leader, Standards Coordination and Conformity Group

cc: Jogindar Dhillon

NIST



SIEMIC ACREDITATION DETAILS: Mexico NOM Recognition



CAMARA NACIONAL
DE LA INDUSTRIA
ELECTRONICA, DE
TELECOMUNICACIONES
E INFORMATICA

Laboratorio Valentin V. Rivero

México D.F. a 18 de octubre de 2008.

**LESLIE BAI
DIRECTOR OF CERTIFICATION
SIEMIC LABORATORIES, INC.
ACCESSING GLOBAL MARKETS
P R E S E N T E**

En contestación a su escrito de fecha 5 de septiembre del año en curso, le comento que estamos muy interesados en su intención de firmar un Acuerdo de Reconocimiento Mutuo, para lo cual adjunto a este escrito encontrara el Acuerdo en idioma inglés y español preferido de los cuales le pido sea revisado y en su caso corregido, para que si este de acuerdo poder firmarlo para mandarlo con las autoridades Mexicanas para su visto bueno y así poder ejercer dicho acuerdo.

Aprovecho este escrito para mencionarle que nuestro intermediario gestor será la empresa Isabel de México, S. A. de C. V., empresa que ha colaborado durante mucho tiempo con nosotros en lo relacionado a la evaluación de la conformidad y que cuenta con amplia experiencia en la gestión de la certificación de cumplimiento con Normas Oficiales Mexicanas de producto en México.

Me despido de usted enviándole un cordial saludo y esperando sus comentarios al Acuerdo que nos ocupa.

Atentamente:

**Ing. Faustino Gómez González
Gerente Técnico del Laboratorio de
CANIETI**



SIEMIC, Inc.
Accessing global markets

Title: RF Test Report of ST Electronics (Satcom & Sensor Systems) Pte Ltd.
Model : DF300-0
To: FCC 15.245 2008

Serial# SL08101401-STE-003 (15.245) Rev 01
Issue Date 05 January 2009
Page 12 of 35
www.sieminc.com

SIEMIC ACREDITATION DETAILS: Hong Kong OFTA Recognition No. D23/16V



Your Ref 來函編號 : D23/16 V
Our Ref 本局編號 :

Telephone 電話 : (852) 2961 6320
Fax No 圖文傳真 : (852) 2838 5004
E-mail 電郵地址 : 20 July 2005

Mr. Leslie Bai
Director of Certification,
SIEMIC Laboratories
2206 Ringwood Avenue
San Jose, California 95131
USA

Dear Mr. Bai,

Application of Recognised Testing Agency (RTA)

Referring your submission of 28 June 2005 in relation to the application of RTA, I am pleased to inform you that OFTA has appointed SIEMIC Laboratories (SIEMIC) as a Recognised Testing Agency (RTA) :

Please note that, under the Hong Kong Telecommunications Equipment Evaluation and Certification (HKTEC) Scheme, SIEMIC is authorized to conduct evaluation tests on telecommunications equipment against the following HKTA specifications :

Scope of recognition (HKTA Specifications) :
1001, 1002, 1004, 1006, 1007, 1008
1010, 1015, 1016
1022, 1026, 1027, 1029
1030, 1031, 1032, 1033, 1034, 1035, 1039
1041, 1042, 1043, 1045, 1047, 1048
2001

You are requested to refer to and comply with the code of practice and guidelines for RTA as given in the Information Note OFTA 1411 "Recognised Testing Agency (RTA) for Conducting Evaluation Test of Telecommunications Equipment", which can be downloaded from OFTA's homepage at <http://www.ofta.gov.hk/tec/information-notes.html>.

If you have any queries, please do not hesitate to contact me.

Yours sincerely,

(K K Sin)
for Director-General
of Telecommunications

Office of the Telecommunications Authority
29/F Wu Chung House 213 Queen's Road East Wan Chai Hong Kong
電訊管理局
香港灣仔皇后大道東 213 號胡忠大廈 29 字樓

<http://www.ofta.gov.hk>

This page has been left blank intentionally.

CONTENTS

1	EXECUTIVE SUMMARY & EUT INFORMATION	16
2	TECHNICAL DETAILS.....	17
3	MODIFICATION	18
4	TEST SUMMARY	19
5	MEASUREMENTS, EXAMINATION AND DERIVED RESULTS.....	20
	ANNEX A. TEST INSTRUMENT & METHOD	27
	ANNEX B EUT AND TEST SETUP PHOTOGRAPHS	31
	ANNEX C. TEST SETUP AND SUPPORTING EQUIPMENT.....	31
	ANNEX D USER MANUAL, BLOCK & CIRCUIT DIAGRAM	35

This page has been left blank intentionally.

1 Executive Summary & EUT information

The purpose of this test programme was to demonstrate compliance of the ST Electronics (Satcom & Sensor Systems) Pte Ltd. Model:DF300-0 against the current Stipulated Standards. The DF300-0 K-Band Doppler RF Transceiver Module have demonstrated compliance with the FCC 15.245 2008.

EUT Information

EUT Description : The DF300-0 series of microwave motion sensor modules are K-Band Bi-static DRO Doppler transceiver fronted module. These modules are designed for speed detection with direction of motion recognition, traffic applications and other innovative ideas.

The module consists of Dielectric Resonator Oscillator (DRO), balanced mixers, and patch antenna, built-in LNA for high sensitivity and a pre-amplifier.

Model No : DF300-0

Serial No : 50810220001

Input Power : 5 VDC

Classification Per Stipulated Test Standard : Field Disturbance Sensor / Device

2 TECHNICAL DETAILS

Purpose	Compliance testing of K-Band Doppler RF Transceiver Module with stipulated standard
Applicant / Client	ST Electronics (Satcom & Sensor Systems) Pte Ltd.
Manufacturer	ST Electronics (Satcom & Sensor Systems) Pte Ltd. 100, Jurong East St. 21, Level 4, ST Electronics Jurong East Building Singapore 609602
Laboratory performing the tests	SIEMIC Laboratories
Test report reference number	SL08101401-STE-003 (15.245) Rev 01
Date EUT received	20 November 2008
Standard applied	FCC 15.245 2008
Dates of test (from – to)	26 & 28 November 2008
No of Units:	2
Equipment Category:	FDS
Trade Name:	ST Electronics (Satcom & Sensor Systems) Pte Ltd.
Model :	DF300-0
RF Operating Frequency (ies)	24.125 GHz
Number of Channels :	1
Modulation :	No Modulation
FCC ID :	VECDF300-0
IC ID :	N/A



SIEMIC, INC.
Accessing global markets

Title: RF Test Report of ST Electronics (Satcom & Sensor Systems) Pte Ltd.
Model : DF300-0
To FCC 15.245 2008

Serial# SL08101401-STE-003 (15.245) Rev 01
Issue Date 05 January 2009
Page 18 of 35
www.siemic.com

3 MODIFICATION

NONE

4 TEST SUMMARY

The product was tested in accordance with the following specifications. All testing has been performed according to below product classification:

Field Disturbance Sensor / Device

Test Results Summary

Test Standard		Description	Pass / Fail
47 CFR Part 15.245: 2008	RSS 210 Issue 7: 2007		
15.203		Antenna Requirement	Pass
15.207(a)		AC Line Conducted Emissions Voltage	Pass
15.245 (b)		Radiated Emissions Carrier Frequency	Pass
15.245(b) (1)		Radiated Emissions Carrier Harmonics	Pass
15.245(b)(3) / 15.209		Out-of-Band Radiated Emissions	Pass
ANSI C63.4: 2003/ RSS-Gen Issue 2: 2007			
PS: All measurement uncertainties are not taken into consideration for all presented test result.			

5 MEASUREMENTS, EXAMINATION AND DERIVED RESULTS

5.1 Antenna Requirement

Requirement(s): 47 CFR §15.203

An intentional radiator shall be designed to ensure that no antenna other than that furnished by the responsible party shall be used with the device.

Antenna requirement must meet at least one of the following:

- a) Antenna must be permanently attached to the device.
 - b) Antenna must use a unique type of connector to attach to the device.
 - c) Device must be professionally installed. Installer shall be responsible for ensuring that the correct antenna is employed with the device.
- 1) The EUT antenna is attached permanently to the device which meets the requirement.

5.2 Conducted Emissions Voltage

Requirement:

Frequency of emission (MHz)	Conducted limit (dB μ V)	
	Quasi-peak	Average
0.15–0.5	66 to 56*	56 to 46*
0.5–5	56	46
5–30	60	50

*Decreases with the logarithm of the frequency.

Procedures:

1. All possible modes of operation were investigated. Only the 6 worst case emissions measured, using the correct CISPR and Average detectors, are reported. All other emissions were relatively insignificant.
2. A "-ve" margin indicates a PASS as it refers to the margin present below the limit line at the particular frequency.
3. Conducted Emissions Measurement Uncertainty
 All test measurements carried out are traceable to national standards. The uncertainty of the measurement at a confidence level of approximately 95% (in the case where distributions are normal), with a coverage factor of 2, in the range 150kHz – 30MHz (Average & Quasi-peak) is ± 3.5 dB.
4. Environmental Conditions

Temperature	25°C
Relative Humidity	50%
Atmospheric Pressure	1019mbar

Test Date : November 26 to 28, 2008

Tested By : Dan Corona

Test Result: Pass

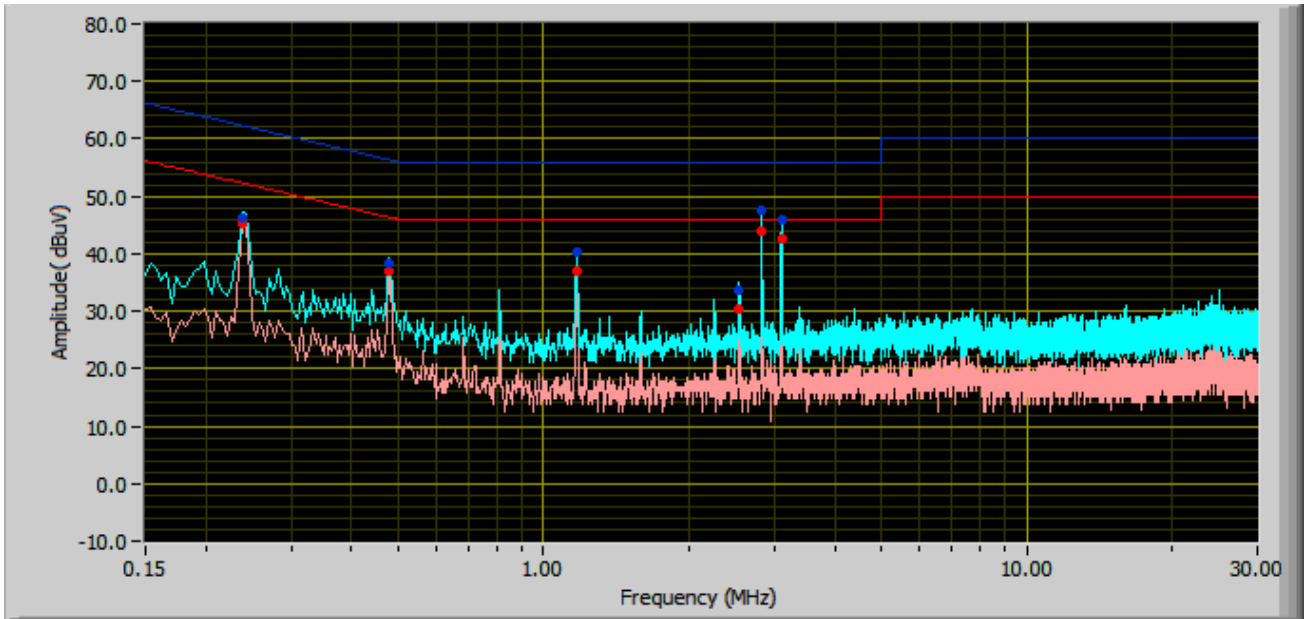

Quasi-Peak Limit

Average Limit

Phase Line Plot at 120Vac, 60Hz

Frequency (MHz)	QP Value (dB μ V)	Class B Limit (dB)	Pass / Fail	Margin (dB)	Avg Value (dB μ V)	Class B Limit (dB)	Pass / Fail	Margin (dB)	Line
2.83	47.42	56.00	PASS	-8.58	43.97	46.00	PASS	-2.03	Phase
3.11	45.77	56.00	PASS	-10.23	42.46	46.00	PASS	-3.54	Phase
0.24	46.32	62.28	PASS	-15.96	45.29	52.28	PASS	-6.99	Phase
1.17	40.24	56.00	PASS	-15.76	36.98	46.00	PASS	-9.02	Phase
0.48	38.28	56.38	PASS	-18.10	36.89	46.38	PASS	-9.49	Phase
2.54	33.55	56.00	PASS	-22.45	30.34	46.00	PASS	-15.66	Phase

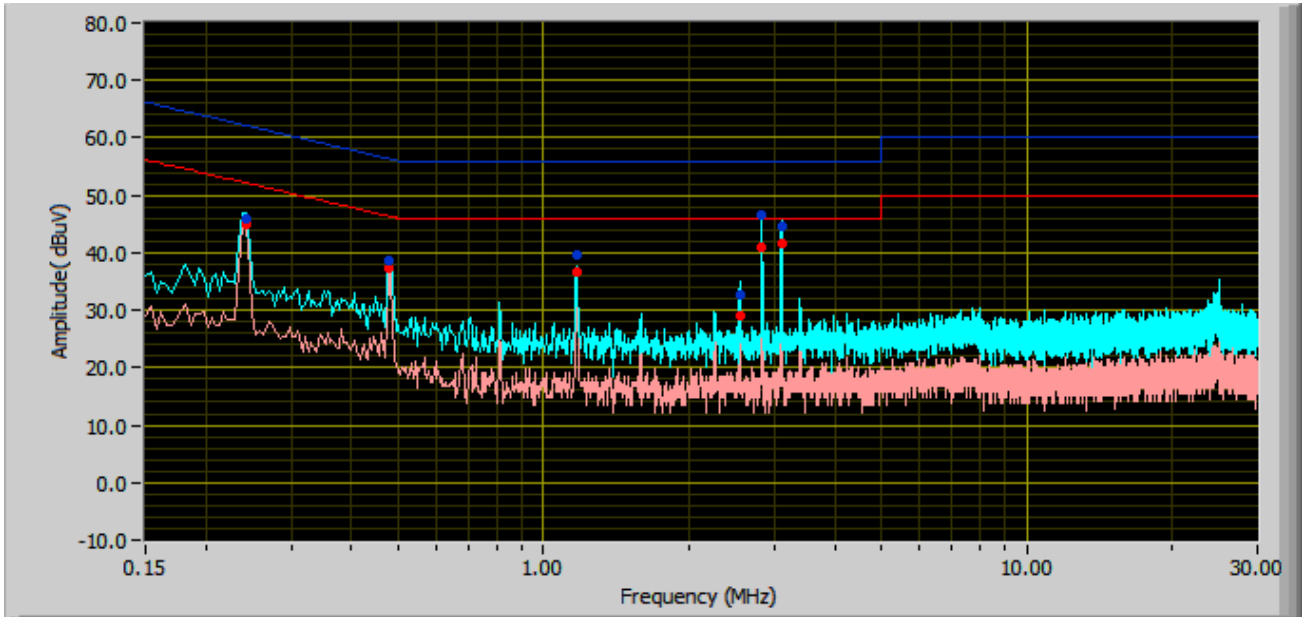

Quasi-Peak Limit

Average Limit

Neutral Line Plot at 120Vac, 60Hz

Frequency (MHz)	QP Value (dB μ V)	Class B Limit (dB)	Pass / Fail	Margin (dB)	Avg Value (dB μ V)	Class B Limit (dB)	Pass / Fail	Margin (dB)	Line
3.11	44.76	56.00	PASS	-11.24	41.65	46.00	PASS	-4.35	Neutral
2.83	46.50	56.00	PASS	-9.50	40.94	46.00	PASS	-5.06	Neutral
0.24	45.89	62.14	PASS	-16.25	44.80	52.14	PASS	-7.34	Neutral
0.48	38.51	56.38	PASS	-17.86	37.17	46.38	PASS	-9.20	Neutral
1.17	39.68	56.00	PASS	-16.32	36.52	46.00	PASS	-9.48	Neutral
2.55	32.84	56.00	PASS	-23.16	28.97	46.00	PASS	-17.03	Neutral

5.3 Radiated Spurious Emission (Out-of-Band) Test Results

Requirement(s): 47 CFR §15.209; 47 CFR §15.245 (b) (1)

Procedures: Radiated emissions were measured according to ANSI C63.4. The EUT was set to transmit at the highest output power. The EUT was set 3 meter away from the measuring antenna. The Log Periodic Antenna was positioned 1 meter above the ground from the centre of the loop. The measuring bandwidth was set to 100 kHz. (Note: During testing the receive antenna was raise from 1~4 meters to maximize the emission from the EUT.)

1. All possible modes of operation were investigated. Only the 6 worst case emissions measured, using the correct CISPR detectors, are reported. All other emissions were relatively insignificant.
2. A "-ve" margin indicates a PASS as it refers to the margin present below the limit line at the particular frequency.
3. Radiated Emissions Measurement Uncertainty
 All test measurements carried out are traceable to national standards. The uncertainty of the measurement at a confidence level of approximately 95% (in the case where distributions are normal), with a coverage factor of 2, in the range 30MHz – 1GHz (QP only @ 3m & 10m) is +5.6dB/-4.5dB (for EUTs < 0.5m X 0.5m X 0.5m).
4. Environmental Conditions

Temperature	25°C
Relative Humidity	50%
Atmospheric Pressure	1019mbar

Test Date : November 26 to 28, 2008
 Tested By : Dan Corona

Test Result: Pass

Test result complying for FCC 15.245 (b) (3) & 15.209

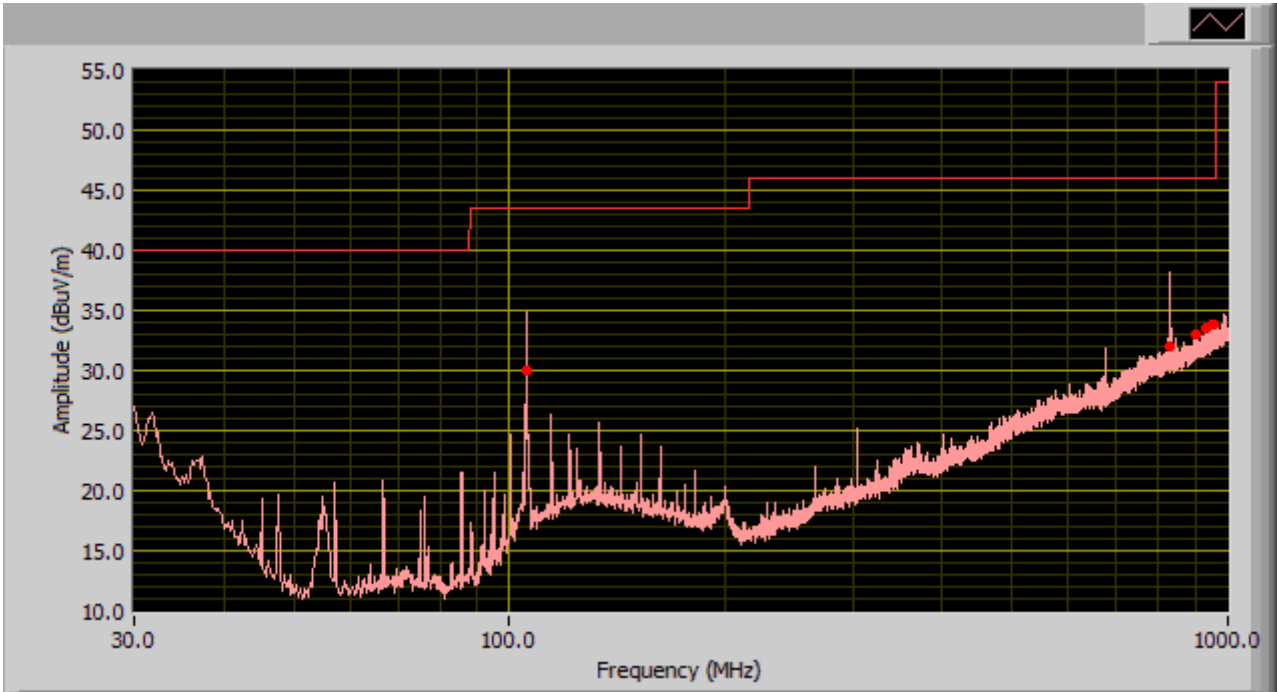

30MHz ~1000MHz

Frequency (MHz)	Quasi-Peak (dBμV/m) @ 3m	Antenna height (cm)	Turntable position (deg)	Polarity	Limit (dBμV/m)	Margin (dB)
827.77	31.92	366.00	46.00	H	46.00	-14.08
105.71	30.05	238.00	130.00	V	43.50	-13.45
955.12	33.86	226.00	42.00	H	46.00	-12.14
947.29	33.82	258.00	111.00	H	46.00	-12.18
932.10	33.43	304.00	1.00	H	46.00	-12.57
901.14	32.97	379.00	359.00	H	46.00	-13.03

5.4 Radiated Fundamental & Spurious Emissions

Requirement(s): 47 CFR §15.209; 47 CFR §15.245 (b) (1)

Procedures: Radiated emissions were measured according to ANSI C63.4. The EUT was set to transmit at the highest output power. The EUT was set 3 meter away from the measuring antenna. The Horn Antenna (1-18GHz) was positioned 1 meter above the ground from the centre of the loop to measure the fundamental and 18-40GHz for Harmonics spurious emission (Note: During testing the receive antenna was raise from 1~4 meters to maximize the emission from the EUT.)

The limit is converted from microvolts/meter to decibel microvolts/meter.

Sample Calculation: Corrected Amplitude = Raw Amplitude (dBµV/m) + ACF (dB) + Cable Loss (dB) – Pre-Amp.

5.4.1 Test Result: Pass

Radiated Emissions Field Strength of Fundamental

Frequency (GHz)	Azimuth (Degrees)	Antenna Polarity (H/V)	Height (m)	Raw Amp. @ 3m (dBµV)	Pre Amp. (dB)	Ant .Corr. Factor (dB)	Cable Loss (dB)	EUT Final Field Strength (dBµV/m)	Limit @ 3m (dBµV/m)	Delta (dBµV/m)	Detector (pk/avg)
24.120	89.00	V	1.70	55.85	27.20	33.10	39.20	100.95	148.0	-47.05	Peak
24.120	0.00	H	1.10	72.82	27.20	33.10	39.20	117.92	148.0	-30.08	Peak
24.120	89.00	V	1.70	54.36	27.20	33.10	39.20	99.46	128.0	-28.54	Ave
24.120	0.00	H	1.10	72.41	27.20	33.10	39.20	117.51	128.0	-10.49	Ave

Radiated Emissions Field Strength of Harmonics

Frequency (GHz)	Azimuth (Degrees)	Antenna Polarity (H/V)	Height (m)	Raw Amp. @ 3m (dBµV)	Pre Amp. (dB)	Ant .Corr. Factor (dB)	Cable Loss (dB)	EUT Final Field Strength (dBµV/m)	Limit @ 3m (dBµV/m)	Delta (dBµV/m)	Detector (pk/avg)
48.250	140	V	1.2	32.03	30.45	38.70	24.71	64.99	108.00	-43.01	Peak/ Noise Floor
48.250	189	H	1.5	31.08	30.45	38.70	24.71	64.04	108.00	-43.96	Peak/ Noise Floor
48.250	140	V	1.2	30.18	30.45	38.70	24.71	63.14	88.00	-24.86	Ave/ Noise Floor
48.250	189	H	1.5	30.15	30.45	38.70	24.71	63.11	88.00	-24.89	Ave/ Noise Floor

Note: Emission was scanned up to 100GHz; no emissions were detected above the noise floor which was at least 20 dB below the specification limit.

Annex A. TEST INSTRUMENT & METHOD

Annex A.i. TEST INSTRUMENTATION & GENERAL PROCEDURES

Instrument	Model	Serial #	Calibration Due
AC Conducted Emissions			
R&S EMI Test Receiver	ESIB40	100179	04/25/2009
R&S LISN	ESH2-Z5	861741/013	04/24/2009
CHASE LISN	MN2050B	1018	04/24/2009
Radiated Emissions			
R&S EMI Test Receiver	ESIB40	100179	04/25/2009
Com Power Corp Horn Antenna (18GHz to 40GHz)	AH-840	101013	03/19/2010
EMCO Horn Antenna (1-18GHz)	3115	10SL0059	01/04/2009
Sunol Sciences, Inc. antenna (30MHz~2GHz)	JB1	A030702	10/04/2009
Wiltron Signal Generator (10MHz to 40GHz)	68169B	973407	04/25/2009
Com Power Preamplifier (18GHz to 40GHz)	PA-840	181250	05/21/2009
HP Preamplifier (1-26.5GHz)	8449B	3008A00715	04/24/2009
HP Preamplifier (0.1-1300MHz)	8447F	1937A01160	04/24/2009
MILITECH, External Mixer (Above 40GHz)	MHB-06-RD3AO	9259	N/A
MILITGECH, Horn Antenna (above 40GHz)	WT-KaD	WT28-6	N/A

Annex A.ii. CONDUCTED EMISSIONS TEST DESCRIPTION

Test Set-up

1. The EUT and supporting equipment were set up in accordance with the requirements of the standard on top of a 1.5m x 1m x 0.8m high, non-metallic table, as shown in [Annex B](#).
2. The power supply for the EUT was fed through a 50Ω/50μH EUT LISN, connected to filtered mains.
3. The RF OUT of the EUT LISN was connected to the EMI test receiver via a low-loss coaxial cable.
4. All other supporting equipments were powered separately from another main supply.

Test Method

1. The EUT was switched on and allowed to warm up to its normal operating condition.
2. A scan was made on the NEUTRAL line (for AC mains) or Earth line (for DC power) over the required frequency range using an EMI test receiver.
3. High peaks, relative to the limit line, were then selected.
4. The EMI test receiver was then tuned to the selected frequencies and the necessary measurements made with a receiver bandwidth setting of 10 KHz. For FCC tests, only Quasi-peak measurements were made; while for CISPR/EN tests, both Quasi-peak and Average measurements were made.
5. Steps 2 to 4 were then repeated for the LIVE line (for AC mains) or DC line (for DC power).

Sample Calculation Example

At 20 MHz

limit = 250 μV = 47.96 dBμV

Transducer factor of LISN, pulse limiter & cable loss at 20 MHz = 11.20 dB

Q-P reading obtained directly from EMI Receiver = 40.00 dBμV

(Calibrated for system losses)

Therefore, Q-P margin = 47.96 – 40.00 = 7.96

i.e. **7.96 dB below limit**

Annex A. iii RADIATED EMISSIONS TEST DESCRIPTION

EUT Characterisation

EUT characterisation, over the frequency range from 30MHz to 10th Harmonic , was done in order to minimise radiated emissions testing time while still maintaining high confidence in the test results.

The EUT was placed in the chamber, at a height of about 0.8m on a turntable. Its radiated emissions frequency profile was observed, using a spectrum analyzer /receiver with the appropriate broadband antenna placed 3m away from the EUT. Radiated emissions from the EUT were maximised by rotating the turntable manually, changing the antenna polarisation and manipulating the EUT cables while observing the frequency profile on the spectrum analyzer / receiver. Frequency points at which maximum emissions occurred, clock frequencies and operating frequencies were then noted for the formal radiated emissions test at the Open Area Test Site (OATS).

Test Set-up

1. The EUT and supporting equipment were set up in accordance with the requirements of the standard on top of a 1.5m X 1.0m X 0.8m high, non-metallic table.
2. The filtered power supply for the EUT and supporting equipment were tapped from the appropriate power sockets located on the turntable.
3. The relevant broadband antenna was set at the required test distance away from the EUT and supporting equipment boundary.

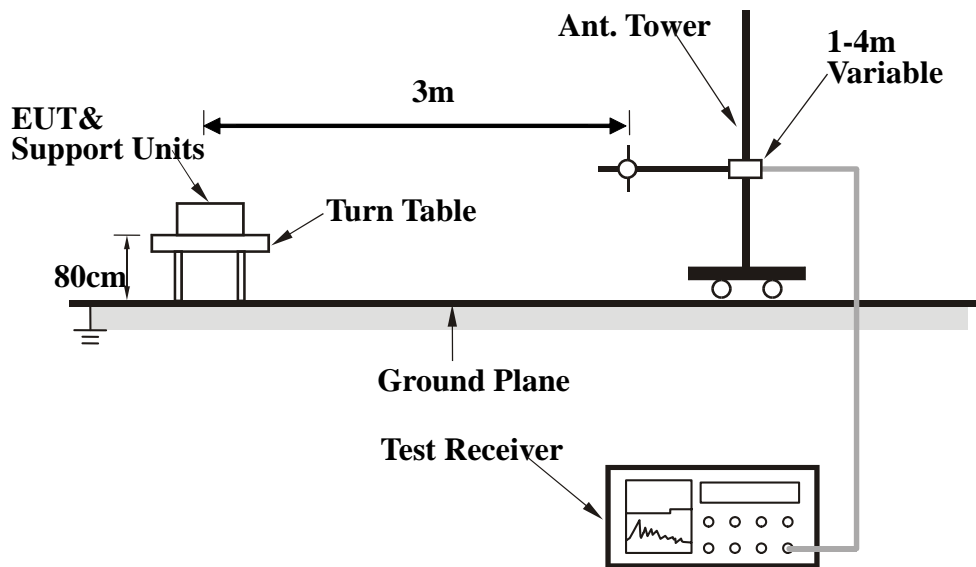

Test Method

The following procedure was performed to determine the maximum emission axis of EUT:

1. With the receiving antenna is H polarization, rotate the EUT in turns with three orthogonal axes to determine the axis of maximum emission.
2. With the receiving antenna is V polarization, rotate the EUT in turns with three orthogonal axes to determine the axis of maximum emission.
3. Compare the results derived from above two steps. So, the axis of maximum emission from EUT was determined and the configuration was used to perform the final measurement.

Final Radiated Emission Measurement

1. Setup the configuration according to figure 1. Turn on EUT and make sure that it is in normal function.
2. For emission frequencies measured below 1 GHz, a pre-scan is performed in a shielded chamber to determine the accurate frequencies of higher emissions will be checked on a open test site. As the same purpose, for emission frequencies measured above 1 GHz, a pre-scan also be performed with a 1 meter measuring distance before final test.
3. For emission frequencies measured below and above 1 GHz, set the spectrum analyzer on a 100 kHz and 1 MHz resolution bandwidth respectively for each frequency measured in step 2.
4. The search antenna is to be raised and lowered over a range from 1 to 4 meters in horizontally polarized orientation. Position the height when the highest value is indicated on spectrum analyzer, then change the orientation of EUT on test table over a range from 0° to 360° with a speed as slow as possible, and keep the azimuth that highest emission is indicated on the spectrum analyzer. Vary the antenna position again and record the highest value as a final reading.
5. Repeat step 4 until all frequencies need to be measured were complete.
6. Repeat step 5 with search antenna in vertical polarized orientations.

During the radiated emission test, the Spectrum Analyzer was set with the following configurations:

Frequency Band (MHz)	Function	Resolution bandwidth	Video Bandwidth
30 to 1000	Peak	100 kHz	100 kHz
Above 1000	Peak	1 MHz	1 MHz
	Average	1 MHz	10 Hz

Sample Calculation Example

The field strength is calculated by adding the Antenna Factor and Cable Factor, and subtracting the Amplifier Gain (if any) from the measured reading. For the limit is employed average value, therefore the peak value can be transferred to average value by subtracting the duty factor. The basic equation with a sample calculation is as follows:

$$\text{Peak} = \text{Reading} + \text{Corrected Factor}$$

where

$$\text{Corr. Factor} = \text{Antenna Factor} + \text{Cable Factor} - \text{Amplifier Gain (if any)}$$

And the average value is

$$\text{Average} = \text{Peak Value} + \text{Duty Factor or}$$

$$\text{Set RBW} = 1\text{MHz, VBW} = 10\text{Hz.}$$

Note :

If the measured frequencies are fall in the restricted frequency band, the limit employed must be quasi peak value when frequencies are below or equal to 1 GHz. And the measuring instrument is set to quasi peak detector function.

Annex B EUT AND TEST SETUP PHOTOGRAPHS

Please see the attachment

Annex C. TEST SETUP AND SUPPORTING EQUIPMENT

EUT TEST CONDITIONS

Annex C. i. SUPPORTING EQUIPMENT DESCRIPTION

The following is a description of supporting equipment and details of cables used with the EUT.

Equipment Description (Including Brand Name)	Model & Serial Number	Cable Description (List Length, Type & Purpose)
Topward Electric Instrument Co., Ltd. Linear AC/DC Power Supply	Model: TPS-2000 SN: 920035	N/A

NOTE: No special supporting equipment are used or needed during testing to achieve compliance.

Block Configuration Diagram for Radiated Emission

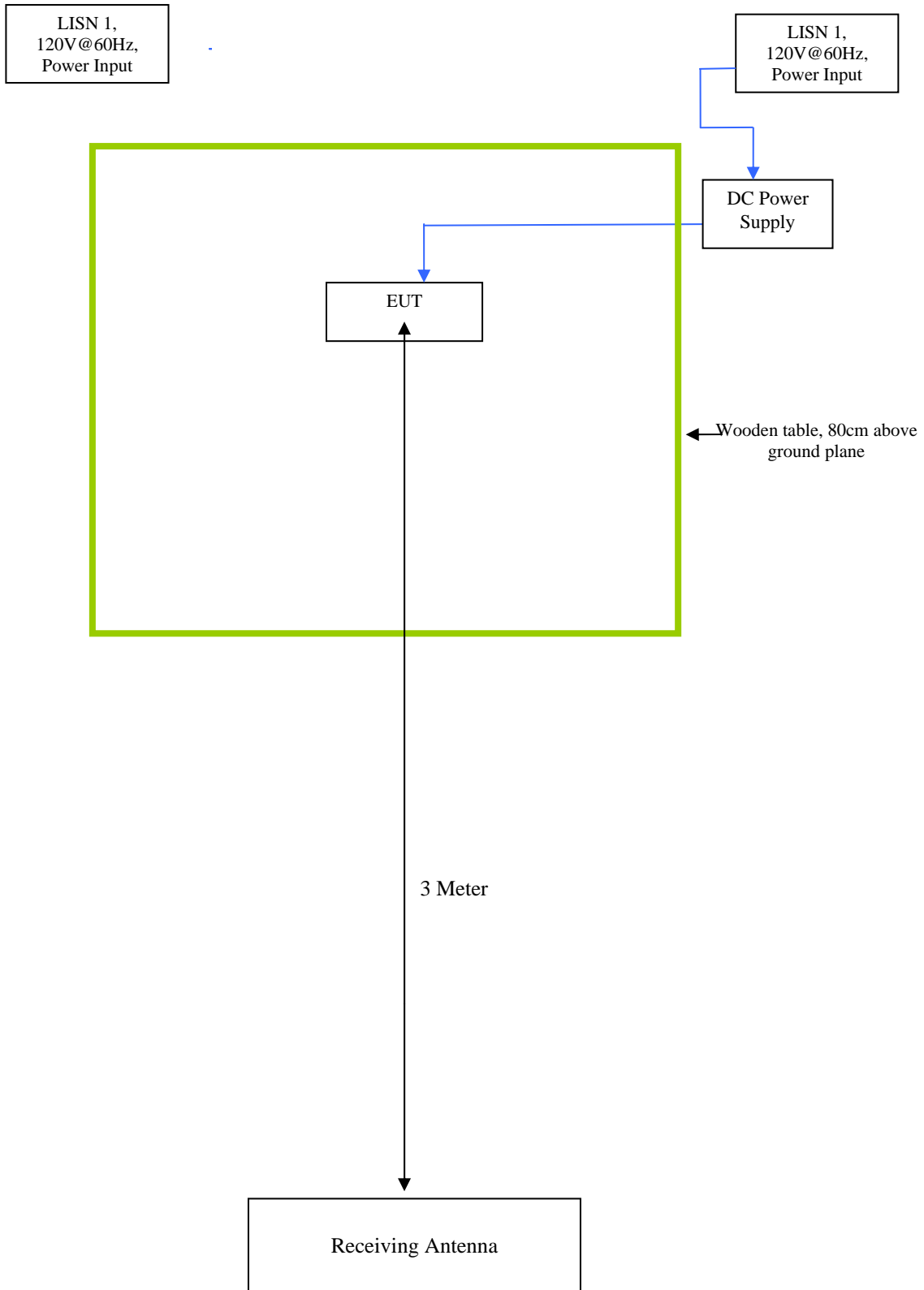

Block Configuration Diagram for Conducted Emission

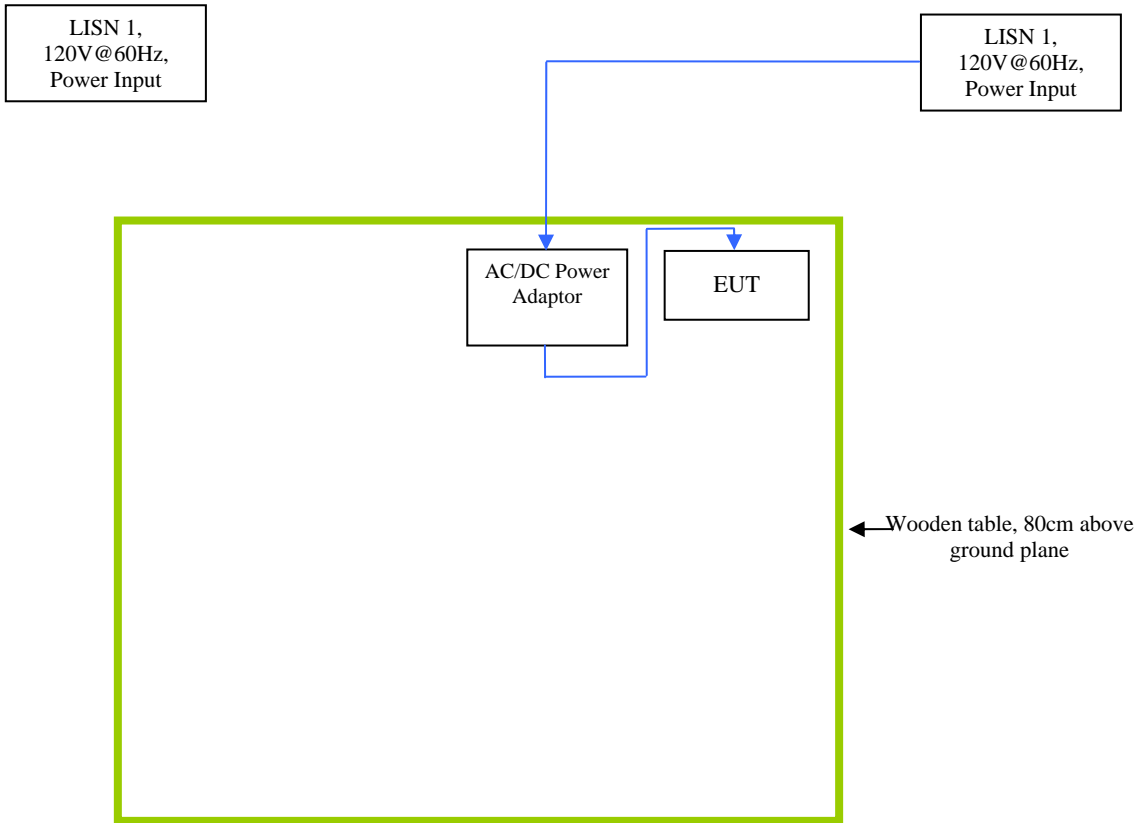

Annex C.ii. EUT OPERATING CONDITIONS

The following is the description of how the EUT is exercised during testing.

Test	Description Of Operation
Emissions Testing	The EUT was controlled by itself.
Others Testing	The EUT was controlled by itself.

Annex D USER MANUAL, BLOCK & CIRCUIT DIAGRAM

Please see attachment