

EMI -- TEST REPORT

Test Report No. : T30312-02-01HS	November 7, 2007
	Date of issue

Type / Model Name : 1270 1335 LP Steuerung WLAN Konverter

Product Description : WLAN Ethernet Module

Applicant : SEW-EURODRIVE GmbH & Co KG

Address : Ernst-Blickle-Straße 42

DE-76646 Bruchsal

Manufacturer : SEW-EURODRIVE GmbH & Co KG

Address : Ernst-Blickle-Straße 42

DE-76646 Bruchsal

Licence holder : SEW-EURODRIVE GmbH & Co KG

Address : Ernst-Blickle-Straße 42

DE-76646 Bruchsal

Test Result according to the standards listed in clause 1 test standards:	Positive
--	-----------------



DAT-P-207/05-00

The test report merely corresponds to the test sample. It is not permitted to copy extracts of these test results without the written permission of the test laboratory.

Contents

1	<u>TEST STANDARDS</u>	3
2	<u>SUMMARY</u>	4
3	<u>EQUIPMENT UNDER TEST</u>	5
3.1	PHOTO DOCUMENTATION OF THE EUT	5
3.2	POWER SUPPLY SYSTEM UTILISED	7
3.3	SHORT DESCRIPTION OF THE EQUIPMENT UNDER TEST (EUT)	7
4	<u>TEST ENVIRONMENT</u>	9
4.1	ADDRESS OF THE TEST LABORATORY	9
4.2	ENVIRONMENTAL CONDITIONS	9
4.3	STATEMENT OF THE MEASUREMENT UNCERTAINTY	9
4.4	MEASUREMENT PROTOCOL FOR FCC, VCCI AND AUSTEL	9
4.5	DISCOVERY OF WORST CASE MEASUREMENT CONDITIONS	10
5	<u>TEST CONDITIONS AND RESULTS</u>	11
5.1	CONDUCTED EMISSIONS	11
5.2	MAXIMUM PEAK CONDUCTED OUTPUT POWER	12
5.3	RADIATED EMISSIONS 9 KHZ – 40 GHZ	14
5.4	6 DB BANDWIDTH	22
5.5	BAND EDGE TEST	27
5.6	PEAK POWER DENSITY	31
5.7	CORRECTION FOR PULSE OPERATION (DUTY CYCLE)	33
5.8	ANTENNA APPLICATION	33
5.9	RECEIVER CONDUCTED DISTURBANCES 0.15 - 30 MHZ	37
5.10	RECEIVER RADIATED EMISSIONS 9 KHZ - 40 GHZ	38
5.11	MAXIMUM PERMISSIBLE EXPOSURE (MPE)	43
6	<u>USED TEST EQUIPMENT AND ACCESSORIES</u>	45

1 TEST STANDARDS

The tests were performed according to following standards:

FCC Rules and Regulations Part 15 Subpart C - Intentional Radiators (May 04, 2007)

Part 15, Subpart C, Section 15.31	Measuring standards
Part 15, Subpart C, Section 15.33	Frequency range of radiated measurements
Part 15, Subpart C, Section 15.35(c)	Correction for pulse operation (Duty Cycle)
Part 15, Subpart C, Section 15.203	Antenna requirement
Part 15, Subpart C, Section 15.204	External radio frequency power amplifiers and antenna modifications
Part 15, Subpart C, Section 15.205	Restricted bands of operation
Part 15, Subpart C, Section 15.212	Modular transmitter
Part 15, Subpart C, Section 15.207(a)	AC Line conducted emissions
Part 15, Subpart C, Section 15.209(a)	Radiated emissions, general requirements
Part 15, Subpart C, Section 15.247(d)	Radiated emissions, outside the used frequency band
Part 15, Subpart C, Section 15.247(a)(2)	Bandwidth requirement
Part 15, Subpart C, Section 15.247(b)(3)	Maximum Peak conducted output Power
Part 15, Subpart C, Section 15.247(i)	Exposure of radio frequency energy levels

FCC Rules and Regulations Part 15 Subpart B - Unintentional Radiators (May 04, 2007)

Part 15, Subpart B, Section 15.107(a)	AC Line conducted emissions
Part 15, Subpart B, Section 15.109(a)	Radiated emissions, general requirements

2 SUMMARY

GENERAL REMARKS:

The Eut will be approved as modular transmitter according the §15.212 for professional installations. Because of the Eut beeing a modul the limited modular approvals under paragraph 15.212(b) applies.

Antenna Configurations:

Following antennas will be used with the EuT:

Type	Frequency range	Gain (typical)
IW-145	2400-2483,5 MHz	4 dBi
SOA 2400/360/4/20/V	2400-2500 MHz	4 dBi
12705195 RSF12-50 JFN S Radiating cable	2400 MHz - 2600 MHz	0 dBi
13000810 Dual Band Antenna	2400-2483,5	Max. 5,9 dBi

In final WLAN Module configuration, a special firmware is used to operate the EuT only in the approved channel 1 - 11:

1270 5551 WLAN-Client-World prg
1270 1335 LP Steuerung WLAN Konverter
1270 5616 FW WLAN Client World

1270 5586 WLAN-AP-World prg
1270 1335 LP Steuerung WLAN Konverter
1270 5632 FW WLAN AP World

FINAL ASSESSMENT:

The equipment under test **fulfills** the EMI requirements cited in clause 1 test standards.

Date of receipt of test sample : acc. to storage records

Testing commenced on : October 25, 2005

Testing concluded on : November 06, 2007

Checked by:

Tested by:

Klaus Gegenfurtner
Dipl.-Ing.(FH)
Manager: Radio Group

Hermann Smetana
Dipl.-Ing.(FH)
Radio Expert

3 EQUIPMENT UNDER TEST

3.1 Photo documentation of the EuT

Top view of EuT
1270 1335 LP WLAN Converter Control Unit

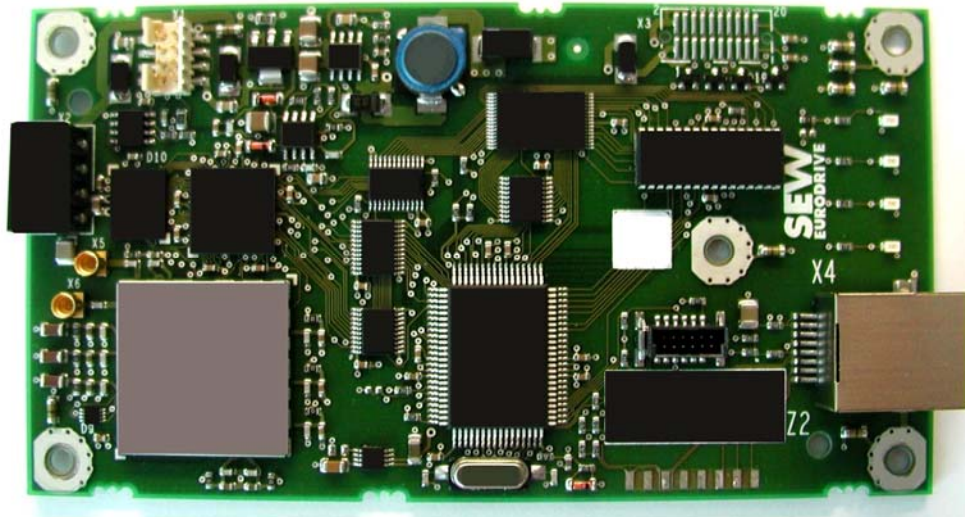

Top view of EuT part without RF-shielding

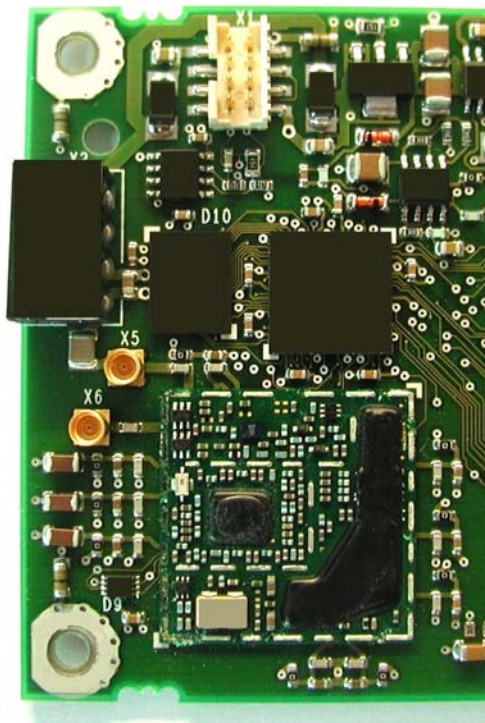

Top view of EuT part
1270 1335 LP WLAN Converter Control Unit

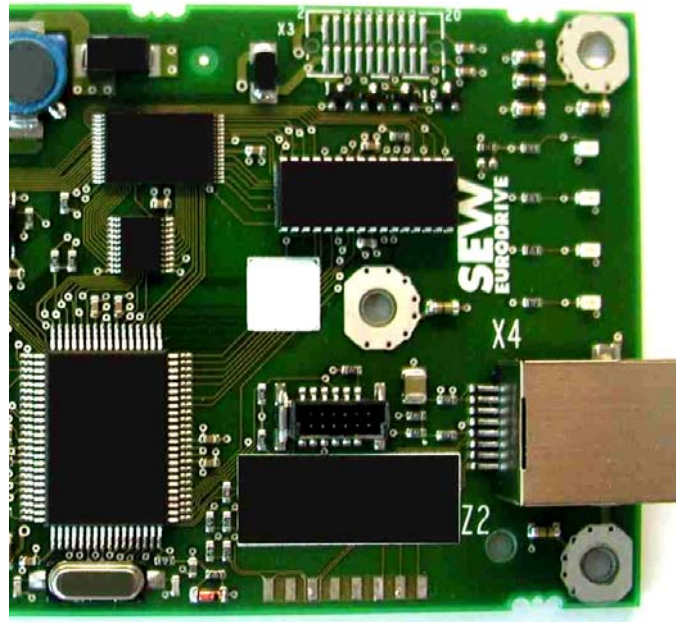

Rear view of EuT
1270 1335 LP WLAN Converter Control Unit

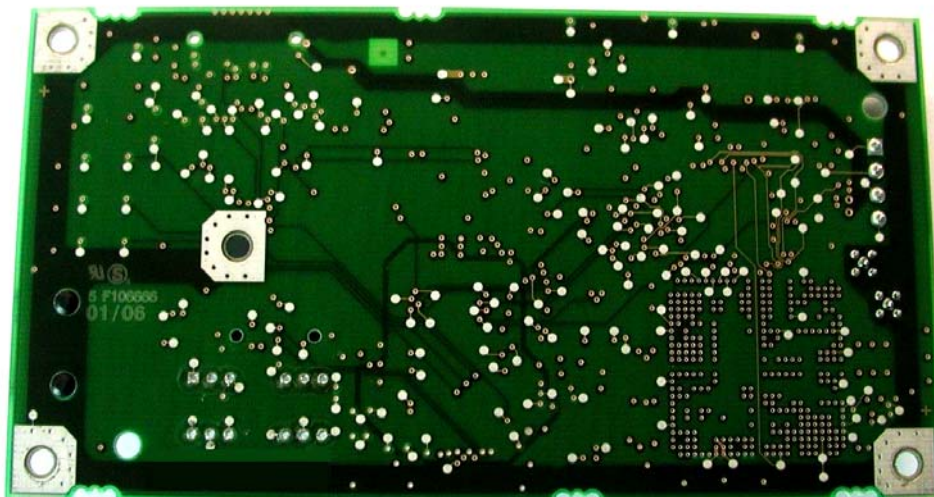

3.2 Power supply system utilised

Power supply voltage : 24 V / DC

3.3 Short description of the Equipment under Test (EuT)

The „1270 1335 LP Steuerung WLAN Konverter“ Hardware can be used modular as Access Point or as a Station (host) for MOVIPRO®. It is professional used in industrial environment.

Plant concept with a MOVIPRO® drive control system:

MOVIPRO® is used in:

- Linear-motion platforms in automobile production
- Overhead trolley drives in the automotive industry
- Lane vehicles for storage and retrieval units
- Conveyor trolleys
- Transportation systems

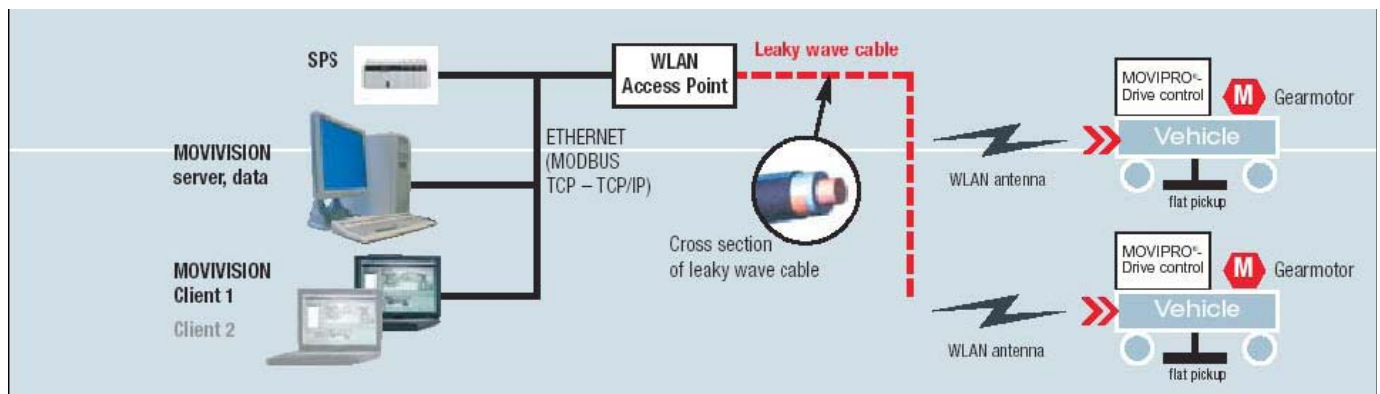

The mobile devices (vehicles) are supplied from the contactless energy transfer system MOVITRANS®. The contactless data transmission is done by the „1270 1335 LP Steuerung WLAN Konverter“ Hardware.

Functional principle of MOVIPRO®:

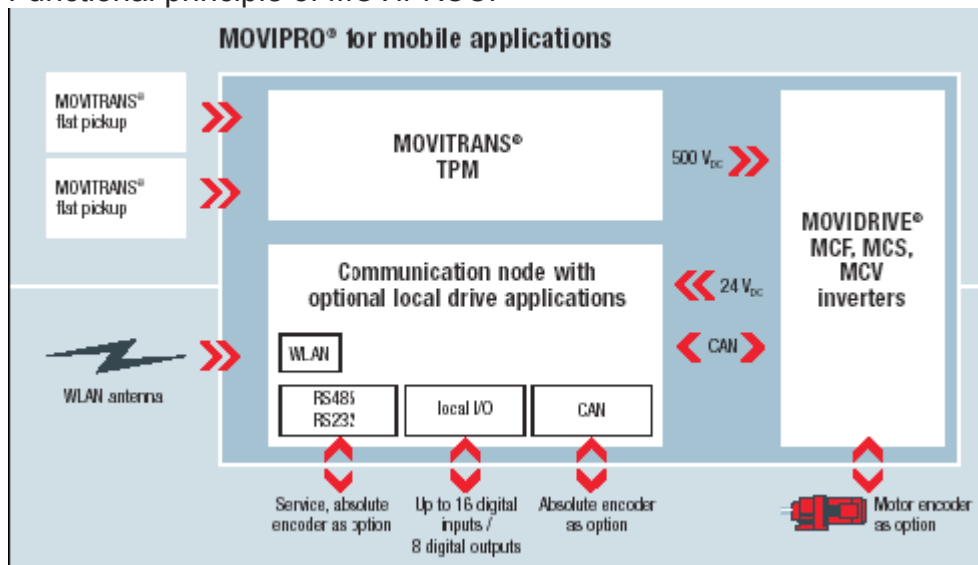

Number of tested samples: 1
Serial number: 12701335

EuT operation mode:

The equipment under test was operated during the measurement under the following conditions:

- TX-mode with modulation _____

- TX-mode without modulation _____

- RX-mode _____

EuT configuration:

(The CDF filled by the applicant can be viewed at the test laboratory.)

The following peripheral devices and interface cables were connected during the measurements:

- _____ Model : _____

- _____ Model : _____

- _____ Model : _____

- _____ Model : _____

- _____ Model : _____

- _____ Model : _____

4 TEST ENVIRONMENT

4.1 Address of the test laboratory

**mikes-testingpartners gmbh
Ohmstrasse 2-4
94342 Strasskirchen
Germany**

4.2 Environmental conditions

During the measurement the environmental conditions were within the listed ranges:

Temperature: 15-35 ° C

Humidity: 30-60 %

Atmospheric pressure: 86-106 kPa

4.3 Statement of the measurement uncertainty

The data and results referenced in this document are true and accurate. The reader is cautioned that there may be errors within the calibration limits of the equipment and facilities. The measurement uncertainty was calculated for all measurements listed in this test report acc. to CISPR 16-4-2 /11.2003 „Uncertainties, statistics and limit modelling – Uncertainty in EMC measurements“ and is documented in the quality system acc. to DIN EN ISO/IEC 17025. Furthermore, component and process variability of devices similar to that tested may result in additional deviation. The manufacturer has the sole responsibility of continued compliance of the device.

4.4 Measurement Protocol for FCC, VCCI and AUSTEL

4.4.1 GENERAL INFORMATION

4.4.1.1 Test Methodology

Conducted and radiated disturbance testing is performed according to the procedures in International Special Committee on Radio Interference (CISPR) Publication 22, European Standard EN 55022 as shown under section 1 of this report.

In compliance with 47 CFR Part 15 Subpart A Section 15.38 testing for FCC compliance may be done following the ANSI C63.4-2003 procedures and using the CISPR 22 Limits.

4.4.1.2 Justification

The Equipment Under Test (EUT) is configured in a typical user arrangement in accordance with the manufacturer's instructions. A cable is connected to each available port and either terminated with a peripheral using the appropriate impedance characteristic or left unterminated. Where appropriate, cables are manually manipulated with respect to each other thus obtaining maximum disturbances from the unit.

4.4.2 DETAILS OF TEST PROCEDURES

4.4.2.1 General Standard Information

The test methods used comply with CISPR Publication 22, EN 55022 - "Information technology equipment - Radio disturbance characteristics - Limits and methods of measurement" and with ANSI C63.4-2003 - "Methods of Measurement of Radio-Noise Emissions from Low-Voltage Electrical and Electronic Equipment in the Range of 9 kHz to 40 GHz."

4.5 Discovery of worst case measurement conditions

Antenna Configurations:

Following antennas are recommended for use with the EuT:

Type	Frequency range	Gain (typical)
IW-145	2400 – 2483.5 MHz	4 dBi
SOA 2400/360/4/20/V	2400 - 2500 MHz	4 dBi
12705195 RSF12-50 JFN S Radiating cable	2400 - 2600 MHz	0 dBi
13000810 Dual Band Antenna	2400 – 2483.5	max. 5.9 dBi

To find out the worst case antenna configurations for the complete measurement we have performed the test "Carrier power" and "Spurious emissions" on all antenna configurations. The radiating cable (leaky cable) was specially tested according the PN 347215.

As result all tests were performed with antenna model "13000810 Dual Band Antenna" as worst case.

5 TEST CONDITIONS AND RESULTS

5.1 Conducted emissions

For test instruments and accessories used see section 6 Part A 4.

5.1.1 Description of the test location

Test location: NONE

Remarks: The measurement is not applicable because the EuT is DC powered.

The batteries for power supply of the Eut may charged only if the EuT is switched off.

5.2 Maximum Peak Conducted Output Power

For test instruments and accessories used see section 6 Part CPC 3.

5.2.1 Description of the test location

Test location: Area4

5.2.2 Photo documentation of the test set-up



5.2.3 Description of Measurement

Conducted maximum peak output power:

A spectrum analyzer / EMI test receiver is connected to the output of the transmitter via a suitable attenuator while EuT was operating in transmit mode using the assigned frequency.

Analyzer Settings:

- Detector: Max hold
- RBW: greater than 20 dB Bandwidth
- VBW: \geq RBW
- Sweep Time: Coupled

5.2.4 Test result

Channel	Frequency [MHz]	Peak Power Output (dBm)	Correct. [dB]	Corr. Peak Power Output (dBm)	Peak Power Limit (dBm)	Delta [dB]
1	2412	11,72	0,0	11,72	30,0	-18,28
6	2437	11,51	0,0	11,51	30,0	-18,49
11	2462	11,92	0,0	11,92	30,0	-18,08

Peak Power Limit according to FCC Subpart 15.247(b)(3)

Frequency (MHz)	Peak Power Limit	
	(dBm)	(Watt)
902-928	30	1,0
2400-2483.5	30	1,0
5725-5850	30	1,0

The requirements are **FULFILLED**.

Remarks: This test has been performed conducted at antenna jack on PCB.

5.3 Radiated emissions 9 kHz – 40 GHz

For test instruments and accessories used see section 6 Part SER1, SER 2 and SER 3.

5.3.1 Description of the test location

Test location: OATS1
Anechoic Chamber A2

Test distance: 3 metres

5.3.2 Photo documentation of the test set-up



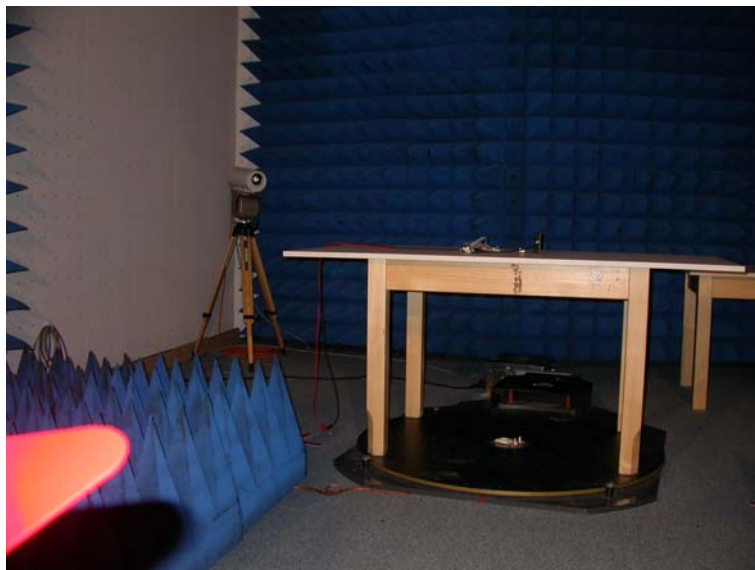
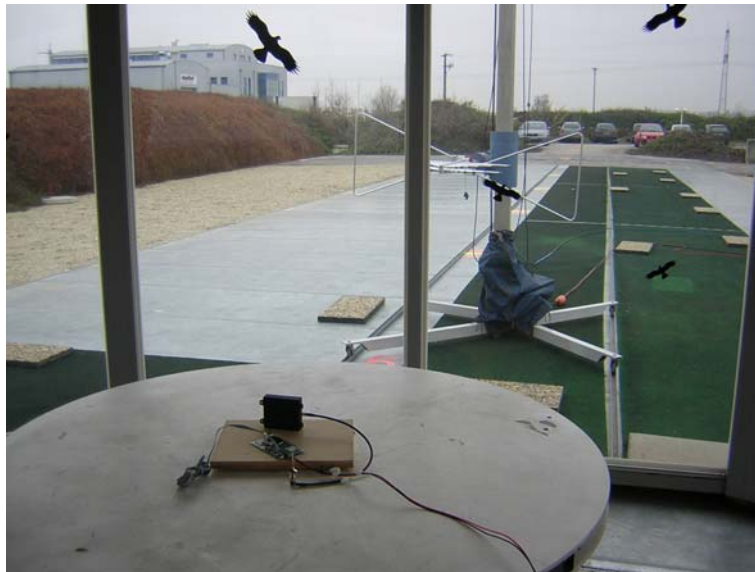

5.3.3 Description of Measurement

The spurious emissions from the EuT will be measured on an open area test site in the frequency range of 9 kHz to 30 MHz using a tuned receiver and a shielded loop antenna. The antenna was positioned 3, 10 or 30 meters horizontally from the EuT. Measurements have been made in all three orthogonal axes and the shielded loop antenna was rotated to locate the maximum of the emissions. In the case where larger measuring distances are required the results will be extrapolated based on the values measured on the closer distances according to Section 15.31 (f) (2) [2]. The final measurement will be performed with an EMI Receiver set to Quasi Peak detector except for the frequency bands 9 kHz to 90 kHz and 110 to 490 kHz where an average detector will be used according to Section 15.209 (d) [2].

The final level, expressed in dB μ V/m, is arrived at by taking the reading from the EMI receiver (Level dB μ V) and adding the antenna correction factor and cable loss factor (Factor dB) to it. This result then has to be compared with the relevant FCC limit.

The resolution bandwidth during the measurement is as follows:

9 kHz – 150 kHz: ResBW: 200 Hz

150 kHz – 30 MHz: ResBW: 9 kHz

Radiated spurious emissions from the EuT are measured in the frequency range of 30 MHz to 1000 MHz using a tuned receiver and appropriate broadband linearly polarized antennas. Measurements between 30 MHz and 1000 MHz are made with 120 kHz/6 dB bandwidth and quasi-peak detection. Table top equipment is placed on a 1.0 X 1.5 meter non-conducting table 80 centimetres above the ground plane. Floor standing equipment is placed directly on the turntable/ground plane. The set up of the Equipment under test will be in accordance to ANSI C63.4-2003. The Interface cables that are closer than 40 centimetres to the ground plane are bundled in the center in a serpentine fashion so they are at least 40 centimetres from the ground plane. Cables to simulators/testers (if used in this test) are routed through the center of the table and to a screen room located outside the test area. The antenna was positioned 3, 10 or 30 meters horizontally from the EuT. To locate maximum emissions from the test sample the antenna is varied in height from 1 to 4 meters, measurement scans are made with both horizontal and vertical antenna polarization's and the EuT are rotated 360 degrees.

The final level, expressed in dB μ V/m, is arrived by taking the reading from the EMI receiver (Level dB μ V) and adding the correction factors and cable loss factor (Factor dB) to it. This is done automatically in the EMI receiver, where the correction factors are stored. This result then has the FCC or CISPR limit subtracted from it to provide the Delta which gives the tabular data as shown in the data sheets at page.

The radiated emissions from the EuT are measured in the frequency range of 1 GHz to maximum frequency as specified in section 15.33, using a tuned receiver (Spectrum Analyser) and appropriate linearly polarized antennas. Table top equipment is placed on a 1.0 X 1.5 meter non-conducting table 80 centimetres above the ground plane. Floor standing equipment is placed directly on the turntable/ground plane. The set up of the Equipment under test will be in accordance to ANSI C63.4-2003.

The Interface cables that are closer than 40 centimetres to the ground plane are bundled in the center in a serpentine fashion so they are at least 40 centimetres from the ground plane. Cables to simulators/testers (if used in this test) are routed through the center of the table and to a screen room located outside the test area. The antenna was positioned 3m horizontally from the EuT.

Measurement are made in both the horizontal and vertical planes of polarization in a fully anechoic room using a spectrum analyzer with the detector function set to peak and resolution as well as video bandwidth set to 100 kHz and for any spurious emission or modulation product that falls in Restricted Band, as defined in Section 15.205, set the resolution and video bandwidth to 1 MHz.

All tests are performed at a test-distance of 3 meters. Hand-held or body-worn devices are rotated through three orthogonal axes to determine which attitude and configuration procedure the highest emission relative the limit and therefore shall be used for final testing. During the tests the EUT is rotated all around to find the maximum levels of emissions. The cables and equipment were placed and moved within the range of position likely to find their maximum emissions. When the EuT is larger than the beamwidth of the measuring antenna, the measurement antenna will be moved over the surfaces for the four sides or the test distance will be reduced to demonstrate that emissions were at maximum at the limit distance.

Analyzer Settings (EMI receiver) for spurious emissions which fall not in Restricted Band:

- Detector: Max hold
- RBW: 100 kHz for $f \geq 1\text{GHz}$, 120 kHz for $f \leq 1\text{GHz}$
- VBW: \geq RBW
- Sweep Time: Coupled
- Detector function: Peak

Analyzer Settings (EMI receiver) for spurious emissions which fall in Restricted Band:

- Detector: Max hold
- RBW: 1 MHz for $f \geq 1\text{GHz}$, 120 kHz for $f \leq 1\text{GHz}$
- VBW: \geq RBW
- Sweep Time: Coupled
- Detector function: Peak for $f \geq 1\text{GHz}$, Quasi Peak for $f \leq 1\text{GHz}$

5.3.4 Test result

Testresult in detail: (<1GHz)

Corrected field strength of fundamental wave as reference for radiated emissions:

118.7 dB μ V/m

Channel 1												
Frequency [MHz]	Restricted Band	Reading Level QP [dB μ V]	Reading Level AV [dB μ V]	Reading Level PK [dB μ V]	Bandwidth [kHz]	Correct. factor [dB]	Corrected Level QP [dB μ V/m]	Corrected Level AV [dB μ V/m]	Corrected Level PK [dB μ V/m]	Limit [dB μ V/m]		Delta [dB]
										PK	QP	
0.009-0.15					0.2		< 30					
0.15-30					9		< 30					
30-1000					120		< 30			98.7		> -60.0
30-88	■				120		< 30				40	> -10.0
88-216	■				120		< 30				43,5	> -13.5
240	■	26.1			120	14.0	40.1				46	> -5.9
960-1000	■				120		< 30				54	> -24.0

Corrected field strength of fundamental wave as reference for radiated emissions:

118.5 dB μ V/m

Channel 6												
Frequency [MHz]	Restricted Band	Reading Level QP [dB μ V]	Reading Level AV [dB μ V]	Reading Level PK [dB μ V]	Bandwidth [kHz]	Correct. factor [dB]	Corrected Level QP [dB μ V/m]	Corrected Level AV [dB μ V/m]	Corrected Level PK [dB μ V/m]	Limit [dB μ V/m]		Delta [dB]
										PK	QP	
0.009-0.15					0.2		< 30					
0.15-30					9		< 30					
30-1000					120							
30-88	■				120		< 30				40	> -10.0
88-216	■				120		< 30				43,5	> -13.5
240	■	27.7			120	14.0	41.7				46	> -4.3
960-1000	■				120		< 30				54	> -24.0

Corrected field strength of fundamental wave as reference for radiated emissions:

118.9 dB μ V/m

Channel 11												
Frequency [MHz]	Restricted Band	Reading Level QP [dB μ V]	Reading Level AV [dB μ V]	Reading Level PK [dB μ V]	Bandwidth [kHz]	Correct. factor [dB]	Corrected Level QP [dB μ V/m]	Corrected Level AV [dB μ V/m]	Corrected Level PK [dB μ V/m]	Limit [dB μ V/m]		Delta [dB]
										PK	QP	
0.009-0.15					0.2		< 30					
0.15-30					9		< 30					
30-1000					120							
30-88	■				120		< 30				40	> -10.0
88-216	■				120		< 30				43,5	> -13.5
240	■	27.4			120	14.0	41.4				46	> -4.6
960-1000	■				120		< 30				54	> -24.0

Testresult in detail:(>1GHz)

Corrected field strength of fundamental wave as reference for radiated emissions: 118.7 dB μ V/m

Channel 1											
Frequency [MHz]	Restricted Band	Reading Level PK [dB μ V]	Corr. Duty Cycle [dB]	Level AV [dB μ V] *)	Bandwidth [kHz]	Correct. Factor [dB]	Corrected Level PK [dB μ V/m]	Corrected Level AV [dB μ V/m]	Limit PK [dB μ V/m]	Limit AV [dB μ V/m]	Delta [dB]
4816	■	37.9	-		1000	0.7	38.5		74.0	54.0	-35.5
7232		36.6	-		100	7.3	43.9		98.7		-54.8
9648		39.5	-		100	6.4	45.9		98.7		-52.8

Corrected field strength of fundamental wave as reference for radiated emissions: 118.5dB μ V/m

Channel 6											
Frequency [MHz]	Restricted Band	Reading Level PK [dB μ V]	Corr. Duty Cycle [dB]	Level AV [dB μ V] *)	Bandwidth [kHz]	Correct. Factor [dB]	Corrected Level PK [dB μ V/m]	Corrected Level AV [dB μ V/m]	Limit PK [dB μ V/m]	Limit AV [dB μ V/m]	Delta [dB]
4864	■	42.3	-		1000	0.8	43.1		74.0	54.0	-30.9
7312	■	37.0	-		1000	7.5	44.5		74.0	54.0	-29.5
9760		41.4	-		100	6.5	47.9		98.5		-50.6

Corrected field strength of fundamental wave as reference for radiated emissions: 118.9 dB μ V/m

Channel 11											
Frequency [MHz]	Restricted Band	Reading Level PK [dB μ V]	Corr. Duty Cycle [dB]	Level AV [dB μ V] *)	Bandwidth [kHz]	Correct. Factor [dB]	Corrected Level PK [dB μ V/m]	Corrected Level AV [dB μ V/m]	Limit PK [dB μ V/m]	Limit AV [dB μ V/m]	Delta [dB]
4912	■	37.6	-		1000	0.9	38.5		74.0	54.0	35.5
9856		35.2	-		100	6.5	41.7		98.9		57.2

*) Average values were measured with spectrum analyzer by taking the following Settings
 RBW: 1 MHz
 VBW: 10 Hz
 Sweep: Auto

Peak-Limit according to FCC Subpart 15.247(d)

In any 100 kHz bandwidth outside the frequency band 2400 – 2483.50 MHz, the radio frequency power that is produced by the intentional radiator shall be at least 20 dB below that in the 100 kHz bandwidth within the band that contains the highest level of the desired power, based on either an RF conducted or a radiated measurement. Attenuation below the general limits specified in §15.209(a) is not required. In addition, radiated emissions which fall in the restricted bands, as defined in §15.205(a), must also comply with the radiated emission limit specified in §15.209(a) (see §15.205(c)).

Final radiated limits for spurious emissions which fall not in restricted band:

Frequency [MHz]	Limits acc. 15.209 [dBµV/m]	Measurement distance (meters)	Limits acc. 15.247(d) [dBµV/m]			Final Radiated Limits [dBµV/m]		
			Ch 1	Ch 6	Ch 11	Ch 1	Ch 6	Ch 11
	Limit							
0,009-0,490	2400/F(kHz)	300	98.72	98.51	98.92	98.72	98.51	98.92
0,490-1,705	24000/F(kHz)	30	98.72	98.51	98.92	98.72	98.51	98.92
1,705-30	30	30	98.72	98.51	98.92	98.72	98.51	98.92
30-88	40	3	98.72	98.51	98.92	98.72	98.51	98.92
88-216	43,5	3	98.72	98.51	98.92	98.72	98.51	98.92
216-960	46	3	98.72	98.51	98.92	98.72	98.51	98.92
Above 960	54	3	98.72	98.51	98.92	98.72	98.51	98.92

Radiated limits according to FCC Part 15 Subpart 15.209(a) for spurious emissions which fall in restricted band:

Frequency (MHz)	Field strength of spurious emissions		Measurement distance (meters)
	(µV/m)	dB (µV/m)	
0,009-0,490	2400/F(kHz)		300
0,490-1,705	24000/F(kHz)		30
1,705-30	30	29,5	30
30-88	100	40	3
88-216	150	43.5	3
216-960	200	46	3
Above 960	500	54	3

Restricted bands of operation:

The field strength of emissions appearing within these frequency bands shall not exceed the limits shown in §15.209

MHz	MHz	GHz
25.5 – 25.67	960 – 1240	4.5 – 5.15
37.5 – 38.25	1300 – 1427	5.35 – 5.46
73 – 74.6	1435 – 1626.5	7.25 – 7.75
74.8 – 75.2	1645.5 – 1646.5	8.025 – 8.5
108 – 121.94	1660 – 1710	9.0 – 9.2
123 – 138	1718.8 – 1722.2	9.3 – 9.5
149.9 – 150.05	2200 – 2300	10.6 – 12.7
156.52475 – 156.52525	2310 – 2390	13.25 – 13.4
156.7 – 156.9	2483.5 – 2500	14.47 – 14.5
162.0125 – 167.17	2655 – 2900	15.35 – 16.2
167.72 – 173.2	3260 – 3267	17.7 – 21.4
240 – 285	3332 – 3339	22.01 – 23.12
322 – 335.4	3345.8 – 3358	23.6 – 24.0
399.9 – 410	3600 – 4400	31.2 – 31.8
608 – 614		36.43 – 36.5

The requirements are **FULFILLED**.

Remarks: During the test, the Eut was set into normal modulation mode as intended for use.
The measurement was performed up to the 10th harmonic (25000MHz).
This test have been performed with SEW antenna which have the max. antenna gain of
5,9 dBi.

5.4 6 dB Bandwidth

For test instruments and accessories used see section 6 Part MB.

5.4.1 Description of the test location

Test location: Area 4

5.4.2 Photo documentation of the test set-up



5.4.3 Description of Measurement

The bandwidth is measured at an amplitude level reduced from the reference level by a specified ratio of -6 dB. The reference level is the level of the highest amplitude signal observed from the transmitter at either the fundamental frequency or the first-order modulation products in all typical modes of operation, including the unmodulated carrier, even if atypical. The resolution bandwidth of measuring instrument was set to a value as shown in the following table below according to ANSI C63.4-2003.

Fundamental frequency	Minimum resolution bandwidth
9 kHz to 30 MHz	1kHz
30 to 1000 MHz	10 kHz
1000 MHz to 40 GHz	100 kHz

5.4.4 Test result

Channel number	Fundamental Frequency [MHz]	6 dB BANDWIDTH (MHz)	MINIMUM LIMIT (MHz)
1	2412	11.4	0,5
6	2437	11.4	0,5
11	2462	11.7	0,5

Limit according to FCC Subpart 15.247 (a)(2)

The minimum 6 dB bandwidth shall be at least 500 kHz

The requirements are **FULFILLED**.

Remarks: For detailed test result please refer to following test protocol.

5.4.5 Test protocol

6dB Bandwidth Measurement FCC Part 15 Subpart 15.247(a)(2)

Channel 1

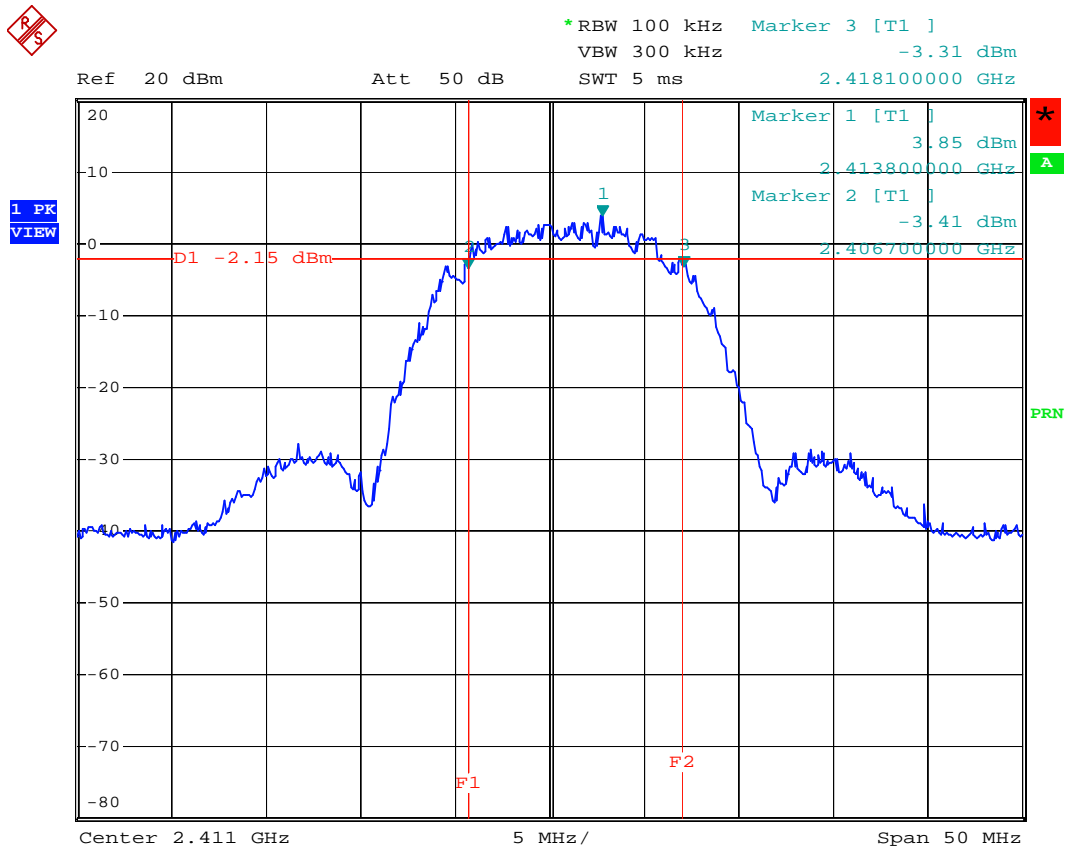

Date: 25.OCT.2005 08:55:36

6dB Bandwidth Measurement
FCC Part 15 Subpart 15.247(a)(2)

Channel 6



*RBW 100 kHz Marker 3 [T1]
VBW 300 kHz -3.61 dBm
SWT 5 ms 2.443100000 GHz

Ref 20 dBm

Att 50 dB

1 PK
VIEW

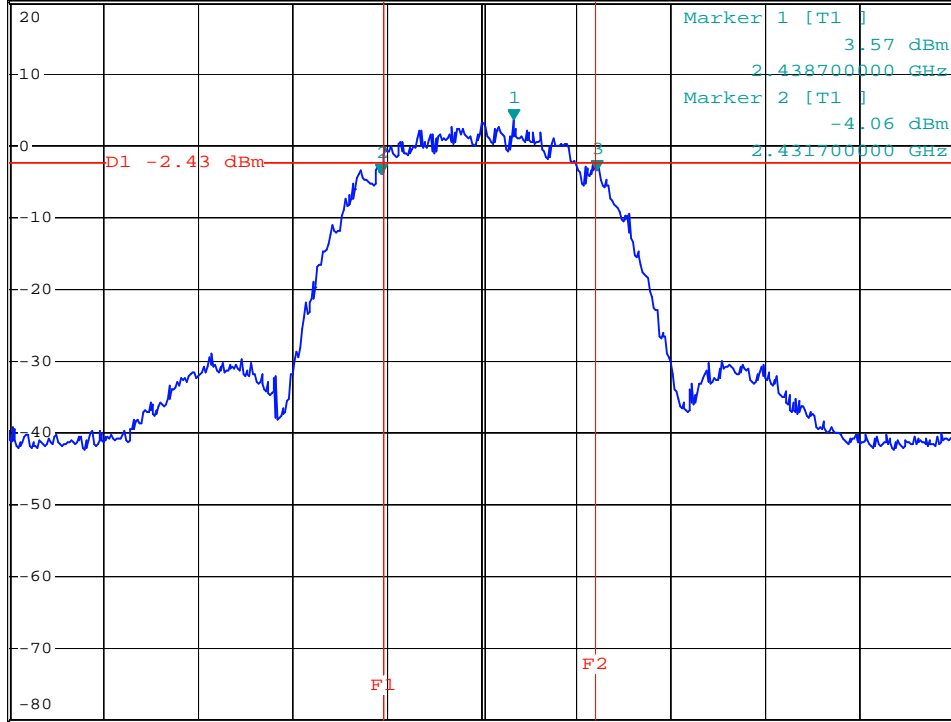

Center 2.437 GHz

5 MHz/

Span 50 MHz

Date: 25.OCT.2005 09:05:46

6dB Bandwidth Measurement FCC Part 15 Subpart 15.247(a)(2)

Channel 11

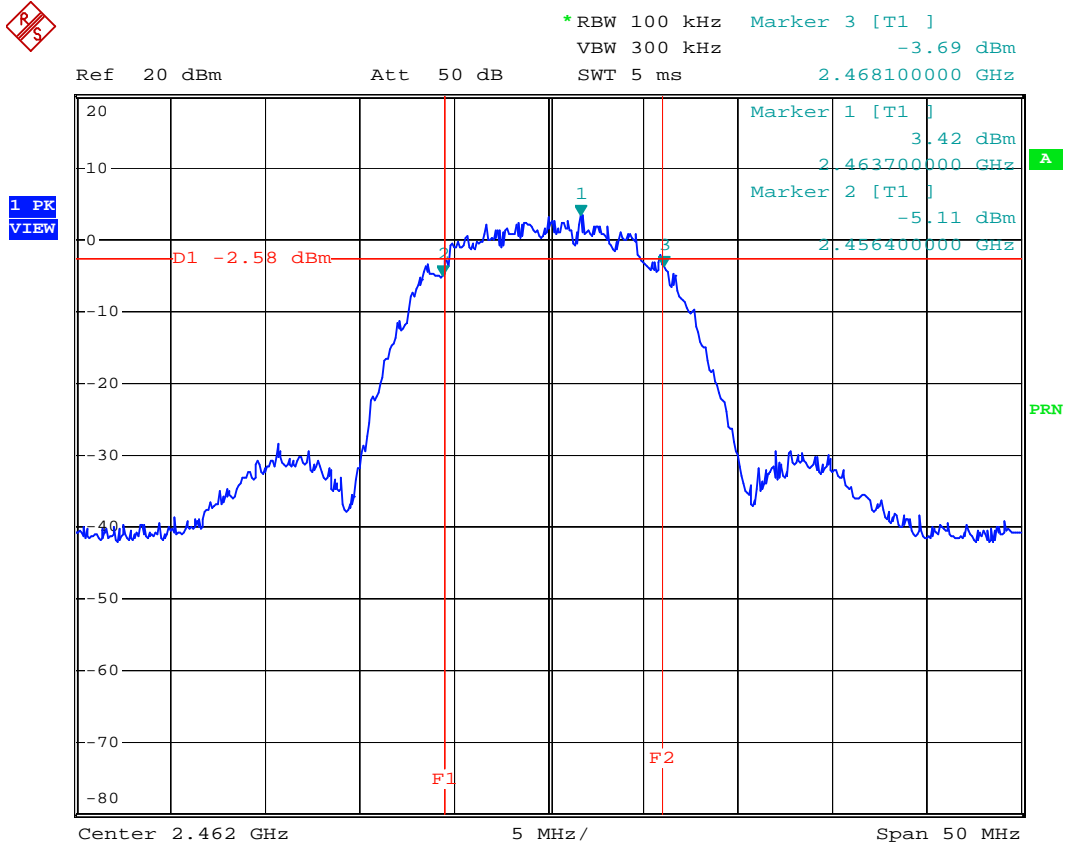

Date: 25.OCT.2005 09:08:37

5.5 Band edge test

For test instruments and accessories used see section 6 Part **SER3**

5.5.1 Description of the test location

Test location: Anechoic Chamber A2

5.5.2 Photo documentation of the test set-up



5.5.3 Description of Measurement

The EuT was connected to the spectrum analyzer with a suitable attenuator. The span of the spectrum analyzer was set wide enough to capture the peak level of the emission operating on the channel closest to the bandedge, as well as any modulation products which fall outside of the authorized band of operation. The highest amplitude appearing on spectral display was measured and it was set as the reference level for the emission mask. It was allowed the trace to stabilize and after then it was set the emission mask on the reference level to show the compliance with the bandedge requirements.

Further settings on the spectrum analyzer:

RBW: $\geq 1\%$ of the span
 VBW: \geq RBW
 Sweep: Auto
 Detector function: Peak

5.5.4 Test result

Frequency [MHz]	Peak Power Output [dB μ V]	Spurious emission read value [dB μ V]	Result of Band edge [dBc]	Band edge LIMIT [dBc]
< 2400	98.8	69.5	29.3	≥ 20.0
> 2483.5	99.5	50.0	49.5	≥ 20.0

Peak-Limit according to FCC Subpart 15.247(d)

In any 100 kHz bandwidth outside the frequency band 2400 – 2483.50 MHz, the radio frequency power that is produced by the intentional radiator shall be at least 20 dB below that in the 100 kHz bandwidth within the band that contains the highest level of the desired power, based on either an RF conducted or a radiated measurement. Attenuation below the general limits specified in §15.209(a) is not required.

In addition, radiated emissions which fall in the restricted bands, as defined in §15.205(a), must also comply with the radiated emission limit specified in §15.209(a) (see §15.205(c)).

Additional requirement according to 15.205(a) restricted band (2.4835 GHz – 2.5000 GHz)

Frequency [MHz]	Reading Level PK [dB μ V]	Corr. Duty Cycle [dB]	Level AV [dB μ V] (*)	Bandwidth [kHz]	Correct. Factor [dB]	Corrected Level PK [dB μ V/m]	Corrected Level AV [dB μ V/m]	Limit PK [dB μ V/m]	Limit AV [dB μ V/m]	Delta [dB]
2483.5	50.0	-		1000	-10.2	39.8		74.0	54.0	-34.8

The requirements are **FULFILLED**.

Remarks: For detailed test results please refer to following test protocol.

5.5.5 Test protocol

Lower Channel MHz

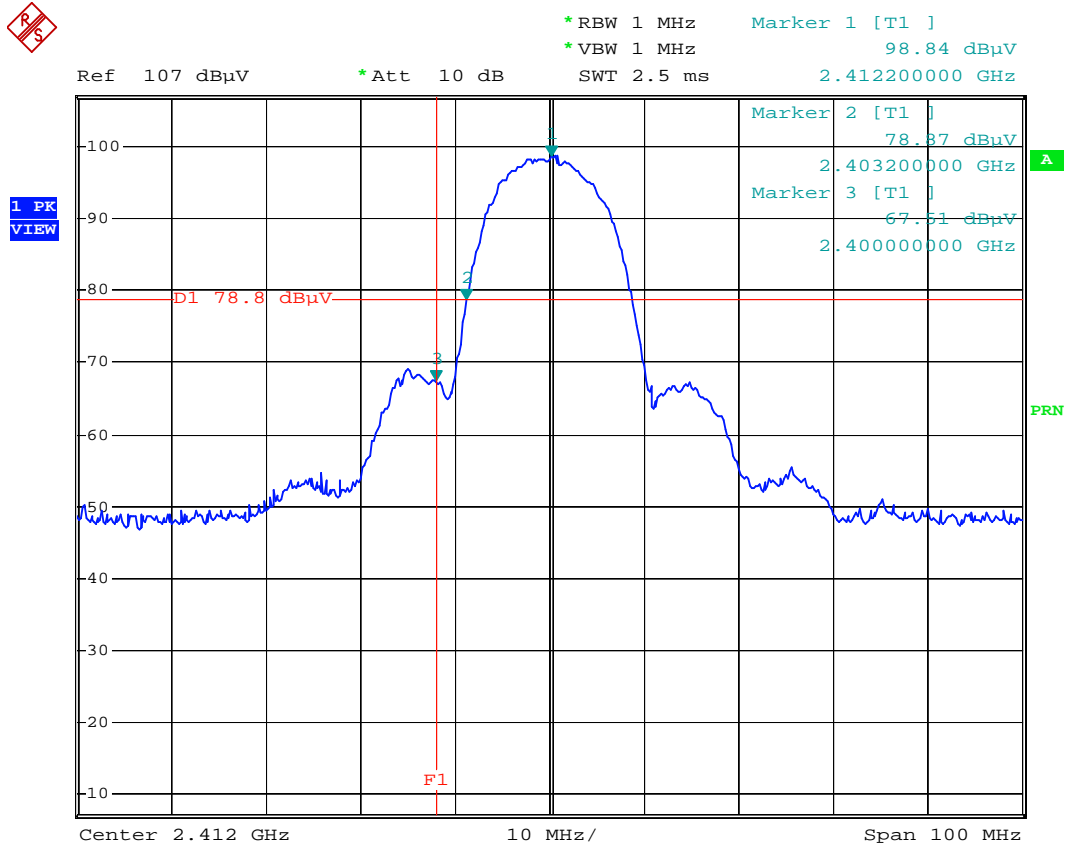

Comment: Bandedge Channel 1
 Comment: vert.
 Date: 6.NOV.2007 14:20:04

Higher Channel MHz



*RBW 1 MHz Marker 1 [T1]
 *VBW 1 MHz 99.49 dBμV
 Ref 107 dBμV *Att 10 dB SWT 2.5 ms 2.462000000 GHz

1. PK
VIEW

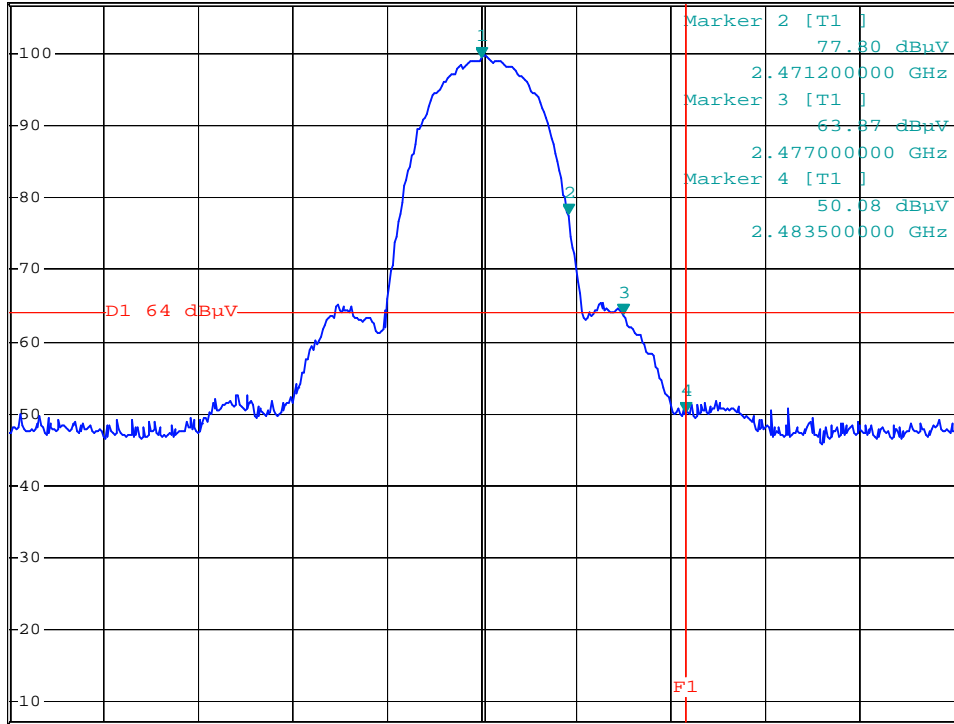

Center 2.462 GHz 10 MHz/ Span 100 MHz

Comment: Bandedge Channel 11
 Comment: vert.
 Date: 6.NOV.2007 14:15:48

Note: The display line at 64 dBμV represents the average limit according §15.205(a) 54 dBμV (+ correction)

5.6 Peak Power Density

For test instruments and accessories used see section 6 Part CPC 3.

5.6.1 Description of the test location

Test location: AREA4

5.6.2 Photo documentation of the test set-up



5.6.3 Description of Measurement

The EuT was connected to the spectrum analyzer with a suitable attenuator. The bandwidth of the fundamental frequency was measured with the spectrum analyzer using 3 kHz RBW and 30 kHz VBW, set sweep time equal to span/3 kHz. The power spectral density was measured and recorded.

Settings on the spectrum analyzer:

RBW: 3 kHz
VBW: 30 kHz
Sweep: auto
Detector function: Peak

5.6.4 Test result

Channel	Fundamental Frequency [MHz]	Peak Power density (dBm)
1	2412	-9.3
6	2437	-9.5
11	2462	-8.3

Limit according to FCC Subpart 15.247 (e)

The peak power spectral density shall not be greater than 8 dBm in any 3 kHz band.

The requirements are **FULFILLED**.

Remarks:

5.7 Correction for Pulse Operation (Duty Cycle)

For test instruments and accessories used see section 6 Part DC.

5.7.1 Description of the test location

Test location: NONE

Remarks: The measurement is not applicable, the EuT meets the limits according §15.247

without correction for pulse operation

5.8 Antenna application

5.8.1 Antenna requirements

The EuT's antenna is met the requirement of FCC part 15C section 15.203 and 15.204.

FCC part 15C section 15.247 requirement:

Systems operating in the 2400-2483,5 MHz band that are used exclusively for fixed, point to point operations may employ transmitting antennas with directional gain greater than 6 dBi provided the maximum peak output power of the intentional radiator is reduced by 1 dB for every 3 dB that the directional gain of the antenna exceeds 6 dBi.

The EuT is intended for professional use in industrial environments. The installation is done by the manufacturer and therefore a responsible technician which will be trained from the manufacturer with special training documents.

The maximum measured antenna gain of the worst case configuration is 5,9 dBi. Please refer to antenna configuration below.

Following antennas will be used with the EuT:

Type	Frequency range	Gain (typical)
IW-145	2400 – 2483.5 MHz	4 dBi
SOA 2400/360/4/20/V	2400 - 2500 MHz	4 dBi
12705195 RSF12-50 JFN S Radiating cable	2400 - 2600 MHz	0 dBi
13000810 Dual Band Antenna	2400 – 2483.5	max. 5.9 dBi

Photo documentation of the recommended Antennas:
Antenna IW-145:



Antenna SOA 2400/360/4/20/V:





Antenna 12705195 RSF12-50 JFN S Radiating cable:





13000810 Dual Band Antenna:





5.8.2 Result

Tests with all from the manufacturer recommended antenna configurations were done for evaluating the worst case. The worst case is the usage of the "13000810 Dual Band Antenna" with 5.9 dBi antenna gain regarding the EuT. All relevant measurements were done with this antenna to show the worst case in the measurement results.

This four recommended antenna configurations can be used with the EuT.

Therefore the **requirements** in this part **are fulfilled**.

Remarks: However, the installer is responsible for ensuring that the proper antenna
is employed and the limits in this part are not exceeded.

5.9 Receiver conducted disturbances 0.15 - 30 MHz

For test instruments and accessories used see section 6 Part A 4.

5.9.1 Description of the test location

Test location: NONE

Remarks: The measurement is not applicable because the EuT is battery powered.

5.10 Receiver radiated emissions 9 kHz - 40 GHz

For test instruments and accessories used see section 6 Part **SER1**, **SER2** and **SER3**.

5.10.1 Description of the test location

Test location: OATS1
Anechoic Chamber A2

Test distance: 3 metres

5.10.2 Photo documentation of the test set-up



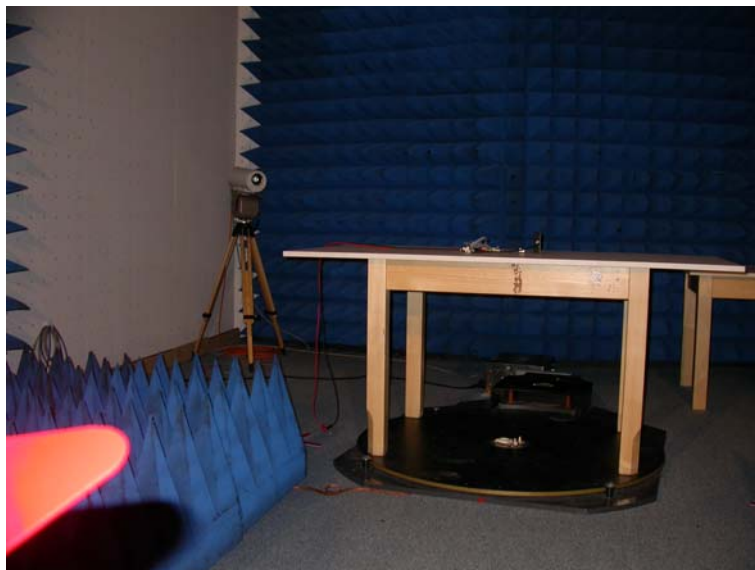
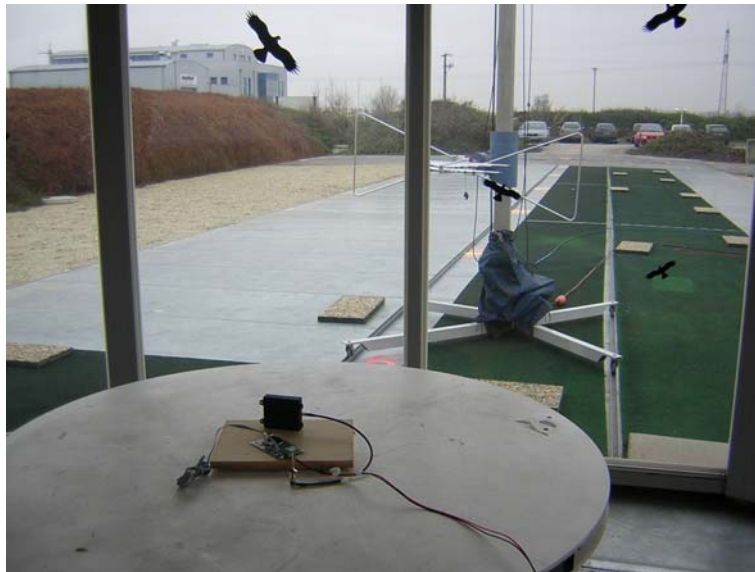

5.10.3 Description of Measurement

The spurious emissions from the EuT will be measured on an open area test site in the frequency range of 9 kHz to 30 MHz using a tuned receiver and a shielded loop antenna. The antenna was positioned 3, 10 or 30 meters horizontally from the EuT. Measurements have been made in all three orthogonal axes and the shielded loop antenna was rotated to locate the maximum of the emissions. In the case where larger measuring distances are required the results will be extrapolated based on the values measured on the closer distances according to Section 15.31 (f) (2) [2]. The final measurement will be performed with an EMI Receiver set to Quasi Peak detector except for the frequency bands 9 kHz to 90 kHz and 110 to 490 kHz where an average detector will be used according to Section 15.209 (d) [2].

The final level, expressed in dB μ V/m, is arrived at by taking the reading from the EMI receiver (Level dB μ V) and adding the antenna correction factor and cable loss factor (Factor dB) to it. This result then has to be compared with the relevant FCC limit.

The resolution bandwidth during the measurement is as follows:

9 kHz – 150 kHz: ResBW: 200 Hz

150 kHz – 30 MHz: ResBW: 9 kHz

Radiated spurious emissions from the EuT are measured in the frequency range of 30 MHz to 1000 MHz using a tuned receiver and appropriate broadband linearly polarized antennas. Measurements between 30 MHz and 1000 MHz are made with 120 kHz/6 dB bandwidth and quasi-peak detection. Table top equipment is placed on a 1.0 X 1.5 meter non-conducting table 80 centimetres above the ground plane. Floor standing equipment is placed directly on the turntable/ground plane. The set up of the Equipment under test will be in accordance to ANSI C63.4-2003. The Interface cables that are closer than 40 centimetres to the ground plane are bundled in the center in a serpentine fashion so they are at least 40 centimetres from the ground plane. Cables to simulators/testers (if used in this test) are routed through the center of the table and to a screen room located outside the test area. The antenna was positioned 3, 10 or 30 meters horizontally from the EuT. To locate maximum emissions from the test sample the antenna is varied in height from 1 to 4 meters, measurement scans are made with both horizontal and vertical antenna polarization's and the EuT are rotated 360 degrees.

The final level, expressed in dB μ V/m, is arrived by taking the reading from the EMI receiver (Level dB μ V) and adding the correction factors and cable loss factor (Factor dB) to it. This is done automatically in the EMI receiver, where the correction factors are stored. This result then has the FCC or CISPR limit subtracted from it to provide the Delta which gives the tabular data as shown in the data sheets at page.

The radiated emissions from the EuT are measured in the frequency range of 1 GHz to maximum frequency as specified in section 15.33, using a tuned receiver (Spectrum Analyser) and appropriate linearly polarized antennas. Table top equipment is placed on a 1.0 X 1.5 meter non-conducting table 80 centimetres above the ground plane. Floor standing equipment is placed directly on the turntable/ground plane. The set up of the Equipment under test will be in accordance to ANSI C63.4-2003.

The Interface cables that are closer than 40 centimetres to the ground plane are bundled in the center in a serpentine fashion so they are at least 40 centimetres from the ground plane. Cables to simulators/testers (if used in this test) are routed through the center of the table and to a screen room located outside the test area. The antenna was positioned 3m horizontally from the EuT.

Measurement are made in both the horizontal and vertical planes of polarization in a fully anechoic room using a spectrum analyzer with the detector function set to peak and resolution as well as video bandwidth set to 100 kHz and for any spurious emission or modulation product that falls in Restricted Band, as defined in Section 15.205, set the resolution and video bandwidth to 1 MHz.

All tests are performed at a test-distance of 3 meters. Hand-held or body-worn devices are rotated through three orthogonal axes to determine which attitude and configuration procedure the highest emission relative the limit and therefore shall be used for final testing. During the tests the EUT is rotated all around to find the maximum levels of emissions. The cables and equipment were placed and moved within the range of position likely to find their maximum emissions. When the EuT is larger than the beamwidth of the measuring antenna, the measurement antenna will be moved over the surfaces for the four sides or the test distance will be reduced to demonstrate that emissions were at maximum at the limit distance.

Analyzer Settings (EMI receiver) for spurious emissions which fall not in Restricted Band:

- Detector: Max hold
- RBW: 100 kHz for $f \geq 1\text{GHz}$, 120 kHz for $f \leq 1\text{GHz}$
- VBW: \geq RBW
- Sweep Time: Coupled
- Detector function: Peak

Analyzer Settings (EMI receiver) for spurious emissions which fall in Restricted Band:

- Detector: Max hold
- RBW: 1 MHz for $f \geq 1\text{GHz}$, 120 kHz for $f \leq 1\text{GHz}$
- VBW: \geq RBW
- Sweep Time: Coupled
- Detector function: Peak for $f \geq 1\text{GHz}$, Quasi Peak for $f \leq 1\text{GHz}$

5.10.4 Test result

Testresult in detail: (<1GHz)

Channel 1												
Frequency [MHz]	Reading Level QP [dB μ V]	Reading Level AV [dB μ V]	Reading Level PK [dB μ V]	Bandwidth [kHz]	Correct. factor [dB]	Corrected Level QP [dB μ V/m]	Corrected Level AV [dB μ V/m]	[Corrected Level PK [dB μ V/m]	Limit [dB μ V/m]			Delta [dB]
									QP	AV	PK	
0,009-0,15				0,2		< 30						
0,15-30				9		< 30						
30-1000				120		< 30						

Channel 6												
Frequency [MHz]	Reading Level QP [dB μ V]	Reading Level AV [dB μ V]	Reading Level PK [dB μ V]	Bandwidth [kHz]	Correct. factor [dB]	Corrected Level QP [dB μ V/m]	Corrected Level AV [dB μ V/m]	[Corrected Level PK [dB μ V/m]	Limit [dB μ V/m]			Delta [dB]
									QP	AV	PK	
0,009-0,15				0,2		< 30						
0,15-30				9		< 30						
30-1000				120		< 30						

Channel 11												
Frequency [MHz]	Reading Level QP [dB μ V]	Reading Level AV [dB μ V]	Reading Level PK [dB μ V]	Bandwidth [kHz]	Correct. factor [dB]	Corrected Level QP [dB μ V/m]	Corrected Level AV [dB μ V/m]	[Corrected Level PK [dB μ V/m]	Limit [dB μ V/m]			Delta [dB]
									QP	AV	PK	
0,009-0,15				0,2		< 30						
0,15-30				9		< 30						
30-1000				120		< 30						

Test result >1GHz

Channel 1									
Frequency [MHz]	Reading Level PK [dBµV]	Reading Level AV [dBµV] *	Bandwidth [kHz]	Correct. Factor [dB]	Corrected Level PK [dBµV/m]	Corrected Level AV [dBµV/m]	Limit PK [dBµV/m]	Limit AV [dBµV/m]	Delta [dB]
1894	52.4		1000	-12.1	40.3		74.0	54.0	-33.7
2446	51.7		1000	-10.1	41.6		74.0	54.0	-32.4

Channel 6									
Frequency [MHz]	Reading Level PK [dBµV]	Reading Level AV [dBµV] *	Bandwidth [kHz]	Correct. Factor [dB]	Corrected Level PK [dBµV/m]	Corrected Level AV [dBµV/m]	Limit PK [dBµV/m]	Limit AV [dBµV/m]	Delta [dB]
1894	52.4		1000	-12.1	40.3		74.0	54.0	-33.7
2446	51.2		1000	-10.1	41.1		74.0	54.0	-32.9

Channel 11									
Frequency [MHz]	Reading Level PK [dBµV]	Reading Level AV [dBµV] *	Bandwidth [kHz]	Correct. Factor [dB]	Corrected Level PK [dBµV/m]	Corrected Level AV [dBµV/m]	Limit PK [dBµV/m]	Limit AV [dBµV/m]	Delta [dB]
1894	55.0		1000	-12.1	42.9		74.0	54.0	-31.1
2446	50.8		1000	-10.1	40.7		74.0	54.0	-33.3

Limit according to FCC Subpart 15.109(a)

Frequency of emission [MHz]	Field strength Limits [µV/m]	Field strength Limits [dBµV/m]
0,009-0,490	2400/F(kHz)	
0,490-1,705	24000/F(kHz)	
1,705-30	30	
30-88	100	40
88-216	150	44
216-960	200	46
Above 960	500	54

The requirements are **FULFILLED**.

Remarks: During the test, the Eut was set into continuous receiving mode.
The measurement was performed up to the 5th harmonic (13000 MHz).

5.11 Maximum Permissible Exposure (MPE)

For test instruments and accessories used see section 6 Part **CPC3**.

5.11.1 Description of the test location

Test location: AREA4

5.11.2 Photo documentation of the test set-up



5.11.3 Calculation of MPE

Conducted maximum output power:

a) Frequency range from 2400.0 to 2483.5 MHz: 11.9 dBm

The conducted output power has been measured at the input to the antenna with the maximum power setting of the WLAN-Modul.

For MPE-Calculation the following formula has been used:

$$\text{Friis transmission formula: } P_d = \frac{P_{out} * G}{4 * \pi * r^2}$$

Limit according §1.1310 table 1, Limit for **Maximum Permissible Exposure**

Frequency range from 2400 to 2483.5 MHz

Limit for general population / uncontrolled exposures: **1.0 mW/cm²**

Result:

Maximum output power to the antenna: $P_{out} = 15.48 \text{ mW (11.9 dBm)}$

Power density: $P_d = 0.148 \text{ mW/cm}^2 \text{ (-8.3 dBm)}$

Antenna gain: $G = 3.89 \text{ (5.9 dBi, worst case)}$

Calculation the distance r: $r = 5.7 \text{ cm}$
 $r < 20 \text{ cm}$

The EuT is according to FCC Rules 47CFR 2.1093(b) no portable device and is designed to be used that radiating structures are outside of 20 cm of the body of the user.

The requirements for a non harmful use are **FULFILLED**.

Remarks:

6 USED TEST EQUIPMENT AND ACCESSORIES

All test instruments used, in addition to the test accessories, are calibrated and verified regularly.

The calibration intervals and the calibration history will be given out on request.

Test ID	Model / Type	Kind of Equipment	Manufacturer	Equipment No.
CPC 3	FSP 30	Spectrum Analyzer	Rohde & Schwarz München	02-02/11-05-001
	THS730A	Handheld Scope	Tektronix GmbH	02-02/13-05-001
	HM-8142	Power Supply	A.H.-Systems Inc.	02-02/50-05-047
CPR 3	FSP 30	Spectrum Analyzer	Rohde & Schwarz München	02-02/11-05-001
	AFS4-01000400-10-10P-4	RF Amplifier 1-4 GHz	PARZICH GMBH	02-02/17-05-003
	AMF-4F-04001200-15-10P	RF Amplifier 4-12 GHz	PARZICH GMBH	02-02/17-05-004
	AFS5-12001800-18-10P-6	RF Amplifier 12-18 GHz	PARZICH GMBH	02-02/17-06-002
	3117	Horn Antenna 1-18 GHz	EMCO Elektronik GmbH	02-02/24-05-009
	Sucoflex N-1600-SMA	RF Cable	novotronik Signalverarbeitung	02-02/50-05-073
Sucoflex N-2000-SMA	RF Cable	novotronik Signalverarbeitung	02-02/50-05-075	
MB	FSP 30	Spectrum Analyzer	Rohde & Schwarz München	02-02/11-05-001
	THS730A	Handheld Scope	Tektronix GmbH	02-02/13-05-001
	WK-340/40	Climatic Chamber	Weiss Umwelttechnik GmbH	02-02/45-05-001
	HM-8142	Power Supply	A.H.-Systems Inc.	02-02/50-05-047
SER 1	FMZB 1516	Magnetic Field Antenna	Schwarzbeck Mess-Elektron	01-02/24-01-018
	ESCI	EMI Test Receiver	Rohde & Schwarz München	02-02/03-05-005
	S10162-B/+11N-50-10-5/+1	RF Cable 33m	Huber + Suhner	02-02/50-05-031
	KK-EF393-21N-16	RF Cable 20m	Huber + Suhner	02-02/50-05-033
	NW-2000-NB	RF Cable	Huber + Suhner	02-02/50-05-113
SER 2	ESVS 30	EMI Test Receiver	Rohde & Schwarz München	02-02/03-05-006
	VULB 9168	Trilog-Broadband Anten	Schwarzbeck Mess-Elektron	02-02/24-05-005
	S10162-B/+11N-50-10-5/+1	RF Cable 33m	Huber + Suhner	02-02/50-05-031
	KK-EF393-21N-16	RF Cable 20m	Huber + Suhner	02-02/50-05-033
	NW-2000-NB	RF Cable	Huber + Suhner	02-02/50-05-113
SER 3	AFS4-01000400-10-10P-4	RF Amplifier 1-4 GHz	PARZICH GMBH	02-02/17-05-003
	AMF-4F-04001200-15-10P	RF Amplifier 4-12 GHz	PARZICH GMBH	02-02/17-05-004
	AFS5-12001800-18-10P-6	RF Amplifier 12-18 GHz	PARZICH GMBH	02-02/17-06-002
	3117	Horn Antenna 1-18 GHz	EMCO Elektronik GmbH	02-02/24-05-009
	Sucoflex N-1600-SMA	RF Cable	novotronik Signalverarbeitung	02-02/50-05-073

Equipment No.	Next Calib.	Last Calib.	Next Verif.	Last Verif.
02-02/11-05-001	12.06.2007	12.06.2006		
02-02/13-05-001	09.03.2008	09.03.2007		
02-02/50-05-047				
02-02/11-05-001	12.06.2007	12.06.2006		
02-02/17-05-003				
02-02/17-05-004				
02-02/17-06-002				
02-02/24-05-009	12/15/2007	12/15/2006		
02-02/50-05-073				
02-02/50-05-075				
02-02/11-05-001	12.06.2007	12.06.2006		
02-02/13-05-001	09.03.2008	09.03.2007		
02-02/45-05-001	09.01.2008	09.01.2005	12.06.2007	06.06.2007
02-02/50-05-047				
01-02/24-01-018	12.04.2007	12.04.2006		
02-02/03-05-005	06.11.2008	06.11.2007		
02-02/50-05-031				
02-02/50-05-033				
02-02/50-05-113				
02-02/03-05-006	07/24/2008	07/24/2007		
02-02/24-05-005	04/15/2008	04/15/2005	09/21/2008	09/21/2007
02-02/50-05-031				
02-02/50-05-033				
02-02/50-05-113				
02-02/17-05-003				
02-02/17-05-004				
02-02/17-06-002				
02-02/24-05-009	12/15/2007	12/15/2006		
02-02/50-05-073				