

A Test Lab Techno Corp.

Changan Lab : No. 140-1, Changan Street, Bade District, Taoyuan City 33465, Taiwan (R.O.C).

Tel : 886-3-271-0188 / Fax : 886-3-271-0190

SAR EVALUATION REPORT



Test Report No.	: 1612FS13
Applicant	: Daviscomms (S) Pte Ltd
Applicant Address	: Blk 70 Ubi Crescent #01-07, Ubi Techpark 408570 Singapore
Product Type	: POCSAG ALPHANUMERIC PAGER with 3G/GSM, GPS & Wi-Fi
Trade Name	: DAVISCOMMS
Model Number	: BR828PGTW
Date of Received	: Oct. 14, 2016
Test Period	: Nov. 23 ~ Dec. 05, 2016
Date of Issued	: Dec. 20, 2016
Test Environment	: Ambient Temperature : 22 ± 2 °C Relative Humidity : 40 - 70 %
Standard	: ANSI/IEEE C95.1-1992 / IEEE Std. 1528-2013 47 CFR Part §2.1093 KDB 865664 D01 v01r04 / KDB 865664 D02 v01r02 KDB 447498 D01 v06 / KDB 248227 D01 v02r02 KDB 941225 D01 v03r01 / KDB 941225 D07 v01r02
Test Lab Location	: Chang-an Lab



1. The test operations have to be performed with cautious behavior, the test results are as attached.
2. The test results are under chamber environment of A Test Lab Techno Corp. A Test Lab Techno Corp. does not assume responsibility for any conclusions and generalizations drawn from the test results with regard to other specimens or samples.
3. The measurement report has to be written approval of A Test Lab Techno Corp. It may only be reproduced or published in full. This report shall not be reproduced except in full, without the written approval of A Test Lab Techno Corp. The test results in the report only apply to the tested sample.

Approved By :

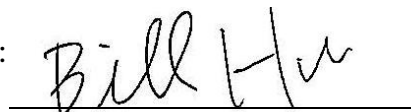
(Bill Hu)

Tested By :

(Mark Duan)



Contents

1. Summary of Maximum Reported SAR Value.....	4
2. Description of Equipment under Test (EUT)	5
3. Introduction.....	6
3.1 SAR Definition	6
4. SAR Measurement Setup	7
4.1 DASy E-Field Probe System.....	8
4.2 Data Acquisition Electronic (DAE) System.....	11
4.3 Robot.....	11
4.4 Measurement Server.....	11
4.5 Device Holder.....	12
4.6 Oval Flat Phantom - ELI 4.0.....	12
4.7 Data Storage and Evaluation	13
5. Tissue Simulating Liquids.....	15
5.1 Ingredients.....	16
5.2 Recipes.....	16
5.3 Liquid Depth	17
6. SAR Testing with RF Transmitters	18
6.1 SAR Testing with GSM/GPRS/EGPRS Transmitters	18
6.2 SAR Testing with WCDMA Transmitters	18
6.3 SAR Testing with HSDPA Transmitters	18
6.4 SAR Testing with 802.11 Transmitters.....	21
6.5 Conducted Power.....	22
6.6 Antenna location.....	27
6.7 Stand-alone SAR Evaluate.....	28
6.8 Simultaneous Transmitting Evaluate.....	29
6.9 SAR test reduction according to KDB	30
7. System Verification and Validation	31
7.1 Symmetric Dipoles for System Verification	31
7.2 Liquid Parameters	32
7.3 Verification Summary	34
7.4 Validation Summary	35
8. Test Equipment List.....	36
9. Measurement Uncertainty	37
10. Measurement Procedure.....	40
10.1 Spatial Peak SAR Evaluation.....	40
10.2 Area & Zoom Scan Procedures	41
10.3 Volume Scan Procedures.....	41
10.4 SAR Averaged Methods	41
10.5 Power Drift Monitoring.....	41



11. SAR Test Results Summary	42
11.1 Head Measurement SAR	42
11.2 Body Measurement SAR.....	43
11.3 Hot-spot mode Measurement SAR	44
11.4 Extremity Measurement SAR.....	44
11.5 Std. C95.1-1992 RF Exposure Limit	44
12. References	45
Appendix A - System Performance Check.....	46
Appendix B - SAR Measurement Data.....	52
Appendix C - Calibration.....	79



1. Summary of Maximum Reported SAR Value

Equipment Class	Mode	Highest Reported			
		Head SAR _{1g} (W/kg)	Body-Worn SAR _{1g} (W/kg)	Body-Worn stand alone SAR _{1g} (0.5 cm) (W/kg)	Hotspot SAR _{1g} (W/kg)
PCB	GSM 850	0.02	N/A	0.71	N/A
	GSM 1900	0.00	N/A	0.61	N/A
	WCDMA Band II	0.01	N/A	0.42	N/A
	WCDMA Band V	0.05	N/A	0.38	N/A
DTS	2.4GHz WLAN	N/A	N/A	N/A	N/A
Highest Simultaneous Transmission SAR		Head (W/kg)	Body-Worn (W/kg)	Body-Worn stand alone SAR _{1g} (0.5 cm) (W/kg)	Hotspot (W/kg)
N/A		N/A	N/A	N/A	N/A

NOTE: 1. The N/A is EUT not apply to the assessment of the exposure conditions.

2. The test procedures, as described in American National Standards, Institute ANSI/IEEE C95.1 were employed and they specify the maximum exposure limit of Head & Body is SAR_{1g} 1.6 W/kg of tissue for portable devices being used within 20cm between user and EUT in the uncontrolled environment. A description of the product and operating configuration, detailed summary of the test results, methodology and procedures used in the equipment used are included within this test report.
3. The EUT battery have be fully charged and checked periodically during the test to ascertain uniform power output.
4. The DTS stand-alone SAR evaluation is exempt.
5. This device does not support simultaneous transmission.



2. Description of Equipment under Test (EUT)

Applicant	Daviscomms (S) Pte Ltd Blk 70 Ubi Crescent #01-07, Ubi Techpark 408570 Singapore		
Manufacture	Daviscomms (Malaysia) Sdn Bhd Plot 18, Lorong Perusahaan Maju 1, Kawasan Perusahaan Perai 4, 13600 Perai, Malaysia		
Product Type	POCSAG ALPHANUMERIC PAGER with 3G/GSM, GPS & Wi-Fi		
Trade Name	DAVISCOMMS		
Model Number	BR828PGTW		
FCC ID	VDQ828-02		
IMEI No.	352253062755292		
RF Function	Band	Operate Frequency (MHz)	
	GSM/GPRS/EGPRS 850	824.2 - 848.8	
	GSM/GPRS/EGPRS 1900	1850.2 - 1909.8	
	WCDMA(RMC 12.2K) / HSDPA / HSUPA Band II	1852.4 - 1907.6	
	WCDMA (RMC 12.2K) / HSDPA / HSUPA Band V	826.4 - 846.6	
	IEEE 802.11b / 802.11g / 802.11n 2.4GHz 20MHz	2412 - 2462	
	*GPRS/EGPRS Multi Class: 12		
RF Conducted Power (Avg.)	Band	Power	
		W	dBm
	GSM/GPRS/EGPRS 850	2.037	33.09
	GSM/GPRS/EGPRS 1900	1.119	30.49
	WCDMA(RMC 12.2K) / HSDPA / HSUPA Band II	0.231	23.64
	WCDMA (RMC 12.2K) / HSDPA / HSUPA Band V	0.231	23.64
	IEEE 802.11b	0.005	7.33
	IEEE 802.11g	0.007	8.48
IEEE 802.11n 2.4GHz 20MHz	0.007	8.47	
Antenna Type	Internal Antenna		
Battery Option	Standard		
	Battery (1) Trade Name: SHINERGY (FAR EAST) CO., LTD Model: SHIN822757 Spec: DC 3.7V / 1320mAh Battery (2) Trade Name: Shida Battery Technology Co., Ltd Model: BAT-000009-1-0 Spec: DC 3.7V / 1320mAh		
Device Category	Portable Device		
Application Type	Certification		

Note: The above EUT's information was declared by manufacturer. Please refer to the specifications or user's manual for more detailed description.

3. Introduction

The A Test Lab Techno Corp. has performed measurements of the maximum potential exposure to the user of **Daviscomms (S) Pte Ltd Trade Name : DAVISCOMMS Model(s) : BR828PGTW** . The test procedures, as described in American National Standards, Institute C95.1-1999 [1] were employed and they specify the maximum exposure limit of 1.6mW/g as averaged over any 1 gram of tissue for portable devices being used within 20cm between user and EUT in the uncontrolled environment. A description of the product and operating configuration, detailed summary of the test results, methodology and procedures used in the equipment used are included within this test report.

3.1 SAR Definition

Specific Absorption Rate (SAR) is defined as the time derivative (rate) of the incremental energy (dw) absorbed by (dissipated in) an incremental mass (dm) contained in a volume element (dv) of a given density (ρ). It is also defined as the rate of RF energy absorption per unit mass at a point in an absorbing body (see Figure 2).

$$\text{SAR} = \frac{d}{dt} \left(\frac{dw}{dm} \right) = \frac{d}{dt} \left(\frac{dw}{\rho dv} \right)$$

Figure 2. SAR Mathematical Equation

SAR is expressed in units of Watts per kilogram (W/kg)

$$\text{SAR} = \frac{\sigma E^2}{\rho}$$

Where :

- σ = conductivity of the tissue (S/m)
- ρ = mass density of the tissue (kg/m³)
- E = RMS electric field strength (V/m)

*Note :

The primary factors that control rate of energy absorption were found to be the wavelength of the incident field in relations to the dimensions and geometry of the irradiated organism, the orientation of the organism in relation to the polarity of field vectors, the presence of reflecting surfaces, and whether conductive contact is made by the organism with a ground plane [2]

4. SAR Measurement Setup

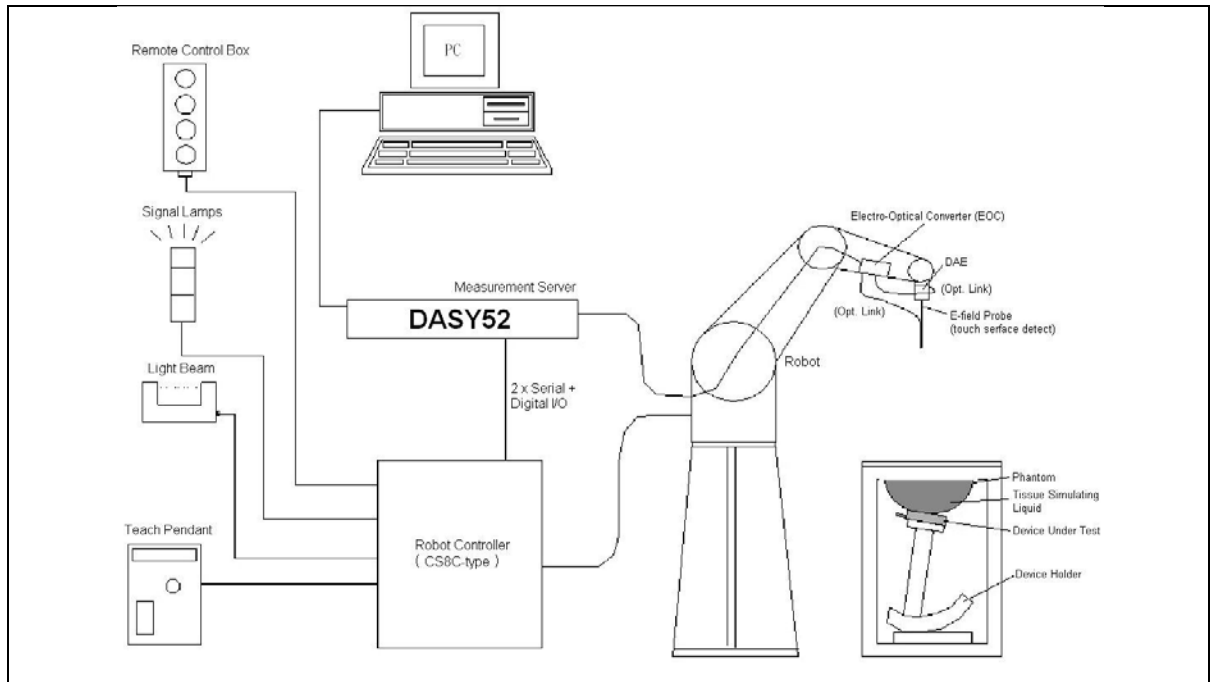

The DASY52 system for performing compliance tests consists of the following items:

1. A standard high precision 6-axis robot (Stäubli TX family) with controller, teach pendant and software. An arm extension for accommodating the data acquisition electronics (DAE).
2. A dosimetric probe, i.e., an isotropic E-field probe optimized and calibrated for usage in tissue simulating liquid. The probe is equipped with an optical surface detector system.
3. A data acquisition electronics (DAE) which performs the signal amplification, signal multiplexing, AD-conversion, offset measurements, mechanical surface detection, collision detection, etc. The unit is battery powered with standard or rechargeable batteries. The signal is optically transmitted to the EOC.
4. The function of the measurement server is to perform the time critical tasks such as signal filtering, control of the robot operation and fast movement interrupts.
5. A probe alignment unit which improves the (absolute) accuracy of the probe positioning.
6. A computer operating Windows 2000 or Windows XP.
7. DASY52 software.
8. Remote controls with teach pendant and additional circuitry for robot safety such as warning lamps, etc.
9. The SAM twin phantom enabling testing left-hand and right-hand usage.
10. The device holder for handheld mobile phones.
11. Tissue simulating liquid mixed according to the given recipes.
12. Validation dipole kits allowing validating the proper functioning of the system.



4.1 DASYS E-Field Probe System

The SAR measurements were conducted with the dosimetric probe (manufactured by SPEAG), designed in the classical triangular configuration [3] and optimized for dosimetric evaluation. The probe is constructed using the thick film technique; with printed resistive lines on ceramic substrates. The probe is equipped with an optical multi-fiber line ending at the front of the probe tip. It is connected to the EOC box on the robot arm and provides an automatic detection of the phantom surface. Half of the fibers are connected to a pulsed infrared transmitter, the other half to a synchronized receiver. As the probe approaches the surface, the reflection from the surface produces a coupling from the transmitting to the receiving fibers. This reflection increases first during the approach, reaches maximum and then decreases. If the probe is flatly touching the surface, the coupling is zero. The distance of the coupling maximum to the surface is independent of the surface reflectivity and largely independent of the surface to probe angle. The DASYS software reads the reflection during a software approach and looks for the maximum using a 2nd order fitting. The approach is stopped when reaching the maximum.

4.1.1 E-Field Probe Specification

Construction	Symmetrical design with triangular core Built-in shielding against static charges PEEK enclosure material (resistant to organic solvents, e.g., DGBE)
Calibration	ISO/IEC 17025 calibration service available
Frequency	10 MHz to > 6 GHz Linearity: ± 0.2 dB (30 MHz to 6 GHz)
Directivity	± 0.3 dB in brain tissue (rotation around probe axis) ± 0.5 dB in brain tissue (rotation normal probe axis)
Dimensions	Overall length: 337 mm (Tip: 20 mm) Tip diameter: 2.5 mm (Body: 12 mm) Typical distance from probe tip to dipole centers: 1 mm



Figure 3. E-field Probe

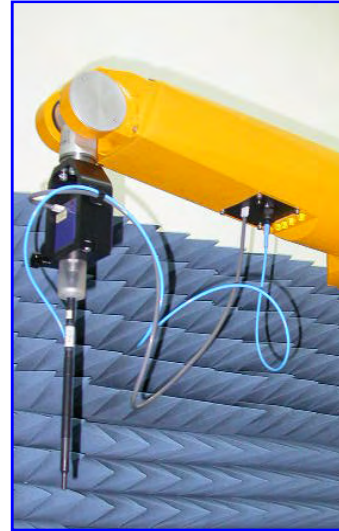

Figure 4. Probe setup on robot



4.1.2 E-Field Probe Calibration process

Dosimetric Assessment Procedure

Each E-Probe/Probe Amplifier combination has unique calibration parameters. A TEM cell calibration procedure is conducted to determine the proper amplifier settings to enter in the probe parameters. The amplifier settings are determined for a given frequency by subjecting the probe to a known E-field density (1 mW/cm²) using an RF Signal generator, TEM cell, and RF Power Meter.

Free Space Assessment

The free space E-field from amplified probe outputs is determined in a test chamber. This calibration can be performed in a TEM cell if the frequency is below 1 GHz and in a waveguide or other methodologies above 1 GHz for free space. For the free space calibration, the probe is placed in the volumetric center of the cavity and at the proper orientation with the field. The probe is rotated 360 degrees until the three channels show the maximum reading. The power density readings equates to 1 mW/cm².

Temperature Assessment

E-field temperature correlation calibration is performed in a flat phantom filled with the appropriate simulated head tissue. The E-field in the medium correlates with the temperature rise in the dielectric medium. For temperature correlation calibration a RF transparent thermistor-based temperature probe is used in conjunction with the E-field probe.

$$SAR = C \frac{\Delta T}{\Delta t}$$

Where :

Δt = Exposure time (30 seconds),

C = Heat capacity of tissue (head or body),

ΔT = Temperature increase due to RF exposure.

$$\text{Or } SAR = \frac{|E|^2 \sigma}{\rho}$$

Where :

σ = Simulated tissue conductivity,

ρ = Tissue density (kg/m³).



4.2 Data Acquisition Electronic (DAE) System

Model : DAE3, DAE4
Construction : Signal amplifier, multiplexer, A/D converter and control logic. Serial optical link for communication with DASY4/5 embedded system (fully remote controlled). Two step probe touch detector for mechanical surface detection and emergency robot stop.
Measurement Range : -100 to +300 mV (16 bit resolution and two range settings: 4mV, 400mV)
Input Offset Voltage : < 5 μ V (with auto zero)
Input Bias Current : < 50 fA
Dimensions : 60 x 60 x 68 mm

4.3 Robot

Positioner : Stäubli Unimation Corp. Robot Model: TX90XL
Repeatability : \pm 0.02 mm
No. of Axis : 6

4.4 Measurement Server

Processor : PC/104 with a 400MHz intel ULV Celeron
I/O-board : Link to DAE4 (or DAE3)
16-bit A/D converter for surface detection system
Digital I/O interface
Serial link to robot
Direct emergency stop output for robot

4.5 Device Holder

The DASY device holder is constructed of low-loss POM material having the following dielectric parameters: relative permittivity $\epsilon=3$ and loss tangent $\delta=0.02$. The amount of dielectric material has been reduced in the closest vicinity of the device, since measurements have suggested that the influence of the clamp on the test results could thus be lowered.

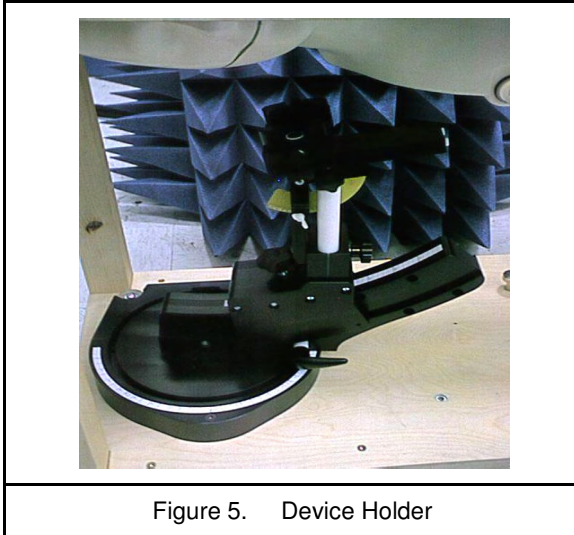

4.6 Oval Flat Phantom - ELI 4.0

The shell corresponds to the specifications of the Specific Anthropomorphic Mannequin (Oval Flat) phantom defined in IEEE 1528-2013, CENELEC 50361 and IEC 62209. It enables the dosimetric evaluation of wireless portable device usage as well as body mounted usage at the flat phantom region. A cover prevents evaporation of the liquid. Reference markings on the phantom allow the complete setup of all predefined phantom positions and measurement grids by manually teaching three points with the robot.

Shell Thickness	2 ±0.2 mm
Filling Volume	Approx. 30 liters
Dimensions	190×600×400 mm (H×L×W)
Table 1. Specification of ELI 4.0	

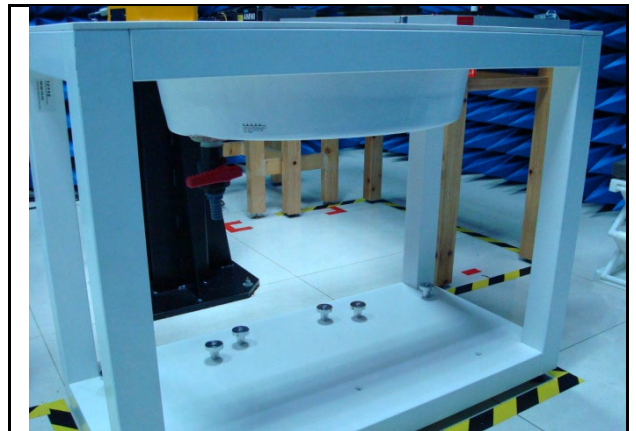

Figure 6. Oval Flat Phantom



4.7 Data Storage and Evaluation

4.7.1 Data Storage

The DASY software stores the assessed data from the data acquisition electronics as raw data (in microvolt readings from the probe sensors), together with all the necessary software parameters for the data evaluation (probe calibration data, liquid parameters and device frequency and modulation data) in measurement files with the extension DA4 or DA5. The post processing software evaluates the desired unit and format for output each time the data is visualized or exported. This allows verification of the complete software setup even after the measurement and allows correction of erroneous parameter settings. For example, if a measurement has been performed with an incorrect crest factor parameter in the device setup, the parameter can be corrected afterwards and the data can be reevaluated.

4.7.2 Data Evaluation

The DASY post processing software (SEMCAD) automatically executes the following procedures to calculate the field units from the microvolt readings at the probe connector. The parameters used in the evaluation are stored in the configuration modules of the software :

- Probe parameters : - Sensitivity $Norm_i, ai0, ai1, ai2$
- Conversion factor $ConvFi$
- Diode compression point dcp_i
- Device parameters : - Frequency f
- Crest factor cf
- Media parameters : - Conductivity σ
- Density ρ

These parameters must be set correctly in the software. They can be found in the component documents or they can be imported into the software from the configuration files issued for the DASY components. In the direct measuring mode of the multimeter option, the parameters of the actual system setup are used. In the scan visualization and export modes, the parameters stored in the corresponding document files are used.

The first step of the evaluation is a linearization of the filtered input signal to account for the compression characteristics of the detector diode. The compensation depends on the input signal, the diode type and the DC-transmission factor from the diode to the evaluation electronics. If the exciting field is pulsed, the crest factor of the signal must be known to correctly compensate for peak power. The formula for each channel can be given as :

$$V_i = U_i + U_i^2 \cdot \frac{cf}{dcp_i}$$

- With V_i = compensated signal of channel i (i = x, y, z)
 U_i = input signal of channel i (i = x, y, z)
 cf = crest factor of exciting field (DASY parameter)
 dcp_i = diode compression point (DASY parameter)



From the compensated input signals the primary field data for each channel can be evaluated :

$$E\text{-field probes : } E_i = \sqrt{\frac{V_i}{\text{Norm}_i \cdot \text{ConvF}}}$$

$$H\text{-field probes : } H_i = \sqrt{V_i} \cdot \frac{a_{i0} + a_{i1}f + a_{i2}f^2}{f}$$

- with V_i = compensated signal of channel i (i = x, y, z)
- Norm_i = sensor sensitivity of channel i (i = x, y, z)
- $\mu V/(V/m)^2$ for E-field Probes
- ConvF = sensitivity enhancement in solution
- a_{ij} = sensor sensitivity factors for H-field probes
- f = carrier frequency [GHz]
- E_i = electric field strength of channel i in V/m
- H_i = magnetic field strength of channel i in A/m

The RSS value of the field components gives the total field strength (Hermitian magnitude) :

$$E_{tot} = \sqrt{E_x^2 + E_y^2 + E_z^2}$$

The primary field data are used to calculate the derived field units.

$$SAR = E_{tot}^2 \cdot \frac{\sigma}{\rho \cdot 1000}$$

- with SAR = local specific absorption rate in mW/g
- E_{tot} = total field strength in V/m
- σ = conductivity in [mho/m] or [Siemens/m]
- ρ = equivalent tissue density in g/cm³

* Note : That the density is set to 1, to account for actual head tissue density rather than the density of the tissue simulating liquid.

The power flow density is calculated assuming the excitation field to be a free space field.

$$P_{pwe} = \frac{E_{tot}^2}{3770} \quad \text{or} \quad P_{pwe} = \frac{H_{tot}^2}{37.7}$$

- with P_{pwe} = equivalent power density of a plane wave in mW/cm²
- E_{tot} = total electric field strength in V/m
- H_{tot} = total magnetic field strength in A/m



5. Tissue Simulating Liquids

The mixture is calibrated to obtain proper dielectric constant (permittivity) and conductivity of the tissue.

The dielectric parameters of the liquids were verified prior to the SAR evaluation using an 85070C Dielectric Probe Kit and an E5071B Network Analyzer.

IEEE SCC-34/SC-2 in 1528 recommended Tissue Dielectric Parameters

The head tissue dielectric parameters recommended by the IEEE SCC-34/SC-2 in 1528 have been incorporated in the following table. These head parameters are derived from planar layer models simulating the highest expected SAR for the dielectric properties and tissue thickness variations in human head. Other head and body tissue parameters that have not been specified in 1528 are derived from the tissue dielectric parameters computed from the 4-Cole-Cole equation and extrapolated according to the head parameter specified in 1528.

Target Frequency	Head		Body	
(MHz)	ϵ_r	σ (S/m)	ϵ_r	σ (S/m)
150	52.3	0.76	61.9	0.80
300	45.3	0.87	58.2	0.92
450	43.5	0.87	56.7	0.94
835	41.5	0.90	55.2	0.97
900	41.5	0.97	55.0	1.05
915	41.5	0.98	55.0	1.06
1450	40.5	1.20	54.0	1.30
1610	40.3	1.29	53.8	1.40
1800 - 2000	40.0	1.40	53.3	1.52
2450	39.2	1.80	52.7	1.95
3000	38.5	2.40	52.0	2.73
5800	35.3	5.27	48.2	6.00
(ϵ_r = relative permittivity, σ = conductivity and $\rho = 1000 \text{ kg/m}^3$)				

Table 2. Tissue dielectric parameters for head and body phantoms



5.1 Ingredients

The following ingredients are used:

- Water: deionized water (pure H₂O), resistivity ≥ 16 M Ω -as basis for the liquid
- Sugar: refined white sugar (typically 99.7 % sucrose, available as crystal sugar in food shops)
-to reduce relative permittivity
- Salt: pure NaCl -to increase conductivity
- Cellulose: Hydroxyethyl-cellulose, medium viscosity (75-125 mPa.s, 2% in water, 20 °C), CAS # 54290 -to increase viscosity and to keep sugar in solution.
- Preservative: Preventol D-7 Bayer AG, D-51368 Leverkusen, CAS # 55965-84-9 -to prevent the spread of bacteria and molds
- DGBE: Diethylenglycol-monobutyl ether (DGBE), Fluka Chemie GmbH, CAS # 112-34-5 -to reduce relative permittivity

5.2 Recipes

The following tables give the recipes for tissue simulating liquids to be used in different frequency bands.

Note: The goal dielectric parameters (at 22 °C) must be achieved within a tolerance of ±5% for ε and ±5% for σ.

Ingredients (% by weight)	Frequency (MHz)												Frequency (GHz)	
	750		835		1750		1900		2450		2600		5GHz	
Tissue Type	Head	Body	Head	Body	Head	Body	Head	Body	Head	Body	Head	Body	Head	Body
Water	39.28	51.30	41.45	52.40	54.50	40.20	54.90	40.40	62.70	73.20	60.30	71.40	65.5	78.6
Salt (NaCl)	1.47	1.42	1.45	1.50	0.17	0.49	0.18	0.50	0.50	0.10	0.60	0.20	0.00	0.00
Sugar	58.15	46.18	56.00	45.00	0.00	0.00	0.00	0.00	0.00	0.00	0.00	0.00	0.00	0.00
HEC	1.00	1.00	1.00	1.00	0.00	0.00	0.00	0.00	0.00	0.00	0.00	0.00	0.00	0.00
Bactericide	0.10	0.10	0.10	0.10	0.00	0.00	0.00	0.00	0.00	0.00	0.00	0.00	0.00	0.00
Triton X-100	0.00	0.00	0.00	0.00	0.00	0.00	0.00	0.00	0.00	0.00	0.00	0.00	17.2	10.7
DGBE	0.00	0.00	0.00	0.00	45.33	59.31	44.92	59.10	36.80	26.70	39.10	28.40	0.00	0.00
Dielectric Constant	41.88	54.60	42.54	56.10	40.10	53.60	39.90	54.00	39.80	52.50	39.80	52.50	0.00	0.00
Conductivity (S/m)	0.90	0.97	0.91	0.95	1.39	1.49	1.42	1.45	1.88	1.78	1.88	1.78	0.00	0.00
Diethylene Glycol Mono-hexlether	0.00	0.00	0.00	0.00	0.00	0.00	0.00	0.00	0.00	0.00	0.00	0.00	17.3	10.7

Salt: 99+% Pure Sodium Chloride

Sugar: 98+% Pure Sucrose

Water: De-ionized, 16 M Ω⁺ resistivity

HEC: Hydroxyethyl Cellulose

DGBE: 99+% Di(ethylene glycol) butyl ether, [2-(2-butoxyethoxy)ethanol]

Triton X-100 (ultra pure): Polyethylene glycol mono [4-(1,1,3,3-tetramethylbutyl)phenyl]ether

5.3 Liquid Depth

According to KDB865664 ,the depth of tissue-equivalent liquid in a phantom must be ≥ 15.0 cm with $\leq \pm 0.5$ cm variation for SAR measurements ≤ 3 GHz and ≥ 10.0 cm with $\leq \pm 0.5$ cm variation for measurements > 3 GHz.

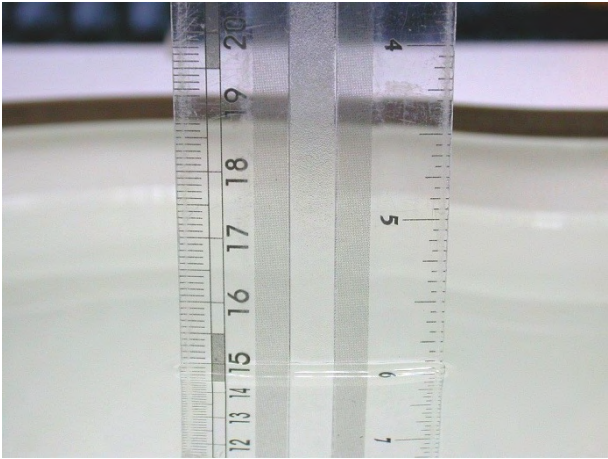
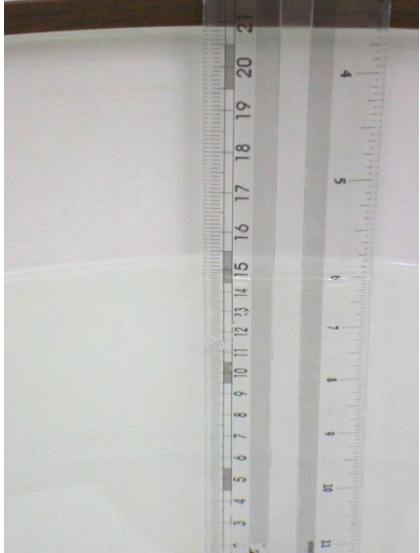
	
Figure 7. Head-Position	Figure 8. Body-Position



6. SAR Testing with RF Transmitters

6.1 SAR Testing with GSM/GPRS/EGPRS Transmitters

Configure the basestation to support GMSK and 8PSK call respectively, and set timeslot transmission for GMSK GSM/GPRS and 8PSK EDGE. Measure and record power outputs for both modulations, that test is applicable.

6.2 SAR Testing with WCDMA Transmitters

The following tests were completed according to the test requirements outlined in section 5.2 of the 3GPP TS34.121-1 specification. The DUT supports power Class 3, which has a nominal maximum output power of 24 dBm (+1.7/-3.7).

- Step 1: set a Test Mode 1 loop back with a 12.2kbps Reference Measurement Channel (RMC).
- Step 2: set and send continuously up power control commands to the device.
- Step 3: measure the power at the device antenna connector using the power meter with average detector and test SAR

6.3 SAR Testing with HSDPA Transmitters

HSDPA Date Devices setup for SAR Measurement

HSDPA should be configured according to the UE category of a test device. The number of HS-DSCH/HS-PDSCHs, HARQ processes, minimum inter-TTI interval, transport block sizes and RV coding sequence are defined by the H-set. To maintain a consistent test configuration and stable transmission conditions, QPSK is used in the H-set for SAR testing. HS-DPCCH should be configured with a CQI feedback cycle of 4 ms with a CQI repetition factor of 2 to maintain a constant rate of active CQI slots. DPCCH and DPDCH gain factors(β_c , β_d), and HS-DPCCH power offset parameters (Δ_{ACK} , Δ_{NACK} , Δ_{CQI}) should be set according to values indicated in the Table below. The CQI value is determined by the UE category, transport block size, number of HS-PDSCHs and modulation used in the H-set.

Setup for Release 5 HSDPA							
Sub-test	β_c	β_d	β_d (SF)	β_c/β_d	$\beta_{hs}^{(1,2)}$	$CM^{(3)}$ (dB)	$MRP^{(3)}$ (dB)
1	2/15	15/15	64	2/15	4/15	0.0	0.0
2	12/15(4)	15/15(4)	64	12/15(4)	24/15	1.0	0.0
3	15/15	8/15	64	15/8	30/15	1.5	0.5
4	15/15	4/15	64	15/4	30/15	1.5	0.5

Note

1. Δ_{ACK} , Δ_{NACK} and $\Delta_{CQI} = 8 \Leftrightarrow A_{hs} = \beta_{hs}/\beta_c = 30/15 \Leftrightarrow \beta_{hs} = 30/15 * \beta_c$
2. For the HS-DPCCH power mask requirement test in clause 5.2C, 5.7A, and the Error Vector Magnitude(EVM) with HS-DPCCH test in clause 5.13.1A and HSDPA EVM with phase discontinuity in clause 5.13.1AA, Δ_{ACK} and $\Delta_{NACK} = 30/15$ with $\beta_{hs} = 30/15 * \beta_c$ and $\Delta_{CQI} = 24/15$ with $\beta_{hs} = 24/15 * \beta_c$
3. $CM = 1$ for $\beta_c/\beta_d = 12/15$, $\beta_{hs}/\beta_c = 24/15$. For all other combinations of DPDCH, DPCCH and HS-DPCCH the MPR is based on the relative CM difference. This is applicable for only UEs that support HSDPA in release 6 and later releases.
4. For subtest 2 the β_c/β_d ratio of 12/15 for the TFC during the measurement period (TF1, TF0) is achieved by setting the signaled gain factors for the reference TFC (TF1, TF1) to $\beta_c = 11/15$ and $\beta_d = 15/15$.



HSPA Data Devices setup for SAR Measurement.

The following procedures are applicable to HSPA (HSUPA/HSDPA) data devices operating under 3GPP Release 6. Body exposure conditions generally apply to these devices, including handsets and data modems operating in various electronic devices. HSUPA operates in conjunction with WCDMA and HSDPA. SAR is initially measured in WCDMA test configurations without HSPA. The default test configuration is to establish a radio link between the DUT and a communication test set to configure a 12.2 kbps RMC (reference measurement channel) in Test Loop Mode 1. SAR for HSPA is selectively measured with HS-DPCCH, EDPCCH and E-DPDCH, all enabled, along with a 12.2 kbps RMC using the highest SAR configuration in WCDMA with 12.2 kbps RMC only. An FRC is configured according to HSDPCCH Sub-test 1 using H-set 1 and QPSK. HSPA is configured according to E-DCH Subtest 5 requirements. SAR for other HSPA sub-test configurations is also confirmed selectively according to output power, exposure conditions and E-DCH UE Category. Maximum output power is verified according to procedures in applicable versions of 3GPP TS 34.121 and SAR must be measured according to these maximum output conditions. The UE Categories for HSDPCCH and HSPA should be clearly identified in the SAR report. The following procedures are applicable only if Maximum Power Reduction (MPR) is implemented according to Cubic Metric (CM) requirements.

When voice transmission and head exposure conditions are applicable to a WCDMA/HSPA data device, head exposure is measured according to the 'Head SAR Measurements' procedures in the 'WCDMA Handsets' section of this document. SAR for body exposure configurations are measured according to the 'Body SAR Measurements' procedures in the 'WCDMA Handsets' section of this document. In addition, body SAR is also measured for HSPA when the maximum average output of each RF channel with HSPA active is at least ¼ dB higher than that measured without HSPA using 12.2 kbps RMC or the maximum SAR for 12.2 kbps RMC is above 75% of the SAR limit. Body SAR for HSPA is measured with E-DCH Sub-test 5, using H-Set 1 and QPSK for FRC and a 12.2 kbps RMC configured in Test Loop Mode 1 with power control algorithm 2, according to the highest body SAR configuration in 12.2 kbps RMC without HSPA. When VOIP is applicable for head exposure, SAR is not required when the maximum output of each RF channel with HSPA is less than ¼ dB higher than that measured using 12.2 kbps RMC; otherwise, the same HSPA configuration used for body measurements should be used to test for head exposure.

Due to inner loop power control requirements in HSPA, a commercial communication test set should be used for the output power and SAR tests. The 12.2 kbps RMC, FRC H-set 1 and E-DCH configurations for HSPA should be configured according to the β values indicated below as well as other applicable procedures described in the 'WCDMA Handset' and 'Release 5 HSDPA Data Devices' sections of this document.



The highest body SAR measured in Antenna Extended & Retracted configurations on a channel in 12.2 kbps RMC. The possible channels are the High, Middle & Low channel. Contact the FCC Laboratory for test and approval requirements if the maximum output power measured in E-DCH Sub-test 2 - 4 is higher than Sub-test 5.

Setup for Release 6 HSPA / Release 7 HSPA+													
Sub-test	β_c	β_d	β_d (SF)	β_c/β_d	$\beta_{hs}^{(1)}$	β_{ec}	β_{ed}	Bed (SF)	Bed (codes)	CM ⁽²⁾ (dB)	MPR (dB)	AG ⁽⁴⁾ Index	E-TFCI
1	11/15 ⁽³⁾	15/15 ⁽³⁾	64	11/15 ⁽³⁾	22/15	209/225	1039/225	4	1	1.0	0.0	20	75
2	6/15	15/15	64	6/15	12/15	12/15	94/75	4	1	3.0	2.0	12	67
3	15/15	9/15	64	15/9	30/15	30/15	β_{ed1} : 47/15 β_{ed2} : 47/15	4	2	2.0	1.0	15	92
4	2/15	15/15	64	2/15	4/15	2/15	56/75	4	1	3.0	2.0	17	71
5	15/15 ⁽⁴⁾	15/15 ⁽⁴⁾	64	15/15 ⁽⁴⁾	30/15	24/15	134/15	4	1	1.0	0.0	21	81

Note

1. Δ_{ACK} , Δ_{NACK} and $\Delta_{CQI} = 8 \Leftrightarrow A_{hs} = \beta_{hs}/\beta_c = 30/15 \Leftrightarrow \beta_{hs} = 30/15 * \beta_c$.
2. CM = 1 for $\beta_c/\beta_d = 12/15$, $\beta_{hs}/\beta_c = 24/15$. For all other combinations of DPDCH, DPCCH, HS-DPCCH, E-DPDCH and E-DPCCH the MPR is based on the relative CM difference.
3. For subtest 1 the β_c/β_d ratio of 11/15 for the TFC during the measurement period (TF1, TF0) is achieved by setting the signaled gain factors for the reference TFC (TF1, TF1) to $\beta_c = 10/15$ and $\beta_d = 15/15$.
4. For subtest 5 the β_c/β_d ratio of 15/15 for the TFC during the measurement period (TF1, TF0) is achieved by setting the signaled gain factors for the reference TFC (TF1, TF1) to $\beta_c = 14/15$ and $\beta_d = 15/15$.
5. Testing UE using E-DPDCH Physical Layer category 1 Sub-test 3 is not required according to TS 25.306 Table 5.1g.
6. β_{ed} can not be set directly; it is set by Absolute Grant Value.



6.4 SAR Testing with 802.11 Transmitters

SAR test reduction for 802.11 Wi-Fi transmission mode configurations are considered separately for DSSS and OFDM. An initial test position is determined to reduce the number of tests required for certain exposure configurations with multiple test positions. An initial test configuration is determined for each frequency band and aggregated band according to maximum output power, channel bandwidth, wireless mode configurations and other operating parameters to streamline the measurement requirements. For 2.4 GHz DSSS, either the initial test position or DSSS procedure is applied to reduce the number of SAR tests; these are mutually exclusive. For OFDM, an initial test position is only applicable to next to the ear, UMPC mini-tablet and hotspot mode configurations, which is tested using the initial test configuration to facilitate test reduction. For other exposure conditions with a fixed test position, SAR test reduction is determined using only the initial test configuration.

The multiple test positions require SAR measurements in head, hotspot mode or UMPC mini-tablet configurations may be reduced according to the highest reported SAR determined using the initial test position(s) by applying the DSSS or OFDM SAR measurement procedures in the required wireless mode test configuration(s). The initial test position(s) is measured using the highest measured maximum output power channel in the required wireless mode test configuration(s). When the reported SAR for the initial test position is:

- ≤ 0.4 W/kg, further SAR measurement is not required for the other test positions in that exposure configuration and wireless mode combination within the frequency band or aggregated band. DSSS and OFDM configurations are considered separately according to the required SAR procedures.
- > 0.4 W/kg, SAR is repeated using the same wireless mode test configuration tested in the initial test position to measure the subsequent next closest/smallest test separation distance and maximum coupling test position, on the highest maximum output power channel, until the reported SAR is ≤ 0.8 W/kg or all required test positions are tested.
 - For subsequent test positions with equivalent test separation distance or when exposure is dominated by coupling conditions, the position for maximum coupling condition should be tested.
 - When it is unclear, all equivalent conditions must be tested.
- For all positions/configurations tested using the initial test position and subsequent test positions, when the reported SAR is > 0.8 W/kg, measure the SAR for these positions/configurations on the subsequent next highest measured output power channel(s) until the reported SAR is ≤ 1.2 W/kg or all required test channels are considered.
 - The additional power measurements required for this step should be limited to those necessary for identifying subsequent highest output power channels to apply the test reduction.
- When the specified maximum output power is the same for both UNII 1 and UNII 2A, begin SAR measurements in UNII 2A with the channel with the highest measured output power. If the reported SAR for UNII 2A is ≤ 1.2 W/kg, SAR is not required for UNII 1; otherwise treat the remaining bands separately and test them independently for SAR.
- When the specified maximum output power is different between UNII 1 and UNII 2A, begin SAR with the band that has the higher specified maximum output. If the highest reported SAR for the band with the highest specified power is ≤ 1.2 W/kg, testing for the band with the lower specified output power is not required; otherwise test the remaining bands independently for SAR.

To determine the initial test position, Area Scans were performed to determine the position with the Maximum Value of SAR (measured). The position that produced the highest Maximum Value of SAR is considered the worst case position; thus used as the initial test position.



6.5 Conducted Power

Band	Modulation	Data Rate	CH	Frequency (MHz)	Average Power (dBm)	
					Time Average	Burst Average
GSM 850	GMSK	1Down1Up Duty factor 1/8	Lowest	824.2	23.95	32.98
			Middle	836.6	23.98	33.01
			Highest	848.8	24.06	33.09
GPRS 850 Multi Class :12 Max Up:4 Max Down:4 Sum:5	GMSK	4Down1Up Duty factor 1/8	Lowest	824.2	23.83	32.86
			Middle	836.6	23.87	32.90
			Highest	848.8	23.94	32.97
		3Down2Up Duty factor 2/8	Lowest	824.2	26.59	32.61
			Middle	836.6	26.63	32.65
			Highest	848.8	26.69	32.71
		2Down3Up Duty factor 3/8	Lowest	824.2	27.93	32.19
			Middle	836.6	27.97	32.23
			Highest	848.8	28.05	32.31
		1Down4Up Duty factor 4/8	Lowest	824.2	28.23	31.24
			Middle	836.6	28.25	31.26
			Highest	848.8	28.32	31.33
EGPRS 850 Multi Class :12 Max Up:4 Max Down:4 Sum:5	8PSK	4Down1Up Duty factor 1/8	Lowest	824.2	18.63	27.66
			Middle	836.6	18.71	27.74
			Highest	848.8	18.75	27.78
		3Down2Up Duty factor 2/8	Lowest	824.2	21.50	27.52
			Middle	836.6	21.61	27.63
			Highest	848.8	21.64	27.66
		2Down3Up Duty factor 3/8	Lowest	824.2	23.11	27.37
			Middle	836.6	23.18	27.44
			Highest	848.8	23.27	27.53
		1Down4Up Duty factor 4/8	Lowest	824.2	24.20	27.21
			Middle	836.6	24.32	27.33
			Highest	848.8	24.40	27.41

Note: 1. Time Average power slot duty cycle factor calculate:

1up: Average burst power+10*LOG(1/8)

2up: Average burst power+10*LOG(2/8)

3up: Average burst power+10*LOG(3/8)

4up: Average burst power+10*LOG(4/8)



Band	Modulation	Data Rate	CH	Frequency (MHz)	Average Power (dBm)	
					Time Average	Burst Average
GSM 1900	GMSK	1Down1Up Duty factor 1/8	Lowest	1850.2	21.35	30.38
			Middle	1880.0	21.39	30.42
			Highest	1909.8	21.46	30.49
GPRS 1900 Multi Class :12 Max Up:4 Max Down:4 Sum:5	GMSK	4Down1Up Duty factor 1/8	Lowest	1850.2	21.18	30.21
			Middle	1880.0	21.25	30.28
			Highest	1909.8	21.31	30.34
		3Down2Up Duty factor 2/8	Lowest	1850.2	24.05	30.07
			Middle	1880.0	24.10	30.12
			Highest	1909.8	24.17	30.19
		2Down3Up Duty factor 3/8	Lowest	1850.2	24.86	29.12
			Middle	1880.0	24.97	29.23
			Highest	1909.8	25.03	29.29
		1Down4Up Duty factor 4/8	Lowest	1850.2	24.95	27.96
			Middle	1880.0	25.05	28.06
			Highest	1909.8	25.14	28.15
EGPRS 1900 Multi Class :12 Max Up:4 Max Down:4 Sum:5	8PSK	4Down1Up Duty factor 1/8	Lowest	1850.2	17.48	26.51
			Middle	1880.0	17.63	26.66
			Highest	1909.8	17.78	26.81
		3Down2Up Duty factor 2/8	Lowest	1850.2	20.34	26.36
			Middle	1880.0	20.50	26.52
			Highest	1909.8	20.67	26.69
		2Down3Up Duty factor 3/8	Lowest	1850.2	21.98	26.24
			Middle	1880.0	22.15	26.41
			Highest	1909.8	22.30	26.56
		1Down4Up Duty factor 4/8	Lowest	1850.2	23.08	26.09
			Middle	1880.0	23.21	26.22
			Highest	1909.8	23.43	26.44

Note: 1. Time Average power slot duty cycle factor calculate:

1up: Average burst power+10*LOG(1/8)

2up: Average burst power+10*LOG(2/8)

3up: Average burst power+10*LOG(3/8)

4up: Average burst power+10*LOG(4/8)



Band	Modulation	Sub-test	CH	Frequency (MHz)	Burst Average Power (dBm)
WCDMA Band II (RMC12.2K)	QPSK	---	Lowest	1852.4	23.56
			Middle	1880.0	23.64
			Highest	1907.6	23.27
HSDPA Band II	QPSK	1	Lowest	1852.4	22.55
			Middle	1880.0	22.64
			Highest	1907.6	22.22
		2	Lowest	1852.4	22.44
			Middle	1880.0	22.52
			Highest	1907.6	22.08
		3	Lowest	1852.4	22.01
			Middle	1880.0	22.12
			Highest	1907.6	21.66
		4	Lowest	1852.4	21.98
			Middle	1880.0	22.07
			Highest	1907.6	21.62
HSUPA Band II	QPSK	1	Lowest	1852.4	21.92
			Middle	1880.0	22.01
			Highest	1907.6	21.59
		2	Lowest	1852.4	19.92
			Middle	1880.0	20.00
			Highest	1907.6	19.56
		3	Lowest	1852.4	20.86
			Middle	1880.0	20.99
			Highest	1907.6	20.54
		4	Lowest	1852.4	19.88
			Middle	1880.0	19.96
			Highest	1907.6	19.54
		5	Lowest	1852.4	21.82
			Middle	1880.0	21.88
			Highest	1907.6	21.45



Band	Modulation	Sub-test	CH	Frequency (MHz)	Burst Average Power (dBm)
WCDMA Band V (RMC12.2K)	QPSK	---	Lowest	826.4	23.46
			Middle	836.6	23.64
			Highest	846.6	23.42
HSDPA Band V	QPSK	1	Lowest	826.4	22.45
			Middle	836.6	22.62
			Highest	846.6	22.39
		2	Lowest	826.4	22.36
			Middle	836.6	22.55
			Highest	846.6	22.29
		3	Lowest	826.4	21.94
			Middle	836.6	22.12
			Highest	846.6	21.84
		4	Lowest	826.4	21.91
			Middle	836.6	22.05
			Highest	846.6	21.81
HSUPA Band V	QPSK	1	Lowest	826.4	21.77
			Middle	836.6	21.95
			Highest	846.6	21.71
		2	Lowest	826.4	19.77
			Middle	836.6	19.93
			Highest	846.6	19.68
		3	Lowest	826.4	20.71
			Middle	836.6	20.87
			Highest	846.6	20.62
		4	Lowest	826.4	19.71
			Middle	836.6	19.87
			Highest	846.6	19.62
		5	Lowest	826.4	21.66
			Middle	836.6	21.81
			Highest	846.6	21.55



Band	Data Rate (Mbps)	CH	Frequency (MHz)	Average Power (dBm)
IEEE 802.11b	1	1	2412	7.33
		6	2437	7.24
		11	2462	7.28
	2	6	2437	7.13
	5.5	6	2437	7.13
	11	6	2437	7.13
IEEE 802.11g	6	1	2412	8.32
		6	2437	8.48
		11	2462	8.46
	9	6	2437	8.33
	12	6	2437	8.36
	18	6	2437	8.43
	24	6	2437	8.37
	36	6	2437	8.45
	48	6	2437	8.32
	54	6	2437	8.38
IEEE 802.11n 2.4 GHz 20MHz	6.5	1	2412	8.35
		6	2437	8.47
		11	2462	8.42
	13	6	2437	8.43
	19.5	6	2437	8.32
	26	6	2437	8.44
	39	6	2437	8.42
	52	6	2437	8.36
	58.5	6	2437	8.30
	65	6	2437	8.37

6.6 Antenna location

Antenna-User		
Side	WWAN_ANT	WLAN_ANT
Side 1	7	8
Side 2	14	14
Side 3	4	57
Side 4	75	23
Side 5	7	45
Side 6	6	12

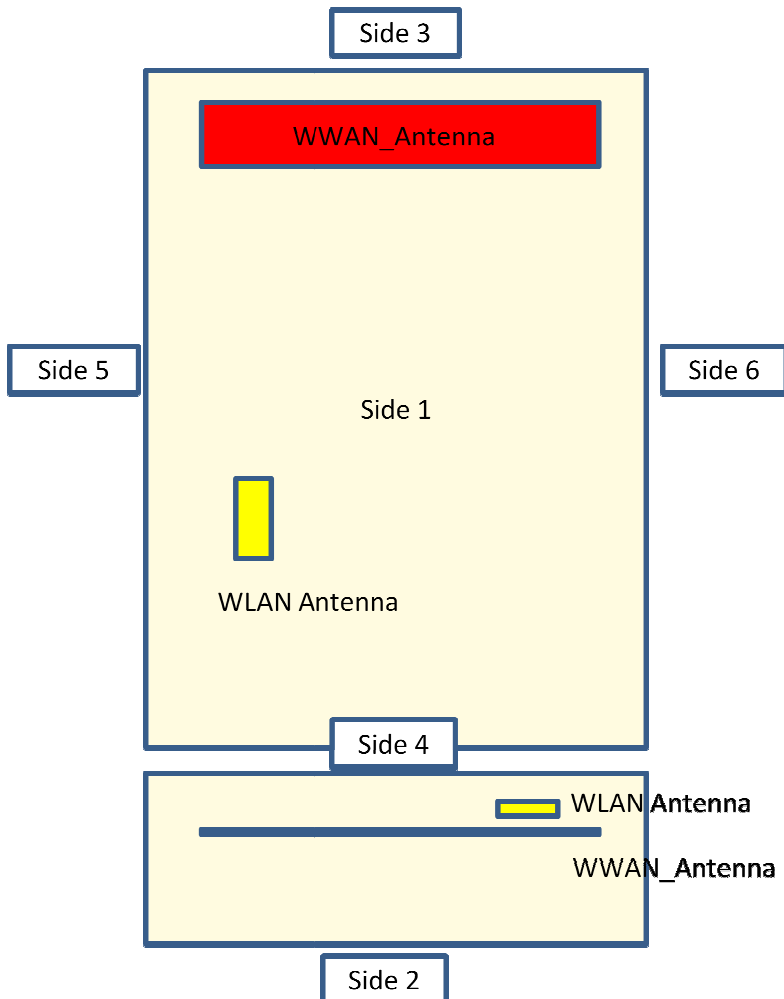



6.7 Stand-alone SAR Evaluate

Stand-alone transmission configurations as below:

Band	Side 1	Side 2	Side 3	Side 4	Side 5	Side 6
GSM/GPRS/EGPRS 850	V	V	V	-	V	V
GSM/GPRS/EGPRS 1900	V	V	V	-	V	V
WCDMA/HSDPA/HSUPA/HSPA+ Band II	V	V	V	-	V	V
WCDMA/HSDPA/HSUPA/HSPA+ Band V	V	V	V	-	V	V
IEEE 802.11b	-	-	-	-	-	-
IEEE 802.11g	-	-	-	-	-	-
IEEE 802.11n 2.4GHz 20MHz	-	-	-	-	-	-

- Note: 1. The "-" on behalf of Stand-alone SAR is not required (Refer to KDB447498 D01 v06 4.3.1 for the Standalone SAR test exclusion)
2. Stand-alone SAR is required when SAR must be measured for all sides and surfaces with a transmitting antenna located within 25 mm from that surface or edge, detail refer antenna location.

Antenna	Operate Band	Channel	Frequency (GHz)	Tune-Power		Evaluate Distance of Ant.To User (mm)					
				(dBm)	(mW)	Side 1	Side 2	Side 3	Side 4	Side 5	Side 6
WWAN ANT	GSM 850	251	0.8488	33.5	2239	7	14	5	75	7	6
	GPRS 850	251	0.8488	33.5	2239	7	14	5	75	7	6
	GSM 1900	810	1.9098	31	1259	7	14	5	75	7	6
	GPRS 1900	810	1.9098	31	1259	7	14	5	75	7	6
	WCDMA Band II	9538	1.9076	24	251	7	14	5	75	7	6
	WCDMA Band V	4233	0.8466	24	251	7	14	5	75	7	6
WLAN ANT	IEEE 802.11 b	11	2.462	8	6	8	14	57	23	45	12
	IEEE 802.11 g	11	2.462	8.5	7	8	14	57	23	45	12
	IEEE 802.11 n 2.4GHz 20MHz	11	2.462	8.5	7	8	14	57	23	45	12



Antenna	Operate Band	Channel	Frequency (GHz)	Tune-Power		Calculated value and evaluated result (mm)					
				(dBm)	(mW)	Side 1	Side 2	Side 3	Side 4	Side 5	Side 6
WWAN ANT	GSM 850	251	0.8488	33.5	2239	294.7	147.3	412.6	---	294.7	343.8
						MEASURE	MEASURE	MEASURE	---	MEASURE	MEASURE
	GPRS 850	251	0.8488	33.5	2239	294.7	147.3	412.6	---	294.7	343.8
						MEASURE	MEASURE	MEASURE	---	MEASURE	MEASURE
	GSM 1900	810	1.9098	31	1259	248.6	124.3	348	---	248.6	290
						MEASURE	MEASURE	MEASURE	---	MEASURE	MEASURE
	GPRS 1900	810	1.9098	31	1259	248.6	124.3	348	---	248.6	290
						MEASURE	MEASURE	MEASURE	---	MEASURE	MEASURE
WCDMA Band II	9538	1.9076	24	251	49.5	24.8	69.3	---	49.5	57.8	
					MEASURE	MEASURE	MEASURE	---	MEASURE	MEASURE	
WCDMA Band V	4233	0.8466	24	251	33	16.5	46.2	---	33	38.5	
					MEASURE	MEASURE	MEASURE	---	MEASURE	MEASURE	
WLAN	IEEE 802.11 b	11	2.462	8	6	1.2	0.7	---	0.4	0.2	0.8
						EXEMPT	EXEMPT	---	EXEMPT	EXEMPT	EXEMPT
	IEEE 802.11 g	11	2.462	8.5	7	1.4	0.8	---	0.5	0.2	0.9
						EXEMPT	EXEMPT	---	EXEMPT	EXEMPT	EXEMPT
	IEEE 802.11 n 2.4GHz 20MHz	11	2.462	8.5	7	1.4	0.8	---	0.5	0.2	0.9
						EXEMPT	EXEMPT	---	EXEMPT	EXEMPT	EXEMPT

- Note: 1. Calculated Value include string "mW", that is mean through compare output power with threshold, if the output power more than threshold value the SAR test should be perform. Otherwise, the SAR test could be exempt. (> 50mm).
2. Calculated Value only include number format, that is mean through compare output power with threshold, if the Calculated value more than 3, the SAR test should be perform. Otherwise, the SAR test could be exempt. (<50mm).
3. When an antenna qualifies for the standalone SAR test exclusion of KDB 447498 section 4.3.1 and also transmits simultaneously with other antennas, the standalone SAR value must be estimated according to KDB 447498 section "4.3.2. Simultaneous transmission SAR tests exclusion considerations b) ".
4. The channel and frequency used highest frequency and power, which result should be evaluated the worst case.
5. Power and distance are rounded to the nearest mW and mm before calculation.
6. The result is rounded to one decimal place for comparison.
7. We used antenna located within 25 mm from that surface or edge to show calculated value and evaluated result.

6.8 Simultaneous Transmitting Evaluate

This device does not support simultaneous transmitting.

6.9 SAR test reduction according to KDB

General:

- The test data reported are the worst-case SAR value with the position set in a typical configuration. Test procedures used were according to FCC, Supplement C [June 2001], IEEE1528-2013.
- All modes of operation were investigated, and worst-case results are reported.
- Tissue parameters and temperatures are listed on the SAR plots.
- Batteries are fully charged for all readings.
- When the Channel's SAR 1g of maximum conducted power is > 0.8 mW/g, low, middle and high channel are supposed to be tested.

KDB 447498:

- The test data reported are the worst-case SAR value with the position set in a typical configuration. Test procedures used were according to IEEE1528-2013.

KDB 865664:

- Repeated measurement is not required when the original highest measured SAR is < 0.80 W/kg.
- When the original highest measured SAR is ≥ 0.80 W/kg, repeat that measurement once.
- Perform a second repeated measurement only if the ratio of largest to smallest SAR for the original and first repeated measurements is > 1.20 or when the original or repeated measurement is ≥ 1.45 W/kg.
- Perform a third repeated measurement only if the original, first or second repeated measurement is ≥ 1.5 W/kg and the ratio of largest to smallest SAR for the original, first and second repeated measurements is > 1.20 .

KDB 941225:

- In order to qualify for the above test reduction, the maximum burst-averaged output power for each mode (GMS/GPRS/EDGE) and the corresponding multi-slot class must be clearly identified in the SAR report for each frequency band. We perform worst case SAR with maximum time-average power on GMS/GPRS/EDGE mode.
- When HSDPA & (HSUPA / HSPA+ uplink with QPSK) power are not more than WCDMA 12.2K RMC 0.25dB and the SAR value of WCDMA BII/BV < 1.2 mW/g, therefore HSDPA & HSUPA / HSPA+ Stand-alone SAR is not required.

KDB 248227:

- Refer 6.4 SAR Testing with 802.11 Transmitters.

7. System Verification and Validation

7.1 Symmetric Dipoles for System Verification

Construction	Symmetrical dipole with 1/4 balun enables measurement of feed point impedance with NWA matched for use near flat phantoms filled with head simulating solutions Includes distance holder and tripod adaptor Calibration Calibrated SAR value for specified position and input power at the flat phantom in head simulating solutions.
Frequency	835, 1900 MHz
Return Loss	> 20 dB at specified verification position
Power Capability	> 100 W (f < 1GHz); > 40 W (f > 1GHz)
Options	Dipoles for other frequencies or solutions and other calibration conditions are available upon request
Dimensions	D835V2: dipole length 161 mm; overall height 340 mm D1900V2: dipole length 67.7 mm; overall height 300 mm

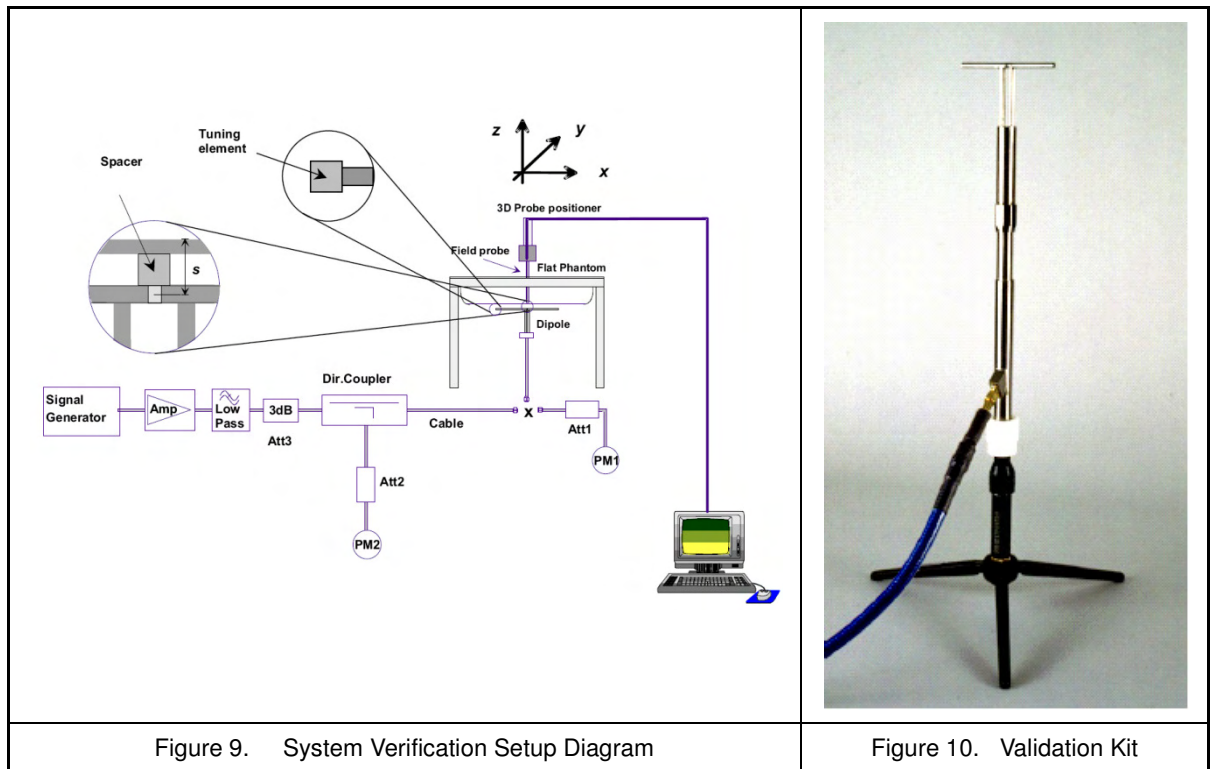

Figure 9. System Verification Setup Diagram

Figure 10. Validation Kit



7.2 Liquid Parameters

Liquid Verify								
Ambient Temperature : 22 ± 2 °C ; Relative Humidity : 40 -70%								
Liquid Type	Frequency	Temp (°C)	Parameters	Target Value	Measured Value	Deviation (%)	Limit (%)	Measured Date
835MHz (Head)	820MHz	22.0	ϵ_r	41.57	42.15	1.44	± 5	Nov. 23, 2016
			σ	0.898	0.895	-1.11	± 5	
	835MHz	22.0	ϵ_r	41.50	41.94	0.96	± 5	
			σ	0.900	0.915	1.11	± 5	
	850MHz	22.0	ϵ_r	41.50	41.83	0.72	± 5	
			σ	0.916	0.935	2.17	± 5	
835MHz (Body)	820MHz	22.0	ϵ_r	55.26	54.45	-1.63	± 5	Nov. 23, 2016
			σ	0.969	0.949	-2.06	± 5	
	835MHz	22.0	ϵ_r	55.20	54.33	-1.63	± 5	
			σ	0.970	0.968	0.00	± 5	
	850MHz	22.0	ϵ_r	55.15	54.44	-1.45	± 5	
			σ	0.988	0.995	1.01	± 5	
835MHz (Body)	820MHz	22.0	ϵ_r	55.26	54.45	-1.63	± 5	Dec. 05, 2016
			σ	0.969	0.949	-2.06	± 5	
	835MHz	22.0	ϵ_r	55.20	54.33	-1.63	± 5	
			σ	0.970	0.968	0.00	± 5	
	850MHz	22.0	ϵ_r	55.15	54.44	-1.45	± 5	
			σ	0.988	0.995	1.01	± 5	

Table 3. Measured Tissue dielectric parameters for body phantoms -1



Liquid Verify								
Ambient Temperature : 22 ± 2 °C ; Relative Humidity : 40 -70%								
Liquid Type	Frequency	Temp (°C)	Parameters	Target Value	Measured Value	Deviation (%)	Limit (%)	Measured Date
1900MHz (Head)	1850MHz	22.0	ϵ_r	40.00	40.82	2.00	± 5	Nov. 23, 2016
			σ	1.400	1.344	-4.29	± 5	
	1900MHz	22.0	ϵ_r	40.00	40.70	1.75	± 5	
			σ	1.400	1.392	-0.71	± 5	
	1950MHz	22.0	ϵ_r	40.00	40.59	1.50	± 5	
			σ	1.400	1.439	2.86	± 5	
1900MHz (Body)	1850MHz	22.0	ϵ_r	53.30	52.19	-2.06	± 5	Nov. 23, 2016
			σ	1.520	1.527	0.66	± 5	
	1900MHz	22.0	ϵ_r	53.30	52.15	-2.25	± 5	
			σ	1.520	1.583	3.95	± 5	
	1950MHz	22.0	ϵ_r	53.30	51.62	-3.19	± 5	
			σ	1.520	1.594	4.61	± 5	
1900MHz (Body)	1850MHz	22.0	ϵ_r	53.30	52.19	-2.06	± 5	Dec. 05, 2016
			σ	1.520	1.527	0.66	± 5	
	1900MHz	22.0	ϵ_r	53.30	52.15	-2.25	± 5	
			σ	1.520	1.583	3.95	± 5	
	1950MHz	22.0	ϵ_r	53.30	51.62	-3.19	± 5	
			σ	1.520	1.594	4.61	± 5	

Table 4. Measured Tissue dielectric parameters for body phantoms -2



7.3 Verification Summary

Prior to the assessment, the system validation kit was used to test whether the system was operating within its specifications of $\pm 7\%$. The verification was performed at 835 MHz and 1900 MHz.

Mixture Type	Frequency (MHz)	Power	SAR _{1g} (W/Kg)	SAR _{10g} (W/Kg)	Drift (dB)	Difference percentage		Probe Model / Serial No.	Dipole Model / Serial No.	1W Target		Date
						1g	10g			SAR _{1g} (mW/g)	SAR _{10g} (mW/g)	
Head	835	250 mW	2.38	1.55	-0.02	1.00%	0.20%	EX3DV4 SN:3977	D835V2 SN:4d082	9.43	6.19	Nov. 23, 2016
		Normalize to 1 Watt	9.52	6.20								
Body	835	250 mW	2.37	1.56	0.01	-1.80%	-3.10%	EX3DV4 SN:3977	D835V2 SN:4d082	9.65	6.44	Nov. 23, 2016
		Normalize to 1 Watt	9.48	6.24								
Body	835	250 mW	2.35	1.54	-0.08	-2.60%	-4.30%	EX3DV4 SN:3977	D835V2 SN:4d082	9.65	6.44	Dec. 05, 2016
		Normalize to 1 Watt	9.40	6.16								
Head	1900	250 mW	10.3	5.3	-0.03	2.50%	1.00%	EX3DV4 SN:3977	D1900V2 SN:5d111	40.20	21.00	Nov. 23, 2016
		Normalize to 1 Watt	41.20	21.20								
Body	1900	250 mW	9.93	5.11	-0.05	-1.40%	-4.50%	EX3DV4 SN:3977	D1900V2 SN:5d111	40.30	21.40	Nov. 23, 2016
		Normalize to 1 Watt	39.72	20.44								
Body	1900	250 mW	10.1	5.21	0.07	0.20%	-2.60%	EX3DV4 SN:3977	D1900V2 SN:5d111	40.30	21.40	Dec. 05, 2016
		Normalize to 1 Watt	40.40	20.84								



7.4 Validation Summary

Per FCC KDB 865664 D02 v01r02, SAR system validation status should be documented to confirm measurement accuracy. The SAR systems (including SAR probes, system components and software versions) used for this device were validated against its performance specifications prior to the SAR measurements. Reference dipoles were used with the required tissue- equivalent media for system validation, according to the procedures outlined in IEEE 1528-2013 and FCC KDB 865664 D01v01r04. Since SAR probe calibrations are frequency dependent, each probe calibration point was validated at a frequency within the valid frequency range of the probe calibration point, using the system that normally operates with the probe for routine SAR measurements and according to the required tissue-equivalent media.

A tabulated summary of the system validation status including the validation date(s), measurement frequencies, SAR probes and tissue dielectric parameters as below.

Probe Type Model / Serial No.	Prob Cal. Point (MHz)	Head / Body	Cond.	Perm.	CW Validation			Mod. Validation			Date
			ϵ_r	σ	Sensitivity	Probe	Probe	Mod. Type	Duty Factor	PAR	
						Linearity	Isotropy				
EX3DV4 SN:3977	835	Head	41.94	0.915	Pass	Pass	Pass	GMSK, RMC.12.2K	Pass	N/A	Nov. 23, 2016
EX3DV4 SN:3977	835	Body	54.33	0.968	Pass	Pass	Pass	GMSK, RMC.12.2K	Pass	N/A	Nov. 23, 2016
EX3DV4 SN:3977	835	Body	54.33	0.968	Pass	Pass	Pass	GMSK, RMC.12.2K	Pass	N/A	Dec. 05, 2016
EX3DV4 SN:3977	1900	Head	40.70	1.392	Pass	Pass	Pass	GMSK, RMC.12.2K	Pass	N/A	Nov. 23, 2016
EX3DV4 SN:3977	1900	Body	52.15	1.583	Pass	Pass	Pass	GMSK, RMC.12.2K	Pass	N/A	Nov. 23, 2016
EX3DV4 SN:3977	1900	Body	52.15	1.583	Pass	Pass	Pass	GMSK, RMC.12.2K	Pass	N/A	Dec. 05, 2016



8. Test Equipment List

Manufacturer	Name of Equipment	Type/Model	Serial Number	Calibration	
				Last Cal.	Due Date
SPEAG	835MHz System Validation Kit	D835V2	4d082	Aug. 23, 2016	Aug. 23, 2017
SPEAG	1900MHz System Validation Kit	D1900V2	5d111	Jun. 23, 2016	Jun. 23, 2017
SPEAG	Dosimetric E-Field Probe	EX3DV4	3977	Mar. 09, 2016	Mar. 09, 2017
SPEAG	Data Acquisition Electronics	DAE4	779	Mar. 02, 2016	Mar. 02, 2017
SPEAG	Device Holder	N/A	N/A	NCR	
SPEAG	Measurement Server	SE UMS 011 AA	1025	NCR	
SPEAG	Phantom	SAM V4.0	TP-1150	NCR	
SPEAG	Phantom (ELI V4.0)	QDOVA001BB	TP-1036	NCR	
SPEAG	Robot	Staubli TX90XL	F07/564ZA1/C/01	NCR	
SPEAG	Software	DASY52 V52.8 (8)	N/A	NCR	
SPEAG	Software	SEMCAD X V14.6.10 (7331)	N/A	NCR	
Agilent	Dielectric Probe Kit	85070C	US99360094	NCR	
Agilent	ENA Series Network Analyzer	E5071B	MY42404655	Apr. 13, 2016	Apr. 13, 2017
R&S	Power Sensor	NRP-Z22	100179	NCR	
Agilent	Power Sensor	8481H	3318A20779	Jun. 06, 2016	Jun. 06, 2017
Agilent	Power Meter	EDM Series E4418B	GB40206143	Jun. 06, 2016	Jun. 06, 2017
Anritsu	Power Meter	ML2495A	1135009	Aug. 24, 2016	Aug. 24, 2017
Agilent	MXF-G-B RF Vector Signal Generator	N5182B	MY53050382	May 20, 2016	May 20, 2017
R & S	Wireless Communication Test Set	CMU200	109369	Oct. 28, 2016	Oct. 28, 2018
Agilent	Wireless Communication Test Set	E5515C(8960)	GB47020167	Jun. 02, 2016	Jun. 02, 2018
Agilent	Dual Directional Coupler	778D	50334	NCR	
Mini-Circuits	Power Amplifier	ZHL-42W-SMA	D111103#5	NCR	
Mini-Circuits	Power Amplifier	ZVE-8G-SMA	D042005 671800514	NCR	
Aisi	Attenuator	IEAT 3dB	N/A	NCR	

Table 5. Test Equipment List



9. **Measurement Uncertainty**

Measurement uncertainties in SAR measurements are difficult to quantify due to several variables including biological, physiological, and environmental. However, we estimate the measurement uncertainties in SAR_{1g} to be less than $\pm 21.76\%$ for 300MHz ~3GHz and 3GHz ~ 6GHz $\pm 25.68\%$ [8] .

According to Std. C95.3 [9], the overall uncertainties are difficult to assess and will vary with the type of meter and usage situation. However, accuracy's of ± 1 to 3 dB can be expected in practice, with greater uncertainties in near-field situations and at higher frequencies (shorter wavelengths), or areas where large reflecting objects are present. Under optimum measurement conditions, SAR measurement uncertainties of at least ± 2 dB can be expected.



Uncertainty of a Measure SAR of EUT with DASY System

Item	Uncertainty Component	Uncertainty Value	Prob. Dist	Div.	c_i (1g)	c_i (10g)	Std. Unc. (1-g)	Std. Unc. (10-g)	V_i or V_{eff}
Measurement System									
u1	Probe Calibration ($k=1$)	±6.0%	Normal	1	1	1	±6.0%	±6.0%	∞
u2	Axial Isotropy	±4.7%	Rectangular	$\sqrt{3}$	0.7	0.7	±1.9%	±1.9%	∞
u3	Hemispherical Isotropy	±9.6%	Rectangular	$\sqrt{3}$	0.7	0.7	±3.9%	±3.9%	
u4	Boundary Effect	±1.0%	Rectangular	$\sqrt{3}$	1	1	±0.6%	±0.6%	∞
u5	Linearity	±4.7%	Rectangular	$\sqrt{3}$	1	1	±2.7%	±2.7%	∞
u6	System Detection Limit	±1.0%	Rectangular	$\sqrt{3}$	1	1	±0.6%	±0.6%	∞
u7	Readout Electronics	±0.3%	Normal	1	1	1	±0.3%	±0.3%	∞
u8	Response Time	±0.8%	Rectangular	$\sqrt{3}$	1	1	±0.5%	±0.5%	∞
u9	Integration Time	±1.9%	Rectangular	$\sqrt{3}$	1	1	±1.1%	±1.1%	∞
u10	RF Ambient Conditions	±3.0%	Rectangular	$\sqrt{3}$	1	1	±1.7%	±1.7%	∞
u11	RF Ambient Reflections	±3.0%	Rectangular	$\sqrt{3}$	1	1	±1.7%	±1.7%	∞
u12	Probe Positioner Mechanical Tolerance	±0.4%	Rectangular	$\sqrt{3}$	1	1	±0.2%	±0.2%	∞
u13	Probe Positioning with respect to Phantom Shell	±2.9%	Rectangular	$\sqrt{3}$	1	1	±1.7%	±1.7%	∞
u14	Extrapolation, interpolation and integration Algorithms for Max. SAR Evaluation	±1.0%	Rectangular	$\sqrt{3}$	1	1	±0.6%	±0.6%	∞
Test sample Related									
u15	Test sample Positioning	±3.6%	Normal	1	1	1	±3.6%	±3.6%	89
u16	Device Holder Uncertainty	±2.7%	Normal	1	1	1	±2.7%	±2.7%	5
u17	Output Power Variation - SAR drift measurement	±5.0%	Rectangular	$\sqrt{3}$	1	1	±2.9%	±2.9%	∞
Phantom and Tissue Parameters									
u18	Phantom Uncertainty (shape and thickness tolerances)	±4.0%	Rectangular	$\sqrt{3}$	1	1	±2.3%	±2.3%	∞
u19	Liquid Conductivity - deviation from target values	±5.0%	Rectangular	$\sqrt{3}$	0.64	0.43	±1.8%	±1.2%	∞
u20	Liquid Conductivity - measurement uncertainty	±2.5%	Normal	1	0.64	0.43	±1.6%	±1.08%	69
u21	Liquid Permittivity - deviation from target values	±5.0%	Rectangular	$\sqrt{3}$	0.6	0.49	±1.7%	±1.4%	∞
u22	Liquid Permittivity - measurement uncertainty	±2.5%	Normal	1	0.6	0.49	±1.5%	±1.23%	69
Combined standard uncertainty			RSS				±10.88%	±10.66%	313
Expanded uncertainty (95% CONFIDENCE LEVEL)			$k=2$				±21.76%	±21.31%	

Table 6. Uncertainty Budget for frequency range 300MHz to 3GHz



Uncertainty of a Measure SAR of EUT with DASY System

Item	Uncertainty Component	Uncertainty Value	Prob. Dist	Div.	c_i (1g)	c_i (10g)	Std. Unc. (1-g)	Std. Unc. (10-g)	V_i or V_{eff}
Measurement System									
u1	Probe Calibration ($k=1$)	±6.5%	Normal	1	1	1	±6.5%	±6.5%	∞
u2	Axial Isotropy	±4.7%	Rectangular	$\sqrt{3}$	0.7	0.7	±1.9%	±1.9%	∞
u3	Hemispherical Isotropy	±9.6%	Rectangular	$\sqrt{3}$	0.7	0.7	±3.9%	±3.9%	
u4	Boundary Effect	±2.0%	Rectangular	$\sqrt{3}$	1	1	±1.2%	±1.2%	∞
u5	Linearity	±4.7%	Rectangular	$\sqrt{3}$	1	1	±2.7%	±2.7%	∞
u6	System Detection Limit	±1.0%	Rectangular	$\sqrt{3}$	1	1	±0.6%	±0.6%	∞
u7	Readout Electronics	±0.0%	Normal	1	1	1	±0.0%	±0.0%	∞
u8	Response Time	±0.8%	Rectangular	$\sqrt{3}$	1	1	±0.5%	±0.5%	∞
u9	Integration Time	±2.8%	Rectangular	$\sqrt{3}$	1	1	±2.8%	±2.8%	∞
u10	RF Ambient Conditions	±3.0%	Rectangular	$\sqrt{3}$	1	1	±1.7%	±1.7%	∞
u11	RF Ambient Reflections	±3.0%	Rectangular	$\sqrt{3}$	1	1	±1.7%	±1.7%	∞
u12	Probe Positioner Mechanical Tolerance	±0.7%	Rectangular	$\sqrt{3}$	1	1	±0.7%	±0.7%	∞
u13	Probe Positioning with respect to Phantom Shell	±9.9%	Rectangular	$\sqrt{3}$	1	1	±5.7%	±5.7%	∞
u14	Extrapolation, interpolation and integration Algorithms for Max. SAR Evaluation	±3.0%	Rectangular	$\sqrt{3}$	1	1	±1.7%	±1.7%	∞
Test sample Related									
u15	Test sample Positioning	±3.6%	Normal	1	1	1	±3.6%	±3.6%	89
u16	Device Holder Uncertainty	±2.7%	Normal	1	1	1	±2.7%	±2.7%	5
u17	Output Power Variation - SAR drift measurement	±5.0%	Rectangular	$\sqrt{3}$	1	1	±2.9%	±2.9%	∞
Phantom and Tissue Parameters									
u18	Phantom Uncertainty (shape and thickness tolerances)	±4.0%	Rectangular	$\sqrt{3}$	1	1	±2.3%	±2.3%	∞
u19	Liquid Conductivity - deviation from target values	±5.0%	Rectangular	$\sqrt{3}$	0.64	0.43	±1.8%	±1.2%	∞
u20	Liquid Conductivity - measurement uncertainty	±2.5%	Normal	1	0.64	0.43	±1.6%	±1.08%	69
u21	Liquid Permittivity - deviation from target values	±5.0%	Rectangular	$\sqrt{3}$	0.6	0.49	±1.7%	±1.4%	∞
u22	Liquid Permittivity - measurement uncertainty	±2.5%	Normal	1	0.6	0.49	±1.5%	±1.23%	69
Combined standard uncertainty			RSS				±12.84%	±12.65%	313
Expanded uncertainty (95% CONFIDENCE LEVEL)			$k=2$				±25.68%	±25.29%	

Table 7. Uncertainty Budget for frequency range 3GHz to 6GHz



10. Measurement Procedure

The measurement procedures are as follows:

1. For WLAN function, engineering testing software installed on Notebook can provide continuous transmitting signal.
2. Measure output power through RF cable and power meter
3. Set scan area, grid size and other setting on the DASY software
4. Find out the largest SAR result on these testing positions of each band
5. Measure SAR results for other channels in worst SAR testing position if the SAR of highest power channel is larger than 0.8 W/kg

According to the test standard, the recommended procedure for assessing the peak spatial-average SAR value consists of the following steps:

1. Power reference measurement
2. Area scan
3. Zoom scan
4. Power drift measurement

10.1 Spatial Peak SAR Evaluation

The procedure for spatial peak SAR evaluation has been implemented according to the test standard. It can be conducted for 1g and 10g, as well as for user-specific masses. The DASY software includes all numerical procedures necessary to evaluate the spatial peak SAR value.

The base for the evaluation is a "cube" measurement. The measured volume must include the 1g and 10g cubes with the highest averaged SAR values. For that purpose, the center of the measured volume is aligned to the interpolated peak SAR value of a previously performed area scan.

The entire evaluation of the spatial peak values is performed within the post-processing engine (SEMCAD). The system always gives the maximum values for the 1g and 10g cubes. The algorithm to find the cube with highest averaged SAR is divided into the following stages

1. Extraction of the measured data (grid and values) from the Zoom Scan
2. Calculation of the SAR value at every measurement point based on all stored data (A/D values and measurement parameters)
3. Generation of a high-resolution mesh within the measured volume
4. Interpolation of all measured values from the measurement grid to the high-resolution grid
5. Extrapolation of the entire 3-D field distribution to the phantom surface over the distance from sensor to surface
6. Calculation of the averaged SAR within masses of 1g and 10g



10.2 Area & Zoom Scan Procedures

First Area Scan is used to locate the approximate location(s) of the local peak SAR value(s). The measurement grid within an Area Scan is defined by the grid extent, grid step size and grid offset. Next, in order to determine the EM field distribution in a three-dimensional spatial extension, Zoom Scan is required. The Zoom Scan measures points and step size follow as below. The Zoom Scan is performed around the highest E-field value to determine the averaged SAR-distribution over 10 g.

Grid Type	Frequency		Step size (mm)			X*Y*Z (Point)	Cube size			Step size		
			X	Y	Z		X	Y	Z	X	Y	Z
uniform grid	≤ 3GHz	≤ 2GHz	≤ 8	≤ 8	≤ 5	5*5*7	32	32	30	8	8	5
		2G - 3G	≤ 5	≤ 5	≤ 5	7*7*7	30	30	30	5	5	5
	3 - 6GHz	3 - 4GHz	≤ 5	≤ 5	≤ 4	7*7*8	30	30	28	5	5	4
		4 - 5GHz	≤ 4	≤ 4	≤ 3	8*8*10	28	28	27	4	4	3
		5 - 6GHz	≤ 4	≤ 4	≤ 2	8*8*12	28	28	22	4	4	2

(Our measure settings are refer KDB Publication 865664 D01v01r04)

10.3 Volume Scan Procedures

The volume scan is used for assess overlapping SAR distributions for antennas transmitting in different frequency bands. It is equivalent to an oversized zoom scan used in standalone measurements. The measurement volume will be used to enclose all the simultaneous transmitting antennas. For antennas transmitting simultaneously in different frequency bands, the volume scan is measured separately in each frequency band. In order to sum correctly to compute the 1g aggregate SAR, the DUT remain in the same test position for all measurements and all volume scan use the same spatial resolution and grid spacing. When all volume scan were completed, the software, SEMCAD postprocessor can combine and subsequently superpose these measurement data to calculating the multiband SAR.

10.4 SAR Averaged Methods

In DASYS, the interpolation and extrapolation are both based on the modified Quadratic Shepard's method. The interpolation scheme combines a least-square fitted function method and a weighted average method which are the two basic types of computational interpolation and approximation. Extrapolation routines are used to obtain SAR values between the lowest measurement points and the inner phantom surface. The extrapolation distance is determined by the surface detection distance and the probe sensor offset. The uncertainty increases with the extrapolation distance. To keep the uncertainty within 1% for the 1 g and 10 g cubes, the extrapolation distance should not be larger than 5 mm.

10.5 Power Drift Monitoring

All SAR testing is under the DUT install full charged battery and transmit maximum output power. In DASYS measurement software, the power reference measurement and power drift measurement procedures are used for monitoring the power drift of DUT during SAR test. Both these procedures measure the field at a specified reference position before and after the SAR testing. The software will calculate the field difference in dB. If the power drift more than 5%, the SAR will be retested.



11. SAR Test Results Summary

1. According KDB 447498 D01 V06 section 4.1.4, the "Reported" explanation as below:
"When SAR or MPE is measured at or scaled to the maximum tune-up tolerance limit, the results are referred to as reported."
2. If actual power less than tune-up power that Scaling SAR is required.
3. The formula of Reported SAR, that represent as below:
Reported SAR = Original SAR * 10[^][(Tune-up power - Actual power)/10]
4. Require the middle channel to be tested first, if the maximum output power variation across the required test channels is > ½ dB, instead of the middle channel, the highest output power channel must be used.
5. A test separation distance of 5 mm is required between the phantom and all surfaces and edges with a transmitting antenna located within 25 mm from that surface or edge.
6. When the maximum output power and tune-up tolerance specified for production units in a secondary mode is ≤ ¼ dB higher than the primary mode or when the highest reported SAR of the primary mode is scaled by the ratio of specified maximum output power and tune-up tolerance of secondary to primary mode and the adjusted SAR is ≤ 1.2 W/kg, SAR measurement is not required for the secondary mode.
7. SAR test reduction for GPRS and EDGE modes is determined by the source-based time-averaged output power.
8. The 3G SAR test reduction procedure is applied to 8-PSK EDGE with GMSK GPRS/EDGE as the primary mode.
9. The 3G SAR test reduction procedure is applied to HSPA (HSUPA/HSDPA with RMC) configurations with 12.2 kbps RMC as the primary mode.
10. The device is designed to WWAN and WLAN can not be transmitted simultaneously, combine SAR is not required.

11.1 Head Measurement SAR

Index.	Position	Band	Ch.	Data Rate or Sub-Test	Test Position	Spacing (mm)	SAR _{1g} (W/kg)	Power Drift	Burst Avg Power	Max tune-up	Reported SAR _{1g} (W/kg)
#24	Flat	GSM 850	190	1Down1Up	Side 1	25	0.013	-0.02	33.01	33.5	0.02
#21	Flat	GSM 1900	661	1Down1Up	Side 1	25	0.00286	0.04	30.42	31	0.00
#22	Flat	WCDMA Band II	9400	RMC-12.2K	Side 1	25	0.011	-0.18	23.64	24	0.01
#23	Flat	WCDMA Band V	4183	RMC-12.2K	Side 1	25	0.041	-0.07	23.64	24	0.05



11.2 Body Measurement SAR

Index.	Position	Band	Ch.	Data Rate or Sub-Test	Test Position	Spacing (mm)	SAR _{1g} (W/kg)	Power Drift	Burst Avg Power	Max tune-up	Reported SAR _{1g} (W/kg)
#1	Flat	GPRS 850	190	1Down4Up	Side 1	5	0.226	-0.13	31.26	31.5	0.24
#2	Flat	GPRS 850	190	1Down4Up	Side 2	5	0.676	-0.01	31.26	31.5	0.71
#3	Flat	GPRS 850	190	1Down4Up	Side 3	5	0.158	0.12	31.26	31.5	0.17
#4	Flat	GPRS 850	190	1Down4Up	Side 5	5	0.272	-0.15	31.26	31.5	0.29
#5	Flat	GPRS 850	190	1Down4Up	Side 6	5	0.121	-0.18	31.26	31.5	0.13
#25	Flat	GPRS 850	190	1Down4Up	Side2 (with holder)	0	0.48	-0.17	31.26	31.5	0.51
#11	Flat	GPRS 1900	661	1Down4Up	Side 1	5	0.091	-0.12	28.06	29	0.11
#12	Flat	GPRS 1900	661	1Down4Up	Side 2	5	0.492	-0.14	28.06	29	0.61
#13	Flat	GPRS 1900	661	1Down4Up	Side 3	5	0.493	0.11	28.06	29	0.61
#14	Flat	GPRS 1900	661	1Down4Up	Side 5	5	0.076	-0.18	28.06	29	0.09
#15	Flat	GPRS 1900	661	1Down4Up	Side 6	5	0.099	-0.14	28.06	29	0.12
#26	Flat	GPRS 1900	661	1Down4Up	Side2 (with holder)	0	0.143	-0.17	28.06	29	0.18
#16	Flat	WCDMA Band II	9400	RMC-12.2K	Side 1	5	0.055	-0.1	23.64	24	0.06
#17	Flat	WCDMA Band II	9400	RMC-12.2K	Side 2	5	0.318	-0.17	23.64	24	0.35
#18	Flat	WCDMA Band II	9400	RMC-12.2K	Side 3	5	0.383	0.06	23.64	24	0.42
#19	Flat	WCDMA Band II	9400	RMC-12.2K	Side 5	5	0.06	0.12	23.64	24	0.07
#20	Flat	WCDMA Band II	9400	RMC-12.2K	Side 6	5	0.054	-0.17	23.64	24	0.06
#6	Flat	WCDMA Band V	4183	RMC-12.2K	Side 1	5	0.169	0.05	23.64	24	0.18
#7	Flat	WCDMA Band V	4183	RMC-12.2K	Side 2	5	0.35	0.03	23.64	24	0.38
#8	Flat	WCDMA Band V	4183	RMC-12.2K	Side 3	5	0.152	0.11	23.64	24	0.17
#9	Flat	WCDMA Band V	4183	RMC-12.2K	Side 5	5	0.155	-0.05	23.64	24	0.17
#10	Flat	WCDMA Band V	4183	RMC-12.2K	Side 6	5	0.084	0.05	23.64	24	0.09
#27	Flat	WCDMA Band V	4183	RMC-12.2K	Side2 (with holder)	0	0.211	-0.03	23.64	24	0.23



11.3 Hot-spot mode Measurement SAR

This device does not support Hot-spot mode.

11.4 Extremity Measurement SAR

Evaluated extremity SAR is not available.

11.5 Std. C95.1-1992 RF Exposure Limit

Human Exposure	Population Uncontrolled Exposure (W/kg) or (mW/g)	Occupational Controlled Exposure (W/kg) or (mW/g)
Spatial Peak SAR* (head)	1.60	8.00
Spatial Peak SAR** (Whole Body)	0.08	0.40
Spatial Peak SAR*** (Partial-Body)	1.60	8.00
Spatial Peak SAR**** (Hands / Feet / Ankle / Wrist)	4.00	20.00

Table 8. Safety Limits for Partial Body Exposure

Notes :

- * The Spatial Peak value of the SAR averaged over any 1 gram of tissue. (defined as a tissue volume in the shape of a cube) and over the appropriate averaging time.
- ** The Spatial Average value of the SAR averaged over the whole – body.
- *** The Spatial Average value of the SAR averaged over the partial – body.
- **** The Spatial Peak value of the SAR averaged over any 10 grams of tissue. (defined as a tissue volume in the shape of a cube) and over the appropriate averaging time.

Population / Uncontrolled Environments : are defined as locations where there is the exposure of individuals who have no knowledge or control of their exposure.

Occupational / Controlled Environments : are defined as locations where there is exposure that may be incurred by persons who are aware of the potential for exposure, (i.e. as a result of employment or occupation).



12. References

- [1] Std. C95.1-1999, "American National Standard safety levels with respect to human exposure to radio frequency electromagnetic fields, 300KHz to 100GHz", New York.
- [2] NCRP, National Council on Radiation Protection and Measurements, "Biological Effects and Exposure Criteria for Radio frequency Electromagnetic Fields", NCRP report NO. 86, 1986.
- [3] T. Schmid, O. Egger, and N. Kuster, "Automatic E-field scanning system for dosimetric assessments", IEEE Transactions on Microwave Theory and Techniques, vol. 44, pp, 105-113, Jan. 1996.
- [4] K. Pokovi^c, T. Schmid, and N. Kuster, "Robust setup for precise calibration of E-field probes in tissue simulating liquids at mobile communications frequency", in ICECOM'97, Dubrovnik, October 15-17, 1997, pp.120-124.
- [5] K. Pokovi^c, T. Schmid, and N. Kuster, "E-field probe with improved isotropy in brain simulating liquids", in Proceedings of the ELMAR, Zadar, Croatia, 23-25 June, 1996, pp.172-175.
- [6] N. Kuster, and Q. Balzano, "Energy absorption mechanism by biological bodies in the near field of dipole antennas above 300MHz", IEEE Transaction on Vehicular Technology, vol. 41, no. 1, Feb. 1992, pp. 17-23.
- [7] Robert J. Renka, "Multivariate Interpolation Of Large Sets Of Scattered Data", University of North Texas ACM Transactions on Mathematical Software, vol. 14, no. 2, June 1988 , pp. 139-148.
- [8] N. Kuster, R. Kastle, T. Schmid, Dosimetric evaluation of mobile communications equipment with known precision, IEEE Transaction on Communications, vol. E80-B, no. 5, May 1997, pp. 645-652.
- [9] Std. C95.3-1991, "IEEE Recommended Practice for the Measurement of Potentially Hazardous Electromagnetic Fields – RF and Microwave, New York: IEEE, Aug. 1992.
- [10] CENELEC CLC/SC111B, European Prestandard (prENV 50166-2), Human Exposure to Electromagnetic Fields High-frequency: 10KHz-300GHz, Jan. 1995.
- [11] IEEE Std 1528™-2013 - IEEE Recommended Practice for Determining the Peak Spatial-Average Specific Absorption Rate (SAR) in the Human Head From Wireless Communications Devices: Measurement Techniques



Appendix A - System Performance Check

Test Laboratory: A Test Lab Techno Corp.

Date/Time: 2016/11/23 PM 10:31:11

System Performance Check at 835MHz_20161123_Head

DUT: Dipole 835 MHz; Type: D835V2; Serial: D835V2 - SN:4d082

Communication System: UID 0, CW (0); Frequency: 835 MHz; Duty Cycle: 1:1

Medium parameters used: $f = 835$ MHz; $\sigma = 0.915$ S/m; $\epsilon_r = 41.943$; $\rho = 1000$ kg/m³

Phantom section: Flat Section

Measurement Standard: DASYS5 (IEEE/IEC/ANSI C63.19-2011)

DASY5.2 Configuration:

- Area Scan setting - Find Secondary Maximum Within: 2.0dB and with a peak SAR value greater than 0.5 W/Kg
- Probe: EX3DV4 - SN3977; ConvF(9.62, 9.62, 9.62); Calibrated: 2016/3/9;
- Sensor-Surface: 2mm (Mechanical Surface Detection)
- Electronics: DAE4 Sn779; Calibrated: 2016/3/2
- Phantom: ELI v4.0; Type: QDOVA001BB; Serial: TP:1036
- Measurement SW: DASYS5, Version 52.8 (8); SEMCAD X Version 14.6.10 (7331)

System Performance Check at 835MHz/Area Scan (61x121x1):

Interpolated grid: $dx=1.500$ mm, $dy=1.500$ mm

Maximum value of SAR (interpolated) = 3.07 W/kg

System Performance Check at 835MHz/Zoom Scan (7x7x7)/Cube 0:

Measurement grid: $dx=5$ mm, $dy=5$ mm, $dz=5$ mm

Reference Value = 58.86 V/m; Power Drift = -0.02 dB

Peak SAR (extrapolated) = 3.65 W/kg

SAR(1 g) = 2.38 W/kg; SAR(10 g) = 1.55 W/kg

Maximum value of SAR (measured) = 3.06 W/kg

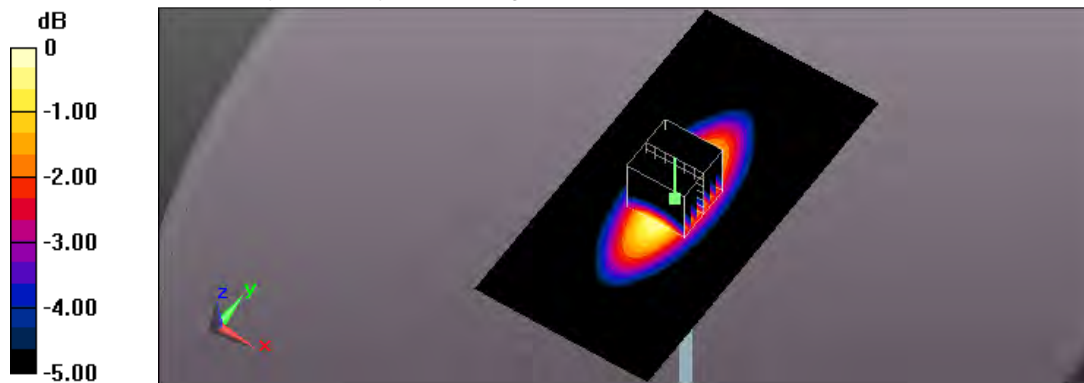

0 dB = 3.06 W/kg = 4.86 dBW/kg

Test Laboratory: A Test Lab Techno Corp.
 Date/Time: 2016/11/23 AM 02:59:34
 System Performance Check at 835MHz_20161123_Body
 DUT: Dipole 835 MHz; Type: D835V2; Serial: D835V2 - SN:4d082

Communication System: UID 0, CW (0); Frequency: 835 MHz; Duty Cycle: 1:1
 Medium parameters used: $f = 835 \text{ MHz}$; $\sigma = 0.968 \text{ S/m}$; $\epsilon_r = 54.329$; $\rho = 1000 \text{ kg/m}^3$
 Phantom section: Flat Section
 Measurement Standard: DASYS5 (IEEE/IEC/ANSI C63.19-2011)

DASY5.2 Configuration:

- Area Scan setting - Find Secondary Maximum Within: 2.0dB and with a peak SAR value greater than 0.5 W/Kg
- Probe: EX3DV4 - SN3977; ConvF(9.82, 9.82, 9.82); Calibrated: 2016/3/9;
- Sensor-Surface: 2mm (Mechanical Surface Detection)
- Electronics: DAE4 Sn779; Calibrated: 2016/3/2
- Phantom: ELI v4.0; Type: QDOVA001BB; Serial: TP:1036
- Measurement SW: DASYS5, Version 52.8 (8); SEMCAD X Version 14.6.10 (7331)

System Performance Check at 835MHz/Area Scan (61x121x1):
 Interpolated grid: $dx=1.500 \text{ mm}$, $dy=1.500 \text{ mm}$
 Maximum value of SAR (interpolated) = 3.01 W/kg

System Performance Check at 835MHz/Zoom Scan (7x7x7)/Cube 0:
 Measurement grid: $dx=5\text{mm}$, $dy=5\text{mm}$, $dz=5\text{mm}$
 Reference Value = 56.72 V/m; Power Drift = 0.01 dB
 Peak SAR (extrapolated) = 3.53 W/kg
 SAR(1 g) = 2.37 W/kg; SAR(10 g) = 1.56 W/kg
 Maximum value of SAR (measured) = 3.00 W/kg

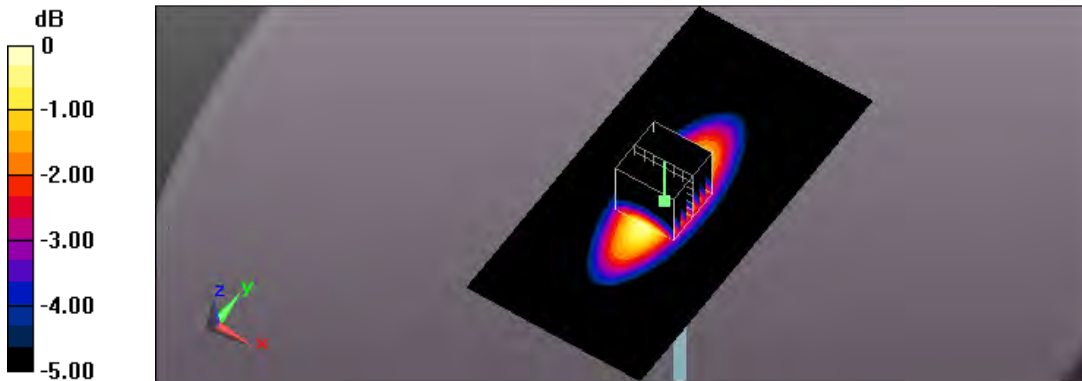

0 dB = 3.00 W/kg = 4.77 dBW/kg

Test Laboratory: A Test Lab Techno Corp.
 Date/Time: 2016/12/5 PM 05:07:49
 System Performance Check at 835MHz_20161205_Body
 DUT: Dipole 835 MHz; Type: D835V2; Serial: D835V2 - SN:4d082

Communication System: UID 0, CW (0); Frequency: 835 MHz; Duty Cycle: 1:1
 Medium parameters used: $f = 835 \text{ MHz}$; $\sigma = 0.968 \text{ S/m}$; $\epsilon_r = 54.329$; $\rho = 1000 \text{ kg/m}^3$
 Phantom section: Flat Section
 Measurement Standard: DASYS5 (IEEE/IEC/ANSI C63.19-2011)

DASY5.2 Configuration:

- Area Scan setting - Find Secondary Maximum Within: 2.0dB and with a peak SAR value greater than 0.5 W/Kg
- Probe: EX3DV4 - SN3977; ConvF(9.82, 9.82, 9.82); Calibrated: 2016/3/9;
- Sensor-Surface: 2mm (Mechanical Surface Detection)
- Electronics: DAE4 Sn779; Calibrated: 2016/3/2
- Phantom: ELI v4.0; Type: QDOVA001BB; Serial: TP:1036
- Measurement SW: DASYS52, Version 52.8 (8); SEMCAD X Version 14.6.10 (7331)

System Performance Check at 835MHz/Area Scan (61x121x1):
 Interpolated grid: $dx=1.500 \text{ mm}$, $dy=1.500 \text{ mm}$
 Maximum value of SAR (interpolated) = 2.99 W/kg

System Performance Check at 835MHz/Zoom Scan (7x7x7)/Cube 0:
 Measurement grid: $dx=5\text{mm}$, $dy=5\text{mm}$, $dz=5\text{mm}$
 Reference Value = 56.69 V/m; Power Drift = -0.08 dB
 Peak SAR (extrapolated) = 3.49 W/kg
 SAR(1 g) = 2.35 W/kg; SAR(10 g) = 1.54 W/kg
 Maximum value of SAR (measured) = 2.97 W/kg

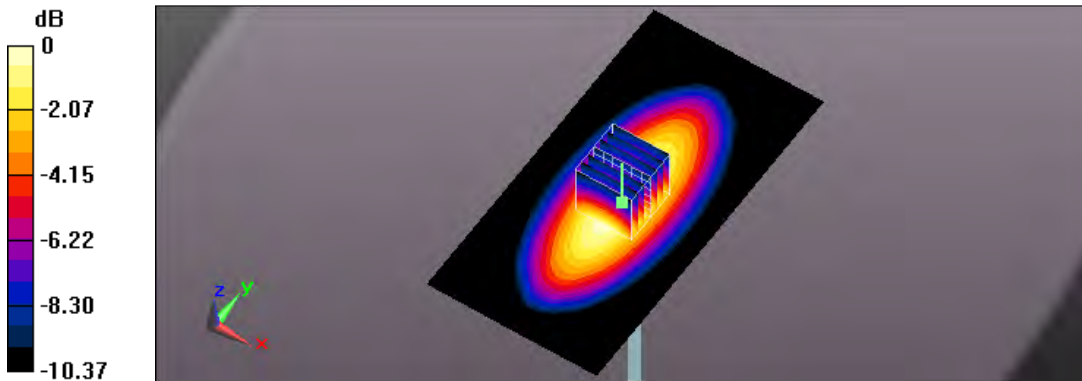

0 dB = 2.97 W/kg = 4.73 dBW/kg

Test Laboratory: A Test Lab Techno Corp.
 Date/Time: 2016/11/23 PM 08:03:49
 System Performance Check at 1900MHz_20161123_Head
 DUT: Dipole D1900V2_SN5d111; Type: D1900V2; Serial: D1900V2 - SN:5d111

Communication System: UID 0, CW (0); Frequency: 1900 MHz; Duty Cycle: 1:1
 Medium parameters used: $f = 1900$ MHz; $\sigma = 1.392$ S/m; $\epsilon_r = 40.7$; $\rho = 1000$ kg/m³
 Phantom section: Flat Section
 Measurement Standard: DASYS5 (IEEE/IEC/ANSI C63.19-2011)

DASY5.2 Configuration:

- Area Scan setting - Find Secondary Maximum Within: 2.0dB and with a peak SAR value greater than 0.5 W/Kg
- Probe: EX3DV4 - SN3977; ConvF(8.02, 8.02, 8.02); Calibrated: 2016/3/9;
- Sensor-Surface: 2mm (Mechanical Surface Detection)
- Electronics: DAE4 Sn779; Calibrated: 2016/3/2
- Phantom: ELI v4.0; Type: QDOVA001BB; Serial: TP:1036
- Measurement SW: DASYS52, Version 52.8 (8); SEMCAD X Version 14.6.10 (7331)

System Performance Check at 1900MHz/Area Scan (61x61x1):
 Interpolated grid: dx=1.500 mm, dy=1.500 mm
 Maximum value of SAR (interpolated) = 14.9 W/kg

System Performance Check at 1900MHz/Zoom Scan (7x7x7)/Cube 0:
 Measurement grid: dx=5mm, dy=5mm, dz=5mm
 Reference Value = 104.5 V/m; Power Drift = -0.03 dB
 Peak SAR (extrapolated) = 19.2 W/kg
 SAR(1 g) = 10.3 W/kg; SAR(10 g) = 5.3 W/kg
 Maximum value of SAR (measured) = 15.0 W/kg

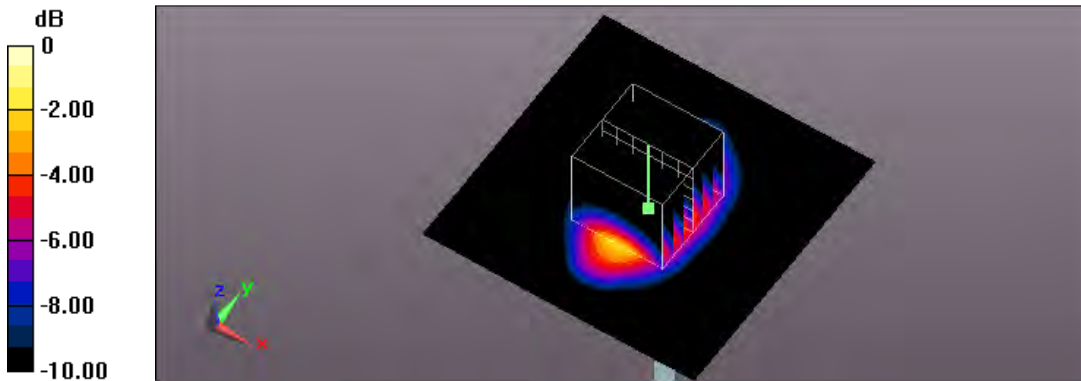

0 dB = 15.0 W/kg = 11.76 dBW/kg



Test Laboratory: A Test Lab Techno Corp.
Date/Time: 2016/11/23 PM 01:44:14
System Performance Check at 1900MHz_20161123_Body
DUT: Dipole D1900V2_SN5d111; Type: D1900V2; Serial: D1900V2 - SN:5d111

Communication System: UID 0, CW (0); Frequency: 1900 MHz;Duty Cycle: 1:1
Medium parameters used: $f = 1900$ MHz; $\sigma = 1.583$ S/m; $\epsilon_r = 52.147$; $\rho = 1000$ kg/m³
Phantom section: Flat Section
Measurement Standard: DASYS5 (IEEE/IEC/ANSI C63.19-2011)

DASY5.2 Configuration:

- Area Scan setting - Find Secondary Maximum Within:2.0dB and with a peak SAR value greater than 0.5 W/Kg
- Probe: EX3DV4 - SN3977; ConvF(7.66, 7.66, 7.66); Calibrated: 2016/3/9;
- Sensor-Surface: 2mm (Mechanical Surface Detection)
- Electronics: DAE4 Sn779; Calibrated: 2016/3/2
- Phantom: ELI v4.0; Type: QDOVA001BB; Serial: TP:1036
- Measurement SW: DASYS52, Version 52.8 (8); SEMCAD X Version 14.6.10 (7331)

System Performance Check at 1900MHz/Area Scan (61x61x1):
Interpolated grid: dx=1.500 mm, dy=1.500 mm
Maximum value of SAR (interpolated) = 14.2 W/kg

System Performance Check at 1900MHz/Zoom Scan (7x7x7)/Cube 0:
Measurement grid: dx=5mm, dy=5mm, dz=5mm
Reference Value = 97.95 V/m; Power Drift = -0.05 dB
Peak SAR (extrapolated) = 17.7 W/kg
SAR(1 g) = 9.93 W/kg; SAR(10 g) = 5.11 W/kg
Maximum value of SAR (measured) = 14.3 W/kg

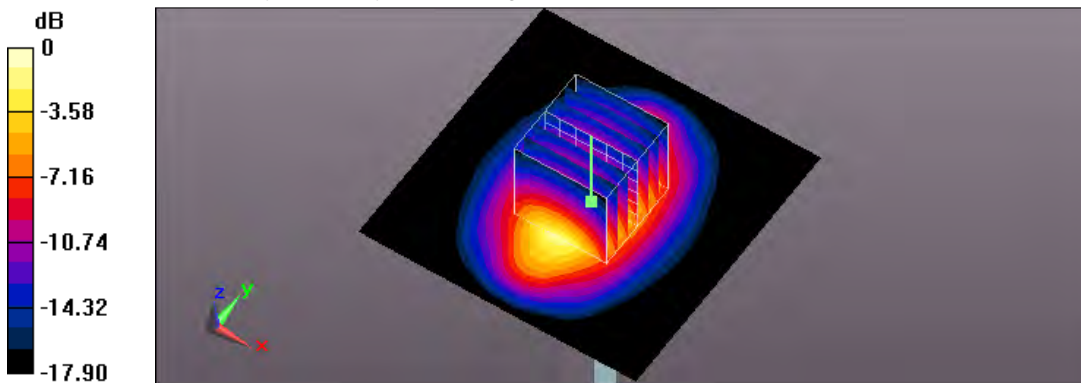

0 dB = 14.3 W/kg = 11.55 dBW/kg

Test Laboratory: A Test Lab Techno Corp.
 Date/Time: 2016/12/5 PM 06:58:49
 System Performance Check at 1900MHz_20161205_Body
 DUT: Dipole D1900V2_SN5d111; Type: D1900V2; Serial: D1900V2 - SN:5d111

Communication System: UID 0, CW (0); Frequency: 1900 MHz; Duty Cycle: 1:1
 Medium parameters used: $f = 1900$ MHz; $\sigma = 1.583$ S/m; $\epsilon_r = 52.147$; $\rho = 1000$ kg/m³
 Phantom section: Flat Section
 Measurement Standard: DASYS5 (IEEE/IEC/ANSI C63.19-2011)

DASY5.2 Configuration:

- Area Scan setting - Find Secondary Maximum Within: 2.0dB and with a peak SAR value greater than 0.5 W/Kg
- Probe: EX3DV4 - SN3977; ConvF(7.66, 7.66, 7.66); Calibrated: 2016/3/9;
- Sensor-Surface: 2mm (Mechanical Surface Detection)
- Electronics: DAE4 Sn779; Calibrated: 2016/3/2
- Phantom: ELI v4.0; Type: QDOVA001BB; Serial: TP:1036
- Measurement SW: DASYS52, Version 52.8 (8); SEMCAD X Version 14.6.10 (7331)

System Performance Check at 1900MHz/Area Scan (61x61x1):
 Interpolated grid: dx=1.500 mm, dy=1.500 mm
 Maximum value of SAR (interpolated) = 13.9 W/kg

System Performance Check at 1900MHz/Zoom Scan (7x7x7)/Cube 0:
 Measurement grid: dx=5mm, dy=5mm, dz=5mm
 Reference Value = 97.47 V/m; Power Drift = 0.07 dB
 Peak SAR (extrapolated) = 18.0 W/kg
 SAR(1 g) = 10.1 W/kg; SAR(10 g) = 5.21 W/kg
 Maximum value of SAR (measured) = 14.5 W/kg

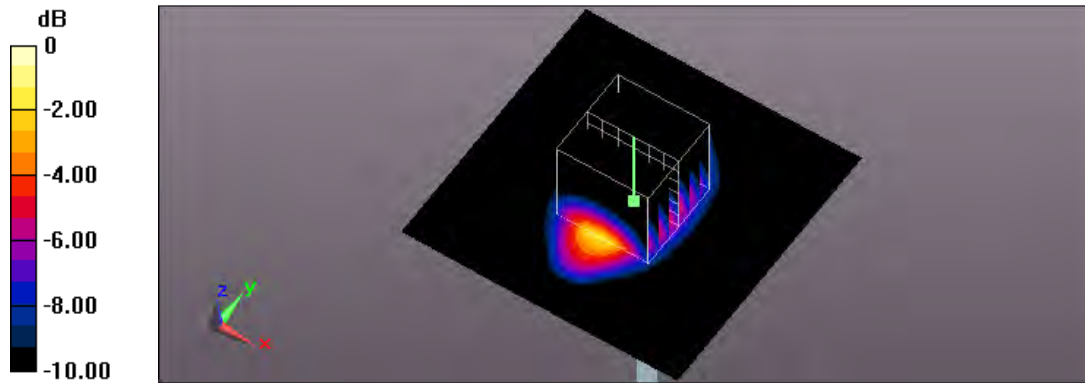

0 dB = 14.5 W/kg = 11.61 dBW/kg

Appendix B - SAR Measurement Data

Test Laboratory: A Test Lab Techno Corp.

Date/Time: 2016/11/24 AM 12:35:37

24_GSM 850 CH190_1D1U_Side1_25mm

DUT: BR828PGTW ; Type: POC SAG ALPHANUMERIC PAGER with 3G/GSM, GPS & Wi-Fi ; FCC ID: VDQ828-02

Communication System: UID 0, GSM850 (0); Frequency: 836.6 MHz; Duty Cycle: 1:8

Medium parameters used: $f = 837$ MHz; $\sigma = 0.917$ S/m; $\epsilon_r = 41.926$; $\rho = 1000$ kg/m³

Phantom section: Flat Section

Measurement Standard: DASYS5 (IEEE/IEC/ANSI C63.19-2011)

DASY5.2 Configuration:

- Area Scan setting - Find Secondary Maximum Within: 2.0dB and with a peak SAR value greater than 0.5 W/Kg
- Probe: EX3DV4 - SN3977; ConvF(9.62, 9.62, 9.62); Calibrated: 2016/3/9;
- Sensor-Surface: 2mm (Mechanical Surface Detection)
- Electronics: DAE4 Sn779; Calibrated: 2016/3/2
- Phantom: ELI v4.0; Type: QDOVA001BB; Serial: TP:1036
- Measurement SW: DASYS5, Version 52.8 (8); SEMCAD X Version 14.6.10 (7331)

Flat/Area Scan (81x91x1):

Interpolated grid: dx=1.500 mm, dy=1.500 mm

Maximum value of SAR (interpolated) = 0.0158 W/kg

Flat/Zoom Scan (5x5x7)/Cube 0:

Measurement grid: dx=8mm, dy=8mm, dz=5mm

Reference Value = 3.450 V/m; Power Drift = -0.02 dB

Peak SAR (extrapolated) = 0.0180 W/kg

SAR(1 g) = 0.013 W/kg; SAR(10 g) = 0.00895 W/kg

Maximum value of SAR (measured) = 0.0154 W/kg

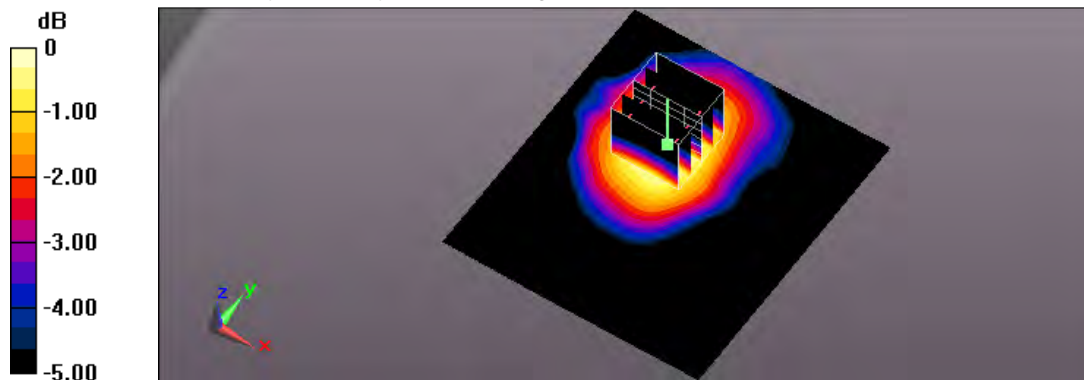

Test Laboratory: A Test Lab Techno Corp.

Date/Time: 2016/11/23 PM 08:31:23

21_GSM 1900 CH661_1D1U_Side1_25mm

DUT: BR828PGTW ; Type: POCSAG ALPHANUMERIC PAGER with 3G/GSM, GPS & Wi-Fi ; FCC ID: VDQ828-02

Communication System: UID 0, PCS (0); Frequency: 1880 MHz; Duty Cycle: 1:8

Medium parameters used: $f = 1880$ MHz; $\sigma = 1.371$ S/m; $\epsilon_r = 40.783$; $\rho = 1000$ kg/m³

Phantom section: Flat Section

Measurement Standard: DASYS5 (IEEE/IEC/ANSI C63.19-2011)

DASY5.2 Configuration:

- Area Scan setting - Find Secondary Maximum Within: 2.0dB and with a peak SAR value greater than 0.5 W/Kg
- Probe: EX3DV4 - SN3977; ConvF(8.02, 8.02, 8.02); Calibrated: 2016/3/9;
- Sensor-Surface: 2mm (Mechanical Surface Detection)
- Electronics: DAE4 Sn779; Calibrated: 2016/3/2
- Phantom: ELI v4.0; Type: QDOVA001BB; Serial: TP:1036
- Measurement SW: DASYS52, Version 52.8 (8); SEMCAD X Version 14.6.10 (7331)

Flat/Area Scan (81x91x1):

Interpolated grid: dx=1.500 mm, dy=1.500 mm

Maximum value of SAR (interpolated) = 0.00395 W/kg

Flat/Zoom Scan (5x5x7)/Cube 0:

Measurement grid: dx=8mm, dy=8mm, dz=5mm

Reference Value = 0.6560 V/m; Power Drift = 0.04 dB

Peak SAR (extrapolated) = 0.00434 W/kg

SAR(1 g) = 0.00286 W/kg; SAR(10 g) = 0.00216 W/kg

Maximum value of SAR (measured) = 0.00358 W/kg

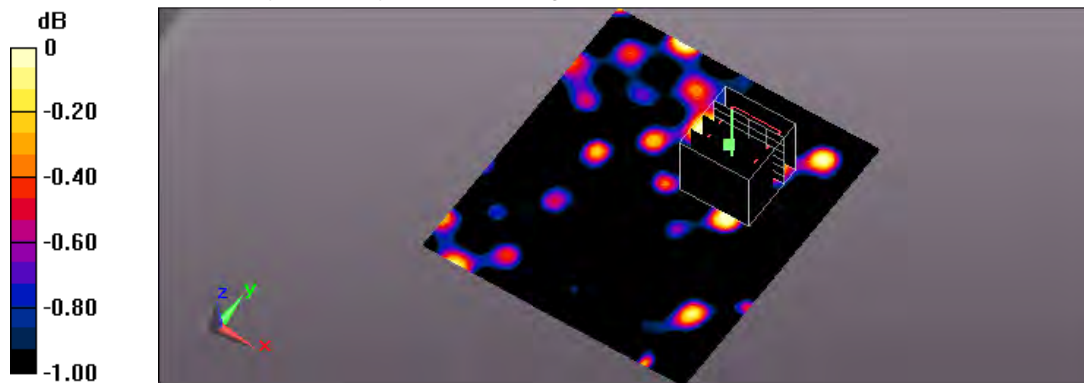

0 dB = 0.00358 W/kg = -24.46 dBW/kg

Test Laboratory: A Test Lab Techno Corp.

Date/Time: 2016/11/23 PM 09:23:31

22_WCDMA Band II CH9400_Side1_25mm

DUT: BR828PGTW ; Type: POCSAG ALPHANUMERIC PAGER with 3G/GSM, GPS & Wi-Fi ; FCC ID: VDQ828-02

Communication System: UID 0, WCDMA Band II (0); Frequency: 1880 MHz;Duty Cycle: 1:1

Medium parameters used: $f = 1880$ MHz; $\sigma = 1.371$ S/m; $\epsilon_r = 40.783$; $\rho = 1000$ kg/m³

Phantom section: Flat Section

Measurement Standard: DASYS5 (IEEE/IEC/ANSI C63.19-2011)

DASY5.2 Configuration:

- Area Scan setting - Find Secondary Maximum Within:2.0dB and with a peak SAR value greater than 0.5 W/Kg
- Probe: EX3DV4 - SN3977; ConvF(8.02, 8.02, 8.02); Calibrated: 2016/3/9;
- Sensor-Surface: 2mm (Mechanical Surface Detection)
- Electronics: DAE4 Sn779; Calibrated: 2016/3/2
- Phantom: ELI v4.0; Type: QDOVA001BB; Serial: TP:1036
- Measurement SW: DASYS52, Version 52.8 (8); SEMCAD X Version 14.6.10 (7331)

Flat/Area Scan (81x91x1):

Interpolated grid: dx=1.500 mm, dy=1.500 mm

Maximum value of SAR (interpolated) = 0.0154 W/kg

Flat/Zoom Scan (5x5x7)/Cube 0:

Measurement grid: dx=8mm, dy=8mm, dz=5mm

Reference Value = 1.015 V/m; Power Drift = -0.18 dB

Peak SAR (extrapolated) = 0.0170 W/kg

SAR(1 g) = 0.011 W/kg; SAR(10 g) = 0.00721 W/kg

Maximum value of SAR (measured) = 0.0136 W/kg

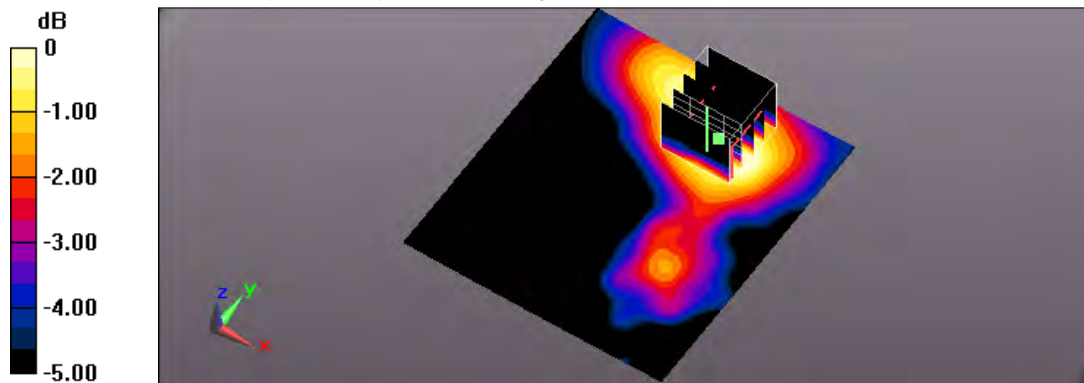

0 dB = 0.0136 W/kg = -18.66 dBW/kg

Test Laboratory: A Test Lab Techno Corp.

Date/Time: 2016/11/24 AM 12:11:10

23_WCDMA Band V CH4183_Side1_25mm

DUT: BR828PGTW ; Type: POCSAG ALPHANUMERIC PAGER with 3G/GSM, GPS & Wi-Fi ; FCC ID: VDQ828-02

Communication System: UID 0, WCDMA Band V (0); Frequency: 836.6 MHz; Duty Cycle: 1:1

Medium parameters used: $f = 837 \text{ MHz}$; $\sigma = 0.917 \text{ S/m}$; $\epsilon_r = 41.926$; $\rho = 1000 \text{ kg/m}^3$

Phantom section: Flat Section

Measurement Standard: DASYS5 (IEEE/IEC/ANSI C63.19-2011)

DASY5.2 Configuration:

- Area Scan setting - Find Secondary Maximum Within: 2.0dB and with a peak SAR value greater than 0.5 W/Kg
- Probe: EX3DV4 - SN3977; ConvF(9.62, 9.62, 9.62); Calibrated: 2016/3/9;
- Sensor-Surface: 2mm (Mechanical Surface Detection)
- Electronics: DAE4 Sn779; Calibrated: 2016/3/2
- Phantom: ELI v4.0; Type: QDOVA001BB; Serial: TP:1036
- Measurement SW: DASYS5, Version 52.8 (8); SEMCAD X Version 14.6.10 (7331)

Flat/Area Scan (81x91x1):

Interpolated grid: $dx=1.500 \text{ mm}$, $dy=1.500 \text{ mm}$

Maximum value of SAR (interpolated) = 0.0501 W/kg

Flat/Zoom Scan (5x5x7)/Cube 0:

Measurement grid: $dx=8\text{mm}$, $dy=8\text{mm}$, $dz=5\text{mm}$

Reference Value = 6.259 V/m; Power Drift = -0.07 dB

Peak SAR (extrapolated) = 0.0580 W/kg

SAR(1 g) = 0.041 W/kg; SAR(10 g) = 0.029 W/kg

Maximum value of SAR (measured) = 0.0497 W/kg

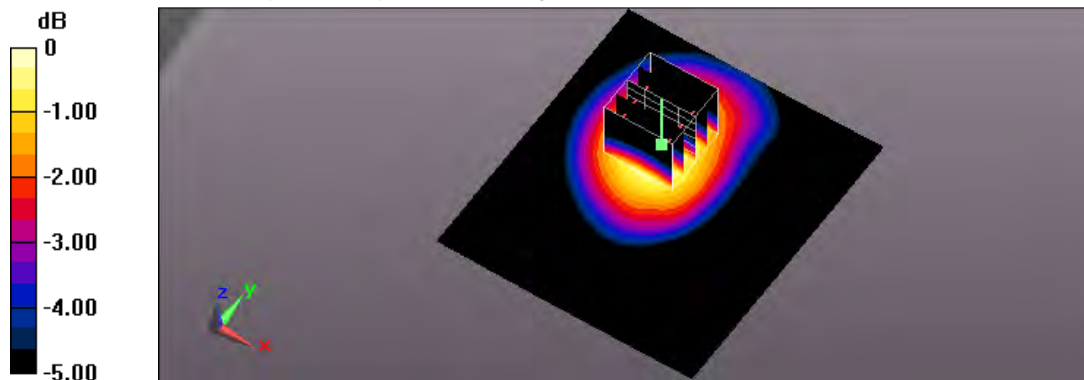

0 dB = 0.0497 W/kg = -13.04 dBW/kg

Test Laboratory: A Test Lab Techno Corp.

Date/Time: 2016/11/23 AM 04:41:31

1_GPRS 850 CH190_1D4U_Side1_5mm

DUT: BR828PGTW ; Type: POCSAG ALPHANUMERIC PAGER with 3G/GSM, GPS & Wi-Fi ; FCC ID: VDQ828-02

Communication System: UID 0, GPRS 850 (1Down, 4Up) (0); Frequency: 836.6 MHz; Duty Cycle: 1:2

Medium parameters used: $f = 837$ MHz; $\sigma = 0.971$ S/m; $\epsilon_r = 54.339$; $\rho = 1000$ kg/m³

Phantom section: Flat Section

Measurement Standard: DASYS5 (IEEE/IEC/ANSI C63.19-2011)

DASY5.2 Configuration:

- Area Scan setting - Find Secondary Maximum Within: 2.0dB and with a peak SAR value greater than 0.5 W/Kg
- Probe: EX3DV4 - SN3977; ConvF(9.82, 9.82, 9.82); Calibrated: 2016/3/9;
- Sensor-Surface: 2mm (Mechanical Surface Detection)
- Electronics: DAE4 Sn779; Calibrated: 2016/3/2
- Phantom: ELI v4.0; Type: QDOVA001BB; Serial: TP:1036
- Measurement SW: DASYS52, Version 52.8 (8); SEMCAD X Version 14.6.10 (7331)

Flat/Area Scan (81x91x1):

Interpolated grid: dx=1.500 mm, dy=1.500 mm

Maximum value of SAR (interpolated) = 0.263 W/kg

Flat/Zoom Scan (5x5x7)/Cube 0:

Measurement grid: dx=8mm, dy=8mm, dz=5mm

Reference Value = 11.88 V/m; Power Drift = -0.13 dB

Peak SAR (extrapolated) = 0.374 W/kg

SAR(1 g) = 0.226 W/kg; SAR(10 g) = 0.145 W/kg

Maximum value of SAR (measured) = 0.287 W/kg

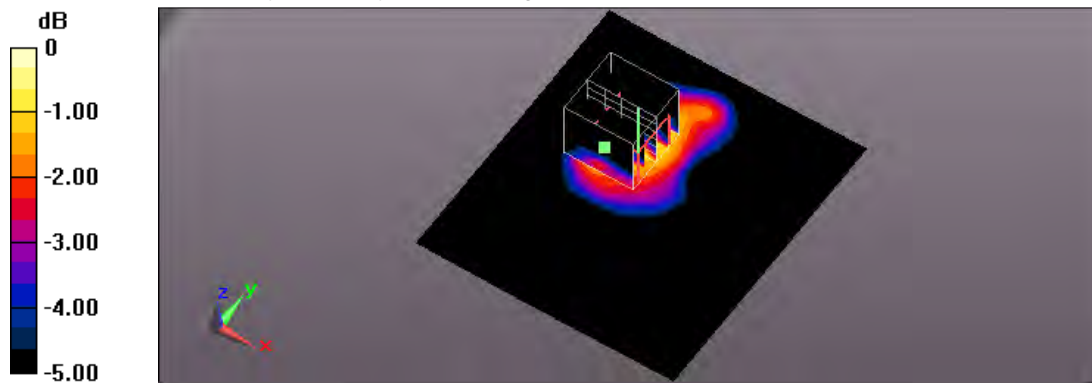

0 dB = 0.287 W/kg = -5.42 dBW/kg

Test Laboratory: A Test Lab Techno Corp.

Date/Time: 2016/11/23 AM 05:08:41

2_GPRS 850 CH190_1D4U_Side2_5mm

DUT: BR828PGTW ; Type: POCSAG ALPHANUMERIC PAGER with 3G/GSM, GPS & Wi-Fi ; FCC ID: VDQ828-02

Communication System: UID 0, GPRS 850 (1Down, 4Up) (0); Frequency: 836.6 MHz; Duty Cycle: 1:2

Medium parameters used: $f = 837 \text{ MHz}$; $\sigma = 0.971 \text{ S/m}$; $\epsilon_r = 54.339$; $\rho = 1000 \text{ kg/m}^3$

Phantom section: Flat Section

Measurement Standard: DASYS5 (IEEE/IEC/ANSI C63.19-2011)

DASY5.2 Configuration:

- Area Scan setting - Find Secondary Maximum Within: 2.0dB and with a peak SAR value greater than 0.5 W/Kg
- Probe: EX3DV4 - SN3977; ConvF(9.82, 9.82, 9.82); Calibrated: 2016/3/9;
- Sensor-Surface: 2mm (Mechanical Surface Detection)
- Electronics: DAE4 Sn779; Calibrated: 2016/3/2
- Phantom: ELI v4.0; Type: QDOVA001BB; Serial: TP:1036
- Measurement SW: DASYS52, Version 52.8 (8); SEMCAD X Version 14.6.10 (7331)

Flat/Area Scan (81x91x1):

Interpolated grid: $dx=1.500 \text{ mm}$, $dy=1.500 \text{ mm}$

Maximum value of SAR (interpolated) = 0.811 W/kg

Flat/Zoom Scan (5x5x7)/Cube 0:

Measurement grid: $dx=8\text{mm}$, $dy=8\text{mm}$, $dz=5\text{mm}$

Reference Value = 28.38 V/m; Power Drift = -0.01 dB

Peak SAR (extrapolated) = 0.914 W/kg

SAR(1 g) = 0.676 W/kg; SAR(10 g) = 0.475 W/kg

Maximum value of SAR (measured) = 0.808 W/kg

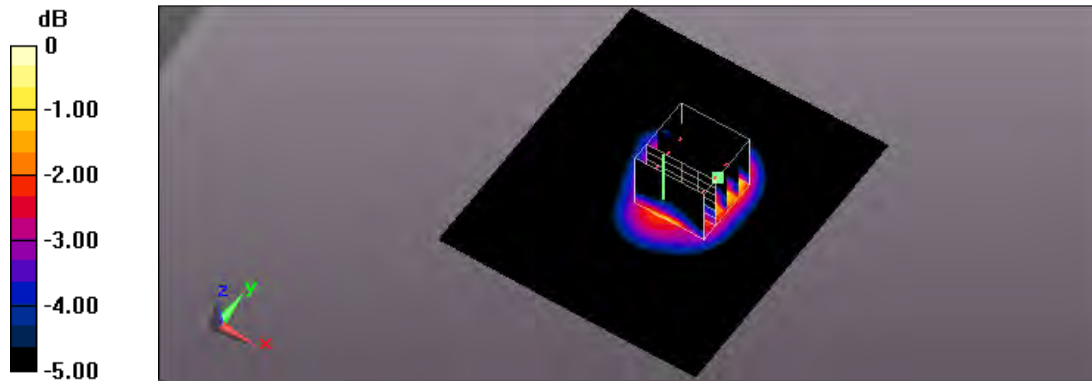

0 dB = 0.636 W/kg = -1.97 dBW/kg

Test Laboratory: A Test Lab Techno Corp.

Date/Time: 2016/11/23 AM 04:12:45

3_GPRS 850 CH190_1D4U_Side3_5mm

DUT: BR828PGTW ; Type: POCSAG ALPHANUMERIC PAGER with 3G/GSM, GPS & Wi-Fi ; FCC ID: VDQ828-02

Communication System: UID 0, GPRS 850 (1Down, 4Up) (0); Frequency: 836.6 MHz; Duty Cycle: 1:2

Medium parameters used: $f = 837$ MHz; $\sigma = 0.971$ S/m; $\epsilon_r = 54.339$; $\rho = 1000$ kg/m³

Phantom section: Flat Section

Measurement Standard: DASYS5 (IEEE/IEC/ANSI C63.19-2011)

DASY5.2 Configuration:

- Area Scan setting - Find Secondary Maximum Within: 2.0dB and with a peak SAR value greater than 0.5 W/Kg
- Probe: EX3DV4 - SN3977; ConvF(9.82, 9.82, 9.82); Calibrated: 2016/3/9;
- Sensor-Surface: 2mm (Mechanical Surface Detection)
- Electronics: DAE4 Sn779; Calibrated: 2016/3/2
- Phantom: ELI v4.0; Type: QDOVA001BB; Serial: TP:1036
- Measurement SW: DASYS52, Version 52.8 (8); SEMCAD X Version 14.6.10 (7331)

Flat/Area Scan (81x91x1):

Interpolated grid: dx=1.500 mm, dy=1.500 mm

Maximum value of SAR (interpolated) = 0.300 W/kg

Flat/Zoom Scan (5x5x7)/Cube 0:

Measurement grid: dx=8mm, dy=8mm, dz=5mm

Reference Value = 15.00 V/m; Power Drift = 0.12 dB

Peak SAR (extrapolated) = 0.265 W/kg

SAR(1 g) = 0.158 W/kg; SAR(10 g) = 0.084 W/kg

Maximum value of SAR (measured) = 0.211 W/kg

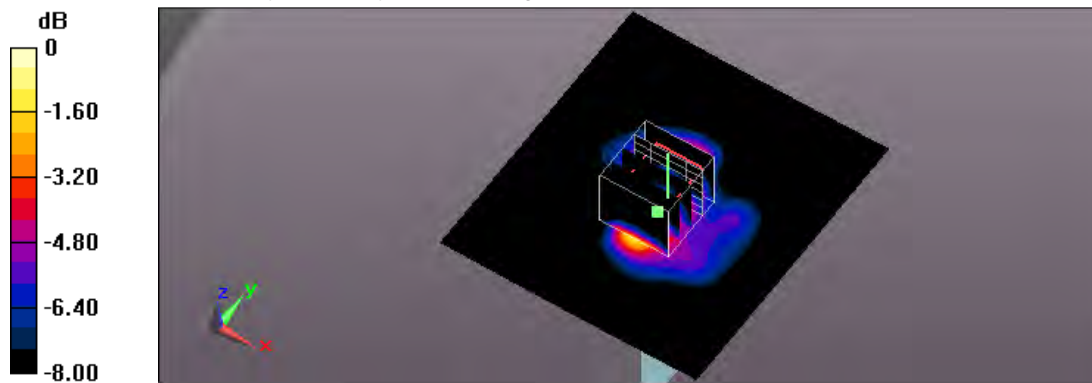

0 dB = 0.211 W/kg = -6.76 dBW/kg

Test Laboratory: A Test Lab Techno Corp.

Date/Time: 2016/11/23 AM 03:33:58

4_GPRS 850 CH190_1D4U_Side5_5mm

DUT: BR828PGTW ; Type: POCSAG ALPHANUMERIC PAGER with 3G/GSM, GPS & Wi-Fi ; FCC ID: VDQ828-02

Communication System: UID 0, GPRS 850 (1Down, 4Up) (0); Frequency: 836.6 MHz; Duty Cycle: 1:2

Medium parameters used: $f = 837 \text{ MHz}$; $\sigma = 0.971 \text{ S/m}$; $\epsilon_r = 54.339$; $\rho = 1000 \text{ kg/m}^3$

Phantom section: Flat Section

Measurement Standard: DASYS5 (IEEE/IEC/ANSI C63.19-2011)

DASY5.2 Configuration:

- Area Scan setting - Find Secondary Maximum Within: 2.0dB and with a peak SAR value greater than 0.5 W/Kg
- Probe: EX3DV4 - SN3977; ConvF(9.82, 9.82, 9.82); Calibrated: 2016/3/9;
- Sensor-Surface: 2mm (Mechanical Surface Detection)
- Electronics: DAE4 Sn779; Calibrated: 2016/3/2
- Phantom: ELI v4.0; Type: QDOVA001BB; Serial: TP:1036
- Measurement SW: DASYS52, Version 52.8 (8); SEMCAD X Version 14.6.10 (7331)

Flat/Area Scan (81x91x1):

Interpolated grid: $dx=1.500 \text{ mm}$, $dy=1.500 \text{ mm}$

Maximum value of SAR (interpolated) = 0.443 W/kg

Flat/Zoom Scan (5x5x7)/Cube 0:

Measurement grid: $dx=8\text{mm}$, $dy=8\text{mm}$, $dz=5\text{mm}$

Reference Value = 19.48 V/m; Power Drift = -0.15 dB

Peak SAR (extrapolated) = 0.446 W/kg

SAR(1 g) = 0.272 W/kg; SAR(10 g) = 0.183 W/kg

Maximum value of SAR (measured) = 0.402 W/kg

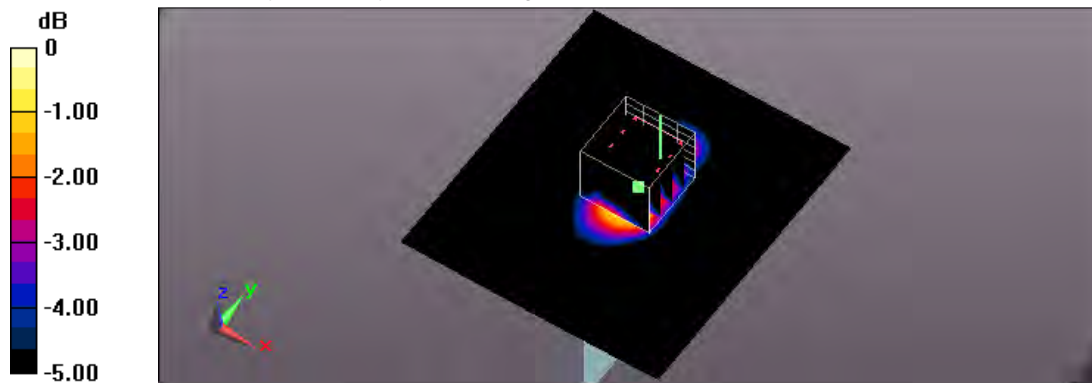

0 dB = 0.402 W/kg = -3.96 dBW/kg

Test Laboratory: A Test Lab Techno Corp.

Date/Time: 2016/11/23 AM 03:53:29

5_GPRS 850 CH190_1D4U_Side6_5mm

DUT: BR828PGTW ; Type: POCSAG ALPHANUMERIC PAGER with 3G/GSM, GPS & Wi-Fi ; FCC ID: VDQ828-02

Communication System: UID 0, GPRS 850 (1Down, 4Up) (0); Frequency: 836.6 MHz; Duty Cycle: 1:2

Medium parameters used: $f = 837 \text{ MHz}$; $\sigma = 0.971 \text{ S/m}$; $\epsilon_r = 54.339$; $\rho = 1000 \text{ kg/m}^3$

Phantom section: Flat Section

Measurement Standard: DASYS5 (IEEE/IEC/ANSI C63.19-2011)

DASY5.2 Configuration:

- Area Scan setting - Find Secondary Maximum Within: 2.0dB and with a peak SAR value greater than 0.5 W/Kg
- Probe: EX3DV4 - SN3977; ConvF(9.82, 9.82, 9.82); Calibrated: 2016/3/9;
- Sensor-Surface: 2mm (Mechanical Surface Detection)
- Electronics: DAE4 Sn779; Calibrated: 2016/3/2
- Phantom: ELI v4.0; Type: QDOVA001BB; Serial: TP:1036
- Measurement SW: DASYS52, Version 52.8 (8); SEMCAD X Version 14.6.10 (7331)

Flat/Area Scan (81x91x1):

Interpolated grid: $dx=1.500 \text{ mm}$, $dy=1.500 \text{ mm}$

Maximum value of SAR (interpolated) = 0.142 W/kg

Flat/Zoom Scan (5x5x7)/Cube 0:

Measurement grid: $dx=8\text{mm}$, $dy=8\text{mm}$, $dz=5\text{mm}$

Reference Value = 8.226 V/m; Power Drift = -0.18 dB

Peak SAR (extrapolated) = 0.189 W/kg

SAR(1 g) = 0.121 W/kg; SAR(10 g) = 0.078 W/kg

Maximum value of SAR (measured) = 0.160 W/kg

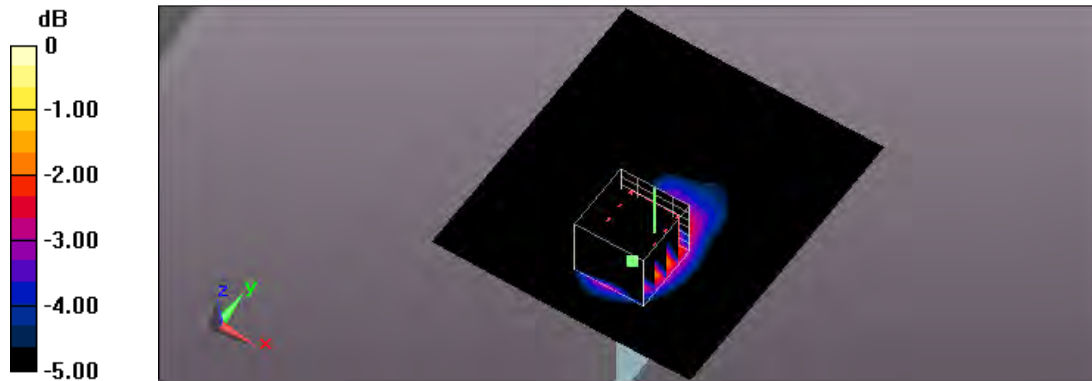

0 dB = 0.160 W/kg = -7.96 dBW/kg

Test Laboratory: A Test Lab Techno Corp.

Date/Time: 2016/12/5 PM 05:36:56

25_GPRS 850 CH190_1D4U_Side2_with holder_0mm

DUT: BR828PGTW ; Type: POCSAG ALPHANUMERIC PAGER with 3G/GSM, GPS & Wi-Fi ; FCC ID: VDQ828-02

Communication System: UID 0, GPRS 850 (1Down, 4Up) (0); Frequency: 836.6 MHz; Duty Cycle: 1:2

Medium parameters used: $f = 837 \text{ MHz}$; $\sigma = 0.971 \text{ S/m}$; $\epsilon_r = 54.339$; $\rho = 1000 \text{ kg/m}^3$

Phantom section: Flat Section

Measurement Standard: DASYS5 (IEEE/IEC/ANSI C63.19-2011)

DASY5.2 Configuration:

- Area Scan setting - Find Secondary Maximum Within: 2.0dB and with a peak SAR value greater than 0.5 W/Kg
- Probe: EX3DV4 - SN3977; ConvF(9.82, 9.82, 9.82); Calibrated: 2016/3/9;
- Sensor-Surface: 2mm (Mechanical Surface Detection)
- Electronics: DAE4 Sn779; Calibrated: 2016/3/2
- Phantom: ELI v4.0; Type: QDOVA001BB; Serial: TP:1036
- Measurement SW: DASYS52, Version 52.8 (8); SEMCAD X Version 14.6.10 (7331)

Flat/Area Scan (81x91x1):

Interpolated grid: $dx=1.500 \text{ mm}$, $dy=1.500 \text{ mm}$

Maximum value of SAR (interpolated) = 0.672 W/kg

Flat/Zoom Scan (5x5x7)/Cube 0:

Measurement grid: $dx=8\text{mm}$, $dy=8\text{mm}$, $dz=5\text{mm}$

Reference Value = 26.26 V/m; Power Drift = -0.17 dB

Peak SAR (extrapolated) = 0.802 W/kg

SAR(1 g) = 0.480 W/kg; SAR(10 g) = 0.334 W/kg

Maximum value of SAR (measured) = 0.636 W/kg

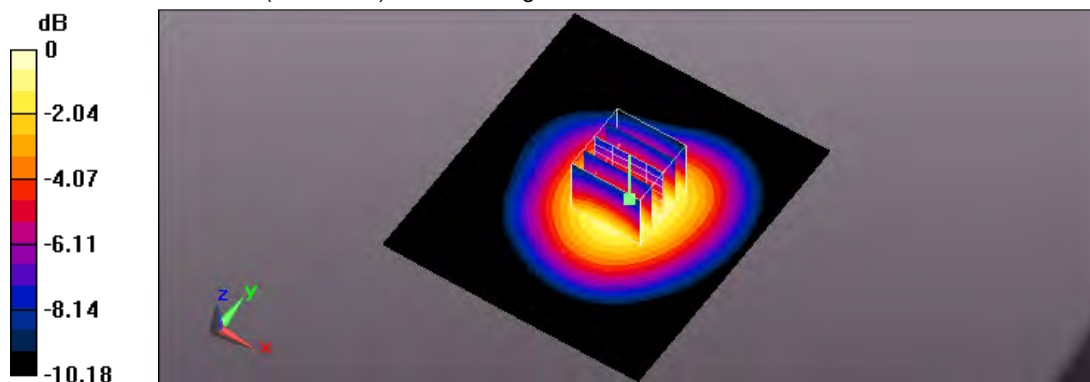

0 dB = 0.808 W/kg = -0.93 dBW/kg

Test Laboratory: A Test Lab Techno Corp.

Date/Time: 2016/11/23 PM 05:18:32

11_GPRS 1900 CH661_1D4U_Side1_5mm

DUT: BR828PGTW ; Type: POCSAG ALPHANUMERIC PAGER with 3G/GSM, GPS & Wi-Fi ; FCC ID: VDQ828-02

Communication System: UID 0, GPRS PCS (1Down,4Up) (0); Frequency: 1880 MHz;Duty Cycle: 1:2

Medium parameters used: $f = 1880$ MHz; $\sigma = 1.564$ S/m; $\epsilon_r = 52.223$; $\rho = 1000$ kg/m³

Phantom section: Flat Section

Measurement Standard: DASYS5 (IEEE/IEC/ANSI C63.19-2011)

DASY5.2 Configuration:

- Area Scan setting - Find Secondary Maximum Within:2.0dB and with a peak SAR value greater than 0.5 W/Kg
- Probe: EX3DV4 - SN3977; ConvF(7.66, 7.66, 7.66); Calibrated: 2016/3/9;
- Sensor-Surface: 2mm (Mechanical Surface Detection)
- Electronics: DAE4 Sn779; Calibrated: 2016/3/2
- Phantom: ELI v4.0; Type: QDOVA001BB; Serial: TP:1036
- Measurement SW: DASYS52, Version 52.8 (8); SEMCAD X Version 14.6.10 (7331)

Flat/Area Scan (81x91x1):

Interpolated grid: dx=1.500 mm, dy=1.500 mm

Maximum value of SAR (interpolated) = 0.125 W/kg

Flat/Zoom Scan (5x5x7)/Cube 0:

Measurement grid: dx=8mm, dy=8mm, dz=5mm

Reference Value = 3.462 V/m; Power Drift = -0.12 dB

Peak SAR (extrapolated) = 0.147 W/kg

SAR(1 g) = 0.091 W/kg; SAR(10 g) = 0.052 W/kg

Maximum value of SAR (measured) = 0.117 W/kg

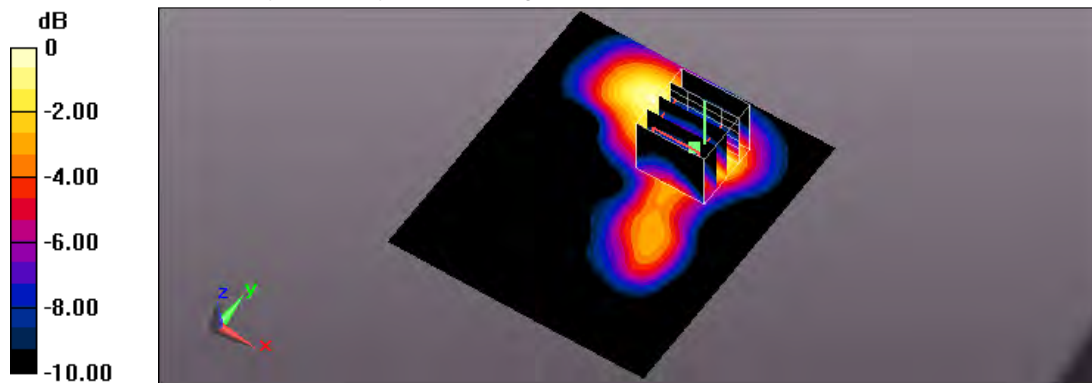

0 dB = 0.117 W/kg = -9.32 dBW/kg

Test Laboratory: A Test Lab Techno Corp.

Date/Time: 2016/11/23 PM 05:37:11

12_GPRS 1900 CH661_1D4U_Side2_5mm

DUT: BR828PGTW ; Type: POCSAG ALPHANUMERIC PAGER with 3G/GSM, GPS & Wi-Fi ; FCC ID: VDQ828-02

Communication System: UID 0, GPRS PCS (1Down,4Up) (0); Frequency: 1880 MHz;Duty Cycle: 1:2

Medium parameters used: $f = 1880$ MHz; $\sigma = 1.564$ S/m; $\epsilon_r = 52.223$; $\rho = 1000$ kg/m³

Phantom section: Flat Section

Measurement Standard: DASYS5 (IEEE/IEC/ANSI C63.19-2011)

DASY5.2 Configuration:

- Area Scan setting - Find Secondary Maximum Within:2.0dB and with a peak SAR value greater than 0.5 W/Kg
- Probe: EX3DV4 - SN3977; ConvF(7.66, 7.66, 7.66); Calibrated: 2016/3/9;
- Sensor-Surface: 2mm (Mechanical Surface Detection)
- Electronics: DAE4 Sn779; Calibrated: 2016/3/2
- Phantom: ELI v4.0; Type: QDOVA001BB; Serial: TP:1036
- Measurement SW: DASYS52, Version 52.8 (8); SEMCAD X Version 14.6.10 (7331)

Flat/Area Scan (81x91x1):

Interpolated grid: dx=1.500 mm, dy=1.500 mm

Maximum value of SAR (interpolated) = 0.796 W/kg

Flat/Zoom Scan (5x5x7)/Cube 0:

Measurement grid: dx=8mm, dy=8mm, dz=5mm

Reference Value = 3.962 V/m; Power Drift = -0.14 dB

Peak SAR (extrapolated) = 0.925 W/kg

SAR(1 g) = 0.492 W/kg; SAR(10 g) = 0.241 W/kg

Maximum value of SAR (measured) = 0.733 W/kg

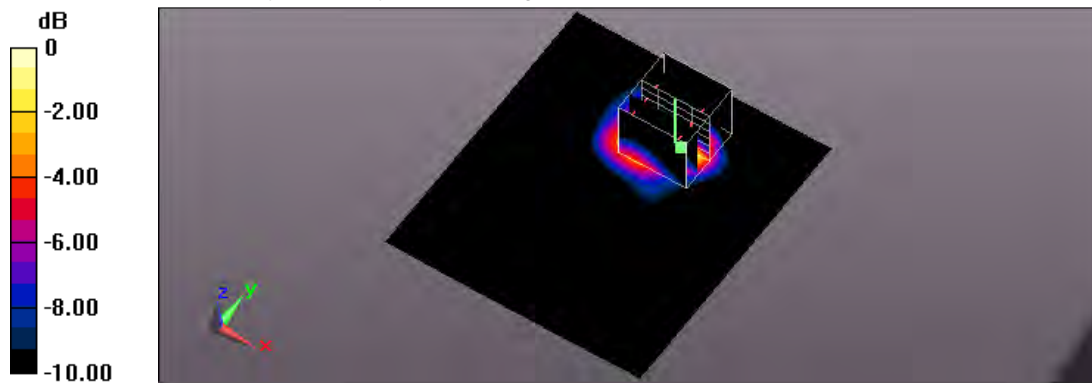

0 dB = 0.733 W/kg = -1.35 dBW/kg

Test Laboratory: A Test Lab Techno Corp.

Date/Time: 2016/11/23 PM 02:09:58

13_GPRS 1900 CH661_1D4U_Side3_5mm

DUT: BR828PGTW ; Type: POCSAG ALPHANUMERIC PAGER with 3G/GSM, GPS & Wi-Fi ; FCC ID: VDQ828-02

Communication System: UID 0, GPRS PCS (1Down,4Up) (0); Frequency: 1880 MHz;Duty Cycle: 1:2

Medium parameters used: $f = 1880$ MHz; $\sigma = 1.564$ S/m; $\epsilon_r = 52.223$; $\rho = 1000$ kg/m³

Phantom section: Flat Section

Measurement Standard: DASYS5 (IEEE/IEC/ANSI C63.19-2011)

DASY5.2 Configuration:

- Area Scan setting - Find Secondary Maximum Within:2.0dB and with a peak SAR value greater than 0.5 W/Kg
- Probe: EX3DV4 - SN3977; ConvF(7.66, 7.66, 7.66); Calibrated: 2016/3/9;
- Sensor-Surface: 2mm (Mechanical Surface Detection)
- Electronics: DAE4 Sn779; Calibrated: 2016/3/2
- Phantom: ELI v4.0; Type: QDOVA001BB; Serial: TP:1036
- Measurement SW: DASYS52, Version 52.8 (8); SEMCAD X Version 14.6.10 (7331)

Flat/Area Scan (81x91x1):

Interpolated grid: dx=1.500 mm, dy=1.500 mm

Maximum value of SAR (interpolated) = 0.723 W/kg

Flat/Zoom Scan (5x5x7)/Cube 0:

Measurement grid: dx=8mm, dy=8mm, dz=5mm

Reference Value = 10.52 V/m; Power Drift = 0.11 dB

Peak SAR (extrapolated) = 0.971 W/kg

SAR(1 g) = 0.493 W/kg; SAR(10 g) = 0.235 W/kg

Maximum value of SAR (measured) = 0.652 W/kg

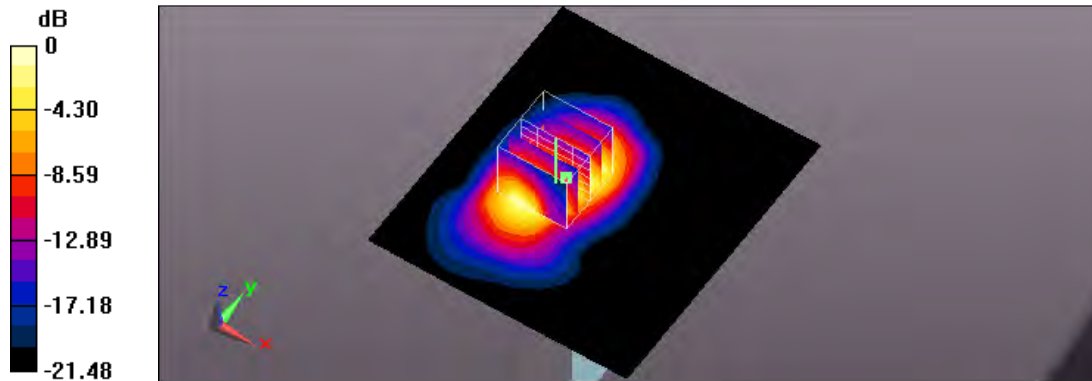

0 dB = 0.652 W/kg = -1.86 dBW/kg

Test Laboratory: A Test Lab Techno Corp.

Date/Time: 2016/11/23 PM 06:16:09

14_GPRS 1900 CH661_1D4U_Side5_5mm

DUT: BR828PGTW ; Type: POCSAG ALPHANUMERIC PAGER with 3G/GSM, GPS & Wi-Fi ; FCC ID: VDQ828-02

Communication System: UID 0, GPRS PCS (1Down,4Up) (0); Frequency: 1880 MHz;Duty Cycle: 1:2

Medium parameters used: $f = 1880$ MHz; $\sigma = 1.564$ S/m; $\epsilon_r = 52.223$; $\rho = 1000$ kg/m³

Phantom section: Flat Section

Measurement Standard: DASYS5 (IEEE/IEC/ANSI C63.19-2011)

DASY5.2 Configuration:

- Area Scan setting - Find Secondary Maximum Within:2.0dB and with a peak SAR value greater than 0.5 W/Kg
- Probe: EX3DV4 - SN3977; ConvF(7.66, 7.66, 7.66); Calibrated: 2016/3/9;
- Sensor-Surface: 2mm (Mechanical Surface Detection)
- Electronics: DAE4 Sn779; Calibrated: 2016/3/2
- Phantom: ELI v4.0; Type: QDOVA001BB; Serial: TP:1036
- Measurement SW: DASYS52, Version 52.8 (8); SEMCAD X Version 14.6.10 (7331)

Flat/Area Scan (81x91x1):

Interpolated grid: dx=1.500 mm, dy=1.500 mm

Maximum value of SAR (interpolated) = 0.107 W/kg

Flat/Zoom Scan (5x5x7)/Cube 0:

Measurement grid: dx=8mm, dy=8mm, dz=5mm

Reference Value = 8.606 V/m; Power Drift = -0.18 dB

Peak SAR (extrapolated) = 0.121 W/kg

SAR(1 g) = 0.076 W/kg; SAR(10 g) = 0.045 W/kg

Maximum value of SAR (measured) = 0.0992 W/kg

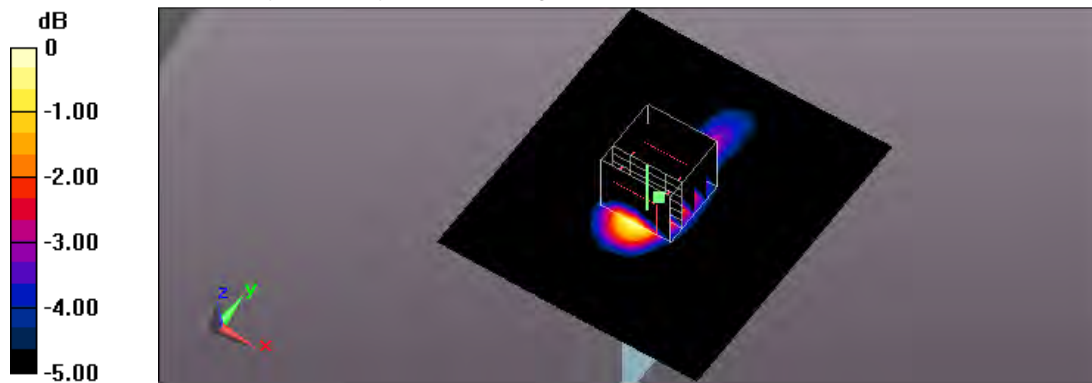

0 dB = 0.0992 W/kg = -10.03 dBW/kg

Test Laboratory: A Test Lab Techno Corp.

Date/Time: 2016/11/23 PM 06:40:18

15_GPRS 1900 CH661_1D4U_Side6_5mm

DUT: BR828PGTW ; Type: POCSAG ALPHANUMERIC PAGER with 3G/GSM, GPS & Wi-Fi ; FCC ID: VDQ828-02

Communication System: UID 0, GPRS PCS (1Down,4Up) (0); Frequency: 1880 MHz;Duty Cycle: 1:2

Medium parameters used: $f = 1880$ MHz; $\sigma = 1.564$ S/m; $\epsilon_r = 52.223$; $\rho = 1000$ kg/m³

Phantom section: Flat Section

Measurement Standard: DASYS5 (IEEE/IEC/ANSI C63.19-2011)

DASY5.2 Configuration:

- Area Scan setting - Find Secondary Maximum Within:2.0dB and with a peak SAR value greater than 0.5 W/Kg
- Probe: EX3DV4 - SN3977; ConvF(7.66, 7.66, 7.66); Calibrated: 2016/3/9;
- Sensor-Surface: 2mm (Mechanical Surface Detection)
- Electronics: DAE4 Sn779; Calibrated: 2016/3/2
- Phantom: ELI v4.0; Type: QDOVA001BB; Serial: TP:1036
- Measurement SW: DASYS52, Version 52.8 (8); SEMCAD X Version 14.6.10 (7331)

Flat/Area Scan (81x91x1):

Interpolated grid: dx=1.500 mm, dy=1.500 mm

Maximum value of SAR (interpolated) = 0.137 W/kg

Flat/Zoom Scan (5x5x7)/Cube 0:

Measurement grid: dx=8mm, dy=8mm, dz=5mm

Reference Value = 6.856 V/m; Power Drift = -0.14 dB

Peak SAR (extrapolated) = 0.166 W/kg

SAR(1 g) = 0.099 W/kg; SAR(10 g) = 0.054 W/kg

Maximum value of SAR (measured) = 0.136 W/kg

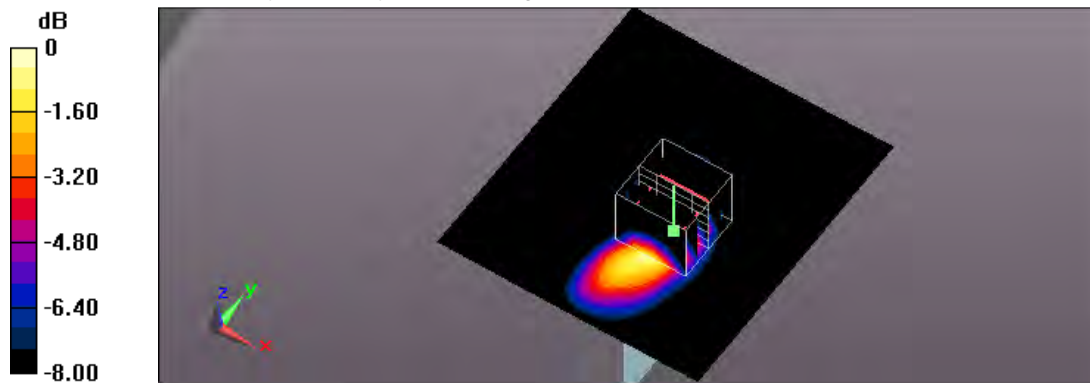

0 dB = 0.136 W/kg = -8.66 dBW/kg

Test Laboratory: A Test Lab Techno Corp.

Date/Time: 2016/12/5 PM 07:35:24

26_GPRS 1900 CH661_1D4U_Side2_with holder_0mm

DUT: BR828PGTW ; Type: POCSAG ALPHANUMERIC PAGER with 3G/GSM, GPS & Wi-Fi ; FCC ID: VDQ828-02

Communication System: UID 0, GPRS PCS (1Down,4Up) (0); Frequency: 1880 MHz;Duty Cycle: 1:2

Medium parameters used: $f = 1880$ MHz; $\sigma = 1.564$ S/m; $\epsilon_r = 52.223$; $\rho = 1000$ kg/m³

Phantom section: Flat Section

Measurement Standard: DASYS5 (IEEE/IEC/ANSI C63.19-2011)

DASY5.2 Configuration:

- Area Scan setting - Find Secondary Maximum Within:2.0dB and with a peak SAR value greater than 0.5 W/Kg
- Probe: EX3DV4 - SN3977; ConvF(7.66, 7.66, 7.66); Calibrated: 2016/3/9;
- Sensor-Surface: 2mm (Mechanical Surface Detection)
- Electronics: DAE4 Sn779; Calibrated: 2016/3/2
- Phantom: ELI v4.0; Type: QDOVA001BB; Serial: TP:1036
- Measurement SW: DASYS52, Version 52.8 (8); SEMCAD X Version 14.6.10 (7331)

Flat/Area Scan (81x91x1):

Interpolated grid: dx=1.500 mm, dy=1.500 mm

Maximum value of SAR (interpolated) = 0.213 W/kg

Flat/Zoom Scan (5x5x7)/Cube 0:

Measurement grid: dx=8mm, dy=8mm, dz=5mm

Reference Value = 3.956 V/m; Power Drift = -0.17 dB

Peak SAR (extrapolated) = 0.237 W/kg

SAR(1 g) = 0.143 W/kg; SAR(10 g) = 0.078 W/kg

Maximum value of SAR (measured) = 0.193 W/kg

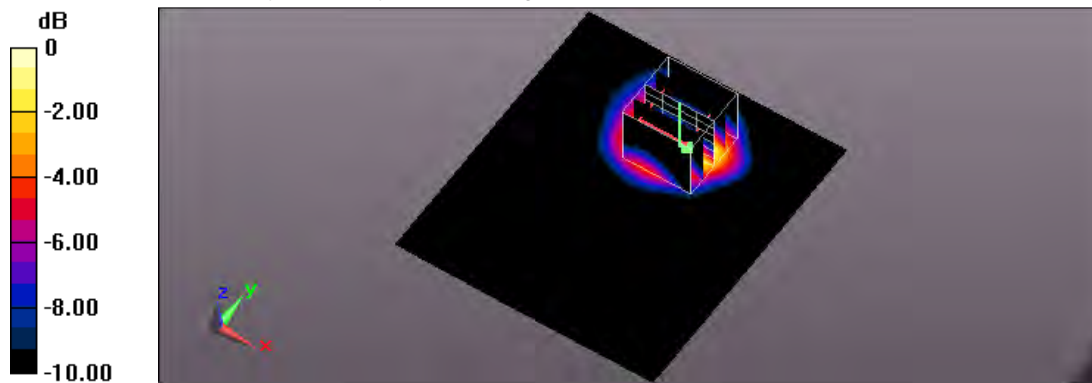

0 dB = 0.193 W/kg = -7.14 dBW/kg

Test Laboratory: A Test Lab Techno Corp.

Date/Time: 2016/11/23 PM 03:07:37

16_WCDMA Band II CH9400_Side1_5mm

DUT: BR828PGTW ; Type: POCSAG ALPHANUMERIC PAGER with 3G/GSM, GPS & Wi-Fi ; FCC ID: VDQ828-02

Communication System: UID 0, WCDMA Band II (0); Frequency: 1880 MHz;Duty Cycle: 1:1

Medium parameters used: $f = 1880$ MHz; $\sigma = 1.564$ S/m; $\epsilon_r = 52.223$; $\rho = 1000$ kg/m³

Phantom section: Flat Section

Measurement Standard: DASYS5 (IEEE/IEC/ANSI C63.19-2011)

DASY5.2 Configuration:

- Area Scan setting - Find Secondary Maximum Within:2.0dB and with a peak SAR value greater than 0.5 W/Kg
- Probe: EX3DV4 - SN3977; ConvF(7.66, 7.66, 7.66); Calibrated: 2016/3/9;
- Sensor-Surface: 2mm (Mechanical Surface Detection)
- Electronics: DAE4 Sn779; Calibrated: 2016/3/2
- Phantom: ELI v4.0; Type: QDOVA001BB; Serial: TP:1036
- Measurement SW: DASYS52, Version 52.8 (8); SEMCAD X Version 14.6.10 (7331)

Flat/Area Scan (81x91x1):

Interpolated grid: dx=1.500 mm, dy=1.500 mm

Maximum value of SAR (interpolated) = 0.0762 W/kg

Flat/Zoom Scan (5x5x7)/Cube 0:

Measurement grid: dx=8mm, dy=8mm, dz=5mm

Reference Value = 2.459 V/m; Power Drift = -0.10 dB

Peak SAR (extrapolated) = 0.0900 W/kg

SAR(1 g) = 0.055 W/kg; SAR(10 g) = 0.032 W/kg

Maximum value of SAR (measured) = 0.0717 W/kg

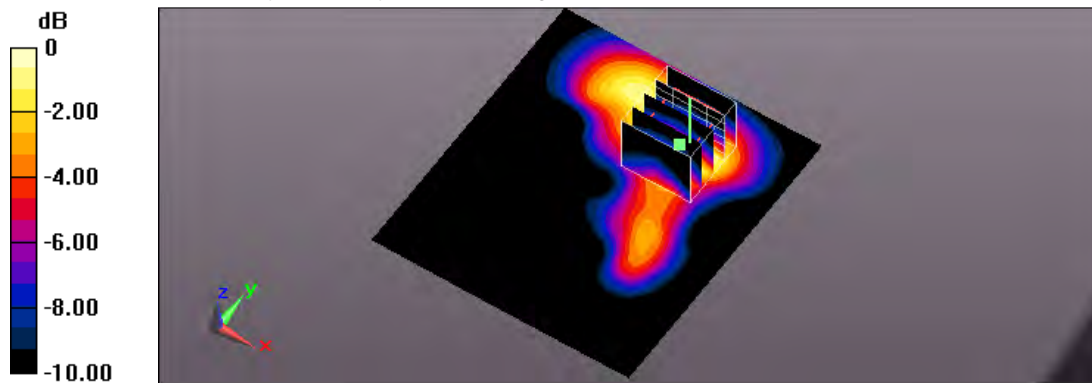

0 dB = 0.0717 W/kg = -11.44 dBW/kg

Test Laboratory: A Test Lab Techno Corp.

Date/Time: 2016/11/23 PM 03:27:01

17_WCDMA Band II CH9400_Side2_5mm

DUT: BR828PGTW ; Type: POCSAG ALPHANUMERIC PAGER with 3G/GSM, GPS & Wi-Fi ; FCC ID: VDQ828-02

Communication System: UID 0, WCDMA Band II (0); Frequency: 1880 MHz;Duty Cycle: 1:1

Medium parameters used: $f = 1880$ MHz; $\sigma = 1.564$ S/m; $\epsilon_r = 52.223$; $\rho = 1000$ kg/m³

Phantom section: Flat Section

Measurement Standard: DASYS5 (IEEE/IEC/ANSI C63.19-2011)

DASY5.2 Configuration:

- Area Scan setting - Find Secondary Maximum Within:2.0dB and with a peak SAR value greater than 0.5 W/Kg
- Probe: EX3DV4 - SN3977; ConvF(7.66, 7.66, 7.66); Calibrated: 2016/3/9;
- Sensor-Surface: 2mm (Mechanical Surface Detection)
- Electronics: DAE4 Sn779; Calibrated: 2016/3/2
- Phantom: ELI v4.0; Type: QDOVA001BB; Serial: TP:1036
- Measurement SW: DASYS52, Version 52.8 (8); SEMCAD X Version 14.6.10 (7331)

Flat/Area Scan (81x91x1):

Interpolated grid: dx=1.500 mm, dy=1.500 mm

Maximum value of SAR (interpolated) = 0.514 W/kg

Flat/Zoom Scan (5x5x7)/Cube 0:

Measurement grid: dx=8mm, dy=8mm, dz=5mm

Reference Value = 2.856 V/m; Power Drift = -0.17 dB

Peak SAR (extrapolated) = 0.600 W/kg

SAR(1 g) = 0.318 W/kg; SAR(10 g) = 0.154 W/kg

Maximum value of SAR (measured) = 0.459 W/kg

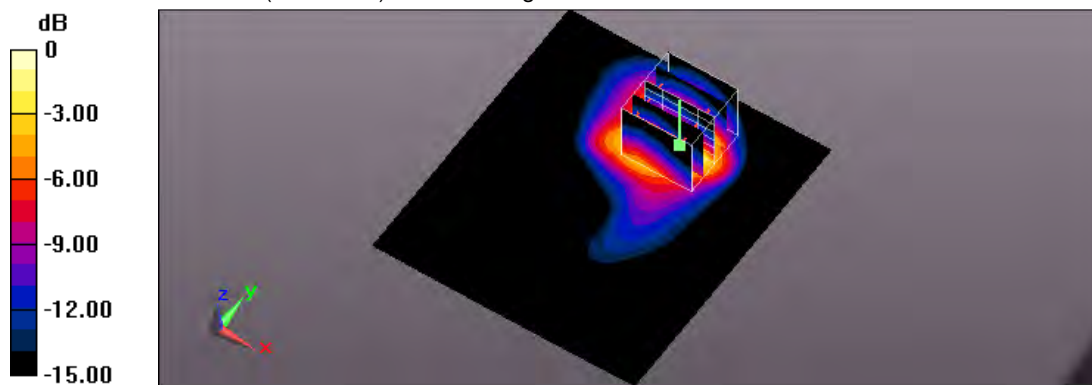

0 dB = 0.459 W/kg = -3.38 dBW/kg

Test Laboratory: A Test Lab Techno Corp.

Date/Time: 2016/11/23 PM 02:45:54

18_WCDMA Band II CH9400_Side3_5mm

DUT: BR828PGTW ; Type: POCSAG ALPHANUMERIC PAGER with 3G/GSM, GPS & Wi-Fi ; FCC ID: VDQ828-02

Communication System: UID 0, WCDMA Band II (0); Frequency: 1880 MHz;Duty Cycle: 1:1

Medium parameters used: $f = 1880$ MHz; $\sigma = 1.564$ S/m; $\epsilon_r = 52.223$; $\rho = 1000$ kg/m³

Phantom section: Flat Section

Measurement Standard: DASYS5 (IEEE/IEC/ANSI C63.19-2011)

DASY5.2 Configuration:

- Area Scan setting - Find Secondary Maximum Within:2.0dB and with a peak SAR value greater than 0.5 W/Kg
- Probe: EX3DV4 - SN3977; ConvF(7.66, 7.66, 7.66); Calibrated: 2016/3/9;
- Sensor-Surface: 2mm (Mechanical Surface Detection)
- Electronics: DAE4 Sn779; Calibrated: 2016/3/2
- Phantom: ELI v4.0; Type: QDOVA001BB; Serial: TP:1036
- Measurement SW: DASYS52, Version 52.8 (8); SEMCAD X Version 14.6.10 (7331)

Flat/Area Scan (81x91x1):

Interpolated grid: dx=1.500 mm, dy=1.500 mm

Maximum value of SAR (interpolated) = 0.627 W/kg

Flat/Zoom Scan (5x5x7)/Cube 0:

Measurement grid: dx=8mm, dy=8mm, dz=5mm

Reference Value = 9.663 V/m; Power Drift = 0.06 dB

Peak SAR (extrapolated) = 0.754 W/kg

SAR(1 g) = 0.383 W/kg; SAR(10 g) = 0.186 W/kg

Maximum value of SAR (measured) = 0.533 W/kg

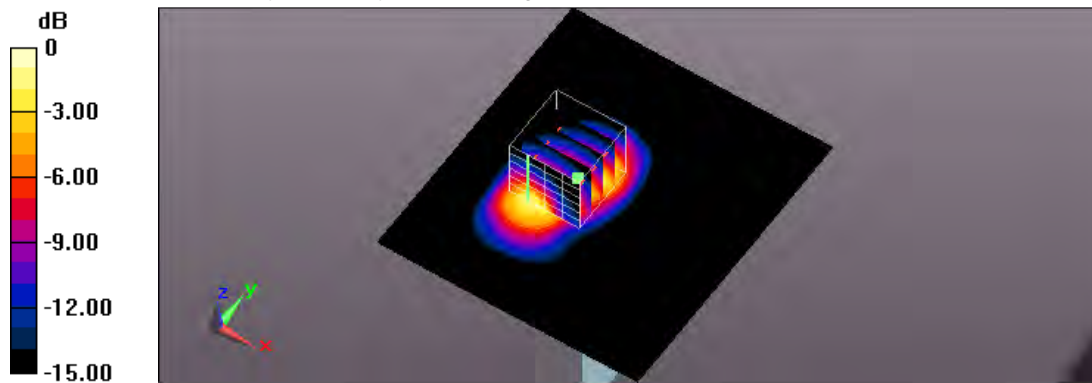

0 dB = 0.533 W/kg = -2.73 dBW/kg

Test Laboratory: A Test Lab Techno Corp.

Date/Time: 2016/11/23 PM 03:57:58

19_WCDMA Band II CH9400_Side5_5mm

DUT: BR828PGTW ; Type: POCSAG ALPHANUMERIC PAGER with 3G/GSM, GPS & Wi-Fi ; FCC ID: VDQ828-02

Communication System: UID 0, WCDMA Band II (0); Frequency: 1880 MHz;Duty Cycle: 1:1

Medium parameters used: $f = 1880$ MHz; $\sigma = 1.564$ S/m; $\epsilon_r = 52.223$; $\rho = 1000$ kg/m³

Phantom section: Flat Section

Measurement Standard: DASYS5 (IEEE/IEC/ANSI C63.19-2011)

DASY5.2 Configuration:

- Area Scan setting - Find Secondary Maximum Within:2.0dB and with a peak SAR value greater than 0.5 W/Kg
- Probe: EX3DV4 - SN3977; ConvF(7.66, 7.66, 7.66); Calibrated: 2016/3/9;
- Sensor-Surface: 2mm (Mechanical Surface Detection)
- Electronics: DAE4 Sn779; Calibrated: 2016/3/2
- Phantom: ELI v4.0; Type: QDOVA001BB; Serial: TP:1036
- Measurement SW: DASYS52, Version 52.8 (8); SEMCAD X Version 14.6.10 (7331)

Flat/Area Scan (81x91x1):

Interpolated grid: dx=1.500 mm, dy=1.500 mm

Maximum value of SAR (interpolated) = 0.0838 W/kg

Flat/Zoom Scan (5x5x7)/Cube 0:

Measurement grid: dx=8mm, dy=8mm, dz=5mm

Reference Value = 7.363 V/m; Power Drift = 0.12 dB

Peak SAR (extrapolated) = 0.0960 W/kg

SAR(1 g) = 0.060 W/kg; SAR(10 g) = 0.035 W/kg

Maximum value of SAR (measured) = 0.0793 W/kg

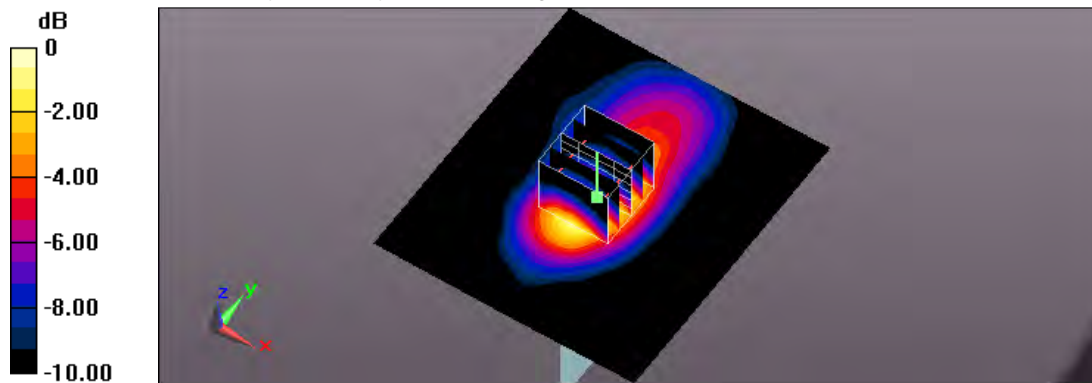

0 dB = 0.0793 W/kg = -11.01 dBW/kg

Test Laboratory: A Test Lab Techno Corp.

Date/Time: 2016/11/23 PM 04:16:58

20_WCDMA Band II CH9400_Side6_5mm

DUT: BR828PGTW ; Type: POCSAG ALPHANUMERIC PAGER with 3G/GSM, GPS & Wi-Fi ; FCC ID: VDQ828-02

Communication System: UID 0, WCDMA Band II (0); Frequency: 1880 MHz;Duty Cycle: 1:1

Medium parameters used: $f = 1880$ MHz; $\sigma = 1.564$ S/m; $\epsilon_r = 52.223$; $\rho = 1000$ kg/m³

Phantom section: Flat Section

Measurement Standard: DASYS5 (IEEE/IEC/ANSI C63.19-2011)

DASY5.2 Configuration:

- Area Scan setting - Find Secondary Maximum Within:2.0dB and with a peak SAR value greater than 0.5 W/Kg
- Probe: EX3DV4 - SN3977; ConvF(7.66, 7.66, 7.66); Calibrated: 2016/3/9;
- Sensor-Surface: 2mm (Mechanical Surface Detection)
- Electronics: DAE4 Sn779; Calibrated: 2016/3/2
- Phantom: ELI v4.0; Type: QDOVA001BB; Serial: TP:1036
- Measurement SW: DASYS52, Version 52.8 (8); SEMCAD X Version 14.6.10 (7331)

Flat/Area Scan (81x91x1):

Interpolated grid: dx=1.500 mm, dy=1.500 mm

Maximum value of SAR (interpolated) = 0.0750 W/kg

Flat/Zoom Scan (5x5x7)/Cube 0:

Measurement grid: dx=8mm, dy=8mm, dz=5mm

Reference Value = 5.333 V/m; Power Drift = -0.17 dB

Peak SAR (extrapolated) = 0.0900 W/kg

SAR(1 g) = 0.054 W/kg; SAR(10 g) = 0.030 W/kg

Maximum value of SAR (measured) = 0.0745 W/kg

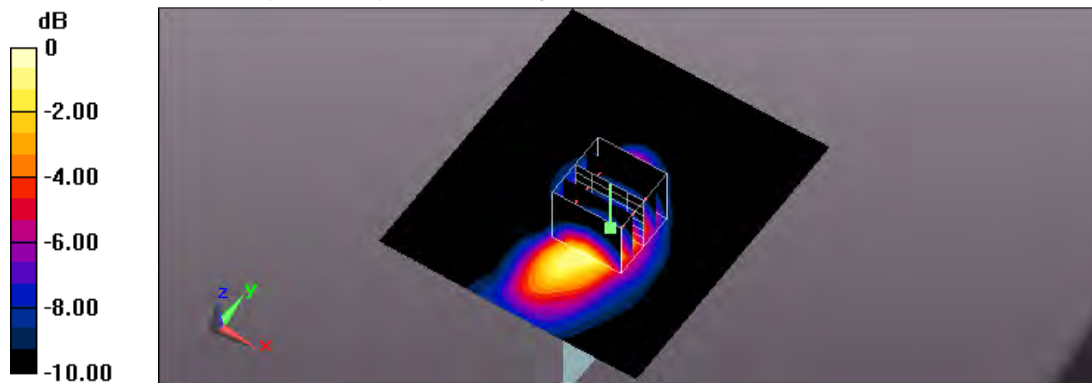

0 dB = 0.0745 W/kg = -11.28 dBW/kg

Test Laboratory: A Test Lab Techno Corp.

Date/Time: 2016/11/23 AM 09:32:24

6_WCDMA Band V CH4183_Side1_5mm

DUT: BR828PGTW ; Type: POCSAG ALPHANUMERIC PAGER with 3G/GSM, GPS & Wi-Fi ; FCC ID: VDQ828-02

Communication System: UID 0, WCDMA Band V (0); Frequency: 836.6 MHz; Duty Cycle: 1:1

Medium parameters used: $f = 837 \text{ MHz}$; $\sigma = 0.971 \text{ S/m}$; $\epsilon_r = 54.339$; $\rho = 1000 \text{ kg/m}^3$

Phantom section: Flat Section

Measurement Standard: DASYS5 (IEEE/IEC/ANSI C63.19-2011)

DASY5.2 Configuration:

- Area Scan setting - Find Secondary Maximum Within: 2.0dB and with a peak SAR value greater than 0.5 W/Kg
- Probe: EX3DV4 - SN3977; ConvF(9.82, 9.82, 9.82); Calibrated: 2016/3/9;
- Sensor-Surface: 2mm (Mechanical Surface Detection)
- Electronics: DAE4 Sn779; Calibrated: 2016/3/2
- Phantom: ELI v4.0; Type: QDOVA001BB; Serial: TP:1036
- Measurement SW: DASYS52, Version 52.8 (8); SEMCAD X Version 14.6.10 (7331)

Flat/Area Scan (81x91x1):

Interpolated grid: $dx=1.500 \text{ mm}$, $dy=1.500 \text{ mm}$

Maximum value of SAR (interpolated) = 0.214 W/kg

Flat/Zoom Scan (5x5x7)/Cube 0:

Measurement grid: $dx=8\text{mm}$, $dy=8\text{mm}$, $dz=5\text{mm}$

Reference Value = 10.03 V/m; Power Drift = 0.05 dB

Peak SAR (extrapolated) = 0.270 W/kg

SAR(1 g) = 0.169 W/kg; SAR(10 g) = 0.108 W/kg

Maximum value of SAR (measured) = 0.215 W/kg

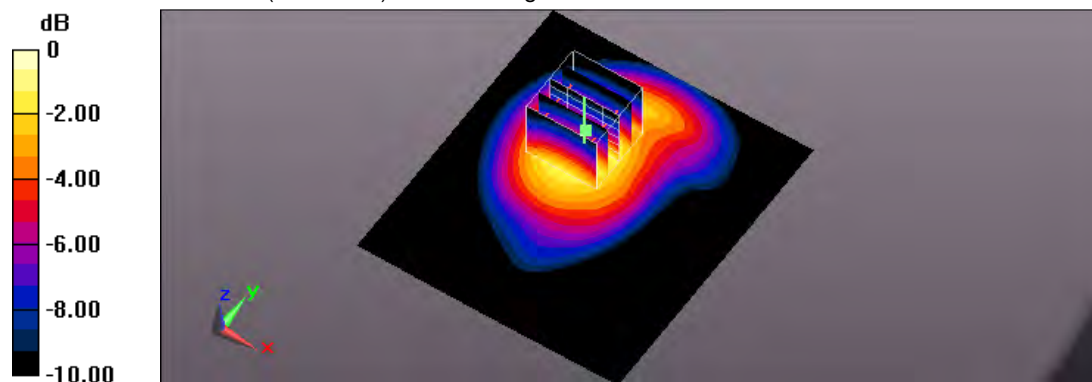

0 dB = 0.215 W/kg = -6.68 dBW/kg

Test Laboratory: A Test Lab Techno Corp.

Date/Time: 2016/11/23 AM 10:09:48

7_WCDMA Band V CH4183_Side2_5mm

DUT: BR828PGTW ; Type: POCSAG ALPHANUMERIC PAGER with 3G/GSM, GPS & Wi-Fi ; FCC ID: VDQ828-02

Communication System: UID 0, WCDMA Band V (0); Frequency: 836.6 MHz; Duty Cycle: 1:1

Medium parameters used: $f = 837 \text{ MHz}$; $\sigma = 0.971 \text{ S/m}$; $\epsilon_r = 54.339$; $\rho = 1000 \text{ kg/m}^3$

Phantom section: Flat Section

Measurement Standard: DASYS5 (IEEE/IEC/ANSI C63.19-2011)

DASY5.2 Configuration:

- Area Scan setting - Find Secondary Maximum Within: 2.0dB and with a peak SAR value greater than 0.5 W/Kg
- Probe: EX3DV4 - SN3977; ConvF(9.82, 9.82, 9.82); Calibrated: 2016/3/9;
- Sensor-Surface: 2mm (Mechanical Surface Detection)
- Electronics: DAE4 Sn779; Calibrated: 2016/3/2
- Phantom: ELI v4.0; Type: QDOVA001BB; Serial: TP:1036
- Measurement SW: DASYS52, Version 52.8 (8); SEMCAD X Version 14.6.10 (7331)

Flat/Area Scan (81x91x1):

Interpolated grid: $dx=1.500 \text{ mm}$, $dy=1.500 \text{ mm}$

Maximum value of SAR (interpolated) = 0.445 W/kg

Flat/Zoom Scan (5x5x7)/Cube 0:

Measurement grid: $dx=8\text{mm}$, $dy=8\text{mm}$, $dz=5\text{mm}$

Reference Value = 18.50 V/m; Power Drift = 0.03 dB

Peak SAR (extrapolated) = 0.492 W/kg

SAR(1 g) = 0.350 W/kg; SAR(10 g) = 0.239 W/kg

Maximum value of SAR (measured) = 0.424 W/kg

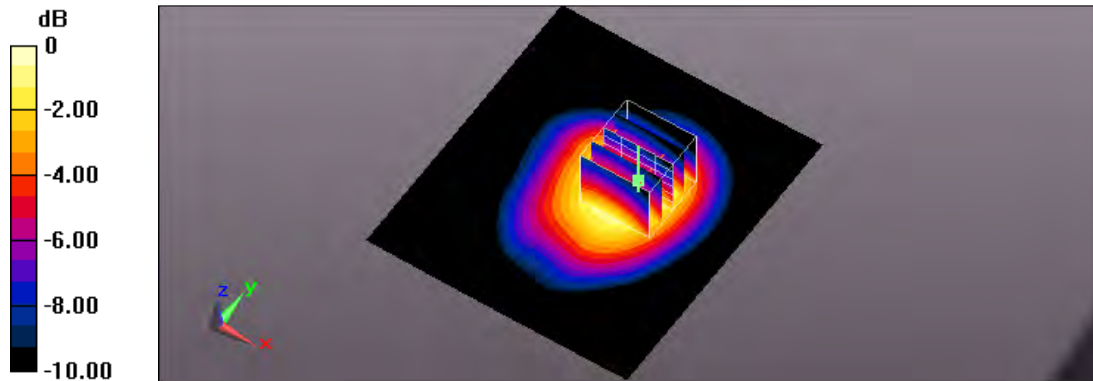

0 dB = 0.424 W/kg = -3.73 dBW/kg

Test Laboratory: A Test Lab Techno Corp.

Date/Time: 2016/11/23 AM 11:26:55

8_WCDMA Band V CH4183_Side3_5mm

DUT: BR828PGTW ; Type: POCSAG ALPHANUMERIC PAGER with 3G/GSM, GPS & Wi-Fi ; FCC ID: VDQ828-02

Communication System: UID 0, WCDMA Band V (0); Frequency: 836.6 MHz; Duty Cycle: 1:1

Medium parameters used: $f = 837$ MHz; $\sigma = 0.971$ S/m; $\epsilon_r = 54.339$; $\rho = 1000$ kg/m³

Phantom section: Flat Section

Measurement Standard: DASYS5 (IEEE/IEC/ANSI C63.19-2011)

DASY5.2 Configuration:

- Area Scan setting - Find Secondary Maximum Within: 2.0dB and with a peak SAR value greater than 0.5 W/Kg
- Probe: EX3DV4 - SN3977; ConvF(9.82, 9.82, 9.82); Calibrated: 2016/3/9;
- Sensor-Surface: 2mm (Mechanical Surface Detection)
- Electronics: DAE4 Sn779; Calibrated: 2016/3/2
- Phantom: ELI v4.0; Type: QDOVA001BB; Serial: TP:1036
- Measurement SW: DASYS52, Version 52.8 (8); SEMCAD X Version 14.6.10 (7331)

Flat/Area Scan (81x91x1):

Interpolated grid: $dx=1.500$ mm, $dy=1.500$ mm

Maximum value of SAR (interpolated) = 0.180 W/kg

Flat/Zoom Scan (5x5x7)/Cube 0:

Measurement grid: $dx=8$ mm, $dy=8$ mm, $dz=5$ mm

Reference Value = 14.02 V/m; Power Drift = 0.11 dB

Peak SAR (extrapolated) = 0.275 W/kg

SAR(1 g) = 0.152 W/kg; SAR(10 g) = 0.081 W/kg

Maximum value of SAR (measured) = 0.200 W/kg

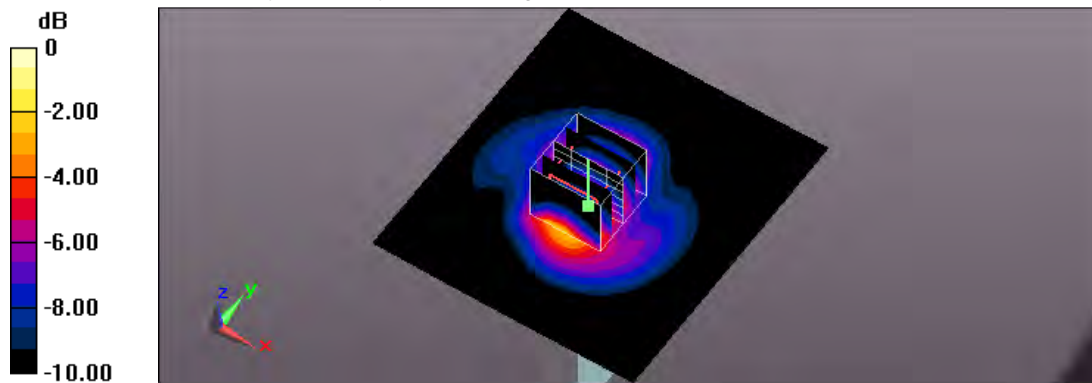

0 dB = 0.200 W/kg = -6.99 dBW/kg

Test Laboratory: A Test Lab Techno Corp.

Date/Time: 2016/11/23 AM 10:31:14

9_WCDMA Band V CH4183_Side5_5mm

DUT: BR828PGTW ; Type: POCSAG ALPHANUMERIC PAGER with 3G/GSM, GPS & Wi-Fi ; FCC ID: VDQ828-02

Communication System: UID 0, WCDMA Band V (0); Frequency: 836.6 MHz; Duty Cycle: 1:1

Medium parameters used: $f = 837 \text{ MHz}$; $\sigma = 0.971 \text{ S/m}$; $\epsilon_r = 54.339$; $\rho = 1000 \text{ kg/m}^3$

Phantom section: Flat Section

Measurement Standard: DASYS5 (IEEE/IEC/ANSI C63.19-2011)

DASY5.2 Configuration:

- Area Scan setting - Find Secondary Maximum Within: 2.0dB and with a peak SAR value greater than 0.5 W/Kg
- Probe: EX3DV4 - SN3977; ConvF(9.82, 9.82, 9.82); Calibrated: 2016/3/9;
- Sensor-Surface: 2mm (Mechanical Surface Detection)
- Electronics: DAE4 Sn779; Calibrated: 2016/3/2
- Phantom: ELI v4.0; Type: QDOVA001BB; Serial: TP:1036
- Measurement SW: DASYS52, Version 52.8 (8); SEMCAD X Version 14.6.10 (7331)

Flat/Area Scan (81x91x1):

Interpolated grid: $dx=1.500 \text{ mm}$, $dy=1.500 \text{ mm}$

Maximum value of SAR (interpolated) = 0.202 W/kg

Flat/Zoom Scan (5x5x7)/Cube 0:

Measurement grid: $dx=8\text{mm}$, $dy=8\text{mm}$, $dz=5\text{mm}$

Reference Value = 12.34 V/m; Power Drift = -0.05 dB

Peak SAR (extrapolated) = 0.239 W/kg

SAR(1 g) = 0.155 W/kg; SAR(10 g) = 0.097 W/kg

Maximum value of SAR (measured) = 0.200 W/kg

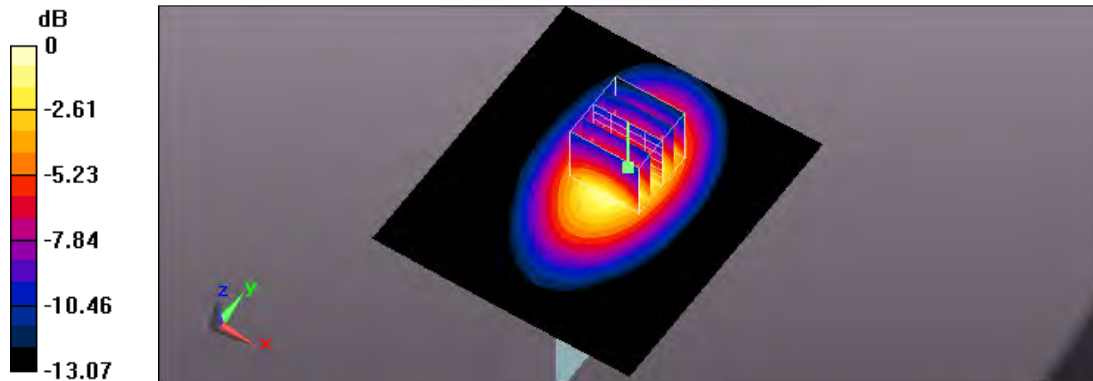

0 dB = 0.200 W/kg = -6.99 dBW/kg

Test Laboratory: A Test Lab Techno Corp.

Date/Time: 2016/11/23 AM 10:50:41

10_WCDMA Band V CH4183_Side6_5mm

DUT: BR828PGTW ; Type: POCSAG ALPHANUMERIC PAGER with 3G/GSM, GPS & Wi-Fi ; FCC ID: VDQ828-02

Communication System: UID 0, WCDMA Band V (0); Frequency: 836.6 MHz; Duty Cycle: 1:1

Medium parameters used: $f = 837 \text{ MHz}$; $\sigma = 0.971 \text{ S/m}$; $\epsilon_r = 54.339$; $\rho = 1000 \text{ kg/m}^3$

Phantom section: Flat Section

Measurement Standard: DASYS5 (IEEE/IEC/ANSI C63.19-2011)

DASY5.2 Configuration:

- Area Scan setting - Find Secondary Maximum Within: 2.0dB and with a peak SAR value greater than 0.5 W/Kg
- Probe: EX3DV4 - SN3977; ConvF(9.82, 9.82, 9.82); Calibrated: 2016/3/9;
- Sensor-Surface: 2mm (Mechanical Surface Detection)
- Electronics: DAE4 Sn779; Calibrated: 2016/3/2
- Phantom: ELI v4.0; Type: QDOVA001BB; Serial: TP:1036
- Measurement SW: DASYS52, Version 52.8 (8); SEMCAD X Version 14.6.10 (7331)

Flat/Area Scan (81x91x1):

Interpolated grid: $dx=1.500 \text{ mm}$, $dy=1.500 \text{ mm}$

Maximum value of SAR (interpolated) = 0.102 W/kg

Flat/Zoom Scan (5x5x7)/Cube 0:

Measurement grid: $dx=8\text{mm}$, $dy=8\text{mm}$, $dz=5\text{mm}$

Reference Value = 8.111 V/m; Power Drift = 0.05 dB

Peak SAR (extrapolated) = 0.122 W/kg

SAR(1 g) = 0.084 W/kg; SAR(10 g) = 0.055 W/kg

Maximum value of SAR (measured) = 0.105 W/kg

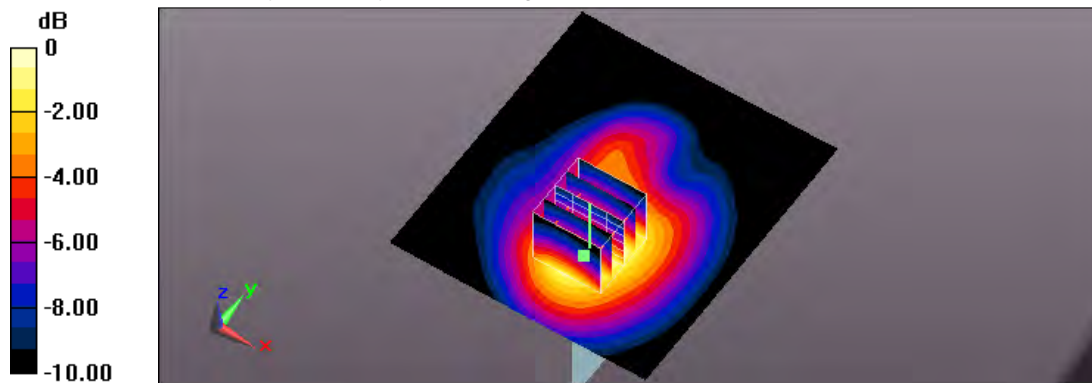

0 dB = 0.105 W/kg = -9.79 dBW/kg

Test Laboratory: A Test Lab Techno Corp.

Date/Time: 2016/12/5 PM 06:01:05

27_WCDMA Band V CH4183_Side2_with holder_0mm

DUT: BR828PGTW ; Type: POCSAG ALPHANUMERIC PAGER with 3G/GSM, GPS & Wi-Fi ; FCC ID: VDQ828-02

Communication System: UID 0, WCDMA Band V (0); Frequency: 836.6 MHz; Duty Cycle: 1:1

Medium parameters used: $f = 837 \text{ MHz}$; $\sigma = 0.971 \text{ S/m}$; $\epsilon_r = 54.339$; $\rho = 1000 \text{ kg/m}^3$

Phantom section: Flat Section

Measurement Standard: DASYS5 (IEEE/IEC/ANSI C63.19-2011)

DASY5.2 Configuration:

- Area Scan setting - Find Secondary Maximum Within: 2.0dB and with a peak SAR value greater than 0.5 W/Kg
- Probe: EX3DV4 - SN3977; ConvF(9.82, 9.82, 9.82); Calibrated: 2016/3/9;
- Sensor-Surface: 2mm (Mechanical Surface Detection)
- Electronics: DAE4 Sn779; Calibrated: 2016/3/2
- Phantom: ELI v4.0; Type: QDOVA001BB; Serial: TP:1036
- Measurement SW: DASYS52, Version 52.8 (8); SEMCAD X Version 14.6.10 (7331)

Flat/Area Scan (81x91x1):

Interpolated grid: $dx=1.500 \text{ mm}$, $dy=1.500 \text{ mm}$

Maximum value of SAR (interpolated) = 0.254 W/kg

Flat/Zoom Scan (5x5x7)/Cube 0:

Measurement grid: $dx=8\text{mm}$, $dy=8\text{mm}$, $dz=5\text{mm}$

Reference Value = 16.38 V/m; Power Drift = -0.03 dB

Peak SAR (extrapolated) = 0.287 W/kg

SAR(1 g) = 0.211 W/kg; SAR(10 g) = 0.146 W/kg

Maximum value of SAR (measured) = 0.246 W/kg

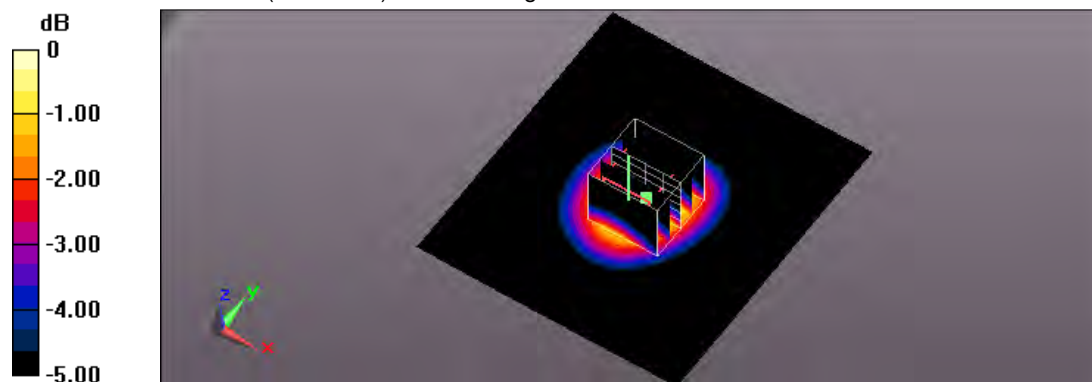

0 dB = 0.246 W/kg = -6.09 dBW/kg



Appendix C - Calibration

All of the instruments Calibration information are listed below.

- Dipole _ D835V2 SN:4d082 Calibration No.Z16-97134
- Dipole _ D1900V2 SN: 5d111 Calibration No.Z16-97134
- Probe _ EX3DV4 SN:3977 Calibration No. Z16-97020
- DAE _ DAE4 SN: 779 Calibration No. Z16-97019



In Collaboration with
s p e a g
CALIBRATION LABORATORY



中国认可
国际互认
校准
CALIBRATION
CNAS L0570

Add: No.51 Xueyuan Road, Haidian District, Beijing, 100191, China
Tel: +86-10-62304633-2079 Fax: +86-10-62304633-2504
E-mail: cttl@chinattl.com [Http://www.chinattl.cn](http://www.chinattl.cn)

Client **ATL**

Certificate No: **Z16-97134**

CALIBRATION CERTIFICATE

Object **D835V2 - SN: 4d082**

Calibration Procedure(s) **FD-Z11-2-003-01
Calibration Procedures for dipole validation kits**

Calibration date: **August 23, 2016**

This calibration Certificate documents the traceability to national standards, which realize the physical units of measurements(SI). The measurements and the uncertainties with confidence probability are given on the following pages and are part of the certificate.

All calibrations have been conducted in the closed laboratory facility: environment temperature(22±3)°C and humidity<70%.

Calibration Equipment used (M&TE critical for calibration)

Primary Standards	ID #	Cal Date(Calibrated by, Certificate No.)	Scheduled Calibration
Power Meter NRP2	101919	27-Jun-16 (CTTL, No.J16X04777)	Jun-17
Power sensor NRP-Z91	101547	27-Jun-16 (CTTL, No.J16X04777)	Jun-17
Reference Probe EX3DVA	SN 3617	26-Aug-15(SPEAG,No.EX3-3617_Aug15)	Aug-16
DAE4	SN 777	26-Aug-15(SPEAG,No.DAE4-777_Aug15)	Aug-16
Secondary Standards	ID #	Cal Date(Calibrated by, Certificate No.)	Scheduled Calibration
Signal Generator E4438C	MY49071430	01-Feb-16 (CTTL, No.J16X00893)	Jan-17
Network Analyzer E5071C	MY46110673	26-Jan-16 (CTTL, No.J16X00894)	Jan-17

	Name	Function	Signature
Calibrated by:	Zhao Jing	SAR Test Engineer	
Reviewed by:	Qi Dianyuan	SAR Project Leader	
Approved by:	Lu Bingsong	Deputy Director of the laboratory	

Issued: August 26, 2016

This calibration certificate shall not be reproduced except in full without written approval of the laboratory.

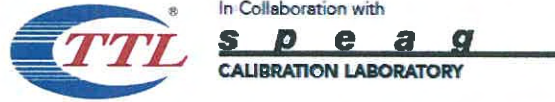

Add: No.51 Xueyuan Road, Haidian District, Beijing, 100191, China
Tel: +86-10-62304633-2079 Fax: +86-10-62304633-2504
E-mail: cttl@chinattl.com Http://www.chinattl.cn

Glossary:

TSL	tissue simulating liquid
ConvF	sensitivity in TSL / NORM _{x,y,z}
N/A	not applicable or not measured

Calibration is Performed According to the Following Standards:

- IEEE Std 1528-2013, "IEEE Recommended Practice for Determining the Peak Spatial-Averaged Specific Absorption Rate (SAR) in the Human Head from Wireless Communications Devices: Measurement Techniques", June 2013
- IEC 62209-1, "Procedure to measure the Specific Absorption Rate (SAR) For hand-held devices used in close proximity to the ear (frequency range of 300MHz to 3GHz)", February 2005
- IEC 62209-2, "Procedure to measure the Specific Absorption Rate (SAR) For wireless communication devices used in close proximity to the human body (frequency range of 30MHz to 6GHz)", March 2010
- KDB865664, SAR Measurement Requirements for 100 MHz to 6 GHz

Additional Documentation:

- DASY4/5 System Handbook

Methods Applied and Interpretation of Parameters:

- Measurement Conditions:* Further details are available from the Validation Report at the end of the certificate. All figures stated in the certificate are valid at the frequency indicated.
- Antenna Parameters with TSL:* The dipole is mounted with the spacer to position its feed point exactly below the center marking of the flat phantom section, with the arms oriented parallel to the body axis.
- Feed Point Impedance and Return Loss:* These parameters are measured with the dipole positioned under the liquid filled phantom. The impedance stated is transformed from the measurement at the SMA connector to the feed point. The Return Loss ensures low reflected power. No uncertainty required.
- Electrical Delay:* One-way delay between the SMA connector and the antenna feed point. No uncertainty required.
- SAR measured:* SAR measured at the stated antenna input power.
- SAR normalized:* SAR as measured, normalized to an input power of 1 W at the antenna connector.
- SAR for nominal TSL parameters:* The measured TSL parameters are used to calculate the nominal SAR result.

The reported uncertainty of measurement is stated as the standard uncertainty of Measurement multiplied by the coverage factor $k=2$, which for a normal distribution Corresponds to a coverage probability of approximately 95%.

Measurement Conditions

DASY system configuration, as far as not given on page 1.

DASY Version	DASY52	52.8.8.1258
Extrapolation	Advanced Extrapolation	
Phantom	Triple Flat Phantom 5.1C	
Distance Dipole Center - TSL	15 mm	with Spacer
Zoom Scan Resolution	dx, dy, dz = 5 mm	
Frequency	835 MHz ± 1 MHz	

Head TSL parameters

The following parameters and calculations were applied.

	Temperature	Permittivity	Conductivity
Nominal Head TSL parameters	22.0 °C	41.5	0.90 mho/m
Measured Head TSL parameters	(22.0 ± 0.2) °C	42.0 ± 6 %	0.92 mho/m ± 6 %
Head TSL temperature change during test	<1.0 °C	----	----

SAR result with Head TSL

SAR averaged over 1 cm ³ (1 g) of Head TSL	Condition	
SAR measured	250 mW input power	2.38 mW / g
SAR for nominal Head TSL parameters	normalized to 1W	9.43 mW / g ± 20.8 % (k=2)
SAR averaged over 10 cm ³ (10 g) of Head TSL	Condition	
SAR measured	250 mW input power	1.56 mW / g
SAR for nominal Head TSL parameters	normalized to 1W	6.19 mW / g ± 20.4 % (k=2)

Body TSL parameters

The following parameters and calculations were applied.

	Temperature	Permittivity	Conductivity
Nominal Body TSL parameters	22.0 °C	55.2	0.97 mho/m
Measured Body TSL parameters	(22.0 ± 0.2) °C	54.9 ± 6 %	0.98 mho/m ± 6 %
Body TSL temperature change during test	<1.0 °C	----	----

SAR result with Body TSL

SAR averaged over 1 cm ³ (1 g) of Body TSL	Condition	
SAR measured	250 mW input power	2.43 mW / g
SAR for nominal Body TSL parameters	normalized to 1W	9.65 mW / g ± 20.8 % (k=2)
SAR averaged over 10 cm ³ (10 g) of Body TSL	Condition	
SAR measured	250 mW input power	1.62 mW / g
SAR for nominal Body TSL parameters	normalized to 1W	6.44 mW / g ± 20.4 % (k=2)



In Collaboration with
s p e a g
 CALIBRATION LABORATORY

Add: No.51 Xueyuan Road, Haidian District, Beijing, 100191, China
 Tel: +86-10-62304633-2079 Fax: +86-10-62304633-2504
 E-mail: cttl@chinattl.com Http://www.chinattl.cn

Appendix

Antenna Parameters with Head TSL

Impedance, transformed to feed point	49.9Ω- 3.52jΩ
Return Loss	- 29.0dB

Antenna Parameters with Body TSL

Impedance, transformed to feed point	46.7Ω- 4.79jΩ
Return Loss	- 24.4dB

General Antenna Parameters and Design

Electrical Delay (one direction)	1.501 ns
----------------------------------	----------

After long term use with 100W radiated power, only a slight warming of the dipole near the feedpoint can be measured.

The dipole is made of standard semirigid coaxial cable. The center conductor of the feeding line is directly connected to the second arm of the dipole. The antenna is therefore short-circuited for DC-signals. On some of the dipoles, small end caps are added to the dipole arms in order to improve matching when loaded according to the position as explained in the "Measurement Conditions" paragraph. The SAR data are not affected by this change. The overall dipole length is still according to the Standard. No excessive force must be applied to the dipole arms, because they might bend or the soldered connections near the feedpoint may be damaged.

Additional EUT Data

Manufactured by	SPEAG
-----------------	-------

DASY5 Validation Report for Head TSL

Date: 08.23.2016

Test Laboratory: CTTL, Beijing, China

DUT: Dipole 835 MHz; Type: D835V2; Serial: D835V2 - SN: 4d082

Communication System: UID 0, CW; Frequency: 835 MHz; Duty Cycle: 1:1

Medium parameters used: $f = 835$ MHz; $\sigma = 0.915$ S/m; $\epsilon_r = 41.98$; $\rho = 1000$ kg/m³

Phantom section: Center Section

Measurement Standard: DASY5 (IEEE/IEC/ANSI C63.19-2007)

DASY5 Configuration:

- Probe: EX3DV4 - SN3617; ConvF(9.56, 9.56, 9.56); Calibrated: 8/26/2015;
- Sensor-Surface: 2mm (Mechanical Surface Detection)
- Electronics: DAE4 Sn777; Calibrated: 2015-08-26
- Phantom: Triple Flat Phantom 5.1C; Type: QD 000 P51 CA; Serial: 1161/1
- Measurement SW: DASY52, Version 52.8 (8); SEMCAD X Version 14.6.10 (7372)

Dipole Calibration/Zoom Scan (7x7x7) (7x7x7)/Cube 0: Measurement grid: dx=5mm, dy=5mm, dz=5mm

Reference Value = 58.25V/m; Power Drift = -0.02 dB

Peak SAR (extrapolated) = 3.55 W/kg

SAR(1 g) = 2.38 W/kg; SAR(10 g) = 1.56 W/kg

Maximum value of SAR (measured) = 3.02 W/kg

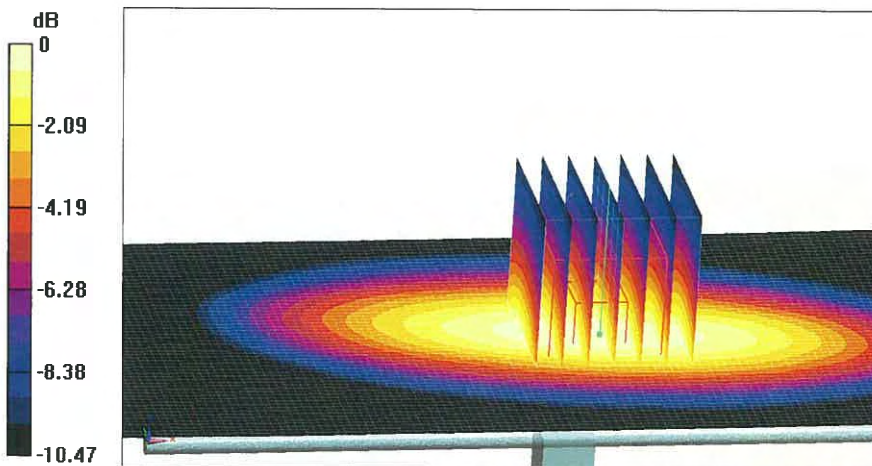

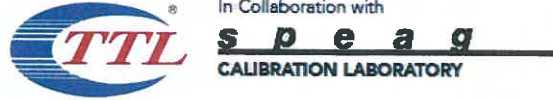

Add: No.51 Xueyuan Road, Haidian District, Beijing, 100191, China
Tel: +86-10-62304633-2079 Fax: +86-10-62304633-2504
E-mail: cttl@chinattl.com Http://www.chinattl.cn

Impedance Measurement Plot for Head TSL

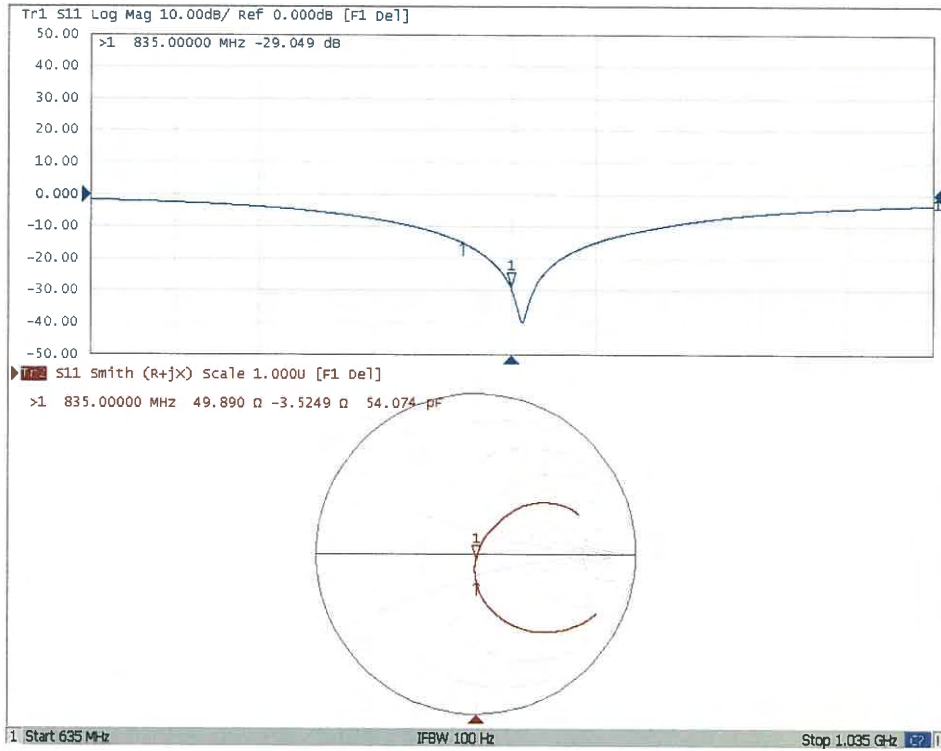

DASY5 Validation Report for Body TSL

Date: 08.23.2016

Test Laboratory: CCTL, Beijing, China

DUT: Dipole 835 MHz; Type: D835V2; Serial: D835V2 - SN: 4d082

Communication System: UID 0, CW; Frequency: 835 MHz; Duty Cycle: 1:1

Medium parameters used: $f = 835 \text{ MHz}$; $\sigma = 0.978 \text{ S/m}$; $\epsilon_r = 54.86$; $\rho = 1000 \text{ kg/m}^3$

Phantom section: Left Section

Measurement Standard: DASY5 (IEEE/IEC/ANSI C63.19-2007)

DASY5 Configuration:

- Probe: EX3DV4 - SN3617; ConvF(9.71,9.71, 9.71); Calibrated: 8/26/2015;
- Sensor-Surface: 2mm (Mechanical Surface Detection)
- Electronics: DAE4 Sn777; Calibrated: 2015-08-26
- Phantom: Triple Flat Phantom 5.1C; Type: QD 000 P51 CA; Serial: 1161/1
- Measurement SW: DASY52, Version 52.8 (8); SEMCAD X Version 14.6.10 (7372)

Dipole Calibration/Zoom Scan (7x7x7) (7x7x7)/Cube 0: Measurement grid: $dx=5\text{mm}$, $dy=5\text{mm}$, $dz=5\text{mm}$

Reference Value = 55.66 V/m; Power Drift = 0.02 dB

Peak SAR (extrapolated) = 3.54 W/kg

SAR(1 g) = 2.43 W/kg; SAR(10 g) = 1.62 W/kg

Maximum value of SAR (measured) = 3.05 W/kg

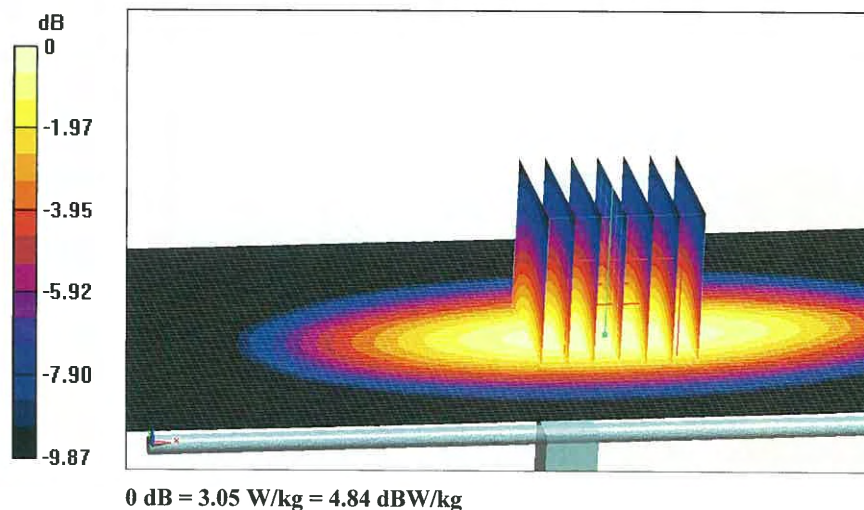



In Collaboration with
s p e a g
CALIBRATION LABORATORY

Add: No.51 Xueyuan Road, Haidian District, Beijing, 100191, China
Tel: +86-10-62304633-2079 Fax: +86-10-62304633-2504
E-mail: cttl@chinattl.com Http://www.chinattl.cn

Impedance Measurement Plot for Body TSL

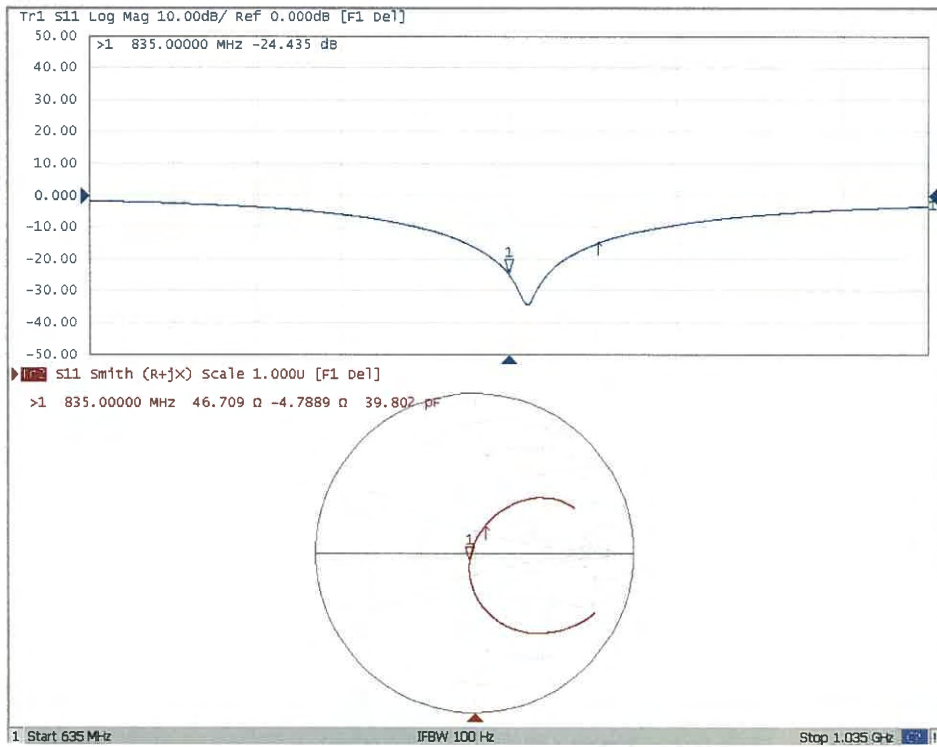



In Collaboration with
s p e a g
CALIBRATION LABORATORY



中国认可
国际互认
校准
CALIBRATION
CNAS L0570

Add: No.51 Xueyuan Road, Haidian District, Beijing, 100191, China
Tel: +86-10-62304633-2079 Fax: +86-10-62304633-2504
E-mail: cttl@chinattl.com [Http://www.chinattl.cn](http://www.chinattl.cn)

Client **ATL**

Certificate No: **Z16-97135**

CALIBRATION CERTIFICATE

Object: D1900V2 - SN: 5d111

Calibration Procedure(s): FD-Z11-2-003-01
Calibration Procedures for dipole validation kits

Calibration date: August 25, 2016

This calibration Certificate documents the traceability to national standards, which realize the physical units of measurements(SI). The measurements and the uncertainties with confidence probability are given on the following pages and are part of the certificate.

All calibrations have been conducted in the closed laboratory facility: environment temperature(22±3)°C and humidity<70%.

Calibration Equipment used (M&TE critical for calibration)

Primary Standards	ID #	Cal Date(Calibrated by, Certificate No.)	Scheduled Calibration
Power Meter NRP2	101919	27-Jun-16 (CTTL, No.J16X04777)	Jun-17
Power sensor NRP-Z91	101547	27-Jun-16 (CTTL, No.J16X04777)	Jun-17
Reference Probe EX3DV4	SN 3617	26-Aug-15(SPEAG,No.EX3-3617_Aug15)	Aug-16
DAE4	SN 777	26-Aug-15(SPEAG,No.DAE4-777_Aug15)	Aug-16
Secondary Standards	ID #	Cal Date(Calibrated by, Certificate No.)	Scheduled Calibration
Signal Generator E4438C	MY49071430	01-Feb-16 (CTTL, No.J16X00893)	Jan-17
Network Analyzer E5071C	MY46110673	26-Jan-16 (CTTL, No.J16X00894)	Jan-17

	Name	Function	Signature
Calibrated by:	Zhao Jing	SAR Test Engineer	
Reviewed by:	Qi Dianyuan	SAR Project Leader	
Approved by:	Lu Bingsong	Deputy Director of the laboratory	

Issued: August 27, 2016

This calibration certificate shall not be reproduced except in full without written approval of the laboratory.

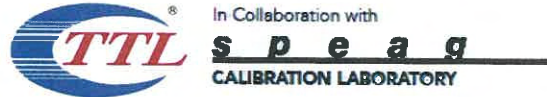

Add: No.51 Xueyuan Road, Haidian District, Beijing, 100191, China
Tel: +86-10-62304633-2079 Fax: +86-10-62304633-2504
E-mail: cttl@chinattl.com Http://www.chinattl.cn

Glossary:

TSL	tissue simulating liquid
ConvF	sensitivity in TSL / NORM _{x,y,z}
N/A	not applicable or not measured

Calibration is Performed According to the Following Standards:

- IEEE Std 1528-2013, "IEEE Recommended Practice for Determining the Peak Spatial-Averaged Specific Absorption Rate (SAR) in the Human Head from Wireless Communications Devices: Measurement Techniques", June 2013
- IEC 62209-1, "Procedure to measure the Specific Absorption Rate (SAR) For hand-held devices used in close proximity to the ear (frequency range of 300MHz to 3GHz)", February 2005
- IEC 62209-2, "Procedure to measure the Specific Absorption Rate (SAR) For wireless communication devices used in close proximity to the human body (frequency range of 30MHz to 6GHz)", March 2010
- KDB865664, SAR Measurement Requirements for 100 MHz to 6 GHz

Additional Documentation:

- DASY4/5 System Handbook

Methods Applied and Interpretation of Parameters:

- Measurement Conditions:* Further details are available from the Validation Report at the end of the certificate. All figures stated in the certificate are valid at the frequency indicated.
- Antenna Parameters with TSL:* The dipole is mounted with the spacer to position its feed point exactly below the center marking of the flat phantom section, with the arms oriented parallel to the body axis.
- Feed Point Impedance and Return Loss:* These parameters are measured with the dipole positioned under the liquid filled phantom. The impedance stated is transformed from the measurement at the SMA connector to the feed point. The Return Loss ensures low reflected power. No uncertainty required.
- Electrical Delay:* One-way delay between the SMA connector and the antenna feed point. No uncertainty required.
- SAR measured:* SAR measured at the stated antenna input power.
- SAR normalized:* SAR as measured, normalized to an input power of 1 W at the antenna connector.
- SAR for nominal TSL parameters:* The measured TSL parameters are used to calculate the nominal SAR result.

The reported uncertainty of measurement is stated as the standard uncertainty of Measurement multiplied by the coverage factor $k=2$, which for a normal distribution Corresponds to a coverage probability of approximately 95%.

Measurement Conditions

DASY system configuration, as far as not given on page 1.

DASY Version	DASY52	52.8.8.1258
Extrapolation	Advanced Extrapolation	
Phantom	Triple Flat Phantom 5.1C	
Distance Dipole Center - TSL	10 mm	with Spacer
Zoom Scan Resolution	dx, dy, dz = 5 mm	
Frequency	1900 MHz \pm 1 MHz	

Head TSL parameters

The following parameters and calculations were applied.

	Temperature	Permittivity	Conductivity
Nominal Head TSL parameters	22.0 °C	40.0	1.40 mho/m
Measured Head TSL parameters	(22.0 \pm 0.2) °C	39.4 \pm 6 %	1.38 mho/m \pm 6 %
Head TSL temperature change during test	<1.0 °C	----	----

SAR result with Head TSL

SAR averaged over 1 cm ³ (1 g) of Head TSL	Condition	
SAR measured	250 mW input power	9.99 mW / g
SAR for nominal Head TSL parameters	normalized to 1W	40.2 mW / g \pm 20.8 % (k=2)
SAR averaged over 10 cm ³ (10 g) of Head TSL	Condition	
SAR measured	250 mW input power	5.24 mW / g
SAR for nominal Head TSL parameters	normalized to 1W	21.0 mW / g \pm 20.4 % (k=2)

Body TSL parameters

The following parameters and calculations were applied.

	Temperature	Permittivity	Conductivity
Nominal Body TSL parameters	22.0 °C	53.3	1.52 mho/m
Measured Body TSL parameters	(22.0 \pm 0.2) °C	53.9 \pm 6 %	1.51 mho/m \pm 6 %
Body TSL temperature change during test	<1.0 °C	----	----

SAR result with Body TSL

SAR averaged over 1 cm ³ (1 g) of Body TSL	Condition	
SAR measured	250 mW input power	10.0 mW / g
SAR for nominal Body TSL parameters	normalized to 1W	40.3 mW / g \pm 20.8 % (k=2)
SAR averaged over 10 cm ³ (10 g) of Body TSL	Condition	
SAR measured	250 mW input power	5.33 mW / g
SAR for nominal Body TSL parameters	normalized to 1W	21.4 mW / g \pm 20.4 % (k=2)



Add: No.51 Xueyuan Road, Haidian District, Beijing, 100191, China
 Tel: +86-10-62304633-2079 Fax: +86-10-62304633-2504
 E-mail: cttl@chinattl.com Http://www.chinattl.cn

Appendix

Antenna Parameters with Head TSL

Impedance, transformed to feed point	50.2Ω+ 4.28jΩ
Return Loss	- 27.4dB

Antenna Parameters with Body TSL

Impedance, transformed to feed point	45.4Ω+ 4.02jΩ
Return Loss	- 23.9dB

General Antenna Parameters and Design

Electrical Delay (one direction)	1.314 ns
----------------------------------	----------

After long term use with 100W radiated power, only a slight warming of the dipole near the feedpoint can be measured.

The dipole is made of standard semirigid coaxial cable. The center conductor of the feeding line is directly connected to the second arm of the dipole. The antenna is therefore short-circuited for DC-signals. On some of the dipoles, small end caps are added to the dipole arms in order to improve matching when loaded according to the position as explained in the "Measurement Conditions" paragraph. The SAR data are not affected by this change. The overall dipole length is still according to the Standard. No excessive force must be applied to the dipole arms, because they might bend or the soldered connections near the feedpoint may be damaged.

Additional EUT Data

Manufactured by	SPEAG
-----------------	-------

DASY5 Validation Report for Head TSL

Date: 08.25.2016

Test Laboratory: CTTL, Beijing, China

DUT: Dipole 1900 MHz; Type: D1900V2; Serial: D1900V2 - SN: 5d111

Communication System: UID 0, CW; Frequency: 1900 MHz; Duty Cycle: 1:1

Medium parameters used: $f = 1900$ MHz; $\sigma = 1.379$ S/m; $\epsilon_r = 39.42$; $\rho = 1000$ kg/m³

Phantom section: Center Section

Measurement Standard: DASY5 (IEEE/IEC/ANSI C63.19-2007)

DASY5 Configuration:

- Probe: EX3DV4 - SN3617; ConvF(8.07, 8.07, 8.07); Calibrated: 8/26/2015;
- Sensor-Surface: 2mm (Mechanical Surface Detection)
- Electronics: DAE4 Sn777; Calibrated: 8/26/2015
- Phantom: Triple Flat Phantom 5.1C; Type: QD 000 P51 CA; Serial: 1161/1
- Measurement SW: DASY52, Version 52.8 (8); SEMCAD X Version 14.6.10 (7372)

System Performance Check/Zoom Scan (7x7x7) (7x7x7)/Cube 0: Measurement grid:

$dx=5$ mm, $dy=5$ mm, $dz=5$ mm

Reference Value = 103.1V/m; Power Drift = -0.02 dB

Peak SAR (extrapolated) = 18.5W/kg

SAR(1 g) = 9.99 W/kg; SAR(10 g) = 5.24 W/kg

Maximum value of SAR (measured) = 14.3 W/kg

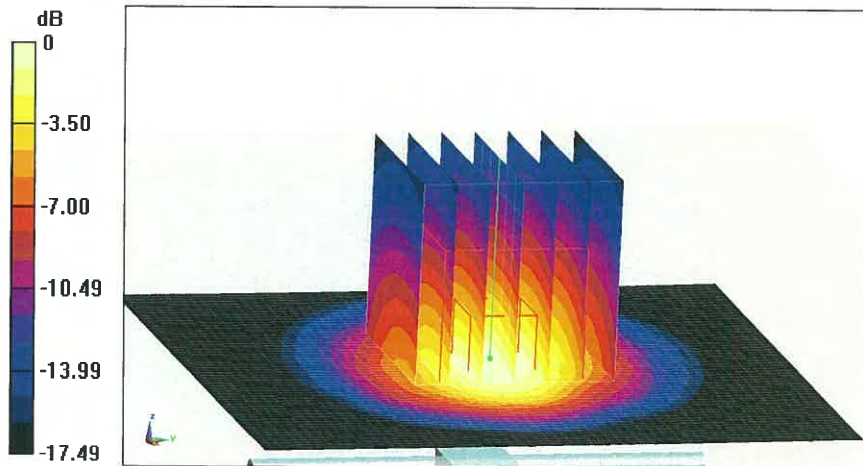

0 dB = 14.3 W/kg = 11.55 dBW/kg



Add: No.51 Xueyuan Road, Haidian District, Beijing, 100191, China
Tel: +86-10-62304633-2079 Fax: +86-10-62304633-2504
E-mail: cttl@chinattl.com Http://www.chinattl.cn

Impedance Measurement Plot for Head TSL

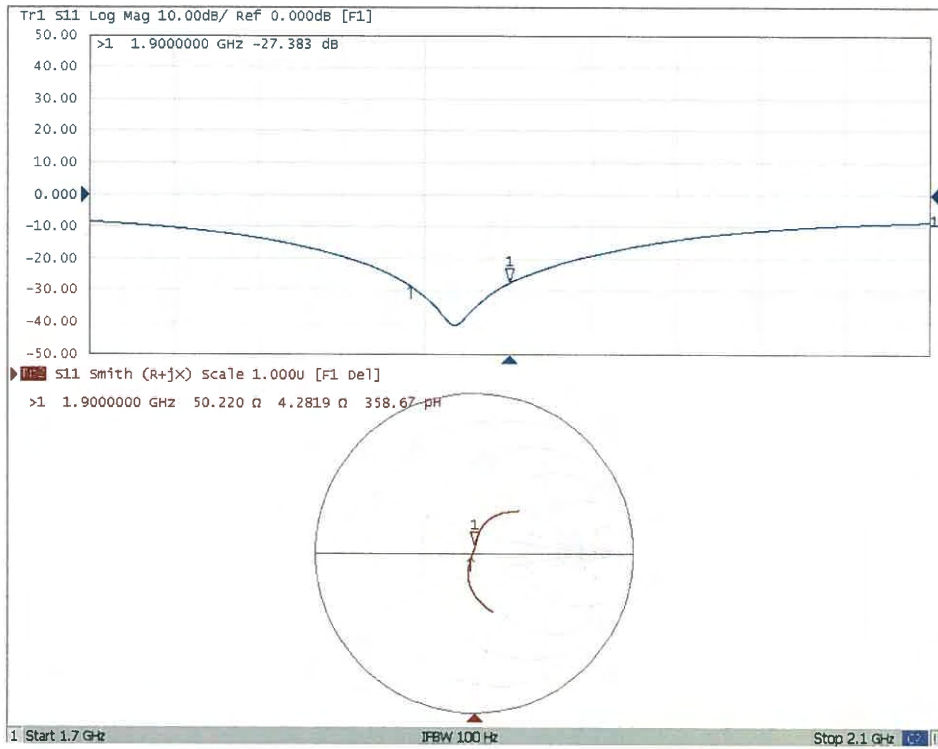

DASY5 Validation Report for Body TSL

Date: 08.25.2016

Test Laboratory: CTTL, Beijing, China

DUT: Dipole 1900 MHz; Type: D1900V2; Serial: D1900V2 - SN: 5d111

Communication System: UID 0, CW; Frequency: 1900 MHz; Duty Cycle: 1:1

Medium parameters used: $f = 1900$ MHz; $\sigma = 1.508$ S/m; $\epsilon_r = 53.92$; $\rho = 1000$ kg/m³

Phantom section: Left Section

Measurement Standard: DASY5 (IEEE/IEC/ANSI C63.19-2007)

DASY5 Configuration:

- Probe: EX3DV4 - SN3617; ConvF(7.74, 7.74, 7.74); Calibrated: 8/26/2015;
- Sensor-Surface: 2mm (Mechanical Surface Detection)
- Electronics: DAE4 Sn777; Calibrated: 8/26/2015
- Phantom: Triple Flat Phantom 5.1C; Type: QD 000 P51 CA; Serial: 1161/1
- Measurement SW: DASY52, Version 52.8 (8); SEMCAD X Version 14.6.10 (7372)

System Performance Check/Zoom Scan (7x7x7) (7x7x7)/Cube 0: Measurement grid:

$dx=5$ mm, $dy=5$ mm, $dz=5$ mm

Reference Value = 91.04 V/m; Power Drift = -0.01 dB

Peak SAR (extrapolated) = 17.8 W/kg

SAR(1 g) = 10 W/kg; SAR(10 g) = 5.33 W/kg

Maximum value of SAR (measured) = 14.1 W/kg

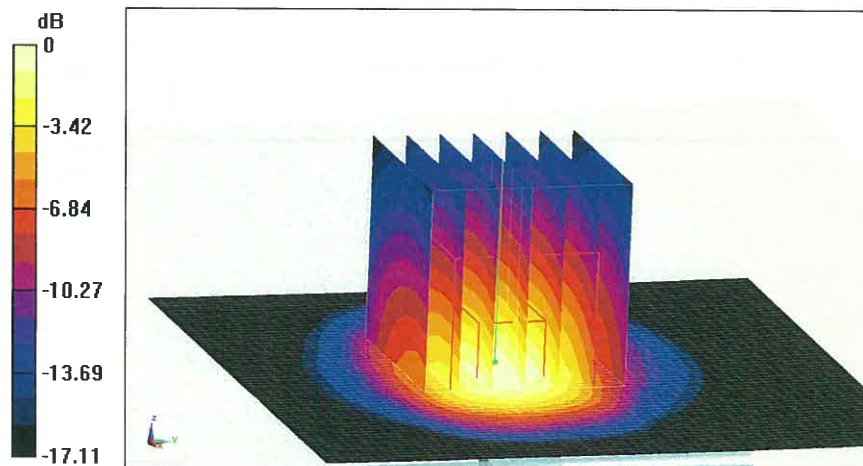

0 dB = 14.1 W/kg = 11.49 dBW/kg



Add: No.51 Xueyuan Road, Haidian District, Beijing, 100191, China
Tel: +86-10-62304633-2079 Fax: +86-10-62304633-2504
E-mail: cttl@chinattl.com Http://www.chinattl.cn

Impedance Measurement Plot for Body TSL

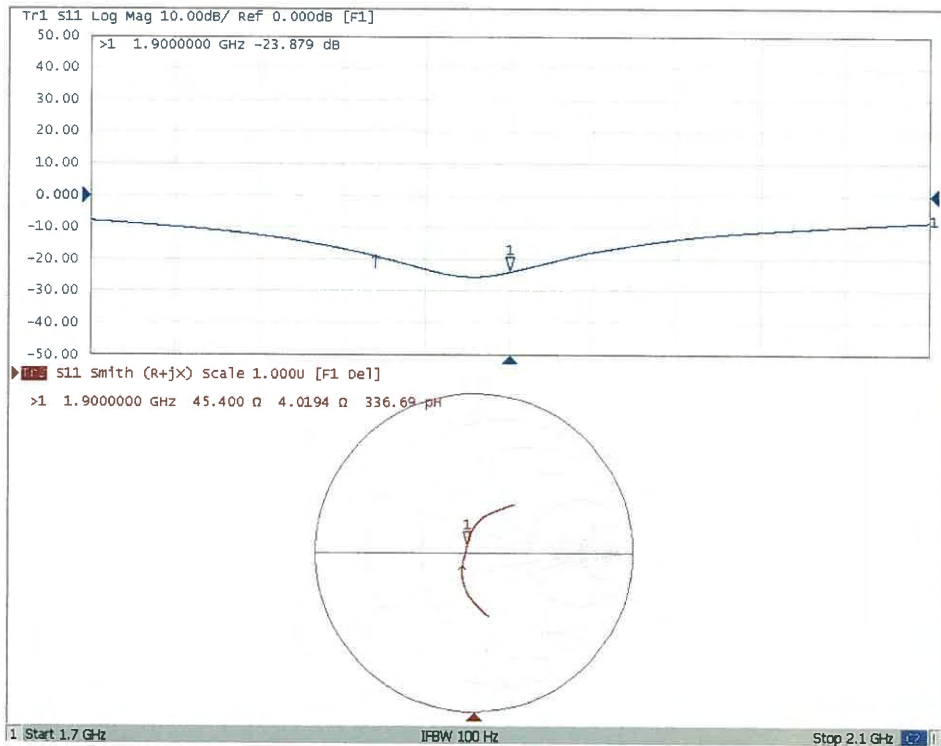



Add: No.51 Xueyuan Road, Haidian District, Beijing, 100191, China
 Tel: +86-10-62304633-2218 Fax: +86-10-62304633-2209
 E-mail: cttl@chinattl.com [Http://www.chinattl.cn](http://www.chinattl.cn)



中国认可
 国际互认
 校准
 CALIBRATION
 CNAS L0570

Client **ATL**

Certificate No: **Z16-97020**

CALIBRATION CERTIFICATE

Object: **EX3DV4 - SN:3977**

Calibration Procedure(s): **FD-Z11-2-004-01**
Calibration Procedures for Dosimetric E-field Probes

Calibration date: **March 09, 2016**

This calibration Certificate documents the traceability to national standards, which realize the physical units of measurements(SI). The measurements and the uncertainties with confidence probability are given on the following pages and are part of the certificate.

All calibrations have been conducted in the closed laboratory facility: environment temperature(22±3)°C and humidity<70%.

Calibration Equipment used (M&TE critical for calibration)

Primary Standards	ID #	Cal Date(Calibrated by, Certificate No.)	Scheduled Calibration
Power Meter NRP2	101919	01-Jul-15 (CTTL, No.J15X04256)	Jun-16
Power sensor NRP-Z91	101547	01-Jul-15 (CTTL, No.J15X04256)	Jun-16
Power sensor NRP-Z91	101548	01-Jul-15 (CTTL, No.J15X04256)	Jun-16
Reference10dBAttenuator	18N50W-10dB	13-Mar-14(TMC,No.JZ14-1103)	Mar-16
Reference20dBAttenuator	18N50W-20dB	13-Mar-14(TMC,No.JZ14-1104)	Mar-16
Reference Probe EX3DV4	SN 3617	26-Aug-15(SPEAG,No.EX3-3617_Aug15)	Aug-16
DAE4	SN 1331	21-Jan-16(SPEAG, No.DAE4-1331_Jan15)	Jan -17
Secondary Standards	ID #	Cal Date(Calibrated by, Certificate No.)	Scheduled Calibration
SignalGeneratorMG3700A	6201052605	01-Jul-15 (CTTL, No.J15X04255)	Jun-16
Network Analyzer E5071C	MY46110673	26-Jan-16 (CTTL, No.J16X00894)	Jan -17

	Name	Function	Signature
Calibrated by:	Yu Zongying	SAR Test Engineer	
Reviewed by:	Qi Dianyuan	SAR Project Leader	
Approved by:	Lu Bingsong	Deputy Director of the laboratory	

Issued: March 10, 2016

This calibration certificate shall not be reproduced except in full without written approval of the laboratory.

Glossary:

TSL	tissue simulating liquid
NORM _{x,y,z}	sensitivity in free space
ConvF	sensitivity in TSL / NORM _{x,y,z}
DCP	diode compression point
CF	crest factor (1/duty_cycle) of the RF signal
A,B,C,D	modulation dependent linearization parameters
Polarization Φ	Φ rotation around probe axis
Polarization θ	θ rotation around an axis that is in the plane normal to probe axis (at measurement center), i $\theta=0$ is normal to probe axis

Connector Angle information used in DASY system to align probe sensor X to the robot coordinate system

Calibration is Performed According to the Following Standards:

- a) IEEE Std 1528-2013, "IEEE Recommended Practice for Determining the Peak Spatial-Averaged Specific Absorption Rate (SAR) in the Human Head from Wireless Communications Devices: Measurement Techniques", June 2013
- b) IEC 62209-1, "Procedure to measure the Specific Absorption Rate (SAR) for hand-held devices used in close proximity to the ear (frequency range of 300MHz to 3GHz)", February 2005
- c) IEC 62209-2, "Procedure to determine the Specific Absorption Rate (SAR) for wireless communication devices used in close proximity to the human body (frequency range of 30 MHz to 6 GHz)", March 2010
- d) KDB 865664, "SAR Measurement Requirements for 100 MHz to 6 GHz"

Methods Applied and Interpretation of Parameters:

- *NORM_{x,y,z}*: Assessed for E-field polarization $\theta=0$ ($f \leq 900$ MHz in TEM-cell; $f > 1800$ MHz: waveguide). *NORM_{x,y,z}* are only intermediate values, i.e., the uncertainties of *NORM_{x,y,z}* does not effect the E^2 -field uncertainty inside TSL (see below ConvF).
- *NORM(f)_{x,y,z}* = *NORM_{x,y,z}* * *frequency_response* (see Frequency Response Chart). This linearization is implemented in DASY4 software versions later than 4.2. The uncertainty of the frequency response is included in the stated uncertainty of ConvF.
- *DCP_{x,y,z}*: DCP are numerical linearization parameters assessed based on the data of power sweep (no uncertainty required). DCP does not depend on frequency nor media.
- PAR: PAR is the Peak to Average Ratio that is not calibrated but determined based on the signal characteristics.
- *A_{x,y,z}; B_{x,y,z}; C_{x,y,z}; VR_{x,y,z}*: A,B,C are numerical linearization parameters assessed based on the data of power sweep for specific modulation signal. The parameters do not depend on frequency nor media. VR is the maximum calibration range expressed in RMS voltage across the diode.
- *ConvF and Boundary Effect Parameters*: Assessed in flat phantom using E-field (or Temperature Transfer Standard for $f \leq 800$ MHz) and inside waveguide using analytical field distributions based on power measurements for $f > 800$ MHz. The same setups are used for assessment of the parameters applied for boundary compensation (alpha, depth) of which typical uncertainty valued are given. These parameters are used in DASY4 software to improve probe accuracy close to the boundary. The sensitivity in TSL corresponds to *NORM_{x,y,z}* * ConvF whereby the uncertainty corresponds to that given for ConvF. A frequency dependent ConvF is used in DASY version 4.4 and higher which allows extending the validity from ± 50 MHz to ± 100 MHz.
- *Spherical isotropy (3D deviation from isotropy)*: in a field of low gradients realized using a flat phantom exposed by a patch antenna.
- *Sensor Offset*: The sensor offset corresponds to the offset of virtual measurement center from the probe tip (on probe axis). No tolerance required.
- *Connector Angle*: The angle is assessed using the information gained by determining the *NORM_x* (no uncertainty required).



Add: No.51 Xueyuan Road, Haidian District, Beijing, 100191, China
Tel: +86-10-62304633-2218 Fax: +86-10-62304633-2209
E-mail: ctl@chinatl.com [Http://www.chinatl.cn](http://www.chinatl.cn)

Probe EX3DV4

SN: 3977

Calibrated: March 09, 2016

Calibrated for DASY/EASY Systems

(Note: non-compatible with DASY2 system!)

DASY/EASY – Parameters of Probe: EX3DV4 – SN: 3977

Basic Calibration Parameters

	Sensor X	Sensor Y	Sensor Z	Unc (k=2)
Norm($\mu\text{V}/(\text{V}/\text{m})^2$) ^A	0.53	0.58	0.51	±10.8%
DCP(mV) ^B	102.9	103.1	100.6	

Modulation Calibration Parameters

UID	Communication System Name		A dB	B dB $\sqrt{\mu\text{V}}$	C	D dB	VR mV	Unc ^E (k=2)
0	CW	X	0.0	0.0	1.0	0.00	208.7	±2.2%
		Y	0.0	0.0	1.0		215.6	
		Z	0.0	0.0	1.0		202.6	

The reported uncertainty of measurement is stated as the standard uncertainty of Measurement multiplied by the coverage factor k=2, which for a normal distribution Corresponds to a coverage probability of approximately 95%.

^A The uncertainties of Norm X, Y, Z do not affect the E²-field uncertainty inside TSL (see Page 5 and Page 6).

^B Numerical linearization parameter: uncertainty not required.

^E Uncertainty is determined using the max. deviation from linear response applying rectangular distribution and is expressed for the square of the field value.

DASY/EASY – Parameters of Probe: EX3DV4 – SN: 3977

Calibration Parameter Determined in Head Tissue Simulating Media

f [MHz] ^C	Relative Permittivity ^F	Conductivity (S/m) ^F	ConvF X	ConvF Y	ConvF Z	Alpha ^G	Depth ^G (mm)	Unct. (k=2)
750	41.9	0.89	9.82	9.82	9.82	0.30	0.75	± 12%
835	41.5	0.90	9.62	9.62	9.62	0.15	1.37	± 12%
900	41.5	0.97	9.55	9.55	9.55	0.12	1.62	± 12%
1750	40.1	1.37	8.36	8.36	8.36	0.14	1.88	± 12%
1900	40.0	1.40	8.02	8.02	8.02	0.14	1.96	± 12%
2000	40.0	1.40	8.02	8.02	8.02	0.12	2.81	± 12%
2300	39.5	1.67	7.69	7.69	7.69	0.37	0.92	± 12%
2450	39.2	1.80	7.28	7.28	7.28	0.29	1.21	± 12%
2600	39.0	1.96	7.18	7.18	7.18	0.31	1.20	± 12%
5200	36.0	4.66	5.45	5.45	5.45	0.48	1.28	± 13%
5300	35.9	4.76	5.25	5.25	5.25	0.48	1.32	± 13%
5500	35.6	4.96	5.05	5.05	5.05	0.48	1.25	± 13%
5600	35.5	5.07	4.82	4.82	4.82	0.50	1.33	± 13%
5800	35.3	5.27	4.83	4.83	4.83	0.50	1.41	± 13%

^C Frequency validity of ±100MHz only applies for DASY v4.4 and higher (Page 2), else it is restricted to ±50MHz. The uncertainty is the RSS of ConvF uncertainty at calibration frequency and the uncertainty for the indicated frequency band.

^F At frequency below 3 GHz, the validity of tissue parameters (ϵ and σ) can be relaxed to ±10% if liquid compensation formula is applied to measured SAR values. At frequencies above 3 GHz, the validity of tissue parameters (ϵ and σ) is restricted to ±5%. The uncertainty is the RSS of the ConvF uncertainty for indicated target tissue parameters.

^G Alpha/Depth are determined during calibration. SPEAG warrants that the remaining deviation due to the boundary effect after compensation is always less than ± 1% for frequencies below 3 GHz and below ± 2% for the frequencies between 3-6 GHz at any distance larger than half the probe tip diameter from the boundary.

DASY/EASY – Parameters of Probe: EX3DV4 – SN: 3977

Calibration Parameter Determined in Body Tissue Simulating Media

f [MHz] ^C	Relative Permittivity ^F	Conductivity (S/m) ^F	ConvF X	ConvF Y	ConvF Z	Alpha ^G	Depth ^G (mm)	Unct. (k=2)
750	55.5	0.96	9.95	9.95	9.95	0.38	0.82	±12%
835	55.2	0.97	9.82	9.82	9.82	0.14	1.60	±12%
900	55.0	1.05	9.67	9.67	9.67	0.18	1.35	±12%
1750	53.4	1.49	8.00	8.00	8.00	0.15	2.18	±12%
1900	53.3	1.52	7.66	7.66	7.66	0.15	2.66	±12%
2000	53.3	1.52	7.80	7.80	7.80	0.15	3.21	±12%
2300	52.9	1.81	7.33	7.33	7.33	0.28	1.43	±12%
2450	52.7	1.95	7.30	7.30	7.30	0.30	1.40	±12%
2600	52.5	2.16	7.08	7.08	7.08	0.37	1.05	±12%
5200	49.0	5.30	4.81	4.81	4.81	0.44	1.58	±13%
5300	48.9	5.42	4.61	4.61	4.61	0.44	1.80	±13%
5500	48.6	5.65	4.31	4.31	4.31	0.46	1.80	±13%
5600	48.5	5.77	4.21	4.21	4.21	0.48	1.85	±13%
5800	48.2	6.00	4.33	4.33	4.33	0.50	1.60	±13%

^C Frequency validity of ±100MHz only applies for DASY v4.4 and higher (Page 2), else it is restricted to ±50MHz. The uncertainty is the RSS of ConvF uncertainty at calibration frequency and the uncertainty for the indicated frequency band.

^F At frequency below 3 GHz, the validity of tissue parameters (ϵ and σ) can be relaxed to ±10% if liquid compensation formula is applied to measured SAR values. At frequencies above 3 GHz, the validity of tissue parameters (ϵ and σ) is restricted to ±5%. The uncertainty is the RSS of the ConvF uncertainty for indicated target tissue parameters.

^G Alpha/Depth are determined during calibration. SPEAG warrants that the remaining deviation due to the boundary effect after compensation is always less than ± 1% for frequencies below 3 GHz and below ± 2% for the frequencies between 3-6 GHz at any distance larger than half the probe tip diameter from the boundary.

Frequency Response of E-Field (TEM-Cell: ifi110 EXX, Waveguide: R22)

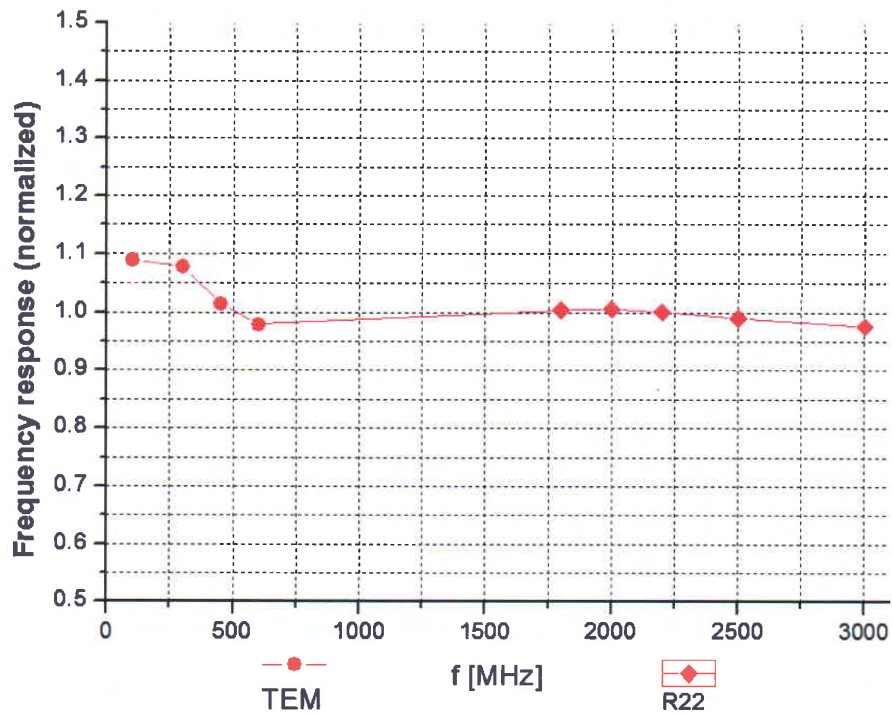

Uncertainty of Frequency Response of E-field: $\pm 7.5\%$ (k=2)

Receiving Pattern (Φ), $\theta=0^\circ$

f=600 MHz, TEM

f=1800 MHz, R22

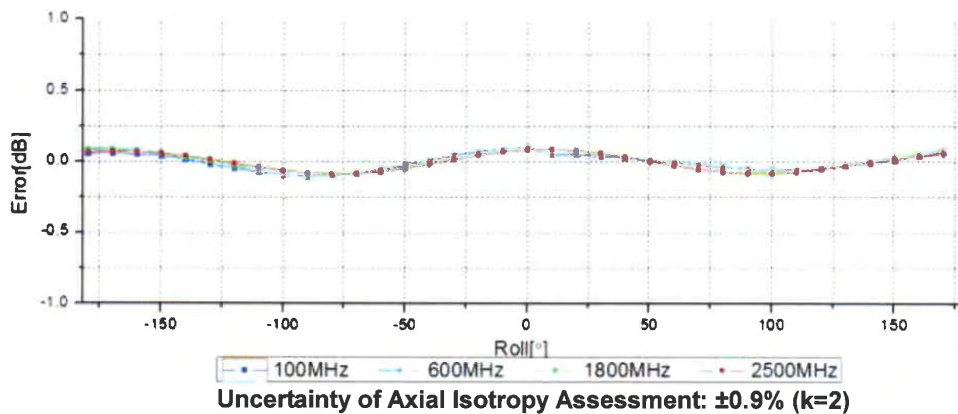
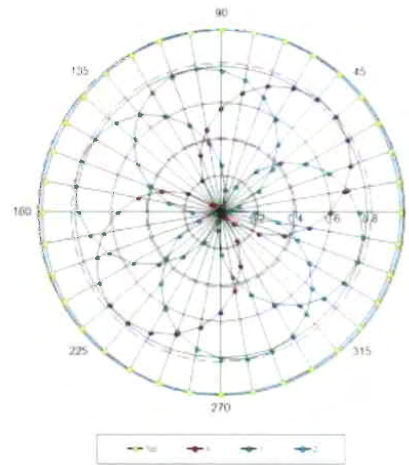
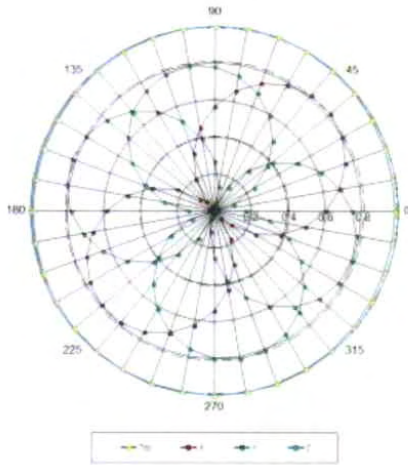

Dynamic Range f(SAR_{head}) (TEM cell, f = 900 MHz)

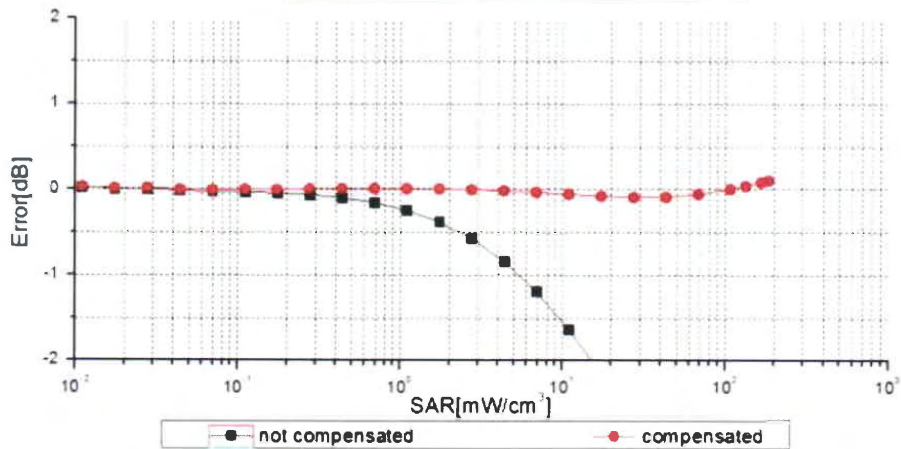
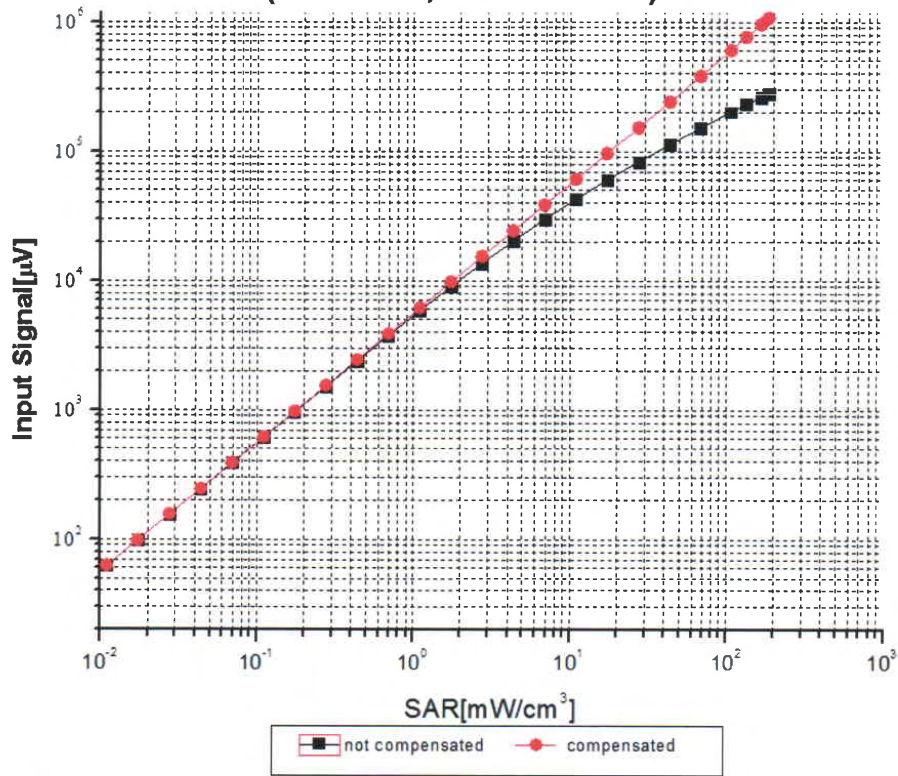

Uncertainty of Linearity Assessment: ±0.9% (k=2)

Conversion Factor Assessment

f=900 MHz, WGLS R9(H_convF)

f=1750 MHz, WGLS R22(H_convF)

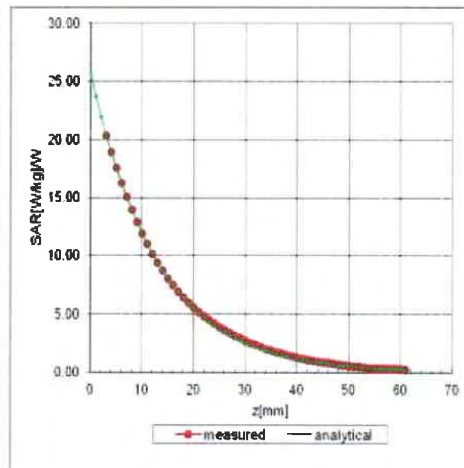
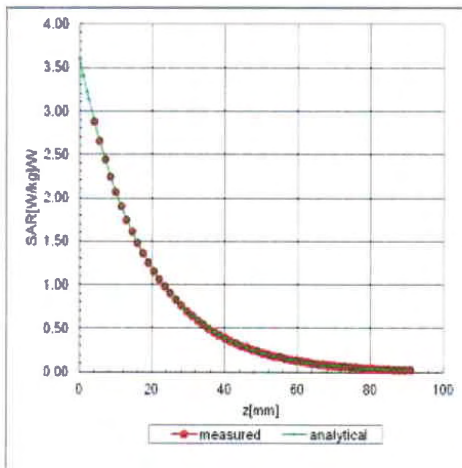

Deviation from Isotropy in Liquid

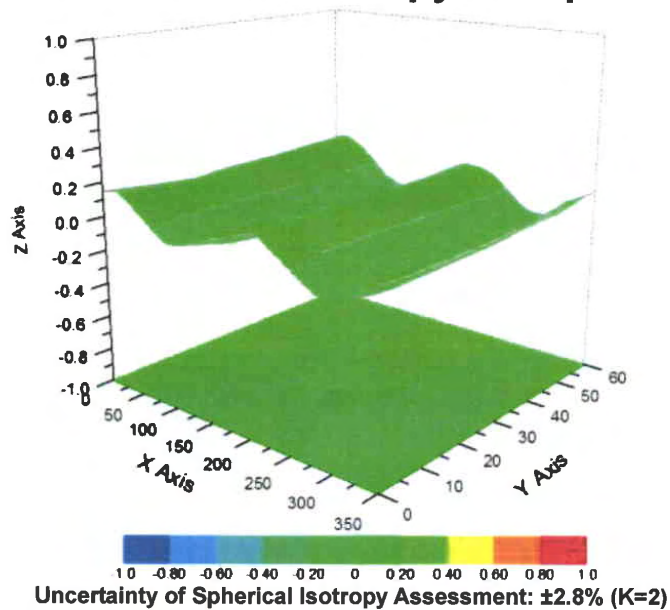



Add: No.51 Xueyuan Road, Haidian District, Beijing, 100191, China
 Tel: +86-10-62304633-2218 Fax: +86-10-62304633-2209
 E-mail: cttl@chinattl.com [Http://www.chinattl.cn](http://www.chinattl.cn)

DASY/EASY – Parameters of Probe: EX3DV4 – SN: 3977

Other Probe Parameters

Sensor Arrangement	Triangular
Connector Angle (°)	26.4
Mechanical Surface Detection Mode	enabled
Optical Surface Detection Mode	disable
Probe Overall Length	337mm
Probe Body Diameter	10mm
Tip Length	9mm
Tip Diameter	2.5mm
Probe Tip to Sensor X Calibration Point	1mm
Probe Tip to Sensor Y Calibration Point	1mm
Probe Tip to Sensor Z Calibration Point	1mm
Recommended Measurement Distance from Surface	1.4mm

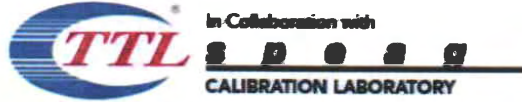

Add: No.51 Xueyuan Road, Haidian District, Beijing, 100191, China
 Tel: +86-10-62304633-2218 Fax: +86-10-62304633-2209
 E-mail: cttl@chinattl.com [Http://www.chinattl.cn](http://www.chinattl.cn)



中国认可
 国际互认
 校准
 CALIBRATION
 CNAS L0570

Client : **ATL**

Certificate No: **Z16-97019**

CALIBRATION CERTIFICATE

Object: **DAE4 - SN: 779**

Calibration Procedure(s): **FD-Z11-2-002-01**
 Calibration Procedure for the Data Acquisition Electronics (DAEx)

Calibration date: **March 2, 2016**

This calibration Certificate documents the traceability to national standards, which realize the physical units of measurements(SI). The measurements and the uncertainties with confidence probability are given on the following pages and are part of the certificate.

All calibrations have been conducted in the closed laboratory facility: environment temperature(22±3)°C and humidity<70%.

Calibration Equipment used (M&TE critical for calibration)

Primary Standards	ID #	Cal Date(Calibrated by, Certificate No.)	Scheduled Calibration
Process Calibrator 753	1971018	06-July-15 (CTTL, No:J15X04257)	July-16

	Name	Function	Signature
Calibrated by:	Yu Zongying	SAR Test Engineer	
Reviewed by:	Qi Dianyuan	SAR Project Leader	
Approved by:	Lu Bingsong	Deputy Director of the laboratory	

Issued: **March 3, 2016**

This calibration certificate shall not be reproduced except in full without written approval of the laboratory.

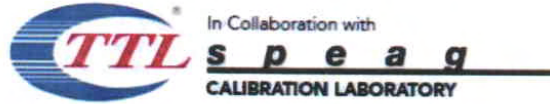

Add: No.51 Xueyuan Road, Haidian District, Beijing, 100191, China
Tel: +86-10-62304633-2218 Fax: +86-10-62304633-2209
E-mail: cttl@chinattl.com Http://www.chinattl.cn

Glossary:

DAE data acquisition electronics
Connector angle information used in DASY system to align probe sensor X to the robot coordinate system.

Methods Applied and Interpretation of Parameters:

- *DC Voltage Measurement:* Calibration Factor assessed for use in DASY system by comparison with a calibrated instrument traceable to national standards. The figure given corresponds to the full scale range of the voltmeter in the respective range.
- *Connector angle:* The angle of the connector is assessed measuring the angle mechanically by a tool inserted. Uncertainty is not required.
- The report provide only calibration results for DAE, it does not contain other performance test results.

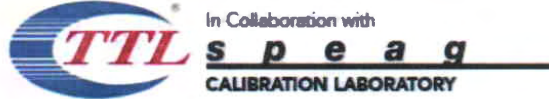

In Collaboration with
TTL speag
CALIBRATION LABORATORY

Add: No.51 Xueyuan Road, Haidian District, Beijing, 100191, China
 Tel: +86-10-62304633-2218 Fax: +86-10-62304633-2209
 E-mail: cttl@chinattl.com Http://www.chinattl.cn

DC Voltage Measurement

A/D - Converter Resolution nominal
 High Range: 1LSB = 6.1μV , full range = -100...+300 mV
 Low Range: 1LSB = 61nV , full range = -1.....+3mV
 DASY measurement parameters: Auto Zero Time: 3 sec; Measuring time: 3 sec

Calibration Factors	X	Y	Z
High Range	404.044 ± 0.15% (k=2)	403.722 ± 0.15% (k=2)	403.947 ± 0.15% (k=2)
Low Range	3.97041 ± 0.7% (k=2)	3.98123 ± 0.7% (k=2)	3.99689 ± 0.7% (k=2)

Connector Angle

Connector Angle to be used in DASY system	158 ± 1 °
---	-----------