

FCC Test Report

FCC ID : N7NHL7588
Equipment : Wireless Module
Model No. : HL7588
Brand Name : AirPrime
Applicant : Sierra Wireless Inc.
Address : 13811 Wireless Way Richmond, BC, V6V 3A4
Canada
Standard : 47 CFR FCC Part 27 Subpart L
Received Date : Jul. 16, 2015
Tested Date : Jul. 20 ~ Jul. 30, 2015

We, International Certification Corp., would like to declare that the tested sample has been evaluated and in compliance with the requirement of the above standards. The test results contained in this report refer exclusively to the product. It may be duplicated completely for legal use with the approval of the applicant. It shall not be reproduced except in full without the written approval of our laboratory.

Approved & Reviewed by:



Gary Chang / Manager



Table of Contents

1	GENERAL DESCRIPTION	5
1.1	Information.....	5
1.2	Local Support Equipment List	7
1.3	Test Setup Chart	7
1.4	The Equipment List	8
1.5	Test Standards	9
1.6	Measurement Uncertainty	9
2	TEST CONFIGURATION.....	9
2.1	Testing Condition and Location Information.....	10
2.2	The Worst Test Modes and Channel Details	10
3	TEST RESULTS.....	11
3.1	Equivalent Isotropically Radiated Power	11
3.2	Radiated Emissions.....	18
3.3	Conducted Emissions.....	29
3.4	Band Edge.....	36
3.5	Occupied and 26 dB Bandwidth	61
3.6	Peak to Average Ratio	68
3.7	Frequency Stability	75
4	TEST LABORATORY INFORMATION	79

Release Record

Report No.	Version	Description	Issued Date
FG571601P27L	Rev. 01	Initial issue	Aug. 17, 2015
FG571601P27L	Rev. 02	Add temperature and humidity chamber in equipment list and modify test channel No. of 10MHz of P 21	Aug. 24, 2015

Summary of Test Results

FCC Rules	Test Items	Measured	Result
2.1046 / 27.50(d)(4)	Equivalent Isotropically Radiated Power	Power[dBm]: 26.22	Pass
2.1053 / 27.53(h)	Radiated Emissions	Meet the requirement of limit	Pass
2.1051 / 27.53(h)	Conducted Emissions	Meet the requirement of limit	Pass
27.53(h)	Band Edge Measurement	Meet the requirement of limit	Pass
2.1049 / 27.53(h)	Occupied Bandwidth	Meet the requirement of limit	Pass
27.50(d)(5)	Peak to Average Ratio	Meet the requirement of limit	Pass
2.1055 / 27.54	Frequency Stability	Meet the requirement of limit	Pass

1 General Description

1.1 Information

1.1.1 Specification of the Equipment under Test (EUT)

Operating Frequency (MHz)	Channel Bandwidth: 1.4MHz: 1710.7~1754.3 Channel Bandwidth: 3MHz: 1711.5~1753.5 Channel Bandwidth: 5MHz: 1712.5~1752.5 Channel Bandwidth: 10MHz: 1715~1750 Channel Bandwidth: 15MHz: 1717.5~1747.5 Channel Bandwidth: 20MHz: 1720~1745
Modulation Type	QPSK, 16QAM (Uplink)
Release Version	8
Duplex Mode	FDD
UE Category	4
H/W Version	1.0
S/W Version	HL75xx.V.3.1

1.1.2 Maximum EIRP and Emission Designator

Mode	Modulation	Maximum EIRP (W)	Emission Designator
LTE Band 4, CB: 1.4MHz	QPSK	0.406	1M09G7D
LTE Band 4, CB: 1.4MHz	16QAM	0.356	1M09W7D
LTE Band 4, CB: 3MHz	QPSK	0.368	2M69G7D
LTE Band 4, CB: 3MHz	16QAM	0.310	2M70W7D
LTE Band 4, CB: 5MHz	QPSK	0.397	4M51G7D
LTE Band 4, CB: 5MHz	16QAM	0.336	4M51W7D
LTE Band 4, CB: 10MHz	QPSK	0.406	9M01G7D
LTE Band 4, CB: 10MHz	16QAM	0.338	9M01W7D
LTE Band 4, CB: 15MHz	QPSK	0.419	13M5G7D
LTE Band 4, CB: 15MHz	16QAM	0.356	13M5W7D
LTE Band 4, CB: 20MHz	QPSK	0.410	18M0G7D
LTE Band 4, CB: 20MHz	16QAM	0.332	18M0W7D

1.1.3 Antenna Details

Ant. No.	Type	Gain (dBi)	Connector	Remark
1	Dipole	2	R-SMA	---

Note: The antenna is for testing use only.

1.1.4 EUT Operational Condition

Supply Voltage	3.7 Vdc from host		
Operational Voltage	<input checked="" type="checkbox"/> Vnom (3.7 V)	<input checked="" type="checkbox"/> Vmax (4.5 V)	<input checked="" type="checkbox"/> Vmin (3.2 V)
Operational Climatic	<input checked="" type="checkbox"/> Tnom (20°C)	<input checked="" type="checkbox"/> Tmax (55°C)	<input checked="" type="checkbox"/> Tmin (-20°C)

1.1.5 Operating Channel List

LTE Band 4		
Channel Bandwidth (MHz)	Channel	Frequency (MHz)
1.4	19957	1710.7
1.4	20175	1732.5
1.4	20393	1754.3
3	19965	1711.5
3	20175	1732.5
3	20385	1753.5
5	19975	1712.5
5	20175	1732.5
5	20375	1752.5
10	20000	1715.0
10	20175	1732.5
10	20350	1750.0
15	20025	1717.5
15	20175	1732.5
15	20325	1747.5
20	20050	1720.0
20	20175	1732.5
20	20300	1745.0

1.2 Local Support Equipment List

Support Equipment List						
No.	Equipment	Brand	Model	S/N	FCC ID	Signal cable / Length (m)
1	Power Supply	GWINSTEK	GPC-60300	EM884797	---	---

1.3 Test Setup Chart

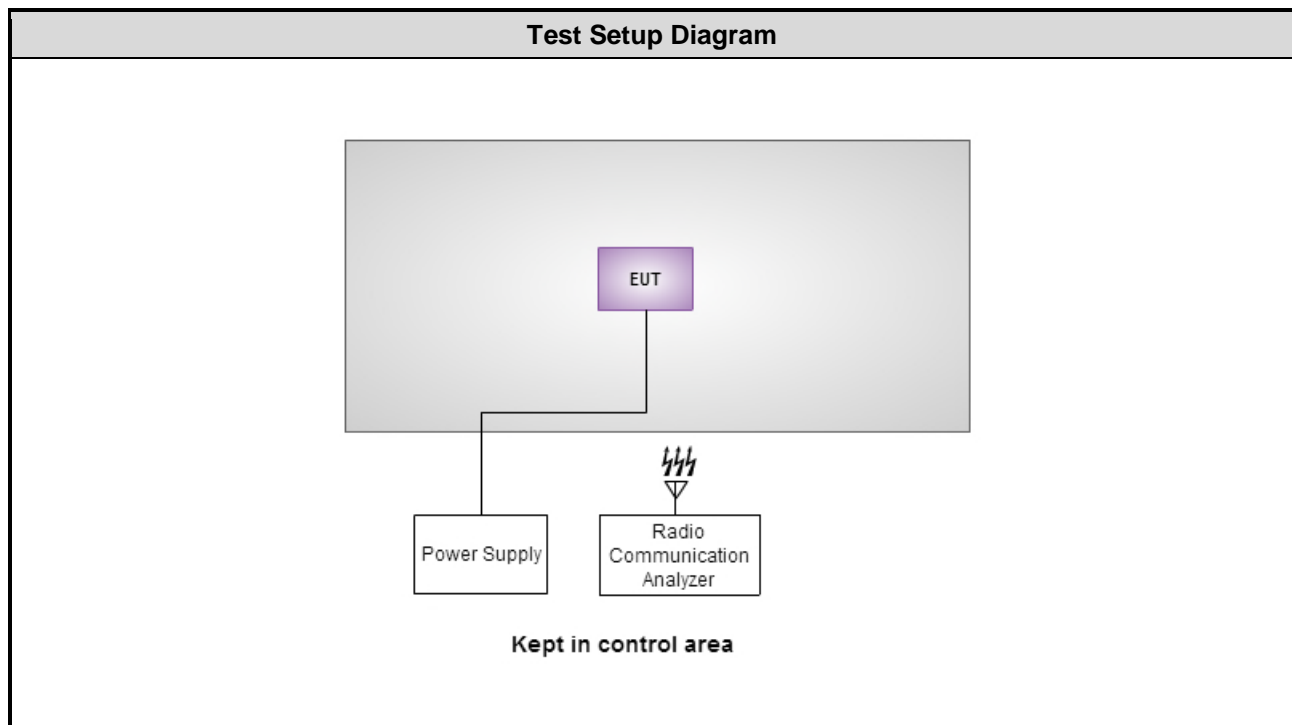

1.4 The Equipment List

Test Item	RF Conducted				
Test Site	(TH01-WS)				
Instrument	Manufacturer	Model No.	Serial No.	Calibration Date	Calibration Until
Spectrum Analyzer	R&S	FSV40	101063	Feb. 03, 2015	Feb. 02, 2016
TEMP&HUMIDITY CHAMBER	GIANT FORCE	GCT-225-40-SP-SD	MAF1212-002	Dec. 03, 2014	Dec. 02, 2015
Power Meter	Anritsu	ML2495A	1241002	Sep. 29, 2014	Sep. 28, 2015
Power Sensor	Anritsu	MA2411B	1207366	Sep. 29, 2014	Sep. 28, 2015
Radio Communication Analyzer	Anritsu	MT8820C	6201240341	Mar. 19, 2015	Mar. 17, 2016
Measurement Software	Sporton	Sporton_1	1.3.30	NA	NA

Note: Calibration Interval of instruments listed above is one year.

Test Item	Radiated Emission				
Test Site	966 chamber 2 / (03CH02-WS)				
Instrument	Manufacturer	Model No.	Serial No.	Calibration Date	Calibration Until
Spectrum Analyzer	R&S	FSV40	101499	Dec. 31, 2014	Dec. 30, 2015
Receiver	R&S	ESR3	101657	Jan. 15, 2015	Jan. 14, 2016
Bilog Antenna	SCHWARZBECK	VULB9168	VULB9168-524	Oct. 16, 2014	Oct. 15, 2015
Horn Antenna 1G-18G	SCHWARZBECK	BBHA 9120 D	BBHA 9120 D 1095	Oct. 14, 2014	Oct. 13, 2015
Horn Antenna 18G-40G	SCHWARZBECK	BBHA 9170	BBHA 9170517	Nov. 10, 2014	Nov. 09, 2015
Loop Antenna	R&S	HFH2-Z2	11900	Nov. 10, 2014	Nov. 09, 2015
Preamplifier	Burgeon	BPA-530	100218	Nov. 10, 2014	Nov. 09, 2015
Preamplifier	Agilent	83017A	MY39501309	Sep. 29, 2014	Sep. 28, 2015
Preamplifier	EMC	EMC184045B	980192	Aug. 26, 2014	Aug. 25, 2015
RF Cable	HUBER+SUHNER	SUCOFLEX104	MY16140/4	Dec. 16, 2014	Dec. 15, 2015
RF Cable	HUBER+SUHNER	SUCOFLEX104	MY16018/4	Dec. 16, 2014	Dec. 15, 2015
RF Cable	HUBER+SUHNER	SUCOFLEX104	MY16015/4	Dec. 16, 2014	Dec. 15, 2015
LF cable 3M	Woken	CFD400NL-LW	CFD400NL-003	Dec. 16, 2014	Dec. 15, 2015
LF cable 10M	Woken	CFD400NL-LW	CFD400NL-004	Dec. 16, 2014	Dec. 15, 2015
Measurement Software	AUDIX	e3	6.120210g	NA	NA

Note: Calibration Interval of instruments listed above is one year.

1.5 Test Standards

According to the specification of EUT, the EUT must comply with following standards.

47 CFR FCC Part 27 Subpart L

47 CFR FCC Part 2

ANSI C63.4-2003

ANSI / TIA / EIA-603-D -2010

KDB 971168 D01 Power Meas License Digital Systems v02r02

KDB 412172 D01 Determining ERP and EIRP v01r01

1.6 Measurement Uncertainty

ISO/IEC 17025 requires that an estimate of the measurement uncertainties associated with the emissions test results be included in the report. The measurement uncertainties given below are based on a 95% confidence level (based on a coverage factor (k=2))

Measurement Uncertainty	
Parameters	Uncertainty
Bandwidth	±34.134 Hz
Conducted power	±0.808 dB
Frequency error	±34.134 Hz
Temperature	±0.6 °C
Conducted emission	±2.670 dB
AC conducted emission	±2.92 dB
Radiated emission ≤ 1GHz	±3.62 dB
Radiated emission > 1GHz	±5.60 dB

2 Test Configuration

2.1 Testing Condition and Location Information

Test Item	Test Site	Ambient Condition	Tested By
RF conducted	TH01-WS	23°C / 64%	Felix Sung
Radiated Emissions	03CH02-WS	22°C / 64%	Anderson Hung

➤ FCC site registration No.: 657002

➤ IC site registration No.: 10807A-2

2.2 The Worst Test Modes and Channel Details

Test item	Channel Bandwidth	Modulation	Test channel
E.I.R.P	1.4 MHz	QPSK / 16QAM	19957 / 20175 / 20393
Conducted Emissions	3 MHz	QPSK / 16QAM	19965 / 20175 / 20385
Occupied Bandwidth	5 MHz	QPSK / 16QAM	19975 / 20175 / 20375
Peak to Average Ratio	10 MHz	QPSK / 16QAM	20000 / 20175 / 20350
	15 MHz	QPSK / 16QAM	20025 / 20175 / 20325
	20 MHz	QPSK / 16QAM	20050 / 20175 / 20300
Radiated Emission ≤ 1GHz	1.4 MHz	QPSK	20393
	3 MHz	QPSK	19965
	5 MHz	QPSK	20375
	10 MHz	QPSK	20350
	15 MHz	QPSK	20325
	20 MHz	QPSK	20050
Radiated Emission > 1GHz	1.4 MHz	QPSK	19957 / 20175 / 20393
	3 MHz	QPSK	19965 / 20175 / 20385
	5 MHz	QPSK	19975 / 20175 / 20375
	10 MHz	QPSK	20000 / 20175 / 20350
	15 MHz	QPSK	20025 / 20175 / 20325
	20 MHz	QPSK	20050 / 20175 / 20300
Band Edge	1.4 MHz	QPSK / 16QAM	19957 20393
	3 MHz	QPSK / 16QAM	19965 20385
	5 MHz	QPSK / 16QAM	19975 20375
	10 MHz	QPSK / 16QAM	20000 20350
	15 MHz	QPSK / 16QAM	20025 20325
	20 MHz	QPSK / 16QAM	20050 20300
Frequency Stability	1.4 MHz	QPSK	20175
	3 MHz	QPSK	20175
	5 MHz	QPSK	20175
	10 MHz	QPSK	20175
	15 MHz	QPSK	20175
	20 MHz	QPSK	20175

Note:

- The EUT was pretested with 3 orientations placed on the table for the radiated emission measurement – X, Y, and Z-plane. The **Y-plane** results were found as the worst case and were shown in this report.

3 Test Results

3.1 Equivalent Isotropically Radiated Power

3.1.1 Limit of Equivalent Isotropically Radiated Power

Mobile and portable stations are limited to 1 watts EIRP.

3.1.2 Test Procedures

For Conducted power measurement:

1. The EUT links up with simulator and is set to maximum output power level at low / middle / high channel.
2. Measure the output power of low / middle / high channel of the EUT.

For EIRP measurement:

EIPR can be calculated by below formula from KDB 412172 D01.

1. $EIRP = P_T + G_T - L_C$

P_T = transmitter output power, in dBm.

G_T = gain of the transmitting antenna, in dBi (EIRP).

L_C = signal attenuation in the connecting cable between the transmitter and antenna, in dB.

3.1.3 Test Setup

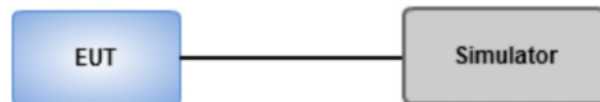

3.1.4 Test Result of Conducted power (dBm)

Band / Channel Bandwidth			LTE Band 4 / CB: 1.4MHz		
Channel			19957	20175	20393
Frequency (MHz)			1710.7	1732.5	1754.3
Mode	RB	RB Offset	Maximum AV Power (dBm)		
QPSK	1	0	23.65	23.56	24.08
	1	2	23.64	23.54	24.00
	1	5	23.59	23.64	24.00
	3	0	23.68	23.66	24.04
	3	1	23.65	23.78	24.05
	3	2	23.58	23.62	24.06
	6	0	23.66	22.64	22.91
16QAM	1	0	23.11	22.76	23.20
	1	2	22.85	22.72	23.34
	1	5	22.72	22.66	23.52
	3	0	22.59	22.54	23.06
	3	1	22.60	22.73	23.04
	3	2	22.76	22.64	23.06
	6	0	21.67	21.61	21.91

Band / Channel Bandwidth			LTE Band 4 / CB: 3MHz		
Channel			19965	20175	20385
Frequency (MHz)			1711.5	1732.5	1753.5
Mode	RB	RB Offset	Maximum AV Power (dBm)		
QPSK	1	0	23.66	23.62	23.53
	1	7	23.51	23.60	23.48
	1	14	23.62	23.59	23.52
	8	0	22.59	22.62	22.59
	8	4	22.58	22.65	22.62
	8	7	22.63	22.61	22.63
	15	0	22.54	22.58	22.51
16QAM	1	0	22.86	22.92	22.89
	1	7	22.86	22.83	22.76
	1	14	22.92	22.89	22.83
	8	0	21.49	21.56	21.46
	8	4	21.58	21.66	21.73
	8	7	21.55	21.65	21.59
	15	0	21.54	21.65	21.56

Band / Channel Bandwidth			LTE Band 4 / CB: 5MHz		
Channel			19975	20175	20375
Frequency (MHz)			1712.5	1732.5	1752.5
Mode	RB	RB Offset	Maximum AV Power (dBm)		
QPSK	1	0	23.66	23.63	23.99
	1	12	23.61	23.55	23.88
	1	24	23.60	23.72	23.91
	12	0	22.63	22.66	22.95
	12	6	22.57	22.56	22.95
	12	11	22.50	22.54	22.92
	25	0	22.53	22.62	22.94
16QAM	1	0	23.26	23.02	23.22
	1	12	22.68	22.87	23.03
	1	24	22.88	22.63	23.04
	12	0	21.70	21.82	22.11
	12	6	22.59	21.71	22.02
	12	11	21.61	21.58	21.99
	25	0	21.52	21.58	21.89

Band / Channel Bandwidth			LTE Band 4 / CB: 10MHz		
Channel			20000	20175	20350
Frequency (MHz)			1715.0	1732.5	1750.0
Mode	RB	RB Offset	Maximum AV Power (dBm)		
QPSK	1	0	23.87	23.96	24.09
	1	24	23.61	23.61	23.94
	1	49	23.50	23.64	23.88
	25	0	22.68	22.70	23.03
	25	12	22.53	22.58	22.95
	25	24	22.49	22.53	22.86
	50	0	22.58	22.64	22.92
16QAM	1	0	23.12	23.15	23.29
	1	24	22.86	22.79	23.17
	1	49	22.67	22.83	23.07
	25	0	21.71	21.74	22.06
	25	12	21.58	21.64	21.97
	25	24	21.50	21.59	21.93
	50	0	21.63	21.75	22.00

Band / Channel Bandwidth			LTE Band 4 / CB: 15MHz		
Channel			20025	20175	20325
Frequency (MHz)			1717.5	1732.5	1747.5
Mode	RB	RB Offset	Maximum AV Power (dBm)		
QPSK	1	0	23.96	24.10	24.22
	1	37	23.65	23.65	24.09
	1	74	23.39	23.49	23.77
	36	0	22.77	22.82	23.12
	36	18	22.55	22.68	22.90
	36	37	22.53	22.70	22.93
	75	0	22.65	22.83	23.02
16QAM	1	0	23.51	23.23	23.40
	1	37	23.22	23.08	23.27
	1	74	22.72	23.15	23.35
	36	0	21.82	21.94	22.20
	36	18	21.67	21.68	22.00
	36	37	21.60	21.63	21.90
	75	0	21.49	21.69	22.07

Band / Channel Bandwidth			LTE Band 4 / CB: 20MHz		
Channel			20050	20175	20300
Frequency (MHz)			1720.0	1732.5	1745.0
Mode	RB	RB Offset	Maximum AV Power (dBm)		
QPSK	1	0	24.13	23.73	23.91
	1	49	23.58	23.52	23.76
	1	99	23.37	23.18	23.54
	50	0	22.83	22.76	23.00
	50	24	22.52	22.62	22.78
	50	49	22.49	22.52	22.73
	100	0	22.67	22.68	22.88
16QAM	1	0	23.21	23.13	23.06
	1	49	22.90	22.75	23.01
	1	99	22.66	22.38	22.68
	50	0	21.85	21.67	22.01
	50	24	21.58	21.49	21.88
	50	49	21.53	21.45	21.70
	100	0	21.68	21.48	21.89

3.1.5 Test Result of Equivalent Isotropically Radiated Power (dBm)

Mode	LTE Band 4, CB: 1.4MHz, QPSK					
Channel	Frequency (MHz)	Conducted Output Power (dBm)	Max Antenna Gain (dBi)	EIRP (dBm)	EIRP (W)	Limit (dBm)
19957	1710.7	23.65	2	25.65	0.367	1
20175	1732.5	23.64	2	25.64	0.366	1
20393	1754.3	24.08	2	26.08	0.406	1

Mode	LTE Band 4, CB: 1.4MHz, 16QAM					
Channel	Frequency (MHz)	Conducted Output Power (dBm)	Max Antenna Gain (dBi)	EIRP (dBm)	EIRP (W)	Limit (dBm)
19957	1710.7	23.11	2	25.11	0.324	1
20175	1732.5	22.76	2	24.76	0.299	1
20393	1754.3	23.52	2	25.52	0.356	1

Mode	LTE Band 4, CB: 3MHz, QPSK					
Channel	Frequency (MHz)	Conducted Output Power (dBm)	Max Antenna Gain (dBi)	EIRP (dBm)	EIRP (W)	Limit (dBm)
19965	1711.5	23.66	2	25.66	0.368	1
20175	1732.5	23.62	2	25.62	0.365	1
20385	1753.5	23.53	2	25.53	0.357	1

Mode	LTE Band 4, CB: 3MHz, 16QAM					
Channel	Frequency (MHz)	Conducted Output Power (dBm)	Max Antenna Gain (dBi)	EIRP (dBm)	EIRP (W)	Limit (dBm)
19965	1711.5	22.92	2	24.92	0.310	1
20175	1732.5	22.92	2	24.92	0.310	1
20385	1753.5	22.89	2	24.89	0.308	1

Mode	LTE Band 4, CB: 5MHz, QPSK					
Channel	Frequency (MHz)	Conducted Output Power (dBm)	Max Antenna Gain (dBi)	EIRP (dBm)	EIRP (W)	Limit (dBm)
19975	1712.5	23.66	2	25.66	0.368	1
20175	1732.5	23.72	2	25.72	0.373	1
20375	1752.5	23.99	2	25.99	0.397	1

Mode	LTE Band 4, CB: 5MHz, 16QAM					
Channel	Frequency (MHz)	Conducted Output Power (dBm)	Max Antenna Gain (dBi)	EIRP (dBm)	EIRP (W)	Limit (dBm)
19975	1712.5	23.26	2	25.26	0.336	1
20175	1732.5	23.02	2	25.02	0.318	1
20375	1752.5	23.22	2	25.22	0.333	1

Mode	LTE Band 4, CB: 10MHz, QPSK					
Channel	Frequency (MHz)	Conducted Output Power (dBm)	Max Antenna Gain (dBi)	EIRP (dBm)	EIRP (W)	Limit (dBm)
20000	1715.0	23.87	2	25.87	0.386	1
20175	1732.5	23.96	2	25.96	0.394	1
20350	1750.0	24.09	2	26.09	0.406	1

Mode	LTE Band 4, CB: 10MHz, 16QAM					
Channel	Frequency (MHz)	Conducted Output Power (dBm)	Max Antenna Gain (dBi)	EIRP (dBm)	EIRP (W)	Limit (dBm)
20000	1715.0	23.12	2	25.12	0.325	1
20175	1732.5	23.15	2	25.15	0.327	1
20350	1750.0	23.29	2	25.29	0.338	1

Mode	LTE Band 4, CB: 15MHz, QPSK					
Channel	Frequency (MHz)	Conducted Output Power (dBm)	Max Antenna Gain (dBi)	EIRP (dBm)	EIRP (W)	Limit (dBm)
20025	1717.5	23.96	2	25.96	0.394	1
20175	1732.5	24.10	2	26.10	0.407	1
20325	1747.5	24.22	2	26.22	0.419	1

Mode	LTE Band 4, CB: 15MHz, 16QAM					
Channel	Frequency (MHz)	Conducted Output Power (dBm)	Max Antenna Gain (dBi)	EIRP (dBm)	EIRP (W)	Limit (dBm)
20025	1717.5	23.51	2	25.51	0.356	1
20175	1732.5	23.23	2	25.23	0.333	1
20325	1747.5	23.40	2	25.40	0.347	1

Mode	LTE Band 4, CB: 20MHz, QPSK					
Channel	Frequency (MHz)	Conducted Output Power (dBm)	Max Antenna Gain (dBi)	EIRP (dBm)	EIRP (W)	Limit (dBm)
20050	1720.0	24.13	2	26.13	0.410	1
20175	1732.5	23.73	2	25.73	0.374	1
20300	1745.0	23.91	2	25.91	0.390	1

Mode	LTE Band 4, CB: 20MHz, 16QAM					
Channel	Frequency (MHz)	Conducted Output Power (dBm)	Max Antenna Gain (dBi)	EIRP (dBm)	EIRP (W)	Limit (dBm)
20050	1720.0	23.21	2	25.21	0.332	1
20175	1732.5	23.13	2	25.13	0.326	1
20300	1745.0	23.06	2	25.06	0.321	1

3.2 Radiated Emissions

3.2.1 Limit of Radiated Emissions

The power of any emission outside of the authorized operating frequency ranges must be attenuated below the transmitting power (P) by a factor of at least $43 + 10 \log(P)$ dB equal to -13 dBm.

3.2.2 Test Procedures

1. Measurement is made at a semi-anechoic chamber that incorporates a turntable allowing a EUT rotation of 360° . A continuously-rotating, remotely-controlled turntable is installed at the test site to support the EUT and facilitate determination of the direction of maximum radiation for each EUT emission frequency. The EUT is placed at a height of 0.8 m test table above the ground plane.
2. Measurement is made with the antenna positioned in both the horizontal and vertical planes of polarization. The measurement antenna is varied in height (1m ~ 4m) above the reference ground plane to obtain the maximum signal strength. Distance between EUT and antenna is 3 m.
3. This investigation is performed with the EUT rotated 360° , the antenna height scanned between 1 m and 4 m, and the antenna rotated to repeat the measurements for both the horizontal and vertical antenna polarizations.
4. After finding the max radiated emission, substitution method will be used for getting effective radiated power. EUT will be removed and substitution antenna will be placed at same position. Signal generator will output CW signal to substitution antenna through a RF cable. Rotate turntable and move antenna to find maximum radiated emission. Adjust output power of signal generator to let the maximum radiated emission is same as step 3. Record the output power level.
5. E.I.R.P = output power of step 4 + gain of substitution antenna – cable loss of RF cable.

3.2.3 Test Setup

Radiated Emissions below 1 GHz

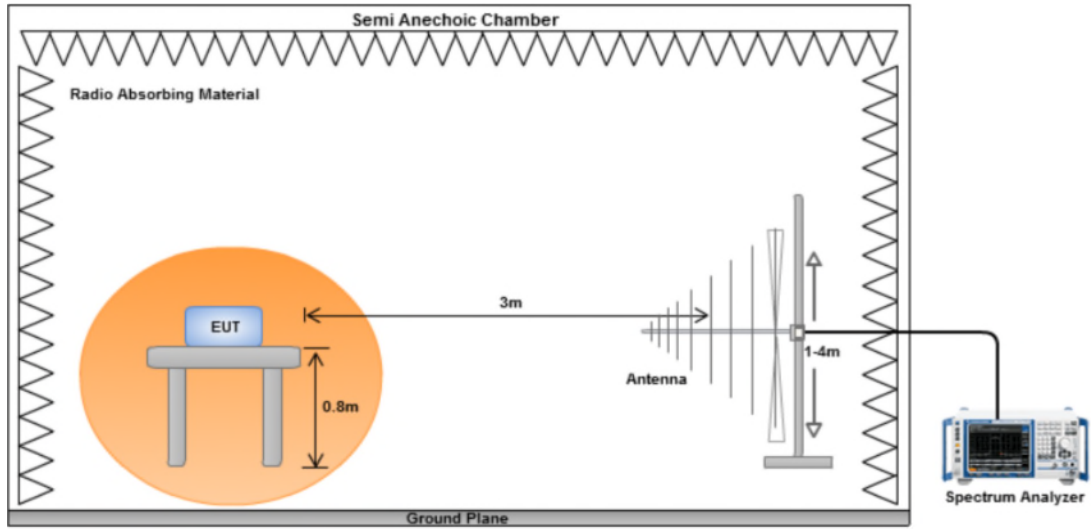

Radiated Emissions above 1 GHz

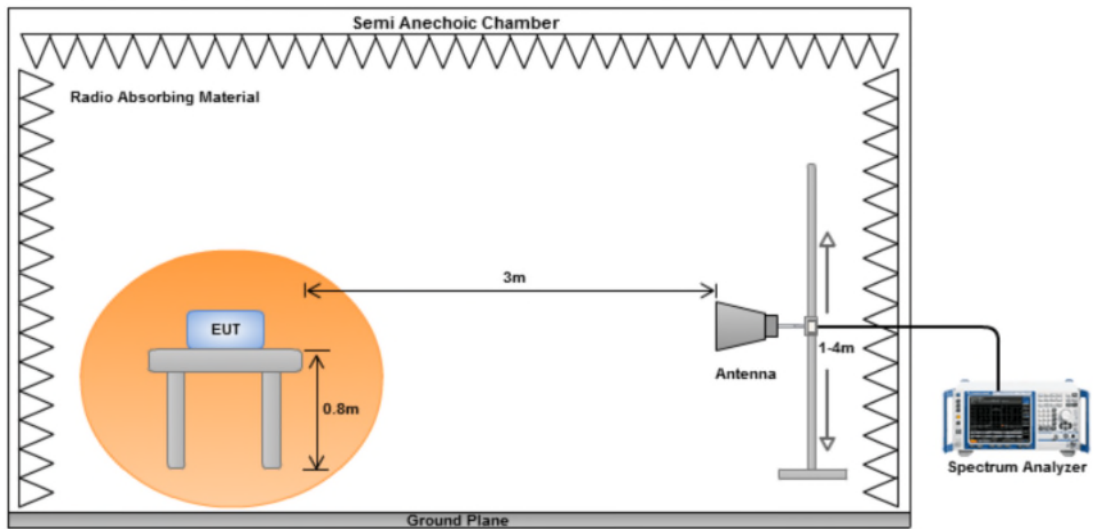

3.2.4 Test Result of Radiated Emissions below 1GHz

Mode							
LTE Band 4, CB: 1.4MHz, 1RB, Offset 0,Channel: 20393							
Frequency (MHz)	Antenna Polarity	E.I.R.P (dBm)	Limit (dBm)	Margin (dB)	S.A Reading (dBm)	S.G Power Vaule (dBm)	Correction Factor (dB)
38.73	H	-59.03	-13.00	-46.03	-61.86	-46.55	-12.48
107.60	H	-56.08	-13.00	-43.08	-49.01	-55.98	-0.10
128.94	H	-59.34	-13.00	-46.34	-52.90	-58.34	-1.00
189.08	H	-56.85	-13.00	-43.85	-48.71	-60.00	3.15
240.49	H	-66.16	-13.00	-53.16	-58.08	-70.53	4.37
743.92	H	-60.46	-13.00	-47.46	-63.62	-63.90	3.44
36.79	V	-46.16	-13.00	-33.16	-38.33	-33.41	-12.75
91.11	V	-51.88	-13.00	-38.88	-44.64	-52.32	0.44
143.49	V	-50.26	-13.00	-37.26	-46.79	-49.00	-1.26
220.12	V	-57.44	-13.00	-44.44	-53.99	-61.82	4.38
391.81	V	-62.18	-13.00	-49.18	-59.48	-66.49	4.31
730.34	V	-59.84	-13.00	-46.84	-64.06	-63.38	3.54

Note: EIRP = S.G Power value + Correction factor.

Mode							
LTE Band 4, CB: 3MHz, 1RB, Offset 0,Channel: 19965							
Frequency (MHz)	Antenna Polarity	E.I.R.P (dBm)	Limit (dBm)	Margin (dB)	S.A Reading (dBm)	S.G Power Vaule (dBm)	Correction Factor (dB)
36.79	H	-50.96	-13.00	-37.96	-53.71	-38.21	-12.75
106.63	H	-59.89	-13.00	-46.89	-52.84	-59.84	-0.05
127.00	H	-61.88	-13.00	-48.88	-55.22	-60.95	-0.93
175.50	H	-66.29	-13.00	-53.29	-59.66	-67.74	1.45
250.19	H	-68.61	-13.00	-55.61	-60.91	-72.98	4.37
341.37	H	-70.59	-13.00	-57.59	-66.94	-74.97	4.38
36.79	V	-48.91	-13.00	-35.91	-41.08	-36.16	-12.75
98.87	V	-53.87	-13.00	-40.87	-46.92	-54.16	0.29
143.49	V	-48.66	-13.00	-35.66	-45.19	-47.40	-1.26
243.40	V	-56.48	-13.00	-43.48	-53.41	-60.85	4.37
276.38	V	-60.04	-13.00	-47.04	-56.70	-64.32	4.28
419.94	V	-64.01	-13.00	-51.01	-61.69	-68.22	4.21

Note: EIRP = S.G Power value + Correction factor.

Mode							
LTE Band 4, CB: 5MHz, 1RB, Offset 0,Channel: 20375							
Frequency (MHz)	Antenna Polarity	E.I.R.P (dBm)	Limit (dBm)	Margin (dB)	S.A Reading (dBm)	S.G Power Vaule (dBm)	Correction Factor (dB)
39.70	H	-59.90	-13.00	-46.90	-62.77	-47.56	-12.34
97.90	H	-60.42	-13.00	-47.42	-53.58	-60.73	0.31
131.85	H	-65.63	-13.00	-52.63	-59.52	-64.54	-1.09
167.74	H	-66.17	-13.00	-53.17	-59.94	-66.46	0.29
186.17	H	-65.31	-13.00	-52.31	-57.57	-68.13	2.82
747.80	H	-59.72	-13.00	-46.72	-62.98	-63.13	3.41
42.61	V	-54.25	-13.00	-41.25	-46.98	-42.33	-11.92
93.05	V	-53.56	-13.00	-40.56	-46.35	-53.97	0.41
187.14	V	-54.91	-13.00	-41.91	-51.26	-57.84	2.93
243.40	V	-55.20	-13.00	-42.20	-52.13	-59.57	4.37
421.88	V	-66.74	-13.00	-53.74	-64.45	-70.94	4.20
729.37	V	-56.40	-13.00	-43.40	-60.62	-59.95	3.55

Note: EIRP = S.G Power value + Correction factor.

Mode							
LTE Band 4, CB: 10MHz, 1RB, Offset 0,Channel: 20350							
Frequency (MHz)	Antenna Polarity	E.I.R.P (dBm)	Limit (dBm)	Margin (dB)	S.A Reading (dBm)	S.G Power Vaule (dBm)	Correction Factor (dB)
37.76	H	-55.82	-13.00	-42.82	-58.61	-43.21	-12.61
98.87	H	-59.03	-13.00	-46.03	-52.19	-59.32	0.29
131.85	H	-61.56	-13.00	-48.56	-55.45	-60.47	-1.09
179.38	H	-61.75	-13.00	-48.75	-54.90	-63.78	2.03
447.10	H	-66.47	-13.00	-53.47	-64.33	-70.57	4.10
747.80	H	-62.02	-13.00	-49.02	-65.28	-65.43	3.41
36.79	V	-48.15	-13.00	-35.15	-40.32	-35.40	-12.75
97.90	V	-53.65	-13.00	-40.65	-46.65	-53.96	0.31
161.92	V	-51.61	-13.00	-38.61	-48.78	-51.04	-0.57
227.88	V	-60.80	-13.00	-47.80	-57.47	-65.18	4.38
386.96	V	-67.86	-13.00	-54.86	-65.11	-72.18	4.32
555.74	V	-63.25	-13.00	-50.25	-65.96	-67.35	4.10

Note: EIRP = S.G Power value + Correction factor.

Mode							
LTE Band 4, CB: 15MHz, 1RB, Offset 0,Channel: 20325							
Frequency (MHz)	Antenna Polarity	E.I.R.P (dBm)	Limit (dBm)	Margin (dB)	S.A Reading (dBm)	S.G Power Vaule (dBm)	Correction Factor (dB)
36.79	H	-58.19	-13.00	-45.19	-60.94	-45.44	-12.75
72.68	H	-59.78	-13.00	-46.78	-52.57	-55.25	-4.53
98.87	H	-58.86	-13.00	-45.86	-52.02	-59.15	0.29
171.62	H	-63.61	-13.00	-50.61	-57.18	-64.48	0.87
184.23	H	-59.58	-13.00	-46.58	-52.11	-62.18	2.60
747.80	H	-58.32	-13.00	-45.32	-61.58	-61.73	3.41
36.79	V	-47.51	-13.00	-34.51	-39.68	-34.76	-12.75
96.93	V	-53.52	-13.00	-40.52	-46.47	-53.85	0.33
150.28	V	-56.96	-13.00	-43.96	-53.79	-55.86	-1.10
226.91	V	-56.33	-13.00	-43.33	-52.99	-60.71	4.38
274.44	V	-65.38	-13.00	-52.38	-62.06	-69.67	4.29
610.06	V	-62.75	-13.00	-49.75	-66.11	-66.56	3.81

Note: EIRP = S.G Power value + Correction factor.

Mode							
LTE Band 4, CB: 20MHz, 1RB, Offset 0,Channel: 20050							
Frequency (MHz)	Antenna Polarity	E.I.R.P (dBm)	Limit (dBm)	Margin (dB)	S.A Reading (dBm)	S.G Power Vaule (dBm)	Correction Factor (dB)
36.79	H	-55.59	-13.00	-42.59	-58.34	-42.84	-12.75
98.87	H	-57.05	-13.00	-44.05	-50.21	-57.34	0.29
167.74	H	-62.31	-13.00	-49.31	-56.08	-62.60	0.29
262.80	H	-72.38	-13.00	-59.38	-65.04	-76.71	4.33
351.07	H	-69.89	-13.00	-56.89	-66.80	-74.31	4.42
441.28	H	-68.99	-13.00	-55.99	-66.74	-73.11	4.12
42.61	V	-53.08	-13.00	-40.08	-45.81	-41.16	-11.92
97.90	V	-54.17	-13.00	-41.17	-47.17	-54.48	0.31
130.88	V	-47.01	-13.00	-34.01	-43.20	-45.95	-1.06
165.80	V	-55.71	-13.00	-42.71	-52.72	-55.71	0.00
221.09	V	-58.10	-13.00	-45.10	-54.67	-62.48	4.38
285.11	V	-57.72	-13.00	-44.72	-54.25	-61.97	4.25

Note: EIRP = S.G Power value + Correction factor.

3.2.5 Test Result of Radiated Emissions above 1GHz

Mode							
LTE Band 4, CB:1.4MHz, 1RB, Offset 0,Channel:19957							
Frequency (MHz)	Antenna Polarity	E.I.R.P (dBm)	Limit (dBm)	Margin (dB)	S.A Reading (dBm)	S.G Power Vaule (dBm)	Correction Factor (dB)
3420.40	H	-49.57	-13.00	-36.57	-60.97	-56.12	6.55
5131.00	H	-45.22	-13.00	-32.22	-63.10	-51.06	5.84
6841.50	H	-40.43	-13.00	-27.43	-60.96	-44.08	3.65
3420.40	V	-49.54	-13.00	-36.54	-61.31	-56.09	6.55
5131.00	V	-45.40	-13.00	-32.40	-62.13	-51.24	5.84
6841.50	V	-37.36	-13.00	-24.36	-56.88	-41.01	3.65

Mode							
LTE Band 4, CB: 1.4MHz, 1RB, Offset 0, Channel : 20175							
Frequency (MHz)	Antenna Polarity	E.I.R.P (dBm)	Limit (dBm)	Margin (dB)	S.A Reading (dBm)	S.G Power Vaule (dBm)	Correction Factor (dB)
3463.80	H	-43.55	-13.00	-30.55	-55.39	-50.11	6.56
5196.10	H	-46.87	-13.00	-33.87	-65.01	-52.71	5.84
6928.40	H	-42.78	-13.00	-29.78	-63.36	-46.36	3.58
3463.80	V	-47.87	-13.00	-34.87	-59.89	-54.43	6.56
5196.10	V	-45.63	-13.00	-32.63	-62.60	-51.47	5.84
6928.40	V	-39.24	-13.00	-26.24	-59.28	-42.82	3.58

Mode							
LTE Band 4, CB: 1.4MHz, 1RB, Offset 0, Channel : 20393							
Frequency (MHz)	Antenna Polarity	E.I.R.P (dBm)	Limit (dBm)	Margin (dB)	S.A Reading (dBm)	S.G Power Vaule (dBm)	Correction Factor (dB)
3507.20	H	-50.11	-13.00	-37.11	-62.41	-56.68	6.57
5261.20	H	-45.02	-13.00	-32.02	-62.75	-50.88	5.86
7015.20	H	-43.32	-13.00	-30.32	-64.05	-46.78	3.46
3507.20	V	-50.45	-13.00	-37.45	-62.73	-57.02	6.57
5261.20	V	-42.42	-13.00	-29.42	-59.24	-48.28	5.86
7015.20	V	-38.69	-13.00	-25.69	-59.27	-42.15	3.46

Note: EIRP = S.G Power value + Correction factor.

Mode							
LTE Band 4, CB: 3MHz, 1RB, Offset 0, Channel : 19965							
Frequency (MHz)	Antenna Polarity	E.I.R.P (dBm)	Limit (dBm)	Margin (dB)	S.A Reading (dBm)	S.G Power Vaule (dBm)	Correction Factor (dB)
3420.40	H	-49.96	-13.00	-36.96	-61.36	-56.51	6.55
5131.00	H	-45.18	-13.00	-32.18	-63.06	-51.02	5.84
6841.50	H	-40.45	-13.00	-27.45	-60.98	-44.10	3.65
3420.40	V	-49.56	-13.00	-36.56	-61.33	-56.11	6.55
5131.00	V	-45.38	-13.00	-32.38	-62.11	-51.22	5.84
6841.50	V	-37.42	-13.00	-24.42	-56.94	-41.07	3.65

Mode							
LTE Band 4, CB: 3MHz, 1RB, Offset 0, Channel : 20175							
Frequency (MHz)	Antenna Polarity	E.I.R.P (dBm)	Limit (dBm)	Margin (dB)	S.A Reading (dBm)	S.G Power Vaule (dBm)	Correction Factor (dB)
3462.40	H	-43.07	-13.00	-30.07	-54.90	-49.63	6.56
5193.20	H	-46.88	-13.00	-33.88	-65.00	-52.72	5.84
6925.50	H	-42.37	-13.00	-29.37	-62.95	-45.95	3.58
3462.40	V	-48.39	-13.00	-35.39	-60.41	-54.95	6.56
5193.20	V	-46.42	-13.00	-33.42	-63.38	-52.26	5.84
6925.50	V	-39.27	-13.00	-26.27	-59.29	-42.85	3.58

Mode							
LTE Band 4, CB: 3MHz, 1RB, Offset 0, Channel : 20385							
Frequency (MHz)	Antenna Polarity	E.I.R.P (dBm)	Limit (dBm)	Margin (dB)	S.A Reading (dBm)	S.G Power Vaule (dBm)	Correction Factor (dB)
3504.30	H	-50.18	-13.00	-37.18	-62.44	-56.75	6.57
5256.90	H	-45.45	-13.00	-32.45	-63.21	-51.31	5.86
7009.40	H	-43.27	-13.00	-30.27	-63.96	-46.75	3.48
3504.30	V	-51.08	-13.00	-38.08	-63.34	-57.65	6.57
5256.90	V	-41.89	-13.00	-28.89	-58.73	-47.75	5.86
7009.40	V	-38.62	-13.00	-25.62	-59.16	-42.10	3.48

Note: EIRP = S.G Power value + Correction factor.

Mode							
LTE Band 4, CB: 5MHz, 1RB, Offset 0, Channel : 19975							
Frequency (MHz)	Antenna Polarity	E.I.R.P (dBm)	Limit (dBm)	Margin (dB)	S.A Reading (dBm)	S.G Power Vaule (dBm)	Correction Factor (dB)
3420.40	H	-49.96	-13.00	-36.96	-61.36	-56.51	6.55
5131.00	H	-45.39	-13.00	-32.39	-63.27	-51.23	5.84
6841.50	H	-40.51	-13.00	-27.51	-61.04	-44.16	3.65
3420.40	V	-49.56	-13.00	-36.56	-61.33	-56.11	6.55
5131.00	V	-45.27	-13.00	-32.27	-62.00	-51.11	5.84
6841.50	V	-37.47	-13.00	-24.47	-56.99	-41.12	3.65

Mode							
LTE Band 4, CB: 5MHz, 1RB, Offset 0, Channel : 20175							
Frequency (MHz)	Antenna Polarity	E.I.R.P (dBm)	Limit (dBm)	Margin (dB)	S.A Reading (dBm)	S.G Power Vaule (dBm)	Correction Factor (dB)
3460.90	H	-43.01	-13.00	-30.01	-54.82	-49.57	6.56
5190.30	H	-46.34	-13.00	-33.34	-64.45	-52.18	5.84
6921.10	H	-42.75	-13.00	-29.75	-63.33	-46.34	3.59
3460.90	V	-47.66	-13.00	-34.66	-59.67	-54.22	6.56
5190.30	V	-46.37	-13.00	-33.37	-63.32	-52.21	5.84
6921.10	V	-39.14	-13.00	-26.14	-59.13	-42.73	3.59

Mode							
LTE Band 4, CB: 5MHz, 1RB, Offset 0, Channel : 20375							
Frequency (MHz)	Antenna Polarity	E.I.R.P (dBm)	Limit (dBm)	Margin (dB)	S.A Reading (dBm)	S.G Power Vaule (dBm)	Correction Factor (dB)
3500.00	H	-50.19	-13.00	-37.19	-62.41	-56.76	6.57
5251.10	H	-45.06	-13.00	-32.06	-62.86	-50.92	5.86
7000.70	H	-43.12	-13.00	-30.12	-63.75	-46.64	3.52
3500.00	V	-50.46	-13.00	-37.46	-62.70	-57.03	6.57
5251.10	V	-42.39	-13.00	-29.39	-59.24	-48.25	5.86
7000.70	V	-38.63	-13.00	-25.63	-59.10	-42.15	3.52

Note: EIRP = S.G Power value + Correction factor.

Mode							
LTE Band 4, CB: 10MHz, 1RB, Offset 0, Channel : 20000							
Frequency (MHz)	Antenna Polarity	E.I.R.P (dBm)	Limit (dBm)	Margin (dB)	S.A Reading (dBm)	S.G Power Vaule (dBm)	Correction Factor (dB)
3420.40	H	-49.97	-13.00	-36.97	-61.37	-56.52	6.55
5131.00	H	-45.33	-13.00	-32.33	-63.21	-51.17	5.84
6843.00	H	-40.56	-13.00	-27.56	-61.09	-44.21	3.65
3420.40	V	-49.42	-13.00	-36.42	-61.19	-55.97	6.55
5131.00	V	-45.39	-13.00	-32.39	-62.12	-51.23	5.84
6843.00	V	-37.36	-13.00	-24.36	-56.89	-41.01	3.65

Mode							
LTE Band 4, CB: 10MHz, 1RB, Offset 0, Channel : 20175							
Frequency (MHz)	Antenna Polarity	E.I.R.P (dBm)	Limit (dBm)	Margin (dB)	S.A Reading (dBm)	S.G Power Vaule (dBm)	Correction Factor (dB)
3456.60	H	-43.12	-13.00	-30.12	-54.89	-49.68	6.56
5184.50	H	-46.37	-13.00	-33.37	-64.46	-52.21	5.84
6912.40	H	-42.45	-13.00	-29.45	-63.02	-46.04	3.59
3456.60	V	-47.78	-13.00	-34.78	-59.77	-54.34	6.56
5184.50	V	-46.34	-13.00	-33.34	-63.27	-52.18	5.84
6912.40	V	-39.21	-13.00	-26.21	-59.15	-42.80	3.59

Mode							
LTE Band 4, CB: 10MHz, 1RB, Offset 0, Channel : 20350							
Frequency (MHz)	Antenna Polarity	E.I.R.P (dBm)	Limit (dBm)	Margin (dB)	S.A Reading (dBm)	S.G Power Vaule (dBm)	Correction Factor (dB)
3491.30	H	-50.13	-13.00	-37.13	-62.26	-56.70	6.57
5236.60	H	-45.54	-13.00	-32.54	-63.44	-51.39	5.85
6981.90	H	-43.26	-13.00	-30.26	-63.87	-46.80	3.54
3491.30	V	-50.34	-13.00	-37.34	-62.52	-56.91	6.57
5236.60	V	-42.36	-13.00	-29.36	-59.24	-48.21	5.85
6981.90	V	-38.39	-13.00	-25.39	-58.74	-41.93	3.54

Note: EIRP = S.G Power value + Correction factor.

Mode							
LTE Band 4, CB: 15MHz, 1RB, Offset 0, Channel : 20025							
Frequency (MHz)	Antenna Polarity	E.I.R.P (dBm)	Limit (dBm)	Margin (dB)	S.A Reading (dBm)	S.G Power Vaule (dBm)	Correction Factor (dB)
3421.50	H	-49.83	-13.00	-36.83	-61.25	-56.38	6.55
5132.50	H	-45.04	-13.00	-32.04	-62.92	-50.88	5.84
6843.20	H	-40.20	-13.00	-27.20	-60.73	-43.85	3.65
3421.50	V	-49.31	-13.00	-36.31	-61.10	-55.86	6.55
5132.50	V	-45.11	-13.00	-32.11	-61.84	-50.95	5.84
6843.20	V	-37.20	-13.00	-24.20	-56.73	-40.85	3.65

Mode							
LTE Band 4, CB: 15MHz, 1RB, Offset 0, Channel : 20175							
Frequency (MHz)	Antenna Polarity	E.I.R.P (dBm)	Limit (dBm)	Margin (dB)	S.A Reading (dBm)	S.G Power Vaule (dBm)	Correction Factor (dB)
3451.60	H	-43.35	-13.00	-30.35	-55.08	-49.91	6.56
5177.50	H	-46.70	-13.00	-33.70	-64.76	-52.54	5.84
6903.20	H	-42.90	-13.00	-29.90	-63.47	-46.50	3.60
3451.60	V	-48.00	-13.00	-35.00	-59.96	-54.56	6.56
5177.50	V	-46.07	-13.00	-33.07	-62.97	-51.91	5.84
6903.20	V	-39.07	-13.00	-26.07	-58.96	-42.67	3.60

Mode							
LTE Band 4, CB: 15MHz, 1RB, Offset 0, Channel : 20325							
Frequency (MHz)	Antenna Polarity	E.I.R.P (dBm)	Limit (dBm)	Margin (dB)	S.A Reading (dBm)	S.G Power Vaule (dBm)	Correction Factor (dB)
3481.70	H	-50.34	-13.00	-37.34	-62.37	-56.90	6.56
5222.40	H	-45.28	-13.00	-32.28	-63.27	-51.13	5.85
6963.30	H	-43.63	-13.00	-30.63	-64.23	-47.18	3.55
3481.70	V	-50.78	-13.00	-37.78	-62.91	-57.34	6.56
5222.40	V	-42.11	-13.00	-29.11	-59.03	-47.96	5.85
6963.30	V	-38.75	-13.00	-25.75	-58.99	-42.30	3.55

Note: EIRP = S.G Power value + Correction factor.

Mode							
LTE Band 4, CB: 20MHz, 1RB, Offset 0, Channel : 20050							
Frequency (MHz)	Antenna Polarity	E.I.R.P (dBm)	Limit (dBm)	Margin (dB)	S.A Reading (dBm)	S.G Power Vaule (dBm)	Correction Factor (dB)
3421.90	H	-49.68	-13.00	-36.68	-61.10	-56.23	6.55
5133.90	H	-45.17	-13.00	-32.17	-63.06	-51.01	5.84
6844.40	H	-40.37	-13.00	-27.37	-60.91	-44.02	3.65
3421.90	V	-49.62	-13.00	-36.62	-61.41	-56.17	6.55
5133.90	V	-45.27	-13.00	-32.27	-62.01	-51.11	5.84
6844.40	V	-37.44	-13.00	-24.44	-56.98	-41.09	3.65

Mode							
LTE Band 4, CB: 20MHz, 1RB, Offset 0, Channel : 20175							
Frequency (MHz)	Antenna Polarity	E.I.R.P (dBm)	Limit (dBm)	Margin (dB)	S.A Reading (dBm)	S.G Power Vaule (dBm)	Correction Factor (dB)
3446.50	H	-43.08	-13.00	-30.08	-54.75	-49.63	6.55
5171.50	H	-46.28	-13.00	-33.28	-64.32	-52.12	5.84
6893.60	H	-42.74	-13.00	-29.74	-63.30	-46.35	3.61
3446.50	V	-48.32	-13.00	-35.32	-60.24	-54.87	6.55
5171.50	V	-46.28	-13.00	-33.28	-63.16	-52.12	5.84
6893.60	V	-39.16	-13.00	-26.16	-58.99	-42.77	3.61

Mode							
LTE Band 4, CB: 20MHz, 1RB, Offset 0, Channel : 20300							
Frequency (MHz)	Antenna Polarity	E.I.R.P (dBm)	Limit (dBm)	Margin (dB)	S.A Reading (dBm)	S.G Power Vaule (dBm)	Correction Factor (dB)
3472.50	H	-50.11	-13.00	-37.11	-62.05	-56.67	6.56
5209.10	H	-45.24	-13.00	-32.24	-63.33	-51.08	5.84
6944.30	H	-43.19	-13.00	-30.19	-63.78	-46.76	3.57
3472.50	V	-50.69	-13.00	-37.69	-62.77	-57.25	6.56
5209.10	V	-42.18	-13.00	-29.18	-59.14	-48.02	5.84
6944.30	V	-38.56	-13.00	-25.56	-58.69	-42.13	3.57

Note: EIRP = S.G Power value + Correction factor.

3.3 Conducted Emissions

3.3.1 Limit of Conducted Emissions

The power of any emission outside of the authorized operating frequency ranges must be attenuated below the transmitting power (P) by a factor of at least $43 + 10 \log(P)$ dB equal to -13dBm.

3.3.2 Test Procedures

1. Lowest, middle and highest operating channels are tested for this item.
2. Scan frequency range is from 30 MHz~19.1 GHz.
3. Set RBW = 1MHz, VBW = 3MHz, detector =Peak, sweep time = auto.
4. Record the max trace value and capture the test plot of each sub frequency band.

3.3.3 Test Setup

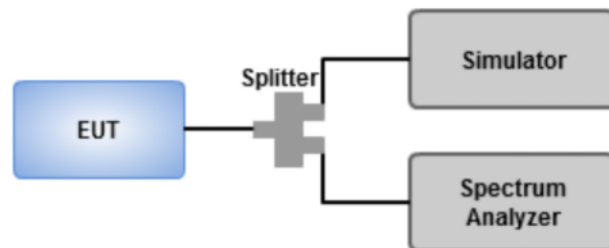

3.3.4 Test Result of Conducted Emissions

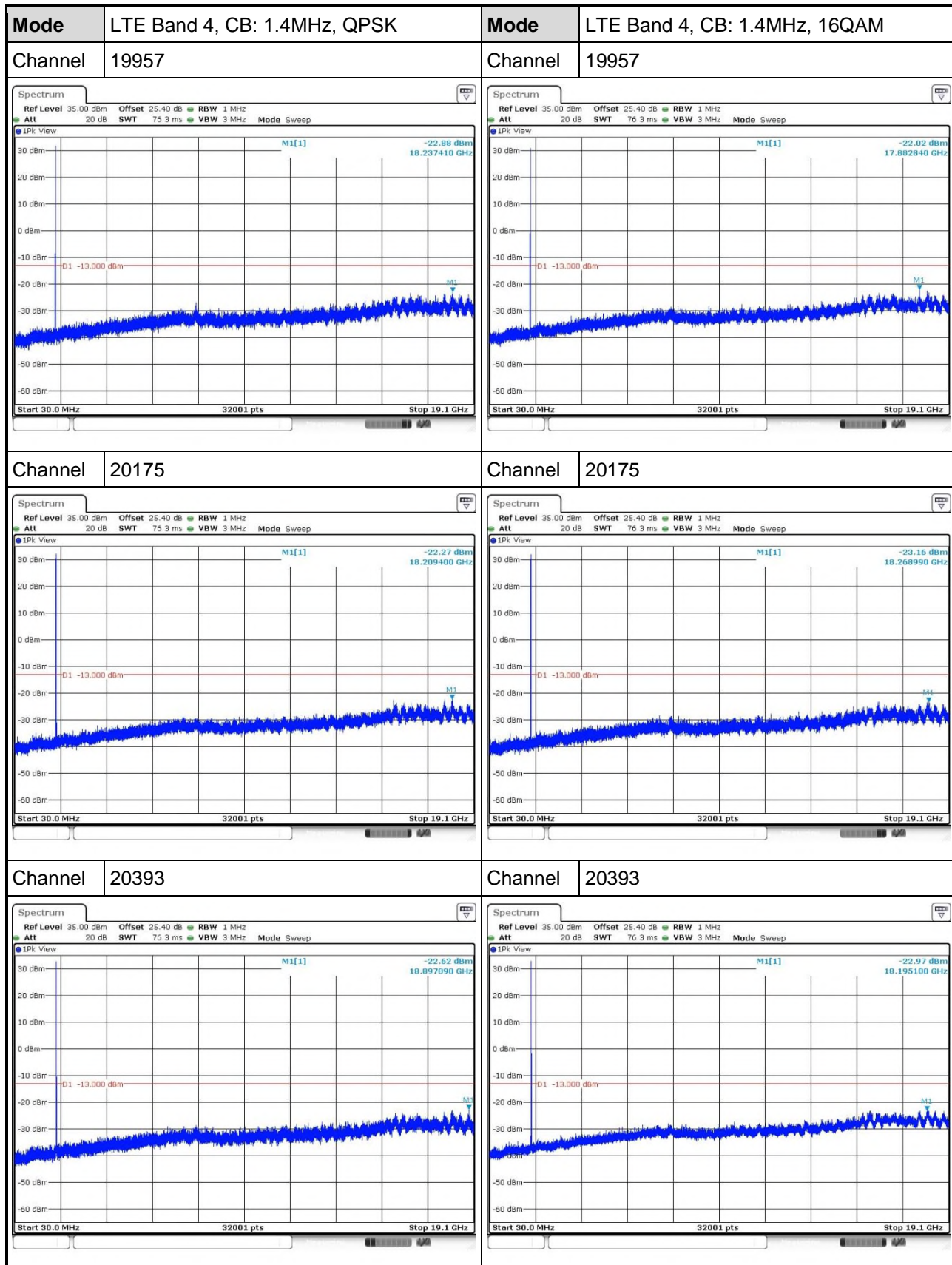

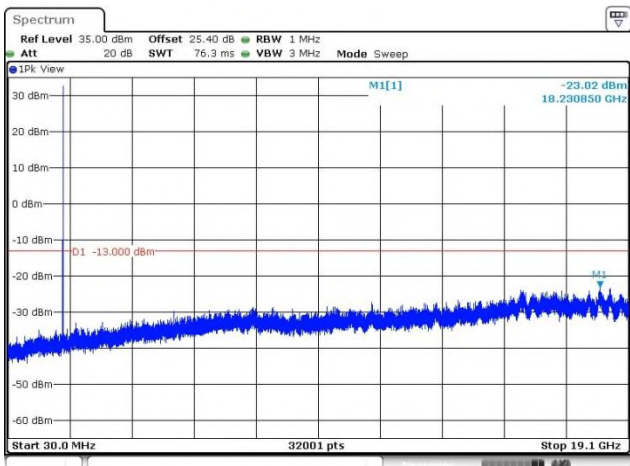
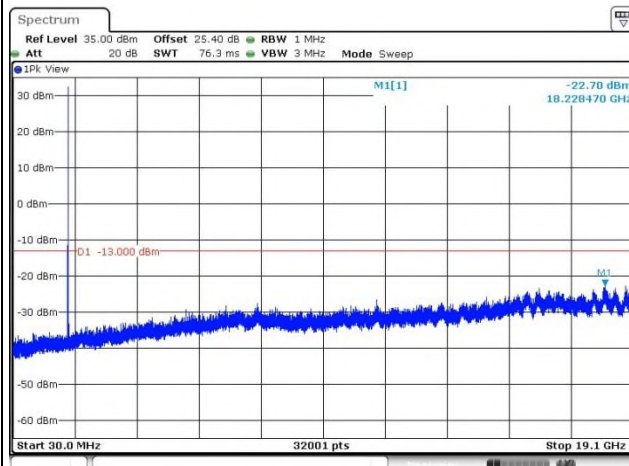
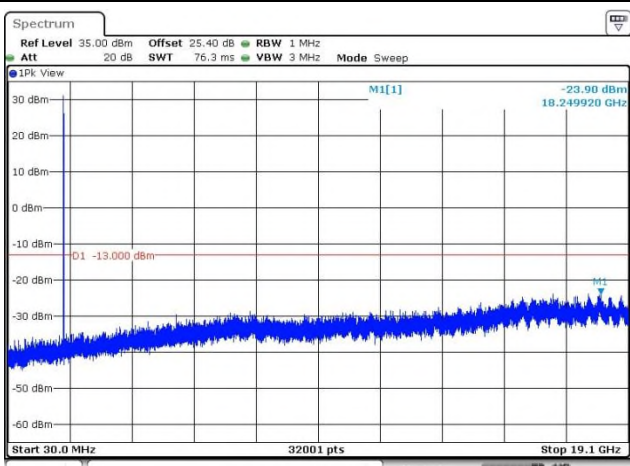
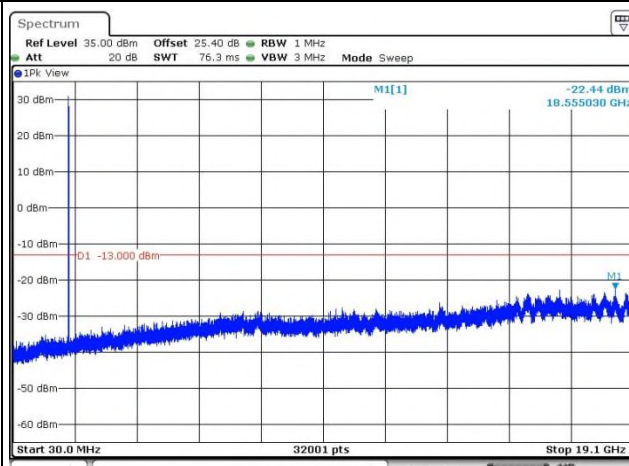
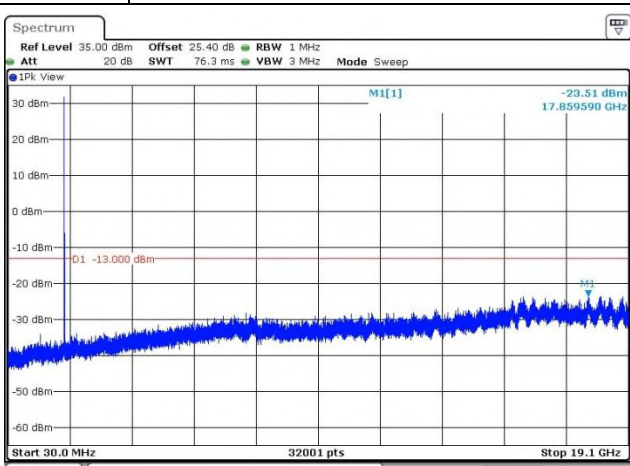
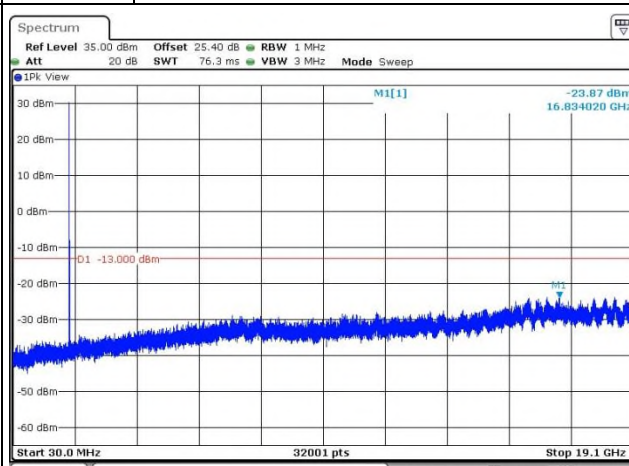
Mode	LTE Band 4, CB: 3MHz, QPSK	Mode	LTE Band 4, CB: 3MHz, 16QAM
Channel	19965	Channel	19965
			
Channel	20175	Channel	20175
			
Channel	20385	Channel	20385
			

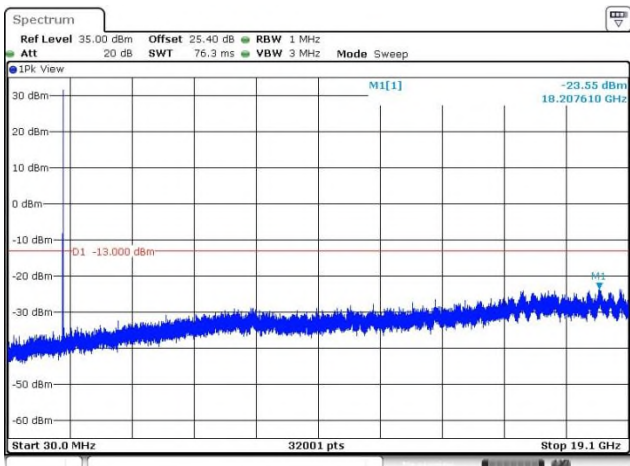
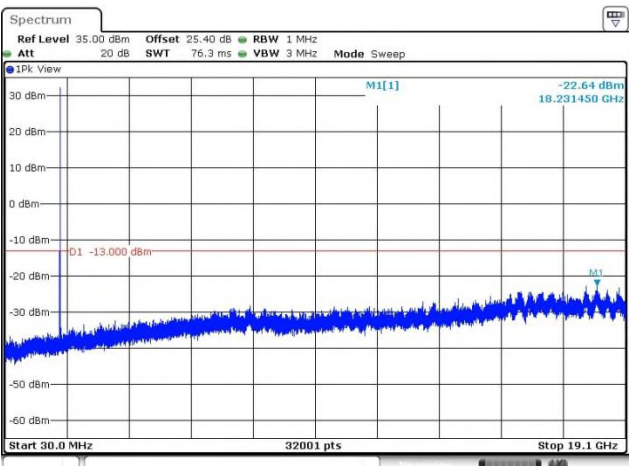
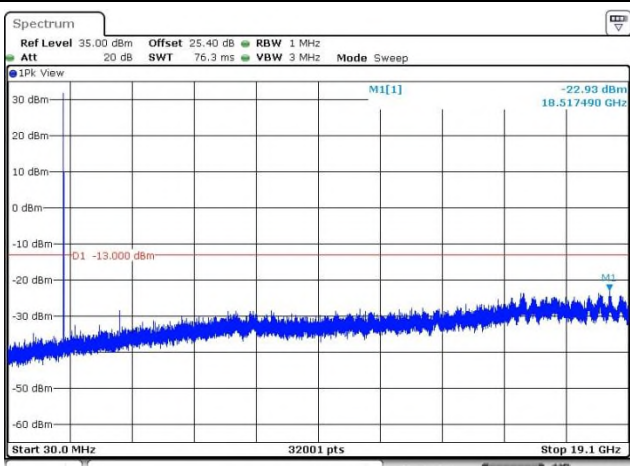
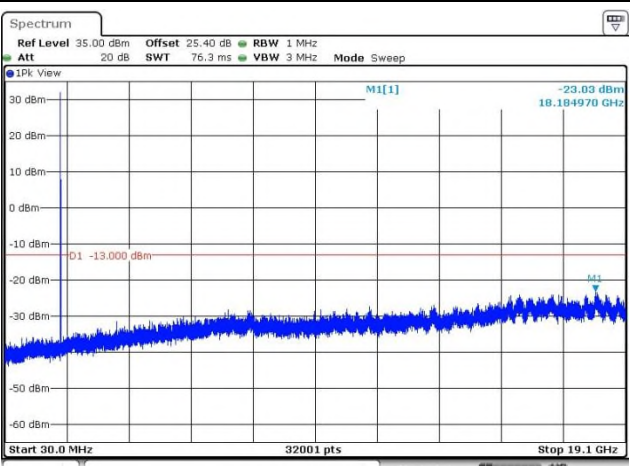
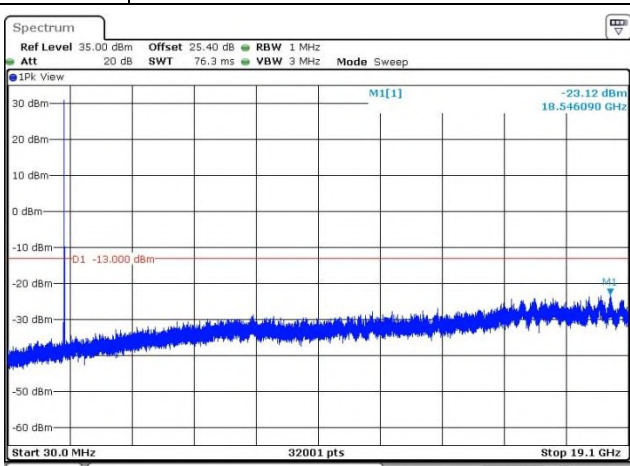
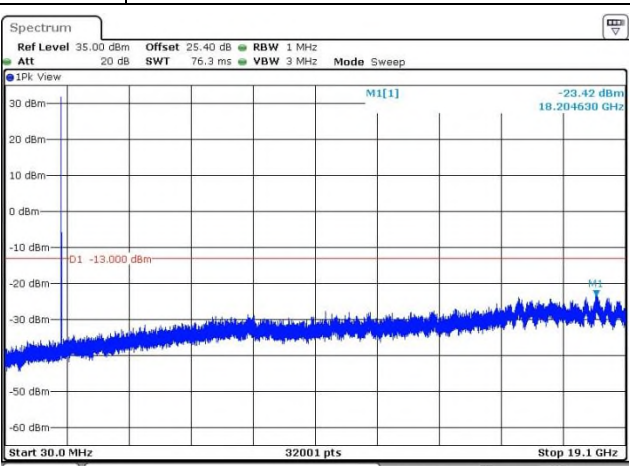
Mode	LTE Band 4, CB: 5MHz, QPSK	Mode	LTE Band 4, CB: 5MHz, 16QAM
Channel	19975	Channel	19975
			
Channel	20175	Channel	20175
			
Channel	20375	Channel	20375
			

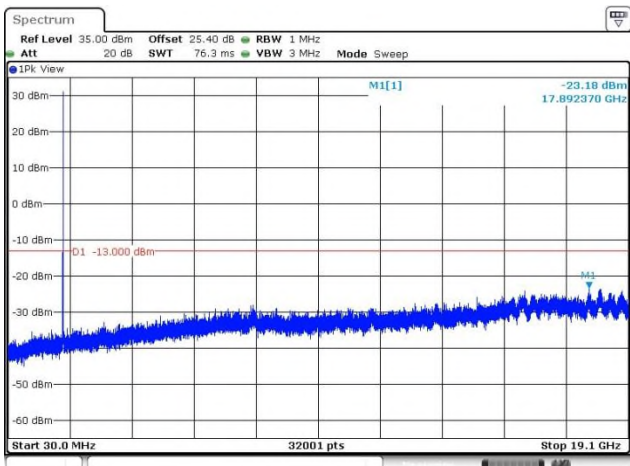
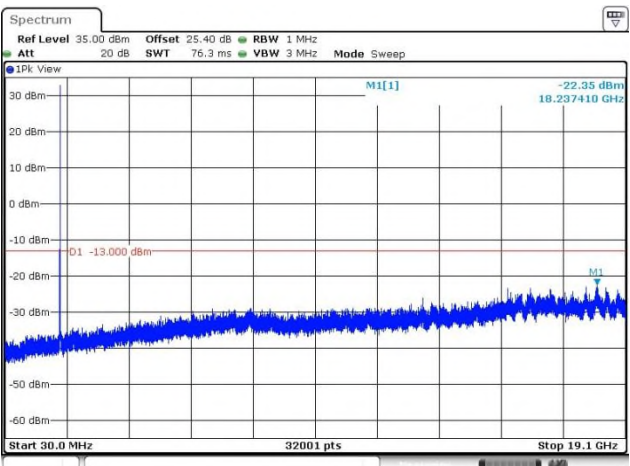
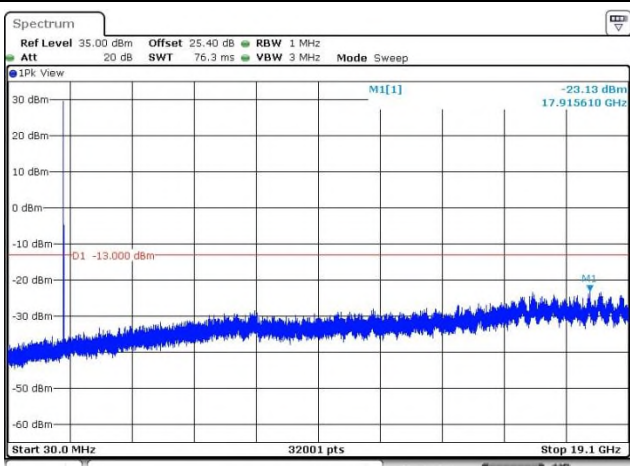
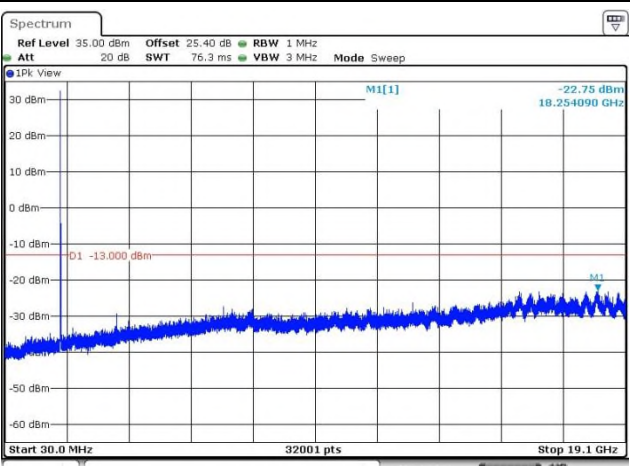
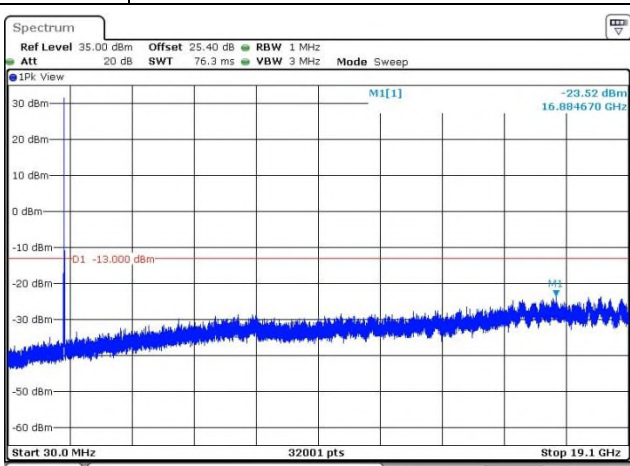
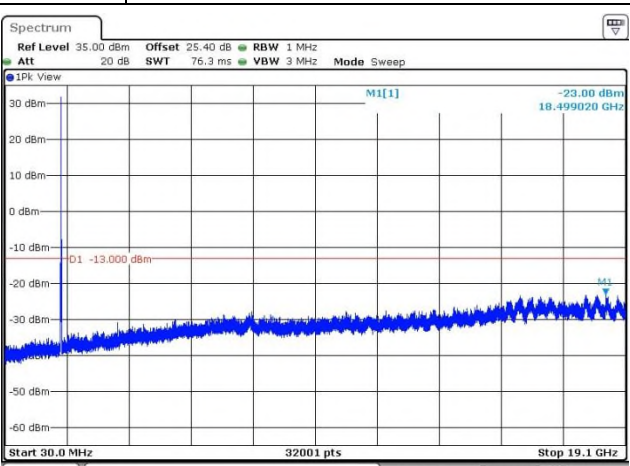
Mode	LTE Band 4, CB: 10MHz, QPSK	Mode	LTE Band 4, CB: 10MHz, 16QAM
Channel	20000	Channel	20000
 <p>Spectrum Ref Level 35.00 dBm Offset 25.40 dB RBW 1 MHz Att 20 dB SWT 76.3 ms VBW 3 MHz Mode Sweep 1PK View M1[1] -23.18 dBm 17.892370 GHz D1 -13.000 dBm Start 30.0 MHz 32001 pts Stop 19.1 GHz</p>		 <p>Spectrum Ref Level 35.00 dBm Offset 25.40 dB RBW 1 MHz Att 20 dB SWT 76.3 ms VBW 3 MHz Mode Sweep 1PK View M1[1] -22.35 dBm 18.237410 GHz D1 -13.000 dBm Start 30.0 MHz 32001 pts Stop 19.1 GHz</p>	
Channel	20175	Channel	20175
 <p>Spectrum Ref Level 35.00 dBm Offset 25.40 dB RBW 1 MHz Att 20 dB SWT 76.3 ms VBW 3 MHz Mode Sweep 1PK View M1[1] -23.13 dBm 17.915610 GHz D1 -13.000 dBm Start 30.0 MHz 32001 pts Stop 19.1 GHz</p>		 <p>Spectrum Ref Level 35.00 dBm Offset 25.40 dB RBW 1 MHz Att 20 dB SWT 76.3 ms VBW 3 MHz Mode Sweep 1PK View M1[1] -22.75 dBm 18.254090 GHz D1 -13.000 dBm Start 30.0 MHz 32001 pts Stop 19.1 GHz</p>	
Channel	20350	Channel	20350
 <p>Spectrum Ref Level 35.00 dBm Offset 25.40 dB RBW 1 MHz Att 20 dB SWT 76.3 ms VBW 3 MHz Mode Sweep 1PK View M1[1] -23.52 dBm 16.884670 GHz D1 -13.000 dBm Start 30.0 MHz 32001 pts Stop 19.1 GHz</p>		 <p>Spectrum Ref Level 35.00 dBm Offset 25.40 dB RBW 1 MHz Att 20 dB SWT 76.3 ms VBW 3 MHz Mode Sweep 1PK View M1[1] -23.00 dBm 18.499020 GHz D1 -13.000 dBm Start 30.0 MHz 32001 pts Stop 19.1 GHz</p>	

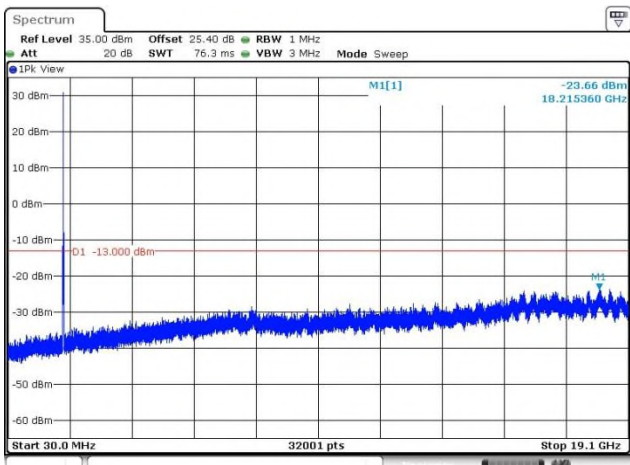
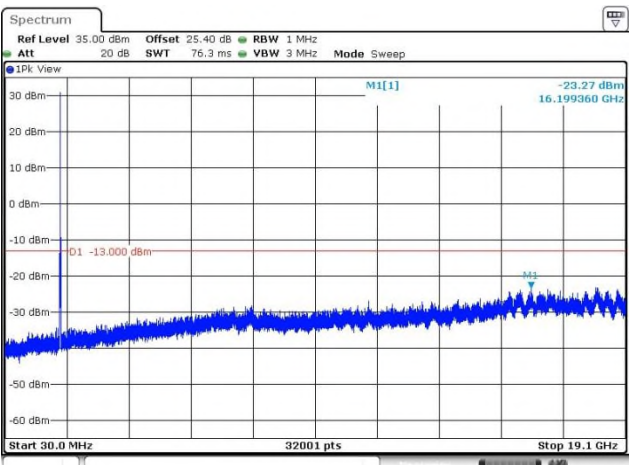
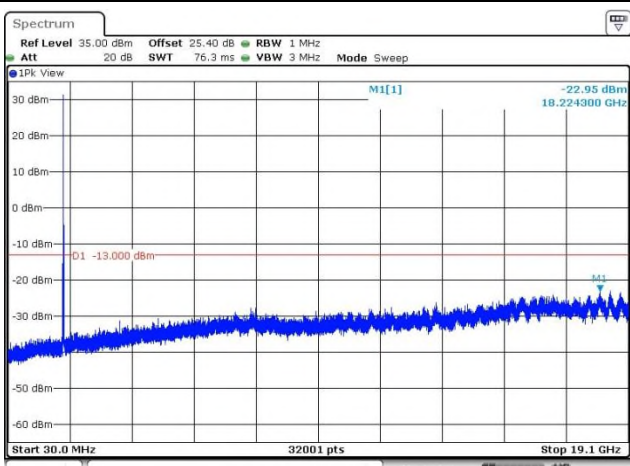
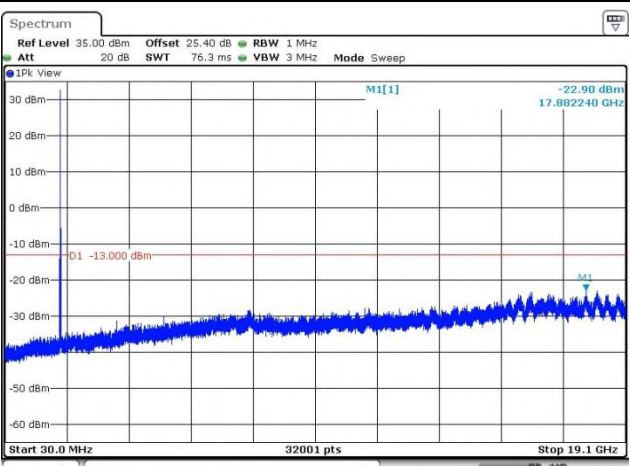
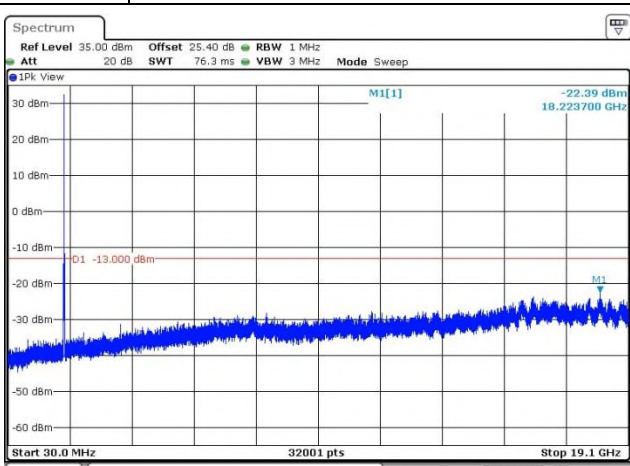
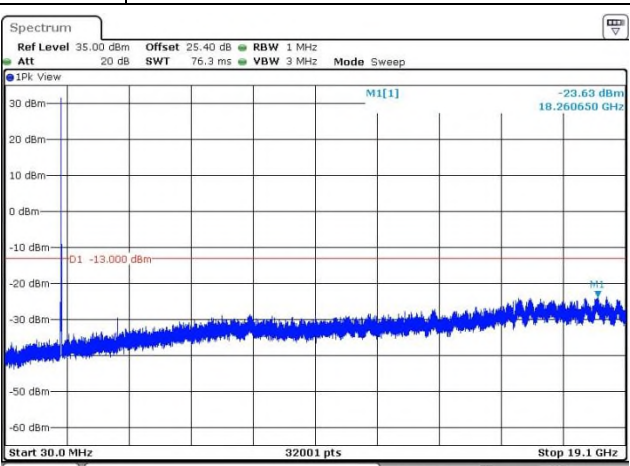
Mode	LTE Band 4, CB: 15MHz, QPSK	Mode	LTE Band 4, CB: 15MHz, 16QAM
Channel	2025	Channel	2025
			
Channel	20175	Channel	20175
			
Channel	20325	Channel	20325
			

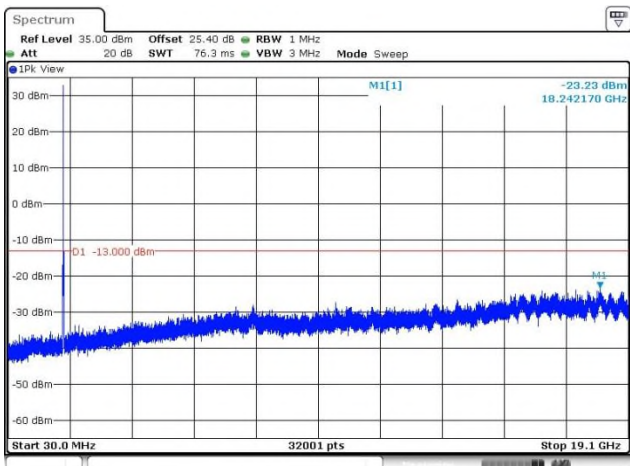
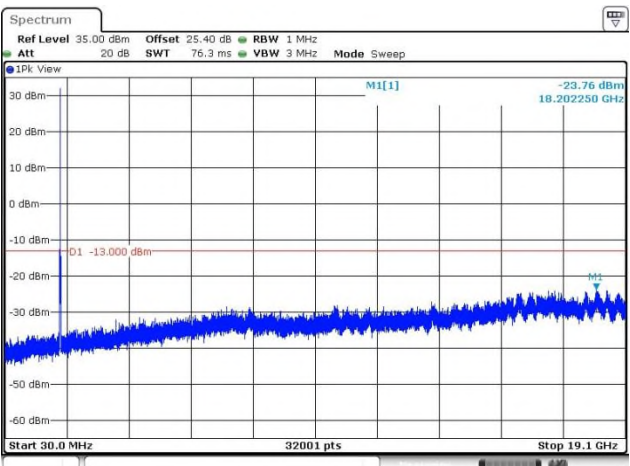
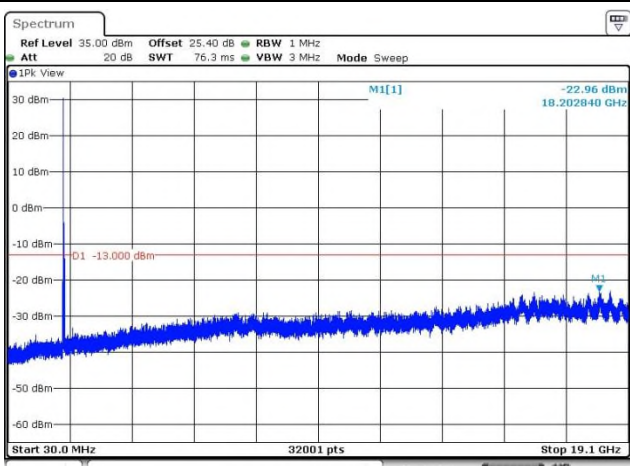
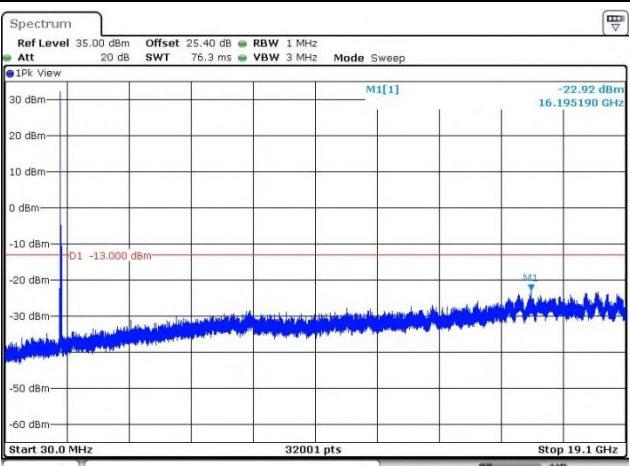
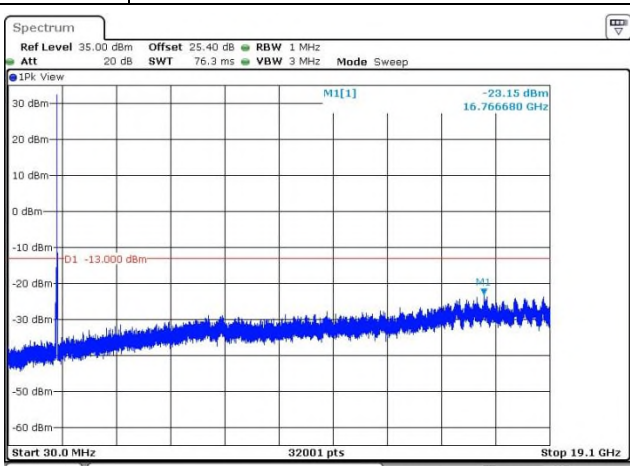
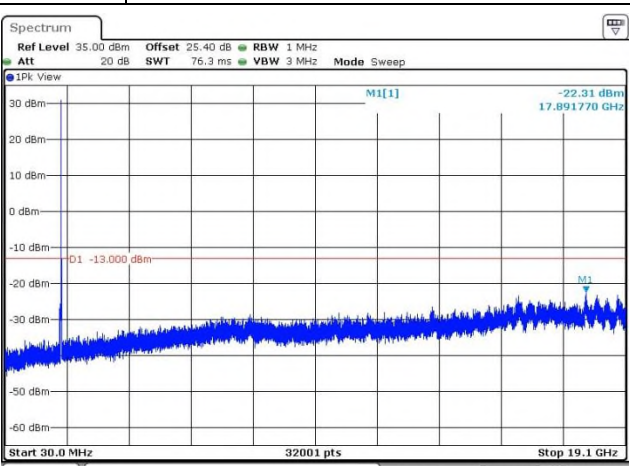
Mode	LTE Band 4, CB: 20MHz, QPSK	Mode	LTE Band 4, CB: 20MHz, 16QAM
Channel	20050	Channel	20050
			
Channel	20175	Channel	20175
			
Channel	20300	Channel	20300
			

3.4 Band Edge

3.4.1 Limit of Band Edge

The power of any emission outside of the authorized operating frequency ranges must be attenuated below the transmitting power (P) by a factor of at least $43 + 10 \log(P)$ dB equal to -13dBm.

3.4.2 Test Procedures

- 1 Lowest and highest operating channels are tested for this item.
- 2 Set RBW = 15 / 39 / 56 / 110 / 160 / 220 kHz, VBW = 62 / 120 / 180 / 330 / 510 / 680 kHz for channel bandwidth 1.4 / 3 / 5 / 10 / 15 / 20 MHz, detector = RMS, sweep time = auto to measure trace.
- 3 Set RBW = 20 / 50 / 100 / 200 / 200 / 300 kHz, VBW = 100 / 200 / 300 / 1000 / 1000 / 1000 kHz, for channel bandwidth 1.4 / 3 / 5 / 10 / 15 / 20 MHz, detector = RMS and use channel power measurement function of spectrum analyzer to integrate power over 1MHz.

3.4.3 Test Setup

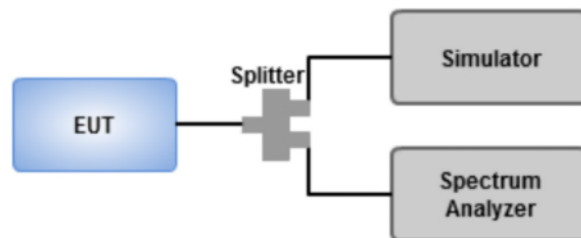

3.4.4 Test Result of Band Edge

















