

# FCC Test Report

**FCC ID** : N7NHL7588  
**Equipment** : Wireless Module  
**Model No.** : HL7588  
**Brand Name** : AirPrime  
**Applicant** : Sierra Wireless Inc.  
**Address** : 13811 Wireless Way Richmond, BC, V6V 3A4  
Canada  
**Standard** : 47 CFR FCC Part 27  
**Received Date** : Jul. 16, 2015  
**Tested Date** : Jul. 20 ~ Jul. 30, 2015

We, International Certification Corp., would like to declare that the tested sample has been evaluated and in compliance with the requirement of the above standards. The test results contained in this report refer exclusively to the product. It may be duplicated completely for legal use with the approval of the applicant. It shall not be reproduced except in full without the written approval of our laboratory.

Approved & Reviewed by:

  
\_\_\_\_\_  
Gary Chang / Manager



---

## Table of Contents

<b>1</b>	<b>GENERAL DESCRIPTION .....</b>	<b>5</b>
1.1	Information.....	5
1.2	Local Support Equipment List .....	7
1.3	Test Setup Chart .....	7
1.4	The Equipment List .....	8
1.5	Test Standards .....	9
1.6	Measurement Uncertainty .....	9
<b>2</b>	<b>TEST CONFIGURATION.....</b>	<b>10</b>
2.1	Testing Condition and Location Information.....	10
2.2	The Worst Test Modes and Channel Details .....	11
<b>3</b>	<b>TEST RESULTS.....</b>	<b>12</b>
3.1	Effective Radiated Power .....	12
3.2	Radiated Emissions.....	17
3.3	Conducted Emissions.....	26
3.4	Band Edge.....	31
3.5	Occupied Bandwidth and 26dB Bandwidth .....	52
3.6	Peak to Average Ratio .....	57
3.7	Frequency Stability .....	62
<b>4</b>	<b>TEST LABORATORY INFORMATION .....</b>	<b>65</b>

## Release Record

Report No.	Version	Description	Issued Date
FG571601P27	Rev. 01	Initial issue	Aug. 17, 2015
FG571601P27	Rev. 02	Add temperature and humidity chamber in equipment list	Aug. 24, 2015

## Summary of Test Results

FCC Rules	Test Items	Measured	Result
2.1046 27.50(b)(10) 27.50(c)(10)	Effective Radiated Power	Power[dBm]: LTE Band 13: 23.42 LTE Band 17: 23.36	Pass
2.1053 27.53(c) 27.53(g)	Radiated Emissions	Meet the requirement of limit	Pass
2.1053 / 27.53(f)	Radiated Spurious Emission in the 1559-1610MHz band	Meet the requirement of limit	Pass
2.1051 27.53(c) 27.53(g)	Conducted Emissions	Meet the requirement of limit	Pass
2.1051 27.53(c) 27.53(g)	Band Edge	Meet the requirement of limit	Pass
2.1049	Occupied Bandwidth	Meet the requirement of limit	Pass
2.1055 / 27.54	Frequency Stability	Meet the requirement of limit	Pass
27.50(d)(5)	Peak to Average Ratio	Meet the requirement of limit	Pass

# 1 General Description

## 1.1 Information

### 1.1.1 Specification of the Equipment under Test (EUT)

<b>Operating Frequency (MHz)</b>	LTE Band 13 Channel Bandwidth: 5MHz: 779.5 ~ 784.5 Channel Bandwidth: 10MHz: 782 LTE Band 17 Channel Bandwidth: 5MHz: 706.5 ~ 713.5 Channel Bandwidth: 10MHz: 709 ~ 711
<b>Modulation Type</b>	QPSK, 16QAM (Uplink)
<b>Release Version</b>	8
<b>Duplex Mode</b>	FDD
<b>UE category</b>	4
<b>H/W Version</b>	1.0
<b>S/W Version</b>	HL75xx.V.3.1

### 1.1.2 Maximum ERP and Emission Designator

Mode	Modulation	Maximum ERP (W)	Emission Designator
LTE Band 13, CB: 5MHz	QPSK	0.212	4M51G7D
LTE Band 13, CB: 5MHz	16QAM	0.196	4M50W7D
LTE Band 13, CB: 10MHz	QPSK	0.220	9M01G7D
LTE Band 13, CB: 10MHz	16QAM	0.200	8M97W7D
LTE Band 17, CB: 5MHz	QPSK	0.217	4M50G7D
LTE Band 17, CB: 5MHz	16QAM	0.200	4M50W7D
LTE Band 17, CB: 10MHz	QPSK	0.216	8M97G7D
LTE Band 17, CB: 10MHz	16QAM	0.201	8M94W7D

### 1.1.3 Antenna Details

Ant. No.	Type	Gain (dBi)	Connector	Remark
1	Dipole	2	R-SMA	---

Note: The antenna is for testing use only.

### 1.1.4 EUT Operational Condition

<b>Supply Voltage</b>	3.7 Vdc from host		
<b>Operational Voltage</b>	<input checked="" type="checkbox"/> Vnom (3.7 V)	<input checked="" type="checkbox"/> Vmax (4.5 V)	<input checked="" type="checkbox"/> Vmin (3.2 V)
<b>Operational Climatic</b>	<input checked="" type="checkbox"/> Tnom (20°C)	<input checked="" type="checkbox"/> Tmax (55°C)	<input checked="" type="checkbox"/> Tmin (-20°C)

### 1.1.5 Operating Channel List

LTE Band 13		
Channel Bandwidth (MHz)	Channel	Frequency (MHz)
5	23205	779.5
5	23230	782.0
5	23255	784.5
10	23230	782.0

LTE Band 17		
Channel Bandwidth (MHz)	Channel	Frequency (MHz)
5	23755	706.5
5	23790	710.0
5	23825	713.5
10	23780	709.0
10	23790	710.0
10	23800	711.0

## 1.2 Local Support Equipment List

Support Equipment List						
No.	Equipment	Brand	Model	S/N	FCC ID	Signal cable / Length (m)
1	Power Supply	GWINSTEK	GPC-60300	EM884797	---	---

## 1.3 Test Setup Chart

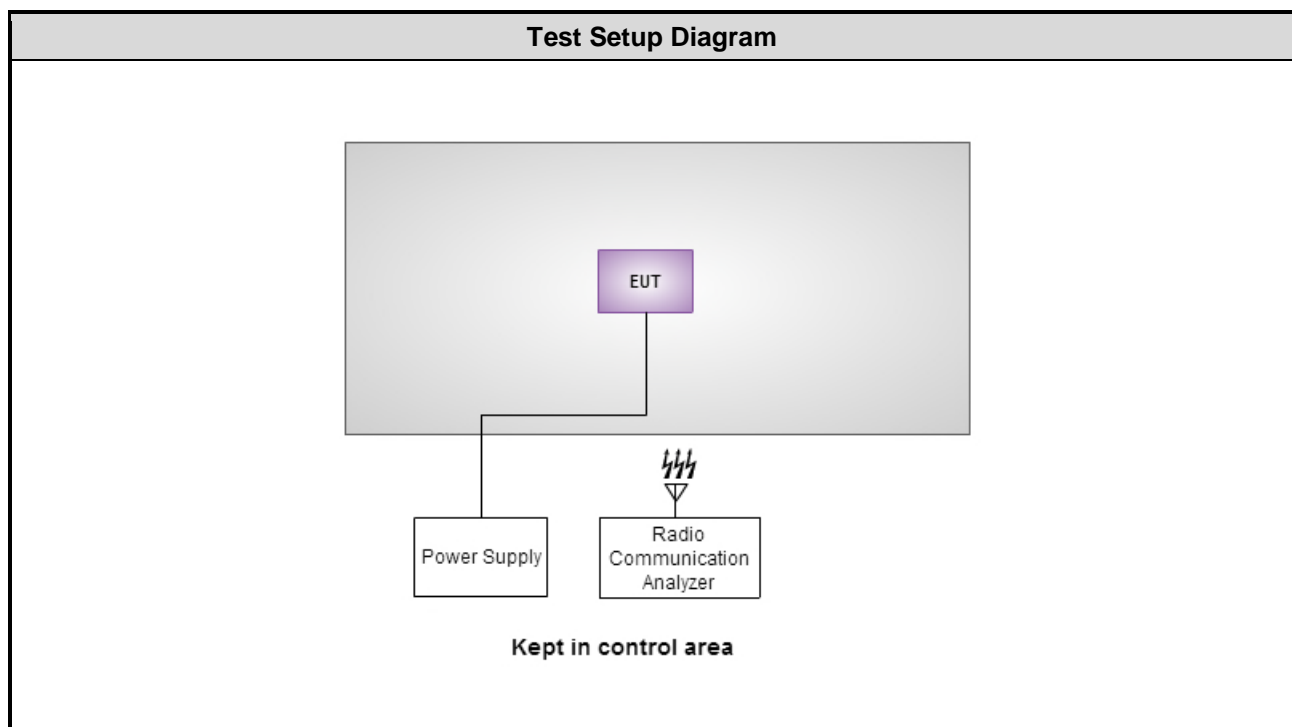

## 1.4 The Equipment List

Test Item	RF Conducted				
Test Site	(TH01-WS)				
Instrument	Manufacturer	Model No.	Serial No.	Calibration Date	Calibration Until
Spectrum Analyzer	R&S	FSV40	101063	Feb. 03, 2015	Feb. 02, 2016
TEMP&HUMIDITY CHAMBER	GIANT FORCE	GCT-225-40-SP-SD	MAF1212-002	Dec. 03, 2014	Dec. 02, 2015
Power Meter	Anritsu	ML2495A	1241002	Sep. 29, 2014	Sep. 28, 2015
Power Sensor	Anritsu	MA2411B	1207366	Sep. 29, 2014	Sep. 28, 2015
Radio Communication Analyzer	Anritsu	MT8820C	6201240341	Mar. 19, 2015	Mar. 17, 2016
Measurement Software	Sporton	Sporton_1	1.3.30	NA	NA

Note: Calibration Interval of instruments listed above is one year.

Test Item	Radiated Emission				
Test Site	966 chamber 2 / (03CH02-WS)				
Instrument	Manufacturer	Model No.	Serial No.	Calibration Date	Calibration Until
Spectrum Analyzer	R&S	FSV40	101499	Dec. 31, 2014	Dec. 30, 2015
Receiver	R&S	ESR3	101657	Jan. 15, 2015	Jan. 14, 2016
Bilog Antenna	SCHWARZBECK	VULB9168	VULB9168-524	Oct. 16, 2014	Oct. 15, 2015
Horn Antenna 1G-18G	SCHWARZBECK	BBHA 9120 D	BBHA 9120 D 1095	Oct. 14, 2014	Oct. 13, 2015
Horn Antenna 18G-40G	SCHWARZBECK	BBHA 9170	BBHA 9170517	Nov. 10, 2014	Nov. 09, 2015
Loop Antenna	R&S	HFH2-Z2	11900	Nov. 10, 2014	Nov. 09, 2015
Preamplifier	Burgeon	BPA-530	100218	Nov. 10, 2014	Nov. 09, 2015
Preamplifier	Agilent	83017A	MY39501309	Sep. 29, 2014	Sep. 28, 2015
Preamplifier	EMC	EMC184045B	980192	Aug. 26, 2014	Aug. 25, 2015
RF Cable	HUBER+SUHNER	SUCOFLEX104	MY16140/4	Dec. 16, 2014	Dec. 15, 2015
RF Cable	HUBER+SUHNER	SUCOFLEX104	MY16018/4	Dec. 16, 2014	Dec. 15, 2015
RF Cable	HUBER+SUHNER	SUCOFLEX104	MY16015/4	Dec. 16, 2014	Dec. 15, 2015
LF cable 3M	Woken	CFD400NL-LW	CFD400NL-003	Dec. 16, 2014	Dec. 15, 2015
LF cable 10M	Woken	CFD400NL-LW	CFD400NL-004	Dec. 16, 2014	Dec. 15, 2015
Measurement Software	AUDIX	e3	6.120210g	NA	NA

Note: Calibration Interval of instruments listed above is one year.



## 1.5 Test Standards

According to the specification of EUT, the EUT must comply with following standards.

47 CFR FCC Part 27

47 CFR FCC Part 2

ANSI C63.4-2003

ANSI / TIA / EIA-603-D -2010

FCC KDB 971168 D01 Power Meas License Digital Systems v02r02

FCC KDB 971168 D02 Misc OOBE License Digital Systems v01

FCC KDB 412172 D01 Determining ERP and EIRP v01r01

## 1.6 Measurement Uncertainty

ISO/IEC 17025 requires that an estimate of the measurement uncertainties associated with the emissions test results be included in the report. The measurement uncertainties given below are based on a 95% confidence level (based on a coverage factor (k=2))

Measurement Uncertainty	
Parameters	Uncertainty
Bandwidth	±34.134 Hz
Conducted power	±0.808 dB
Frequency error	±34.134 Hz
Temperature	±0.6 °C
Conducted emission	±2.670 dB
AC conducted emission	±2.92 dB
Radiated emission ≤ 1GHz	±3.62 dB
Radiated emission > 1GHz	±5.60 dB

---

## 2 Test Configuration

### 2.1 Testing Condition and Location Information

Test Item	Test Site	Ambient Condition	Tested By
RF conducted	TH01-WS	23°C / 64%	Felix Sung
Radiated Emissions	03CH02-WS	22°C / 64%	Anderson Hung

 FCC site registration No.: 657002

 IC site registration No.: 10807A-2

## 2.2 The Worst Test Modes and Channel Details

### LTE Band 13

Test item	Channel Bandwidth	Modulation	Test channel
E.R.P Conducted Emissions Occupied Bandwidth Peak to Average Ratio	5 MHz 10 MHz	QPSK / 16QAM QPSK / 16QAM	23205, 23230, 23255 23230
Radiated Emission $\leq$ 1GHz	5 MHz 10 MHz	QPSK QPSK	23205 23230
Radiated Emission $>$ 1GHz	5 MHz 10 MHz	QPSK QPSK	23205, 23230, 23255 23230
Band Edge	5 MHz 10 MHz	QPSK / 16QAM QPSK / 16QAM	23205, 23255 23230
Frequency Stability	5 MHz 10 MHz	QPSK QPSK	23230 23230
<b>Note:</b>			
1. The EUT was pretested with 3 orientations placed on the table for the radiated emission measurement – X, Y, and Z-plane. The <b>Y-plane</b> results were found as the worst case and were shown in this report.			

### LTE Band 17

Test item	Channel Bandwidth	Modulation	Test channel
E.R.P Conducted Emissions Occupied Bandwidth Peak to Average Ratio	5 MHz 10 MHz	QPSK / 16QAM QPSK / 16QAM	23755, 23790, 23825 23780, 23790, 23800
Radiated Emission $\leq$ 1GHz	5 MHz 10 MHz	QPSK QPSK	23755 23780
Radiated Emission $>$ 1GHz	5 MHz 10 MHz	QPSK QPSK	23755, 23790, 23825 23780, 23790, 23800
Band Edge	5 MHz 10 MHz	QPSK / 16QAM QPSK / 16QAM	23755, 23825 23780, 23800
Frequency Stability	5 MHz 10 MHz	QPSK QPSK	23790 23790
<b>Note:</b>			
2. The EUT was pretested with 3 orientations placed on the table for the radiated emission measurement – X, Y, and Z-plane. The <b>Y-plane</b> results were found as the worst case and were shown in this report.			

## 3 Test Results

### 3.1 Effective Radiated Power

#### 3.1.1 Limit of Effective Radiated Power

Portable stations (hand-held devices) are limited to 3 watts ERP.

#### 3.1.2 Test Procedures

For Conducted power measurement:

1. The EUT links up with simulator and is set to maximum output power level at low / middle / high channel.
2. Measure the output power of low / middle / high channel of the EUT.

For ERP measurement:

EPR can be calculated by below formula from KDB 412172 D01.

1.  $EIRP = P_T + G_T - L_C$   
 $P_T$  = transmitter output power, in dBm.  
 $G_T$  = gain of the transmitting antenna, in dBi (EIRP).  
 $L_C$  = signal attenuation in the connecting cable between the transmitter and antenna, in dB.
2.  $ERP = EIRP - 2.15 \text{ dB}$ .

#### 3.1.3 Test Setup

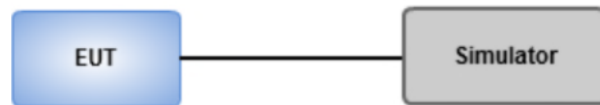

### 3.1.4 Test Result of Conducted power (dBm)

Band / Channel Bandwidth			LTE Band 13 / CB: 5MHz		
Channel			23205	23230	23255
Frequency (MHz)			779.5	782.0	784.5
Mode	RB	RB Offset	Maximum AV Power (dBm)		
QPSK	1	0	23.21	23.35	23.28
	1	12	23.32	23.40	23.24
	1	24	<b>23.42</b>	23.29	23.30
	12	0	22.70	22.61	22.57
	12	6	22.56	22.62	22.52
	12	11	22.57	22.62	22.61
	25	0	22.51	22.62	22.58
16QAM	1	0	22.55	22.83	22.85
	1	12	23.07	22.67	22.72
	1	24	22.98	22.69	22.74
	12	0	21.75	21.86	21.73
	12	6	21.77	21.64	21.69
	12	11	21.80	21.83	21.74
	25	0	21.72	21.69	21.80

Band / Channel Bandwidth			LTE Band 13 / CB: 10MHz		
Channel			23230		
Frequency (MHz)			782.0		
Mode	RB	RB Offset	Maximum AV Power (dBm)		
QPSK	1	0	23.23		
	1	24	23.36		
	1	49	<b>23.57</b>		
	25	0	22.64		
	25	12	22.68		
	25	24	22.63		
	50	0	22.63		
16QAM	1	0	22.48		
	1	24	23.17		
	1	49	22.56		
	25	0	21.57		
	25	12	21.58		
	25	24	21.76		
	50	0	21.66		

Band / Channel Bandwidth			LTE Band 17 / CB: 5MHz		
Channel			23755	23790	23825
Frequency (MHz)			706.5	710.0	713.5
Mode	RB	RB Offset	Maximum AV Power (dBm)		
QPSK	1	0	23.35	23.23	23.47
	1	12	23.34	23.30	23.44
	1	24	<b>23.51</b>	23.20	23.30
	12	0	22.57	22.66	22.52
	12	6	22.59	22.58	22.55
	12	11	22.45	22.56	22.55
	25	0	22.50	22.65	22.61
16QAM	1	0	22.85	22.78	22.66
	1	12	22.61	23.17	22.83
	1	24	22.75	22.64	23.09
	12	0	21.93	21.78	21.82
	12	6	21.90	21.78	21.81
	12	11	21.86	21.68	21.86
	25	0	21.76	21.70	21.78

Band / Channel Bandwidth			LTE Band 17 / CB: 10MHz		
Channel			23780	23790	23800
Frequency (MHz)			709.0	710.0	711.0
Mode	RB	RB Offset	Maximum AV Power (dBm)		
QPSK	1	0	23.33	23.28	23.27
	1	24	23.42	23.38	23.27
	1	49	<b>23.49</b>	23.26	23.15
	25	0	23.40	22.61	22.46
	25	12	23.30	22.41	22.55
	25	24	23.35	22.58	22.48
	50	0	22.54	22.61	22.51
16QAM	1	0	23.18	22.96	21.71
	1	24	22.81	22.88	22.71
	1	49	23.08	23.06	22.30
	25	0	21.67	21.69	21.76
	25	12	21.64	21.65	21.71
	25	24	21.63	21.64	21.66
	50	0	21.78	21.73	21.74

### 3.1.5 Test Result of Effective Radiated Power (dBm)

Mode							
LTE Band 13, CB: 5MHz, QPSK							
Channel	Frequency (MHz)	Max. Conducted Output Power (dBm)	Max. Antenna Gain(dBi)	EIRP (dBm)	ERP (dBm)	ERP (W)	Limit (W)
23205	779.5	23.42	2	25.42	<b>23.27</b>	0.212	3
23230	782.0	23.40	2	25.40	23.25	0.211	3
23255	784.5	23.30	2	25.30	23.15	0.207	3

Mode							
LTE Band 13, CB: 5MHz, 16QAM							
Channel	Frequency (MHz)	Max. Conducted Output Power (dBm)	Max. Antenna Gain(dBi)	EIRP (dBm)	ERP (dBm)	ERP (W)	Limit (W)
23205	779.5	23.07	2	25.07	22.92	0.196	3
23230	782.0	22.83	2	24.83	22.68	0.185	3
23255	784.5	22.85	2	24.85	22.70	0.186	3

Mode							
LTE Band 13, CB: 10MHz, QPSK							
Channel	Frequency (MHz)	Max. Conducted Output Power (dBm)	Max. Antenna Gain(dBi)	EIRP (dBm)	ERP (dBm)	ERP (W)	Limit (W)
23230	782.0	23.57	2	25.57	<b>23.42</b>	0.220	3

Mode							
LTE Band 13, CB: 10MHz, 16QAM							
Channel	Frequency (MHz)	Max. Conducted Output Power (dBm)	Max. Antenna Gain(dBi)	EIRP (dBm)	ERP (dBm)	ERP (W)	Limit (W)
23230	782.0	23.17	2	25.17	23.02	0.200	3

Mode	LTE Band 17, CB: 5MHz, QPSK						
Channel	Frequency (MHz)	Max. Conducted Output Power (dBm)	Max. Antenna Gain(dBi)	EIRP (dBm)	ERP (dBm)	ERP (W)	Limit (W)
23755	706.5	23.51	2	25.51	<b>23.36</b>	0.217	3
23790	710.0	23.30	2	25.30	23.15	0.207	3
23825	713.5	23.47	2	25.47	23.32	0.215	3

Mode	LTE Band 17, CB: 5MHz, 16QAM						
Channel	Frequency (MHz)	Max. Conducted Output Power (dBm)	Max. Antenna Gain(dBi)	EIRP (dBm)	ERP (dBm)	ERP (W)	Limit (W)
23755	706.5	22.85	2	24.85	22.70	0.186	3
23790	710.0	23.17	2	25.17	23.02	0.200	3
23825	713.5	23.09	2	25.09	22.94	0.197	3

Mode	LTE Band 17, CB: 10MHz, QPSK						
Channel	Frequency (MHz)	Max. Conducted Output Power (dBm)	Max. Antenna Gain(dBi)	EIRP (dBm)	ERP (dBm)	ERP (W)	Limit (W)
23780	709.0	23.49	2	25.49	<b>23.34</b>	0.216	3
23790	710.0	23.38	2	25.38	23.23	0.210	3
23800	711.0	23.27	2	25.27	23.12	0.205	3

Mode	LTE Band 17, CB: 10MHz, 16QAM						
Channel	Frequency (MHz)	Max. Conducted Output Power (dBm)	Max. Antenna Gain(dBi)	EIRP (dBm)	ERP (dBm)	ERP (W)	Limit (W)
23780	709.0	23.18	2	25.18	23.03	0.201	3
23790	710.0	23.06	2	25.06	22.91	0.195	3
23800	711.0	22.71	2	24.71	22.56	0.180	3



## 3.2 Radiated Emissions

### 3.2.1 Limit of Radiated Emissions

The power of any emission outside of the authorized operating frequency ranges must be attenuated below the transmitting power (P) by a factor of at least  $43 + 10 \log(P)$  dB equal to -13dBm.

For operations in the 746-758 MHz, 775-788 MHz, and 805-806 MHz bands, emissions in the band 1559-1610 MHz shall be limited to -70 dBW/MHz equivalent isotropically radiated power (EIRP) for wideband signals, and -80 dBW EIRP for discrete emissions of less than 700 Hz bandwidth.

### 3.2.2 Test Procedures

1. Measurement is made at a semi-anechoic chamber that incorporates a turntable allowing a EUT rotation of 360°. A continuously-rotating, remotely-controlled turntable is installed at the test site to support the EUT and facilitate determination of the direction of maximum radiation for each EUT emission frequency. The EUT is placed at a height of 0.8 m test table above the ground plane.
2. Measurement is made with the antenna positioned in both the horizontal and vertical planes of polarization. The measurement antenna is varied in height (1m ~ 4m) above the reference ground plane to obtain the maximum signal strength. Distance between EUT and antenna is 3 m.
3. This investigation is performed with the EUT rotated 360°, the antenna height scanned between 1 m and 4 m, and the antenna rotated to repeat the measurements for both the horizontal and vertical antenna polarizations.
4. After finding the max radiated emission, substitution method will be used for getting effective radiated power. EUT will be removed and substitution antenna will be placed at same position. Signal generator will output CW signal to substitution antenna through a RF cable. Rotate turntable and move antenna to find maximum radiated emission. Adjust output power of signal generator to let the maximum radiated emission is same as step 3. Record the output power level.
5. E.I.R.P = output power of step 4 + gain of substitution antenna – cable loss of RF cable. ERP can be calculated by below formula:  
$$E.R.P = E.I.R.P - 2.15dB.$$

### 3.2.3 Test Setup

#### Radiated Emissions below 1 GHz

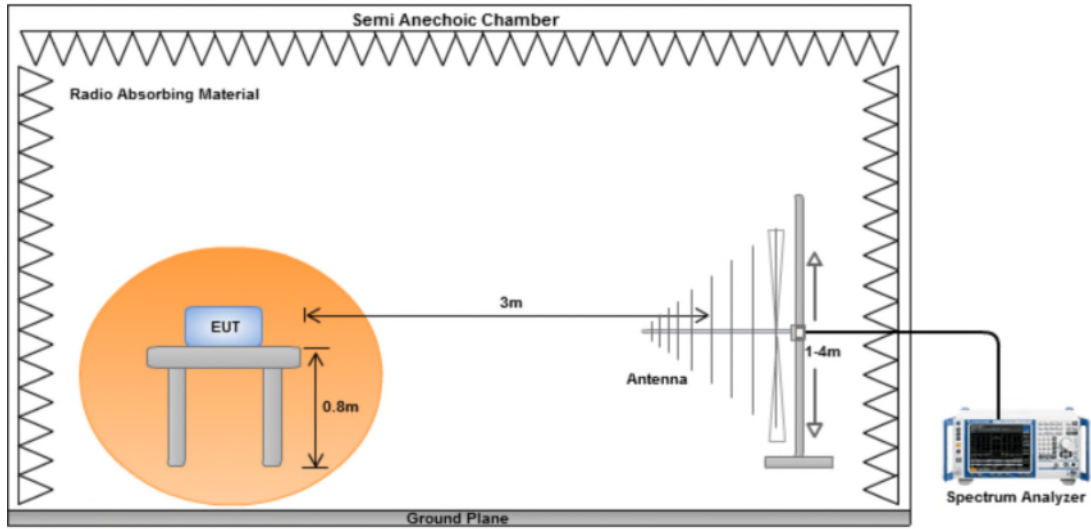

#### Radiated Emissions above 1 GHz

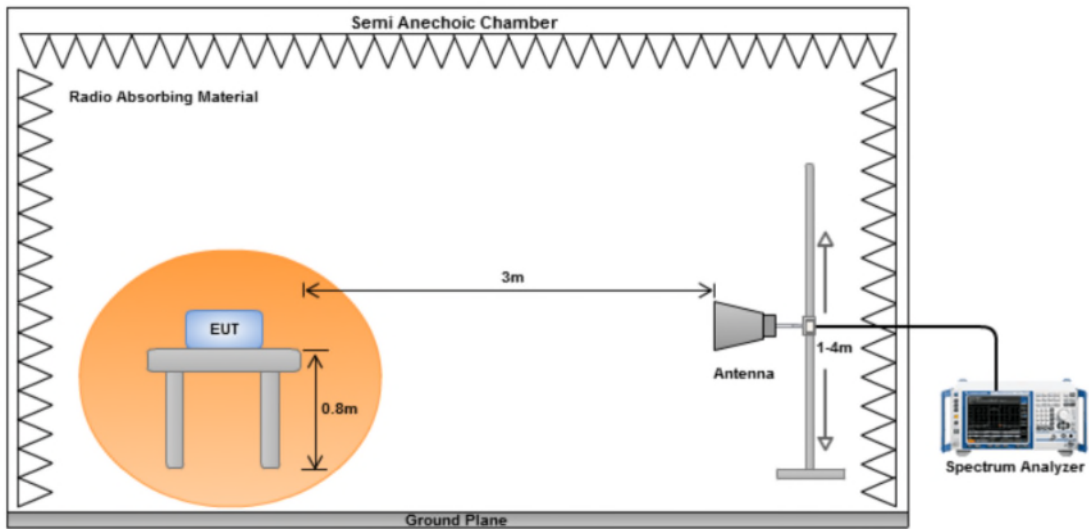

### 3.2.4 Test Result of Radiated Emissions below 1GHz

Mode							
LTE Band 13, CB: 5MHz, 1RB, Offset 24, Channel : 23205							
Frequency (MHz)	Antenna Polarity	E.R.P (dBm)	Limit (dBm)	Margin (dB)	S.A Reading (dBm)	S.G Power Vaule (dBm)	Correction Factor (dB)
42.61	H	-62.77	-13.00	-49.77	-62.81	-48.70	-11.92
98.87	H	-62.61	-13.00	-49.61	-53.62	-60.75	0.29
136.70	H	-60.38	-13.00	-47.38	-52.67	-56.99	-1.24
171.62	H	-61.17	-13.00	-48.17	-52.59	-59.89	0.87
223.03	H	-70.34	-13.00	-57.34	-59.42	-72.57	4.38
738.10	H	-62.54	-13.00	-49.54	-63.40	-63.87	3.48
39.70	V	-54.51	-13.00	-41.51	-44.85	-40.02	-12.34
97.90	V	-57.12	-13.00	-44.12	-47.97	-55.28	0.31
147.37	V	-57.41	-13.00	-44.41	-51.96	-54.09	-1.17
155.13	V	-58.76	-13.00	-45.76	-53.65	-55.63	-0.98
268.62	V	-59.30	-13.00	-46.30	-53.93	-61.46	4.31
579.99	V	-63.68	-13.00	-50.68	-64.62	-65.46	3.93

Mode							
LTE Band 13, CB: 10MHz, 1RB, Offset 49, Channel : 23230							
Frequency (MHz)	Antenna Polarity	E.R.P (dBm)	Limit (dBm)	Margin (dB)	S.A Reading (dBm)	S.G Power Vaule (dBm)	Correction Factor (dB)
38.73	H	-63.24	-13.00	-50.24	-63.92	-48.61	-12.48
98.87	H	-62.52	-13.00	-49.52	-53.53	-60.66	0.29
165.80	H	-62.07	-13.00	-49.07	-53.80	-59.92	0.00
178.41	H	-61.99	-13.00	-48.99	-53.04	-61.72	1.88
255.04	H	-73.90	-13.00	-60.90	-64.18	-76.10	4.35
747.80	H	-61.55	-13.00	-48.55	-62.66	-62.81	3.41
44.55	V	-55.34	-13.00	-42.34	-46.08	-41.55	-11.64
93.05	V	-55.32	-13.00	-42.32	-45.96	-53.58	0.41
157.07	V	-57.10	-13.00	-44.10	-52.07	-54.02	-0.93
214.30	V	-60.39	-13.00	-47.39	-54.70	-62.62	4.38
269.59	V	-61.95	-13.00	-48.95	-56.56	-64.10	4.30
589.69	V	-62.34	-13.00	-49.34	-63.42	-64.05	3.86

NOTE: ERP = S.G power value + correction factor - 2.15.

Mode							
LTE Band 17, CB: 5MHz, 1RB, Offset 24, Channel : 23755							
Frequency (MHz)	Antenna Polarity	E.R.P (dBm)	Limit (dBm)	Margin (dB)	S.A Reading (dBm)	S.G Power Vaule (dBm)	Correction Factor (dB)
36.79	H	-62.71	-13.00	-49.71	-63.31	-47.81	-12.75
44.55	H	-61.00	-13.00	-48.00	-60.52	-47.21	-11.64
107.60	H	-63.96	-13.00	-50.96	-54.74	-61.71	-0.10
139.61	H	-65.22	-13.00	-52.22	-57.84	-61.73	-1.34
179.38	H	-61.98	-13.00	-48.98	-52.98	-61.86	2.03
192.96	H	-68.40	-13.00	-55.40	-57.57	-69.84	3.59
44.55	V	-54.81	-13.00	-41.81	-45.55	-41.02	-11.64
98.87	V	-57.86	-13.00	-44.86	-48.76	-56.00	0.29
151.25	V	-60.02	-13.00	-47.02	-54.74	-56.80	-1.07
171.62	V	-61.14	-13.00	-48.14	-55.76	-59.86	0.87
208.48	V	-63.47	-13.00	-50.47	-57.68	-65.71	4.39
731.31	V	-56.23	-13.00	-43.23	-58.31	-57.62	3.54

Mode							
LTE Band 17, CB: 10MHz, 1RB, Offset 49, Channel : 23780							
Frequency (MHz)	Antenna Polarity	E.R.P (dBm)	Limit (dBm)	Margin (dB)	S.A Reading (dBm)	S.G Power Vaule (dBm)	Correction Factor (dB)
44.55	H	-60.22	-13.00	-47.22	-59.74	-46.43	-11.64
61.04	H	-71.04	-13.00	-58.04	-64.28	-60.48	-8.41
106.63	H	-64.29	-13.00	-51.29	-55.09	-62.09	-0.05
144.46	H	-71.06	-13.00	-58.06	-63.57	-67.67	-1.24
173.56	H	-54.47	-13.00	-41.47	-45.79	-53.48	1.16
265.71	H	-67.79	-13.00	-54.79	-58.38	-69.96	4.32
38.73	V	-53.03	-13.00	-40.03	-43.26	-38.40	-12.48
98.87	V	-57.86	-13.00	-44.86	-48.76	-56.00	0.29
138.64	V	-61.36	-13.00	-48.36	-55.57	-57.90	-1.31
171.62	V	-59.42	-13.00	-46.42	-54.04	-58.14	0.87
250.19	V	-65.43	-13.00	-52.43	-60.32	-67.65	4.37
632.37	V	-65.12	-13.00	-52.12	-66.24	-66.84	3.87

NOTE: ERP = S.G power value + correction factor - 2.15.

### 3.2.5 Test Result of Radiated Emissions above 1GHz

Mode							
LTE Band 13, CB: 5MHz, 1RB, Offset 24, Channel : 23205							
Frequency (MHz)	Antenna Polarity	E.R.P (dBm)	Limit (dBm)	Margin (dB)	S.A Reading (dBm)	S.G Power Vaule (dBm)	Correction Factor (dB)
2345.20	H	-57.71	-13.00	-44.71	-63.53	-61.68	6.12
3126.60	H	-36.99	-13.00	-23.99	-47.22	-40.99	6.15
3908.20	H	-51.55	-13.00	-38.55	-64.27	-55.89	6.49
2345.20	V	-57.06	-13.00	-44.06	-64.22	-61.03	6.12
3126.60	V	-34.14	-13.00	-21.14	-43.34	-38.14	6.15
3908.20	V	-51.35	-13.00	-38.35	-63.65	-55.69	6.49

Mode							
LTE Band 13, CB: 5MHz, 1RB, Offset 24, Channel : 23230							
Frequency (MHz)	Antenna Polarity	E.R.P (dBm)	Limit (dBm)	Margin (dB)	S.A Reading (dBm)	S.G Power Vaule (dBm)	Correction Factor (dB)
2352.40	H	-57.71	-13.00	-44.71	-63.51	-61.67	6.11
3136.50	H	-33.67	-13.00	-20.67	-43.98	-37.68	6.16
3917.60	H	-52.92	-13.00	-39.92	-65.52	-57.25	6.48
2352.40	V	-56.43	-13.00	-43.43	-63.54	-60.39	6.11
3136.50	V	-36.89	-13.00	-23.89	-46.12	-40.90	6.16
3917.60	V	-52.26	-13.00	-39.26	-64.55	-56.59	6.48

Mode							
LTE Band 13, CB: 5MHz, 1RB, Offset 24, Channel : 23255							
Frequency (MHz)	Antenna Polarity	E.R.P (dBm)	Limit (dBm)	Margin (dB)	S.A Reading (dBm)	S.G Power Vaule (dBm)	Correction Factor (dB)
2360.00	H	-58.33	-13.00	-45.33	-64.11	-62.29	6.11
3146.60	H	-33.01	-13.00	-20.01	-43.39	-37.04	6.18
3933.20	H	-51.43	-13.00	-38.43	-64.11	-55.75	6.47
2360.00	V	-56.24	-13.00	-43.24	-63.31	-60.20	6.11
3146.60	V	-38.72	-13.00	-25.72	-47.97	-42.75	6.18
3933.20	V	-52.59	-13.00	-39.59	-64.88	-56.91	6.47

NOTE: ERP = S.G power value + correction factor - 2.15.

Mode	LTE Band 13, CB: 10MHz, 1RB, Offset 49, Channel : 23230						
Frequency (MHz)	Antenna Polarity	E.R.P (dBm)	Limit (dBm)	Margin (dB)	S.A Reading (dBm)	S.G Power Vaule (dBm)	Correction Factor (dB)
2359.60	H	-57.24	-13.00	-44.24	-63.02	-61.20	6.11
3145.40	H	-33.33	-13.00	-20.33	-43.70	-37.36	6.18
3931.20	H	-52.43	-13.00	-39.43	-65.12	-56.75	6.47
2359.60	V	-56.08	-13.00	-43.08	-63.15	-60.04	6.11
3145.40	V	-36.39	-13.00	-23.39	-45.64	-40.42	6.18
3931.20	V	-52.42	-13.00	-39.42	-64.71	-56.74	6.47

NOTE: ERP = S.G power value + correction factor - 2.15.

Mode							
LTE Band 17, CB: 5MHz, 1RB, Offset 24, Channel : 23755							
Frequency (MHz)	Antenna Polarity	E.R.P (dBm)	Limit (dBm)	Margin (dB)	S.A Reading (dBm)	S.G Power Vaule (dBm)	Correction Factor (dB)
1417.30	H	-36.82	-13.00	-23.82	-38.58	-38.94	4.27
2126.00	H	-53.79	-13.00	-40.79	-59.51	-57.77	6.13
2834.60	H	-46.11	-13.00	-33.11	-55.00	-49.96	6.00
1417.30	V	-43.11	-13.00	-30.11	-44.11	-45.23	4.27
2126.00	V	-56.94	-13.00	-43.94	-63.46	-60.92	6.13
2834.60	V	-48.17	-13.00	-35.17	-56.79	-52.02	6.00

Mode							
LTE Band 17, CB: 5MHz, 1RB, Offset 24, Channel : 23790							
Frequency (MHz)	Antenna Polarity	E.R.P (dBm)	Limit (dBm)	Margin (dB)	S.A Reading (dBm)	S.G Power Vaule (dBm)	Correction Factor (dB)
1424.30	H	-37.24	-13.00	-24.24	-38.99	-39.38	4.29
2136.50	H	-54.25	-13.00	-41.25	-60.05	-58.23	6.13
2848.60	H	-42.12	-13.00	-29.12	-51.05	-45.97	6.00
1424.30	V	-43.74	-13.00	-30.74	-44.74	-45.88	4.29
2136.50	V	-57.07	-13.00	-44.07	-63.81	-61.05	6.13
2848.60	V	-44.99	-13.00	-31.99	-53.63	-48.84	6.00

Mode							
LTE Band 17, CB: 5MHz, 1RB, Offset 24, Channel : 23825							
Frequency (MHz)	Antenna Polarity	E.R.P (dBm)	Limit (dBm)	Margin (dB)	S.A Reading (dBm)	S.G Power Vaule (dBm)	Correction Factor (dB)
1431.40	H	-44.04	-13.00	-31.04	-45.79	-46.21	4.32
2147.10	H	-57.81	-13.00	-44.81	-63.70	-61.79	6.13
2862.70	H	-44.18	-13.00	-31.18	-53.13	-48.02	5.99
1431.40	V	-40.46	-13.00	-27.46	-41.47	-42.63	4.32
2147.10	V	-50.63	-13.00	-37.63	-57.59	-54.61	6.13
2862.70	V	-44.64	-13.00	-31.64	-53.29	-48.48	5.99

NOTE: ERP = S.G power value + correction factor - 2.15.

Mode							
LTE Band 17, CB: 10MHz, 1RB, Offset 49, Channel : 23780							
Frequency (MHz)	Antenna Polarity	E.R.P (dBm)	Limit (dBm)	Margin (dB)	S.A Reading (dBm)	S.G Power Vaule (dBm)	Correction Factor (dB)
1427.60	H	-36.43	-13.00	-23.43	-38.19	-38.58	4.30
2139.70	H	-53.41	-13.00	-40.41	-59.23	-57.39	6.13
2853.10	H	-45.84	-13.00	-32.84	-54.78	-49.68	5.99
1427.60	V	-42.68	-13.00	-29.68	-43.69	-44.83	4.30
2139.70	V	-56.77	-13.00	-43.77	-63.57	-60.75	6.13
2853.10	V	-48.04	-13.00	-35.04	-56.69	-51.88	5.99

Mode							
LTE Band 17, CB: 10MHz, 1RB, Offset 49, Channel : 23790							
Frequency (MHz)	Antenna Polarity	E.R.P (dBm)	Limit (dBm)	Margin (dB)	S.A Reading (dBm)	S.G Power Vaule (dBm)	Correction Factor (dB)
1429.10	H	-36.89	-13.00	-23.89	-38.64	-39.05	4.31
2142.50	H	-53.83	-13.00	-40.83	-59.67	-57.81	6.13
2857.30	H	-41.74	-13.00	-28.74	-50.68	-45.58	5.99
1429.10	V	-43.42	-13.00	-30.42	-44.42	-45.58	4.31
2142.50	V	-56.80	-13.00	-43.80	-63.66	-60.78	6.13
2857.30	V	-44.51	-13.00	-31.51	-53.16	-48.35	5.99

Mode							
LTE Band 17, CB: 10MHz, 1RB, Offset 49, Channel : 23800							
Frequency (MHz)	Antenna Polarity	E.R.P (dBm)	Limit (dBm)	Margin (dB)	S.A Reading (dBm)	S.G Power Vaule (dBm)	Correction Factor (dB)
1430.50	H	-43.61	-13.00	-30.61	-45.36	-45.77	4.31
2146.90	H	-57.44	-13.00	-44.44	-63.33	-61.42	6.13
2861.80	H	-43.98	-13.00	-30.98	-52.93	-47.82	5.99
1430.50	V	-40.30	-13.00	-27.30	-41.31	-42.46	4.31
2146.90	V	-50.51	-13.00	-37.51	-57.46	-54.49	6.13
2861.80	V	-44.34	-13.00	-31.34	-52.99	-48.18	5.99

NOTE: ERP = S.G power value + correction factor - 2.15.



### 3.2.6 Test Result of Radiated Emissions in the 1559-1610MHz band

Mode							
LTE Band 13, CB: 5MHz, 1RB, Offset 24, Channel : 23205							
Frequency (MHz)	Antenna Polarity	E.I.R.P. (dBm)	Limit (dBm)	Margin (dB)	S.A Reading (dBm)	S.G Power Vaule (dBm)	Correction Factor (dB)
1563.30	H	-54.40	-40.00	-14.40	-57.47	-59.16	4.76
1563.30	V	-53.84	-40.00	-13.84	-57.50	-58.60	4.76

Mode							
LTE Band 13, CB: 5MHz, 1RB, Offset 24, Channel : 23230							
Frequency (MHz)	Antenna Polarity	E.I.R.P. (dBm)	Limit (dBm)	Margin (dB)	S.A Reading (dBm)	S.G Power Vaule (dBm)	Correction Factor (dB)
1568.30	H	-56.49	-40.00	-16.49	-60.13	-61.26	4.77
1568.30	V	-57.30	-40.00	-17.30	-60.67	-62.07	4.77

Mode							
LTE Band 13, CB: 5MHz, 1RB, Offset 24, Channel : 23255							
Frequency (MHz)	Antenna Polarity	E.I.R.P. (dBm)	Limit (dBm)	Margin (dB)	S.A Reading (dBm)	S.G Power Vaule (dBm)	Correction Factor (dB)
1573.30	H	-55.25	-40.00	-15.25	-58.30	-60.04	4.79
1573.30	V	-55.21	-40.00	-15.21	-42.21	-60.00	4.79

Mode							
LTE Band 13, CB: 10MHz, 1RB, Offset 49, Channel : 23230							
Frequency (MHz)	Antenna Polarity	E.I.R.P. (dBm)	Limit (dBm)	Margin (dB)	S.A Reading (dBm)	S.G Power Vaule (dBm)	Correction Factor (dB)
1572.40	H	-56.22	-40.00	-16.22	-59.84	-61.01	4.79
1572.40	V	-57.02	-40.00	-17.02	-60.07	-61.81	4.79

Note: EIRP = S.G Power value + Correction factor.

### 3.3 Conducted Emissions

#### 3.3.1 Limit of Conducted Emissions

On any frequency outside the the licensed band, the power of any emission shall be attenuatedoutside the band below the transmitter power (P) by at least  $43 + 10 \log (P)$  dB equal to -13dBm.

#### 3.3.2 Test Procedures

1. Lowestand highest operating channels are tested for this item.
2. Scan frequency range is from 30 MHz ~ 9 GHz.
3. Set RBW = 1MHz, VBW = 3MHz, detector = RMS, sweep time = auto.
4. Record the max trace value and capture the test plot of each sub frequency band.

#### 3.3.3 Test Setup

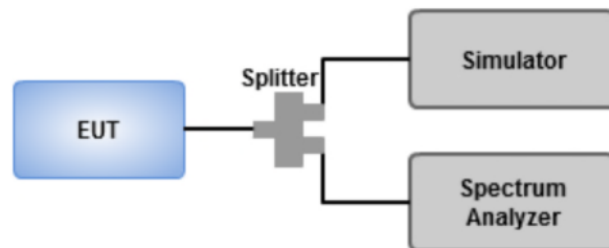

### 3.3.4 Test Result of Conducted Emissions

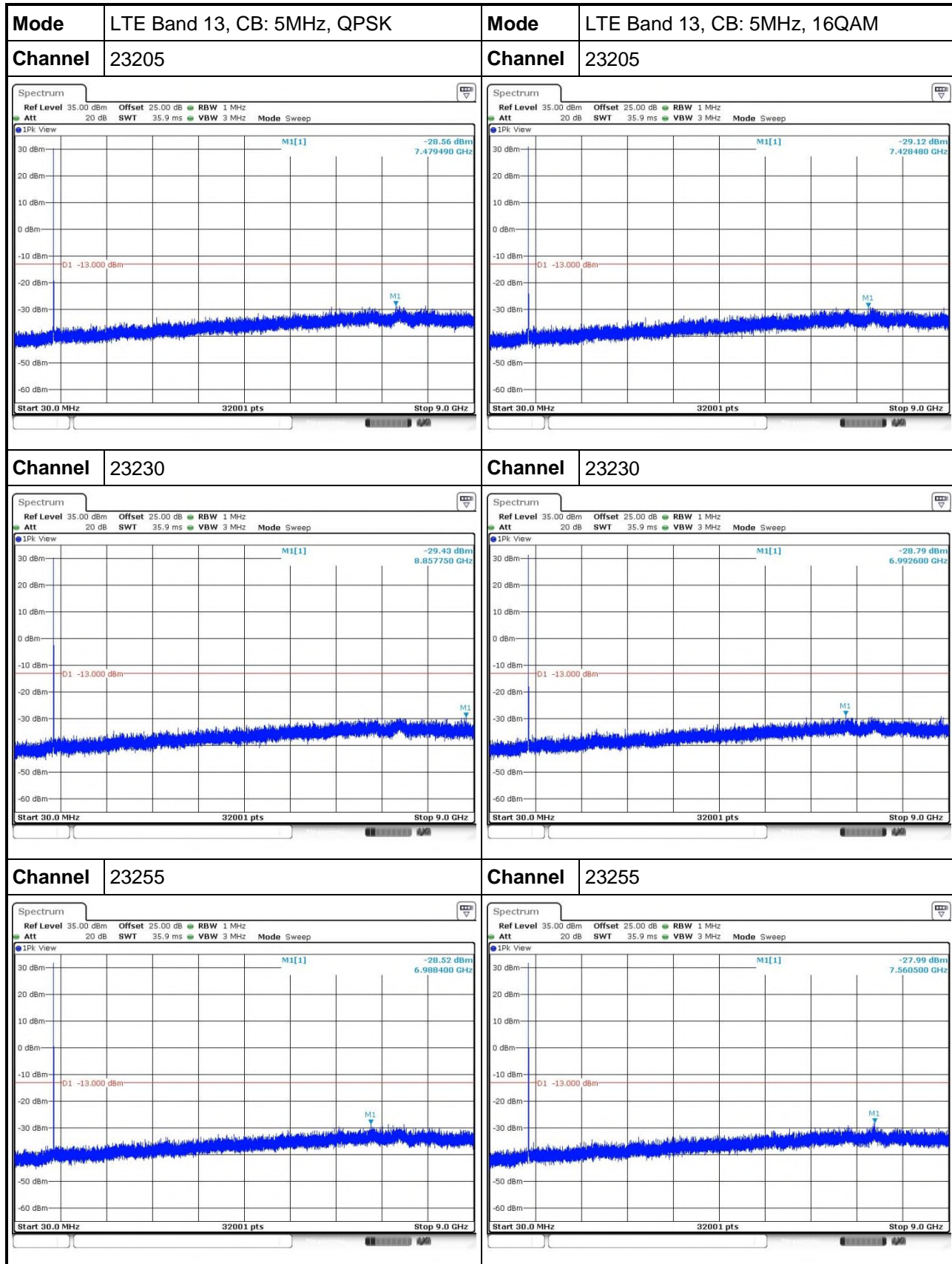

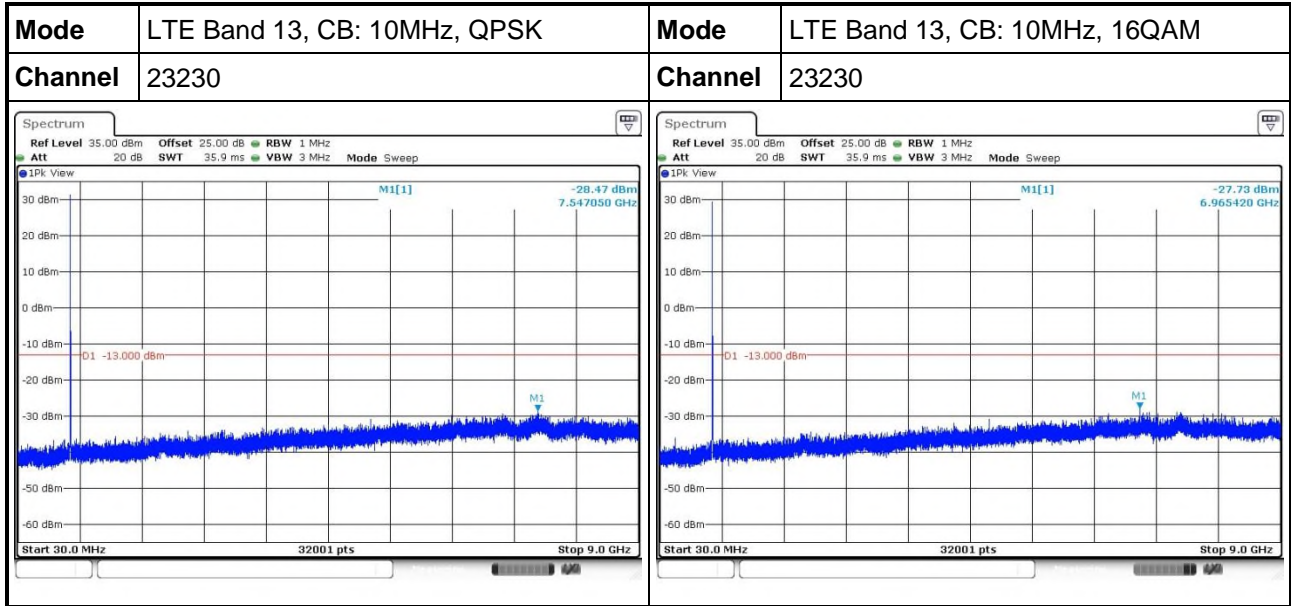

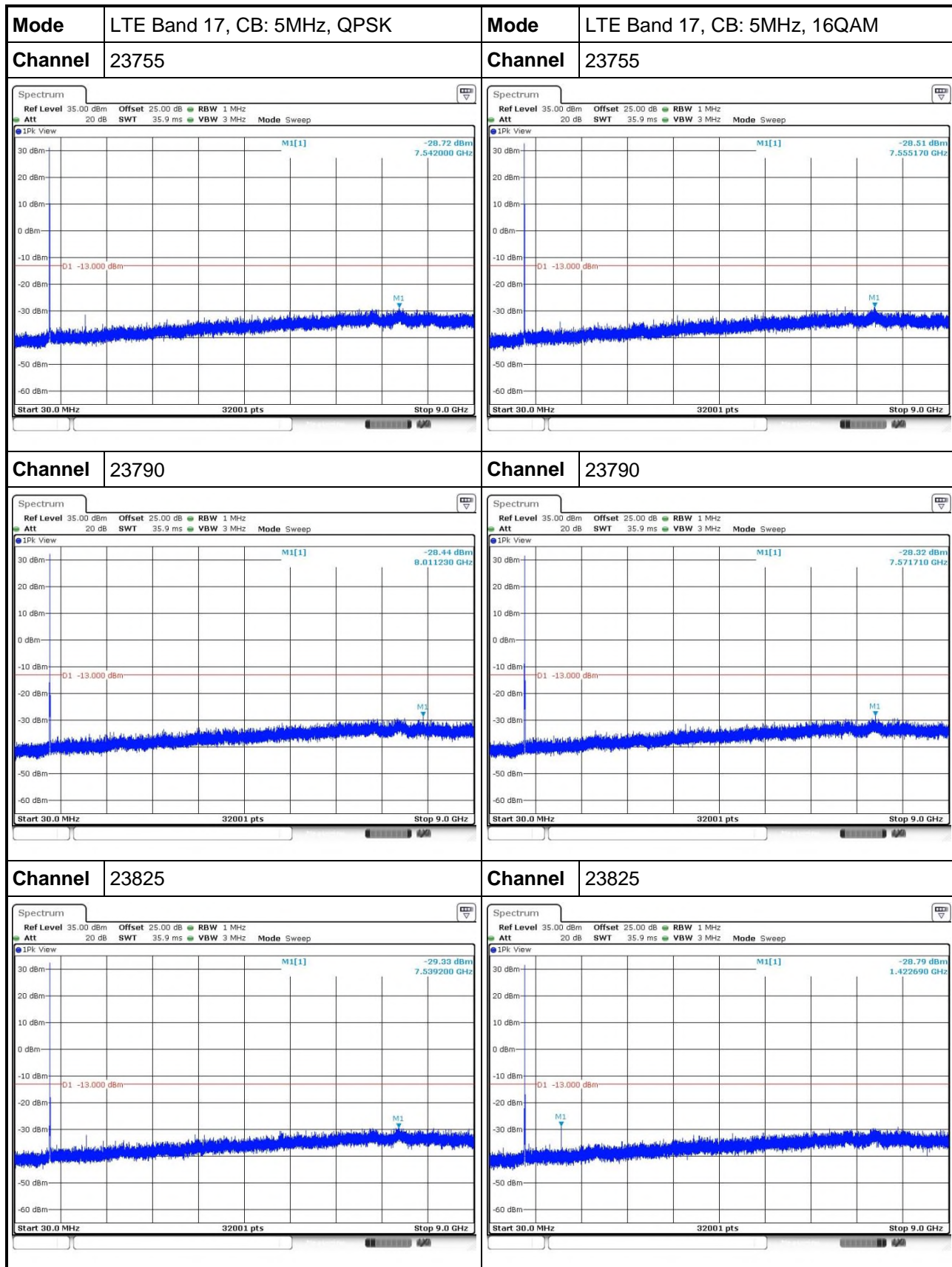



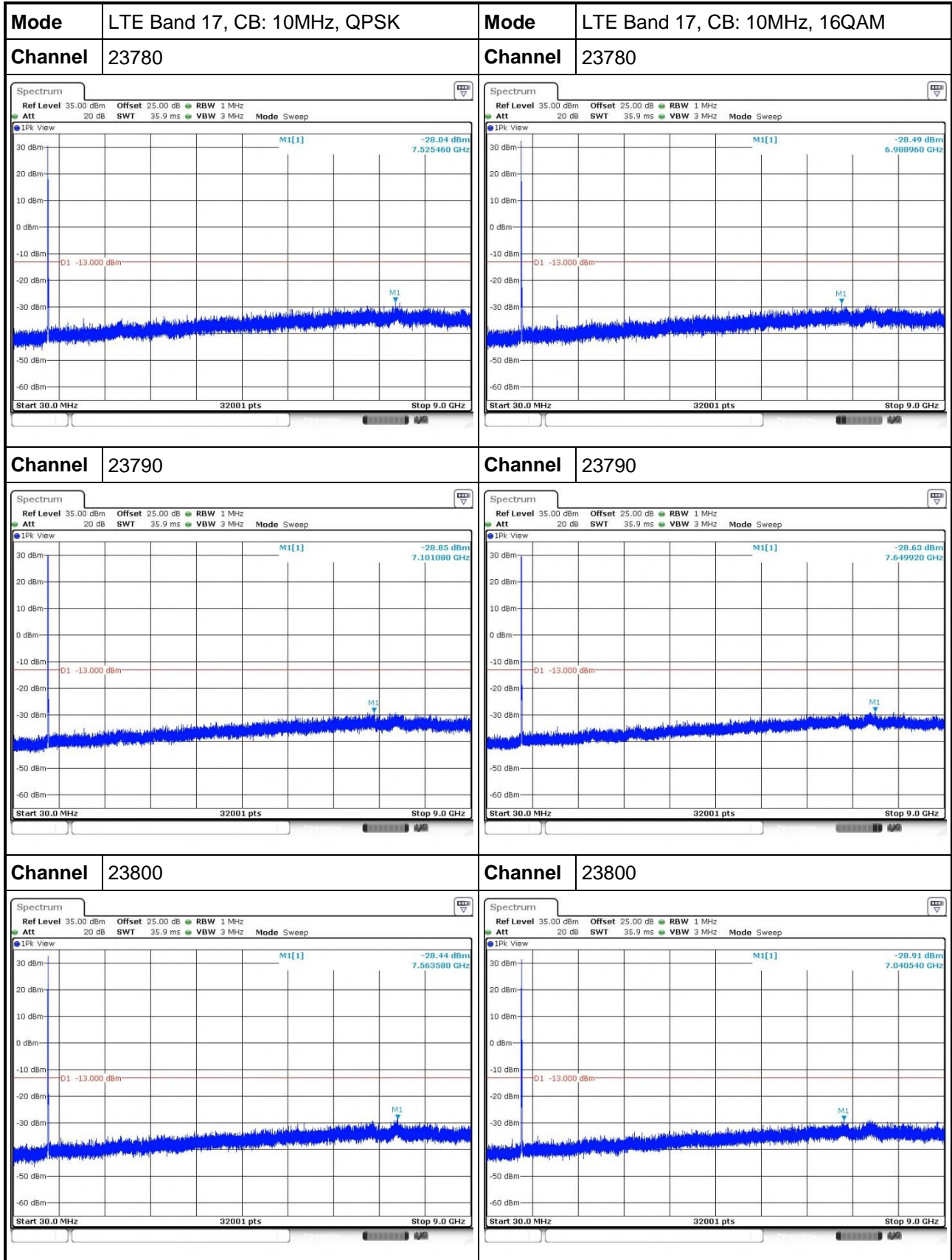

## 3.4 Band Edge

### 3.4.1 Limit of Band Edge

On any frequency outside the licensed band, the power of any emission shall be attenuated outside the band below the transmitter power (P) by at least  $43 + 10 \log(P)$  dB equal to -13dBm.

For operations in the 746-758 MHz band and the 776-788 MHz band, the power of any emission outside the licensee's frequency band(s) of operation shall be attenuated below the transmitter power (P) within the licensed band(s) of operation, measured in watts, in accordance with the following:

On all frequencies between 763~775 MHz and 793~805 MHz, by a factor not less than  $65 + 10 \log(P)$  dB in a 6.25 kHz band segment, for mobile and portable stations.

### 3.4.2 Test Procedures

For frequency range out of 763~775 and 793~805 MHz.

1. Set RBW = 56kHz, VBW = 180kHz, detector = RMS, sweep time = auto for 5MHz channel bandwidth.  
Set RBW = 110kHz, VBW = 330kHz, detector = RMS, sweep time = auto for 10 MHz channel bandwidth.
2. Record the max trace value and capture the test plot.
3. Set RBW = 100 kHz, VBW = 300 kHz, detector = RMS and use channel power measurement function of spectrum analyze to integrate power over 1MHz.

For frequency range 763~775 and 793~805 MHz.

1. Set RBW = 10kHz, VBW = 30kHz, detector = RMS, sweep time = auto.
2. Record the max trace value and capture the test plot.

### 3.4.3 Test Setup

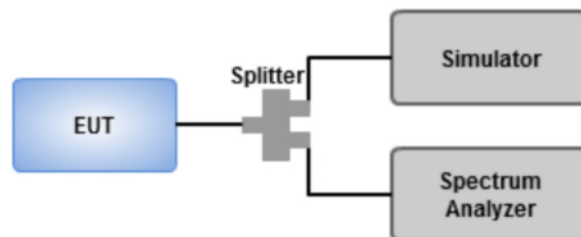

### 3.4.4 Test Result of Band Edge





