

Wireless Display System Instruction Manual

Proof #1
01/15/09



TABLE OF CONTENTS

SAFETY..... Inside Front Cover

 Read This Manual Thoroughly..... 1

 Safety Rules 1

 Operation and Maintenance..... 3

 How to Obtain Service..... 3

INTRODUCTION 3

BATTERY OPERATION 3

INSTALLATION 4

 Generator Side Transceiver Installation Instructions 4

 Display Installation..... 5

THE COMMUNICATIONS LED 6

GENERATOR COMMUNICATIONS 6

THE DISPLAY 6

 Contrast Adjustment 6

 Backlight 6

 Buttons..... 7

 Battery and Signal Strength Indicators..... 7

ALARM AND STATUS DISPLAY 7

THE MENU SYSTEM 7

 Status Menu 8

 Test Menu..... 8

 History Menu..... 8

SETTINGS MENU 9

 Adjust Contrast..... 9

EXERCISE MENU 9

RADIO MENU 9

 Radio Information 9

 Changing Channels..... 9

 Reset Radio 9

 Add New Display 10

 Test Radio Link 10

TIME & DATE MENU 10

GRAPH MENU..... 10

MENU MAP..... 11

FADD ASSEMBLY 12

NOTES..... 13

WARRANTY Back Cover

SAFETY

Compliance Statement (Part 15.19)

This device complies with Part 15 of the FCC Rules.

Operation is subject to the following two conditions:

1. This device may not cause harmful interference, and
2. This device must accept any interference received, including interference that may cause undesired operation.

Warning (Part 15.21)

Changes or modifications not expressly approved by the party responsible for compliance could void the user's authority to operate the equipment.

FCC Interference Statement (Part 15.105 (b))

This equipment has been tested and found to comply with the limits for a Class B digital device, pursuant to Part 15 of the FCC Rules. These limits are designed to provide reasonable protection against harmful interference in a residential installation. This equipment generates uses and can radiate radio frequency energy and, if not installed and used in accordance with the instructions, may cause harmful interference to radio communications. However, there is no guarantee that interference will not occur in a particular installation. If this equipment does cause harmful interference to radio or television reception, which can be determined by turning the equipment off and on, the user is encouraged to try to correct the interference by one of the following measures:

- Reorient or relocate the receiving antenna.
- Increase the separation between the equipment and receiver.
- Connect the equipment into an outlet on a circuit different from that to which the receiver is connected.
- Consult the dealer or an experienced radio/TV technician for help.

To comply with FCC/IC RF exposure limits for general population / uncontrolled exposure, the antenna(s) used for this transmitter must be installed to provide a separation distance of at least 20 cm from all persons and must not be co-located or operating in conjunction with any other antenna or transmitter.

RF Exposure (OET Bulletin 65)

To comply with FCC/IC RF exposure requirements for mobile transmitting devices, this transmitter should only be used or installed at locations where there is at least 20 cm separation distance between the antenna and all persons.

Section 7.1.5 of RSS-GEN

Operation is subject to the following two conditions:

1. This device may not cause interference, and
2. This device must accept any interference, including interference that may cause undesired operation of the device.



 **SAVE THESE INSTRUCTIONS** – The manufacturer suggests that these rules for safe operation be copied and posted in potential hazard areas. Safety should be stressed to all operators, potential operators, and service and repair technicians for this equipment. 

 **SAVE THESE INSTRUCTIONS** – This manual contains important instructions that should be followed during installation and maintenance of the generator and batteries. 

◆ READ THIS MANUAL THOROUGHLY

If any portion of this manual is not understood, contact the nearest Authorized Service Dealer for starting, operating and servicing procedures.

Throughout this publication, and on tags and decals affixed to the generator, DANGER, WARNING, CAUTION and NOTE blocks are used to alert personnel to special instructions about a particular service or operation that may be hazardous if performed incorrectly or carelessly. Observe them carefully. Their definitions are as follows:

 **DANGER** 

After this heading, read instructions that, if not strictly complied with, will result in personal injury or property damage.

 **WARNING** 

After this heading, read instructions that, if not strictly complied with, may result in personal injury or property damage.

 **CAUTION** 

After this heading, read instructions that, if not strictly complied with, could result in damage to equipment and/or property.

NOTE:

After this heading, read explanatory statements that require special emphasis.

These safety warnings cannot eliminate the hazards that they indicate. Common sense and strict compliance with the special instructions while performing the service are essential to preventing accidents.

Four commonly used safety symbols accompany the DANGER, WARNING and CAUTION blocks. The type of information each indicates is as follows:

 This symbol points out important safety information that, if not followed, could endanger personal safety and/or property of others.

 This symbol points out potential explosion hazard.

 This symbol points out potential fire hazard.

 This symbol points out potential electrical shock hazard.

 **WARNING:** 
The engine exhaust from this product contains chemicals known to the state of California to cause cancer, birth defects or other reproductive harm.

 **WARNING:** 
This product contains or emits chemicals known to the state of California to cause cancer, birth defects or other reproductive harm.

Study these SAFETY RULES carefully before installing, operating or servicing this equipment. Become familiar with this Owner's Manual and with the unit. The generator can operate safely, efficiently and reliably only if it is properly installed, operated and maintained. Many accidents are caused by failing to follow simple and fundamental rules or precautions.

The manufacturer cannot anticipate every possible circumstance that might involve a hazard. The warnings in this manual, and on tags and decals affixed to the unit are, therefore, not all inclusive. If using a procedure, work method or operating technique that the manufacturer does not specifically recommend, ensure that it is safe for all personnel. Also make sure the procedure, work method or operating technique utilized does not render the generator unsafe.

 **DANGER** 

 Despite the safe design of this generator, operating this equipment imprudently, neglecting its maintenance or being careless can cause possible injury or death. Permit only responsible and capable persons to install, operate or maintain this equipment.

 Potentially lethal voltages are generated by these machines. Ensure all steps are taken to render the machine safe before attempting to work on the generator.

 Parts of the generator are rotating and/or hot during operation. Exercise care near running generators.



⚠ GENERAL HAZARDS ⚠

- For safety reasons, the manufacturer recommends that this equipment be installed, serviced and repaired by an Authorized Service Dealer or other competent, qualified electrician or installation technician who is familiar with applicable codes, standards and regulations. The operator also must comply with all such codes, standards and regulations.
- Installation, operation, servicing and repair of this (and related) equipment must always comply with applicable codes, standards, laws and regulations. Adhere strictly to local, state and national electrical and building codes. Comply with regulations the Occupational Safety and Health Administration (OSHA) has established. Also, ensure that the generator is installed, operated and serviced in accordance with the manufacturer's instructions and recommendations. Following installation, do nothing that might render the unit unsafe or in noncompliance with the aforementioned codes, standards, laws and regulations.
- The engine exhaust fumes contain carbon monoxide gas, which can be DEADLY. This dangerous gas, if breathed in sufficient concentrations, can cause unconsciousness or even death. For that reason, adequate ventilation must be provided. Exhaust gases must be piped safely away from any building or enclosure that houses the generator to an area where people, animals, etc., will not be harmed. This exhaust system must be installed properly, in strict compliance with applicable codes and standards.
- Keep hands, feet, clothing, etc., away from drive belts, fans, and other moving or hot parts. Never remove any drive belt or fan guard while the unit is operating.
- Adequate, unobstructed flow of cooling and ventilating air is critical in any room or building housing the generator to prevent buildup of explosive gases and to ensure correct generator operation. Do not alter the installation or permit even partial blockage of ventilation provisions, as this can seriously affect safe operation of the generator.
- Keep the area around the generator clean and uncluttered. Remove any materials that could become hazardous.
- When working on this equipment, remain alert at all times. Never work on the equipment when physically or mentally fatigued.
- Inspect the generator regularly, and promptly repair or replace all worn, damaged or defective parts using only factory-approved parts.
- Before performing any maintenance on the generator, disconnect its battery cables to prevent accidental start-up. Disconnect the cable from the battery post indicated by a NEGATIVE, NEG or (-) first. Reconnect that cable last.
- Never use the generator or any of its parts as a step. Stepping on the unit can stress and break parts, and may result in dangerous operating conditions from leaking exhaust gases, fuel leakage, oil leakage, etc.

⚡ ELECTRICAL HAZARDS ⚡

- All generators covered by this manual produce dangerous electrical voltages and can cause fatal electrical shock. Utility power delivers extremely high and dangerous voltages to the transfer switch, as does the standby generator. Avoid contact with bare wires, terminals, connections, etc., on the generator as well as the transfer switch, if applicable. Ensure all appropriate covers, guards and barriers are in place before operating the generator. If work must be done around an operating unit, stand on an insulated, dry surface to reduce shock hazard.
- Do not handle any kind of electrical device while standing in water, while barefoot, or while hands or feet are wet. **DANGEROUS ELECTRICAL SHOCK MAY RESULT.**
- If people must stand on metal or concrete while installing, operating, servicing, adjusting or repairing this equipment, place insulative mats over a dry wooden platform. Work on the equipment only while standing on such insulative mats.
- The National Electrical Code (NEC), Article 250 requires the frame and external electrically conductive parts of the generator to be connected to an approved earth ground and/or grounding rods. This grounding will help prevent dangerous electrical shock that might be caused by a ground fault condition in the generator set or by static electricity. Never disconnect the ground wire.
- Wire gauge sizes of electrical wiring, cables and cord sets must be adequate to handle the maximum electrical current (ampacity) to which they will be subjected.
- Before installing or servicing this (and related) equipment, make sure that all power voltage supplies are positively turned off at their source. Failure to do so will result in hazardous and possibly fatal electrical shock.
- Connecting this unit to an electrical system normally supplied by an electric utility shall be by means of a transfer switch so as to isolate the generator electric system from the electric utility distribution system when the generator is operating. Failure to isolate the two electric system power sources from each other by such means, will result in damage to the generator and may also result in injury or death to utility power workers due to backfeed of electrical energy.
- Generators installed with an automatic transfer switch will crank and start automatically when normal (utility) source voltage is removed or is below an acceptable preset level. To prevent such automatic start-up and possible injury to personnel, disable the generator's automatic start circuit (battery cables, etc.) before working on or around the unit. Then, place a "Do Not Operate" tag on the generator control panel and on the transfer switch.
- In case of accident caused by electric shock, immediately shut down the source of electrical power. If this is not possible, attempt to free the victim from the live conductor. **AVOID DIRECT CONTACT WITH THE VICTIM.** Use a nonconducting implement, such as a dry rope or board, to free the victim from the live conductor. If the victim is unconscious, apply first aid and get immediate medical help.
- Never wear jewelry when working on this equipment. Jewelry can conduct electricity resulting in electric shock, or may get caught in moving components causing injury.

FIRE HAZARDS

- Keep a fire extinguisher near the generator at all times. Do NOT use any carbon tetra-chloride type extinguisher. Its fumes are toxic, and the liquid can deteriorate wiring insulation. Keep the extinguisher properly charged and be familiar with its use. If there are any questions pertaining to fire extinguishers, consult the local fire department.

EXPLOSION HAZARDS

- Properly ventilate any room or building housing the generator to prevent build-up of explosive gas.
- Do not smoke around the generator. Wipe up any fuel or oil spills immediately. Ensure that no combustible materials are left in the generator compartment, or on or near the generator, as FIRE or EXPLOSION may result. Keep the area surrounding the generator clean and free from debris.
- These generator sets may operate using one of several types of fuels. All fuel types are potentially FLAMMABLE and/or EXPLOSIVE and should be handled with care. Comply with all laws regulating the storage and handling of fuels. Inspect the unit's fuel system frequently and correct any leaks immediately. Fuel supply lines must be properly installed, purged and leak tested according to applicable fuel-gas codes before placing this equipment into service.
- Diesel fuels are highly FLAMMABLE. Gaseous fluids such as natural gas and liquid propane (LP) gas are extremely EXPLOSIVE. Natural gas is lighter than air, and LP gas is heavier than air; install leak detectors accordingly.

OPERATION AND MAINTENANCE

The operator is responsible for proper and safe use of the equipment. The manufacturer strongly recommends that the operator read this Owner's Manual and thoroughly understand all instructions before using this equipment. The manufacturer also strongly recommends instructing other users to properly start and operate the unit. This prepares them if they need to operate the equipment in an emergency.

It is the operator's responsibility to perform all safety checks, to make sure that all maintenance for safe operation is performed promptly, and to have the equipment checked periodically by an Authorized Service Dealer. Normal maintenance service and replacement of parts are the responsibility of the owner/operator and, as such, are not considered defects in materials or workmanship within the terms of the warranty. Individual operating habits and usage contribute to the need for maintenance service.

Proper maintenance and care of the generator ensures a minimum number of problems and keeps operating expenses at a minimum. See an Authorized Service Dealer for service aids and accessories.

Operating instructions presented in this manual assume that the standby electric system has been installed by an Authorized Service Dealer or other competent, qualified contractor. Installation of this equipment is not a "do-it-yourself" project.

HOW TO OBTAIN SERVICE

When the generator requires servicing or repairs, contact an Authorized Service Dealer for assistance. Service technicians are factory-trained and are capable of handling all service needs (1-800-333-1322).

When contacting an Authorized Service Dealer about parts and service, always supply the complete model number of the unit as given on the front cover of this manual or on the DATA LABEL affixed to the unit.

INTRODUCTION

The wireless display system consists of two identical radio transceivers, one mounted near the generator and the other (the one with the display), should be in a convenient viewing location. The system has a "line of sight" range of about 500 feet but this will be reduced if the signal has to go through walls, etc.. The display is intended to show the status of the generator and warn you if the system is in an alarm state. It also provides the following additional functions:

- An independent (of the generator Alarm log) time/date stamped history of generator events such as starting and stopping
- Allows remote starting and stopping of the generator
- Facility to set an exercise time and day from the display
- A separate battery backed clock (with date facility) which is synchronized to the generator clock. If power is removed from the generator, time and date can be automatically restored from this clock.
- Ability to add extra displays
- Graphing capability

The unit can be either battery powered or fed from the AC adapter supplied (Part No. OG4904). This adapter is rated for 100/240 VAC, 50/60 Hz operation. The History is kept in permanent memory that is not lost even when all power is lost. The clock function is kept alive by a separate, 10 year life battery.

BATTERY OPERATION

The wireless display can be operated either from a plug in wall transformer or from three AAA alkaline batteries. The unit is NOT designed to run continuously on battery power. The batteries can be rechargeable but are NOT recharged from the wall transformer and should be separately charged. In the case of battery operation, the unit will go to sleep for 60 seconds then exchange data for up to two (2) seconds to conserve battery life. The display screen will turn off in the sleep mode unless there is an alarm to be displayed. It can be awoken by pressing the ENTER key after which it will remain awake for one (1) minute if no further keys are pressed. The batteries are NOT used to retain data such as the history log or the radio settings, they will not be lost in the event of a dead battery.

NOTE 1:

In battery sleep mode it will take up to two (2) minutes to detect if the radio link is lost. This long delay is to allow for the unit's sleep time.

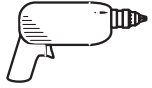

NOTE 2:

In battery sleep mode, if the wall transformer is plugged into the unit, it will take up to one minute to recognize this fact.

INSTALLATION

◆ GENERATOR SIDE TRANSCEIVER INSTALLATION INSTRUCTIONS

The following steps will illustrate how to mount the generator side transceiver to the generator.

⚠ WARNING ⚠

⚠ Disconnect all power sources prior to opening the control panel.

1. Set the Auto/Off/Manual switch to the Off position.
2. Remove the 15Amp control panel fuse.
3. Disconnect the Positive battery cable.
4. Turn off the 240Vac Utility source voltage to the control panel.
5. Remove the control panel cover.
6. Remove the metal plate and rubber gasket from the back side of the generator. (Figure 1.)

Figure 1 — Remove Metal Plate & Rubber Gasket

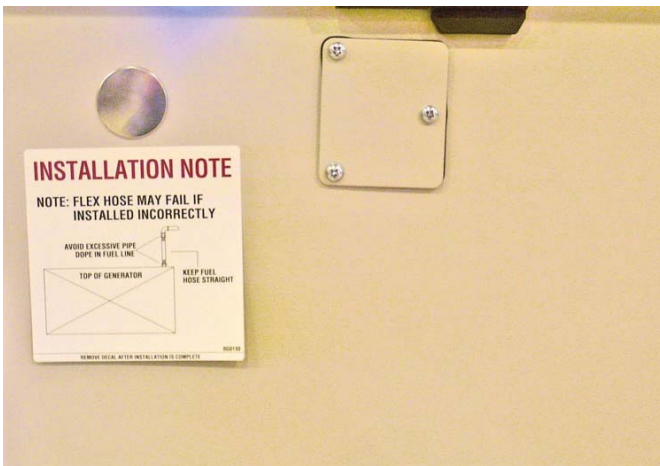

7. Remove the generator transceiver from the anti static bag and verify the gasket is properly fitted in the groove.
8. Mount the generator transceiver to the generator using the two (2) screws and flat washers provided (Figure 2).
9. Plug the wire harness into the transceiver module aligning the plug latch with the header latch (Figure 3).

NOTE:

The plug will only plug into the header one way – DO NOT force the plug into the header; gently insert the plug until it locks into place.

Figure 2 — Mount Transceiver



Figure 3 — Plug in Wire Harness



10. Undo the four (4) screws holding the control panel and raise up the front end of the control panel so it's standing up (Figure 4).

Figure 4 — Stand Up Control Panel Front



11. Plug the other end of the wire harness into the 8-way connector at the top of the control panel. The plug will only plug in one way (Figure 5). **DO NOT force the plug into the header. Gently insert the plug until it locks into place.**

Figure 5 — Plug Wire Harness into Header J5



12. Route the wire in the channel along the left hand wall along with the other wires (Figure 6).

Figure 6 — Route Wire

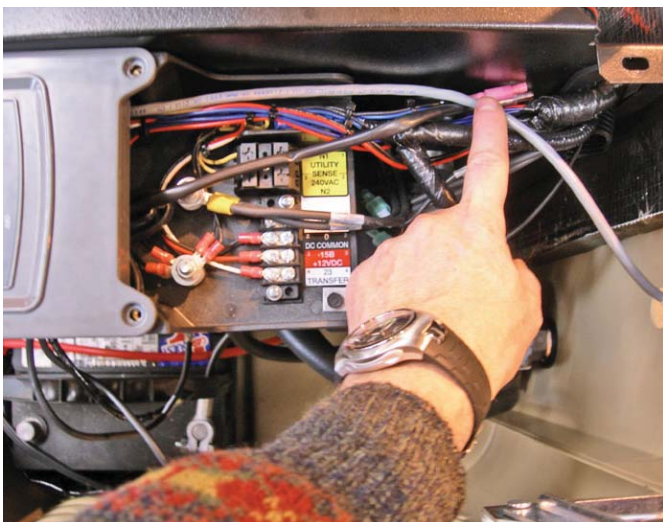

13. Replace the control panel front.
14. Replace the control panel cover.
15. Turn on the 240Vac Utility source voltage.
16. Reconnect the positive battery cable.
17. Replace the 15Amp control panel fuse.

◆ DISPLAY INSTALLATION

For easier installation, the batteries should first be fitted into the display unit (Figure 7). This will allow you to walk around and find the best location for the unit while still receiving good signal strength. Attach the other transceiver to the generator as described in the previous section.

Figure 7 — Open Display Unit



1. Insert the batteries (Figure 8).

Figure 8 — Insert Batteries



2. Reset the generator control panel by removing the fuse on the front cover and then replace it. **PERFORM STEP 3 IMMEDIATELY AFTER.**
3. **IMMEDIATELY** turn on the generator display, up to one minute will pass while the generator tries to find it's display.

4. The display will show that it is searching for the generator and the yellow LED may flash occasionally as it receives data from the generator transceiver. This is due to the unit searching for the correct channel.
5. Once the generator is found, the radio link is now established and the settings will be remembered next time the display unit is turned on. If the generator is not found, an error message will briefly be shown, and the yellow LED will flash at one (1) second intervals to indicate the display unit was unable to find the generator. Repeat steps 2 and 3 with the Display closer to the generator.
6. If the generator is not talking to it's transceiver, but the radios are talking to each other, this will be indicated by an appropriate alarm which will be displayed after a 30 second period. Check the wiring and connection to the generator.
7. Place the display at the preferred location. Do not permanently mount it yet.
8. Plug the wall transformer into the display so as not to use up the batteries. Familiarize personnel with the radio menu (by reading the manual in conjunction with operating the display).
9. Monitor the signal strength by looking at the display of signal strength bars on the display (Figure 11). Note that it takes a few seconds for the display to update the signal strength display. Relocate the display if the signal strength is poor or non-existent.
10. Mount the display using the holes on the back to hang onto two suitably sized fixing screws in the drywall 2¼ inches apart. It should be vertically mounted on a wall BETWEEN studs for maximum signal strength (Figure 9).

Figure 9 — Mounting Holes

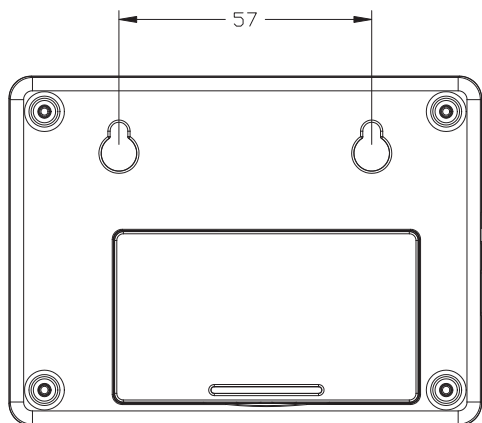

11. Once a link is established, the display will "remember" it's own generator and will not need to search for it again after it is turned off and back on. If the battery is ever disconnected at the generator end, the generator will search for the display when the battery is reconnected. **It is important that the display is powered from the wall transformer at this time and not it's internal battery. This is because the display would normally be in sleep mode when powered from it's battery and the generator would be unable to find it.**

12. Set the time and date into the clock, use the instructions given in the "Time and Date Menu" section. The time and date will be remembered even if the battery goes dead. There is a separate, replaceable 10 year battery for this function.
13. The communications LED will light solid to show data is being received. A flashing LED indicates the unit was unable to find the generator.
14. Set an exercise day and time now (see "Exercise Menu" section).

THE COMMUNICATIONS LED

The communications LED will light solid to show data is being received. If the LED flashes at regular one (1) second intervals, it indicates the unit was unable to find the generator. Irregular flashing is an indication of poorer reception.

GENERATOR COMMUNICATIONS

The transceiver requests data from the generator every two (2) seconds and this is stored inside the transceiver locally. The data is relayed to the base station over the radio link every time it is requested by the display about every two (2) seconds. When on battery power, the data is only requested every minute to conserve batteries. If the generator is not talking to it's transceiver, but the radios are talking to each other, this will be indicated by an appropriate alarm which will be displayed after a seven (7) second period (Figure 10). Check the wiring and connection to the generator.

Figure 10 — Sample Alarm

WARNING

RADIO OK
BUT GEN
IS NOT
TALKING

THE DISPLAY

◆ CONTRAST ADJUSTMENT

The display contrast can be adjusted from the "Settings" menu. Any changes to the contrast setting will be remembered even if power is removed from the display.

◆ BACKLIGHT

The backlight is lit whenever a key is pressed. It will remain lit for 20 seconds if there are no further key presses. If an alarm occurs, the backlight will flash at a one (1) second rate (not if battery powered).

◆ BUTTONS

Operation of the display is controlled by three (3) buttons labeled +, —, and Enter. These buttons are used to navigate the display to the required page, or to enter data. The +/— buttons are also referred to as the arrow keys. Holding down a button for more than half a second will cause it to auto repeat until it is released.

◆ BATTERY AND SIGNAL STRENGTH INDICATORS

In the top left corner of the display, there are two icons (or pictures) that give a quick indication of the state of the internal battery and the radio signal strength (Figure 11). The battery is represented by the left hand, single tall rectangle which is drawn as being somewhere between full and empty. Full represents greater than 75% capacity, mostly full represents 50-75% capacity, half full represent 25-50% and mostly empty represents 0-25% capacity. The signal strength icon is shown to the right of the battery icon as three vertical bars representing greater than 25%, greater than 50%, and greater than 75%. Three bars indicate excellent signal strength, two bars represent good signal strength, one bar represents weak signal strength. Two or three bars is the normal indication.

Figure 11 — Battery & Signal Strength

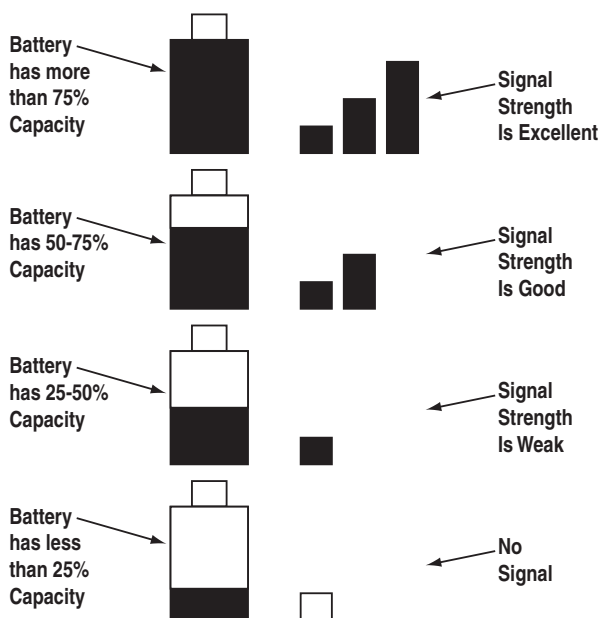

ALARM AND STATUS DISPLAY

The display will normally show the operating status of the generator or an alarm message if one is present. See Figures 12 and 13.

Figure 12 — Sample Alarm Screen

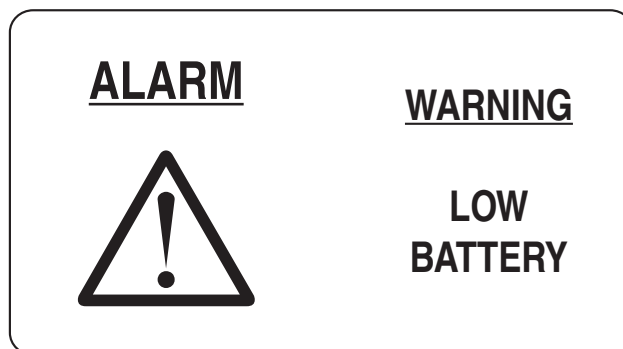

Figure 13 — Sample Status Screen



When a key is pressed, the display switches into menu mode which will allow access to the special functions of the unit. If no keys are pressed for 30 seconds, the unit will revert back to the status or alarm display.

When an alarm occurs, the display will show a flashing alarm icon and the alarm message. The backlight will also flash if not in battery mode. If the alarm goes away, the display will revert to the status display. If two or more alarms exist, the most recent one to occur will be displayed. If a key is pressed to go into menu mode, when returning to the alarm display, the latest alarm will be displayed.

THE MENU SYSTEM

Pressing any key will switch the display into menu mode (Figure 14). If no further keys are pressed for one minute, the unit will revert back to the status display. Menu Mode is indicated by a menu name on the right side of the display, and an icon (picture) on the left side. Use the up/down arrow keys to move to the menu required, then press the enter key to see the choices.

Figure 14 — Menu System

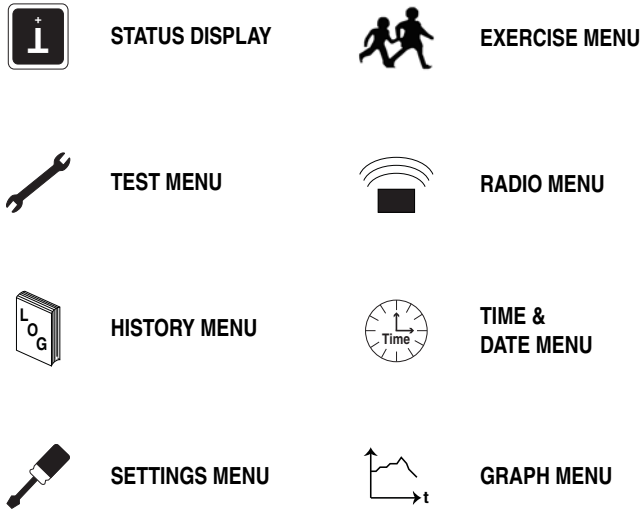

Once a menu is selected, there will be a list of choices. The current choice is shown by a rectangle drawn around it (Figure 15). Use the arrow keys to navigate the rectangle to the topic required, then press the enter key.

Figure 15 — Menu Choices

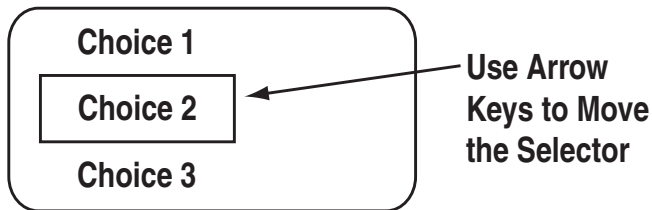

◆ **STATUS MENU**



The status menu item simply provides a way to show the current status message coming from the generator. This is shown as a text message on the LEFT hand side of the display. Normally this will show the following message: "READY TO RUN".

◆ **TEST MENU**



The test menu permits starting and stopping the generator. Use the arrow keys to navigate to the appropriate option. If choosing to start the generator, the two arrow keys will need to be pressed together to confirm the command. To cancel the command, press the enter key.

If the generator can run at a low speed (Quiet Test QT), this option is available. If there is an automatic transfer switch, there is the option to run the generator and transfer onto generator power. Once the generator is started or stopped, the state of the generator will be shown by a "*" symbol next to the command issued.

For example:

Normal Start*	You started the generator at normal speed.
Start & transfer*	You started the generator & transferred to generator power
Low speed start*	You started the generator at low speed (Quiet Test)
Stop generator*	You stopped the generator

There is a one minute cool down time after you stop the generator, so it will continue to operate for one minute after the stop command is issued. In the event that the stop command fails (such as if you take the display out of range, you can either retry the stop command or manually stop the generator by switching it to the "off" position.

◆ **HISTORY MENU**



The history log is a chronological list of "events" that have occurred to the generator. An event is any change in status such as an alarm, a start or stop, the key switch being operated, etc.. These events are permanently stored inside the display module along with a time and date stamp when they occurred. They will not be lost even if the battery goes dead, but there is the option to erase the log. This log is independent of the log displayed at the generator and will log ALL events, not just alarms.

When entering the history menu, the most recently logged event (Event 1) will be displayed. The actual event will be shown as a message on the left hand portion of the screen (Figure 16). The time and date of the event will be shown on the right hand part of the screen, and the event number displayed on the underlined title bar. By using the arrow keys, navigate through the events which are stored in chronological order. Event 1 is the most recent and event 100 is the oldest. The events are stored in a circular fashion so it's possible to scroll from Event 1 back to event 100 by using the "UP" arrow key. The history log can be cleared from the "SETTINGS" menu.

Figure 16 — History Menu

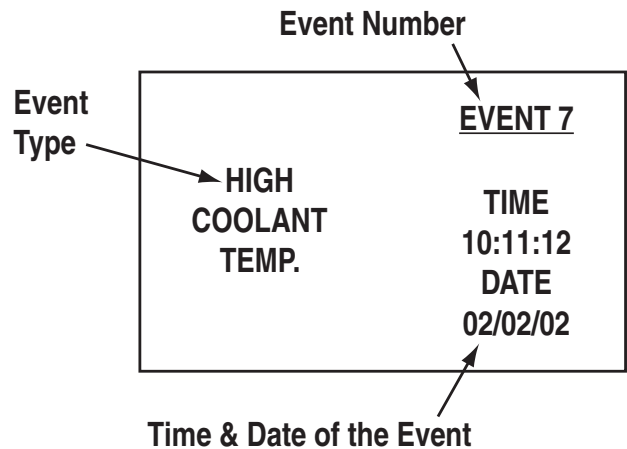

SETTINGS MENU



The following list of options will be presented:

- Adjust Contrast
- Clear History
- Add Me to Network.

◆ ADJUST CONTRAST

The display contrast can be adjusted using the two arrow keys. Once the desired contrast level is reached, press the enter key to store it.

EXERCISE MENU



Normally the exercise time is set at the generator control board. If an exercise time has not been set on the control board, it will flash an alarm message and an alarm will also be set on the wireless display – “EXERCISE TIME NOT SET”.

The exercise page of the wireless display can be used to overwrite any exercise time set in the generator. Use the arrow keys and follow the on-screen instructions to set the time and day of the exercise. The data will be sent to the generator. Confirm it by rechecking the exercise time on the base station display after a few seconds (it takes a few seconds for the radio to update its data).

The wireless display calculates the difference in time from the exercise date and time to the current date and time, and downloads this to the generator. This means the clock on the generator and the clock in the base station must be synchronized, this is normally the case and it is automatically checked and corrected every ten minutes. The exercise cycle is repeated at the same time weekly and does not use the wireless system to do this, all the timing is in the generator.

RADIO MENU



The following list of options will be presented:

- Radio information
- Change Channel
- Reset Radio
- Add New Display
- Test Radio Link

◆ RADIO INFORMATION

This selection shows statistics about the radio link. There is a display of signal quality as a percentage, as well as an indication of the current system channel. For ease of use, the display will NOT revert to the status/alarm screen after one minute if no keys are pressed.

If the signal quality is low but the signal strength is good, there may be some interference. See the section on “Changing Channels”.

◆ CHANGING CHANNELS

Channel selection is normally automatic, manually changing channels should only need to be done if experiencing interference from other equipment. This can be identified by looking at the signal strength and the signal quality. If the signal strength is good but the quality is not, there may be some interference. Changing channels on the main display will automatically change the channel on the generator end provided a link has been established. If the “change channel” message fails for any reason, the units will revert to their old channel selection. A new channel setting will be remembered for the next time the unit is powered up. To change channels on an established and working link, simply select “Change Channel” from the Radio menu, then enter a new channel number.

Changing the channel number on a link that is not established is a little more complex, the only reason this may need to be done is if a link cannot be establish because the default channel is noisy. To perform this task, follow these instructions:

1. Remove power from the generator end of the link by holding in the “Set Exercise” button. Perform steps 2, 3 and 4 while holding this button in. It may be easier to have someone help for these steps.
2. Go to the radio menu and select “Reset radio”. This will try and establish a link but it will fail, the process will take about one minute.
3. Go to the “Change Channel” menu and select a new channel. There are 16 channels to choose from.
4. Go back and select the “Reset Radio” command.
5. Release the “Set Exercise” button to reapply power at the generator end of the link.
6. The radio link should establish itself on the channel selected. This will be remembered even when the power is turned off to the display.

If the unit is a secondary display, no checking is done to ensure the channel matches the current system channel. Set the channel to the current system channel. Look on the main display and select the radio menu, then select “Radio Information”. This will tell you the current channel that is being used.

◆ RESET RADIO

Normally the system will set itself up out of the box. However, if either of the transceivers need to be replaced (the display or the generator end), you will need to re-train the system and re-set the exercise time. You will NOT have to re-train the system if the battery in the display is discharged, the system will remember the radio settings.

If communications are totally lost for an unexplained reason, you may want to perform a new radio setup.

1. Carry the display to a point near the generator and turn it on. Go to the radio menu.
2. Remove the power from the generator control panel by pulling out the fuse on the top of the panel. This is the fuse above the display and next to the Auto/Off/Manual switch on the generator. Immediately replace the fuse. You now have one (1) minute to complete the setup process.

3. On the display select "Reset Radio". The display will show it is searching for the generator, this process will last up to one (1) minute and a countdown timer will be displayed.
4. Once the time is up a message will be displayed showing that the generator has been found. The radio settings will be remembered for the next time.
5. Re-set the exercise time.

◆ ADD NEW DISPLAY

An extra remote display can be added to the network. Each display needs to be trained as to what it's network consists of. This is the function of the "Add New Display" selection.

1. Locate the new display near the main display and turn it on.
2. On the NEW display, go to the "Settings" menu and select "Add me to Network".
3. Choose a unique address for the additional display, for example one that does not conflict with any other additional displays. If there are only two displays, then any number (other than zero), will do. Zero is used to cancel the command.
4. On the MAIN display go to the radio menu and select "Add New Display". Press enter on both displays. A countdown timer will be displayed as the two units re-train.
5. At the end of the period, the new display will show that the training was successful.

◆ TEST RADIO LINK

This feature allows the "basic" data integrity of the link to be tested, it may not be necessary to use this feature. For ease of use, the display will NOT revert to the status/alarm screen after one minute if no keys are pressed.

Test data is sent over the link to the generator end, and then sent back from the generator end to the display. The data received is displayed on the bottom line of the display. Good data is shown as a series of forward slashes (/////). Time-outs on the link are displayed as the "#" character and corrupted data reply messages are shown as the "@" character. The messages are termed "basic" because they are not error checked or corrected.

Radio information such as channel number and quality are also shown alongside the test data.

TIME & DATE MENU



There is a live, updating display of the current time, day, and date shown on the menu icon page (Figure 17).

Figure 17 — Time & Date Menu

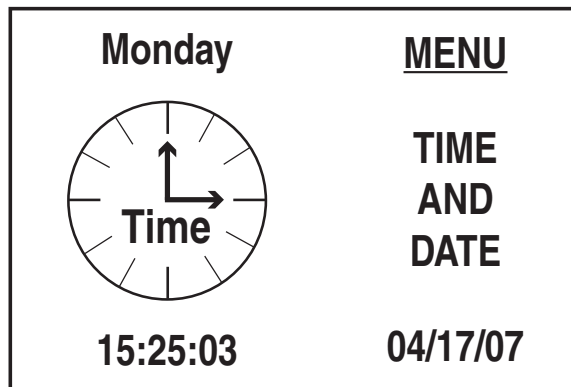

Selecting this menu permits setting the clock to the correct time, day and date. This will only need to be done the first time the base station is powered up, or to correct any small errors in the time. Use the two arrow keys to set the correct time, day and date.

The separate clock in the generator is synchronized to this clock when it is changed. Synchronization is checked and corrected, if necessary, every ten minutes. If the clock or date is changed at the generator, the clock at the base station is also changed automatically (The two clocks are linked together and can be changed at either end of the link).

GRAPH MENU



The Graph menu permits graphing data in real time on a rolling screen (Figure 18). Choose what to graph from the following list:

- Utility Voltage
- Generator Battery Volts
- Generator RPM (in units of RPM x 100)

The display is updated with a new point every 200ms so it takes about 25 seconds to scroll the whole screen. However new data is only read from the generator every two (2) seconds.

Figure 18 — Sample Graph of Engine RPM

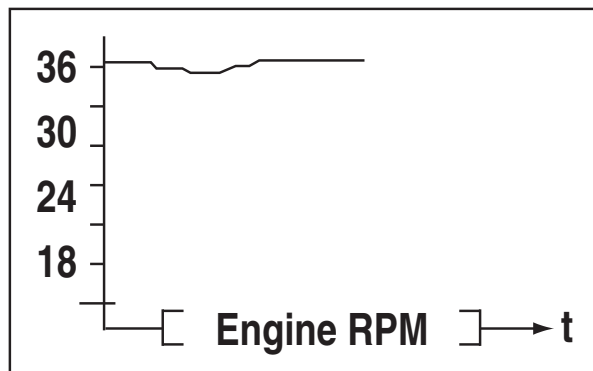

MENU MAP

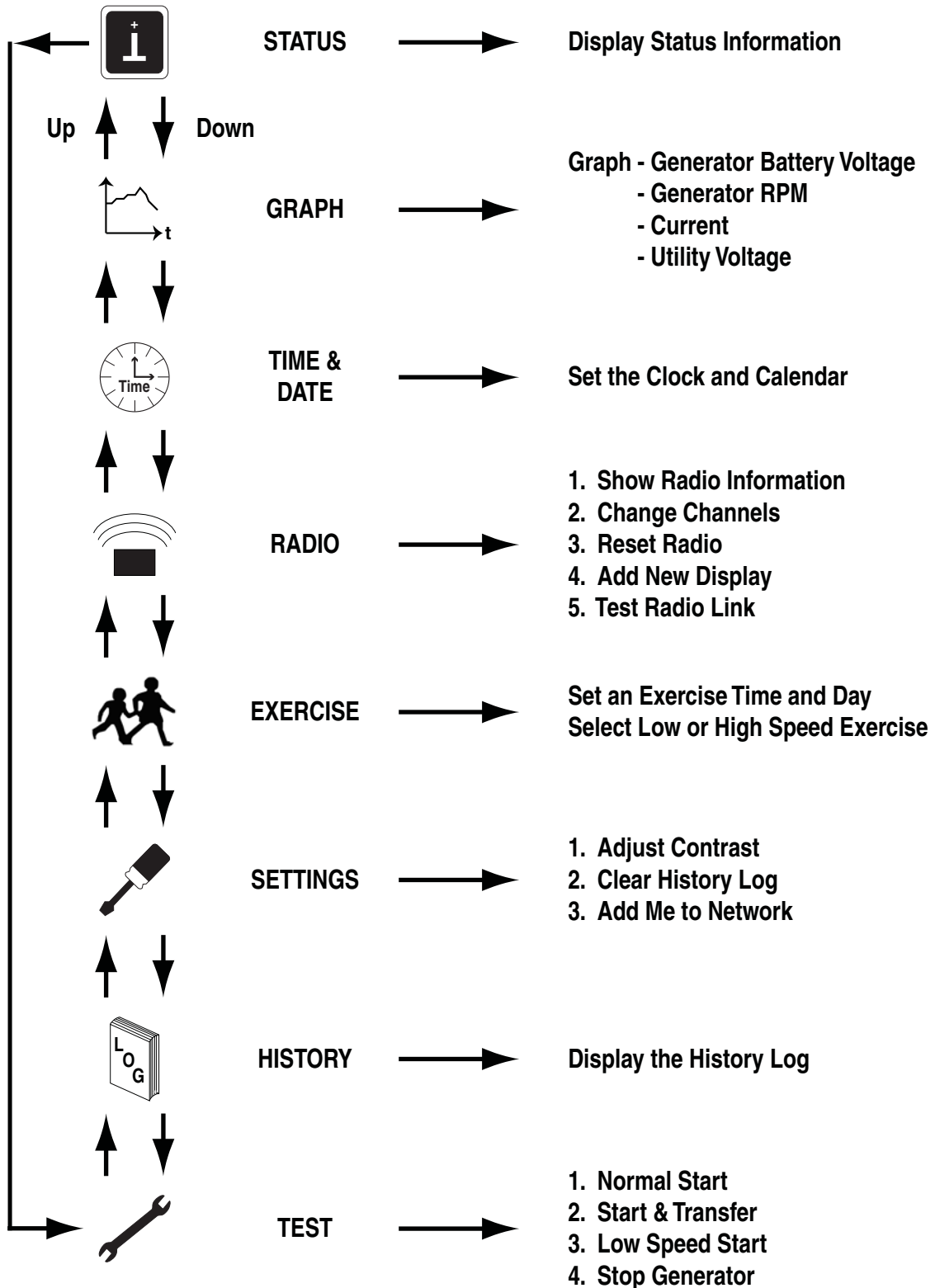



Exploded Views and Parts Lists

Fadd Assembly – Drawing No. 0G8855-B

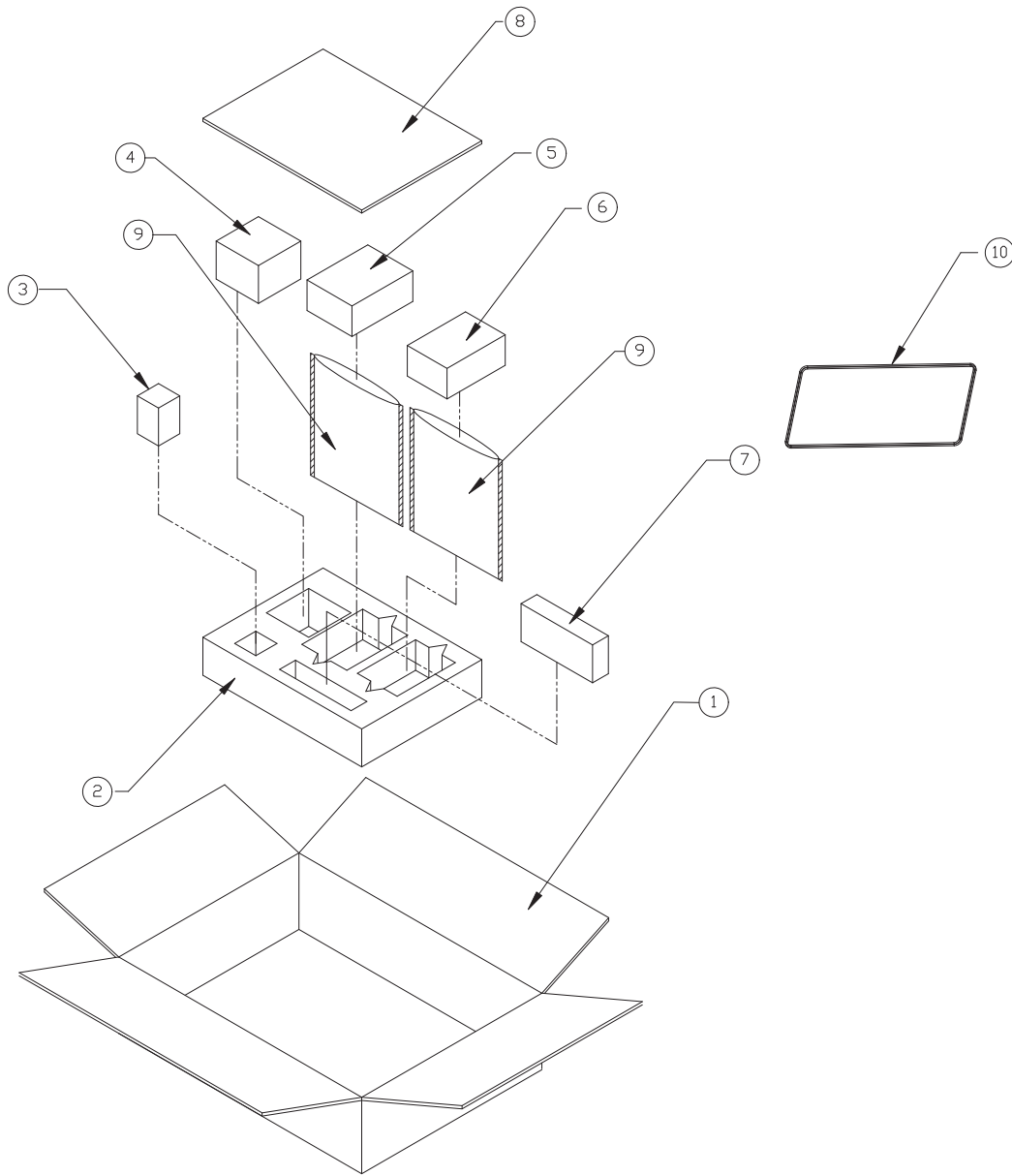

ITEM	PART NO.	QTY.	DESCRIPTION
1	0G7127	1	CARDBOARD BOX
2	0G7128	1	PE-FOAM
3	0G7161	3	BATTERY, AAA
4	0G4904	1	AC ADAPTOR, 120Vac / 5Vdc
5	0G6020	1	HOME SIDE RF ANNUNCIATOR
6	0G6019	1	GENERATOR SIDE RF ANNUNCIATOR
7	0G8856	1	HARN PCB-RF MOD
8	0G8898	1	MANUAL WIRELESS DSP SYS 2008
9	0G7130	2	STATIC SHIELDING BAG 200 X 140 X 0.08t
10	0G7092	1	GASKET 2.0 X 4.0 X 313
11	084543A	2	SCREW PPPH 3 X 12MM
12	052777	2	WASHER FLAT M3

GENERAC POWER SYSTEMS “180 DAY” LIMITED WARRANTY FOR WIRELESS REMOTE MONITOR (FOR AIR-COOLED GENERATORS)

For a period of 180 days from the date of original sale, Generac Power Systems, Inc. (Generac) warrants its wireless remote monitor will be free from defects in materials and workmanship for the items and period set forth below. Generac will, at its option, repair or replace any part which, upon examination, inspection and testing by Generac or a Generac Authorized Warranty Service Dealer, is found to be defective. Any equipment that the purchaser/owner claims to be defective must be returned to and examined by the nearest Generac Authorized Warranty Service Dealer. All transportation costs under the warranty, including return to the factory, are to be borne and prepaid by the purchaser/owner. This warranty applies only to Generac wireless remote monitor and is not transferable from original purchaser.

WARRANTY SCHEDULE

Consumer applications are warranted for 180 days.

CONSUMER APPLICATION

180 DAY - 100% (one hundred percent) coverage on Labor and Part(s) listed (proof of purchase is required):

The warranty period begins on the date of purchase by the first retail end user, and continues for the period of time stated above. “Consumer Application” means personal residential household use by a retail consumer. No other use is warranted.

SAVE YOUR PROOF OF PURCHASE RECEIPT. IF YOU DO NOT PROVIDE PROOF OF THE INITIAL PURCHASE DATE AT THE TIME WARRANTY SERVICE IS REQUESTED, THE MANUFACTURING DATE OF THE PRODUCT WILL BE USED TO DETERMINE THE WARRANTY PERIOD.

All warranty expense allowances are subject to the conditions defined in Generac’s Warranty Policies, Procedures and Flat Rate Manual.

THIS WARRANTY SHALL NOT APPLY TO THE FOLLOWING:

- Costs of normal maintenance, adjustments and cleaning.
- Normal wear and tear.
- Repairs or diagnostics performed by individuals other than Guardian/Generac authorized dealers not authorized in writing by Generac Power Systems.
- Failures due, but not limited, to normal wear and tear, accident, misuse, abuse, negligence or improper use.
- Failures caused by any act of God and other force majeure events beyond the manufactures control.
- Damage related to rodent and/or insect infestation.
- Products that are modified or altered in a manner not authorized by Generac in writing.
- Any incidental, consequential or indirect damages caused by defects in materials or workmanship, or any delay in repair or replacement of the defective part(s).
- Failure due to misapplication.
- Telephone, cellular phone, facsimile, internet access or other communication expenses.
- Living or travel expenses of person(s) performing service, except as specifically included within the terms of a specific unit warranty period.
- Expenses related to “customer instruction” or troubleshooting where no manufacturing defect is found.
- Overnight freight costs for replacement part(s).
- Overtime, holiday or emergency labor.
- Operating batteries, seals, connectors, fuses, mounting hardware and/or equipment.

THIS WARRANTY IS IN PLACE OF ALL OTHER WARRANTIES, EXPRESSED OR IMPLIED. SPECIFICALLY, GENERAC MAKES NO OTHER WARRANTIES AS TO THE MERCHANTABILITY OR FITNESS FOR A PARTICULAR PURPOSE. Any implied warranties which are allowed by law, shall be limited in duration to the terms of the express warranty provided herein. Some states do not allow limitations on how long an implied warranty lasts, so the above limitation may not apply to you. GENERAC’S ONLY LIABILITY SHALL BE THE REPAIR OR REPLACEMENT OF PART(S) AS STATED ABOVE. IN NO EVENT SHALL GENERAC BE LIABLE FOR ANY INCIDENTAL OR CONSEQUENTIAL DAMAGES, EVEN IF SUCH DAMAGES ARE A DIRECT RESULT OF GENERAC’S NEGLIGENCE.

Some states do not allow the exclusion or limitation of incidental or consequential damages, so the above limitation may not apply to you. This warranty gives you specific legal rights. You also have other rights from state to state.

GENERAC POWER SYSTEMS, INC.

P.O. BOX 8 • Waukesha, WI 53187

Ph: (888) GENERAC (436-3722) • Fax: (262) 544-4851

To locate the nearest Authorized Dealer visit our website at www.generac.com