

TEST REPORT

Issued: September 26, 2018

Name and Address of the Customer: MIWA LOCK CO., LTD.
3-1-12 SHIBA, MINATOKU, TOKYO 105-8510, JAPAN

Test Item: DESKTOP CARD READER

Identification: DWMS-VDCR01

Serial No.: T18C01

FCC ID: VBU-DWMSVDCR02

ISED Certification Number: 21683-DWMSVDCR02

Sample No.: 1

Sample Condition: Good

Sample Receipt Date: May 2, 2018

Test Specification: 47 CFR Part 15 Subpart C
RSS-Gen Issue 5, RSS-210 Issue 9

Period of Testing: June 5, 2018 - June 8, 2018

Test Result: PASS

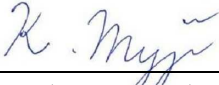
Representative Test Personnel: 
K. Miyaji (EMC Section)
iNARTE : EMC-003627-NE
(2018-09-26)

Reviewed by: 
H. Onishi (EMC Section)
iNARTE : EMC-003318-NT
(2018-09-26)

Other Aspects:

Abbreviations: PASS = passed
FAIL = failed
N/A = not applicable

Note:

This Test Report should not be reproduced except in full, without the written approval of Cosmos Corporation.
The test result of this Test Report is based on the tests made for sample provided, and it is not applicable to individual product identical to the sample or similar product.
The judgment of this test report validates the test item only specified in "4. Summary of Test Results".
This test report is not things that be accredited by VLAC regarding the products and also ensured.
Therefore, this report must not be used for advocating them.

Contents

Page

1. Description of the Tested Sample.....	3
1.1 Product Description	3
1.2 Antenna Description.....	3
1.3 EUT Description	3
2. General Information.....	4
2.1 Test Methodology	4
2.2 Test Facility	4
2.3 Traceability	4
3. Summary of Test Results.....	5
4. Test Condition	6
4.1 Mode of Operation	6
4.2 Additional Equipment	6
4.3 Configuration	7
4.4 EUT Angle.....	9
5. Test Result.....	10
5.1 AC Power Line Conducted Emission (15.207, RSS-Gen 8.8)	10
5.2 Transmitter Spurious Emission (Radiated) (15.209, RSS-Gen 8.9)	13
5.3 20 dB Bandwidth (15.215(c))	16
5.4 Field Strength of Fundamental Emission (15.225(a) (b) (c) (d), RSS-210 B.6)	18
5.5 Frequency Stability (15.225(e), RSS-210 B.6)	22
5.6 Occupied Bandwidth (RSS-Gen Annex A)	25
6. List of Test and Measurement Instruments	26
7. Appendix	29

1. Description of the Tested Sample

1.1 Product Description

Product	DESKTOP CARD READER
Model (referred to as the EUT)	DWMS-VDCR01
Manufacturer	MIWA LOCK CO., LTD.
Hardware Version	DWMS-VDCR01
Software Version	Ver.1.0.0.1
Type of the Equipment	<input checked="" type="checkbox"/> Stand-alone <input type="checkbox"/> Combined Equipment <input type="checkbox"/> Plug-in Radio Device <input type="checkbox"/> Other ()
Transmitter Type	<input type="checkbox"/> ZigBee <input checked="" type="checkbox"/> RFID (Mifare) <input type="checkbox"/> Other ()
Antenna Type	<input checked="" type="checkbox"/> Integral Antenna <input type="checkbox"/> Dedicated External Antenna
Operating Frequency	13.56 MHz
Type of Modulation	ASK
Emission Designator	5M12K1D
Type of Power Source	<input type="checkbox"/> AC Mains <input checked="" type="checkbox"/> Dedicated AC Adaptor <input type="checkbox"/> DC Voltage <input type="checkbox"/> Battery
Input Power Rating	DC 5 V
Type of Battery (if applicable)	N/A
Thermal Limitation	0°C to 40°C

1.2 Antenna Description

Model	Gain	Antenna Type
M2AVPa-C11-200	-49.6 dBi	Loop Antenna

1.3 EUT Description

Equipment under test is as follow:

Equipment	Model	Serial No.
DESKTOP CARD READER	DWMS-VDCR01	T18C01

2. General Information

2.1 Test Methodology

All measurement subject to the present test report is carried out according to the procedures in ANSI C63.10-2013.

2.2 Test Facility

The measurement was carried out at the following facility.

Cosmos Corporation EMC Lab. Oonoki
3571-2 Oonoki, Watarai-cho, Watarai-gun, Mie-ken 516-2102, Japan

- Semi anechoic Chamber 3 m (COAC3M-01)
- Shielded Room (COSR-01)
- Measurement Room

Cosmos Corporation EMC Lab. Oonoki is accredited in accordance with the International Standard ISO/IEC 17025 by the following accreditation bodies and the test facility is registered by the following bodies.

Accreditation: VLAC Accredited Laboratory No. VLAC-039-2
FCC Designation No. JP5182

Registration: ISED Canada Registration No. 3958B

2.3 Traceability

The calibration of measurement equipment used in the test subject to the present report is designed and operated to ensure that the measurement is traceable to national standards of measurement or equivalent abroad.

3. Summary of Test Results

These test results are the test results of the condition specified with “4. Test Condition”.

FCC Section	IC Section	Test Item	FCC Result	IC Result
15.207	RSS-Gen 8.8	AC Power Line Conducted Emission	PASS	PASS
15.209, 15.225(d)	RSS-Gen 8.9	Transmitter Spurious Emission (Radiated)	PASS	PASS
15.215(c)	---	20 dB Bandwidth	PASS	---
15.225 (a) (b) (c)	RSS-210 B.6	Field Strength of Fundamental Emission	PASS	PASS
15.225(e)	RSS-210 B.6	Frequency Stability	PASS	PASS
---	RSS-Gen 7.1	Receiver Spurious Emission (Radiated)	---	N/A*
---	RSS-Gen Annex A	Occupied Bandwidth	---	PASS

Note:

*: This item does not apply because this device receives some data only while the radio waves are transmitted.

4. Test Condition

4.1 Mode of Operation

Mode of operation : RFID

Note:

The EUT makes communication emission with the maximum RF power by a special test program.

The test of Field Strength of Fundamental Emission was performed under the following condition:

Voltage: AC 120 V \pm 15%

The test of Frequency Stability was performed under the following condition:

Temperature: -20°C to +50°C

Voltage: AC 120 V \pm 15%

4.2 Additional Equipment

The equipment was tested together with additional peripherals.



The following peripherals were used during the tests:

Equipment	Model	Serial No.	Manufacturer
AC Adapter	ATS018T-W050V	E180502	ADAPTER TECH.
Personal Computer	PP17L	CN-0N8719-48643- 57F-1500	DELL
AC Adapter	HP-OQ065B83	CN-0N2765-47890- 47D-8266	DELL
USB Mouse	M-UAE96	LZ916AC0085	Logicool

4.3 Configuration

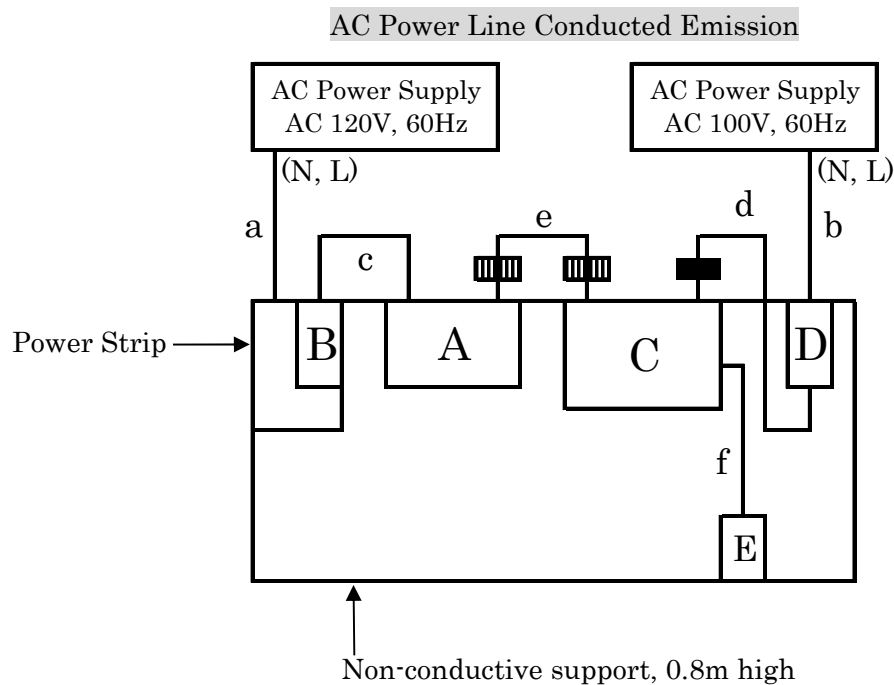
	Equipment	Model	Cable	Length	Shield	
A	DESKTOP CARD READER	DWMS-VDCR01	a	AC Power Cord	1.0 m	×
			b	AC Power Cord	1.2 m	×
B	AC Adapter	ATS018T-W050V	c	DC Power Cord	1.5 m	×
C	Personal Computer	PP17L	d	DC Power Cord	1.9 m	×
D	AC Adapter	HP-OQ065B83	e	RS 232C Cable	1.9 m	○
E	USB Mouse	M-UAE96	f	USB Mouse Cable	1.8 m	○



-  Ferrite Core: 2 turns (E04SR241336A, SEIWA ELECTRIC MFG.)
-  Integrated Ferrite Core

4.3 Configuration (Continued)

Transmitter Spurious Emission (Radiated)
Field Strength of Fundamental Emission (normal voltage)

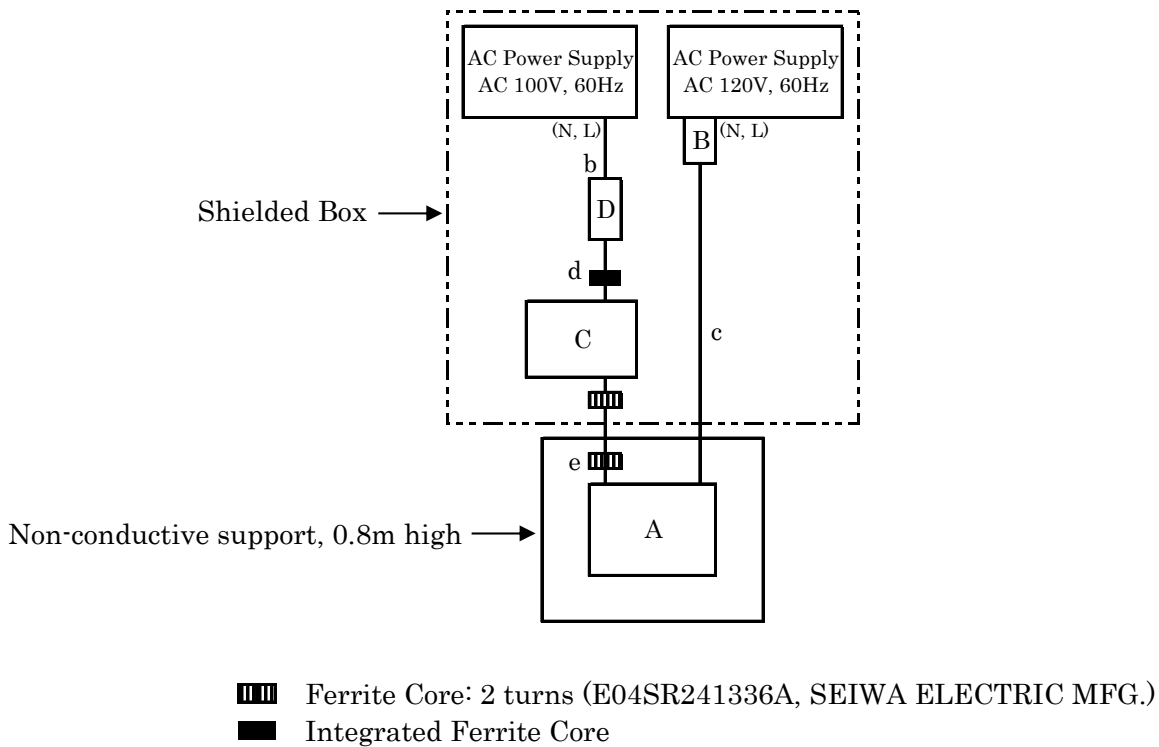

Field Strength of Fundamental Emission (normal and ±15% voltage)
20 dB Bandwidth / Frequency Stability / Occupied Bandwidth

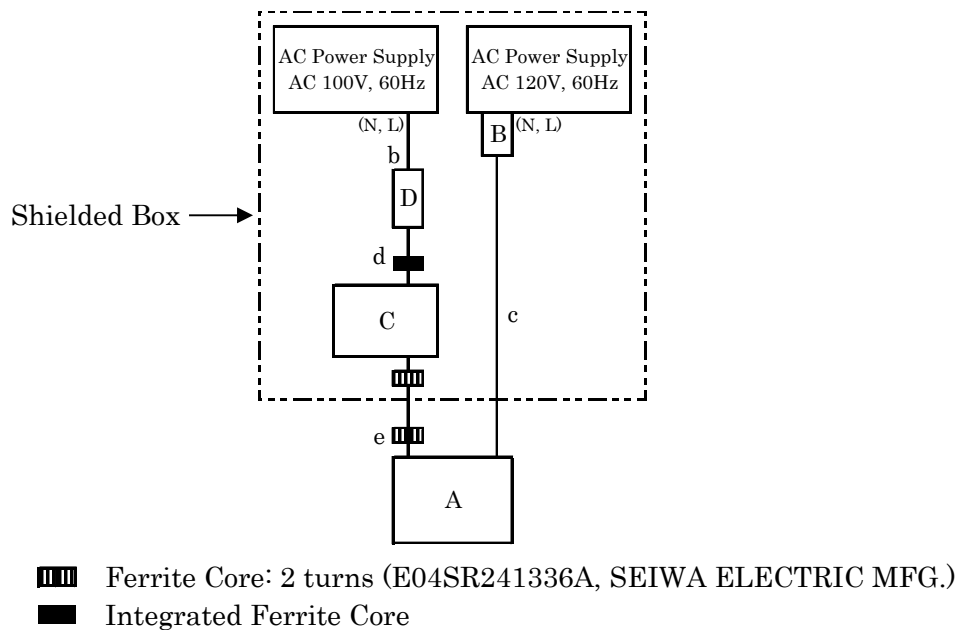

4.4 EUT Angle

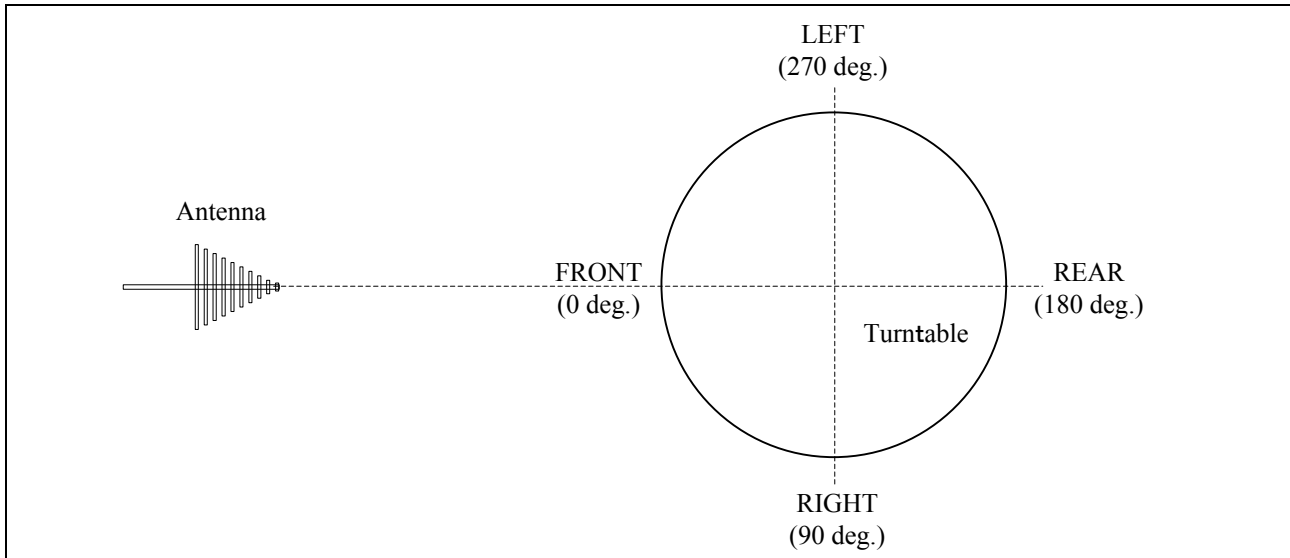

5. Test Result

5.1 AC Power Line Conducted Emission (15.207, RSS-Gen 8.8)

5.1.1 Setting Remarks

The conducted disturbance voltage of AC power line in the frequency range from 150 kHz to 30 MHz was measured in accordance with ANSI C63.10-2013.

The non-conductive table, 0.8 m high, was placed on the reference ground plane, and the EUT was put on the non-conductive table. The used Line Impedance Stabilizing Network (LISN) has a rated impedance of 50 Ω /50 μ H as specified in CISPR16-1-2. The test receiver with Quasi Peak and Average detector is in accordance with CISPR 16-1-1. The conducted emission level is calculated by adding Cable Attenuation Factor and Insertion Loss of LISN.

Setting Condition of Test receiver

Frequency range	Detector	RBW
150 kHz to 30 MHz	Quasi Peak	9 kHz
	Average	9 kHz

5.1.2 Limit

Frequency range	Conducted Limit [dB μ V]	
	Quasi Peak	Average
150 kHz to 500 kHz	66 to 56 *	56 to 46 *
500 kHz to 5 MHz	56	46
5 MHz to 30 MHz	60	50

Note:

*: Decrease with the logarithm of the frequency.

5.1.3 Test Detail

Result: PASS

Uncertainty of measurement result : ± 1.98 dB
Engineer : M. Okada
Date of testing : June 6, 2018
Room temperature : 23°C
Relative humidity : 62%

Sample Calculation

Result = Reading + c.f
= $36.2 + 10.3$
= 46.5

Margin = Limit – Result
= $65.1 - 46.5$
= 18.6

Note:

c.f (Correction Factor) = Cable Attenuation Factor + LISN Factor

5.1.3 Test Detail (Continued)

Test Data

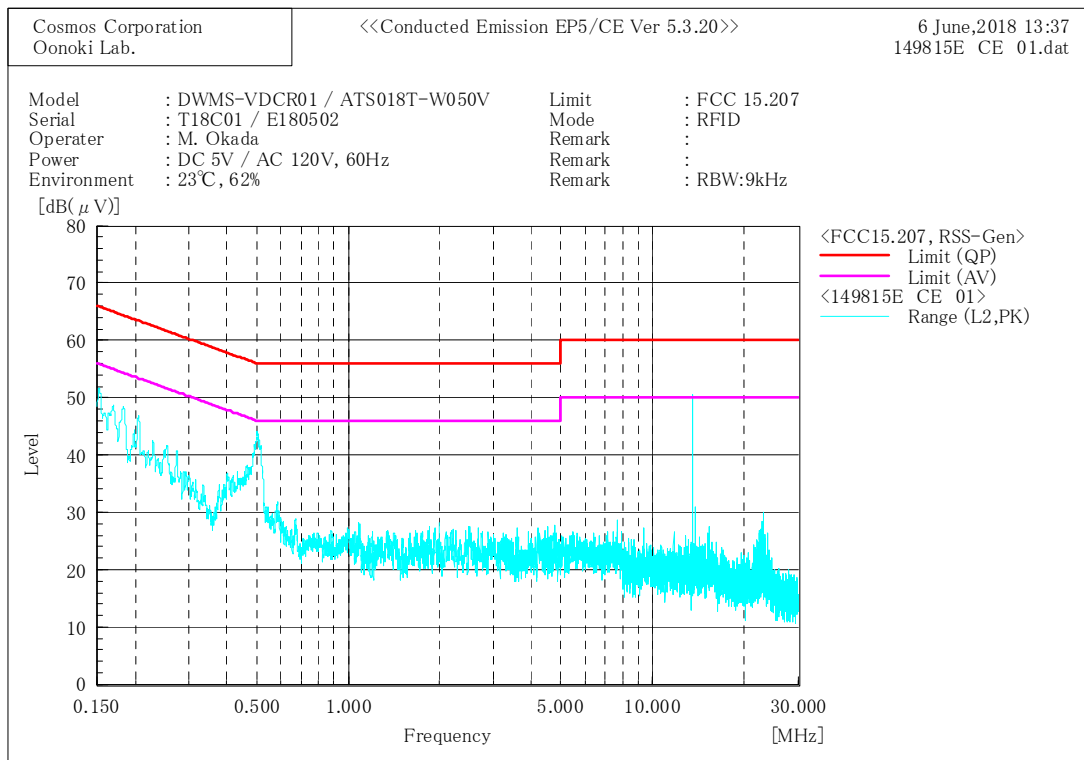
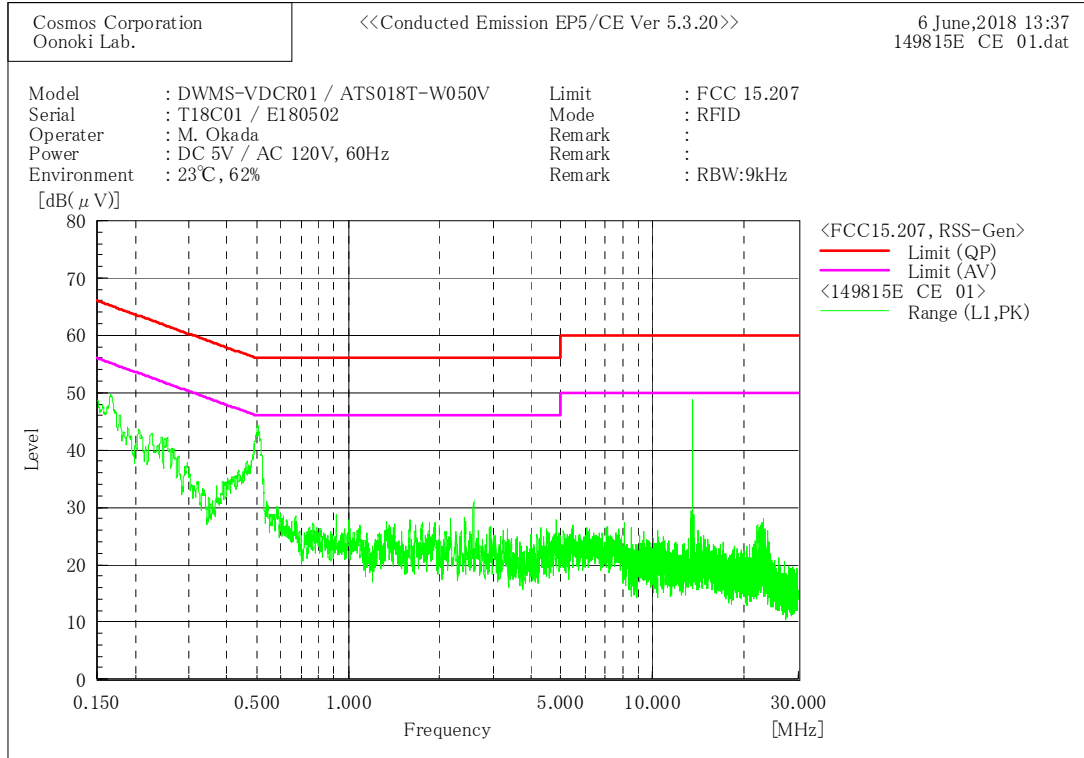

5.2 Transmitter Spurious Emission (Radiated) (15.209, RSS-Gen 8.9)

5.2.1 Setting Remarks

The electric field strength was measured in accordance with ANSI C63.10-2013, in the frequency range from 9 kHz to 1 GHz (over 10th harmonics) except for the frequency band on which the transmitter is intended to operate.

The test setup was made on the turntable installed in a semi-anechoic chamber.

The non-conductive table, 0.8 m high, was placed on the turntable, and the EUT was put on the non-conductive table. The EUT was measured at 1 m to 4 m height of the antenna above 30 MHz. The turntable was fully rotated. The highest radiation from the equipment was recorded. The measurement above 30 MHz was carried out with both horizontal and vertical antenna polarization. The test receiver with Peak, Quasi Peak and Average detector is in accordance with CISPR 16-1-1.

The measurement was carried out with the measuring distance of 3 m.

Setting Condition of Test receiver

Frequency range	Detector	RBW
9 kHz to 90 kHz	Peak	200 Hz
	Average	200 Hz
90 kHz to 110 kHz	Quasi Peak	200 Hz
110 kHz to 150 kHz	Peak	200 Hz
	Average	200 Hz
150 kHz to 490 kHz	Peak	9 kHz
	Average	9 kHz
490 kHz to 30 MHz	Quasi Peak	9 kHz
30 MHz to 1 GHz	Quasi Peak	120 kHz

5.2.2 Limit

The emission limits shown in the following table are based on measurements employing a CISPR Quasi Peak detector except for the frequency bands 9 kHz to 90 kHz, 110 kHz to 490 kHz and above 1000 MHz. Radiated emission limits in these three bands are based on measurements employing an Average detector. The limit on Peak radio frequency emissions is 20 dB above the maximum permitted Average emission limit applicable to the equipment under test.

Frequency range	Field Strength (Distance)			
	[$\mu\text{V/m}$]		[dB $\mu\text{V/m}$]	
9 kHz to 490 kHz	2400/F (kHz) 266.6 to 4.89	(300 m)	128.5 to 93.8	(3 m)
490 kHz to 1.705 MHz	24000/F (kHz) 48.9 to 14.0	(30 m)	73.8 to 62.9	(3 m)
1.705 MHz to 30 MHz	30	(30 m)	69.5	(3 m)
30 MHz to 88 MHz	100	(3 m)	40.0	(3 m)
88 MHz to 216 MHz	150	(3 m)	43.5	(3 m)
216 MHz to 960 MHz	200	(3 m)	46.0	(3 m)
Above 960 MHz	500	(3 m)	53.9	(3 m)

5.2.3 Test Detail

Result: PASS

Uncertainty of measurement result : ± 4.06 dB
 Engineer : M. Okada
 Date of testing : June 7, 2018
 Room temperature : 21 – 22°C
 Relative humidity : 66 – 68%

<Below 30 MHz>

No spurious emission for RF module was found in 9 kHz to 30 MHz.

5.2.3 Test Detail (Continued)

Sample Calculation

$$\begin{aligned} \text{Result} &= \text{Reading} + \text{c.f} \\ &= 41.7 + (-11.2) \\ &= 30.5 \end{aligned}$$

$$\begin{aligned} \text{Margin} &= \text{Limit} - \text{Result} \\ &= 43.5 - 30.5 \\ &= 13.0 \end{aligned}$$

Note:

c.f (Correction Factor) = Cable Attenuation Factor + Antenna Factor + Amplifier Gain

<Above 30 MHz> Test Data

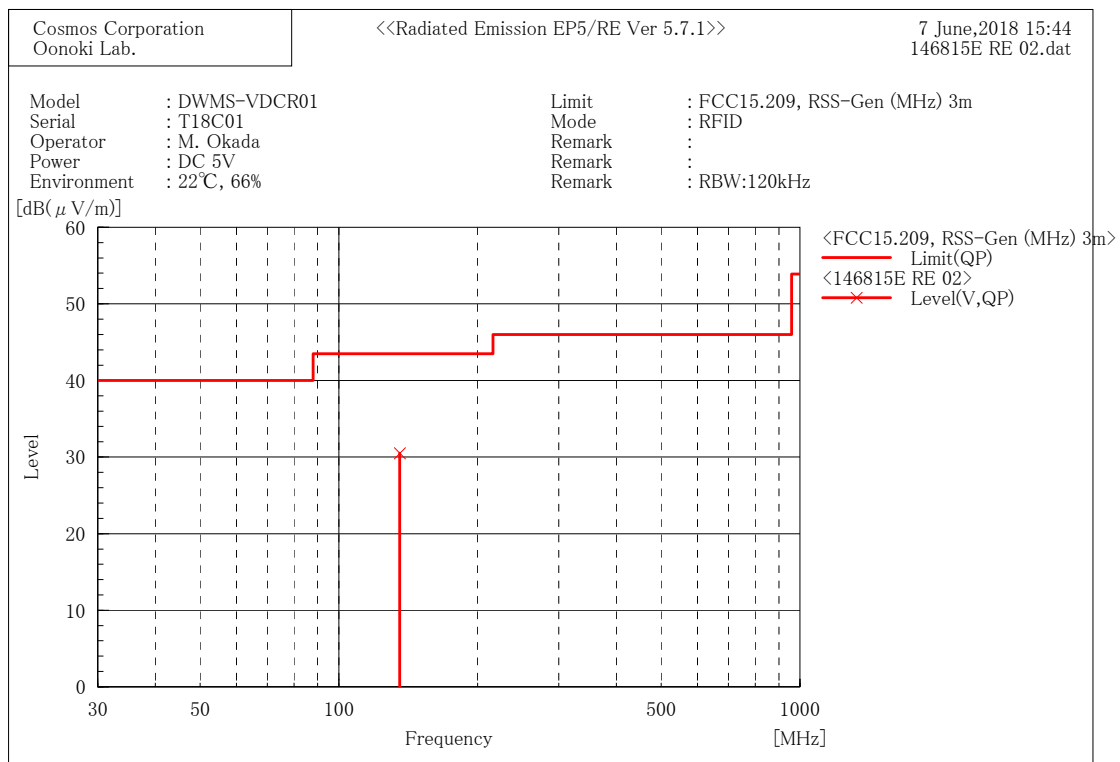

Final Result

--- Vertical Polarization (QP)---

No.	Frequency [MHz]	Reading [dB(μV)]	c.f [dB(1/m)]	Result [dB(μV/m)]	Limit [dB(μV/m)]	Margin [dB]	Height [cm]	Angle [°]
1	135.600	41.7	-11.2	30.5	43.5	13.0	100.0	235.0

5.3 20 dB Bandwidth (15.215(c))

5.3.1 Setting Remarks

The both side of 20 dB down value from peak power were measured by using the spectrum analyzer.

The spectrum analyzer is set as following:

- Resolution Bandwidth : 1% to 5% of the OBW (not less than 1 kHz)
- Video Bandwidth : Approx. $3 \times$ RBW or greater
- Detector Mode : Peak
- Trace Mode : Max Hold

5.3.2 Limit

Intentional radiators must be designed to ensure that the 20 dB bandwidth of the emission is contained within the frequency band designated in the rule section under which the equipment is operated

5.3.3 Test Detail

Result: PASS

- Uncertainty of measurement result : $\pm 0.013\%$
- Engineer : K. Miyaji
- Date of testing : June 5, 2018
- Room temperature : 24°C
- Relative humidity : 53%

Test Data

	Edge of Bandwidth [MHz]	Limit [MHz]	Margin [kHz]
Lower	13.345	13.11	235
Higher	13.776	14.01	234

5.3.3 Test Detail (Continued)

Test Data

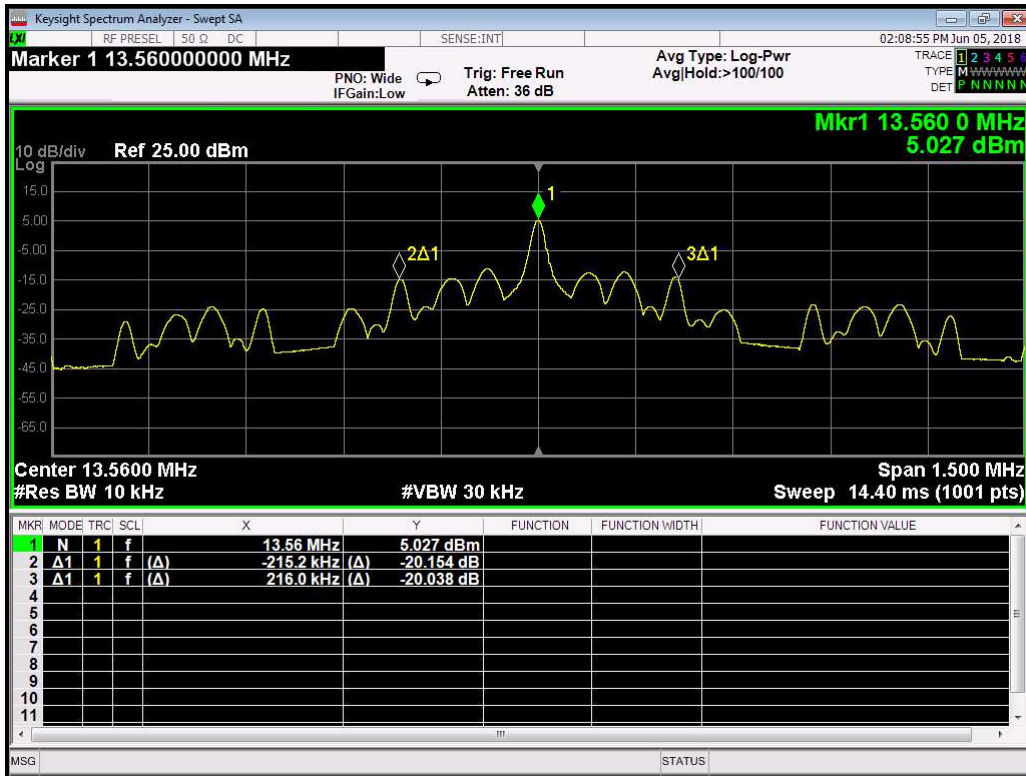

5.4 Field Strength of Fundamental Emission (15.225(a) (b) (c) (d), RSS-210 B.6)

5.4.1 Setting Remarks

The test setup was made in accordance with ANSI C63.10:2013 in a semi-anechoic chamber. The non-conductive table, 0.8 m high, was placed on the turntable, and the EUT was put on the non-conductive table. The turntable was fully rotated. The highest radiation from the equipment was recorded. The measurement was carried out with the measuring distance of 3 m. The test receiver with Quasi Peak detector is in accordance with CISPR 16-1-1. Then the limit of 30 m distance was converted to the limit of 3 m distance with the $40\log(30\text{ m}/3\text{ m})$.

5.4.2 Limit

Frequency range	Field Strength (Distance)	
	[$\mu\text{V}/\text{m}$]	[dB $\mu\text{V}/\text{m}$]
13.553 MHz to 13.567 MHz	15848 (30 m)	123.9 (3 m)
13.410 MHz to 13.553 MHz and 13.567 MHz to 13.710 MHz	334 (30 m)	90.4 (3 m)
13.110 MHz to 13.410 MHz and 13.710 MHz to 14.010 MHz	106 (30 m)	80.5 (3 m)
Outside of 13.110 MHz to 14.010 MHz	30 (30 m)	69.5 (3 m)

5.4.3 Test Detail

Result: PASS

Uncertainty of measurement result : ± 2.01 dB
 Engineer : M. Okada
 Date of testing : June 6, 2018
 Room temperature : 23°C
 Relative humidity : 64%

5.4.3 Test Detail (Continued)

Sample Calculation

$$\begin{aligned} \text{Result} &= \text{Reading} + \text{c.f} \\ &= 4.7 + 22.1 \\ &= 26.8 \end{aligned}$$

$$\begin{aligned} \text{Margin} &= \text{Limit} - \text{Result} \\ &= 69.5 - 26.8 \\ &= 42.7 \end{aligned}$$

Note:

c.f (Correction Factor) = Cable Attenuation Factor + Antenna Factor

Test Data (120 V)

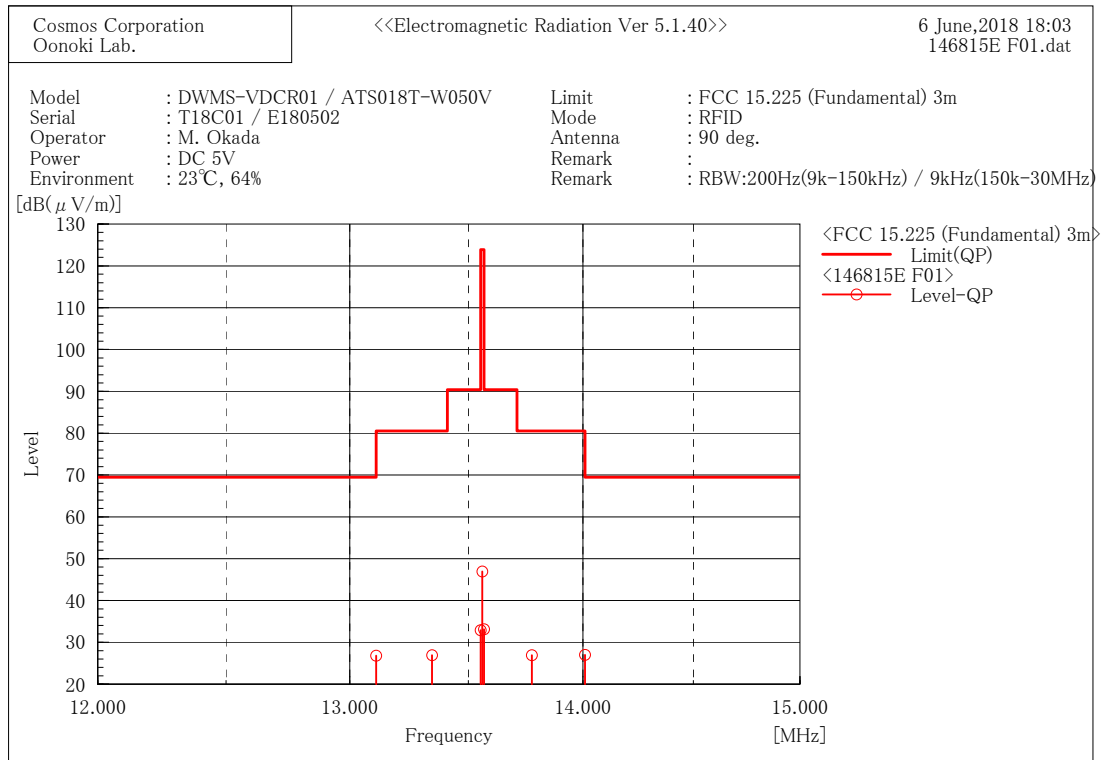

Final Result

No.	Frequency [MHz]	Reading [dB(μV)]	c. f [dB(1/m)]	Result [dB(μV/m)]	Limit [dB(μV/m)]	Margin [dB]
1	13.110	4.7	22.1	26.8	69.5	42.7
2	13.345	4.8	22.1	26.9	80.5	53.6
3	13.553	10.7	22.2	32.9	90.4	57.5
4	13.560	24.7	22.2	46.9	123.9	77.0
5	13.567	10.9	22.2	33.1	90.4	57.3
6	13.775	4.7	22.2	26.9	80.5	53.6
7	14.010	4.7	22.3	27.0	69.5	42.5

5.4.3 Test Detail (Continued)

Test Data (102 V)

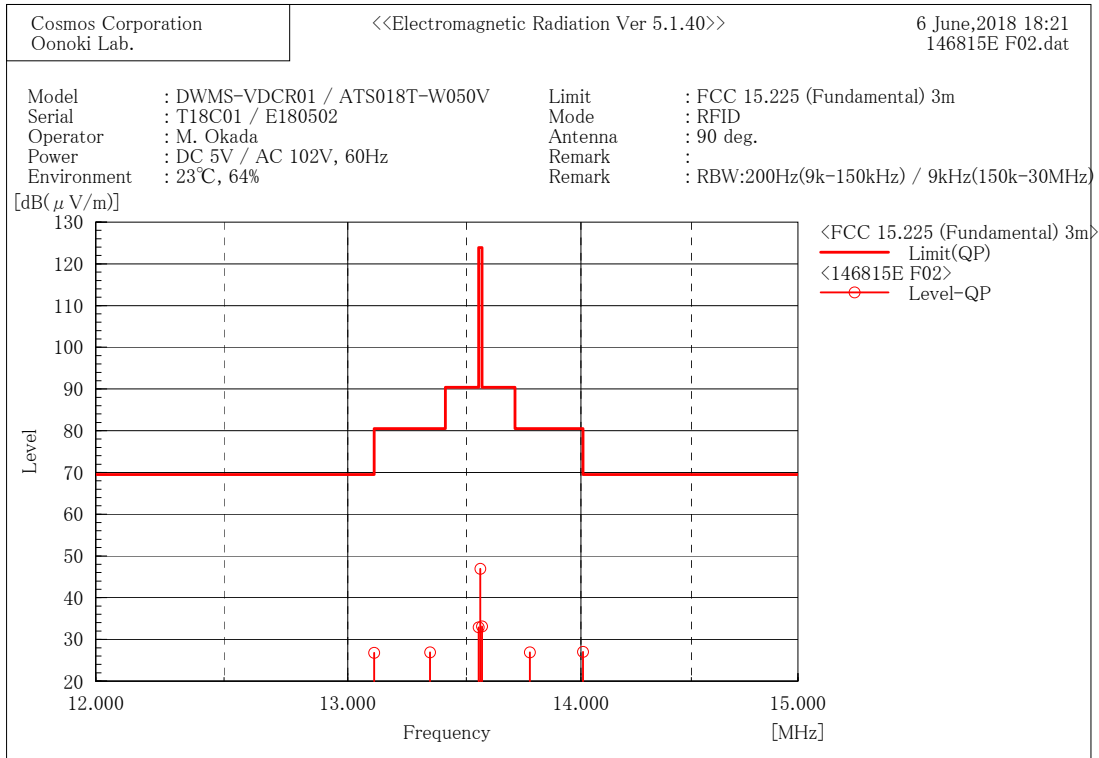

Final Result

No.	Frequency [MHz]	Reading [dB(μV)]	c. f [dB(1/m)]	Result [dB(μV/m)]	Limit [dB(μV/m)]	Margin [dB]
1	13.110	4.7	22.1	26.8	69.5	42.7
2	13.345	4.8	22.1	26.9	80.5	53.6
3	13.553	10.7	22.2	32.9	90.4	57.5
4	13.560	24.7	22.2	46.9	123.9	77.0
5	13.567	10.9	22.2	33.1	90.4	57.3
6	13.775	4.7	22.2	26.9	80.5	53.6
7	14.010	4.7	22.3	27.0	69.5	42.5

5.4.3 Test Detail (Continued)

Test Data (138 V)

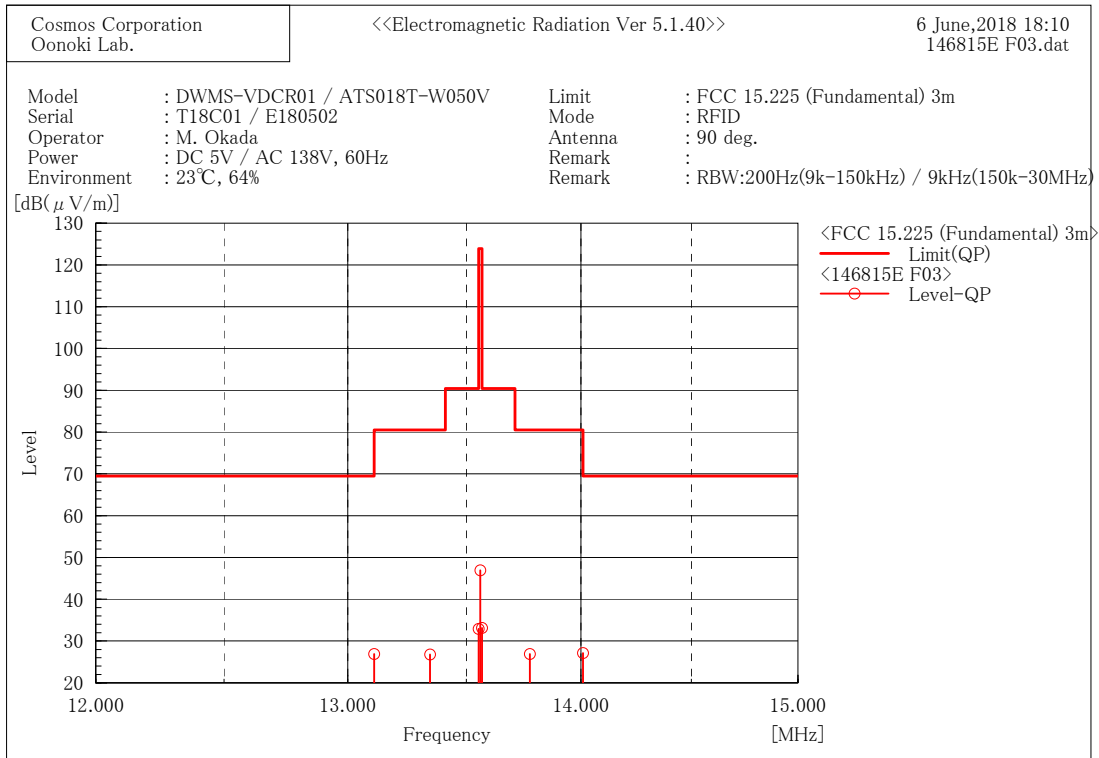

Final Result

No.	Frequency [MHz]	Reading [dB(μV)]	c. f [dB(1/m)]	Result [dB(μV/m)]	Limit [dB(μV/m)]	Margin [dB]
1	13.110	4.8	22.1	26.9	69.5	42.6
2	13.345	4.7	22.1	26.8	80.5	53.7
3	13.553	10.7	22.2	32.9	90.4	57.5
4	13.560	24.7	22.2	46.9	123.9	77.0
5	13.567	10.9	22.2	33.1	90.4	57.3
6	13.775	4.7	22.2	26.9	80.5	53.6
7	14.010	4.8	22.3	27.1	69.5	42.4

5.5 Frequency Stability (15.225(e), RSS-210 B.6)

5.5.1 Setting Remarks

The EUT was placed in an environmental test chamber, exposed in extreme temperatures until its temperature is stabilized. The measurement was carried out at every 10°C from -20°C to +50°C in the most common nominal supply voltage and the measurement was carried out at ±15% of rated voltage at 20°C.

5.5.2 Limit

The frequency stability of the carrier signal shall be maintained within ±0.01% of the operating frequency.

5.5.3 Test Detail

Result: PASS

Uncertainty of measurement result : ±0.10 Hz
 Engineer : M. Okada
 Date of testing : June 8, 2018
 Room temperature : Refer to Test Data

Sample Calculation

Deviation [Hz] = Measured Frequency – Center Frequency
 = 13559992.8 – 13560000
 = -7.2

Deviation [ppm] = |Deviation [Hz]| ÷ Center Frequency × 1000000
 = |-7.2| ÷ 13560000 × 1000000
 ÷ 0.5

Margin = Limit – Deviation [ppm]
 = 100 – 0.5
 = 99.5

5.5.3 Test Detail (Continued)

Test Data

Temp [°C]	Operation Time	Measured Frequency [Hz]	Deviation [Hz]	Deviation [ppm]	Limit [ppm]	Margin [ppm]
50	Startup	13559992.8	-7.2	0.5	100	99.5
	2 min	13559990.1	-9.9	0.7	100	99.3
	5 min	13559989.4	-10.6	0.8	100	99.2
	10 min	13559988.5	-11.5	0.8	100	99.2
40	Startup	13560020.0	20.0	1.5	100	98.5
	2 min	13560014.9	14.9	1.1	100	98.9
	5 min	13560007.2	7.2	0.5	100	99.5
	10 min	13560002.9	2.9	0.2	100	99.8
30	Startup	13560049.8	49.8	3.7	100	96.3
	2 min	13560040.3	40.3	3.0	100	97.0
	5 min	13560034.1	34.1	2.5	100	97.5
	10 min	13560025.6	25.6	1.9	100	98.1
20	Startup	13560065.5	65.5	4.8	100	95.2
	2 min	13560059.2	59.2	4.4	100	95.6
	5 min	13560056.2	56.2	4.1	100	95.9
	10 min	13560053.6	53.6	4.0	100	96.0
10	Startup	13560083.7	83.7	6.2	100	93.8
	2 min	13560079.3	79.3	5.8	100	94.2
	5 min	13560078.6	78.6	5.8	100	94.2
	10 min	13560078.3	78.3	5.8	100	94.2
0	Startup	13560100.7	100.7	7.4	100	92.6
	2 min	13560100.2	100.2	7.4	100	92.6
	5 min	13560099.7	99.7	7.4	100	92.6
	10 min	13560098.9	98.9	7.3	100	92.7
-10	Startup	13560090.5	90.5	6.7	100	93.3
	2 min	13560095.2	95.2	7.0	100	93.0
	5 min	13560096.9	96.9	7.1	100	92.9
	10 min	13560098.1	98.1	7.2	100	92.8
-20	Startup	13560054.3	54.3	4.0	100	96.0
	2 min	13560064.7	64.7	4.8	100	95.2
	5 min	13560069.3	69.3	5.1	100	94.9
	10 min	13560073.1	73.1	5.4	100	94.6

5.5.3 Test Detail (Continued)

Test Data

Temp [°C]	Supply Voltage [V]	Measured Frequency [Hz]	Deviation [Hz]	Deviation [ppm]	Limit [ppm]	Margin [ppm]
20	102.00	13560052.6	52.6	3.9	100	96.1
	120.00	13560053.6	53.6	4.0	100	96.0
	138.00	13560051.9	51.9	3.8	100	96.2

Test Data

Temp [°C]	Supply Voltage [V]	Measured Frequency [Hz]	Deviation [Hz]	Deviation [ppm]	Limit [ppm]	Margin [ppm]
50	120	13559988.5	-65.1	4.8	100	95.2
20	120	13560053.6	reference value			
-20	120	13560073.1	19.5	1.4	100	98.6
20	102	13560052.6	-1.0	0.1	100	99.9
	138	13560051.9	-1.7	0.1	100	99.9

5.6 Occupied Bandwidth (RSS-Gen Annex A)

5.6.1 Setting Remarks

Occupied Bandwidth is measured by using 99% Bandwidth measurement function of the spectrum analyzer.

The spectrum analyzer is set as following:

- Resolution Bandwidth : 1% to 5% of the OBW (not less than 1 kHz)
- Video Bandwidth : Approx. $3 \times$ RBW or greater
- Detector Mode : Peak
- Trace Mode : Max Hold

5.6.2 Test Detail

Result: PASS

- Uncertainty of measurement result : $\pm 0.013\%$
- Engineer : K. Miyaji
- Date of testing : June 5, 2018
- Room temperature : 24°C
- Relative humidity : 53%

Test Data

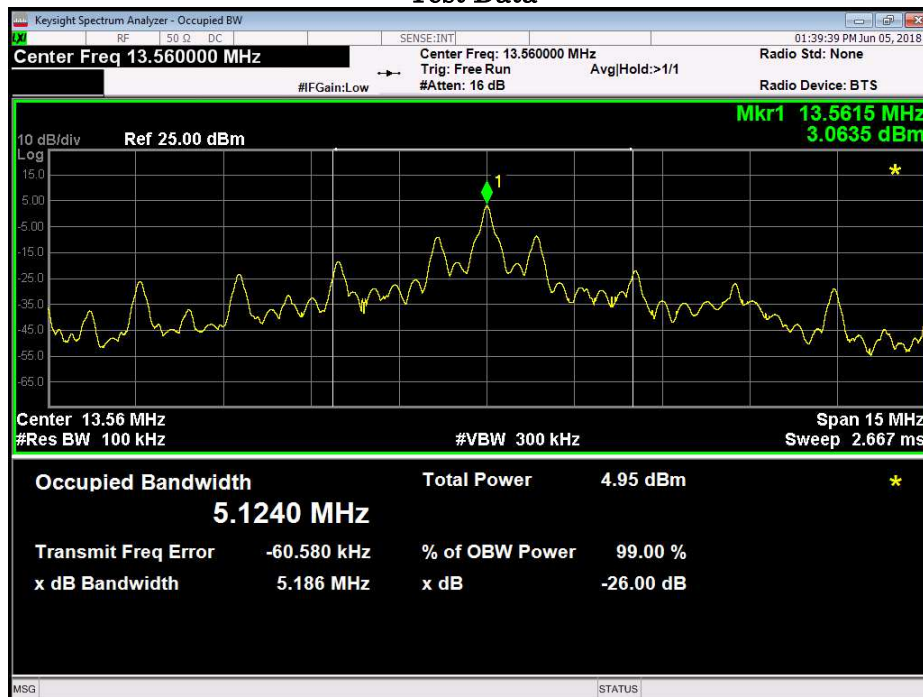

6. List of Test and Measurement Instruments

AC Power Line Conducted Emission

Instruments	Manufacturer	Model	Serial No.	Calibrated Date/Until
EMI Test Receiver	ROHDE & SCHWARZ	ESCI	100413	2018/03/30 2019/03/29
Artificial-Mains Network /Highpass Filter /Attenuator 10 dB	Kyoritsu /Kyoritsu /TAMAGAWA	KNW-341C (F) /KFL-007 /CFA-03	8-1659-1 /8-1708-10 /---	2017/06/09 2018/06/08
Artificial-Mains Network /Highpass Filter /Attenuator 10 dB	Kyoritsu /Kyoritsu /TAMAGAWA	KNW-243C (F) /KFL-007 /CFA-03	8-1238-3 /8-1741-1 /---	2018/05/28 2019/05/27
Shielded Room	JSE	COSR-01	---	---
RF Cable RF Selector (9 kHz to 30 MHz)	Fujikura	3D-2W	OC01	2018/04/18 2019/04/17
	SUHNER	RG223/U	OC02 OC04	
	TSJ	RFM-E221	3148	
50 Ω Terminator	TAAMAGAWA	CT-01	(OE00527)	2017/11/03 2018/11/02
Thermometer Hygrometer	EMPEX	TD-8316	(OE00521)	2017/08/04 2018/08/03
Software	TOYO	EP5/CE (ver 5.3.20)	---	---

6. List of Test and Measurement Instruments (Continued)

Transmitter Spurious Emissions (Radiated) (Below 1 GHz) Field Strength of Fundamental Emission

Instruments	Manufacturer	Model	Serial No.	Calibrated Date/Until
EMI Test Receiver	ROHDE & SCHWARZ	ESCI	100413	2018/03/30 2019/03/29
Loop Antenna (9 kHz to 30 MHz)	SCHAFFNER	HLA6120	1137	2015/11/06 2018/11/05
Anechoic Chamber 3 m	JSE	COAC3M-01	---	2017/09/01 2018/08/31
RF Cable RF Selector (9 kHz to 30 MHz)	Fujikura	5D-2W	OC09	2018/04/18 2019/04/17
	SUHNER	RG223/U	OC10 OC11 OC12	
	TSJ	RFM-E121	03149	
Thermometer Hygrometer	EMPEX	TD-8316	(ME00836S)	2017/10/19 2018/10/18
Software	TOYO	EP5/ME (ver 5.1.40)	---	---

6. List of Test and Measurement Instruments (Continued)

Transmitter Spurious Emission (Radiated) (Above 30 MHz)

Instruments	Manufacturer	Model	Serial No.	Calibrated Date/Until
EMI Test Receiver	ROHDE & SCHWARZ	ESCI	100413	2018/03/30 2019/03/29
Pre-Amplifier (30 MHz to 1 GHz)	HEWLETT PACKARD	8447D OPT 010	2944A 07891	2018/04/13 2019/04/12
Biconical Antenna (30 MHz to 300 MHz)	SCHWARZBECK	VHBB9124 / BBA9106	9124-311	2016/09/05 2019/09/04
Log-Periodic Antenna (300 MHz to 1 GHz)	SCHWARZBECK	UHALP9108-A	0645	2016/09/05 2019/09/04
Anechoic Chamber 3 m	JSE	COAC3M-01	---	2017/09/01 2018/08/31
Attenuator 3 dB	JFW	50FP-003-H2	---	2018/04/11 2019/04/12
RF Cable RF Selector (30 MHz to 1 GHz)	Fujikura	8D-2W	OC14	2018/04/18 2019/04/17
	SUHNER	RG223/U	OC11	
		RG214/U	OC15 OC16	
		RG400/U	OC17	
	TSJ	RFM-E121	03149	
Thermometer Hygrometer	EMPEX	TD-8316	(ME00836S)	2017/10/19 2018/10/18
Software	TOYO	EP5/RE (ver 5.7.1)	---	---

20 dB Bandwidth / Frequency Stability / Occupied Bandwidth

Instruments	Manufacturer	Model	Serial No.	Calibrated Date/Until
EMI Test Receiver	ROHDE & SCHWARZ	ESCI	100413	2018/03/30 2019/03/29
Thermostatic Chamber	ESPEC	PU-2KP	14010409	2017/09/21 2018/09/20
Thermometer	SATO KEIRYOKI MFG	PC-5000TRH- II	10A03	2017/10/19 2018/10/18

7. Appendix

Refer to separated files for the following appendixes.

Appendix 1: Photographs of the Test Setup

Appendix 2: External Photographs

----- End of Report -----