

# TEST REPORT

Report No.: Z071C-07531

Issue Date: March 27, 2008

The device, as described herewith, was tested pursuant to applicable test procedure indicated below and complies with the requirements of;

## FCC Part15 Subpart C

The test results are traceable to the international or national standards.

|                            |   |   |
|----------------------------|---|---|
| Applicant                  | : | MIWA LOCK CO., LTD.<br>3-1-12, SHIBA, MINATO-KU,<br>TOKYO 105-8510, JAPAN<br>Phone: +81-3-3452-1463 Fax.: +81-3-3452-3662 |
| Equipment under test (EUT) | : | ALVH ENTRANCE READER  |
| FCC ID                     | : | VBU-ALVHDCU   |
| Model Number               | : | ALVHDCU·DP  |
| Serial Number              | : | N/A   |
| EUT Condition              | : | Pre-production  |

Test procedure : ANSI C63.4-2003  
Date of test : March 17,26 2008  
April 21, 2008  
Test place : 3m Semi-anechoic chamber, Shielded room, Site 2  
Test results : Complied

Zacta Technology Corporation certifies that no party to the application is subject to a denial of federal benefits that include FCC benefits, pursuant to Section 5301 of the Anti-Drug Abuse Act of 1988,21U.S.C. 853(a).

The results in this report are applicable only to the samples tested.  
This report shall not be re-produced except in full without the written approval of ZACTA Technology Corporation.

This test report must not be used by client to claim product certification, approval, or endorsement by NVLAP, NIST, or any agency of the federal government.

Tested by: Hiro Suzuki  
Hiroaki Suzuki

Authorized by: Jun Shimanuki  
Jun Shimanuki  
General Manager of Technical Division

## ***Table of contents***

---

|  |    |
|--|----|
| 1. Summary of Test.....  | 4  |
| 1.1 Purpose of test.....   | 4  |
| 1.2 Summary of test results .....                                      | 4  |
| 2. Equipment description.....  | 5  |
| 2.1 EUT information.....   | 5  |
| 2.2 Operating flow .....   | 6  |
| 2.2.1 Operating condition.....   | 6  |
| 2.2.2 Test mode.....   | 6  |
| 3. Configuration information.....                                      | 7  |
| 3.1 Peripheral(s) used .....   | 7  |
| 3.2 Cable(s) information.....  | 7  |
| 3.3 System configuration.....  | 7  |
| 4. Test Instruments.....   | 8  |
| 5. Test Type and Results .....   | 9  |
| 5.1 20dB Bandwidth / 99% Occupied Bandwidth.....                       | 9  |
| 5.1.1 Test Procedure [ FCC 15.215 (c), IC RSS-Gen. 4.6.1 ].....        | 9  |
| 5.1.2 Test Instruments and Measurement Setup .....                     | 9  |
| 5.1.3 Limit of Bandwidth at 20dB Bandwidth/99% Occupied Bandwidth..... | 9  |
| 5.1.4 Measurement Result.....  | 10 |
| 5.1.5 Trace Data.....  | 10 |
| 5.2 Operation within the band 13.110-14.010MHz .....                   | 11 |
| 5.2.1 Test Procedure [ FCC 15.209/15.225(a)(b)(c)(d) ].....            | 11 |
| 5.2.2 Test Instruments and Measurement Setup .....                     | 11 |
| 5.2.3 Limit of Operation within the band 13.110-14.010MHz.....         | 11 |
| 5.2.4 Measurement Result.....  | 12 |
| 5.2.5 Trace Data.....  | 13 |
| 5.3 Transmitter Radiated Spurious Emissions (9kHz-1000MHz).....        | 15 |
| 5.3.1 Test Procedure [ FCC 15.209/225(d) ].....                        | 15 |
| 5.3.2 Test Instruments and Measurement Setup .....                     | 15 |
| 5.3.3 Limit of Spurious Emissions Measurement.....                     | 16 |
| 5.3.4 Sample of field strength calculation.....                        | 16 |
| 5.3.5 Measurement Result.....  | 16 |
| 5.4 Frequency Tolerance .....  | 21 |
| 5.4.1 Test Procedure [ FCC 15.225(e) ].....                            | 21 |
| 5.4.2 Test Instruments and Measurement Setup .....                     | 21 |
| 5.4.3 Limit of Frequency Tolerance.....                                | 21 |

|   |    |
|---|----|
| 5.4.4 Measurement Result.....   | 21 |
| 5.5 AC power line Conducted Emissions.....  | 22 |
| 5.5.1 Test Procedure [ FCC 15.207 ].....  | 22 |
| 5.5.2 Test Instruments and Measurement Setup .....                                      | 22 |
| 5.5.3 Test equipment for AC power line Conducted Emissions.....                         | 23 |
| 5.5.4 Limit of AC power line Conducted Emissions Measurement (Sample calculation) ..... | 23 |
| 5.5.5 Measurement Result.....   | 24 |
| 6. Uncertainty of measurement.....  | 25 |
| 7. Laboratory description.....  | 26 |
| 7.1 Location: .....   | 26 |
| 7.2 Facility filing information: .....  | 26 |
| 8. Test photographs.....  | 27 |

## 1. Summary of Test

### 1.1 Purpose of test

It is the original test in order to verify conformance to FCC Part 15 Subpart C rules listed in Table A.

### 1.2 Summary of test results

Table-A: List of the measurements

| Test Items Section            | Test Items                                    |  |                   | Condition          | Result    |      |
|-------------------------------|---|--|-------------------|--------------------|-----------|------|
|                               | Transmit mode [Tx]:                           | Limit  |                   |                    |           |      |
| 15.215 (c)<br>RSS-Gen 4.6.1   | 20dB Bandwidth<br>99% Occupied bandwidth      | No limit   |                   |                    | Conducted | Pass |
| 15.209<br>15.225 (a)(b)(c)(d) | Operation within the band<br>13.110-14.010MHz | (a) The field strength of any emissions within the band 13.553-13.567MHz shall not exceed 15,848uV/m at 30m.<br>(b) Within the bands13.410-13.553MHz and 13.567-13.710MHz, the field strength of any emissions shall not exceed 334uV/m at 30m.<br>(c) Within the bands13.110-13.410MHz and 13.710-14.010MHz, the field strength of any emissions shall not exceed 106uV/m at 30m.<br>(d) The field strength of any emissions appearing outside of the 13.110-14.010MHz and shall not exceed the general radiated emission limits in 15.209. |                   |                    | Radiated  | Pass |
| 15.209<br>15.225(d)           | Transmitter radiated<br>spurious emissions    | <b>MHz</b>   | <b>Limits[uV]</b> | <b>Distance[m]</b> | Radiated  | Pass |
|                               |   | 0.009-0.490  | 2400/F(kHz)       | 300                |           |      |
|                               |   | 0.490-1.705  | 24000/F(kHz)      | 30                 |           |      |
|                               |   | 1.705-30.0   | 30                | 30                 |           |      |
|                               |   | 30-88  | 100               | 3                  |           |      |
|                               |   | 88-216   | 150               | 3                  |           |      |
|                               |   | 216-960  | 200               | 3                  |           |      |
| Above 960                     | 500   | 3  |                   |                    |           |      |
| 15.225(e)                     | Frequency tolerance                           | The frequency tolerance of the carrier signal shall be maintained within +/- 0.01% over a temperature variation of -30 degrees to +50 degrees C at normal supply voltage, and for a variation in the primary supply voltage from 85% to 115%of the rated supply voltage at a temperature of 20 degrees C.  |                   |                    | Conducted | Pass |
| 15.207                        | AC power line<br>conducted emissions          | <b>MHz</b>   | <b>QP[dBuV]</b>   | <b>AV[dBuV]</b>    | Conducted | Pass |
|                               |   | 0.15-0.50  | 66-56             | 56-46              |           |      |
|                               |   | 0.50-5   | 56                | 46                 |           |      |
|                               |   | 5-30   | 60                | 50                 |           |      |

## 2. Equipment description

---

### 2.1 EUT information

| No. | EUT                     | Company   | Model No.  | Serial No. | FCC ID/DoC  | Comment |
|-----|-------------------------|-----------|------------|------------|-------------|---------|
| 1   | ALVH ENTRANCE<br>READER | MIWA LOCK | ALVHDCU·DP | N/A        | VBU-ALVHDCU | EUT     |

Oscillator(s)/Crystal(s) : 13.56MHz

Power ratings : DC 3.0V

Port(s) : DC in  
I/O

Size : (W) 120 x (H) 162 x (D) 58.8 mm

Operating mode : Transmit mode

Variation of model(s) : Not applicable

[RF Specification]

Frequency Range : 13.56MHz

Antenna (Rx and Tx) : Integral antenna

## 2.2 Operating flow

### 2.2.1 Operating condition

The test was carried out under the following conditions during the test.

### 2.2.2 Test mode

Following programs were performed continuously.

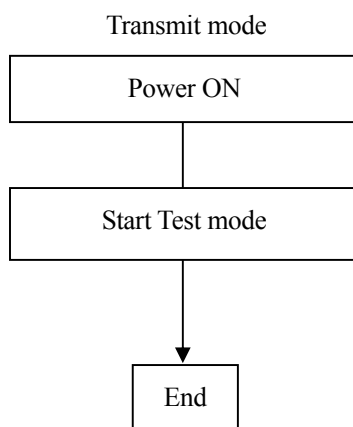

### 3. Configuration information

#### 3.1 Peripheral(s) used

| No. | Equipment    | Company              | Model No. | Serial No. | DoC / FCC ID | Comment |
|-----|--------------|----------------------|-----------|------------|--------------|---------|
| 2   | Power supply | Agilent Technologies | 6236B     | 02140320   | N/A          | -       |

#### 3.2 Cable(s) information

| No. | Cable         | Length [m] | Shield     | Connector | From         | To           | Comment   |
|-----|---------------|------------|------------|-----------|--------------|--------------|-----------|
| a   | DC cable      | 1.2        | Unshielded | Plastic   | EUT          | Power supply | -         |
| b   | FG cable      | 3.5        | Unshielded | Plastic   | EUT          | Ground plane | Accessory |
| c   | AC cable      | 2.0        | Unshielded | Plastic   | Power supply | AC outlet    | -         |
| d   | Control cable | 0.06       | Unshielded | Plastic   | EUT          | -            | -         |

#### 3.3 System configuration

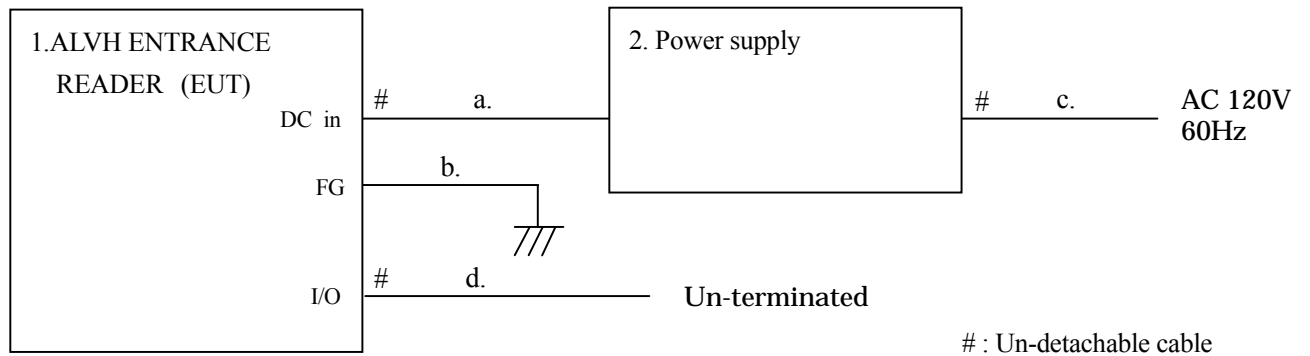

Note 1: Numbers assigned to equipment or cables on this diagram are corresponded to the list in "2.1 EUT information", "3.1 Peripheral(s) used" and "3.2 Cable(s) information".

## 4. Test Instruments

### List of Measuring Instruments

| Equipment                             | Company                | Model No.                | Serial No.  | Cal. due  | Cal. date     |
|---------------------------------------|------------------------|--------------------------|-------------|-----------|---------------|
| Spectrum Analyzer<br>(5Hz – 42.98GHz) | Agilent Technologies   | E4447A                   | MY46180188  | Feb. 2009 | Feb. 12, 2008 |
| Spectrum Analyzer<br>(9kHz – 3.0GHz)  | Agilent Technologies   | E4403B                   | MY44212805  | Oct. 2008 | Oct. 3, 2007  |
| Preamplifier<br>(100kHz-1.2GHz)       | ANRITSU                | MH648A                   | M96057      | Jun. 2008 | Jun. 25, 2007 |
| Preamplifier<br>(1GHz-26.5GHz)        | Agilent Technologies   | 8449B                    | 3008A01008  | Dec. 2009 | Dec. 11, 2007 |
| EMI Receiver                          | ROHDE&SCHWARZ          | ESCI                     | 100451      | May. 2008 | May. 10, 2007 |
| Loop Antenna                          | ROHDE&SCHWARZ          | HFH2-Z2                  | 891847/17   | Feb. 2009 | Feb. 14, 2008 |
| Biconical Antenna                     | Schwarzbeck            | VHA9103/BBA9106          | 2323        | Jun. 2008 | Jun. 16, 2007 |
| Attenuator(6dB)                       | TDC                    | TAT-43B-06               | N/A         | Jun. 2008 | Jun. 22, 2007 |
| Log Periodic Antenna                  | Schwarzbeck            | UHALP9108A               | 0589        | Jun. 2008 | Jun. 16, 2007 |
| Attenuator(3dB)                       | TDC                    | TAT-43B-03               | N/A         | Aug. 2008 | Aug. 8, 2007  |
| Coaxial cable                         | Fujikura               | 5D-2W/10m                | #AEC3R-001  | Feb. 2009 | Feb. 14, 2008 |
|                                       |                        | 5D-2W/1.5m               | #AEC3RC-001 | Feb. 2009 | Feb. 14, 2008 |
|                                       |                        | 5D-2W/1m                 | #AEC3RC-002 | Feb. 2009 | Feb. 14, 2008 |
|                                       |                        | 5D-2W/1m                 | #AEC3RC-003 | Feb. 2009 | Feb. 14, 2008 |
| Coaxial cable                         | N/A                    | N/A                      | N/A         | Apr. 2008 | Apr. 1, 2007  |
| Coaxial Switch                        | ANRITSU                | MP59B                    | 6200611581  | Feb. 2009 | Feb. 14, 2008 |
| EMI Probe                             | FerriShield            | CTM032                   | N/A         | N/A       | N/A           |
| Operation Type<br>Temperature Chamber | Espec                  | PL-3KP                   | 14016727    | Mar. 2008 | Mar. 20, 2007 |
| Site attenuation                      | ZACTA Technology Corp. | 3m Semi-anechoic chamber | N/A         | May. 2008 | May. 12, 2007 |

\*The calibrations of the above equipment are traceable to NIST or equivalent standards of the reference organizations.



## 5. Test Type and Results

---

### 5.1 20dB Bandwidth / 99% Occupied Bandwidth

#### 5.1.1 Test Procedure [ FCC 15.215 (c), IC RSS-Gen. 4.6.1 ]

The measurement was performed under the condition which has the maximum Electric field strength.

The spectrum analyzer is set to:

- RBW=3kHz, VBW=10kHz, Span=100kHz, Sweep=auto

The test mode of EUT is as follows.

- Transmit mode

#### 5.1.2 Test Instruments and Measurement Setup

##### Test configuration for 20dB Bandwidth/99% Occupied Bandwidth

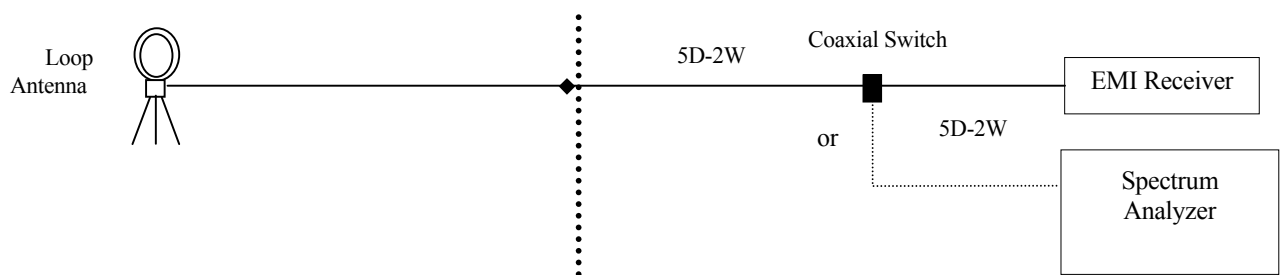

#### 5.1.3 Limit of Bandwidth at 20dB Bandwidth/99% Occupied Bandwidth

None

### 5.1.4 Measurement Result

[Transmit mode]

| Frequency [MHz] | 20dB Bandwidth [kHz] | Occupied Bandwidth [kHz] |
|-----------------|----------------------|--------------------------|
| 13.56           | 8.937                | 10.0685                  |

### 5.1.5 Trace Data

**Test Personnel:**

Tested by: Hiroaki Suzuki

Date : Apr. 21, 2008  
Temperature : 20.6 [°C]  
Humidity : 31.7 [%]  
Test place : 3m Semi-anechoic chamber

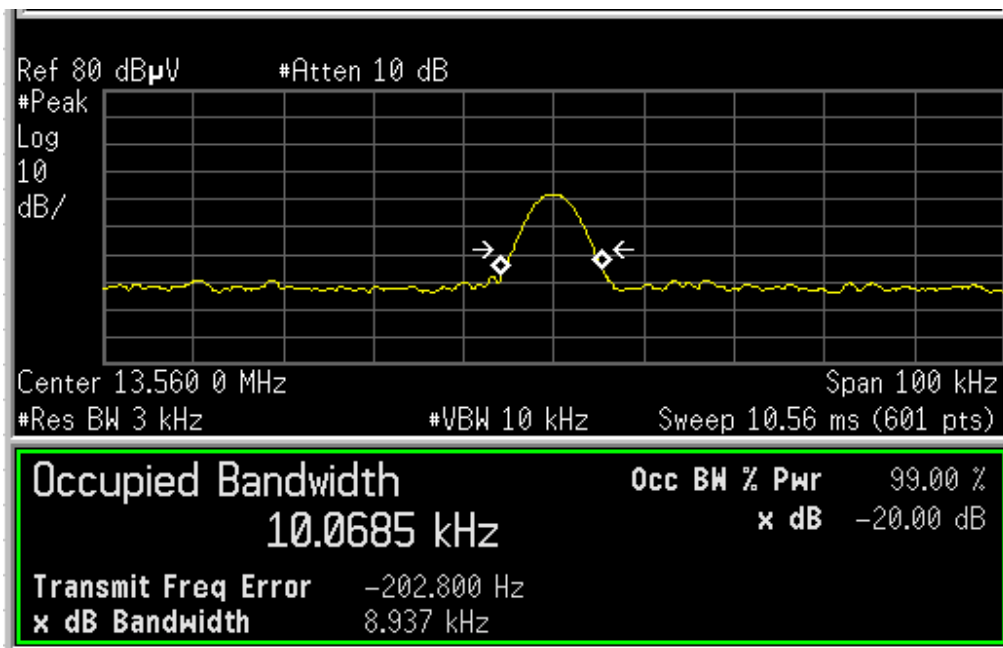

## 5.2 Operation within the band 13.110-14.010MHz

### 5.2.1 Test Procedure [ FCC 15.209/15.225(a)(b)(c)(d) ]

Radiated emission measurements are performed at 10m distance with the Loop antenna. The Loop antenna is positioned with its plane vertical, and the center of the Loop is 1.0meter above the ground plane. Frequency Range: 13MHz –14.12MHz is scanned and investigated with the test receiver, and with the spectrum analyzer. The detector function of the test receiver is set to CISPR Quasi-peak mode and the bandwidth is set to 9kHz.

The EUT and support equipment are placed on a 1 meter x 2.0 meter surface, 0.8 meter height FRP table. The turntable and the loop antenna are rotated by 360 degrees and stopped at azimuth of producing the maximum emission.

Interconnecting cables, which hanging closer than 40cm to the horizontal metal ground plane are bundled its excess in center. The test results represent the worst-case emission for each emission with manipulating the EUT, support equipment, interconnecting cables and varying the mode of operation.

Sufficient time for the EUT, support equipment, and test equipment are allowed in order for them to warm up to their normal operating condition.

### 5.2.2 Test Instruments and Measurement Setup

#### Test configuration for Operation within the band 13.110-14.010MHz

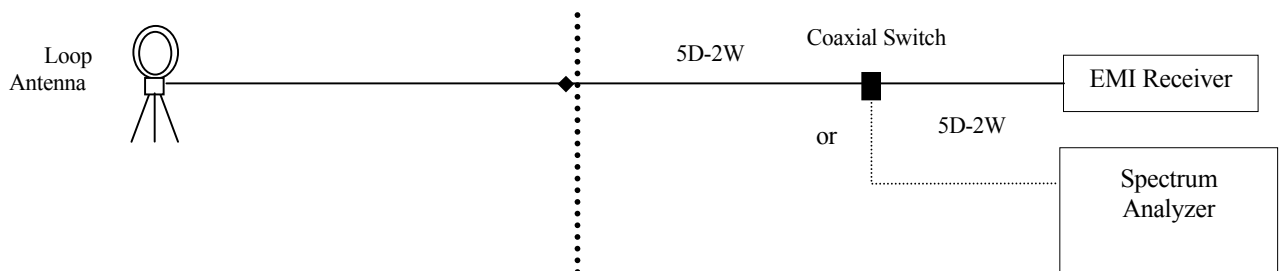

### 5.2.3 Limit of Operation within the band 13.110-14.010MHz

- The field strength of any emissions within the band 13.553-13.567MHz shall not exceed 15,848uV/m at 30m.
- Within the band 13.410-13.553MHz and 13.567-13.710MHz, the field strength of any emissions shall not exceed 334uV/m at 30m.
- Within the band 13.110-13.410MHz and 13.710-14.010MHz, the field strength of any emissions shall not exceed 106uV/m at 30m.
- The field strength of any emissions appearing outside of the 13.110-14.010MHz and shall not exceed the general radiated emission limits in FCC 15.209.

**5.2.4 Measurement Result**

**[Transmit mode]**

| Frequency Range<br>[MHz] | Frequency<br>[MHz] | Level                      |                             | Limit<br>[dBuV/m] | Margin<br>[dBuV/m] | Result |
|--------------------------|--------------------|----------------------------|-----------------------------|-------------------|--------------------|--------|
|                          |                    | Measured at 3m<br>[dBuV/m] | Measured at 30m<br>[dBuV/m] |                   |                    |        |
| 13.553-13.567            | 13.560             | 59.7                       | 19.7                        | 84.0              | 64.3               | PASS   |
| 13.410-13.553            | 13.553             | 49.2                       | 9.2                         | 50.5              | 41.3               | PASS   |
| 13.567-13.710            | 13.567             | 47.6                       | 7.6                         | 50.5              | 42.9               | PASS   |

Note. Measurements were corrected to 30m using  $40\log(3/30) = -40.0\text{dB}$

### 5.2.5 Trace Data

[Horizontal Installation]

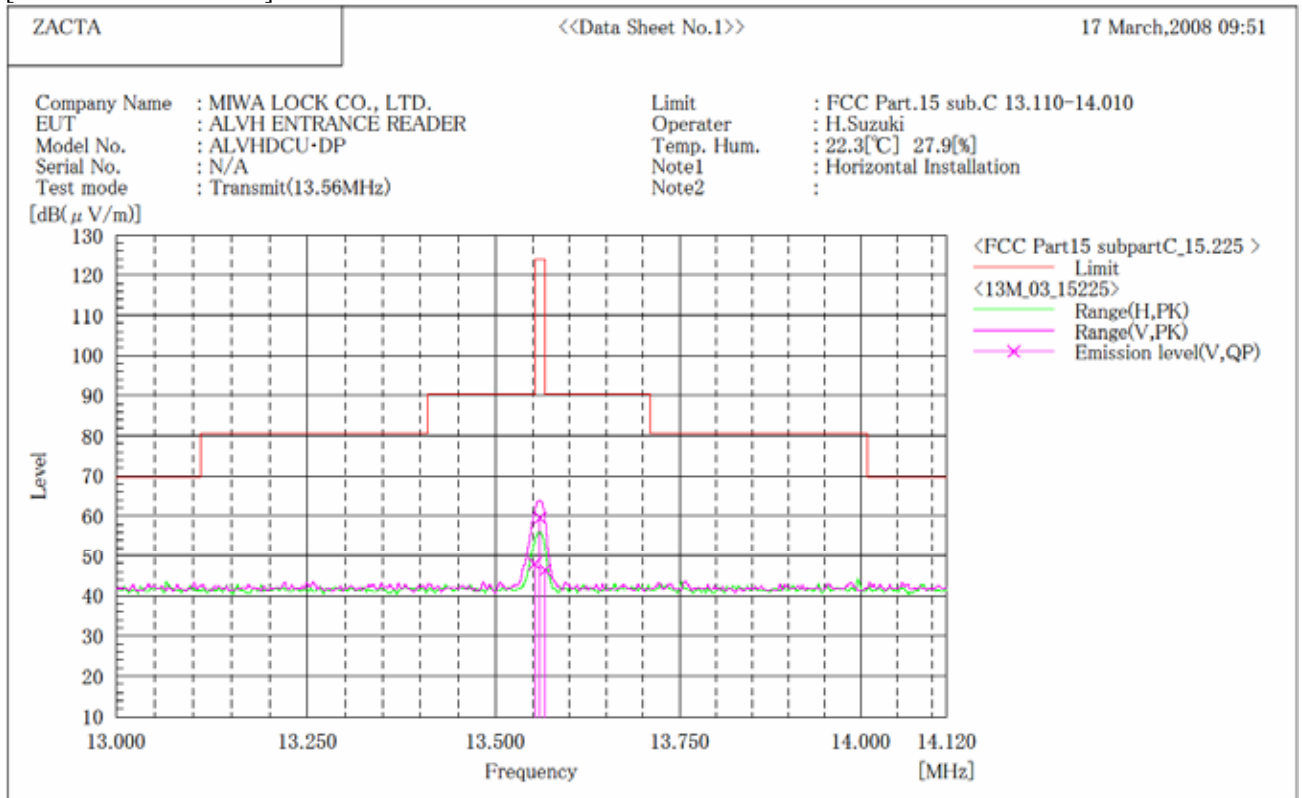

#### Final Result

| No. | Frequency [MHz] | (P) | Reading QP [dB(μV)] | c. f [dB(1/m)] | Result QP [dB(μV/m)] | Limit [dB(μV/m)] | Margin QP [dB] | Height [cm] | Angle [°] |
|-----|-----------------|-----|---------------------|----------------|----------------------|------------------|----------------|-------------|-----------|
| 1   | 13.553          | V   | 28.4                | 19.5           | 47.9                 | 90.5             | 42.6           | 100.0       | 205.0     |
| 2   | 13.560          | V   | 40.1                | 19.5           | 59.6                 | 124.0            | 64.4           | 100.0       | 205.0     |
| 3   | 13.567          | V   | 26.9                | 19.5           | 46.4                 | 90.5             | 44.1           | 100.0       | 205.0     |

[Vertical Installation]

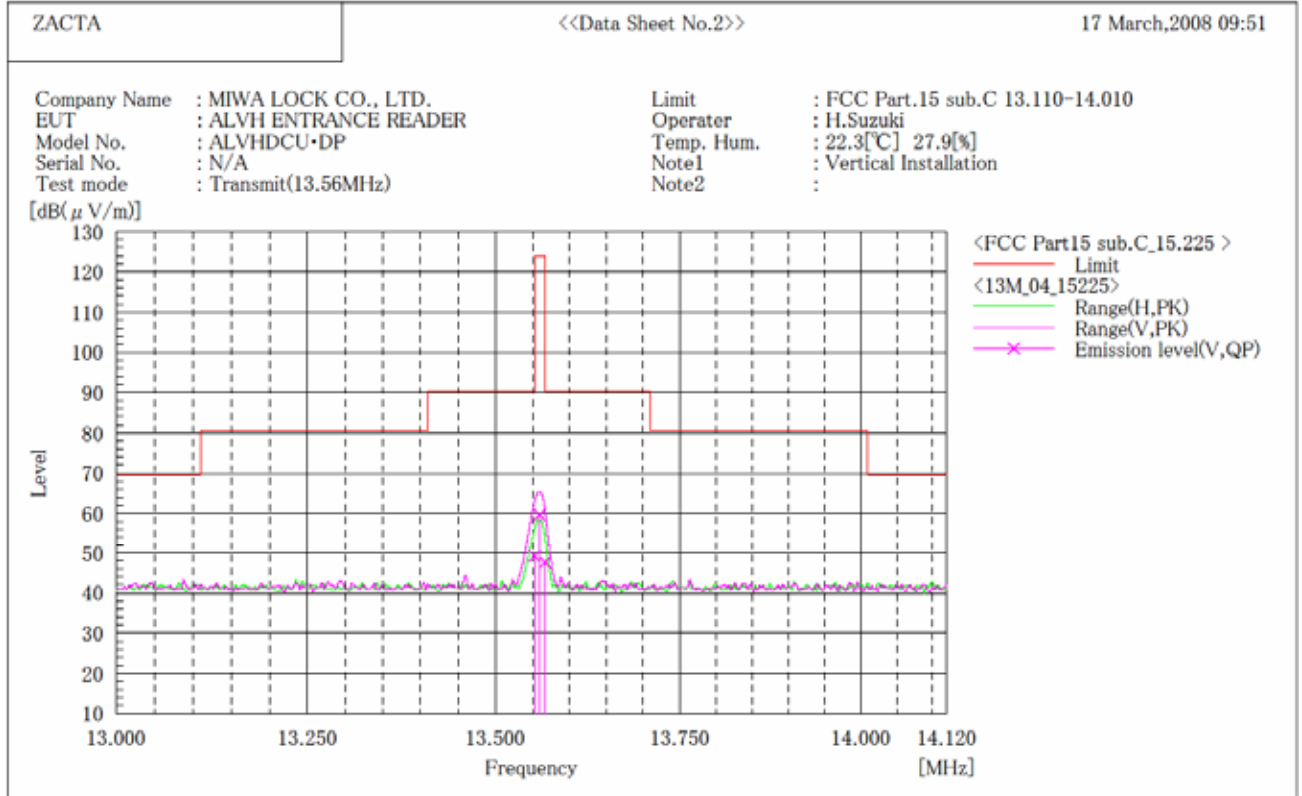

Final Result

| No. | Frequency [MHz] | (P) | Reading QP [dB(μV)] | c. f [dB(1/m)] | Result QP [dB(μV/m)] | Limit [dB(μV/m)] | Margin QP [dB] | Height [cm] | Angle [°] |
|-----|-----------------|-----|---------------------|----------------|----------------------|------------------|----------------|-------------|-----------|
| 1   | 13.553          | V   | 29.7                | 19.5           | 49.2                 | 90.5             | 41.3           | 100.0       | 219.0     |
| 2   | 13.560          | V   | 40.2                | 19.5           | 59.7                 | 124.0            | 64.3           | 100.0       | 219.0     |
| 3   | 13.567          | V   | 28.1                | 19.5           | 47.6                 | 90.5             | 42.9           | 100.0       | 219.0     |

### 5.3 Transmitter Radiated Spurious Emissions (9kHz-1000MHz)

#### 5.3.1 Test Procedure [ FCC 15.209/225(d) ]

Radiated emission measurements are performed at 3m distance with the broadband antenna (Loop antenna, Biconical antenna, log-periodic antenna.). The antenna is positioned both the horizontal and vertical planes of polarization and height is varied 1 to 4 meters and stopped at height producing the maximum emission. As for the Loop antenna, it is positioned with its plane vertical, and the center of the Loop is 1.0meter above the ground plane. Frequency Range: 9kHz –1GHz is scanned and investigated with the test receiver, and above 1GHz, with the spectrum analyzer. The detector function of the test receiver is set to CISPR Quasi-peak mode and the bandwidth is set to 9kHz (below 30MHz) and 120kHz (above 30MHz).

The EUT and support equipment are placed on a 1 meter x 2.0 meter surface, 0.8 meter height FRP table. The turntable and the loop antenna are rotated by 360 degrees and stopped at azimuth of producing the maximum emission.

Interconnecting cables, which hanging closer than 40cm to the horizontal metal ground plane are bundled its excess in center. The test results represent the worst-case emission for each emission with manipulating the EUT, support equipment, interconnecting cables and varying the mode of operation.

Sufficient time for the EUT, support equipment, and test equipment are allowed in order for them to warm up to their normal operating condition.

#### 5.3.2 Test Instruments and Measurement Setup

##### Test configuration for Spurious Emissions

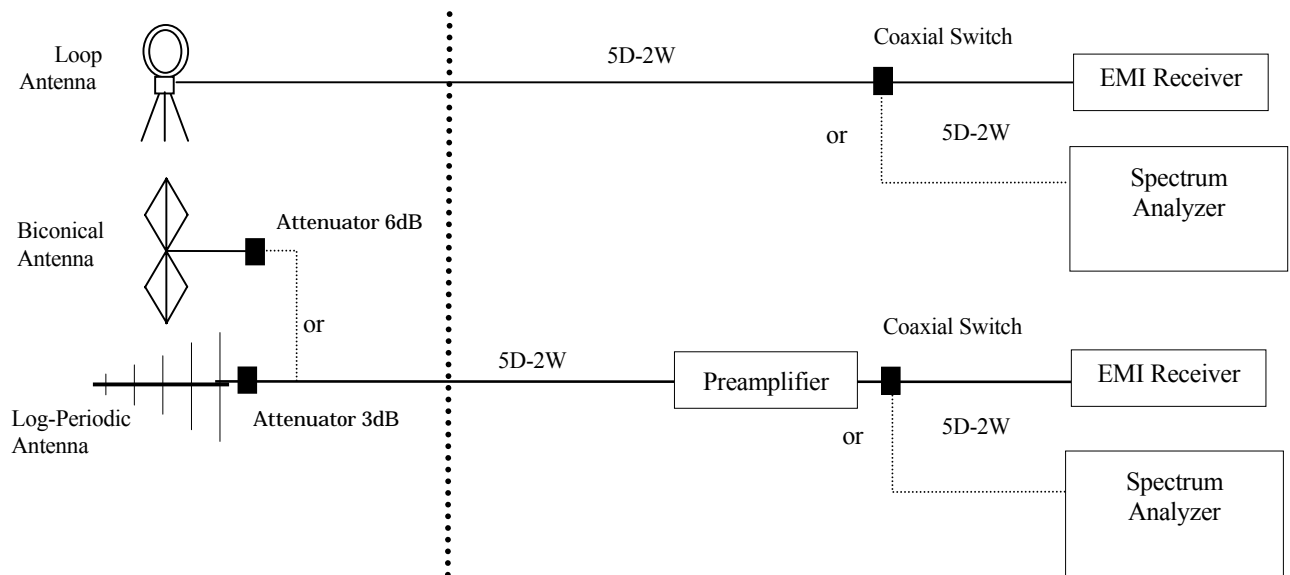

### 5.3.3 Limit of Spurious Emissions Measurement

| Frequency<br>[MHz] | Field Strength  |               |
|--------------------|-----------------|---------------|
|                    | [uV/m]          | [dBuV/m]      |
| 0.009 – 0.490      | 2400 / F [kHz]  | 20logE [uV/m] |
| 0.490 – 1.705      | 24000 / F [kHz] | 20logE [uV/m] |
| 1.705-30           | 30              | 29.5          |
| 30 – 88            | 100             | 40.0          |
| 88 – 216           | 150             | 43.5          |
| 216 – 960          | 200             | 46.0          |
| Above 960          | 500             | 54.0          |

NOTE:

1. The lower limit shall apply at the transition frequencies.
2. Emission level [dBuV/m] = 20 log Emission [uV/m]

### 5.3.4 Sample of field strength calculation

**Spurious Emission**       $\text{dB}\mu\text{V/m} = 20\log_{10}(\mu\text{V/m})$

|  |
|--|
| Limit @147.6MHz = 150μV/m = 43.5dBμV/m                             |
| Reading = 42.8dBμV   |
| Ant. Factor + Cable Loss - Amp. Gain = 14.2 + 3.0 - 30.0 = -12.8dB |
| Total = 42.8 - 12.8 = 30.0dBμV/m                                   |
| Margin = 43.5 - 30.0 = <u>13.5dB</u>                               |

### 5.3.5 Measurement Result

**Test Personnel:**

Tested by: Hiroaki Suzuki

Date : Mar. 17, 2008  
 Temperature : 22.3 [°C]  
 Humidity : 27.9 [%]  
 Test place : 3m Semi-anechoic chamber

1) 0.009-30MHz

| Frequency<br>[MHz] | Level                      |                             | Limit<br>[dBuV/m] | Margin<br>[dBuV/m] | Result |
|--------------------|----------------------------|-----------------------------|-------------------|--------------------|--------|
|                    | Measured at 3m<br>[dBuV/m] | Measured at 30m<br>[dBuV/m] |                   |                    |        |
| 13.560             | 59.7                       | 19.7                        | 29.5              | 9.8                | PASS   |

Note. Measurements were corrected to 30m using  $40\log(3/30) = -40.0\text{dB}$



[Horizontal Installation] 0.009-30MHz

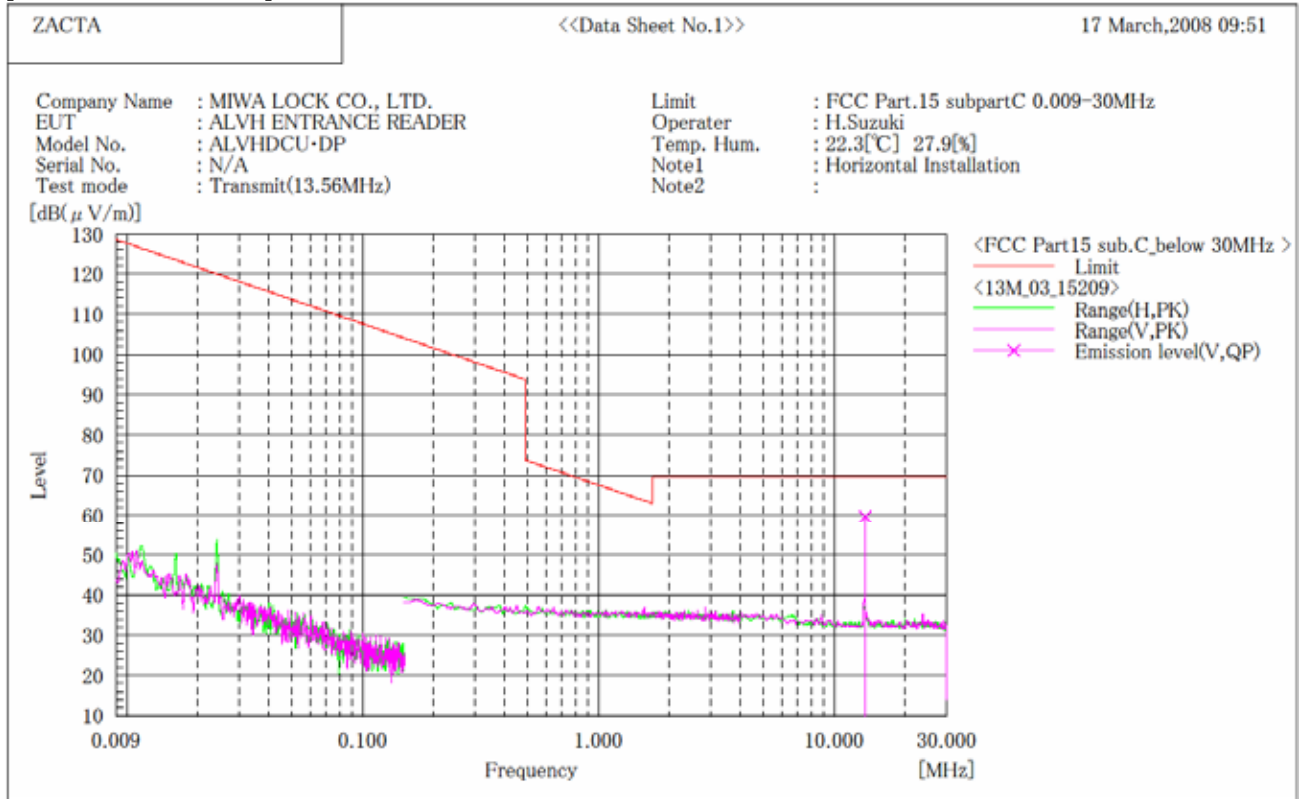

Final Result

| No. | Frequency | (P) | Reading  | c. f      | Result     | Limit      | Margin | Height | Angle |
|-----|-----------|-----|----------|-----------|------------|------------|--------|--------|-------|
|     | [MHz]     |     | QP       | [dB(1/m)] | QP         | [dB(μV/m)] | QP     | [cm]   | [°]   |
|     |           |     | [dB(μV)] |           | [dB(μV/m)] | [dB(μV/m)] | [dB]   |        |       |
| 1   | 13.560    | V   | 40.1     | 19.5      | 59.6       | 69.5       | 9.9    | 100.0  | 205.0 |

[Vertical Installation] 0.009-30MHz

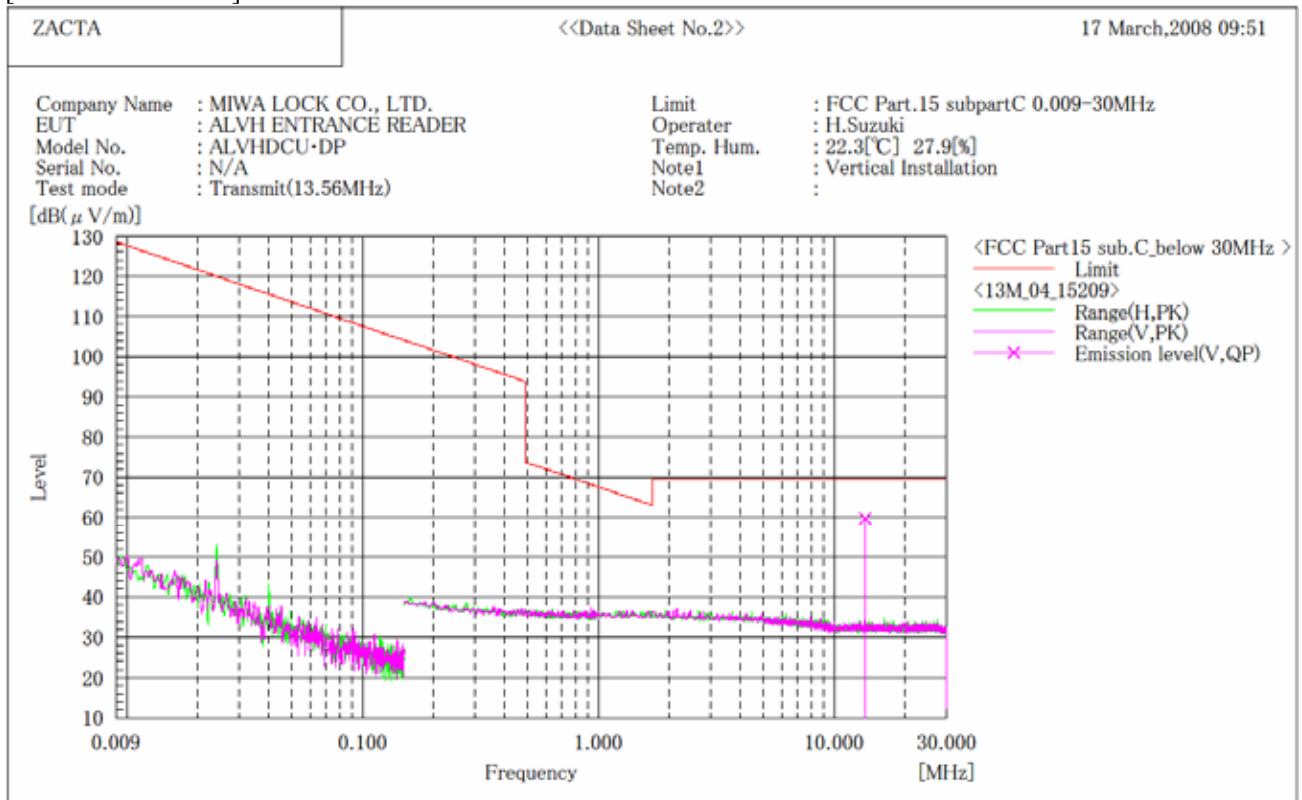

Final Result

| No. | Frequency<br>[MHz] | (P) | Reading<br>QP<br>[dB(μV)] | c. f<br>[dB(1/m)] | Result<br>QP<br>[dB(μV/m)] | Limit<br>[dB(μV/m)] | Margin<br>QP<br>[dB] | Height<br>[cm] | Angle<br>[°] |
|-----|--------------------|-----|---------------------------|-------------------|----------------------------|---------------------|----------------------|----------------|--------------|
| 1   | 13.560             | V   | 40.2                      | 19.5              | 59.7                       | 69.5                | 9.8                  | 100.0          | 219.0        |

2) 30-1000MHz

[Horizontal Installation] 30-1000MHz

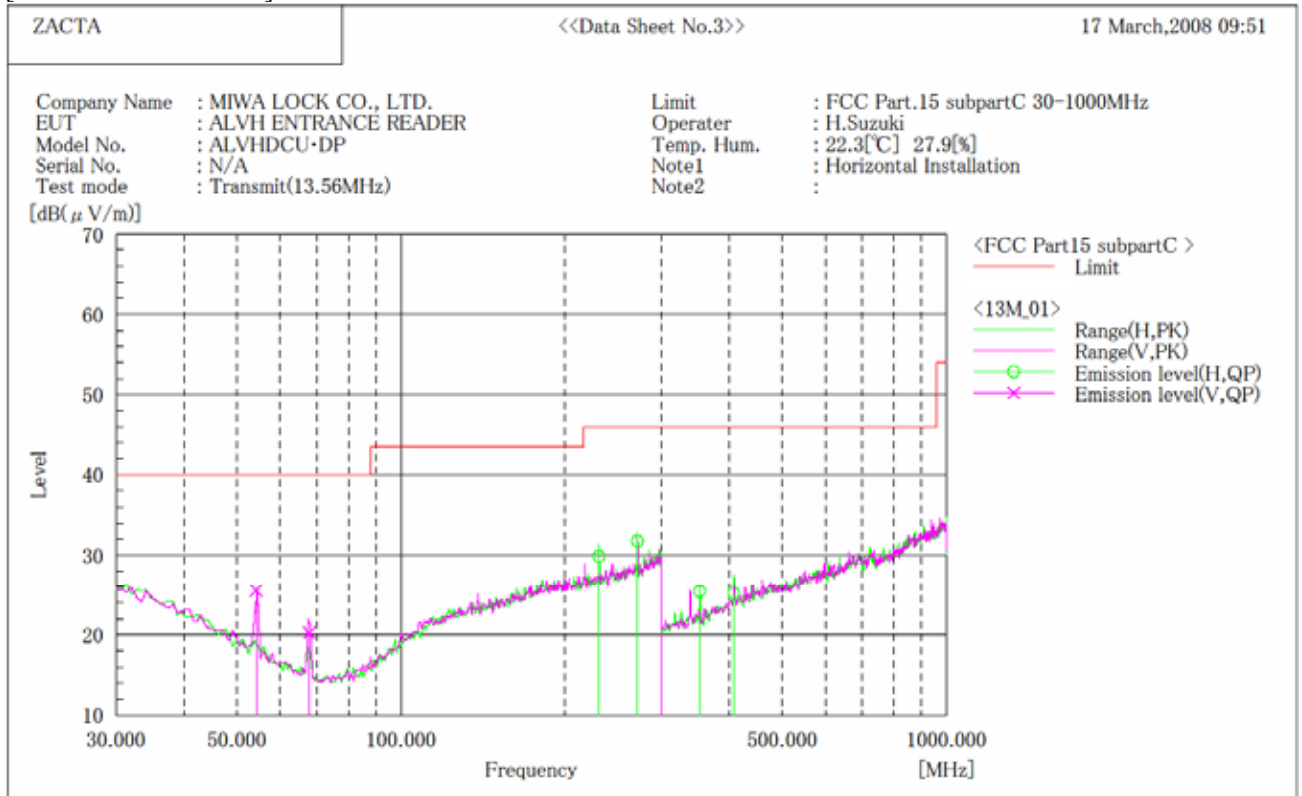

Final Result

| No. | Frequency<br>[MHz] | (P) | Reading<br>QP<br>[dB(μV)] | c. f<br>[dB(1/m)] | Result<br>QP<br>[dB(μV/m)] | Limit<br>[dB(μV/m)] | Margin<br>QP<br>[dB] | Height<br>[cm] | Angle<br>[°] |
|-----|--------------------|-----|---------------------------|-------------------|----------------------------|---------------------|----------------------|----------------|--------------|
| 1   | 54.240             | V   | 38.6                      | -13.1             | 25.5                       | 40.0                | 14.5                 | 100.0          | 18.0         |
| 2   | 67.800             | V   | 36.2                      | -15.9             | 20.3                       | 40.0                | 19.7                 | 100.0          | 2.0          |
| 3   | 230.520            | H   | 34.2                      | -4.3              | 29.9                       | 46.0                | 16.1                 | 130.0          | 112.0        |
| 4   | 271.220            | H   | 35.0                      | -3.2              | 31.8                       | 46.0                | 14.2                 | 381.0          | 88.0         |
| 5   | 352.550            | H   | 34.6                      | -9.2              | 25.4                       | 46.0                | 20.6                 | 100.0          | 235.0        |
| 6   | 406.800            | H   | 32.6                      | -7.4              | 25.2                       | 46.0                | 20.8                 | 100.0          | 113.0        |

[Vertical Installation] 30-1000MHz

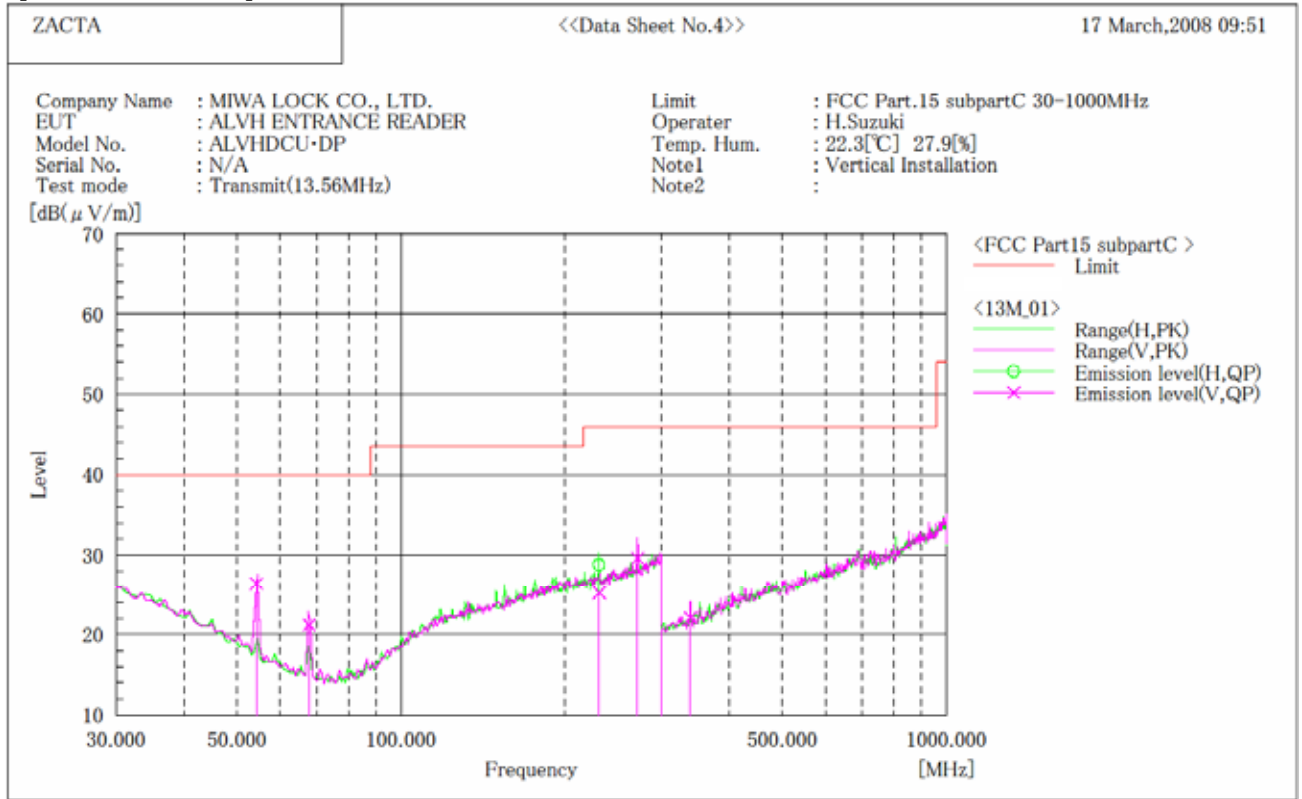

Final Result

| No. | Frequency [MHz] | (P) | Reading QP [dB(μV)] | c. f [dB(1/m)] | Result QP [dB(μV/m)] | Limit [dB(μV/m)] | Margin QP [dB] | Height [cm] | Angle [°] |
|-----|-----------------|-----|---------------------|----------------|----------------------|------------------|----------------|-------------|-----------|
| 1   | 54.240          | V   | 39.5                | -13.1          | 26.4                 | 40.0             | 13.6           | 100.0       | 7.0       |
| 2   | 67.800          | V   | 37.1                | -15.9          | 21.2                 | 40.0             | 18.8           | 100.0       | 2.0       |
| 3   | 230.520         | V   | 29.5                | -4.3           | 25.2                 | 46.0             | 20.8           | 100.0       | 255.0     |
| 4   | 271.200         | V   | 32.8                | -3.2           | 29.6                 | 46.0             | 16.4           | 100.0       | 2.0       |
| 5   | 339.000         | V   | 31.6                | -9.5           | 22.1                 | 46.0             | 23.9           | 113.0       | 188.0     |
| 6   | 230.520         | H   | 33.1                | -4.3           | 28.8                 | 46.0             | 17.2           | 124.0       | 114.0     |

## 5.4 Frequency Tolerance

### 5.4.1 Test Procedure [ FCC 15.225(e) ]

The Frequency tolerance is measured with a spectrum analyzer connected to the antenna terminal, while EUT is operating in transmission mode at the appropriate center frequency.

The spectrum analyzer is set to:

- RBW= 9kHz, VBW=30kHz, Span=50kHz, Sweep = 100m sec.

### 5.4.2 Test Instruments and Measurement Setup

#### Test configuration for Frequency Tolerance

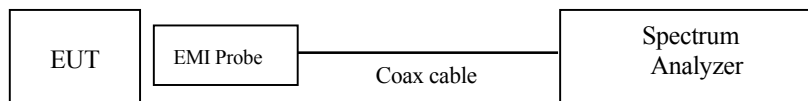

### 5.4.3 Limit of Frequency Tolerance

The Frequency tolerance of the carrier signal shall be maintained within +/- 0.01% over a temperature variation of -30 degrees to +50 degrees C at normal supply voltage, and for a variation in the primary supply voltage from 85% to 115% of the rated supply voltage at a temperature of 20 degrees C.

### 5.4.4 Measurement Result

#### Test Personnel:

Tested by: Hiroaki Suzuki

Date : Mar. 17, 2008  
 Temperature : 21.0 [°C]  
 Humidity : 36.0 [%]  
 Test place : Shielded room

| Reference Frequency: EUT Channel 13.56MHz at 20°C |                 |                              |                           |             |             |
|---|-----------------|------------------------------|---------------------------|-------------|-------------|
| Limit: ±0.01% = ±100ppm = 0.135603MHz             |                 |                              |                           |             |             |
| Power Supply [V]                                  | Temperature [ ] | Measurements Frequency [MHz] | Frequency Tolerance [ppm] | Limit [ppm] | PASS / FAIL |
| 3.00  | 50              | 13.5602                      | -7.374468116              | ±100        | PASS        |
|   | 40              | 13.5598                      | -36.87234058              | ±100        | PASS        |
|   | 30              | 13.5600                      | -22.12340435              | ±100        | PASS        |
|   | <b>20</b>       | <b>13.5603</b>               | -                         | ±100        | PASS        |
|   | 10              | 13.5607                      | 29.49787247               | ±100        | PASS        |
|   | 0               | 13.5602                      | -7.374468116              | ±100        | PASS        |
|   | -10             | 13.5595                      | -58.99574493              | ±100        | PASS        |
|   | -20             | 13.5600                      | -22.12340435              | ±100        | PASS        |
|   | -30             | 13.5607                      | 29.49787247               | ±100        | PASS        |
| 2.55  | 20              | 13.5598                      | -36.87234058              | ±100        | PASS        |
| 3.45  | 20              | 13.5595                      | -58.99574493              | ±100        | PASS        |

Calculation :

Frequency Tolerance (ppm) = Measurements Frequency (MHz) – Reference Frequency (MHz) / Reference Frequency (MHz) x 1000000

## 5.5 AC power line Conducted Emissions

### 5.5.1 Test Procedure [ FCC 15.207 ]

Conducted emission at AC mains port measurements are performed at open area test site according to ANSI C63.4 section 7.

EUT and support equipment are placed on wooden table of 2.3m(W) × 1.0m(D) × 0.8m(H) in size. EUT is connected to 50Ω/50μH Line Impedance Stabilization Network (LISN) which is placed on reference ground plane, and was placed 80cm away from EUT. Excess of AC power cable is bundled in center. Vertical Metal Reference Plane 2.4m (W) × 2.7m (H) in size is placed 0.4m away from EUT. LISN for peripheral is terminated in 50Ω.

EUT operating mode is selected to emit the maximum noise. Overall frequency range is investigated with spectrum analyzer using peak detector. Maximum emission configuration is determined by manipulating the EUT, support equipment, interconnecting cables. Then, emission measurements are performed with test receiver in above setting to each current-carrying conductor of the mains port. Sufficient time for EUT, support equipment and test equipment are provided in order for them to warm up to their normal operating condition.

Frequency range:

- 0.15MHz to 30MHz

The Test receiver is set to:

- Detector: Quasi-peak, Average  
Bandwidth: 9kHz

### 5.5.2 Test Instruments and Measurement Setup

#### Test configuration for AC power line Conducted Emissions

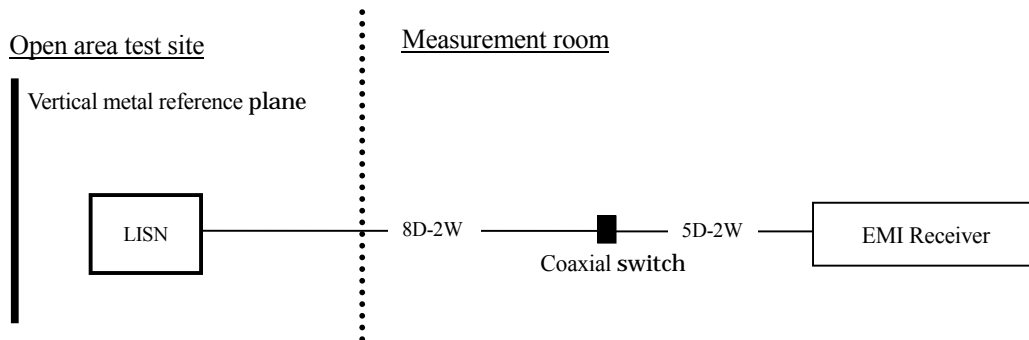

**5.5.3 Test equipment for AC power line Conducted Emissions**

| Equipment                                    | Company                         | Model No.      | Serial No.       | Cal. due  | Cal. Date     |
|--|---------------------------------|----------------|------------------|-----------|---------------|
| EMI Receiver                                 | ROHDE&SCHWARZ                   | ESCI           | 100451           | May. 2008 | Mar. 10, 2007 |
| Line impedance stabilization network for EUT | Kyoritsu Electrical Works, Ltd. | KNW-407        | 8-693-20         | Mar. 2009 | Mar. 13, 2008 |
| Coaxial cable                                | FUJIKURA                        | 8D-2W/15m      | YTCRFC#2C        | Jun. 2008 | Jun. 23, 2007 |
| Coaxial cable                                | FUJIKURA                        | 5D-2W/1m       | YTCRFC#2R,2C-001 | Jun. 2008 | Jun. 23, 2007 |
| Coaxial switch                               | ANRITSU                         | MP59B          | 6200331882       | Jun. 2008 | Jun. 23, 2007 |
| PC   | IBM                             | 6892-44J       | 97-42089         | N/A       | N/A           |
| Software                                     | ZACTA                           | EMI Data Sheet | Ver.2.81         | N/A       | N/A           |

**5.5.4 Limit of AC power line Conducted Emissions Measurement (Sample calculation)**

| Frequency         | Limit     |           | Sample of field strength calculation   |
|-------------------|-----------|-----------|--|
|                   | QP(dBμV)  | AV(dBμV)  |  |
| 0.15MHz to 0.5MHz | 66 to 56* | 56 to 46* | $dB\mu V = 20\log_{10}(\mu V)$ Limit @ : 60.0dBμV(Quasi-peak)<br>6.770MHz : 50.0dBμV(Average)<br><br>(Quasi peak) Reading = 51.2dBμV<br>Cable loss + AMN factor = 0.3dB<br>Total = 51.2 + 0.3 = 51.5dBμV<br>Margin = 60.0 – 51.5 = 8.5dB<br><br>(Average) Reading = 45.0dBμV<br>Cable loss + AMN factor = 0.3dB<br>Total = 45.0 + 0.3 = 45.3dBμV<br>Margin = 50.0 – 45.3 = 4.7dB |
| 0.5MHz to 5MHz    | 56        | 46        |  |
| 5MHz to 30MHz     | 60        | 50        |  |

\*: The limit decreases linearly with the logarithm of the frequency in the range 0.15MHz to 0.5MHz.

### 5.5.5 Measurement Result

\*\*\*\*\* CONDUCTED EMISSION at MAINS PORT \*\*\*\*\*

Sheet number : 1

Standard : FCC Part 15 Subpart C  
 Class : N/A  
 Terminal : Mains  
 Date of test : 2008/3/26  
 Test site : 2  
 Temperature [ ] : 16.5  
 Humidity [%] : 34.2  
 Operator : H.Suzuki  
 Company name : MIWA LOCK CO., LTD.  
 EUT : ALVH ENTRANCE READER  
 Model number : ALVHDCU · DP  
 Serial number : N/A  
 Test mode : Transmit mode  
 Comment : 13.56MHz

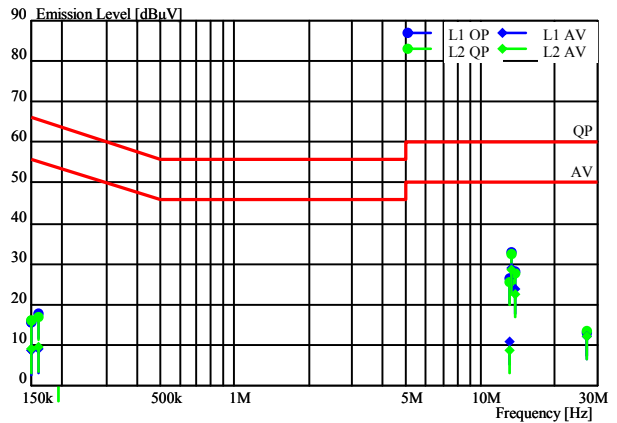

| Phase | Frequency [MHz] | Reading |      | Factor [dB] | Emission level [dBμV] |      | Limit [dBμV] |      | Margin [dB] |      | Comment |
|-------|-----------------|---------|------|-------------|-----------------------|------|--------------|------|-------------|------|---------|
|       |                 | QP      | AV   |             | QP                    | AV   | QP           | AV   | QP          | AV   |         |
| L1    | 0.150           | 15.2    | 8.3  | 0.2         | 15.4                  | 8.5  | 66.0         | 56.0 | 50.6        | 47.5 |         |
| L1    | 0.160           | 17.4    | 8.8  | 0.2         | 17.6                  | 9.0  | 65.5         | 55.5 | 47.9        | 46.5 |         |
| L1    | 13.020          | 25.6    | 10.1 | 0.7         | 26.3                  | 10.8 | 60.0         | 50.0 | 33.7        | 39.2 |         |
| L1    | 13.376          | 32.1    | 28.2 | 0.7         | 32.8                  | 28.9 | 60.0         | 50.0 | 27.2        | 21.1 | *       |
| L1    | 13.740          | 27.5    | 22.9 | 0.7         | 28.2                  | 23.6 | 60.0         | 50.0 | 31.8        | 26.4 |         |
| L1    | 27.120          | 11.6    | 10.8 | 1.5         | 13.1                  | 12.3 | 60.0         | 50.0 | 46.9        | 37.7 |         |
| L2    | 0.150           | 15.8    | 8.8  | 0.2         | 16.0                  | 9.0  | 66.0         | 56.0 | 50.0        | 47.0 |         |
| L2    | 0.160           | 16.8    | 9.2  | 0.2         | 17.0                  | 9.4  | 65.5         | 55.5 | 48.5        | 46.1 |         |
| L2    | 13.020          | 25.0    | 8.1  | 0.7         | 25.7                  | 8.8  | 60.0         | 50.0 | 34.3        | 41.2 |         |
| L2    | 13.375          | 31.7    | 27.7 | 0.7         | 32.4                  | 28.4 | 60.0         | 50.0 | 27.6        | 21.6 |         |
| L2    | 13.740          | 26.8    | 22.0 | 0.7         | 27.5                  | 22.7 | 60.0         | 50.0 | 32.5        | 27.3 |         |
| L2    | 27.120          | 11.7    | 10.8 | 1.5         | 13.2                  | 12.3 | 60.0         | 50.0 | 46.8        | 37.7 |         |

\* : The worst emission.

Factor : LISN Factor + Cable Loss

Ver.2.81 F2#031



## ***6. Uncertainty of measurement***

---

Expanded uncertainties stated were calculated with a coverage Factor  $k=2$ .

Please note that these results are not taken into account when determining compliance or non-compliance with test result.

| <b>Test item</b>                                  | <b>Measurement uncertainty</b> |
|---|--------------------------------|
| Conducted emission at mains port (150kHz - 30MHz) | $\pm 2.9\text{dB}$             |
| Radiated emission (9kHz - 30MHz)                  | $\pm 4.4\text{dB}$             |
| Radiated emission (30MHz – 300MHz)                | $\pm 4.6\text{dB}$             |
| Radiated emission (300MHz – 1000MHz)              | $\pm 3.9\text{dB}$             |
| Radiated emission (1000MHz – 26GHz)               | $\pm 3.6\text{dB}$             |

## 7. Laboratory description

---

**7.1 Location:** ZACTA Technology Corporation Yonezawa Testing Center  
4149-7 Hachimanpara 5-chome Yonezawa-shi Yamagata 992-1128 Japan  
Phone: +81-238-28-2880 Fax: +81-238-28-2888

### 7.2 Facility filing information:

1) NVLAP accreditation: NVLAP Lab. code: 200306-0

2) FCC filing: Pursuant to Section 2.948 of the FCC rules.

| Site name   | Registration Number | Expiry Date       |
|---|---------------------|-------------------|
| Site 1, Site 2, Site3                                 | 91065               | November 16, 2008 |
| 3m Semi-anechoic chamber<br>10m Semi-anechoic chamber | 540072              | March 12, 2010    |

3) Industry Canada Oats site filing: Pursuant to RSS 212, Issue 1(Provisional).

| Site name                 | Sites on file:<br>Oats 3m/10m | Expiry Date      |
|---------------------------|-------------------------------|------------------|
| Site 2                    | 4224A-2                       | January 24, 2010 |
| Site 3                    | 4224A-3                       | January 24, 2010 |
| 3m Semi-anechoic chamber  | 4224A-4                       | January 24, 2010 |
| 10m Semi-anechoic chamber | 4224A-5                       | January 24, 2010 |

4) VCCI site filing: Pursuant to V-5/2006.04 VCCI regulations for registration of measurement facilities.

| Site name                 | Radiated emission<br>registration No. | Conducted emission<br>registration No. | Duration of registration |
|---------------------------|---------------------------------------|--|--------------------------|
| Site 1                    | R-136                                 | C-132                                  | November 16, 2008        |
| Site 2                    | R-137                                 | C-133                                  | November 16, 2008        |
| Site 3                    | R-138                                 | C-134                                  | November 16, 2008        |
| 10m Semi-anechoic chamber | R-2480                                | C-2722                                 | December 19, 2009        |
| 3m Semi-anechoic chamber  | R-2481                                | C-2723                                 | December 19, 2009        |
| Shielded room No.1        | -                                     | C-2724                                 | December 19, 2009        |

5) ETL SEMKO authorization:

Authorized as an EMC test laboratory.

6) TUV Rheinland authorization:

Authorized as an EMC test laboratory.

## 8. Test photographs

---

### *Transmitter Radiated Spurious Emissions*

[Horizontal Installation]



[Vertical Installation]

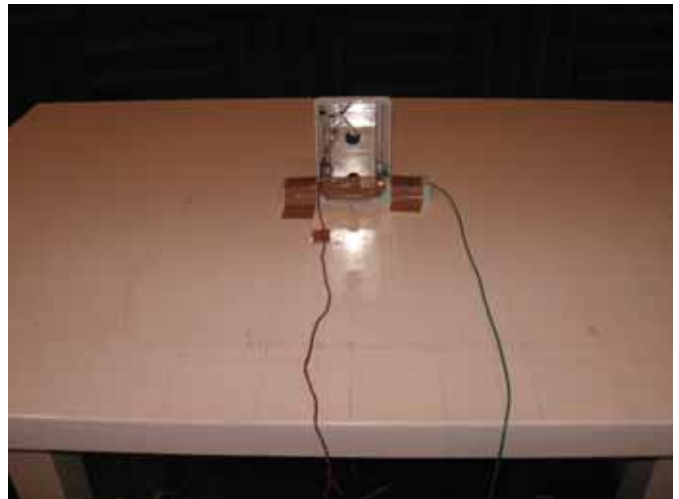

*Frequency Tolerance*



*AC power line Conducted Emissions*

