

Operational description

| | |
|---------------------|-----------------------------|
| <u>Product Name</u> | <u>ALV2 ENTRANCE READER</u> |
| <u>Model</u> | <u>ALV2 DCU-DP</u> |

Version 1.0

July 12, 2010

MIWA LOCK CO., LTD.

1. Outline of the ALV2 ENTRANCE READER

There are two states in this unit.

- (1) State of card waiting
- (2) State of card communication

(1) This unit radiates frequency of 13.56MHz. for 1ms at interval of 250ms to confirm the presence of the Mifare card. When this unit detects a card, it stops the radiating frequency of 13.56MHz..

(2) Once this unit detects a card, the unit starts to communicate on frequency of 13.56MHz.

(1) State of card waiting

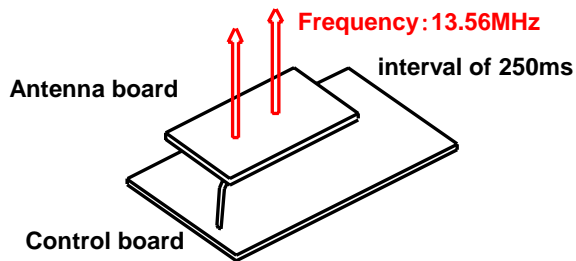

(2) State of card communication

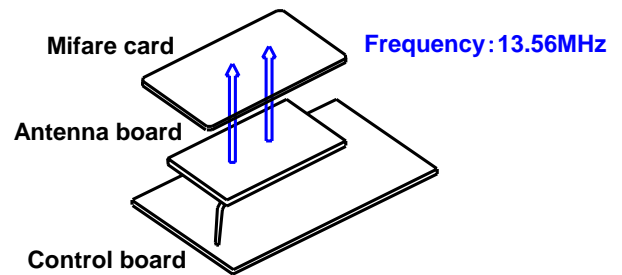

2. Device Structure

2.1. Block diagram1

The following shows functional block diagram for card lock control components.

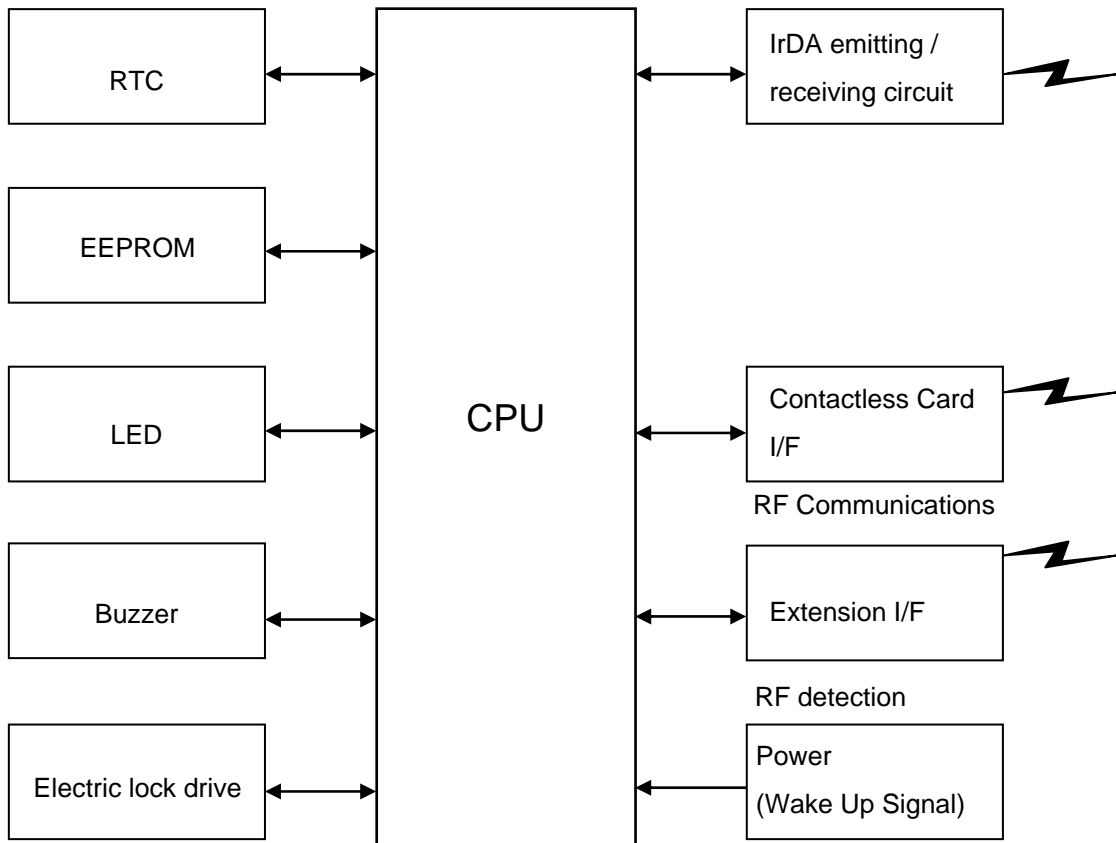

2.2. Block diagram2

Note: There are two RF antenna. One is for detection, the other is for communication. They do not work simultaneity.

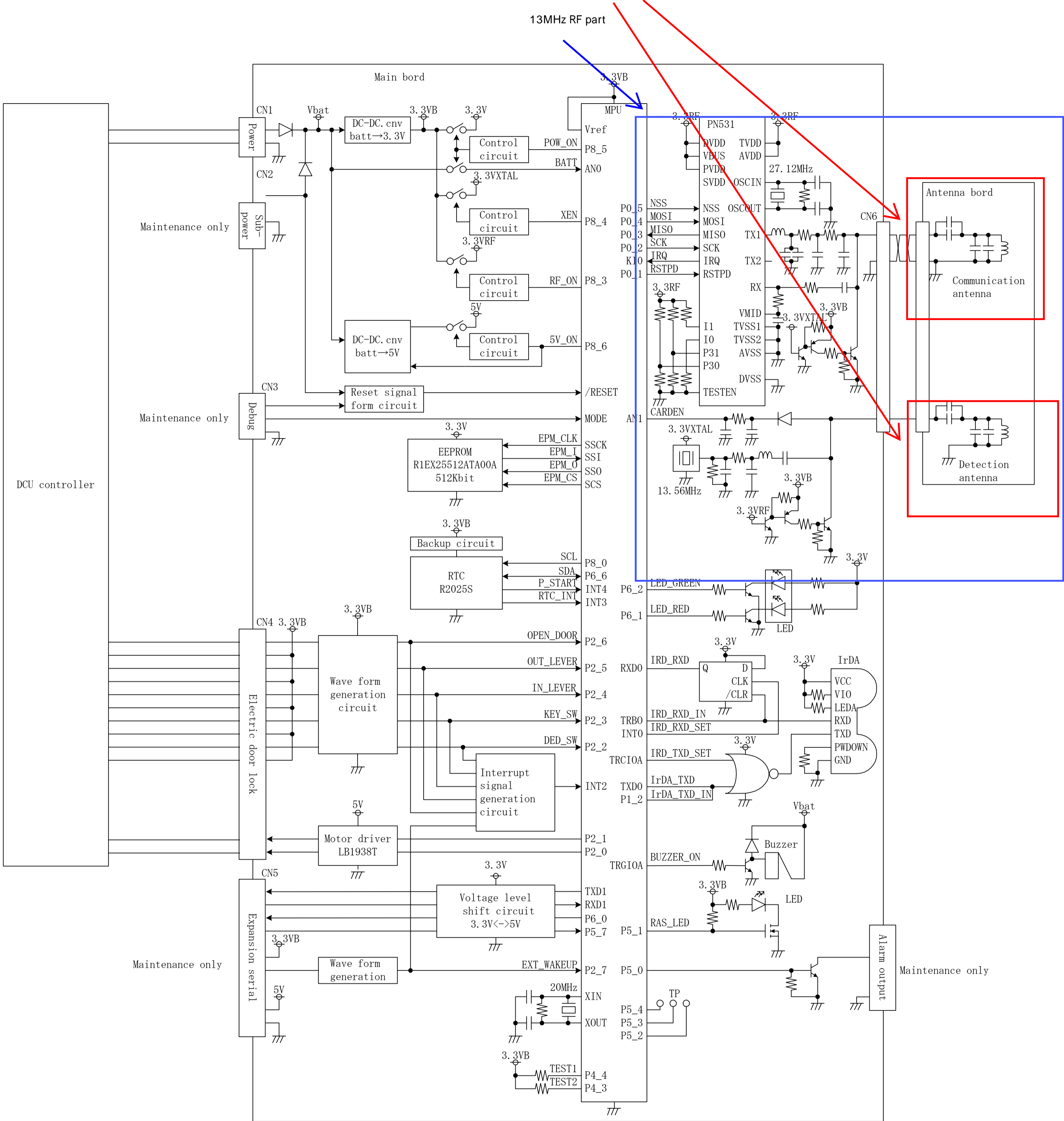

3. Hardware Configuration Diagram

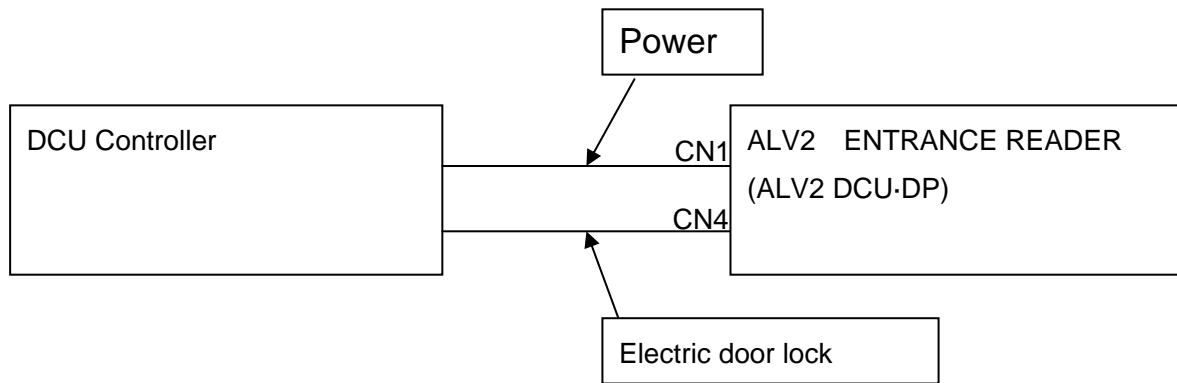

4.Other

- ※ Installation work is done by professional contractors.
- ※ This unit is 13.56MHz RF circuit independent.
- ※ RF circuits and RF communication circuits are not detected at the same time keep on moving.