

Global Product Compliance Laboratory
600-700 Mountain Avenue
Room 5B-108
Murray Hill, New Jersey 07974-0636 USA



TESTING
NVLAP LAB CODE: 100275-0

Title 47 Code of Federal Regulations Test Report

Regulation:
FCC Part 2 and 27

Client:
Nokia Mobile Networks

Product Evaluated:
AZHA AirScale RRH 4T4R B41 (AZHA)

Report Number:
TR-2019-0034-FCC2-27

Date Issued:
March 11, 2019

This report shall not be reproduced, in whole or in part without the approval of Nokia Global Product Compliance Laboratory. This report must not be used by the recipient to claim product endorsement by NVLAP or any other agency of the U.S. Government.

Table of Contents

1. SYSTEM INFORMATION AND REQUIREMENTS.....	4
1.1 INTRODUCTION.....	5
1.2 PURPOSE AND SCOPE.....	5
1.3 EUT DETAILS.....	5
1.4 REFERENCE DOCUMENTS, TEST SPECIFICATIONS & PROCEDURES.....	6
1.5 EXECUTIVE SUMMARY.....	8
1.6 TEST CONFIGURATION FOR ALL ANTENNA PORT MEASUREMENTS.....	8
2. FCC SECTION 2.1046 - RF POWER OUTPUT.....	9
2.1 RF POWER OUTPUT.....	9
3. FCC SECTION 2.1047 - MODULATION CHARACTERISTICS.....	12
3.1 MODULATION CHARACTERISTICS.....	12
4. FCC SECTION 2.1049 – OCCUPIED BANDWIDTH.....	13
4.1 OCCUPIED BANDWIDTH.....	13
4.2 OCCUPIED BANDWIDTH/ EDGE OF BAND EMISSIONS.....	17
5. FCC SECTION 2.1051 - SPURIOUS EMISSIONS AT TRANSMIT ANTENNA PORT.....	20
5.1 MEASUREMENT OF SPURIOUS EMISSIONS AT TRANSMIT ANTENNA PORT.....	20
6. FCC SECTION 2.1053.....	28
6.1 SECTION 2.1053 FIELD STRENGTH OF SPURIOUS EMISSIONS.....	28
6.2 FIELD STRENGTH OF SPURIOUS EMISSIONS - LIMITS.....	28
7. FREQUENCY STABILITY.....	29
8. NVLAP CERTIFICATE OF ACCREDITATION.....	41

Revisions

Date	Revision	Section	Change
3/11/2019	0		Initial Release

Nokia Global Product Compliance Laboratory represents to the client that testing was done in accordance with standard procedures as applicable, and that reported test results are accurate within generally accepted commercial ranges of accuracy in accordance with the scope of our NVLAP Accreditation. Nokia Global Product Compliance reports only apply to the specific samples tested. This report is the property of the client. This report shall not be reproduced except in full without the written approval of the Nokia Global Product Compliance Laboratory.

Nokia Global Product Compliance Laboratory is accredited with the US Department of Commerce National Institute of Standards and Technology's National Voluntary Laboratory Accreditation Program (NVLAP) for satisfactory compliance with criteria established in Title 15, Part 7 Code of Federal Regulations for offering test services for selected test methods in Electromagnetic Compatibility; Voluntary Control Council for Interference (VCCI), Japan; Australian Communications and Media Authority (ACMA).

Nokia Global Product Compliance Laboratory represents to the client that the laboratory's accreditation or any of its calibration or test reports in no way constitutes or implies product certification, approval, or endorsement by NVLAP, NIST, or any agency of the federal government.

Prepared By:

Signed:  3/11/2019
 Nilesch Patel
 Compliance Engineer

Approved By:

Signed:  3/11/2019
 Raymond Johnson
 Technical Manager

Reviewed By:

Signed:  3/11/2019
 Steve Gordon
 Compliance Engineer

1. System Information and Requirements

Equipment Under Test (EUT):	AZHA AirScale RRH 4T4R B41 (AZHA) FCCID: VBNAZHA-01
Serial Number:	6Q180516145
Cell Name / Number	GPCL Project Number: 2019-0034
Manufacturer:	NOKIA SOLUTIONS AND NETWORKS OY KARAPORTTI 3, FI-02610 ESPOO FINLAND
Applicant	NOKIA SOLUTIONS AND NETWORKS US LLC 6000 CONNECTION DRIVE IRVING, TEXAS 75039
Test Requirement(s):	Title 47 CFR Parts 2 and 27
Test Standards	<ul style="list-style-type: none"> Title 47 CFR Parts 2 and 27 KDB 971168 D01 Power Measurement License Digital Systems v03r01 April 9, 2018. KDB 662911 D01 Multiple Transmitter Output v02r01 Oct 2013
Measurement Procedure(s):	FCC-IC-OB - GPCL Occupied Bandwidth and Power Measurement Test Procedure 12-4-2017 FCC-IC-SE - GPCL Spurious Emissions Test Procedure 12-4-2017
Reference(s):	<ul style="list-style-type: none"> ANSI C63.26 (2015) ANSI C63.4 (2014)
Test Date(s):	Jan/Feb 2019
Test Performed By:	Nokia Global Product Compliance Laboratory 600-700 Mountain Ave. P.O. Box 636 Murray Hill, NJ 07974-0636
Nokia Global Product Compliance Laboratories is accredited by the National Voluntary Laboratory Accreditation Program (NVLAP®) for specific services, listed on the Scope of Accreditation, for: Electromagnetic Compatibility and Telecommunications. This laboratory is accredited in accordance with the recognized International Standard ISO/IEC 17025:2005. This accreditation demonstrates technical competence for a defined scope and the operation of a laboratory quality management system (refer to joint ISO-ILAC-IAF Communiqué dated January 2009). NVLAP LAB CODE: 100275-0.	
Product Engineer(s):	Ron Remy
Lead Engineer	Steve Gordon
Test Engineer (s):	Jaideep Yadav, Eugene Mitchell, Mike Soli
Test Results: The AZHA AirScale RRH 4T4R B41 (AZHA), <i>as tested</i> met the above listed requirements. Report copies and other information not contained in this report are held by either the product engineer or in an identified file at the Global Product Compliance Laboratory in New Providence, NJ.	

1.1 Introduction

This Conformity test report applies to the AZHA AirScale RRH 4T4R B41 (AZHA), hereinafter referred to as the Equipment Under Test (EUT).

1.2 Purpose and Scope

The purpose of this document is to provide the testing data required for qualifying the EUT in compliance with FCC Parts 2 and 27 measured in accordance with the procedures set out in Section 2.1033 (c) (14) of the Rules.

AirScale RRH 4T4R, B41, 80W, is a new Rel5.1 platform RRH. It provides a compact and cost-optimized site solution deployment at wall, pole, book and tower sites. It enables easy installation outdoors, close to antennas. It is also RAS compatible.

1.3 EUT Details

Parameter	Value
Operating Frequency Bands	2496 – 2690 MHz (3GPP Band 41)
Transmit and Receive Signal Bandwidths	80MHz
Number of Transmit and Receive Paths	4Tx/4Rx
Mean Output Power Per Power Amplifier	20W
Transmit Error Vector Magnitude	Comply with 3GPP TS 36.104 QPSK, 17.5% 16QAM, 12.5% 64QAM, 7.5% 256QAM, 3.5%
Receive Sensitivity	-105.6dBm
Adjacent Channel Power	ACLR > 45dB
Gigabit Serial Data Interface: Standard-Based Interface	CPRI: 3*9.8Gb/s rates; IQ Compression Supported
Maximum Fiber Length	20kM
VSWR Alarm Detection	User Programmable Alarm Thresholds

1.3.1 Test Requirements

Each required measurement is listed below:

47 CFR FCC Sections	Description of Tests	Test Required
2.1046	RF Power Output	Yes
2.1047	Modulation Characteristics	Yes
2.1049	(a) Occupied Bandwidth	Yes

	(b) Out-of-Band Emissions	
2.1051	Spurious Emissions at Antenna Terminals	Yes
2.1053	Field Strength of Spurious Radiation	Yes

1.4 Reference Documents, Test Specifications & Procedures

A list of the applicable documents is provided in Section 1.0.

1.4.1 Test Specifications

- Title 47 Code of Federal Regulations, Federal Communications Commission Part 2.
- Title 47 Code of Federal Regulations, Federal Communications Commission Part 27.
- ANSI C63.26, American National Standard for Compliance Testing of Transmitters Used in Licensed Radio Services

1.4.2 Procedures

1. FCC-IC-0B and FCC-IC-SE
2. ANSI C63.4 (2014) entitled: “American National Standard for Methods of Measurement of Radio-Noise Emissions from Low Voltage Electrical and Electronic Equipment in the Range of 9kHz to 40 GHz”, American National Standards Institute, Institute of Electrical and Electronic Engineers, Inc., New York, NY 10017-2394, USA.
3. FCC KDB 971168 D01 Power Measurement License Digital Systems v03r01 April 9, 2018.
 FCC KDB 662911 D01 Multiple Transmitter Output v02r01 Oct 2013

1.4.3 MEASUREMENT UNCERTAINTY

The results of the calculations to estimate uncertainties for the several test methods and standards are shown in the Table below. These are the worst-case values.

Worst-Case Estimated Measurement Uncertainties

Standard, Method or Procedure	Condition	Frequency MHz	Expanded Uncertainty (k=2)
a. Classical Emissions, (e.g., ANSI C63.4, CISPR 11, 14, 22, etc., using ESHS 30,	Conducted Emissions	0.009 - 30	±3.5 dB
	Radiated Emissions (AR-6 Semi-Anechoic Chamber)	30 MHz – 200MHz H 30 MHz – 200 MHz V 200 MHz – 1000 MHz H 200 MHz – 1000 MHz V 1 GHz - 18 GHz	±5.1 dB ±5.1 dB ±4.7 dB ±4.7 dB ±3.3 dB

Antenna Port Test	Signal Bandwidth	Frequency Range	Expanded Uncertainty (k=2), Amplitude
Occupied Bandwidth, Edge of Band, Conducted Spurious Emissions	10 Hz	9 kHz to 20 MHz	1.78 dB
	100 Hz	20 MHz to 1 GHz	
	10 kHz to 1 MHz	1 GHz to 10 GHz	
	1MHz	10 GHz to 40 GHz:	
RF Power	10 Hz to 20 MHz	50 MHz to 18 GHz	0.5 dB

1.5 Executive Summary

Requirement	Description	Result
47 CFR FCC Parts 2 and 27		
2.1046	RF Power Output Peak to Average Power Ratio	COMPLIES
2.1047	Modulation Characteristics	COMPLIES
2.1049	Occupied Bandwidth (a) Emissions Signal Bandwidth (b) Occupied Bandwidth/ Edge of Band Emissions	COMPLIES
2.1051	Spurious Emissions at Antenna Terminals	COMPLIES
2.1053	Field Strength of Spurious Radiation	COMPLIES

1. **COMPLIES** - Passed all applicable tests.
2. **N/A** – Not Applicable.
3. **NT** – Not Tested.

1.6 Test Configuration for all Antenna Port Measurements.

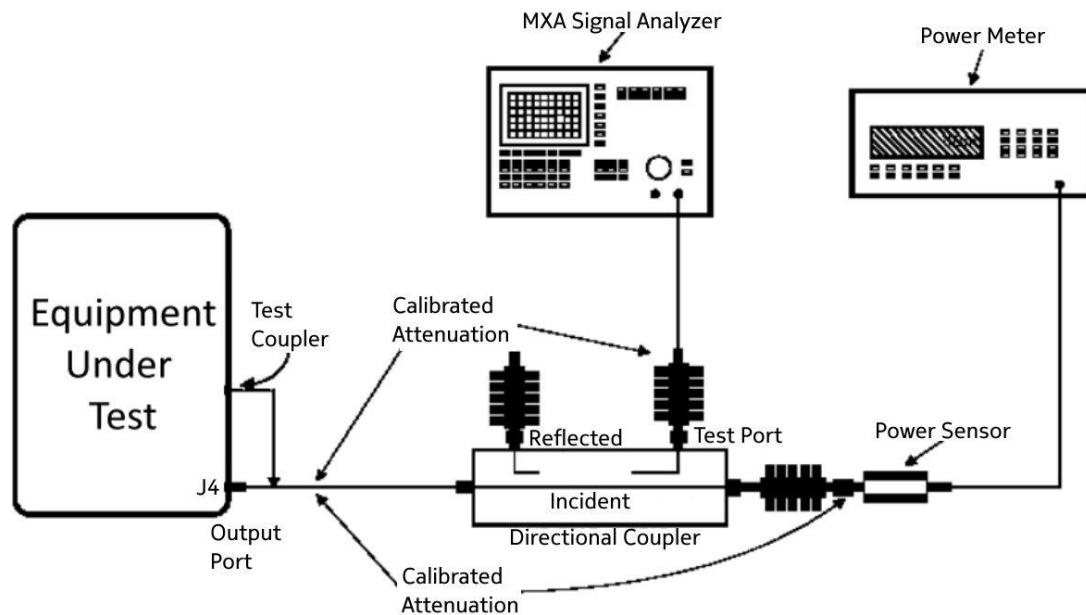

2. FCC Section 2.1046 - RF Power Output

2.1 RF Power Output

This test is a measurement of the total RF power level transmitted at the antenna-transmitting terminal. The product was configured for test as shown in section 1.6 above and allowed to warm up and stabilize per KDB 971168 D01 and ANSI C63.26.

Power measurements were made with an MXA Signal Analyzer.

Tabular Data – Channel RF Power

Channel Frequency MHz	Signal BW MHz	Modulation	Channel Power dBm
2506	20	64QAM	42.19
		256QAM	43.16
		QPSK + 16QAM	42.60
2593	20	64QAM	42.76
		256QAM	43.23
		QPSK + 16QAM	42.76
2680	20	64QAM	42.87
		256QAM	42.63
		QPSK + 16QAM	43.13
2573+2593	20+20 Contiguous	(QPSK+16QAM) + 64QAM	42.95
		64QAM + 256QAM	43.28
2660+2680	20+20 Contiguous	(QPSK+16QAM) + 64QAM	43.03
		64QAM + 256QAM	43.14
2506+2526	20+20 Contiguous	(QPSK+16QAM) + 64QAM	42.27
		64QAM + 256QAM	42.51
2593+2653	20+20 Non-Contiguous	(QPSK+16QAM) + 64QAM	43.09
		64QAM + 256QAM	43.17
2620+2680	20+20 Non-Contiguous	(QPSK+16QAM) + 64QAM	43.05
		64QAM + 256QAM	43.22
2506+2566	20+20 Non-Contiguous	(QPSK+16QAM) + 64QAM	42.92
		64QAM + 256QAM	43.01
2506+2526+2546	20+20+20 Contiguous	(QPSK+16QAM) + 64QAM + 256QAM	42.42
2573+2593+2613	20+20+20 Contiguous	(QPSK+16QAM) + 64QAM + 256QAM	43.09
2640+2660+2680	20+20+20 Contiguous	(QPSK+16QAM) + 64QAM + 256QAM	43.05
2506+2536+2566	20+20+20 Non-Contiguous	(QPSK+16QAM) + 64QAM + 256QAM	42.53
2620+2650+2680	20+20+20 Non-Contiguous	(QPSK+16QAM) + 64QAM + 256QAM	42.87
2620+2640+2660+2680	20+20+20+20	(QPSK+16QAM) + 64QAM + 256QAM +256QAM	42.46
2506+2526+2546+2566	20+20+20+20	(QPSK+16QAM) + 64QAM + 256QAM +256QAM	42.36
2573+2593+2613+2633	20+20+20+20	(QPSK+16QAM) + 64QAM + 256QAM +256QAM	42.96

NOKIA - Proprietary

Use Pursuant to Company Instructions.

2.1.1 Channel RF Power - Plots.

NOTE: Only a sample of the plots are used in this report. The full suite of raw data resides at the MH, New Jersey location.

Ch_Power_TM3.1_1C_20MBW_2506_TX1

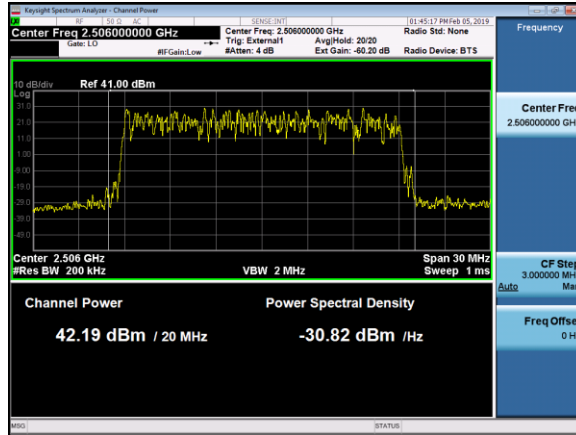

Ch_Power_TM3.1 TM3.1a_2C_20+20MBW_2573_2593_TX1

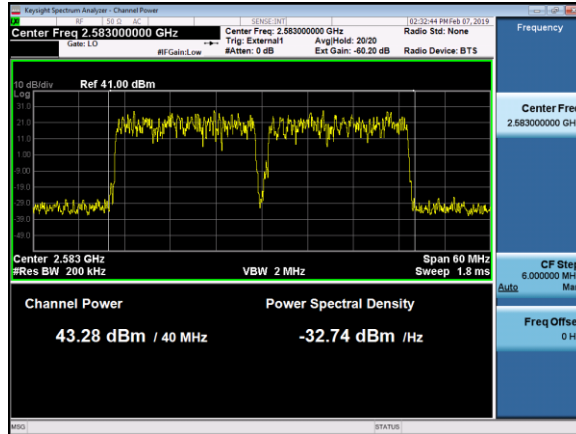

Ch_Power_TM3.1 TM3.1a_2C_20+20MBW_2593_2653_TX1

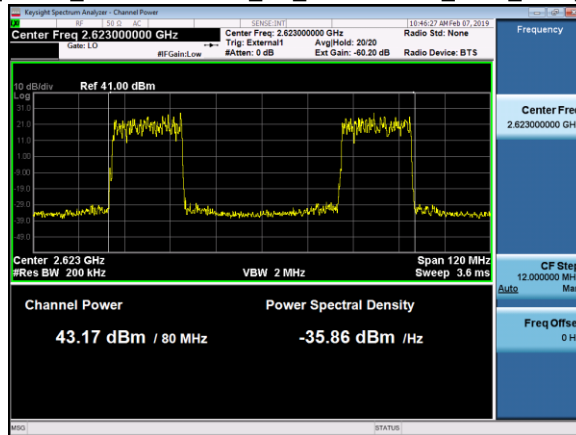

Ch_Power_TM3.2 TM3.1 TM3.1a_3C_20+20+20MBW_2506_2526_2546_TX1

NOKIA - Proprietary
Use Pursuant to Company Instructions.

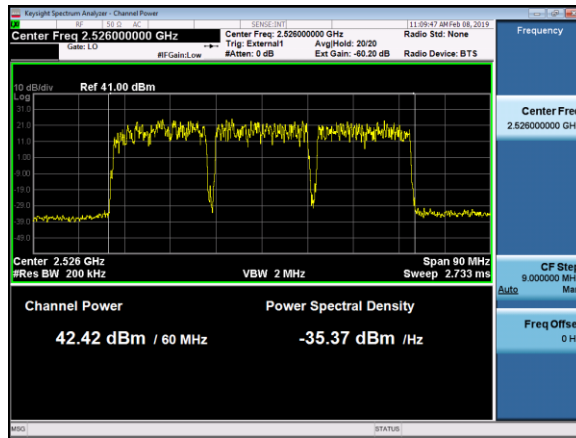

Ch_Power_TM3.2 TM3.1 TM3.1a_3C_20+20+20MBW_2506_2536_2566_TX1

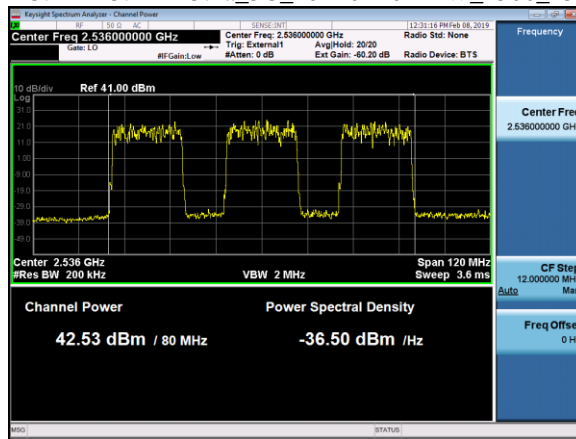

Ch_Power_TM3.2 TM3.1 TM3.1a TM3.1a_4C_20+20+20+20MBW_2620_2640_2660_2680_TX1

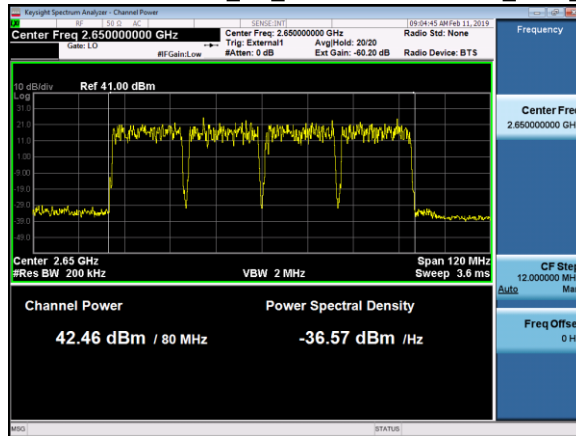

3. FCC Section 2.1047 - Modulation Characteristics

3.1 Modulation Characteristics

The RF signal at the antenna port was demodulated and verified for correctness of the modulation signal used before each test was performed. For these products the operation with QPSK, 16QAM, 64QAM and 256QAM modulation was evaluated and verified to demonstrate proper operation before testing.

3.1.1 Modulation Characteristics – Plots.

NOTE: Only a sample of the plots are used in this report. The full suite of raw data resides at the MH, New Jersey location.

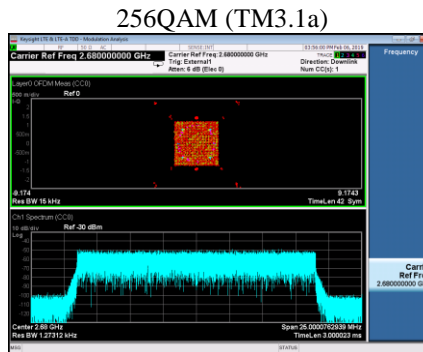
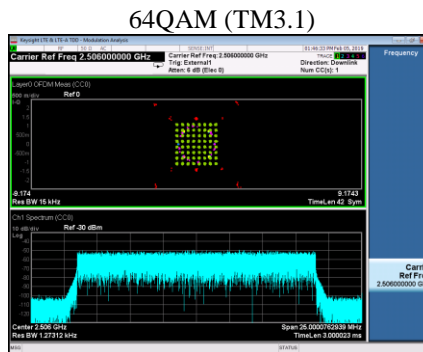
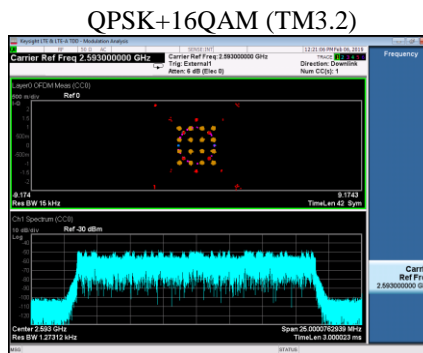

4. FCC Section 2.1049 – Occupied Bandwidth

4.1 Occupied Bandwidth

In 47CFR 2.1049 the FCC requires:

“The occupied bandwidth, that is the frequency bandwidth such that, below its lower and above its upper frequency limits, the mean powers radiated are each equal to 0.5 percent of the total mean power radiated by a given emission shall be measured under the following conditions as applicable.”

This required measurement is the 99% Occupied Bandwidth, also called the designated signal bandwidth and needs to be within the parameters of the products specified emissions designator.

During these measurements it is customary to evaluate the Edge of Band emissions at block/band edges.

The transmitted signal occupied bandwidth was measured using a Keysight MXA Signal Analyzer. All emissions were within the parameters as required.

Tabular Data – Occupied Bandwidth

Channel Frequency MHz	Signal BW MHz	Modulation	Occupied BW MHz
2506	20	64QAM	17.734
		256QAM	18.012
		QPSK + 16QAM	17.889
2593	20	64QAM	17.730
		256QAM	18.015
		QPSK + 16QAM	17.885
2680	20	64QAM	17.729
		256QAM	18.017
		QPSK + 16QAM	17.885
2573+2593	20+20 Contiguous	(QPSK+16QAM) + 64QAM	37.779
		64QAM + 256QAM	37.563
2660+2680	20+20 Contiguous	(QPSK+16QAM) + 64QAM	37.779
		64QAM + 256QAM	37.552
2506+2526	20+20 Contiguous	(QPSK+16QAM) + 64QAM	37.758
		64QAM+256QAM	37.547
2593+2653	20+20 Non-Contiguous	(QPSK+16QAM) + 64QAM	17.883 + 17.816
		64QAM + 256QAM	17.725 + 17.844
2620+2680	20+20 Non-Contiguous	(QPSK+16QAM) + 64QAM	17.892 + 17.849
		64QAM + 256QAM	17.728 + 17.846
2506+2566	20+20 Non-Contiguous	(QPSK+16QAM) + 64QAM	17.883 + 17.810
		64QAM + 256QAM	17.723 + 17.837
2506+2526+2546	20+20+20 Contiguous	(QPSK+16QAM) + 64QAM + 256QAM	57.619
2573+2593+2613	20+20+20 Contiguous	(QPSK+16QAM) + 64QAM + 256QAM	57.644
2640+2660+2680	20+20+20 Contiguous	(QPSK+16QAM) + 64QAM + 256QAM	57.641
2506+2536+2566	20+20+20 Non-Contiguous	(QPSK+16QAM) + 64QAM + 256QAM	17.889 + 17.830 + 17.609
2620+2650+2680	20+20+20 Non-Contiguous	(QPSK+16QAM) + 64QAM + 256QAM	17.898 + 17.818 + 17.622
2620+2640+2660+2680	20+20+20+20	(QPSK+16QAM) + 64QAM + 256QAM +256QAM	77.232
2506+2526+2546+2566	20+20+20+20	(QPSK+16QAM) + 64QAM + 256QAM +256QAM	77.199
2573+2593+2613+2633	20+20+20+20	64QAM	77.260

4.1.1 Occupied Bandwidth – Plots.

NOTE: Only a sample of the plots are used in this report. The full suite of raw data resides at the MH, New Jersey location.

OBW_TM3.1_1C_20MBW_2506_TX1

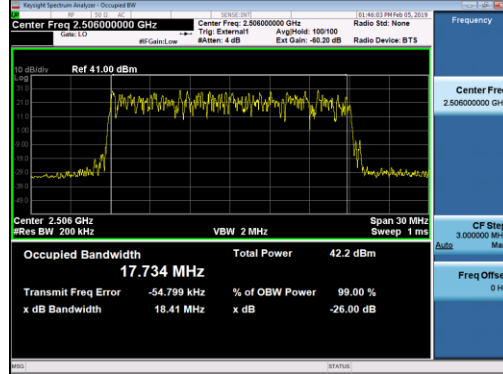

OBW_TM3.1 TM3.1a_2C_20+20MBW_2573_2593_TX1_Contiguous

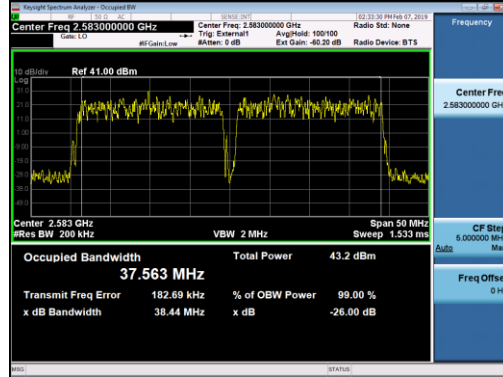

OBW_TM3.1 TM3.1a_2C_20+20MBW_2593_2653_TX1_Non-Contiguous

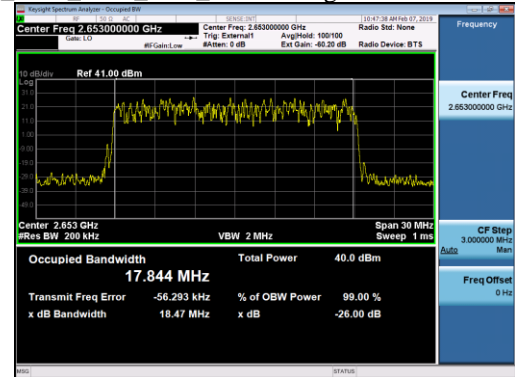
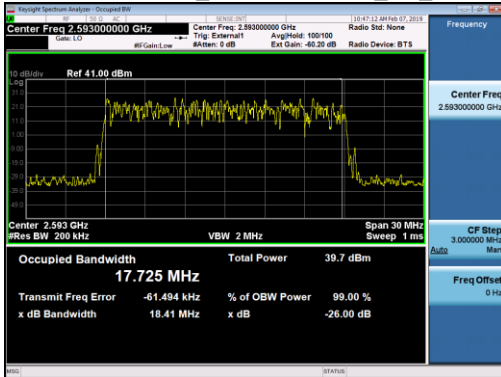

OBW_TM3.2 TM3.1 TM3.1a 3C_20+20+20MBW_2506_2526_2546_TX1_ Contiguous

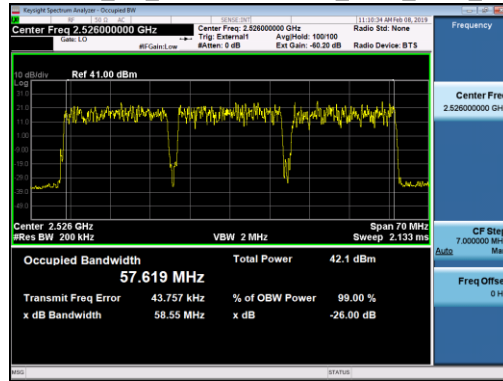

OBW_TM3.2 TM3.1 TM3.1a 3C_20+20+20MBW_2506_2536_2566_TX1_ Non-Contiguous

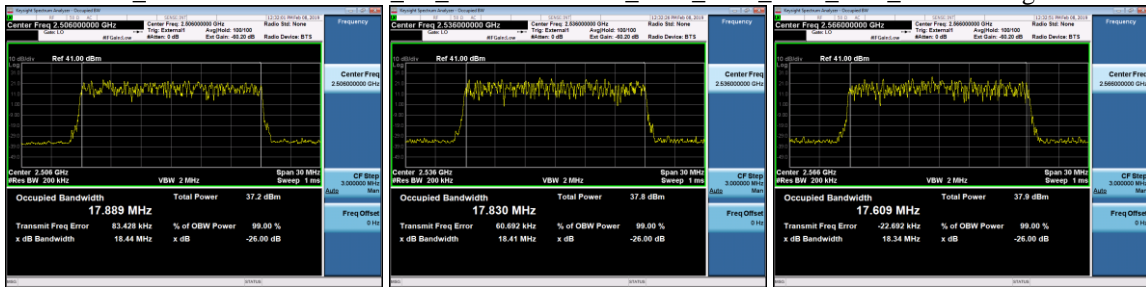

OBW_TM3.2 TM3.1 TM3.1a TM3.1a 4C_20+20+20+20MBW_2620_2640_2660_2680_TX1_ Contiguous

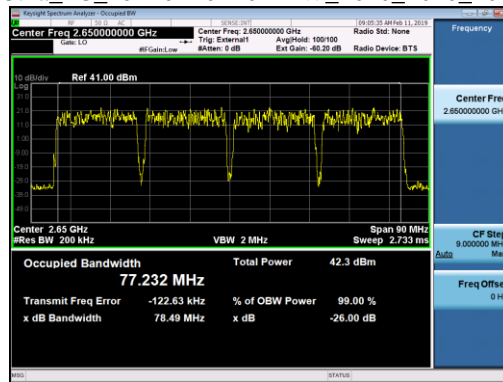

4.2 Occupied Bandwidth/ Edge of band Emissions

The Edge of Band emissions of the EUT at the external antenna connector (EAC) were measured using a Keysight MXA Signal Analyzer. The RF power level was continuously measured using a RF broadband power meter. The RF output from the EAC port to signal analyzer was reduced (to an amplitude usable by the signal analyzer) by using a calibrated attenuator and test coupler. The path attenuation was offset on the display and the signal for the carrier was adjusted to the corrected RF power level for the resolution bandwidth used for the transmit signal. All mask values were adjusted based upon the designated signal bandwidth and measurement bandwidths. The Top of Mask corresponds to the set rated power level as confirmed by the RF power meter.

4.2.1 Occupied Bandwidth Results.

The Occupied Bandwidth was measured for all three modulations, at each signal bandwidth and at left center and right side of band. The mask on the plots meet the Block Edge requirements as specified in 47CFR 27.53.

All of the measurements met the requirements of Part 27.53 when measured per Part 2.1049.

4.2.2 Edge of band Emissions - Plots.

NOTE: Only a sample of the plots are used in this report. The full suite of raw data resides at the MH, New Jersey location.

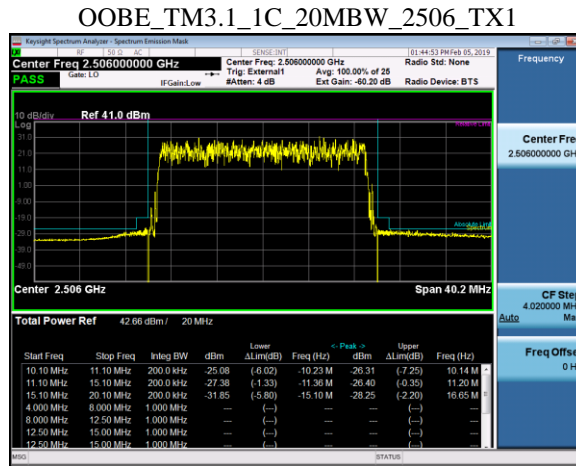

OOBE_TM3.1 TM3.1a_2C_20+20MBW_2573_2593_TX1

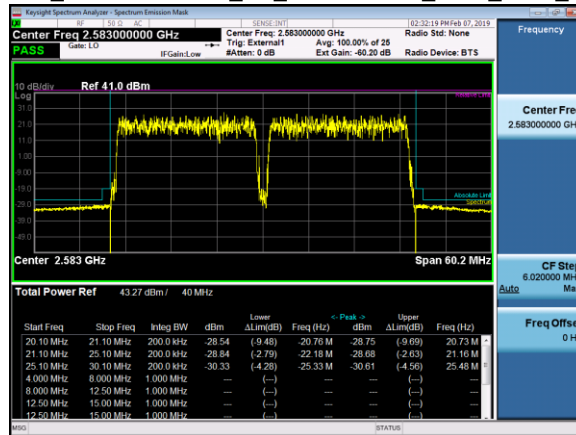

OOBE_TM3.1 TM3.1a_2C_20+20MBW_2593_2653_TX1

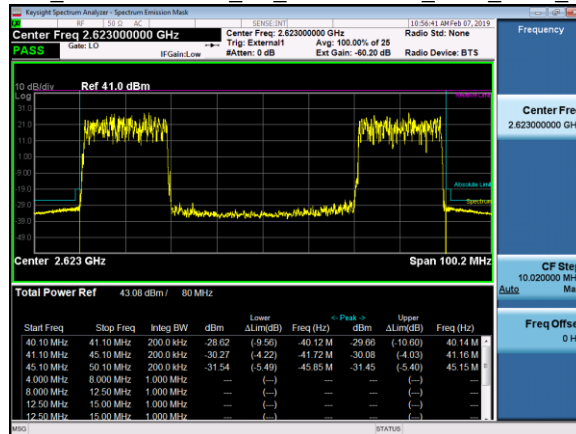

OOBE_TM3.2 TM3.1 TM3.1a_3C_20+20+20MBW_2506_2526_2546_TX1

NOKIA - Proprietary
Use Pursuant to Company Instructions.

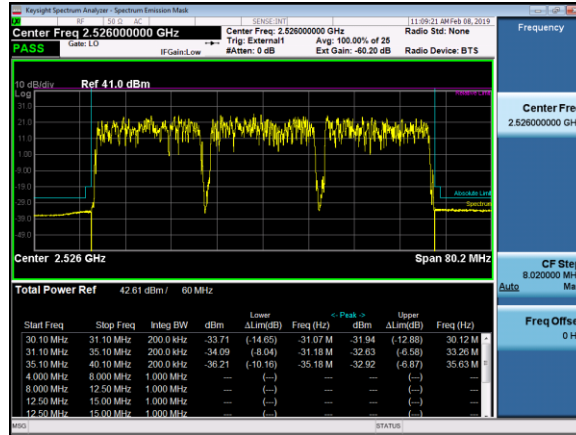

OOBE_TM3.2 TM3.1 TM3.1a_3C_20+20+20MBW_2506_2536_2566_TX1

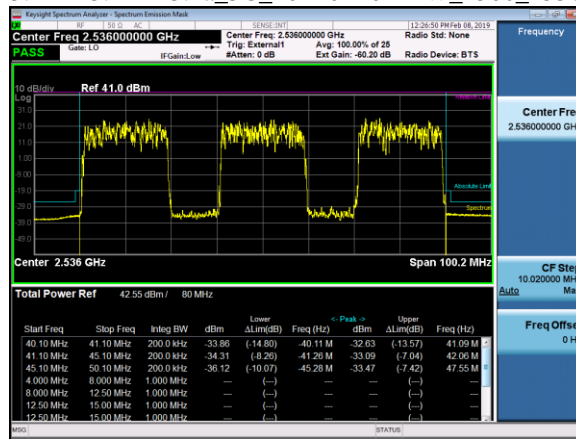

OOBE_TM3.2 TM3.1 TM3.1a TM3.1a_4C_20+20+20+20MBW_2620_2640_2660_2680_TX1

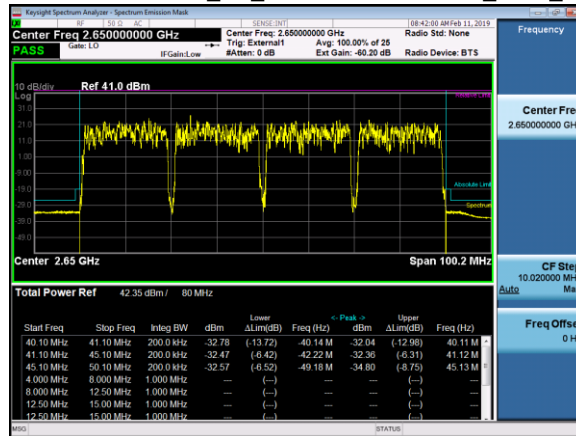

5. FCC Section 2.1051 - Spurious Emissions at Transmit Antenna Port

5.1 Measurement of Spurious Emissions at Transmit Antenna Port

Spurious Emissions at the transmit-antenna terminals were investigated over the frequency range of 10 MHz to beyond the 10th harmonic of the specific transmit band. For this band of operation, the measurements were performed up to 27GHz. Measurements were made using a Keysight MXA Signal Analyzer. The RF output from the transmitter was reduced (to an amplitude usable by the receivers) using calibrated attenuators. The RF power level was continuously monitored via a coupled RF Power Meter.

The required emission limitation is specified as appropriate in 27.53. The measured spurious emission levels were plotted for the frequency range as specified in 2.1057. There were no reportable emissions. Data below documents performance up to 27 GHz.

5.1.1 Plots – Spurious Emissions at Tx Port

NOTE: Only a sample of the plots are used in this report. The full suite of raw data resides at the MH, New Jersey location.

Spurious_TM3.1_1C_20MBW_2506_TX1

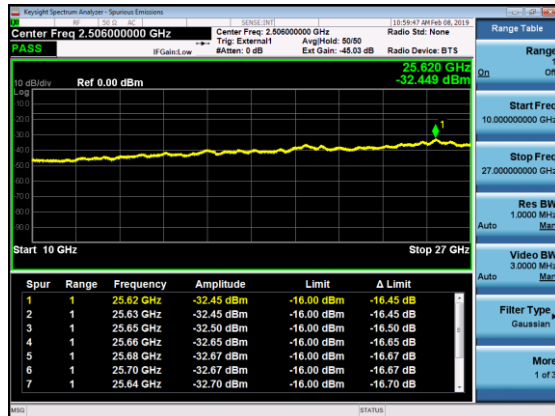
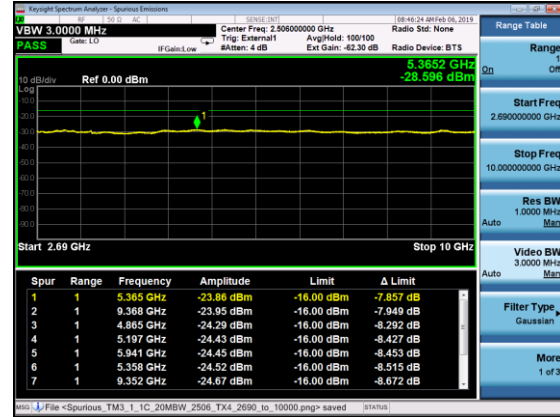
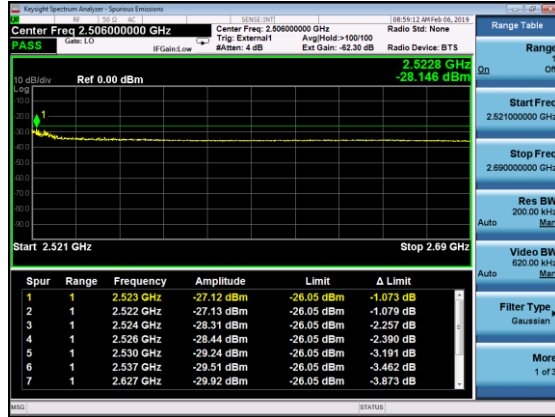
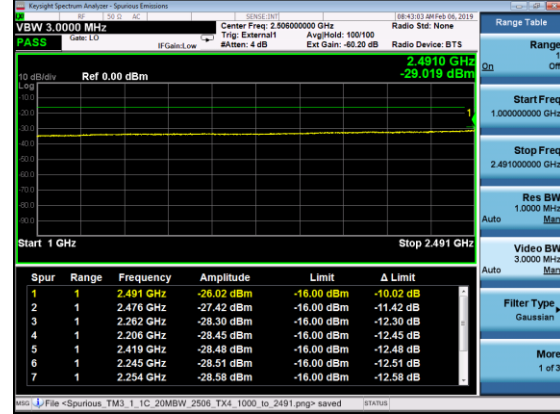

Spurious_TM3.1 TM3.1a_2C_20+20MBW_2573_2593_TX1_Contiguous

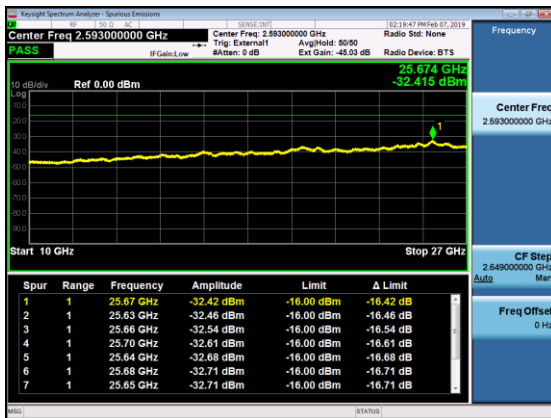
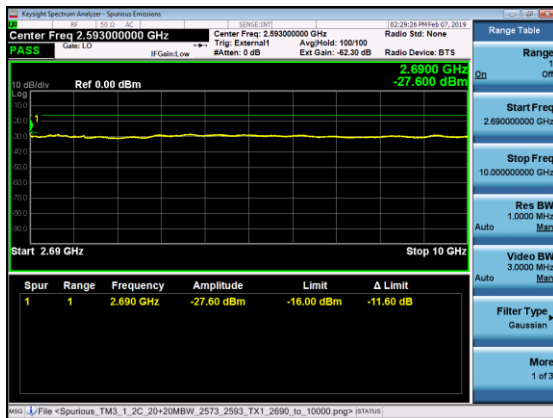
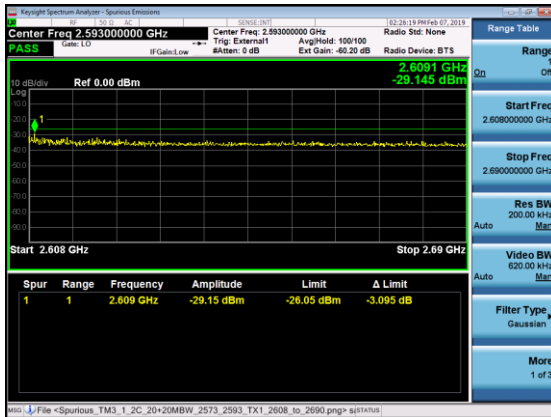
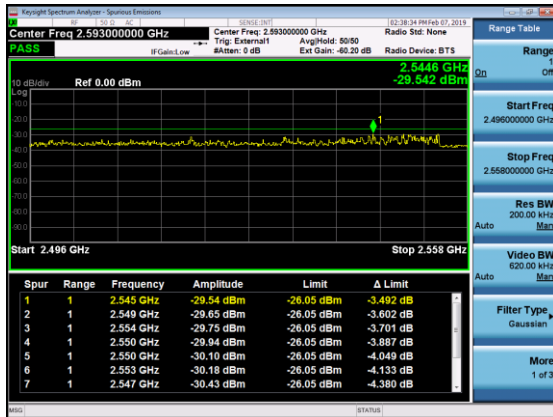
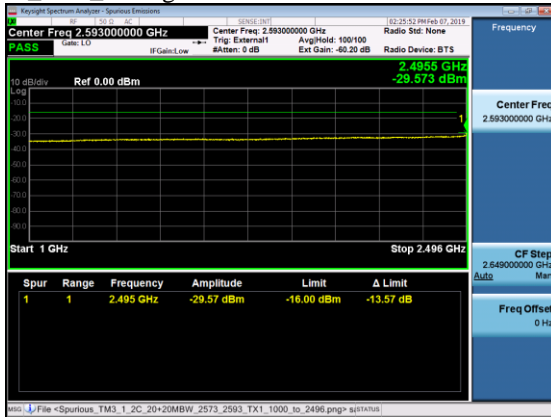

Spurious_TM3.1 TM3.1a_2C_20+20MBW_2593_2653_TX1_Non-Contiguous

NOKIA - Proprietary
 Use Pursuant to Company Instructions.

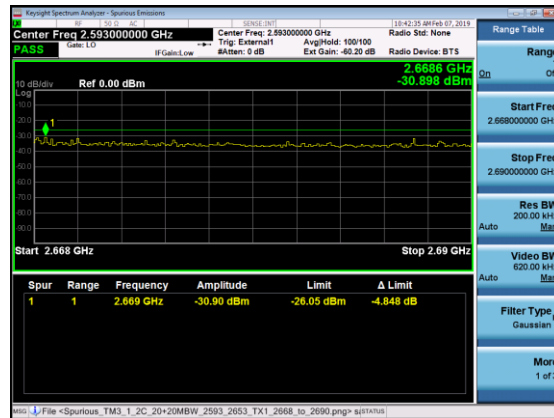
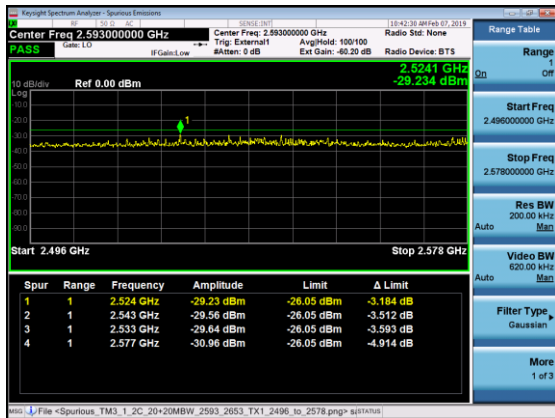

NOKIA - Proprietary
Use Pursuant to Company Instructions.

Spurious_TM3.2_TM3.1_TM3.1a_3C_20+20+20MBW_2506_2526_2546_TX1_Contiguous

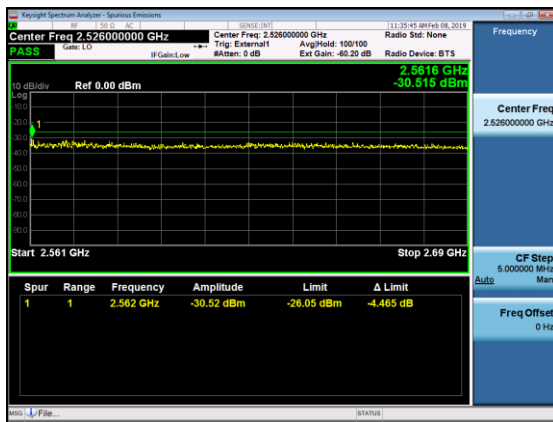
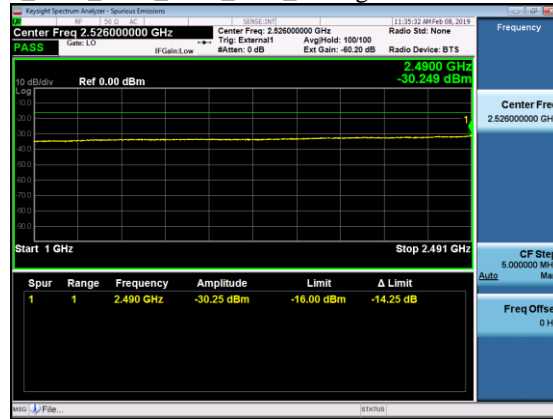

NOKIA - Proprietary
Use Pursuant to Company Instructions.

Spurious_TM3.2 TM3.1_3.1a_3C_20+20+20MBW_2620_2650_2680_TX1_Non-Contiguous

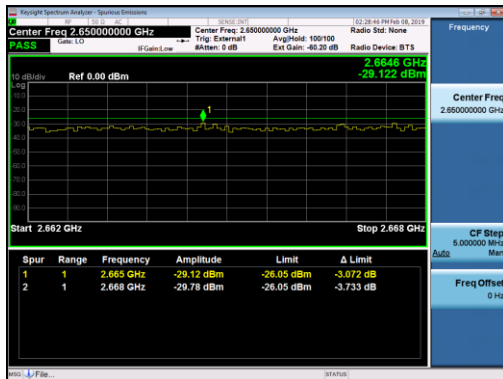
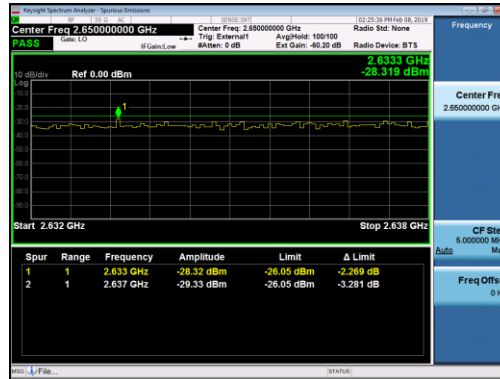
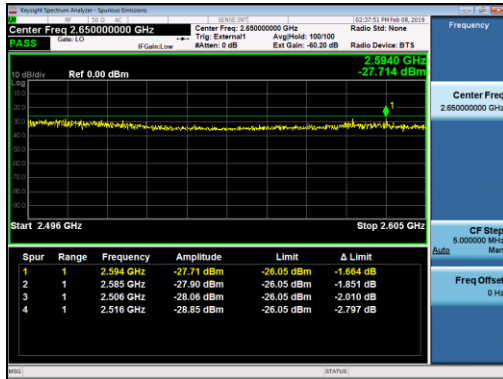
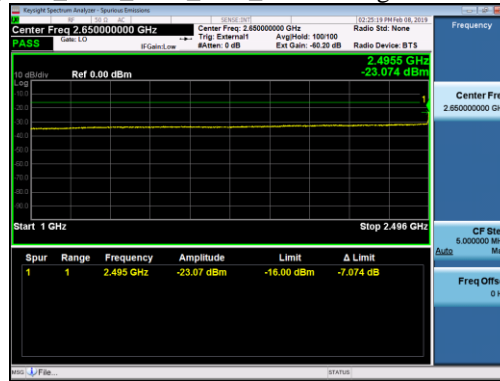

Spurious_TM3.2 TM3.1 TM3.1a TM3.1a_4C_20+20+20+20MBW_2573_2593_2613_2633_TX1

NOKIA - Proprietary
Use Pursuant to Company Instructions.

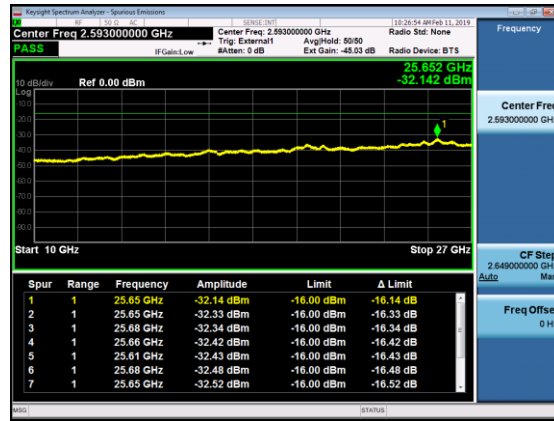
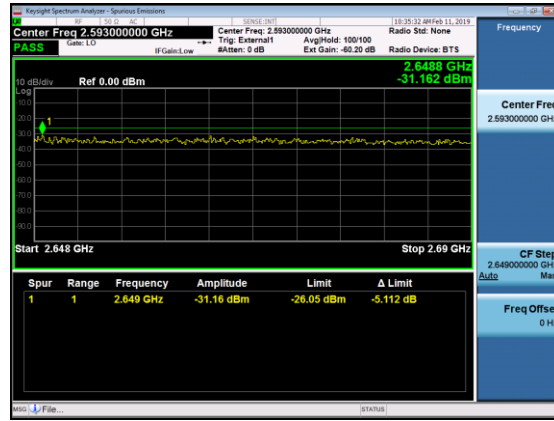
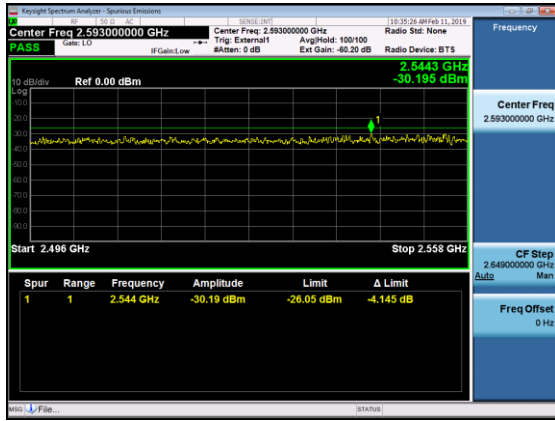
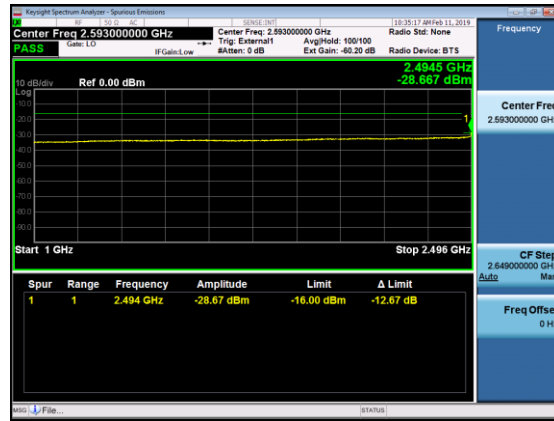

Test Equipment

Asset ID	Manufacturer	Type	Description	Model	Serial	Calibration Date	Calibration Due	Calibration Type	Status
E1251	Aeroflex	Attenuator	30dB 150W DC-18GHz Attenuator	66-30-33	BV1667			Calibration Not Required, Must Be Verified	Active
E831	Agilent Technologies	MXA Signal Analyzer	20Hz-26.5GHz	N9020A	MY48011791	2018-02-15	2020-02-15	Requires Calibration	Active
E1208	RLC Electronics Inc	High Pass Filter	2.5Ghz to 26Ghz High Pass Filter	F-19391	1440-001			Calibration Not Required, Must Be Verified	Active
E820	Weinschel	Attenuator	10 dB , 50 Watt	47-10-34	BX8022	2018-09-05	2020-09-05	Requires Calibration	Active
E1005	Weinschel	Attenuator	20 dB DC-18GHz 25W	46-20-34-LIM	BN3127				Active
	UTIFLEX MICRO-COAX	Cable	UFB142A-0-0720-2G0200/A. MFR65639 227883-001	142A Series 503609-G				Pathloss verified with attenuators	

6. FCC Section 2.1053

6.1 Section 2.1053 Field Strength of Spurious Emissions

Field strength measurements of radiated spurious emissions were made in 3m Semi-Anechoic Chambers the of Global Product Compliance Laboratories of Nokia Bell Labs in Murray Hill NJ. A complete description and full measurement data for the site is on file with the Commission (FCC File 515091).

The spectrum from 30 MHz to beyond the tenth harmonic of the carrier, 27 GHz, was searched for spurious radiation. Measurements were made using both horizontally and vertically polarized broadband antennas. Per FCC regulations, the comparison of out of band spurious emissions directly to the limit is appropriately made using the substitution method. However, when the emissions are more than 20 dB below the specification limit, the use of field strength measurements for compliance determination is acceptable and those emissions are considered not reportable (Section 2.1053 and the FCC Interpretive database for 2.1053). For this case the evaluation of acceptable radiated field strength is as follows.

6.2 Field Strength of Spurious Emissions - Limits

Sections 2.1053 and 27.53 contain the requirements for the levels of spurious radiation as a function of the level of the unmodulated carrier. The reference level for the unmodulated carrier is calculated as the field produced by an ideal dipole excited by the transmitter output power according to the following relation taken from Reference Data for Radio Engineers, page 676, 4th edition, IT&T Corp.

$$E = [(30 \cdot P)^{1/2}] / R$$

$$20 \log (E \cdot 10^6) - (43 + 10 \log P) = 82.23 \text{ dB}\mu\text{V}/\text{meter}$$

Where:

E = Field Intensity in Volts/meter

P = Transmitted Power in Watts

R = Measurement distance in meters = 3 m

The Part 27 Limit is 82.23 dB μ V/m at 3m and 91.77 dB μ V/m at 1m

The Part 27 non-report level is 62.23 dB μ V/m at 3m.

The calculated emission levels were found by:

$$\text{Measured level (dB}\mu\text{V)} + \text{Cable Loss(dB)} + \text{Antenna Factor(dB)} = \text{Field Strength (dB}\mu\text{V/m)}$$

RESULTS:

For compliance with 47CFR Parts 2 and 27, the field strength of any spurious radiation, measured at 3m, is required to be less than 82.23 dB μ V/meter (82.23 @ 3m). Emissions equal to or less than 62.23 dB μ V/meter at 3m are not reportable and may be verified using field strength measurements and broadband antennas. Over the out of band spectrum investigated from 30 MHz to beyond the tenth harmonic of the carrier (up to 27GHz), no reportable spurious emissions were detected.

7. Frequency Stability

Frequency Block Tested: PRI20184170 - AZHA AirScale RRH (CF = 2593MHz)

- (a) Set the power supply to nominal Voltage. (b) Record the frequency at ~25°C. (c) Raise EUT operating temperature to 50°C. (d) Record the frequency difference. (e) Repeat step (d) at each 10°C step down to -30°C. Result will be 10 readings and take temperature readings to establish thermal stability at each point.

Baseline Measurement at +25°C

Transmit Frequency Deviation at +25°C at 100% of Nominal Voltage, -48VDC	
Time (minutes)	Transmit Carrier Deviation (Hz)
0	2.134
0.5	0.140
1.0	6.135
1.5	2.016
2.0	0.258
2.5	0.211
3.0	4.115
FCC SPECIFICATION	±2593 MHz (±0.05ppm) ±0.05ppm = ±129.65 Hz
FCC RESULT	PASS

Transmit Frequency Deviation at +50°C at 100% of Nominal Voltage, -48VDC	
Time (minutes)	Transmit Carrier Deviation (Hz)
0	4.003
0.5	1.709
1.0	3.692
1.5	2.045
2.0	6.859
2.5	4.143
3.0	3.059
FCC SPECIFICATION	±2593 MHz (±0.05ppm) ±0.05ppm = ±129.65 Hz
FCC RESULT	PASS

Transmit Frequency Deviation at +40°C at 100% of Nominal Voltage, -48VDC	
Time (minutes)	Transmit Carrier Deviation (Hz)
0	1.161
0.5	1.690
1.0	0.883
1.5	2.206
2.0	5.227
2.5	4.409

3.0	2.984
FCC SPECIFICATION	±2593 MHz (±0.05ppm) ±0.05ppm = ±129.65 Hz
FCC RESULT	PASS

Transmit Frequency Deviation at +30°C at 100% of Nominal Voltage, -48VDC	
Time (minutes)	Transmit Carrier Deviation (Hz)
0	1.372
0.5	4.107
1.0	5.291
1.5	3.574
2.0	7.913
2.5	0.476
3.0	4.197
FCC SPECIFICATION	±2593 MHz (±0.05ppm) ±0.05ppm = ±129.65 Hz
FCC RESULT	PASS

Transmit Frequency Deviation at +20°C at 100% of Nominal Voltage, -48VDC	
Time (minutes)	Transmit Carrier Deviation (Hz)
0	3.192
0.5	4.577
1.0	1.759
1.5	6.411
2.0	3.827
2.5	1.374
3.0	8.063
FCC SPECIFICATION	±2593 MHz (±0.05ppm) ±0.05ppm = ±129.65 Hz
FCC RESULT	PASS

Transmit Frequency Deviation at +10°C at 100% of Nominal Voltage, -48VDC	
Time (minutes)	Transmit Carrier Deviation (Hz)
0	3.411
0.5	1.017
1.0	5.816
1.5	3.930
2.0	1.117
2.5	7.771
3.0	4.497
FCC SPECIFICATION	±2593 MHz (±0.05ppm) ±0.05ppm = ±129.65 Hz
FCC RESULT	PASS

Transmit Frequency Deviation at 0°C at 100% of Nominal Voltage, -48VDC	
Time (minutes)	Transmit Carrier Deviation (Hz)
0	5.993
0.5	2.411
1.0	3.405
1.5	6.107
2.0	2.774
2.5	1.736
3.0	4.634
FCC SPECIFICATION	±2593 MHz (±0.05ppm) ±0.05ppm = ±129.65 Hz
FCC RESULT	PASS

Transmit Frequency Deviation at -10°C at 100% of Nominal Voltage, -48VDC	
Time (minutes)	Transmit Carrier Deviation (Hz)
0	4.975
0.5	1.777
1.0	6.425
1.5	11.128
2.0	6.080
2.5	7.592
3.0	5.638
FCC SPECIFICATION	±2593 MHz (±0.05ppm) ±0.05ppm = ±129.65 Hz
FCC RESULT	PASS

Transmit Frequency Deviation at -20°C at 100% of Nominal Voltage, -48VDC	
Time (minutes)	Transmit Carrier Deviation (Hz)
0	5.669
0.5	3.486
1.0	3.370
1.5	4.362
2.0	9.097
2.5	2.931
3.0	3.827
FCC SPECIFICATION	±2593 MHz (±0.05ppm) ±0.05ppm = ±129.65 Hz
FCC RESULT	PASS

Transmit Frequency Deviation at -30°C at 100% of Nominal Voltage, -48VDC	
Time (minutes)	Transmit Carrier Deviation (Hz)
0	1.605
0.5	5.910
1.0	7.093
1.5	3.704
2.0	1.642
2.5	5.257
3.0	2.480
FCC SPECIFICATION	±2593 MHz (±0.05ppm) ±0.05ppm = ±129.65 Hz
FCC RESULT	PASS

Upon return to +25°C.

- At ambient, vary voltage to +15% and -15% of nominal and record frequency difference. Result will be 12 readings for each voltage (nominal, ~+ 3%, ~+6%, ~+9, ~+12%, +15%, and nominal, ~- 3%, ~-6%, ~-9, ~-12%, -15%).

Transmit Frequency Deviation at +25°C at 100% of Nominal Voltage, -48VDC	
Time (minutes)	Transmit Carrier Deviation (Hz)
0	3.617
0.5	5.109
1.0	2.345
1.5	1.612
2.0	4.324
2.5	7.005
3.0	1.972
FCC SPECIFICATION	±2593 MHz (±0.05ppm) ±0.05ppm = ±129.65 Hz
FCC RESULT	PASS

Transmit Frequency Deviation at +25°C at 103% of Nominal Voltage, -49.44VDC	
Time (minutes)	Transmit Carrier Deviation (Hz)
0	4.219
0.5	1.833
1.0	5.162
1.5	3.187
2.0	8.564
2.5	1.436
3.0	4.612
FCC SPECIFICATION	±2593 MHz (±0.05ppm) ±0.05ppm = ±129.65 Hz
FCC RESULT	PASS

Transmit Frequency Deviation at +25°C at 106% of Nominal Voltage, -50.88VDC	
Time (minutes)	Transmit Carrier Deviation (Hz)
0	4.087
0.5	2.401
1.0	3.133
1.5	6.717
2.0	1.974
2.5	4.955
3.0	2.304
FCC SPECIFICATION	±2593 MHz (±0.05ppm) ±0.05ppm = ±129.65 Hz
FCC RESULT	PASS

Transmit Frequency Deviation at +25°C at 109% of Nominal Voltage, -52.32VDC	
Time (minutes)	Transmit Carrier Deviation (Hz)
0	1.130
0.5	5.039
1.0	2.417
1.5	4.912
2.0	7.200
2.5	9.268
3.0	1.735
FCC SPECIFICATION	±2593 MHz (±0.05ppm) ±0.05ppm = ±129.65 Hz
FCC RESULT	PASS

Transmit Frequency Deviation at +25°C at 112% of Nominal Voltage, -53.76VDC	
Time (minutes)	Transmit Carrier Deviation (Hz)
0	5.546
0.5	1.601
1.0	3.077
1.5	4.327
2.0	6.091
2.5	8.283
3.0	2.916
FCC SPECIFICATION	±2593 MHz (±0.05ppm) ±0.05ppm = ±129.65 Hz
FCC RESULT	PASS

Transmit Frequency Deviation at +25°C at 115% of Nominal Voltage, -55.20VDC	
Time (minutes)	Transmit Carrier Deviation (Hz)
0	3.755
0.5	1.456
1.0	7.832
1.5	1.097
2.0	2.908
2.5	6.413
3.0	3.026
FCC SPECIFICATION	±2593 MHz (±0.05ppm) ±0.05ppm = ±129.65 Hz
FCC RESULT	PASS

Transmit Frequency Deviation at +25°C at 100% of Nominal Voltage, -48.0VDC	
Time (minutes)	Transmit Carrier Deviation (Hz)
0	5.774
0.5	3.669
1.0	2.107
1.5	1.039
2.0	0.985
2.5	4.621
3.0	5.090
FCC SPECIFICATION	±2593 MHz (±0.05ppm) ±0.05ppm = ±129.65 Hz
FCC RESULT	PASS

Transmit Frequency Deviation at +25°C at -3% of Nominal Voltage, -46.56VDC	
Time (minutes)	Transmit Carrier Deviation (Hz)
0	7.124
0.5	4.192
1.0	2.207
1.5	1.845
2.0	4.088
2.5	2.490
3.0	6.452
FCC SPECIFICATION	±2593 MHz (±0.05ppm) ±0.05ppm = ±129.65 Hz
FCC RESULT	PASS

Transmit Frequency Deviation at +25°C at -6% of Nominal Voltage, -45.12VDC	
Time (minutes)	Transmit Carrier Deviation (Hz)
0	3.030
0.5	5.352
1.0	4.644
1.5	6.700
2.0	7.451
2.5	4.402
3.0	3.778
FCC SPECIFICATION	±2593 MHz (±0.05ppm) ±0.05ppm = ±129.65 Hz
FCC RESULT	PASS

Transmit Frequency Deviation at +25°C at -9% of Nominal Voltage, -43.68VDC	
Time (minutes)	Transmit Carrier Deviation (Hz)
0	7.750
0.5	1.639
1.0	3.199
1.5	7.671
2.0	3.223
2.5	1.287
3.0	4.360
FCC SPECIFICATION	±2593 MHz (±0.05ppm) ±0.05ppm = ±129.65 Hz
FCC RESULT	PASS

Transmit Frequency Deviation at +25°C at -12% of Nominal Voltage, -42.24VDC	
Time (minutes)	Transmit Carrier Deviation (Hz)
0	2.697
0.5	7.901
1.0	4.936
1.5	0.871
2.0	1.431
2.5	3.392
3.0	7.076
FCC SPECIFICATION	±2593 MHz (±0.05ppm) ±0.05ppm = ±129.65 Hz
FCC RESULT	PASS

Transmit Frequency Deviation at +25°C at -15% of Nominal Voltage, -40.80VDC	
Time (minutes)	Transmit Carrier Deviation (Hz)
0	5.621
0.5	3.712
1.0	1.745
1.5	8.371
2.0	1.780
2.5	2.022
3.0	3.397
FCC SPECIFICATION	±2593 MHz (±0.05ppm) ±0.05ppm = ±129.65 Hz
FCC RESULT	PASS

FIGURE 1: TEST SET-UP

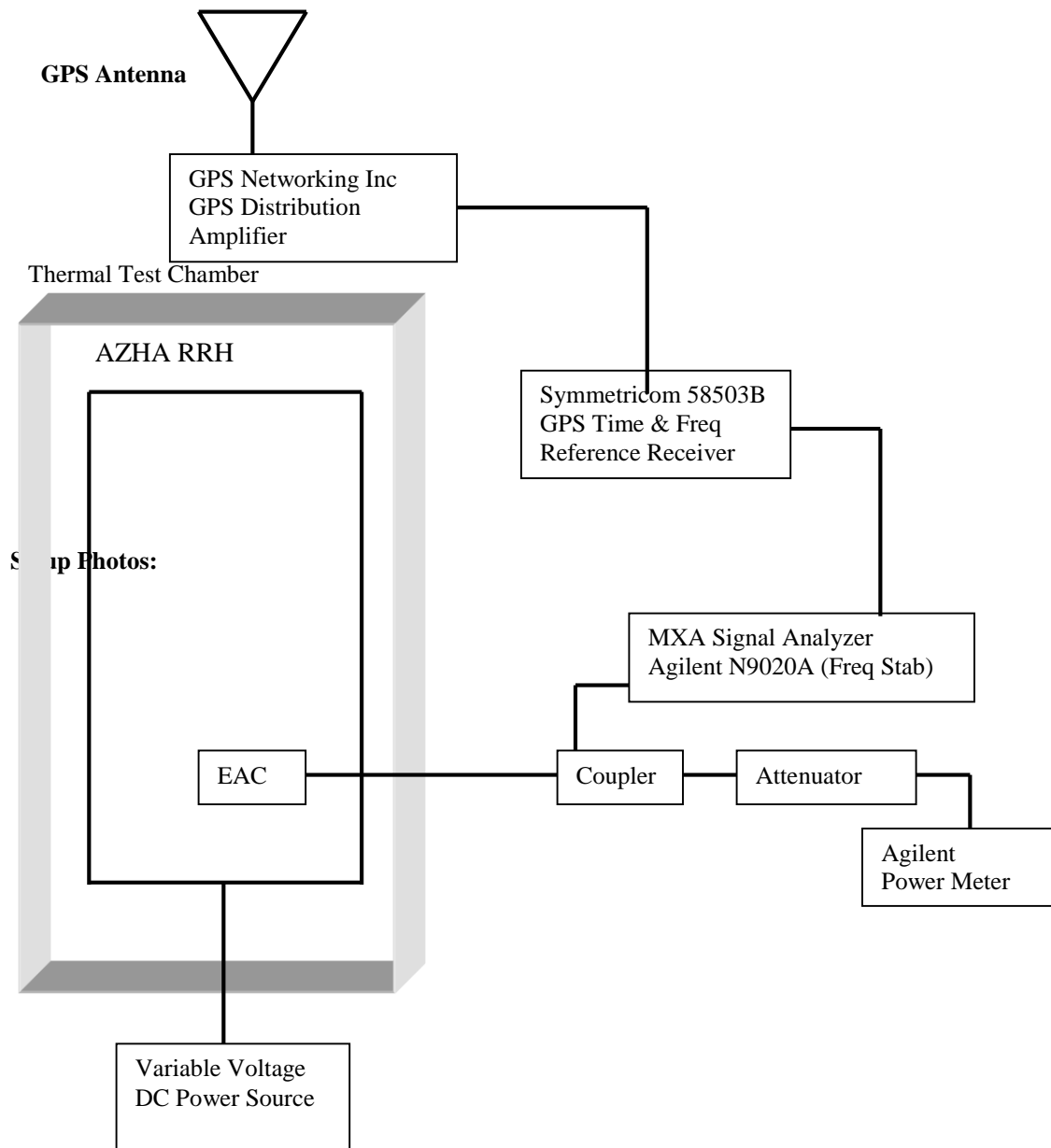

Setup Photos:



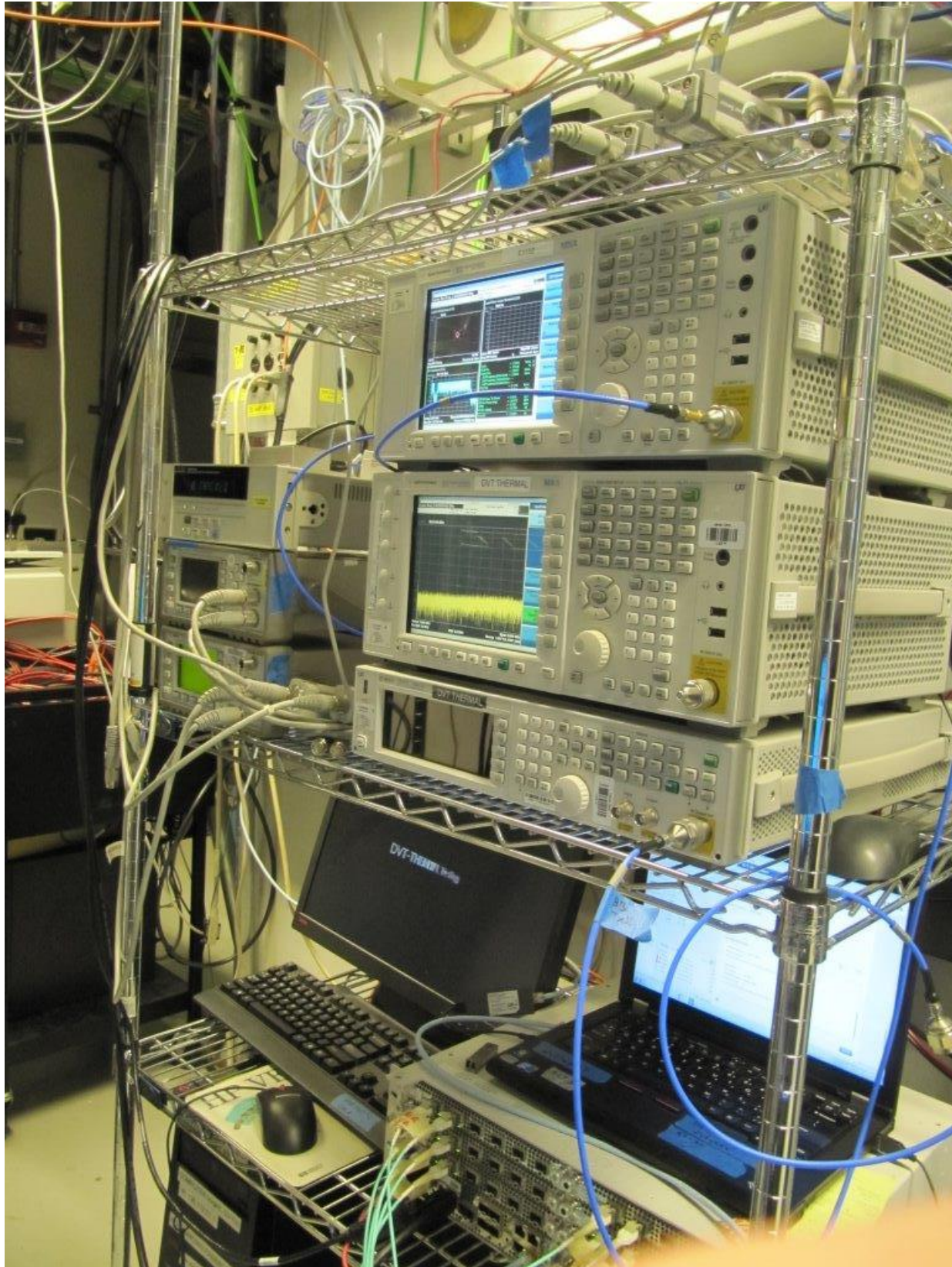

UUT: AZHA AirScale RRH 4TX 2600, PN: 473941A.101, SN: 6Q180516145

Test Equipment

Instrument Type	Serial Number	Vendor	Cal Due Date
MXA Signal Analyzer	MY53420147	AGILENT N9020A	03/13/2019
Power Meter	MY40511034	AGILENT E4419B	01/10/2020
Power Sensor	MY51020039	AGILENT E9300A	09/10/2019
Power Sensor	US39211927	AGILENT E9300A	04/19/2019
Multimeter	74910377	FLUKE 83 III	02/12/2020
Thermal Logger	S5U604860	YOKOGAWA GP10	11/09/2020
GPS Receiver	KR93200773	SYMMETRICOM 58503B	No Cal Req.
Power supply	13N5112J	TDK-LAMBDA GEN60-85-3P208	No Cal Req.

8. NVLAP Certificate of Accreditation

<p>United States Department of Commerce National Institute of Standards and Technology</p>  <hr/> <p>Certificate of Accreditation to ISO/IEC 17025:2005</p> <hr/> <p>NVLAP LAB CODE: 100275-0</p> <p>Nokia, Global Product Compliance Lab Murray Hill, NJ</p> <p><i>is accredited by the National Voluntary Laboratory Accreditation Program for specific services, listed on the Scope of Accreditation, for:</i></p> <p>Electromagnetic Compatibility & Telecommunications</p> <p><i>This laboratory is accredited in accordance with the recognized International Standard ISO/IEC 17025:2005. This accreditation demonstrates technical competence for a defined scope and the operation of a laboratory quality management system (refer to joint ISO-ILAC-IAF Communique dated January 2009).</i></p> <hr/> <table border="0" style="width: 100%;"><tr><td style="width: 40%;"><p>2018-09-05 through 2019-09-30 <i>Effective Dates</i></p></td><td style="width: 20%; text-align: center;"></td><td style="width: 40%;"> <i>For the National Voluntary Laboratory Accreditation Program</i></td></tr></table>		<p>2018-09-05 through 2019-09-30 <i>Effective Dates</i></p>		 <i>For the National Voluntary Laboratory Accreditation Program</i>
<p>2018-09-05 through 2019-09-30 <i>Effective Dates</i></p>		 <i>For the National Voluntary Laboratory Accreditation Program</i>		