

## FCC Test Report (Part 27)

**Report No.:** RF190531C22B

**FCC ID:** VBNAHIB-01

**Model:** AHIB

**Received Date:** Oct. 23, 2019

**Test Date:** Oct. 29 ~ Nov. 02, 2019

**Issued Date:** Nov. 06, 2019

**Applicant:** Nokia Solutions and Networks

**Address:** 6000 Connection Drive, Irving, TX 75039

**Issued By:** Bureau Veritas Consumer Products Services (H.K.) Ltd., Taoyuan Branch  
Lin Kou Laboratories

**Lab Address:** No. 47-2, 14th Ling, Chia Pau Vil., Lin Kou Dist., New Taipei City, Taiwan

**Test Location:** No. 19, Hwa Ya 2nd Rd., Wen Hwa Vil., Kwei Shan Dist., Taoyuan City  
33383, Taiwan

**FCC Registration /** 788550 / TW0003

**Designation Number:**



This report is for your exclusive use. Any copying or replication of this report to or for any other person or entity, or use of our name or trademark, is permitted only with our prior written permission. This report sets forth our findings solely with respect to the test samples identified herein. The results set forth in this report are not indicative or representative of the quality or characteristics of the lot from which a test sample was taken or any similar or identical product specifically and expressly noted. Our report includes all of the tests requested by you and the results thereof based upon the information that you provided to us. You have 60 days from date of issuance of this report to notify us of any material error or omission caused by our negligence, provided, however, that such notice shall be in writing and shall specifically address the issue you wish to raise. A failure to raise such issue within the prescribed time shall constitute your unqualified acceptance of the completeness of this report, the tests conducted and the correctness of the report contents. Unless specific mention, the uncertainty of measurement has been explicitly taken into account to declare the compliance or non-compliance to the specification. The report must not be used by the client to claim product certification, approval, or endorsement by TAF or any government agency

## Table of Contents

<b>Release Control Record</b> .....	<b>4</b>
<b>1 Certificate of Conformity</b> .....	<b>5</b>
<b>2 Summary of Test Results</b> .....	<b>6</b>
2.1 Measurement Uncertainty.....	6
2.2 Test Site and Instruments.....	7
<b>3 General Information</b> .....	<b>8</b>
3.1 General Description of EUT.....	8
3.2 Configuration of System under Test.....	9
3.2.1 Description of Support Units.....	9
3.3 Test Mode Applicability and Tested Channel Detail.....	10
3.4 EUT Operating Conditions.....	11
3.5 General Description of Applied Standards.....	11
<b>4 Test Types and Results</b> .....	<b>12</b>
4.1 Output Power Measurement.....	12
4.1.1 Limits of Output Power Measurement.....	12
4.1.2 Test Procedures.....	12
4.1.3 Test Setup.....	12
4.1.4 Test Results.....	13
4.2 Modulation Characteristics Measurement.....	15
4.2.1 Limits of Modulation Characteristics.....	15
4.2.2 Test Procedure.....	15
4.2.3 Test Setup.....	15
4.2.4 Test Results.....	15
4.3 Frequency Stability Measurement.....	16
4.3.1 Limits of Frequency Stability Measurement.....	16
4.3.2 Test Instruments.....	16
4.3.3 Test Procedure.....	16
4.3.4 Test Setup.....	17
4.3.5 Test Results.....	18
4.4 Emission Bandwidth Measurement.....	19
4.4.1 Limits of Emission Bandwidth Measurement.....	19
4.4.2 Test Procedure.....	19
4.4.3 Test Setup.....	19
4.4.4 Test Result.....	20
4.5 Channel Edge Measurement.....	24
4.5.1 Limits of Band Edge Measurement.....	24
4.5.2 Test Setup.....	24
4.5.3 Test Procedures.....	24
4.5.4 Test Results.....	25
4.6 Peak to Average Ratio.....	27
4.6.1 Limits of Peak to Average Ratio Measurement.....	27
4.6.2 Test Setup.....	27
4.6.3 Test Procedures.....	27
4.6.4 Test Results.....	28
4.7 Conducted Spurious Emissions.....	30
4.7.1 Limits of Conducted Spurious Emissions Measurement.....	30
4.7.2 Test Setup.....	30
4.7.3 Test Procedure.....	30
4.7.4 Test Results.....	31
4.8 Radiated Emission Measurement.....	43
4.8.1 Limits of Radiated Emission Measurement.....	43
4.8.2 Test Procedure.....	43
4.8.3 Deviation from Test Standard.....	43

4.8.4 Test Setup.....	44
4.8.5 Test Results .....	45
<b>5 Pictures of Test Arrangements.....</b>	<b>49</b>
<b>Appendix – Information on the Testing Laboratories .....</b>	<b>50</b>

### Release Control Record

Issue No.	Description	Date Issued
RF190531C22B	Original release	Nov. 06, 2019

## 1 Certificate of Conformity

**Product:** AirScale Base Station RRH 2100MHz

**Brand:** Nokia

**Model:** AHIB

**Sample Status:** Mass product

**Applicant:** Nokia Solutions and Networks

**Test Date:** Oct. 29 ~ Nov. 02, 2019

**Standards:** FCC Part 27, Subpart C, L  
FCC Part 2, Subpart J

The above equipment has been tested by **Bureau Veritas Consumer Products Services (H.K.) Ltd., Taoyuan Branch**, and found compliance with the requirement of the above standards. The test record, data evaluation & Equipment Under Test (EUT) configurations represented herein are true and accurate accounts of the measurements of the sample's RF characteristics under the conditions specified in this report.

**Prepared by :** Pettie Chen , **Date:** Nov. 06, 2019  
Pettie Chen / Senior Specialist

**Approved by :** Bruce Chen , **Date:** Nov. 06, 2019  
Bruce Chen / Senior Project Engineer

## 2 Summary of Test Results

Applied Standard: FCC Part 27 & Part 2			
FCC Clause	Test Item	Result	Remarks
n66			
2.1046 27.50 (d)(2)	Equivalent Isotropically Radiated Power	Pass	Meet the requirement of limit.
2.1047	Modulation Characteristics	Pass	Meet the requirement of limit.
27.50(d)(5)	Peak To Average Ratio	Pass	Meet the requirement of limit.
2.1055 27.54	Frequency Stability Stay with the authorized bands of operation	Pass	Meet the requirement of limit.
2.1049 27.53(h)(3)	Emission Bandwidth	Pass	Meet the requirement of limit.
2.1051 27.53(h)	Band Edge Measurements	Pass	Meet the requirement of limit.
2.1051 27.53(h)	Conducted Spurious Emissions	Pass	Meet the requirement of limit.
2.1053 27.53(h)	Radiated Spurious Emissions	Pass	Meet the requirement of limit. Minimum passing margin is -13.7dB at 31.94MHz.

Note: Determining compliance based on the results of the compliance measurement, not taking into account measurement instrumentation uncertainty.

### 2.1 Measurement Uncertainty

Where relevant, the following measurement uncertainty levels have been estimated for tests performed on the EUT as specified in CISPR 16-4-2:

Measurement	Frequency	Expanded Uncertainty (k=2) ( $\pm$ )
Radiated Emissions up to 1 GHz	9kHz ~ 30MHz	3.04 dB
	30MHz ~ 200MHz	3.59 dB
	200MHz ~ 1000MHz	3.60 dB
Radiated Emissions above 1 GHz	1GHz ~ 18GHz	2.29 dB
	18GHz ~ 40GHz	2.29 dB

## 2.2 Test Site and Instruments

Description & Manufacturer	Model No.	Serial No.	Cal. Date	Cal. Due
Test Receiver KEYSIGHT	N9038A	MY55420137	Apr. 15, 2019	Apr. 14, 2020
Spectrum Analyzer ROHDE & SCHWARZ	FSP40	100269	Jun. 04, 2019	Jun. 03, 2020
BILOG Antenna SCHWARZBECK	VULB9168	9168-160	Nov. 21, 2018	Nov. 20, 2019
HORN Antenna SCHWARZBECK	BBHA 9120 D	9120D-1169	Nov. 25, 2018	Nov. 24, 2019
HORN Antenna SCHWARZBECK	BBHA 9170	BBHA9170241	Nov. 25, 2018	Nov. 24, 2019
Loop Antenna TESEQ	HLA 6121	45745	Jul. 01, 2019	Jun. 30, 2020
Preamplifier Agilent (Below 1GHz)	8447D	2944A10638	Jul. 11, 2019	Jul. 10, 2020
Preamplifier Agilent (Above 1GHz)	8449B	3008A02367	Feb. 19, 2019	Feb. 18, 2020
RF signal cable HUBER+SUHNER&EMCI	SUCOFLEX 104 & EMC104-SM-SM80 00	CABLE-CH9-02 (248780+171006)	Jan. 19, 2019	Jan. 18, 2020
RF signal cable HUBER+SUHNER	SUCOFLEX 104	CABLE-CH9-(250795/4)	Jul. 11, 2019	Jul. 10, 2020
RF signal cable Woken	8D-FB	Cable-CH9-01	Jul. 30, 2019	Jul. 29, 2020
Software BV ADT	ADT_Radiated_ V7.6.15.9.5	NA	NA	NA
Antenna Tower EMCO	2070/2080	512.835.4684	NA	NA
Turn Table EMCO	2087-2.03	NA	NA	NA
Antenna Tower & Turn BV ADT	AT100	AT93021705	NA	NA
Turn Table BV ADT	TT100	TT93021705	NA	NA
Turn Table Controller BV ADT	SC100	SC93021705	NA	NA
Boresight Antenna Fixture	FBA-01	FBA-SIP01	NA	NA

- Note: 1. The calibration interval of the above test instruments is 12 months and the calibrations are traceable to NML/ROC and NIST/USA.  
 2. The test was performed in HwaYa Chamber 9.

### 3 General Information

#### 3.1 General Description of EUT

Product	AirScale Base Station RRH 2100MHz				
Brand	Nokia				
Model	AHIB				
Sample Status	Mass product				
Power Supply Rating	DC: -40.5V to -57VDC AC: 100-240VAC				
Modulation Type	QPSK, 16QAM, 64QAM, 256QAM				
Operating Frequency	2110MHz ~ 2200MHz				
		QPSK	16QAM	64QAM	256QAM
Max. EIRP Power	n66 (Channel Bandwidth: 20MHz)	397191.550mW (55.99dBm)	392644.935mW (55.94dBm)	393550.076mW (55.95dBm)	393550.076mW (55.95dBm)
Emission Designator	n66 (Channel Bandwidth: 20MHz)	19M0G7D	19M0D7W	19M0D7W	19M0D7W
Antenna Type	Direction Panel antenna with 12.5dBi gain (Note 3)				
Antenna Connector	N type				
Antenna Ports	Nex10				
S/N	474050A.102				
HW Version	A102				
SW Version	5G19B				
Accessory Device	Refer to Note 2 as below				
Cable Supplied	NA				

Note:

1. This report is prepared for FCC class II permissive change. This report is issued as a supplementary report of BV CPS report no.: RF190531C22. Difference compared with the original report is adding 5GNR band. Therefore, the EUT was re-tested and presented in the test report.
2. The EUT contains following accessory devices.

AC PSU (Optional)	
Brand	Nokia
Model	APAB
Sales Item	474130A.102
S/N	U7174800066
Remark	SUPLET/S818A16
Input Power	100-240Vac, 50-60Hz, 3A MAX
Output Power	-54Vdc, 3A MAX

3. This device operate with Multiple Antennas Using Multiple-input, Multiple-output (MIMO) Technology for uncorrelated Transmission. Base on NOKIA's declaration that the maximum permissible directional gain is 12.5dBi



### 3.2 Configuration of System under Test

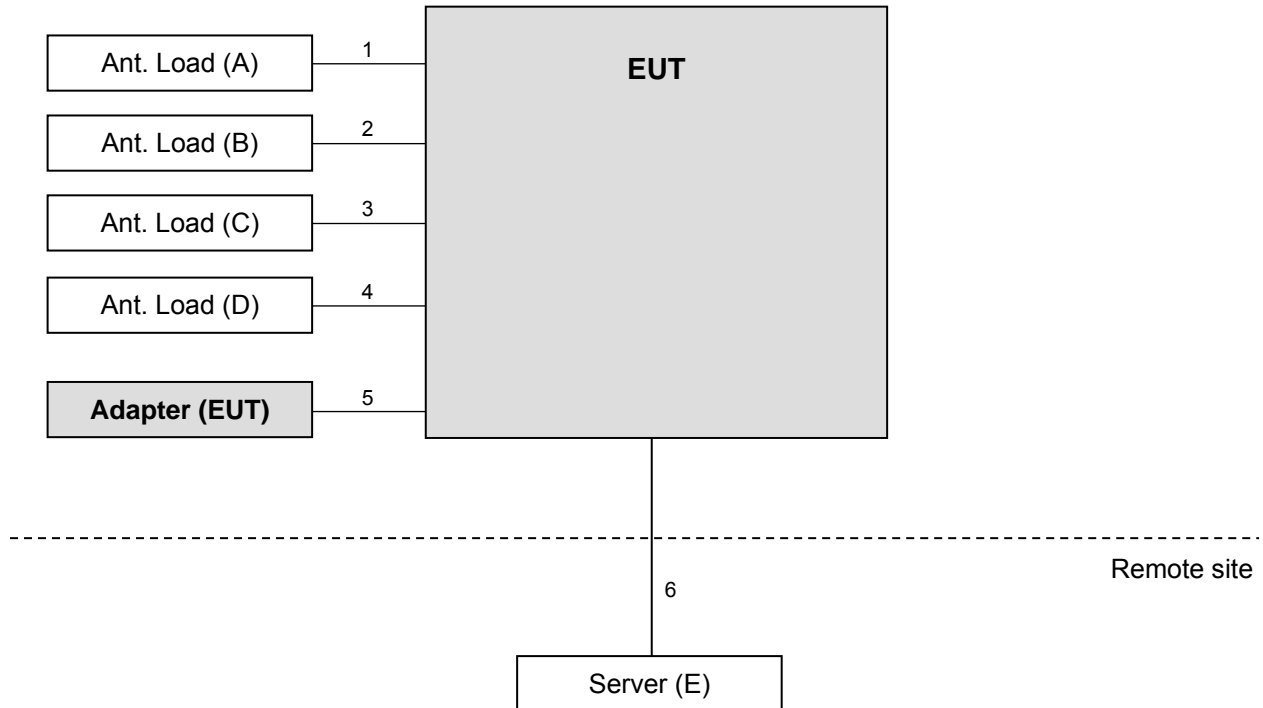

#### 3.2.1 Description of Support Units

The EUT has been tested as an independent unit together with other necessary accessories or support units. The following support units or accessories were used to form a representative test configuration during the tests.

ID	Product	Brand	Model No.	Serial No.	FCC ID	Remarks
A.	Ant. Load	NA	NA	NA	NA	Provided by manufacturer
B.	Ant. Load	NA	NA	NA	NA	Provided by manufacturer
C.	Ant. Load	NA	NA	NA	NA	Provided by manufacturer
D.	Ant. Load	NA	NA	NA	NA	Provided by manufacturer
E.	Server	Nokia	ASIA	L1182006990	NA	Provided by manufacturer

Note:

1. All power cords of the above support units are non-shielded (1.8m).
2. Item E acted as a communication partner to transfer data.

ID	Descriptions	Qty.	Length (m)	Shielding (Yes/No)	Cores (Qty.)	Remarks
1.	Ant. Cable	1	0.3	Y	0	-
2.	Ant. Cable	1	0.3	Y	0	-
3.	Ant. Cable	1	0.3	Y	0	-
4.	Ant. Cable	1	0.3	Y	0	-
5.	DC Cable	1	0.55	N	0	Provided by manufacturer
6.	Fiber Cable	1	2	N	0	-

### 3.3 Test Mode Applicability and Tested Channel Detail

Pre-Scan has been conducted to determine the worst-case mode from all possible combinations between available modulations, data rates, XYZ axis and antenna ports. The worst case was found when positioned on X-plane. Following channel(s) was (were) selected for the final test as listed below.

n66

EUT Configure Mode	Test item	Available channel	Tested Channel	Channel Bandwidth	Modulation	Mode
-	EIRP	424000 to 438000	CH 424000 (2120MHz) CH 431000 (2155MHz) CH 438000 (2190MHz)	20MHz	QPSK / 16QAM / 64QAM / 256QAM	Full RB
-	Modulation Characteristics	424000 to 438000	CH 431000 (2155MHz)	20MHz	QPSK / 16QAM / 64QAM / 256QAM	Full RB
-	Frequency Stability	424000 to 438000	CH 424000 (2120MHz) CH 438000 (2190MHz)	20MHz	QPSK	Full RB
-	Occupied Bandwidth	424000 to 438000	CH 424000 (2120MHz) CH 431000 (2155MHz) CH 438000 (2190MHz)	20MHz	QPSK / 16QAM / 64QAM / 256QAM	Full RB
-	Band Edge	424000 to 438000	CH 424000 (2120MHz) CH 438000 (2190MHz)	20MHz	QPSK	Full RB
-	Peak to Average Ratio	424000 to 438000	CH 424000 (2120MHz) CH 431000 (2155MHz) CH 438000 (2190MHz)	20MHz	QPSK / 16QAM / 64QAM / 256QAM	Full RB
-	Conducted Emission	424000 to 438000	CH 424000 (2120MHz) CH 431000 (2155MHz) CH 438000 (2190MHz)	20MHz	QPSK	Full RB
-	Radiated Emission Below 1GHz	424000 to 438000	CH 431000 (2155MHz)	20MHz	QPSK	Full RB
-	Radiated Emission Above 1GHz	424000 to 438000	CH 424000 (2120MHz) CH 431000 (2155MHz) CH 438000 (2190MHz)	20MHz	QPSK	Full RB

Note:

- For radiated emission below 1GHz, low, mid and high channels were pre-tested in chamber. Middle channel was the worst case for all final tests.
- The conducted output power for QPSK, 16QAM, 64QAM and 256QAM measured value of QPSK is higher than other mode. Therefore, Occupied bandwidth and Peak to average ratio items were tested under QPSK, 16QAM, 64QAM and 256QAM modes, and the other test items were tested under QPSK mode only.

Test Condition:

Test Item	Environmental Conditions	Input Power (system)	Tested By
EIRP	24deg. C, 64%RH	120Vac, 60Hz	James Yang
Modulation Characteristics	24deg. C, 64%RH	120Vac, 60Hz	James Yang
Frequency Stability	24deg. C, 64%RH	-48Vdc	James Yang
Occupied Bandwidth	24deg. C, 64%RH	120Vac, 60Hz	James Yang
Band Edge	24deg. C, 64%RH	120Vac, 60Hz	James Yang
Peak To Average Ratio	24deg. C, 64%RH	120Vac, 60Hz	James Yang
Conducted Emission	24deg. C, 64%RH	120Vac, 60Hz	James Yang
Radiated Emission	24deg. C, 68%RH 22deg. C, 68%RH	120Vac, 60Hz	Greg Lin

### **3.4 EUT Operating Conditions**

The EUT makes a call to the communication simulator. The communication simulator station system controlled a EUT to export maximum output power under transmission mode and specific channel frequency

### **3.5 General Description of Applied Standards**

The EUT is a RF Product. According to the specifications of the manufacturer, it must comply with the requirements of the following standards:

**FCC 47 CFR Part 2**

**FCC 47 CFR Part 27**

**KDB 971168 D01 Power Meas License Digital Systems v03r01**

**ANSI/TIA/EIA-603-E 2016**

**ANSI 63.26-2015**

All test items have been performed and recorded as per the above standards.

## 4 Test Types and Results

### 4.1 Output Power Measurement

#### 4.1.1 Limits of Output Power Measurement

The radiated peak output power shall be according to the specific rule Part 27.50(d)(2) that are limited to EIRP of 1640 watts/MHz when transmitting with an emission bandwidth greater than 1 MHz.

#### 4.1.2 Test Procedures

##### Conducted Power Measurement:

The EUT was set up for the maximum power link data modulation and link up with spectrum. Set the EUT to transmit under low, middle and high channel and record the power level.

$EIRP = \text{Conducted Power} + \text{gain}$

#### 4.1.3 Test Setup

CONDUCTED POWER MEASUREMENT:

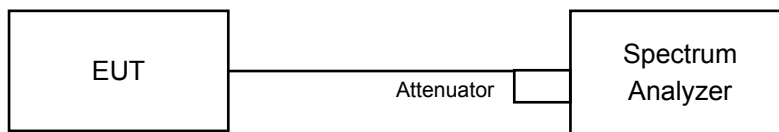

For the actual test configuration, please refer to the attached file (Test Setup Photo).

#### 4.1.4 Test Results

##### Conducted Output Power (dBm)

###### 1TX

Band / BW	Chain	QPSK			16QAM			64QAM			256QAM		
		Low CH	Mid CH	High CH	Low CH	Mid CH	High CH	Low CH	Mid CH	High CH	Low CH	Mid CH	High CH
		424000	431000	438000	424000	431000	438000	424000	431000	438000	424000	431000	438000
		2120	2155	2190	2120	2155	2190	2120	2155	2190	2120	2155	2190
		MHz	MHz	MHz	MHz	MHz	MHz	MHz	MHz	MHz	MHz	MHz	MHz
66 / 20M	0	37.20	37.23	37.61	37.15	37.20	37.52	37.16	37.25	37.53	37.11	37.22	37.55
	1	37.17	37.13	37.49	37.11	37.15	37.41	37.12	37.10	37.46	37.16	37.10	37.43
	2	37.27	37.19	37.45	37.23	37.11	37.45	37.23	37.13	37.40	37.28	37.14	37.46
	3	37.19	37.15	37.34	37.16	37.12	37.29	37.14	37.12	37.31	37.20	37.11	37.28

###### 2TX

Band / BW	Chain	QPSK			16QAM			64QAM			256QAM		
		Low CH	Mid CH	High CH	Low CH	Mid CH	High CH	Low CH	Mid CH	High CH	Low CH	Mid CH	High CH
		424000	431000	438000	424000	431000	438000	424000	431000	438000	424000	431000	438000
		2120	2155	2190	2120	2155	2190	2120	2155	2190	2120	2155	2190
		MHz	MHz	MHz	MHz	MHz	MHz	MHz	MHz	MHz	MHz	MHz	MHz
66 / 20M	0+1	40.20	40.19	40.56	40.14	40.19	40.48	40.15	40.19	40.51	40.15	40.17	40.50
	2+3	40.24	40.18	40.41	40.21	40.13	40.38	40.20	40.14	40.37	40.25	40.14	40.38

###### 3TX

Band / BW	Chain	QPSK			16QAM			64QAM			256QAM		
		Low CH	Mid CH	High CH	Low CH	Mid CH	High CH	Low CH	Mid CH	High CH	Low CH	Mid CH	High CH
		424000	431000	438000	424000	431000	438000	424000	431000	438000	424000	431000	438000
		2120	2155	2190	2120	2155	2190	2120	2155	2190	2120	2155	2190
		MHz	MHz	MHz	MHz	MHz	MHz	MHz	MHz	MHz	MHz	MHz	MHz
66 / 20M	0+1+2	41.98	41.95	42.29	41.93	41.92	42.23	41.94	41.93	42.23	41.96	41.92	42.25

###### 4TX

Band / BW	Chain	QPSK			16QAM			64QAM			256QAM		
		Low CH	Mid CH	High CH	Low CH	Mid CH	High CH	Low CH	Mid CH	High CH	Low CH	Mid CH	High CH
		424000	431000	438000	424000	431000	438000	424000	431000	438000	424000	431000	438000
		2120	2155	2190	2120	2155	2190	2120	2155	2190	2120	2155	2190
		MHz	MHz	MHz	MHz	MHz	MHz	MHz	MHz	MHz	MHz	MHz	MHz
66 / 20M	0+1+2+3	43.23	43.20	43.49	43.18	43.17	43.44	43.18	43.17	43.45	43.21	43.16	43.45

\*All available TX Chain combination as below:

###### 2TX:

1. Chain 0+ Chain 1
2. Chain 0+ Chain 2
3. Chain 0+ Chain 3
4. Chain 1+ Chain 2
5. Chain 1+ Chain 3
6. Chain 2+ Chain 3

The worst combination is Chain 0+Chain 1 & Chain 2+Chain 3, therefore they were chosen for the final test.

###### 3TX:

1. Chain 0+ Chain 1+ Chain 2
2. Chain 0+ Chain 1+ Chain 3
3. Chain 1+ Chain 2+ Chain 3

The worst combination is Chain 0+Chain 1+Chain 2, therefore it was chosen for the final test.

**EIRP Power (dBm)**
**1TX**

Band / BW	Chain	QPSK			16QAM			64QAM			256QAM		
		Low CH	Mid CH	High CH	Low CH	Mid CH	High CH	Low CH	Mid CH	High CH	Low CH	Mid CH	High CH
		424000	431000	438000	424000	431000	438000	424000	431000	438000	424000	431000	438000
		2120	2155	2190	2120	2155	2190	2120	2155	2190	2120	2155	2190
		MHz	MHz	MHz	MHz	MHz	MHz	MHz	MHz	MHz	MHz	MHz	MHz
66 / 20M	0	49.70	49.73	50.11	49.65	49.70	50.02	49.66	49.75	50.03	49.61	49.72	50.05
	1	49.67	49.63	49.99	49.61	49.65	49.91	49.62	49.60	49.96	49.66	49.60	49.93
	2	49.77	49.69	49.95	49.73	49.61	49.95	49.73	49.63	49.90	49.78	49.64	49.96
	3	49.69	49.65	49.84	49.66	49.62	49.79	49.64	49.62	49.81	49.70	49.61	49.78

**2TX**

Band / BW	Chain	QPSK			16QAM			64QAM			256QAM		
		Low CH	Mid CH	High CH	Low CH	Mid CH	High CH	Low CH	Mid CH	High CH	Low CH	Mid CH	High CH
		424000	431000	438000	424000	431000	438000	424000	431000	438000	424000	431000	438000
		2120	2155	2190	2120	2155	2190	2120	2155	2190	2120	2155	2190
		MHz	MHz	MHz	MHz	MHz	MHz	MHz	MHz	MHz	MHz	MHz	MHz
66 / 20M	0+1	52.70	52.69	53.06	52.64	52.69	52.98	52.65	52.69	53.01	52.65	52.67	53.00
	2+3	52.74	52.68	52.91	52.71	52.63	52.88	52.70	52.64	52.87	52.75	52.64	52.88

**3TX**

Band / BW	Chain	QPSK			16QAM			64QAM			256QAM		
		Low CH	Mid CH	High CH	Low CH	Mid CH	High CH	Low CH	Mid CH	High CH	Low CH	Mid CH	High CH
		424000	431000	438000	424000	431000	438000	424000	431000	438000	424000	431000	438000
		2120	2155	2190	2120	2155	2190	2120	2155	2190	2120	2155	2190
		MHz	MHz	MHz	MHz	MHz	MHz	MHz	MHz	MHz	MHz	MHz	MHz
66 / 20M	0+1+2	54.48	54.45	54.79	54.43	54.42	54.73	54.44	54.43	54.73	54.46	54.42	54.75

**4TX**

Band / BW	Chain	QPSK			16QAM			64QAM			256QAM		
		Low CH	Mid CH	High CH	Low CH	Mid CH	High CH	Low CH	Mid CH	High CH	Low CH	Mid CH	High CH
		424000	431000	438000	424000	431000	438000	424000	431000	438000	424000	431000	438000
		2120	2155	2190	2120	2155	2190	2120	2155	2190	2120	2155	2190
		MHz	MHz	MHz	MHz	MHz	MHz	MHz	MHz	MHz	MHz	MHz	MHz
66 / 20M	0+1+2+3	55.73	55.70	55.99	55.68	55.67	55.94	55.68	55.67	55.95	55.71	55.66	55.95

\*All available TX Chain combination as below:

**2TX:**

1. Chain 0+ Chain 1
2. Chain 0+ Chain 2
3. Chain 0+ Chain 3
4. Chain 1+ Chain 2
5. Chain 1+ Chain 3
6. Chain 2+ Chain 3

The worst combination is Chain 0+Chain 1 & Chain 2+Chain 3, therefore they were chosen for the final test.

**3TX:**

1. Chain 0+ Chain 1+ Chain 2
2. Chain 0+ Chain 1+ Chain 3
3. Chain 1+ Chain 2+ Chain 3

The worst combination is Chain 0+Chain 1+Chain 2, therefore it was chosen for the final test.

## 4.2 Modulation Characteristics Measurement

### 4.2.1 Limits of Modulation Characteristics

N/A

### 4.2.2 Test Procedure

Connect the EUT to Communication Simulator via the antenna connector, the frequency band is set as EUT supported Modulation and Channels, the EUT output is matched with 50 ohm load, the waveform quality and constellation of the EUT was tested.

### 4.2.3 Test Setup



### 4.2.4 Test Results

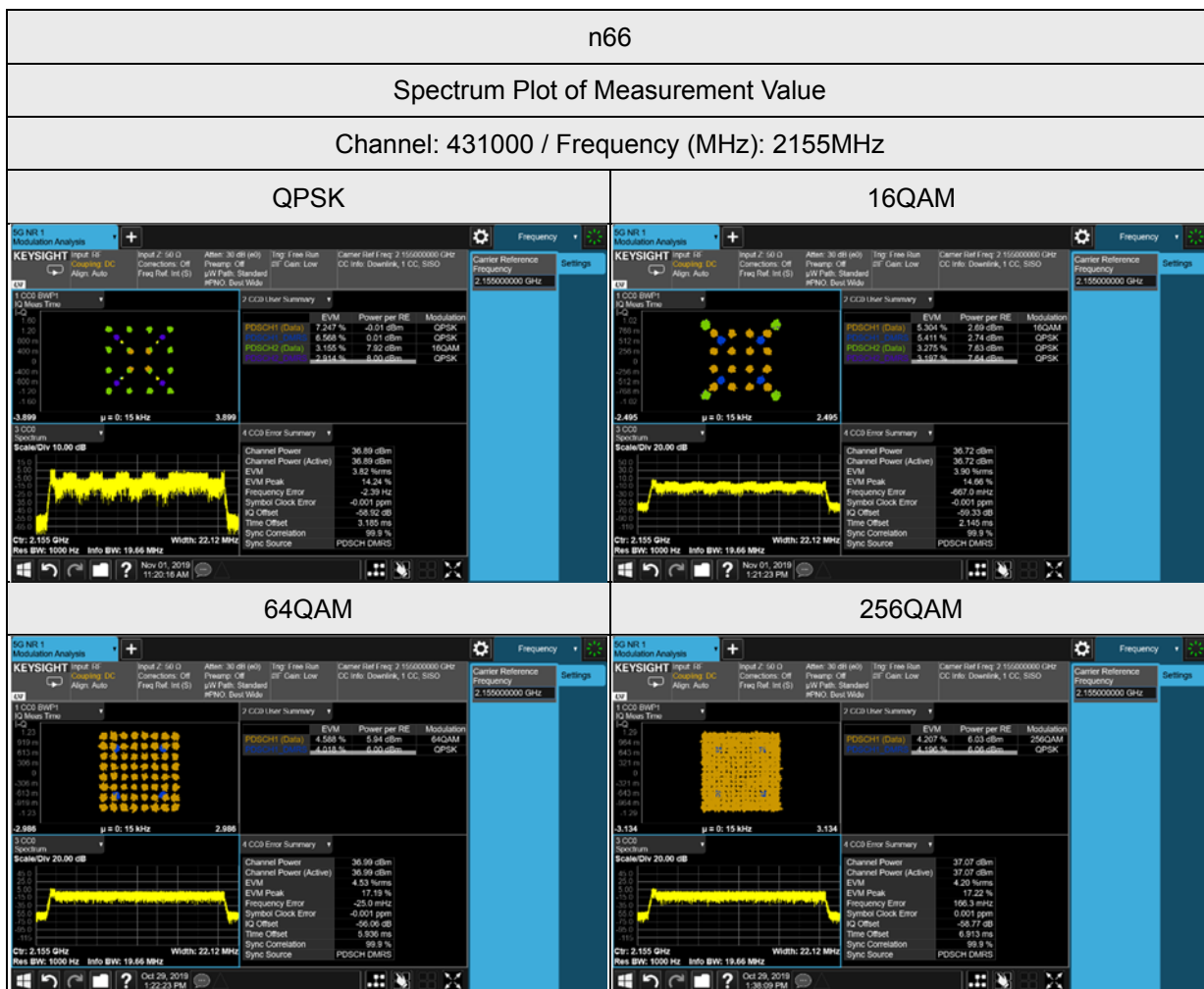

### 4.3 Frequency Stability Measurement

#### 4.3.1 Limits of Frequency Stability Measurement

According to the FCC part 2.1055 shall be tested the frequency stability. The rule is defined that "The frequency stability shall be sufficient to ensure that the fundamental emission stays within the authorized frequency block." The test extreme voltage is according to the 2.1055(d)(1) Vary primary supply voltage from 85 to 115 percent of the nominal value for other than hand carried battery equipment and the extreme temperature rule is comply with specification of EUT  $-30^{\circ}\text{C} \sim 50^{\circ}\text{C}$ .

#### 4.3.2 Test Instruments

Description & Manufacturer	Model No.	Serial No.	Cal. Date	Cal. Due
Spectrum Analyzer ROHDE & SCHWARZ	FSP40	100040	Sep. 23, 2019	Sep. 22, 2020
WIT Standard Temperature And Humidity Chamber	TH-4S-C	W981030	Jun. 03, 2019	Jun. 02, 2020
Digital Multimeter Fluke	87-III	70360742	Jun. 27, 2019	Jun. 26, 2020
DC Power Supply Topward	6306A	727263	NA	NA
True RMS Clamp Meter / Fluke	325	31130711WS	May 21, 2019	May 20, 2020

#### 4.3.3 Test Procedure

- Device is placed at the oven room. The oven room could control the temperatures and humidity. Power warm up is at least 15 min and power applied should perform before recording frequency error.
- EUT is connected the external power supply to control the DC input power. The test voltage range is from minimum to maximum working voltage. Each step shall be record the frequency error rate.
- The temperature range step is 10 degrees in this test items. All temperature levels shall be hold the  $\pm 0.5^{\circ}\text{C}$  during the measurement testing. The each temperature step shall be at least 0.5 hours, consider the EUT could be test under the stability condition.

Note: The frequency error was recorded frequency error from the communication simulator.



#### 4.3.4 Test Setup

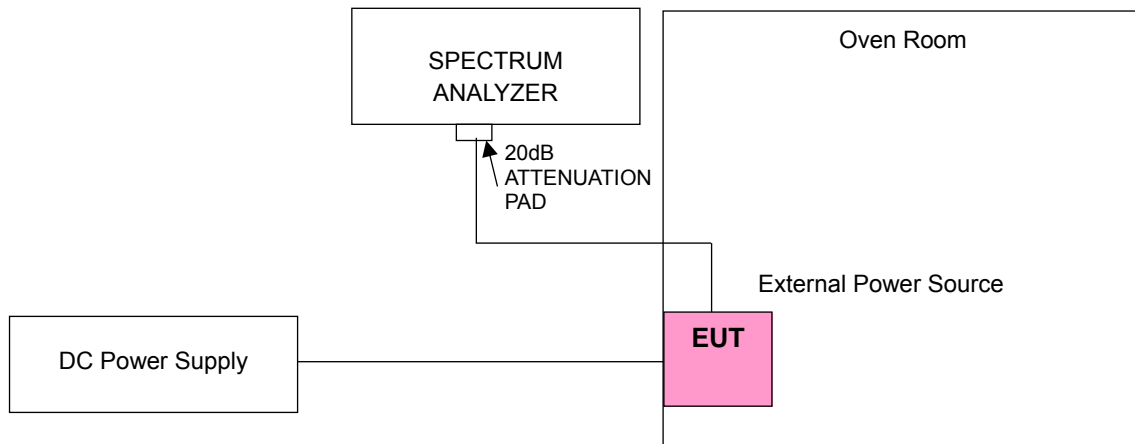

#### 4.3.5 Test Results

##### Frequency Error vs. Voltage

Voltage (Volts)	n66			
	Channel Bandwidth: 20 MHz			
	Low Channel		High Channel	
	Frequency (MHz)	Frequency Error (ppm)	Frequency (MHz)	Frequency Error (ppm)
-48	2120.000002	0.001	2190.000004	0.002
-40.5	2120.000003	0.001	2190.000001	0.000
-57.0	2120.000003	0.001	2190.000003	0.001

Note: The applicant defined the normal working voltage is from -40.5Vdc to -57.0Vdc.

##### Frequency Error vs. Temperature

Temp. (°C)	n66			
	Channel Bandwidth: 20 MHz			
	Low Channel		High Channel	
	Frequency (MHz)	Frequency Error (ppm)	Frequency (MHz)	Frequency Error (ppm)
-30	2120.000002	0.001	2190.000003	0.001
-20	2120.000003	0.001	2190.000001	0.001
-10	2120.000004	0.002	2190.000002	0.001
0	2120.000002	0.001	2190.000003	0.001
10	2120.000003	0.001	2190.000003	0.002
20	2119.999998	-0.001	2189.999998	-0.001
30	2119.999997	-0.001	2189.999998	-0.001
40	2119.999997	-0.001	2189.999999	-0.001
50	2119.999996	-0.002	2189.999999	-0.001

## 4.4 Emission Bandwidth Measurement

### 4.4.1 Limits of Emission Bandwidth Measurement

According to FCC 27.53(m)(6) specified that emission bandwidth is defined as the width of the signal between two points, one below the carrier center frequency and one above the carrier center frequency, outside of which all emissions are attenuated at least 26dB below the transmitter power.

### 4.4.2 Test Procedure

The transmitter output was connected to the spectrum analyzer through an attenuator. The bandwidth of the fundamental frequency was measured by spectrum analyzer with RBW = 200kHz and VBW = 620kHz (Channel Bandwidth: 20MHz).

### 4.4.3 Test Setup

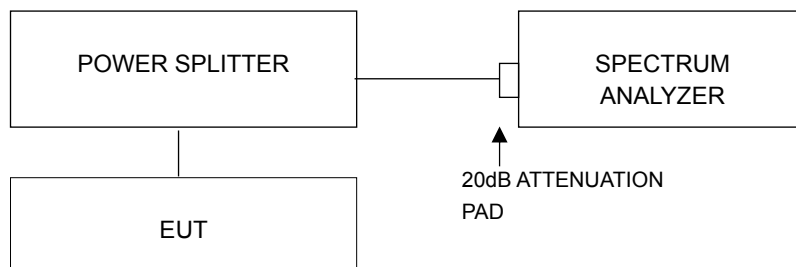

#### 4.4.4 Test Result

##### 99% Occupied Bandwidth

n66, Channel Bandwidth 20MHz					
Channel	Frequency (MHz)	99% Occupied Bandwidth (MHz)			
		QPSK			
		Chain 0	Chain 1	Chain 2	Chain 3
424000	2120	19.056	19.064	19.068	19.063
431000	2155	19.062	19.071	19.061	19.070
438000	2190	19.047	19.039	19.052	19.050

n66, Channel Bandwidth 20MHz					
Channel	Frequency (MHz)	99% Occupied Bandwidth (MHz)			
		16QAM			
		Chain 0	Chain 1	Chain 2	Chain 3
424000	2120	19.081	19.075	19.076	19.055
431000	2155	19.065	19.070	19.083	19.027
438000	2190	19.060	19.054	19.055	19.047

n66, Channel Bandwidth 20MHz					
Channel	Frequency (MHz)	99% Occupied Bandwidth (MHz)			
		64QAM			
		Chain 0	Chain 1	Chain 2	Chain 3
424000	2120	19.006	19.023	19.006	19.023
431000	2155	19.014	19.026	19.040	19.013
438000	2190	18.993	19.017	19.020	19.024

n66, Channel Bandwidth 20MHz					
Channel	Frequency (MHz)	99% Occupied Bandwidth (MHz)			
		256QAM			
		Chain 0	Chain 1	Chain 2	Chain 3
424000	2120	19.026	19.015	19.010	19.026
431000	2155	19.019	19.023	19.006	19.035
438000	2190	18.998	19.020	19.005	19.021

### Spectrum Plot of Worst Value

#### QPSK / Chain 1

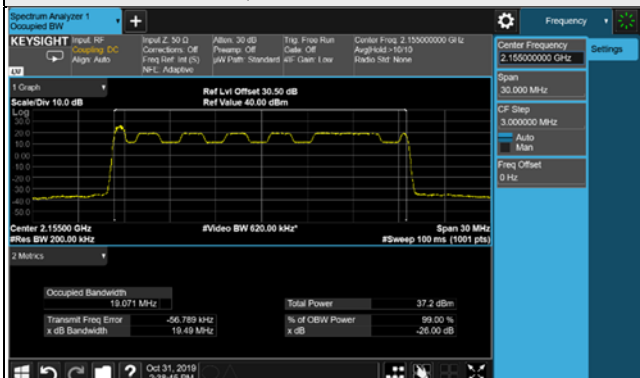

#### 16QAM / Chain 2

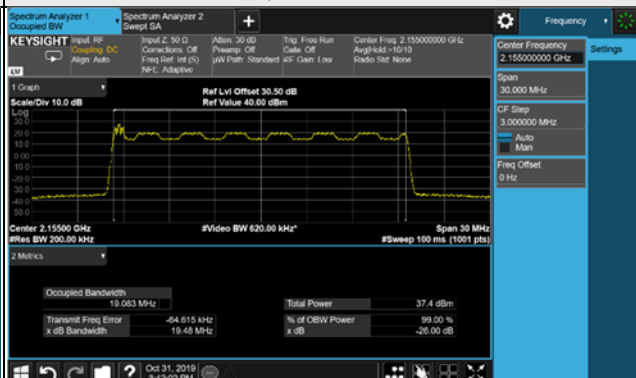

#### 64QAM / Chain 2

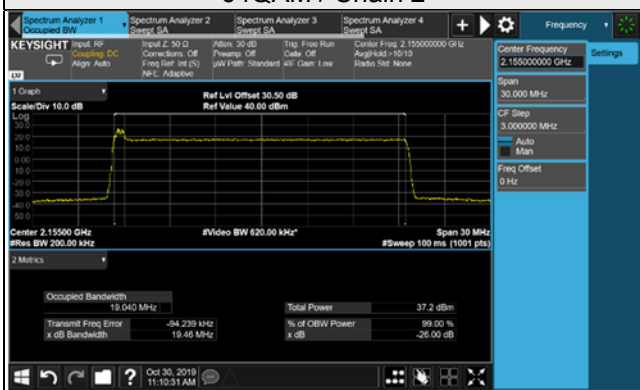

#### 256QAM / Chain 3

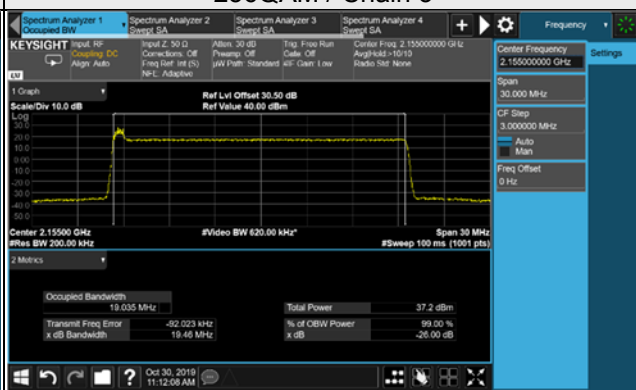

### 26dB Bandwidth

n66, Channel Bandwidth 20MHz					
Channel	Frequency (MHz)	26dBc Bandwidth (MHz)			
		QPSK			
		Chain 0	Chain 1	Chain 2	Chain 3
424000	2120	19.51	19.49	19.51	19.51
431000	2155	19.50	19.49	19.52	19.49
438000	2190	19.50	19.44	19.50	19.50

n66, Channel Bandwidth 20MHz					
Channel	Frequency (MHz)	26dBc Bandwidth (MHz)			
		16QAM			
		Chain 0	Chain 1	Chain 2	Chain 3
424000	2120	19.47	19.49	19.49	19.50
431000	2155	19.50	19.50	19.48	19.49
438000	2190	19.49	19.48	19.49	19.51

n66, Channel Bandwidth 20MHz					
Channel	Frequency (MHz)	26dBc Bandwidth (MHz)			
		64QAM			
		Chain 0	Chain 1	Chain 2	Chain 3
424000	2120	19.49	19.49	19.49	19.48
431000	2155	19.48	19.48	19.46	19.48
438000	2190	19.48	19.45	19.44	19.47

n66, Channel Bandwidth 20MHz					
Channel	Frequency (MHz)	26dBc Bandwidth (MHz)			
		256QAM			
		Chain 0	Chain 1	Chain 2	Chain 3
424000	2120	19.49	19.48	19.47	19.48
431000	2155	19.48	19.48	19.48	19.46
438000	2190	19.48	19.47	19.47	19.47

### Spectrum Plot of Worst Value

**QPSK / Chain 2**

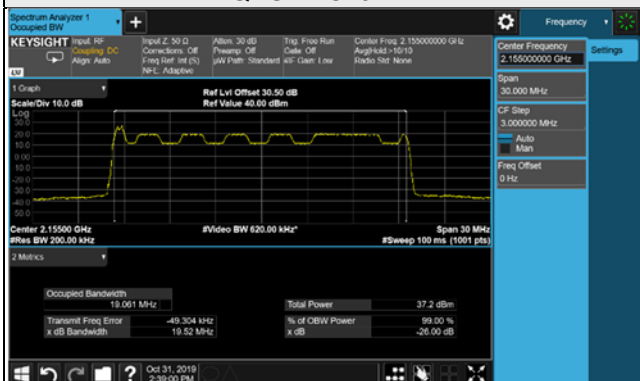

**16QAM / Chain 3**

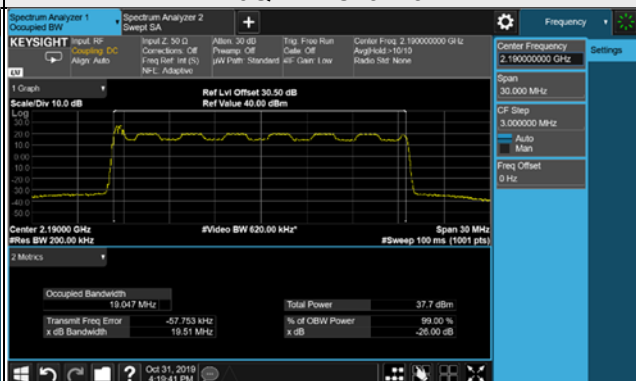

**64QAM / Chain 0**

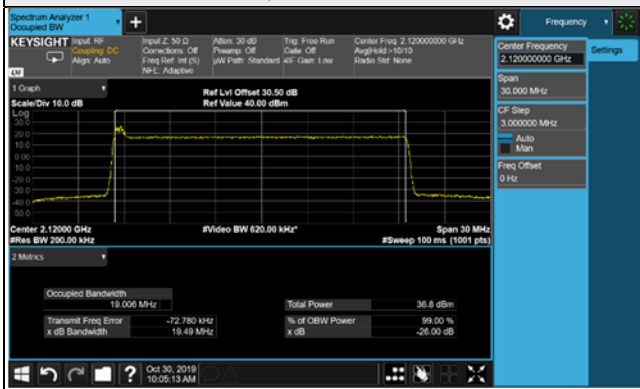

**256QAM / Chain 0**

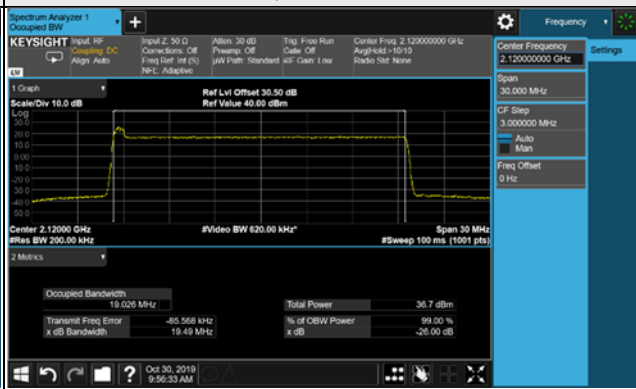

## 4.5 Channel Edge Measurement

### 4.5.1 Limits of Band Edge Measurement

According to FCC 27.53(h) for operations in the 1695-1710 MHz, 1710-1755 MHz, 1755-1780 MHz, 1915-1920 MHz, 1995-2000 MHz, 2000-2020 MHz, 2110-2155 MHz, 2155-2180 MHz, and 2180-2200 bands, the power of any emission outside a licensee's frequency block shall be attenuated below the transmitter power (P) in watts by at least  $43 + 10 \log (P)$  dB.

Note: This device can be implement MIMO function, so the limit of spurious emissions needs to be reduced by  $10\log(\text{Numbers}_{\text{Ant}})$  according to FCC KDB 662911 D01 guidance.

### 4.5.2 Test Setup

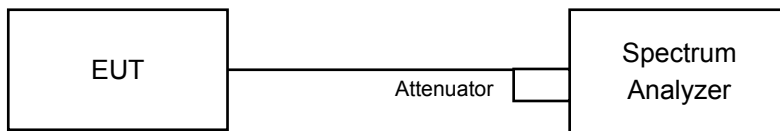

### 4.5.3 Test Procedures

- All measurements were done at low and high operational frequency range.
- The center frequency of spectrum is the band edge frequency and span is 1.5MHz. RB of the spectrum is 200kHz and VB of the spectrum is 620kHz (Channel Bandwidth 20MHz).
- Record the max trace plot into the test report.



### 4.5.4 Test Results



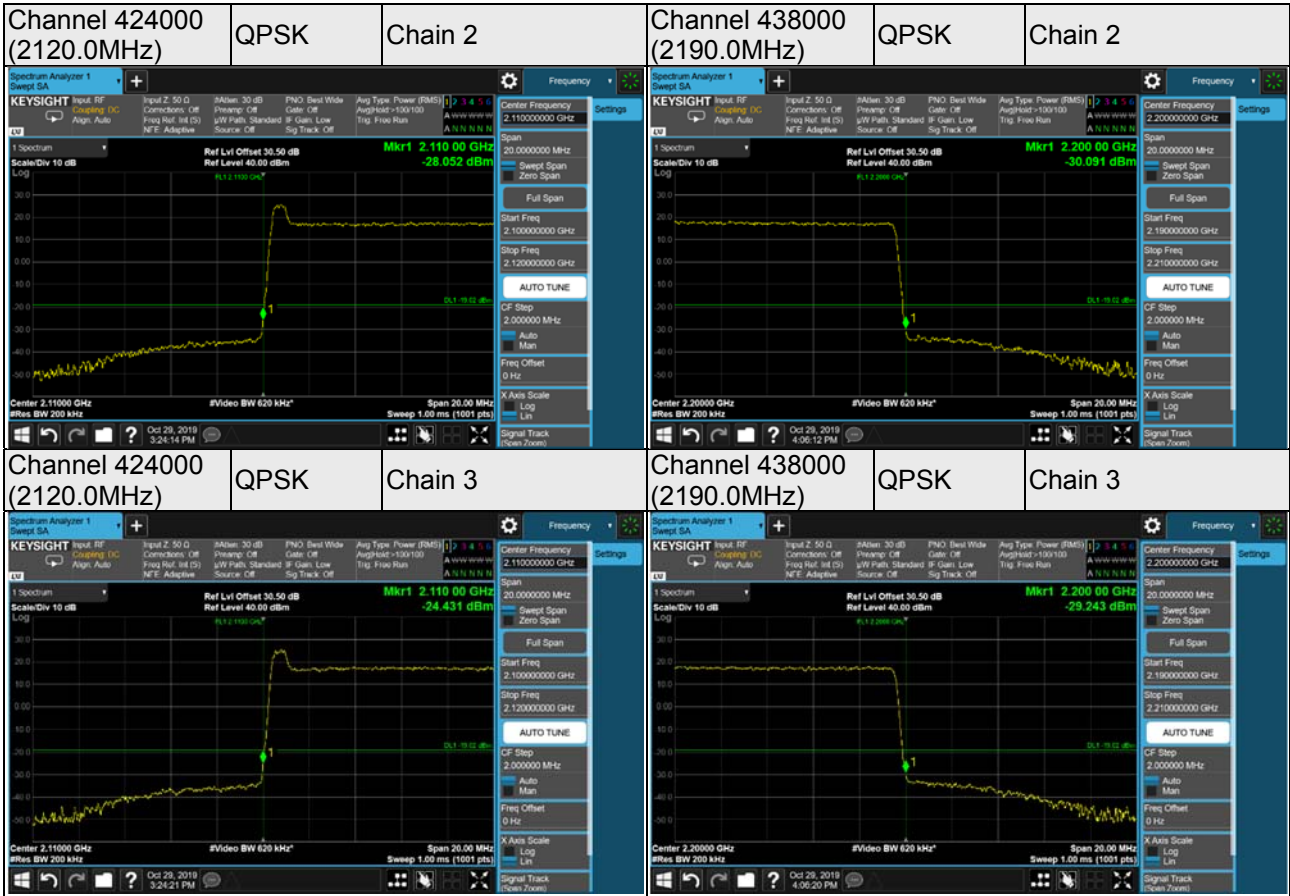

## 4.6 Peak to Average Ratio

### 4.6.1 Limits of Peak to Average Ratio Measurement

In measuring transmissions in this band using an average power technique, the peak to-average ratio (PAR) of the transmission may not exceed 13 dB

### 4.6.2 Test Setup

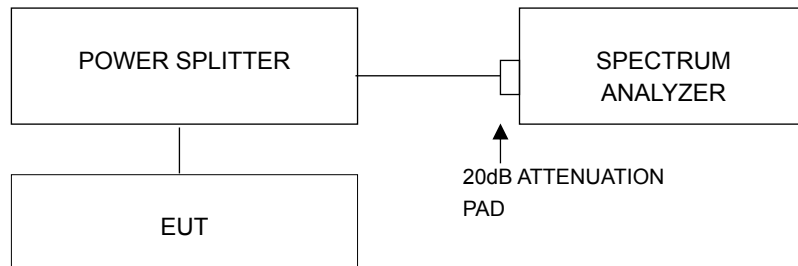

### 4.6.3 Test Procedures

- Set resolution/measurement bandwidth  $\geq$  signal's occupied bandwidth;
- Set the number of counts to a value that stabilizes the measured CCDF curve;
- Record the maximum PAPR level associated with a probability of 0.1%.

#### 4.6.4 Test Results

n66, Channel Bandwidth 20MHz					
Channel	Frequency (MHz)	Peak To Average Ratio (dB)			
		QPSK			
		Chain 0	Chain 1	Chain 2	Chain 3
424000	2120	7.13	7.12	7.07	7.12
431000	2155	7.02	7.01	7.03	7.01
438000	2190	7.05	7.08	7.06	7.06

n66, Channel Bandwidth 20MHz					
Channel	Frequency (MHz)	Peak To Average Ratio (dB)			
		16QAM			
		Chain 0	Chain 1	Chain 2	Chain 3
424000	2120	7.12	7.10	7.12	7.08
431000	2155	7.03	7.03	7.03	7.03
438000	2190	7.10	7.11	7.11	7.11

n66, Channel Bandwidth 20MHz					
Channel	Frequency (MHz)	Peak To Average Ratio (dB)			
		64QAM			
		Chain 0	Chain 1	Chain 2	Chain 3
424000	2120	7.13	7.10	7.12	7.12
431000	2155	7.02	7.01	7.04	7.03
438000	2190	7.10	7.08	7.10	7.10

n66, Channel Bandwidth 20MHz					
Channel	Frequency (MHz)	Peak To Average Ratio (dB)			
		256QAM			
		Chain 0	Chain 1	Chain 2	Chain 3
424000	2120	7.11	7.12	7.11	7.12
431000	2155	7.04	7.03	7.03	7.02
438000	2190	7.09	7.12	7.11	7.07

### Spectrum Plot of Worst Value

QPSK / Chain 0

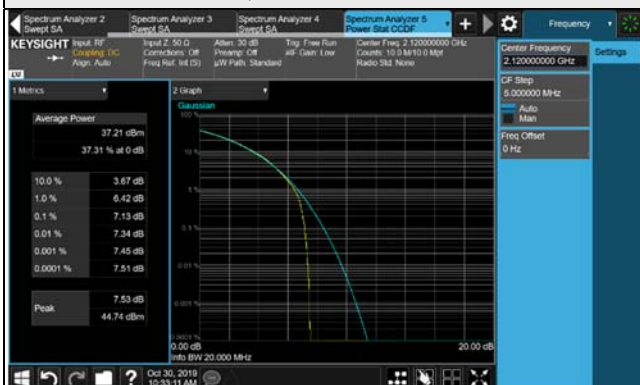

16QAM / Chain 1

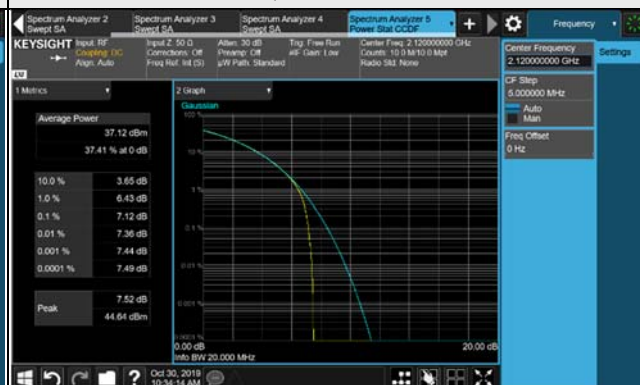

64QAM / Chain 0

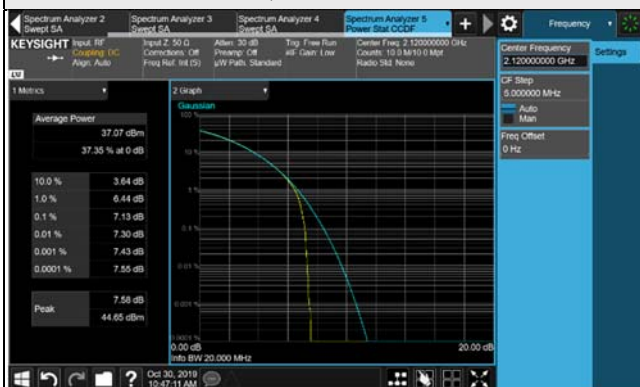

256QAM / Chain 1

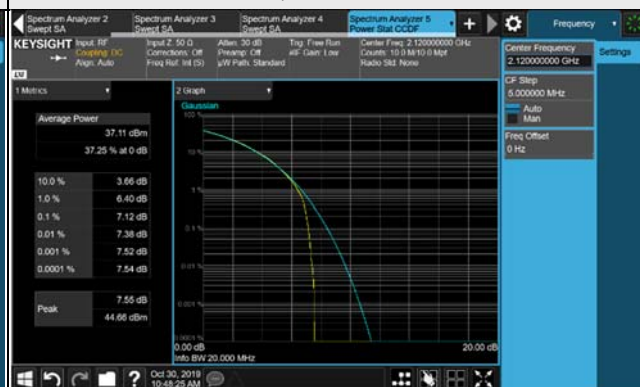

## 4.7 Conducted Spurious Emissions

### 4.7.1 Limits of Conducted Spurious Emissions Measurement

In the FCC 27.53(h)(1), On any frequency outside a licensee's frequency block, The power of any emission shall be attenuated below the transmitter power (P) by at least  $43 + 10 \log (P)$  dB.

Note: This device can be implement MIMO function, so the limit of spurious emissions needs to be reduced by  $10 \log(\text{Numbers}_{\text{Ant}})$  according to FCC KDB 662911 D01 guidance.

### 4.7.2 Test Setup

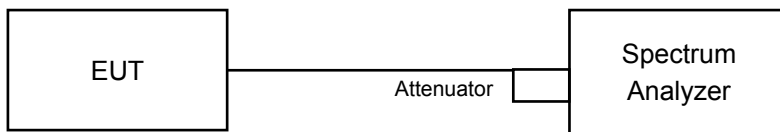

### 4.7.3 Test Procedure

- a. All measurements were done at 3 channels: low, middle and high operational frequency range.
- b. When the spectrum scanned from 9kHz to 26GHz, it shall be connected to the attenuator with the carried frequency.

### 4.7.4 Test Results

n66, Channel Bandwidth 20MHz, Chain 0

Channel 424000 (2120.0MHz)

Frequency Range : 9kHz~1GHz

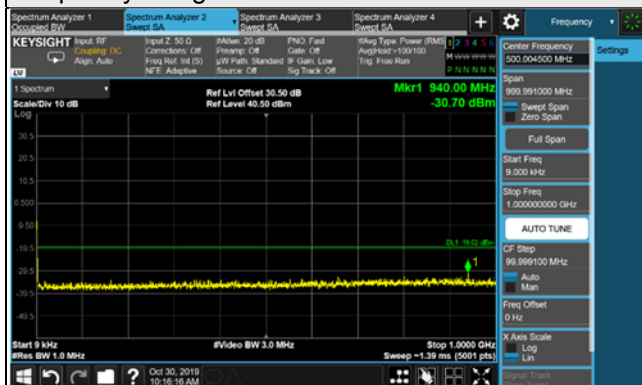

Frequency Range : 1GHz~13GHz



Frequency Range : 13GHz~26GHz



n66, Channel Bandwidth 20MHz, Chain 0

Channel 431000 (2155MHz)

Frequency Range : 9kHz~1GHz

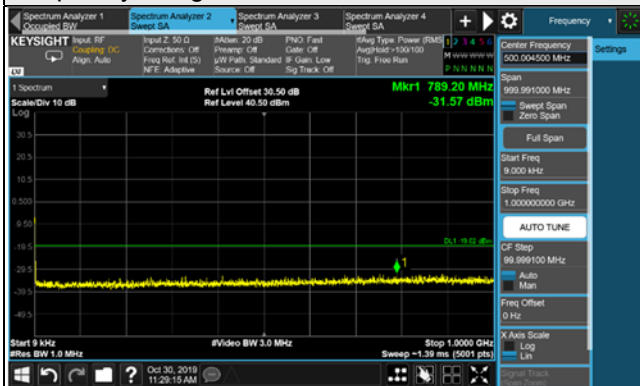

Frequency Range : 1GHz~13GHz



Frequency Range : 13GHz~26GHz





n66, Channel Bandwidth 20MHz, Chain 0

Channel 438000 (2190.0MHz)

Frequency Range : 9kHz~1GHz

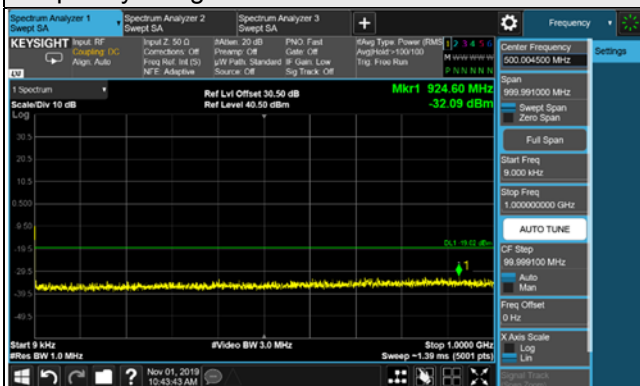

Frequency Range : 1GHz~13GHz



Frequency Range : 13GHz~26GHz



n66, Channel Bandwidth 20MHz, Chain 1

Channel 424000 (2120.0MHz)

Frequency Range : 9kHz~1GHz

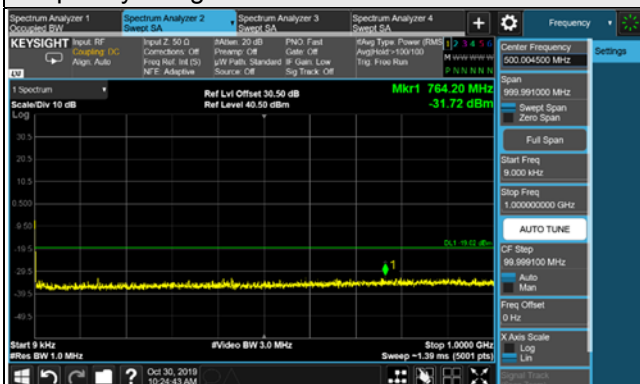

Frequency Range : 1GHz~13GHz



Frequency Range : 13GHz~26GHz

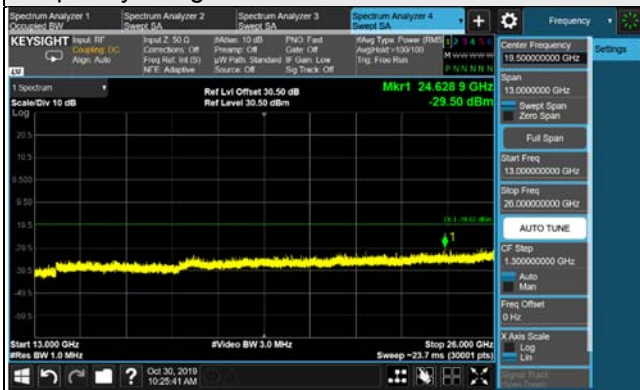

n66, Channel Bandwidth 20MHz, Chain 1

Channel 431000 (2155MHz)

Frequency Range : 9kHz~1GHz

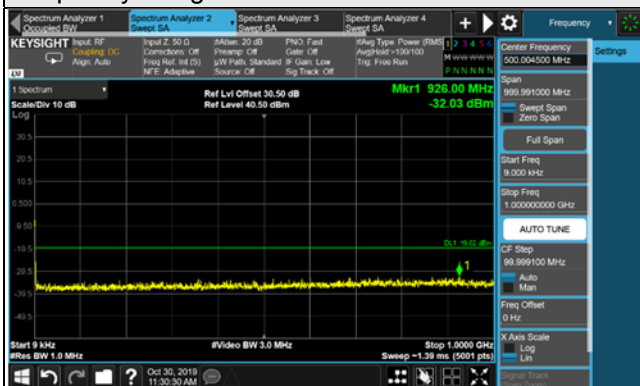

Frequency Range : 1GHz~13GHz

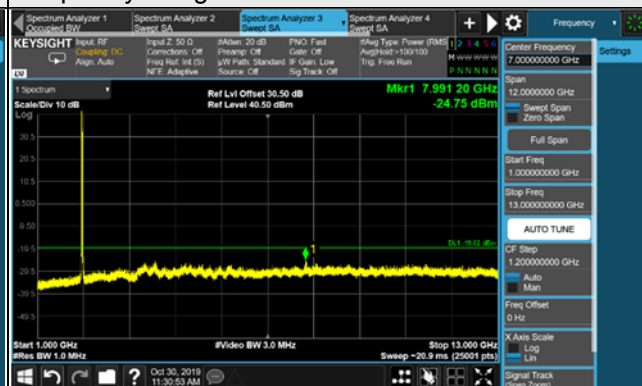

Frequency Range : 13GHz~26GHz



n66, Channel Bandwidth 20MHz, Chain 1

Channel 438000 (2190.0MHz)

Frequency Range : 9kHz~1GHz

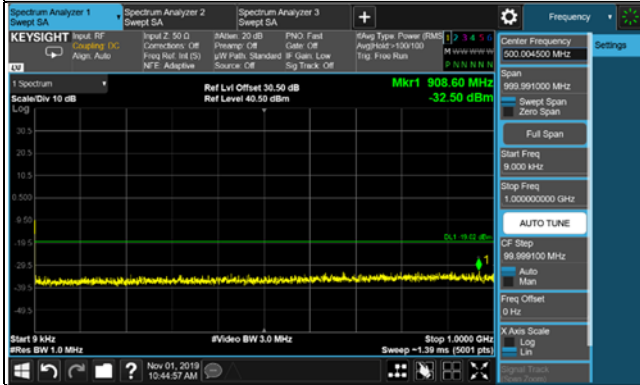

Frequency Range : 1GHz~13GHz



Frequency Range : 13GHz~26GHz



n66, Channel Bandwidth 20MHz, Chain 2

Channel 424000 (2120.0MHz)

Frequency Range : 9kHz~1GHz

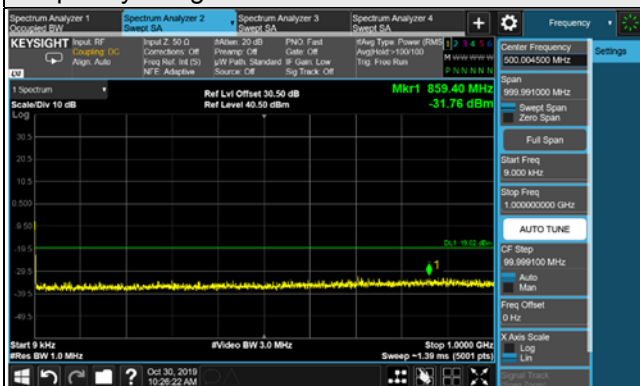

Frequency Range : 1GHz~13GHz



Frequency Range : 13GHz~26GHz

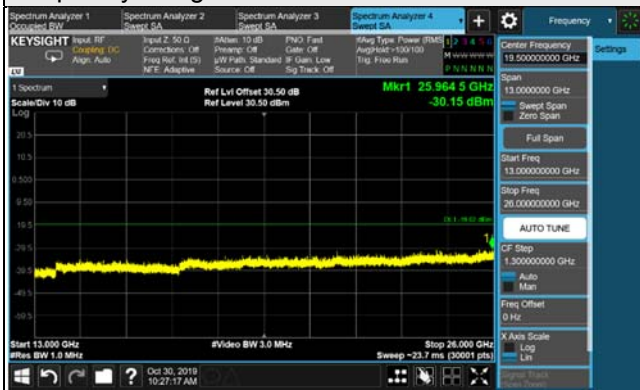

n66, Channel Bandwidth 20MHz, Chain 2

Channel 431000 (2155MHz)

Frequency Range : 9kHz~1GHz

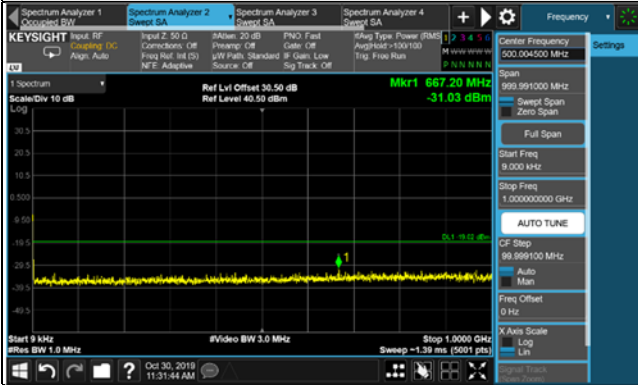

Frequency Range : 1GHz~13GHz

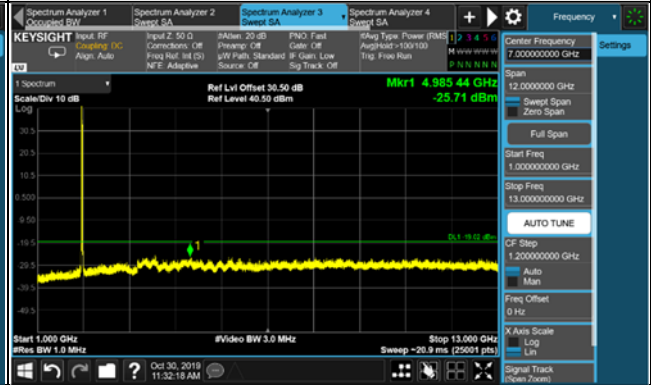

Frequency Range : 13GHz~26GHz

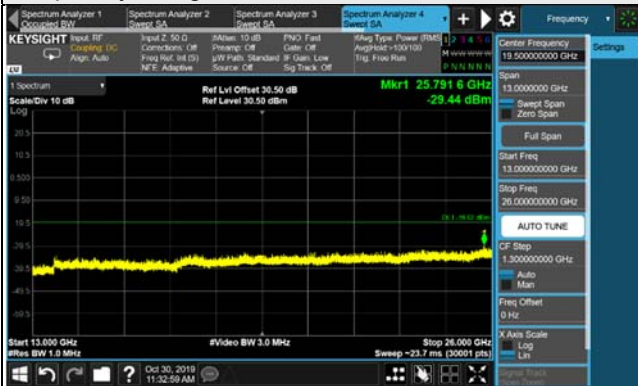

n66, Channel Bandwidth 20MHz, Chain 2

Channel 438000 (2190.0MHz)

Frequency Range : 9kHz~1GHz

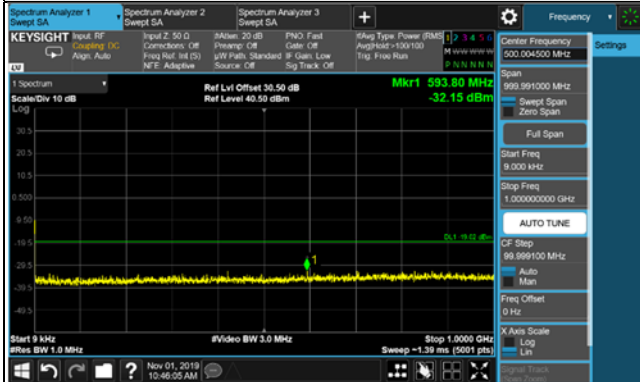

Frequency Range : 1GHz~13GHz

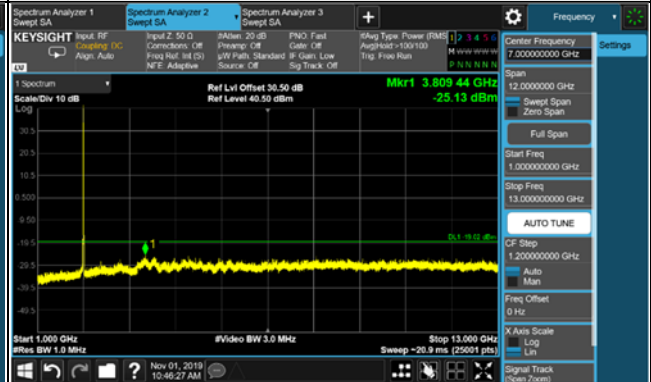

Frequency Range : 13GHz~26GHz

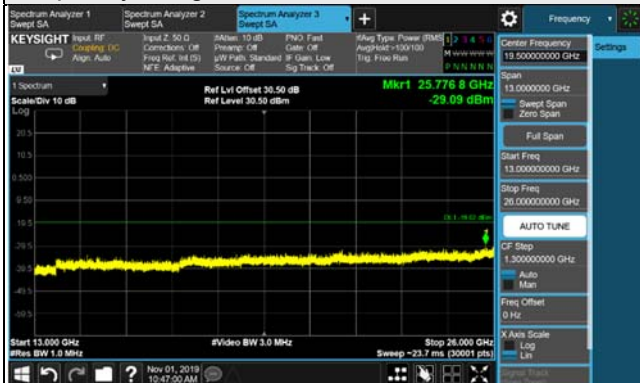

n66, Channel Bandwidth 20MHz, Chain 3

Channel 424000 (2120.0MHz)

Frequency Range : 9kHz~1GHz

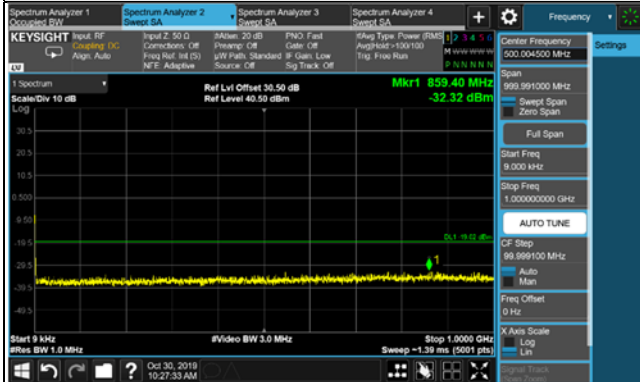

Frequency Range : 1GHz~13GHz

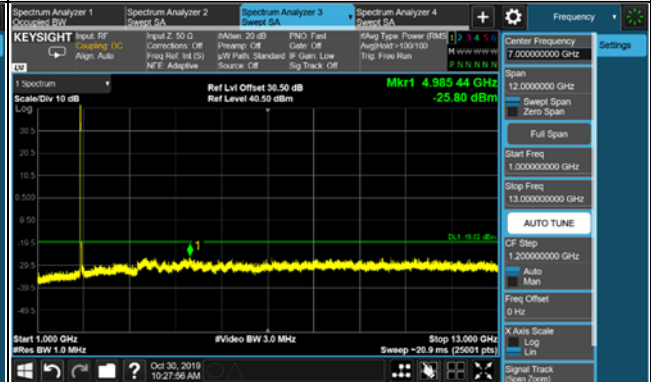

Frequency Range : 13GHz~26GHz

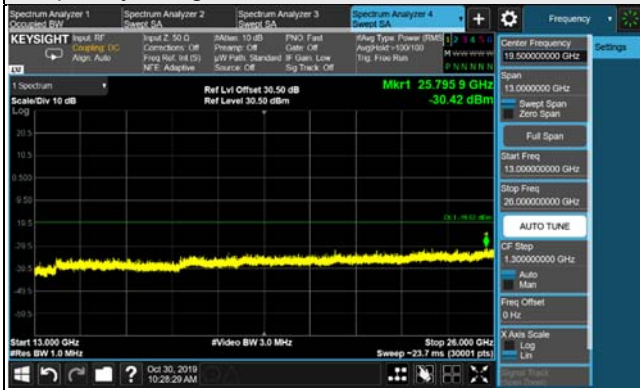



n66, Channel Bandwidth 20MHz, Chain 3

Channel 431000 (2155MHz)

Frequency Range : 9kHz~1GHz

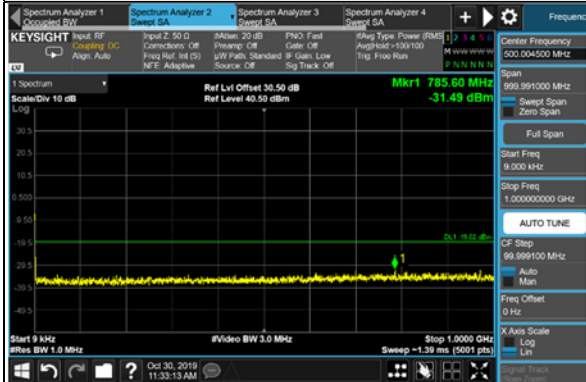

Frequency Range : 1GHz~13GHz



Frequency Range : 13GHz~26GHz

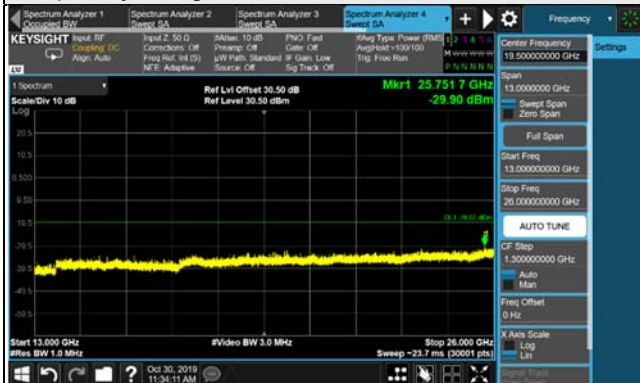

n66, Channel Bandwidth 20MHz, Chain 3

Channel 438000 (2190.0MHz)

Frequency Range : 9kHz~1GHz

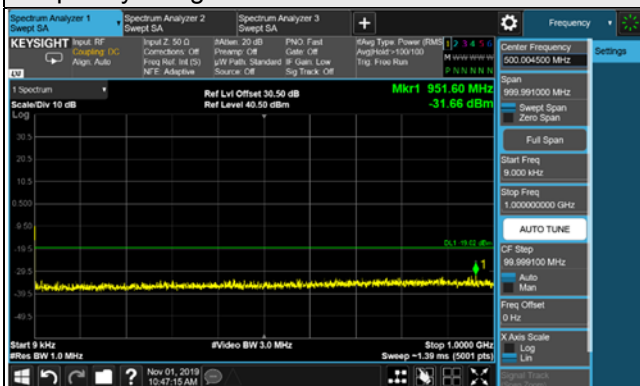

Frequency Range : 1GHz~13GHz



Frequency Range : 13GHz~26GHz



## 4.8 Radiated Emission Measurement

### 4.8.1 Limits of Radiated Emission Measurement

The power of any emission outside of the authorized operating frequency ranges must be attenuated below the transmitting power (P) by a factor of at least  $43 + 10 \log(P)$  dB. The emission limit equal to  $-13\text{dBm}$ .

### 4.8.2 Test Procedure

- a. Substitution method is used for E.I.R.P measurement. In the semi-anechoic chamber, EUT placed on the 0.8m height of Turn Table, rotated the table around 360 degrees to search the maximum radiation power and receiver antenna shall be rotated vertical and horizontal polarization and moved height from 1m to 4m to find the maximum polar radiated power. The "Read Value" is the spectrum reading the maximum power value.
- b. The substitution horn antenna is substituted for EUT at the same position and signals generator export the CW signal to the substitution antenna via a TX cable. Rotated the Turn Table and moved receiving antenna to find the maximum radiation power. Adjust output power level of S.G to get a Value of spectrum reading equal to "Read Value" of step a. Record the power level of S.G
- c.  $\text{EIRP} = \text{Output power level of S.G} - \text{TX cable loss} + \text{Antenna gain of substitution horn.}$
- d. E.R.P power can be calculated form E.I.R.P power by subtracting the gain of dipole,  $\text{E.R.P power} = \text{E.I.R.P power} - 2.15\text{dBi.}$

### 4.8.3 Deviation from Test Standard

No deviation.

#### 4.8.4 Test Setup

For Radiated emission 30MHz to 1GHz

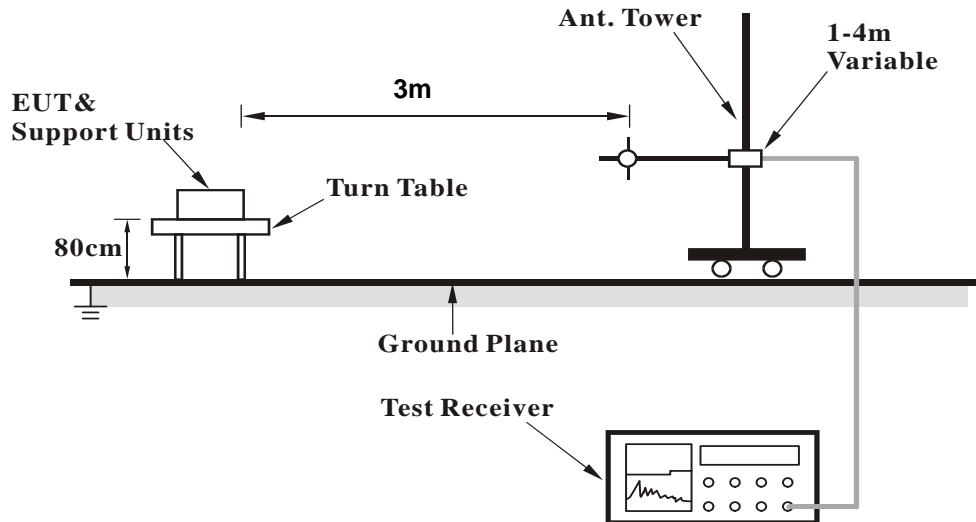

For Radiated emission above 1GHz

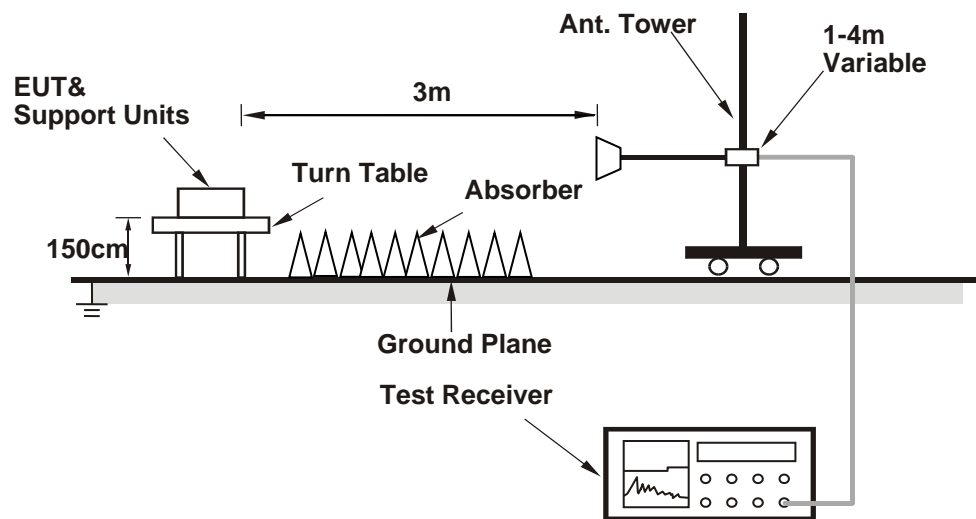

For the actual test configuration, please refer to the attached file (Test Setup Photo).

#### 4.8.5 Test Results

Below 1GHz

n66

Channel Bandwidth: 20MHz

Mode	TX channel 431000 (2155MHz)	Frequency Range	Below 1000 MHz
Environmental Conditions	24deg. C, 68%RH	Input Power	120Vac, 60Hz
Tested By	Greg Lin		

#### Antenna Polarity & Test Distance: Horizontal at 3 M

No.	Freq. (MHz)	Reading (dBm)	S.G Power Value (dBm)	Correction Factor (dB)	EIRP (dBm)	Limit (dBm)	Margin (dB)
1	30.00	-35.7	-12.3	-19.4	-31.7	-13.0	-18.7
2	62.98	-27.5	-31.0	-2.4	-33.4	-13.0	-20.4
3	166.77	-29.5	-33.3	-2.9	-36.2	-13.0	-23.2
4	195.87	-28.8	-34.8	-2.5	-37.3	-13.0	-24.3
5	356.89	-57.5	-64.4	4.0	-60.4	-13.0	-47.4
6	667.29	-61.7	-62.8	3.6	-59.2	-13.0	-46.2

#### Remarks:

1. Output Power (dBm) = S.G Value (dBm) + Correction Factor (dB).
2. Correction Factor (dB) = Substitution Antenna Gain (dB) + Cable Loss (dB).

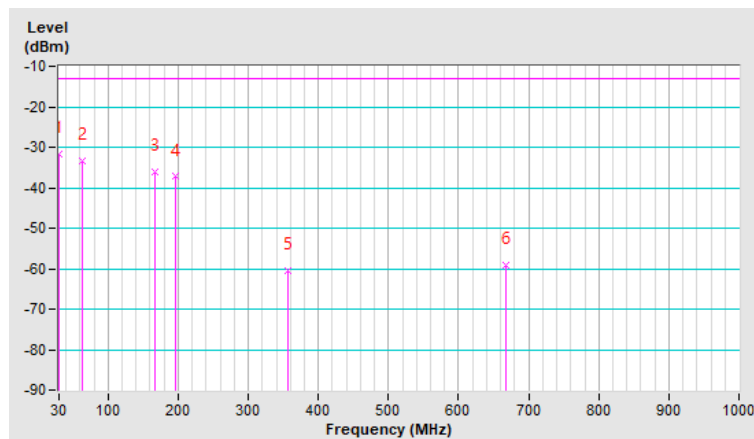

Mode	TX channel 431000 (2155MHz)	Frequency Range	Below 1000 MHz
Environmental Conditions	24deg. C, 68%RH	Input Power	120Vac, 60Hz
Tested By	Greg Lin		

Antenna Polarity & Test Distance: Vertical at 3 M							
No.	Freq. (MHz)	Reading (dBm)	S.G Power Value (dBm)	Correction Factor (dB)	EIRP (dBm)	Limit (dBm)	Margin (dB)
1	31.94	-16.2	-8.4	-18.3	-26.7	-13.0	-13.7
2	67.83	-20.9	-26.8	-1.0	-27.8	-13.0	-14.8
3	146.40	-29.3	-28.3	-3.0	-31.3	-13.0	-18.3
4	175.50	-31.1	-32.0	-2.8	-34.8	-13.0	-21.8
5	370.47	-50.7	-54.9	3.9	-51.0	-13.0	-38.0
6	982.54	-62.1	-56.2	3.5	-52.7	-13.0	-39.7

Remarks:

1. Output Power (dBm) = S.G Value (dBm) + Correction Factor (dB).
2. Correction Factor (dB) = Substitution Antenna Gain (dB) + Cable Loss (dB).

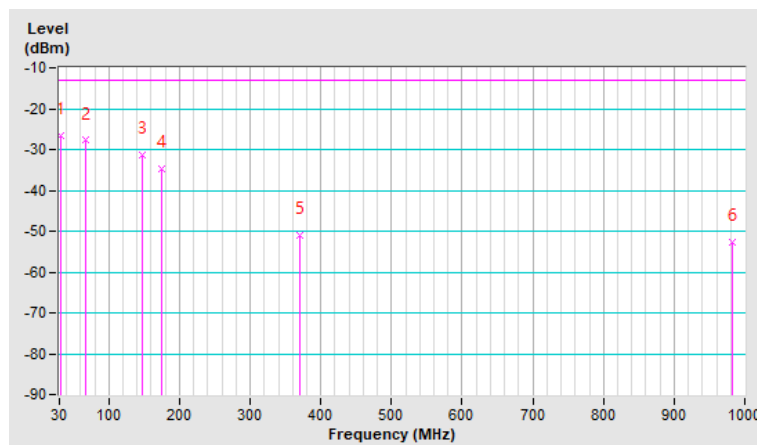

Above 1GHz

n66

Channel Bandwidth: 20MHz

Mode	TX channel 424000 (2120.0MHz)	Frequency Range	1GHz~25GHz
Environmental Conditions	22deg. C, 68%RH	Input Power	120Vac, 60Hz
Tested By	Greg Lin		

Antenna Polarity & Test Distance: Horizontal at 3 M							
No.	Freq. (MHz)	Reading (dBm)	S.G Power Value (dBm)	Correction Factor (dB)	EIRP (dBm)	Limit (dBm)	Margin (dB)
1	4240.00	-55.6	-46.0	1.0	-45.0	-13.0	-32.0
Antenna Polarity & Test Distance: Vertical at 3 M							
No.	Freq. (MHz)	Reading (dBm)	S.G Power Value (dBm)	Correction Factor (dB)	EIRP (dBm)	Limit (dBm)	Margin (dB)
1	4240.00	-54.3	-44.7	1.0	-43.7	-13.0	-30.7

Remarks:

1. Output Power (dBm) = S.G Value (dBm) + Correction Factor (dB).
2. Correction Factor (dB) = Substitution Antenna Gain (dB) + Cable Loss (dB).

Mode	TX channel 431000 (2155MHz)	Frequency Range	1GHz~25GHz
Environmental Conditions	22deg. C, 68%RH	Input Power	120Vac, 60Hz
Tested By	Greg Lin		

Antenna Polarity & Test Distance: Horizontal at 3 M							
No.	Freq. (MHz)	Reading (dBm)	S.G Power Value (dBm)	Correction Factor (dB)	EIRP (dBm)	Limit (dBm)	Margin (dB)
1	4310.00	-55.6	-46.2	1.0	-45.2	-13.0	-32.2
Antenna Polarity & Test Distance: Vertical at 3 M							
No.	Freq. (MHz)	Reading (dBm)	S.G Power Value (dBm)	Correction Factor (dB)	EIRP (dBm)	Limit (dBm)	Margin (dB)
1	4310.00	-53.8	-44.4	1.0	-43.4	-13.0	-30.4

Remarks:

1. Output Power (dBm) = S.G Value (dBm) + Correction Factor (dB).
2. Correction Factor (dB) = Substitution Antenna Gain (dB) + Cable Loss (dB).

Mode	TX channel 438000 (2190.0MHz)	Frequency Range	1GHz~25GHz
Environmental Conditions	22deg. C, 68%RH	Input Power	120Vac, 60Hz
Tested By	Greg Lin		

Antenna Polarity & Test Distance: Horizontal at 3 M							
No.	Freq. (MHz)	Reading (dBm)	S.G Power Value (dBm)	Correction Factor (dB)	EIRP (dBm)	Limit (dBm)	Margin (dB)
1	4380.00	-55.7	-46.4	1.0	-45.4	-13.0	-32.4
Antenna Polarity & Test Distance: Vertical at 3 M							
No.	Freq. (MHz)	Reading (dBm)	S.G Power Value (dBm)	Correction Factor (dB)	EIRP (dBm)	Limit (dBm)	Margin (dB)
1	4380.00	-54.4	-45.1	1.0	-44.1	-13.0	-31.1

Remarks:

1. Output Power (dBm) = S.G Value (dBm) + Correction Factor (dB).
2. Correction Factor (dB) = Substitution Antenna Gain (dB) + Cable Loss (dB).



## 5 Pictures of Test Arrangements

Please refer to the attached file (Test Setup Photo).

## Appendix – Information on the Testing Laboratories

We, Bureau Veritas Consumer Products Services (H.K.) Ltd., Taoyuan Branch, were founded in 1988 to provide our best service in EMC, Radio, Telecom and Safety consultation. Our laboratories are FCC recognized accredited test firms and accredited and approved according to ISO/IEC 17025.

If you have any comments, please feel free to contact us at the following:

### **Linko EMC/RF Lab**

Tel: 886-2-26052180

Fax: 886-2-26051924

### **Hsin Chu EMC/RF/Telecom Lab**

Tel: 886-3-6668565

Fax: 886-3-6668323

### **Hwa Ya EMC/RF/Safety Lab**

Tel: 886-3-3183232

Fax: 886-3-3270892

**Email:** [service.adt@tw.bureauveritas.com](mailto:service.adt@tw.bureauveritas.com)

**Web Site:** [www.bureauveritas-adt.com](http://www.bureauveritas-adt.com)

The address and road map of all our labs can be found in our web site also.

--- END ---