

**Multicarrier Multiband LTE1.4 \_ 16QAM\_ (1930.7, 1932.1 & 2199.3MHz):**

**9kHz to 150kHz**

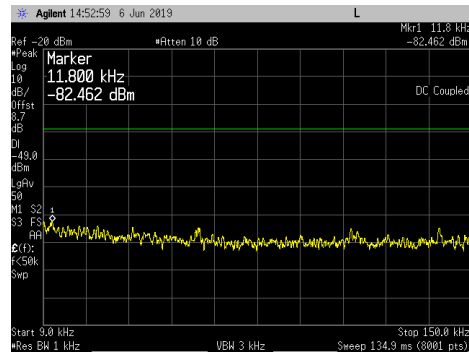

**150kHz to 20MHz**

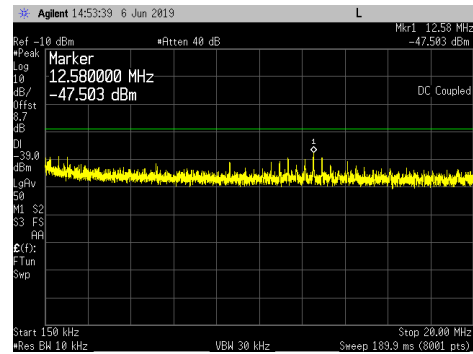

**20MHz to 3GHz**

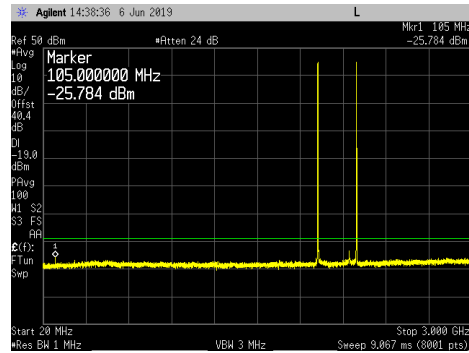

**3GHz to 6GHz**

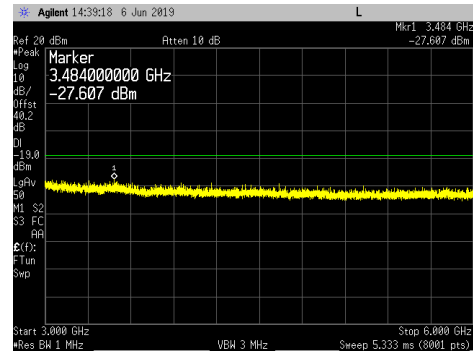

**6GHz to 18GHz**

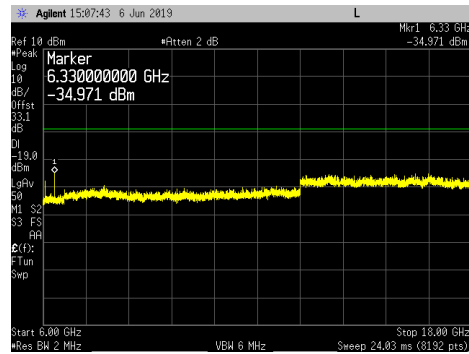

**18GHz to 22GHz**

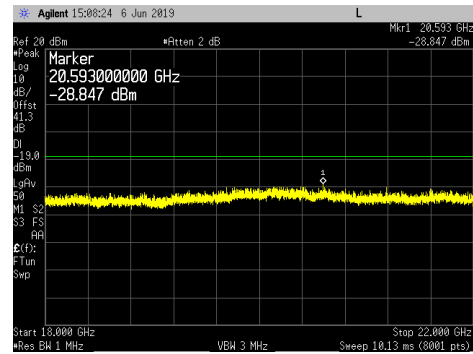

**1900MHz to 2200MHz**

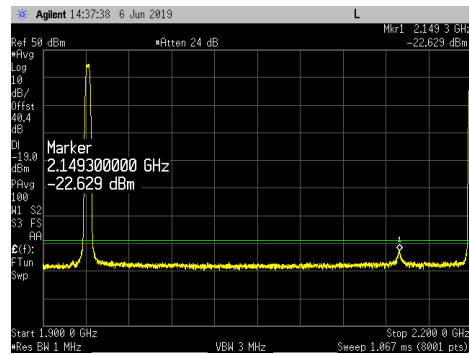

**Multicarrier Multiband LTE1.4 \_ 64QAM\_ (1930.7, 1932.1 & 2199.3MHz):**

**9kHz to 150kHz**

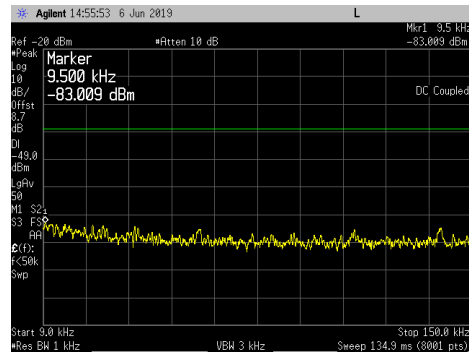

**150kHz to 20MHz**

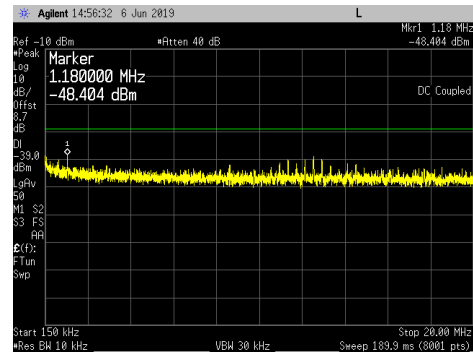

**20MHz to 3GHz**

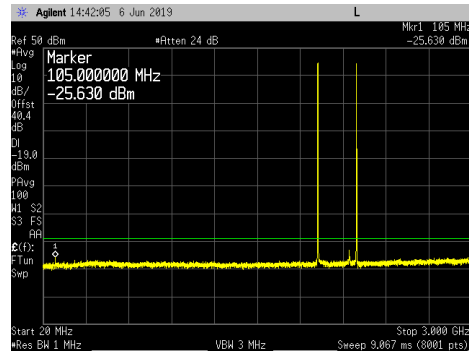

**3GHz to 6GHz**

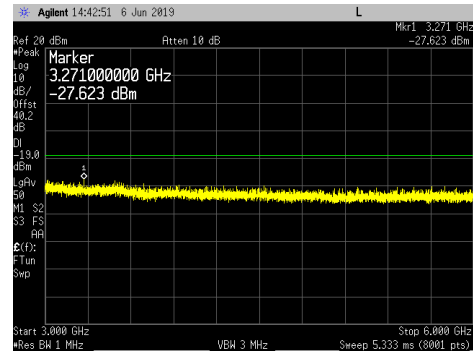

**6GHz to 18GHz**

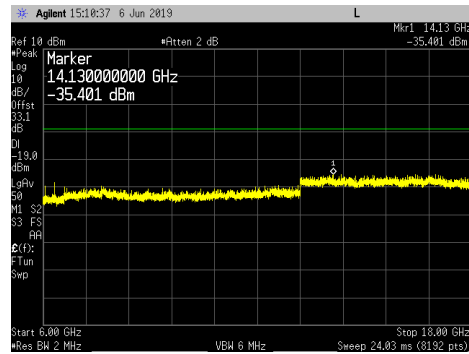

**18GHz to 22GHz**

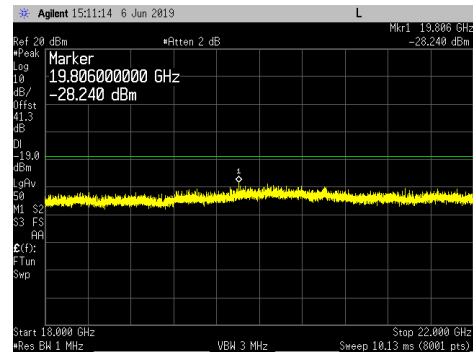

**1900MHz to 2200MHz**

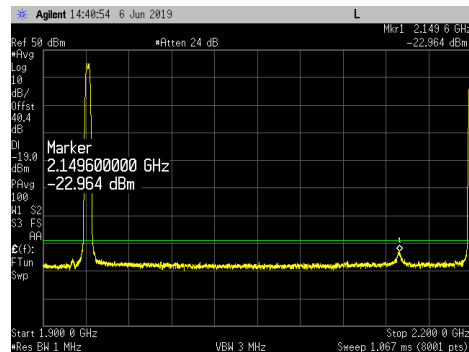

**Multicarrier Multiband LTE1.4 \_ 256QAM\_ (1930.7, 1932.1 & 2199.3MHz):**

**9kHz to 150kHz**

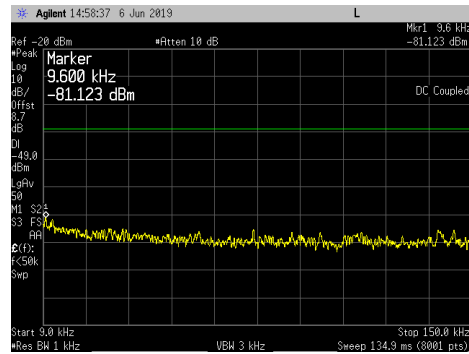

**150kHz to 20MHz**

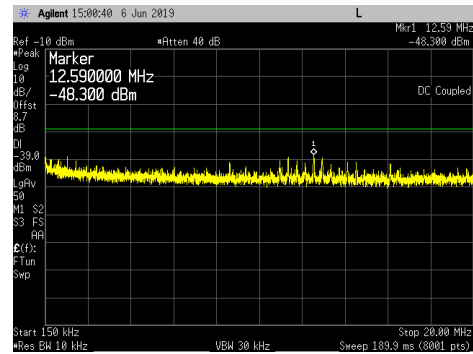

**20MHz to 3GHz**

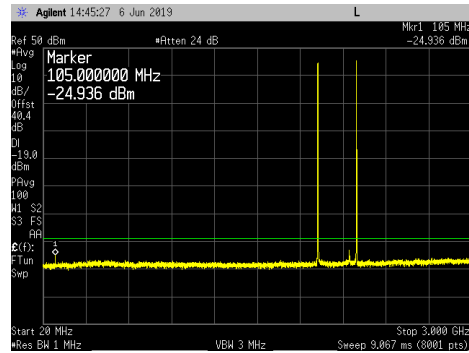

**3GHz to 6GHz**

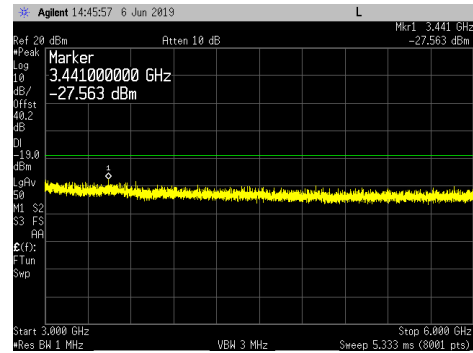

**6GHz to 18GHz**

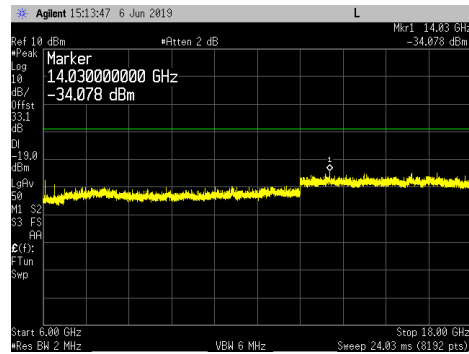

**18GHz to 22GHz**

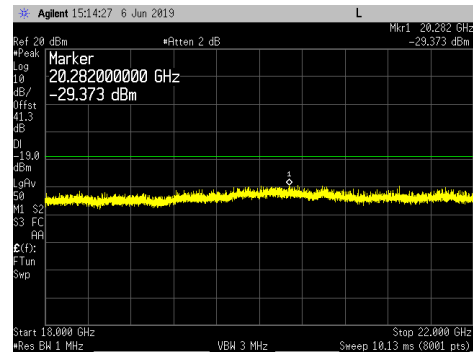

**1900MHz to 2200MHz**

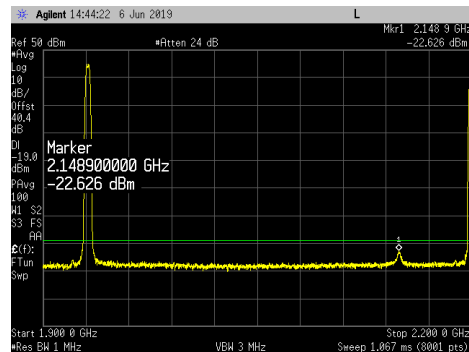

### Transmitter Radiated Spurious Emissions

During radiated emission testing all antenna ports of the base station were terminated with 50ohm termination blocks as shown in the diagram below.

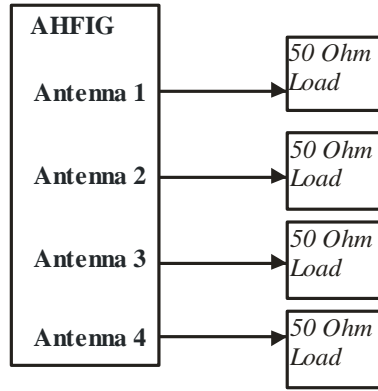

See ANSI C63.26-2015 paragraph 5.1 for details of test setup requirements. Based on antenna port conducted spurious emissions tests results, preliminary scans for radiated spurious emissions were performed in 30MHz – 22GHz frequency range. One radiated emission test configuration was used to prove compliance for both the AWS and PCS frequency bands. The 3GPP Band 25 and the 3GPP Band 66 transmitters were enabled simultaneously at maximum power using QPSK modulation on all four ports for this test. The test includes channel bandwidth with the highest spectral density (LTE1.4) for both frequency bands . The bottom, middle and top frequency channels for each band were enabled. The carrier configuration for the radiated emission testing is provided below. Final maximized peak radiated emissions were measured in these modes.

Frequency Band	Antenna Port	RF Bandwidth	EARFCN	Transmit Frequency
PCS	1	1.4 MHz	8047 (Bottom Channel)	1930.7 MHz
PCS	2	1.4 MHz	8365 (Middle Channel)	1962.5 MHz
PCS	3	1.4 MHz	8633 (Top Channel)	1989.3 MHz
PCS	4	5 MHz	8665 (Top Channel)	1992.5 MHz
AWS	1	1.4 MHz	66443 (Bottom Channel)	2110.7 MHz
AWS	2	1.4 MHz	66886 (Middle Channel)	2155.0 MHz
AWS	3	1.4 MHz	66886 (Middle Channel)	2155.0 MHz
AWS	4	1.4 MHz	67329 (Top Channel)	2199.3 MHz



#### **RE Data**

A three-meter measurement distance was used for radiated emission less than 10GHz. A one-meter measurement distance was used for radiated emission greater than 10GHz. The highest radiated emissions detected were more than 20dB below the three-meter limit of 82.2dBuV/m and the one-meter limit of 91.7dBuV/m (equivalent to -13dBm EIRP). Since all maximized measurements were more than 20dB below these levels, substitution measurements were not performed. TILE software was used for all preliminary scans and plots that are included on the following pages.



Frequency MHz	Peaks Raw dBuV/m	Antenna dB	Pre Amp dB	Cables dB	Peaks dBuV/m	Limit dBuV/m	Margin dB	Tower cm	Turntable Degrees	Polarity H/V
17996.50	28.880	47.563	-30.133	9.102	55.412	91.7	-36.288	100	359	H
17847.70	26.774	47.154	-30.038	8.428	52.318	91.7	-39.382	100	359	H
17972.30	25.082	47.660	-30.22	8.993	51.515	91.7	-40.185	100	359	V
17993.80	24.964	47.574	-30.142	9.09	51.486	91.7	-40.214	100	359	V
17964.90	24.232	47.689	-30.246	8.959	50.634	91.7	-41.066	100	359	V
17867.10	24.857	47.177	-30.098	8.516	50.452	91.7	-41.248	100	359	H
17787.00	23.943	46.876	-30.057	8.153	48.915	91.7	-42.785	100	359	H
17971.00	21.851	47.665	-30.224	8.986	48.278	91.7	-43.422	100	359	H
19660.90	41.946	44.893	-50.8	11.692	47.731	91.7	-43.969	100	187	V
21349.80	41.350	45.130	-51.13	12.357	47.707	91.7	-43.993	100	359	V
17945.90	20.056	47.705	-30.293	8.873	46.341	91.7	-45.359	100	359	V
17897.50	20.049	47.198	-30.201	8.654	45.700	91.7	-46.000	100	359	V
18208.30	38.288	45.016	-50.509	11.135	43.930	91.7	-47.770	100	359	H
18811.10	37.702	44.762	-50.502	11.177	43.139	91.7	-48.561	100	359	H
17874.30	16.054	47.182	-30.123	8.548	41.661	91.7	-50.039	100	359	V
4398.10	35.738	32.212	-32.292	5.342	41.000	82.2	-41.200	300	67	H
4310.36	35.628	32.129	-32.338	5.289	40.708	82.2	-41.492	300	359	H
20380.80	33.856	44.663	-50.785	11.862	39.596	91.7	-52.104	100	359	H
20323.40	33.737	44.658	-50.859	11.876	39.412	91.7	-52.288	100	359	V
18964.00	31.552	44.916	-50.594	11.187	37.061	91.7	-54.639	100	359	H
8811.28	27.760	37.679	-32.585	3.895	36.749	82.2	-45.451	300	359	V
18189.60	30.653	45.045	-50.515	11.133	36.316	91.7	-55.384	100	1	V
6901.51	26.790	35.212	-32.299	6.493	36.196	82.2	-46.004	300	359	V
4398.47	30.687	32.213	-32.291	5.342	35.951	82.2	-46.249	300	359	V
20326.60	29.794	44.658	-50.855	11.875	35.472	91.7	-56.228	100	359	V
20810.70	28.859	45.017	-51.183	11.764	34.457	91.7	-57.243	100	359	V
17874.80	8.535	47.182	-30.124	8.551	34.144	91.7	-57.556	128	359	H
21915.10	26.514	45.175	-51.345	13.385	33.729	91.7	-57.971	100	359	H
929.65	40.697	23.835	-34.3	2.968	33.200	82.2	-49.000	178	306	H
21264.00	26.591	45.138	-51.201	12.2	32.728	91.7	-58.972	100	359	H
4077.28	27.615	32.257	-32.412	5.064	32.524	82.2	-49.676	300	359	H
6465.48	23.497	34.292	-32.336	6.203	31.656	82.2	-50.544	300	1	H
937.50	38.788	23.800	-34.3	2.952	31.240	82.2	-50.960	175	198	V
937.50	37.674	23.8	-34.3	2.952	30.126	82.2	-52.074	165	45	H
1868.84	27.908	27.241	-34.693	8.811	29.267	82.2	-52.933	300	359	H
812.50	37.923	22.400	-34.5	2.731	28.554	82.2	-53.646	107	13	H
812.52	35.919	22.4	-34.5	2.731	26.550	82.2	-55.650	115	38	V
4310.90	21.293	32.129	-32.338	5.289	26.373	82.2	-55.827	200	359	V
8334.47	15.673	37.079	-32.5	5.431	25.683	82.2	-56.517	300	359	V
2245.84	27.798	27.569	-34.328	4.43	25.469	82.2	-56.731	300	359	H
749.36	35.290	21.4	-34.486	2.462	24.666	82.2	-57.534	100	151	H
1844.56	23.933	27.092	-34.738	7.97	24.257	82.2	-57.943	100	359	V
687.47	33.180	21.500	-34.45	2.273	22.503	82.2	-59.697	100	278	V
755.22	29.636	21.722	-34.495	2.488	19.351	82.2	-62.849	100	1	H
929.713	23.305	23.829	-34.3	2.968	15.802	82.2	-66.398	229	1	V
746.94	19.576	21.300	-34.483	2.451	8.844	82.2	-73.356	100	128	V

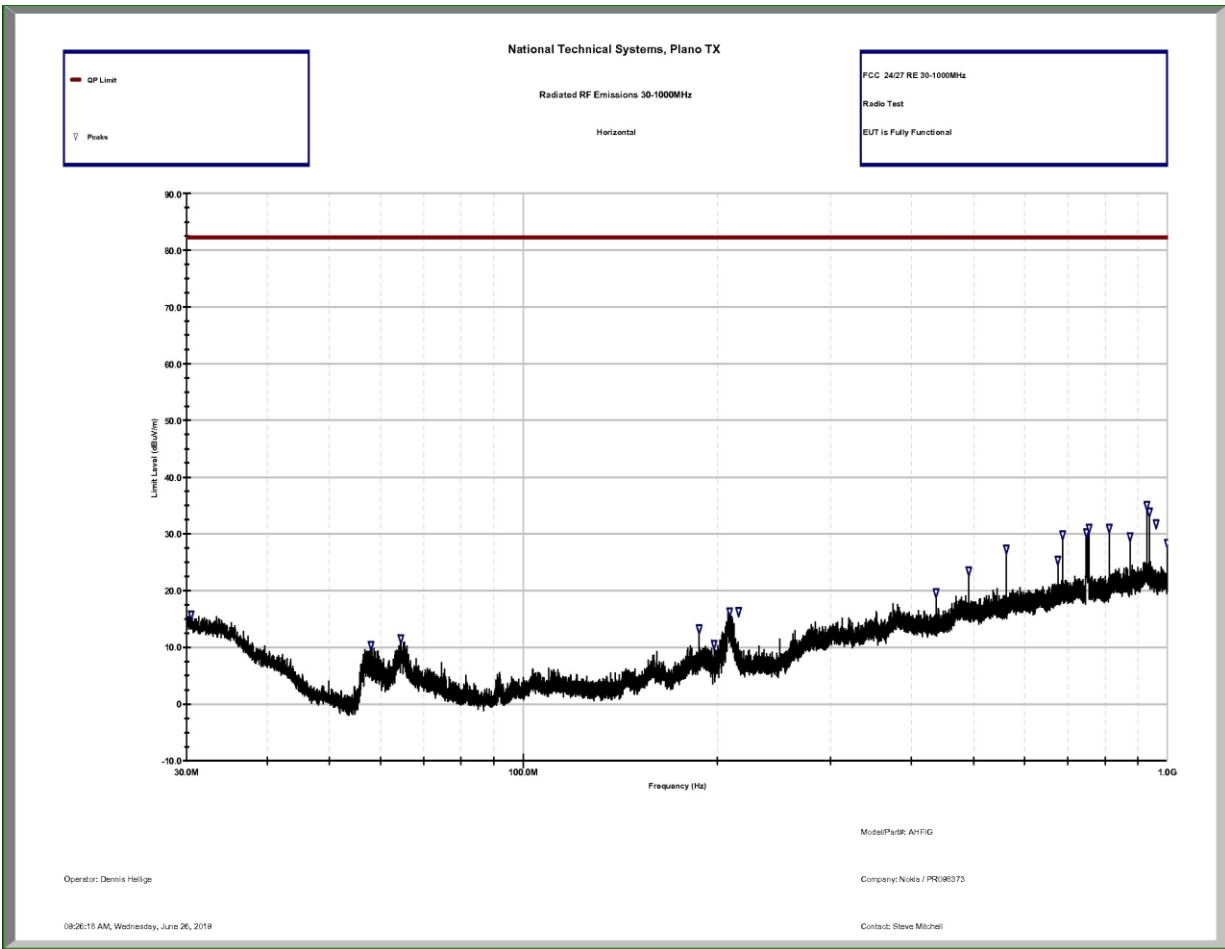

RE 30-1000MHz Radio Test Horizontal Graph (3 meter test distance)

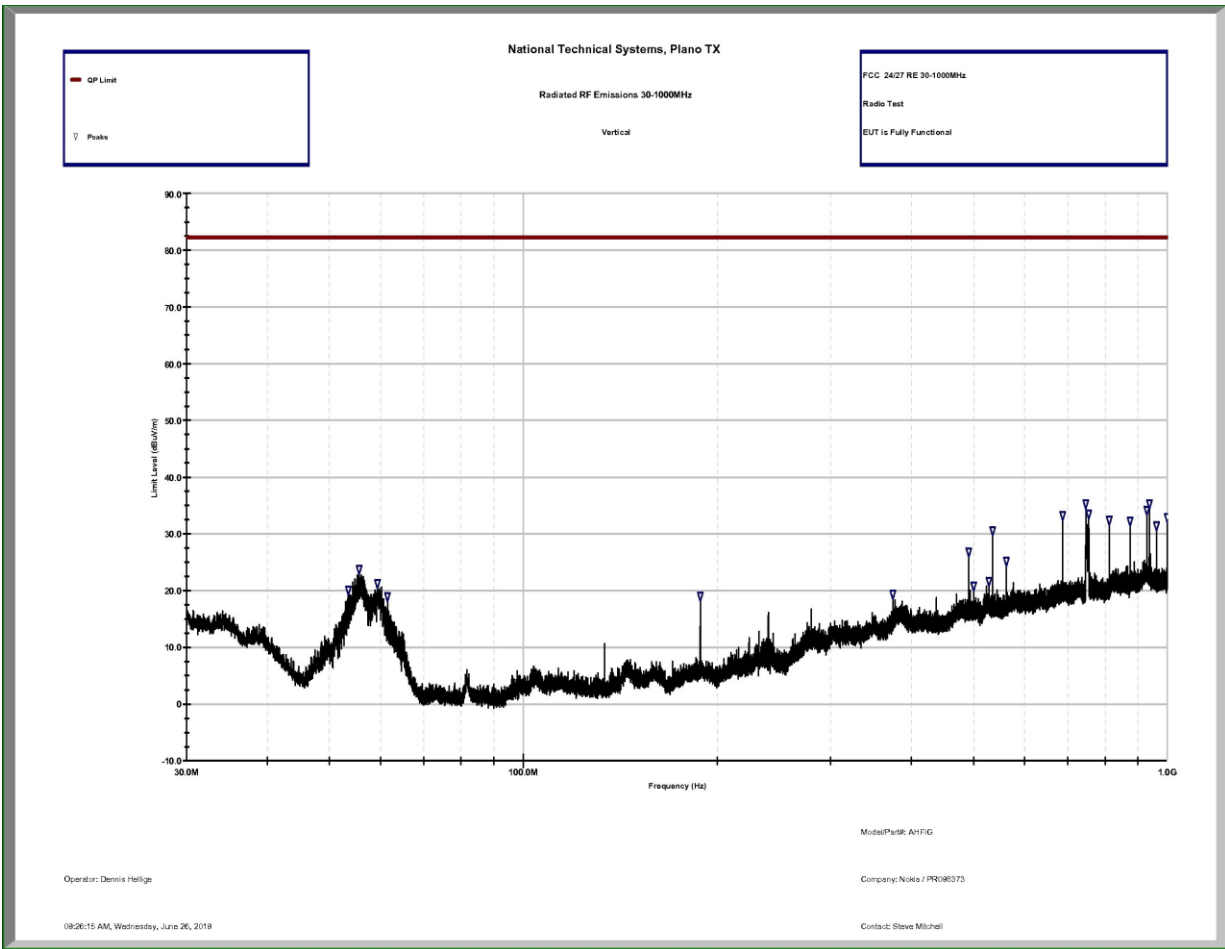

RE 30-1000MHz Radio Test Vertical Graph (3 meter test distance)



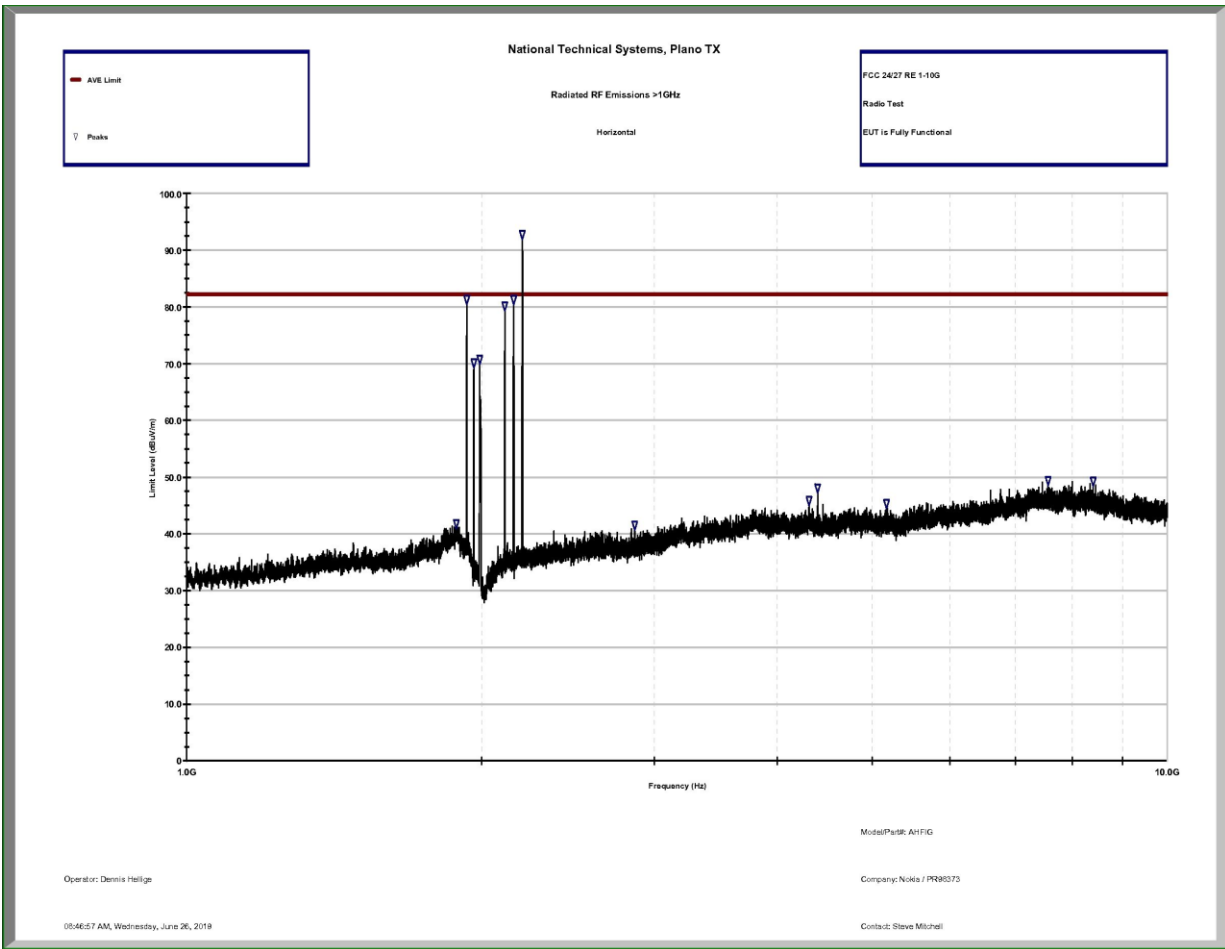

RE 1-10GHz Radio Test Horizontal Graph (3 meter test distance)

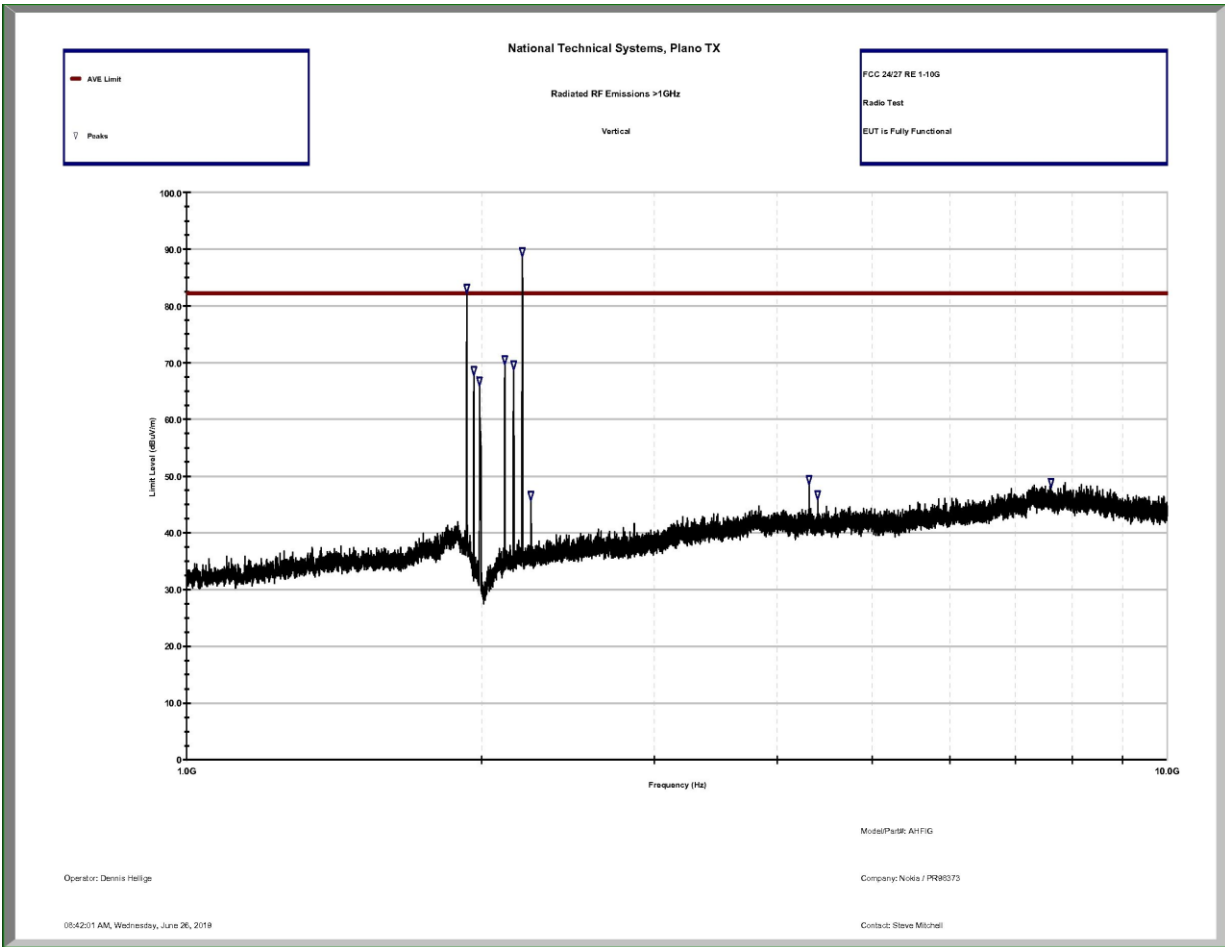

RE 1-10GHz Radio Test Vertical Graph (3 meter test distance)

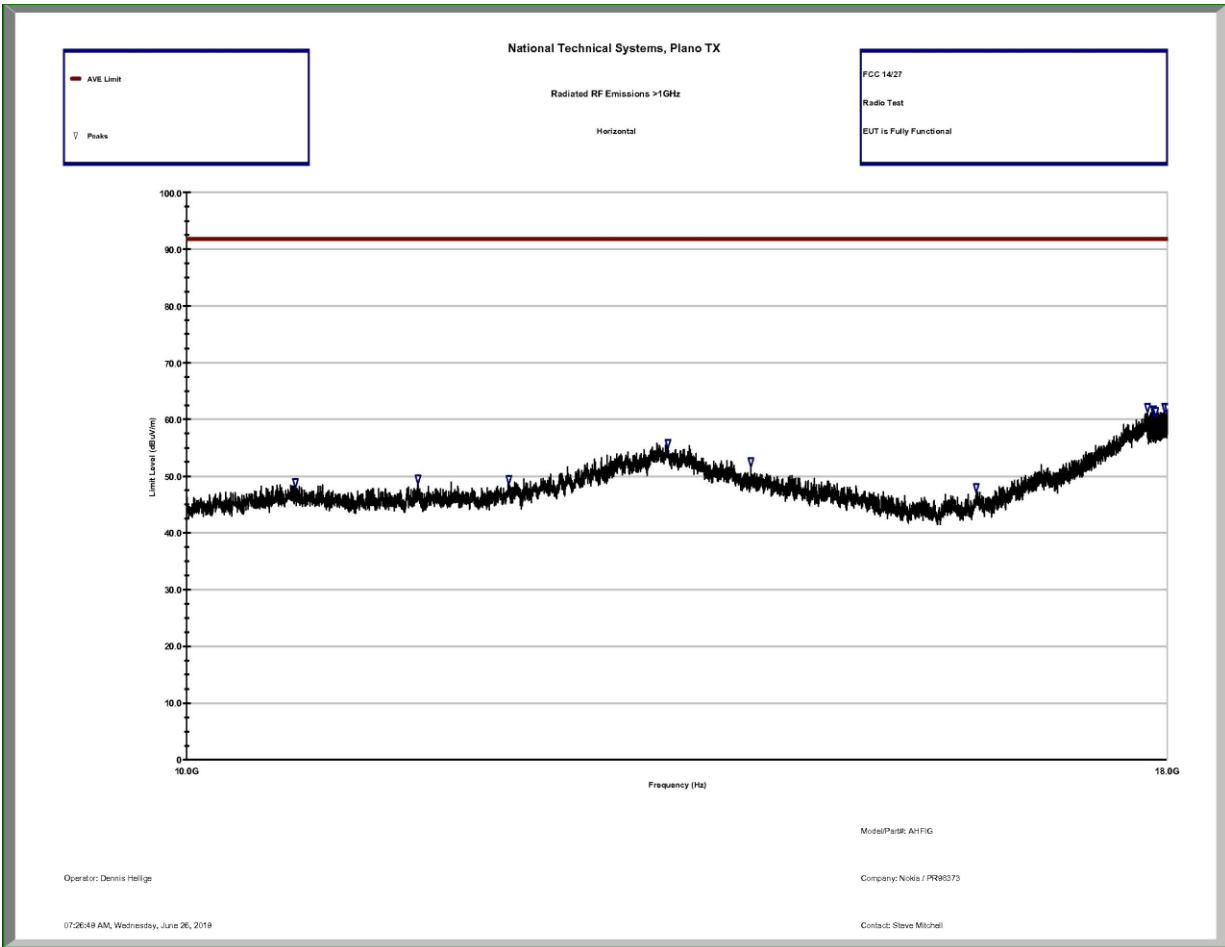

RE 10-18GHz Radio Test Horizontal Graph (1 meter test distance)

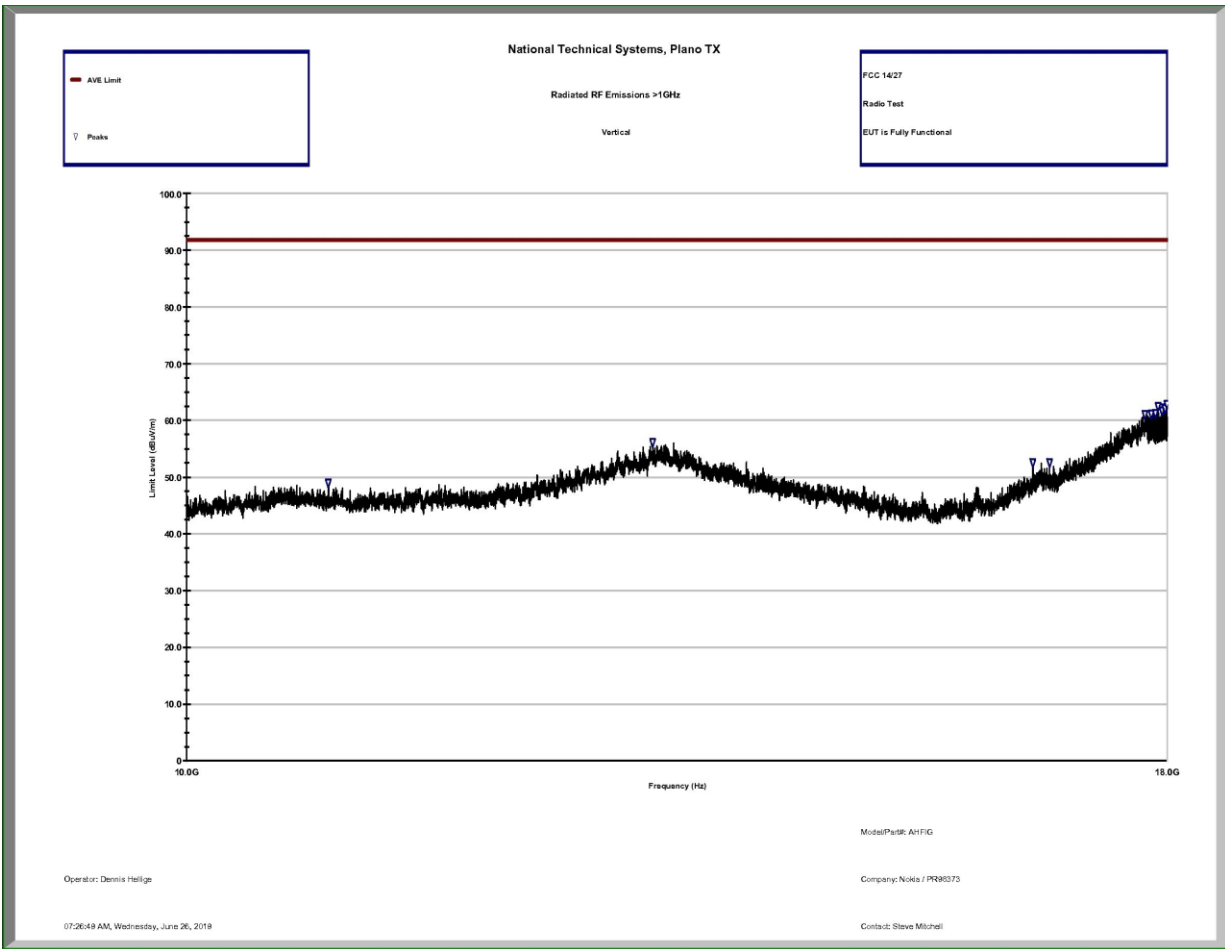

RE 10-18GHz Radio Test Vertical Graph (1 meter test distance)

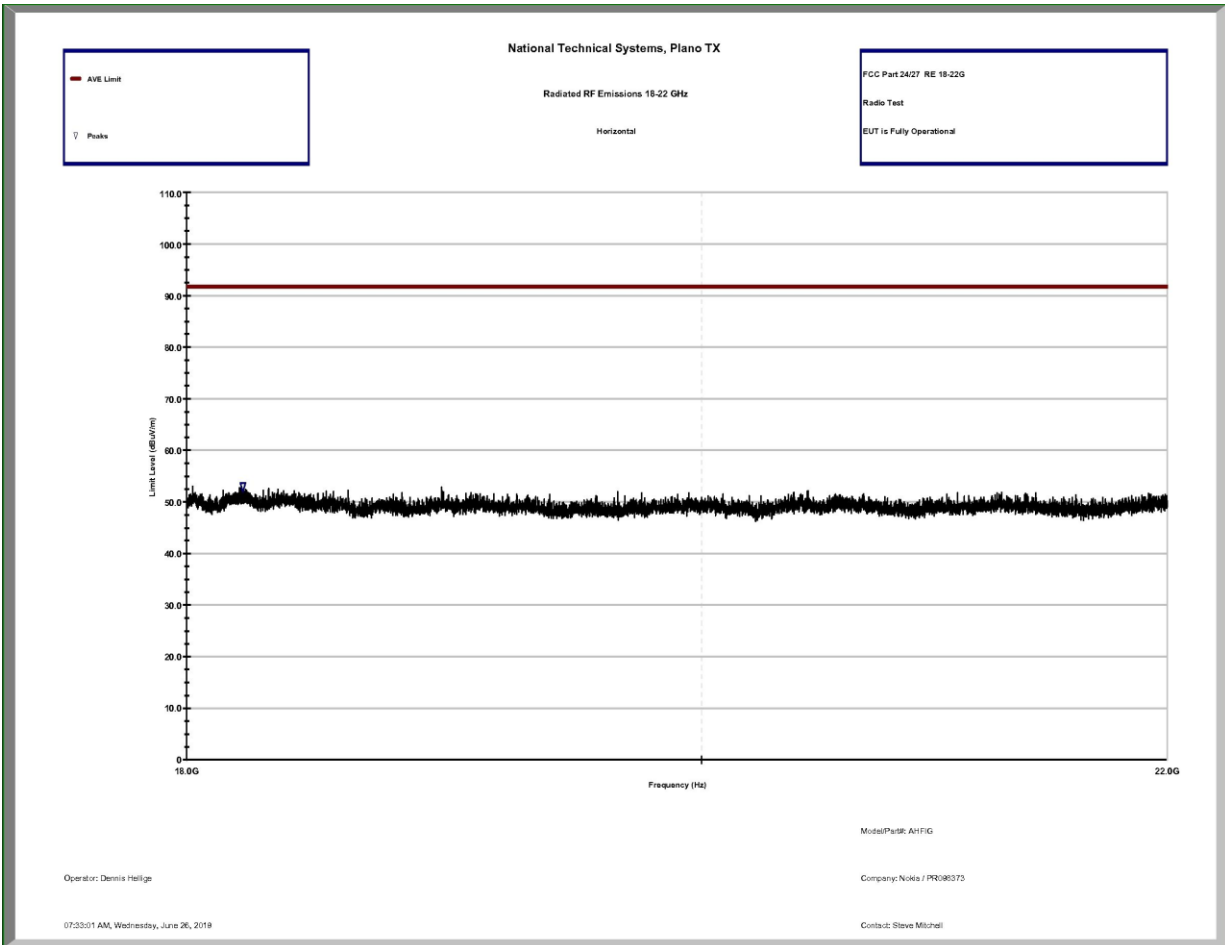

RE 18-22GHz Radio Test Horizontal Graph (1 meter test distance)

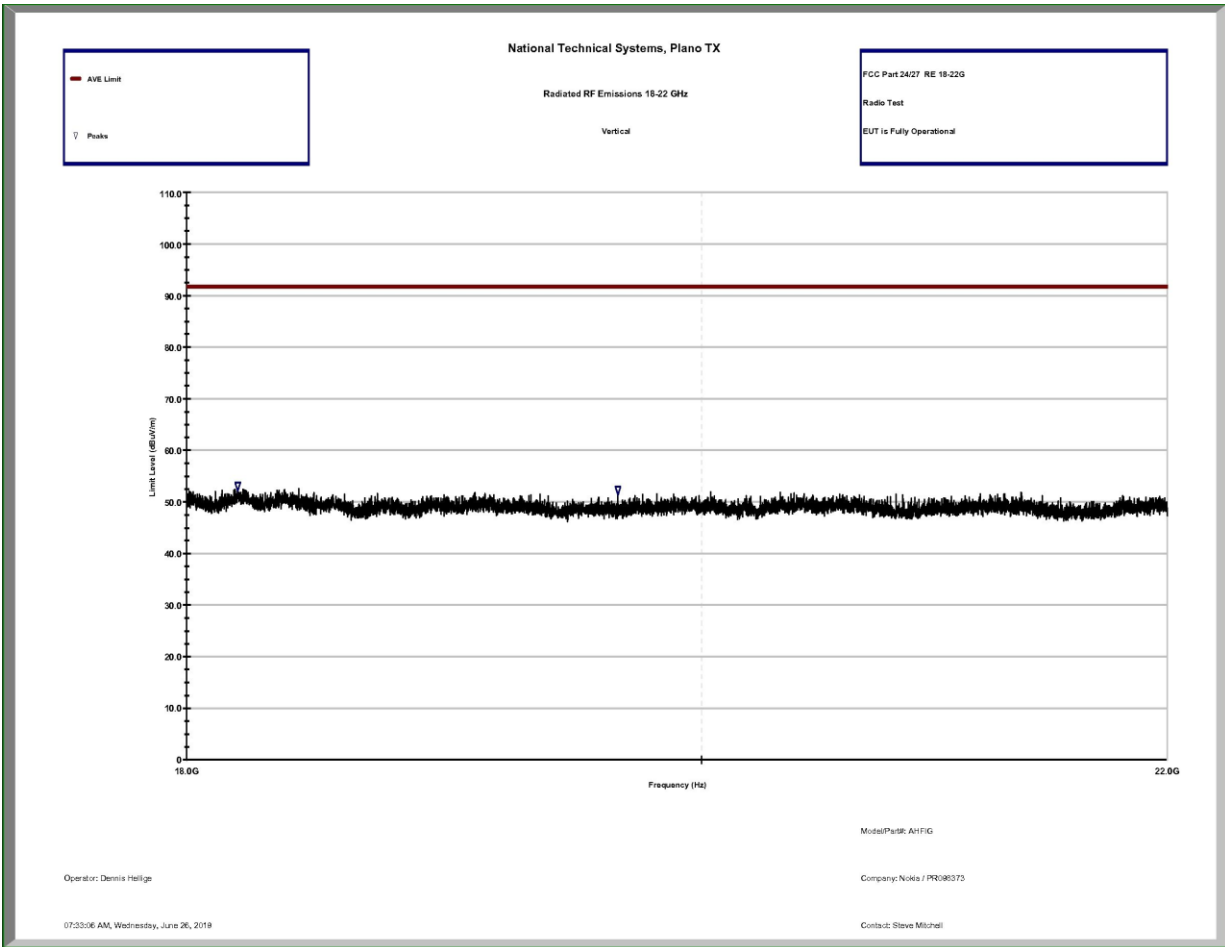

RE 18-22GHz Radio Test Vertical Graph (1 meter test distance)

### Frequency Stability/Accuracy

Carrier frequency stability at extreme temperatures and voltages, frequency error was measured as follows:

- (1) Transmitting in 5MHz-QPSK-LTE mode at PCS center channel (1962.5MHz) and AWS center channel (2155MHz) on port 3.
- (2) Transmitting in QPSK-WCDMA mode at PCS channel 9750 (1950.0MHz) and AWS center channel (2140MHz) on port 2.
- (3) Transmitting in GMSK - GSM mode at PCS channel 711 (1970.0MHz) on port 1.
- (4) The EUT temperature was stabilized at each temperature step (for a minimum of 30 minutes) prior to frequency accuracy measurement.

Nominal operating voltage of the product is declared as 48VDC. Frequency error results are listed below for extreme voltages and temperatures.

#### Extreme Voltages:

Percentage of Rated Supply	DC Voltage (VDC)	Frequency Error (Hz) at 20°C				
		PCS 1962.5MHz LTE5	AWS 2155.0MHz LTE5	PCS 1950.0MHz WCDMA	AWS 2140.0MHz WCDMA	PCS 1970.0MHz GMSK
85%	40.8	1.21 Hz	1.15 Hz	2.71 Hz	2.95 Hz	2.80 Hz
100%	48.0	1.57 Hz	1.59 Hz	2.62 Hz	2.79 Hz	3.14 Hz
115%	55.2	1.32 Hz	1.42 Hz	2.44 Hz	3.54 Hz	2.84 Hz

#### Extreme Temperatures:

Temperature	Frequency Error (Hz) at 48VDC				
	PCS 1962.5MHz LTE5	AWS 2155.0MHz LTE5	PCS 1950.0MHz WCDMA	AWS 2140.0MHz WCDMA	PCS 1970.0MHz GMSK
-30 °C	1.34 Hz	1.53 Hz	2.66 Hz	3.11 Hz	3.11 Hz
-20 °C	1.35 Hz	1.54 Hz	2.57 Hz	2.94 Hz	2.73 Hz
-10 °C	1.19 Hz	1.49 Hz	3.45 Hz	3.47 Hz	3.78 Hz
0 °C	<b>1.72 Hz</b>	1.75 Hz	<b>4.36 Hz</b>	<b>4.5 Hz</b>	<b>3.96 Hz</b>
10 °C	1.26 Hz	<b>1.81 Hz</b>	2.65 Hz	2.75 Hz	2.7 Hz
20 °C	1.57 Hz	1.59 Hz	2.62 Hz	2.79 Hz	3.14 Hz
30 °C	1.26 Hz	1.75 Hz	3.37 Hz	2.95 Hz	3.28 Hz
40 °C	1.39 Hz	1.58 Hz	2.98 Hz	3.17 Hz	2.84 Hz
50 °C	1.34 Hz	1.60 Hz	2.78 Hz	2.91 Hz	3.12 Hz

**Test Summary:**

<b>Worst Case Frequency Error</b>					
<b>Measurement Parameter</b>	<b>PCS 1962.5MHz LTE5</b>	<b>AWS 2155.0MHz LTE5</b>	<b>PCS 1950.0MHz WCDMA</b>	<b>AWS 2140.0MHz WCDMA</b>	<b>PCS 1970.0MHz GMSK</b>
Hertz	1.72 Hz	1.81 Hz	4.36 Hz	4.50 Hz	3.96 Hz
Parts Per Million	0.0009 PPM	0.0008 PPM	0.0022 PPM	0.0021 PPM	0.0020 PPM

The highest frequency error for each test case (radio technology-frequency band) is highlighted. Based on the results above, the highest recorded frequency error (4.36 Hz or 0.002 PPM) ensures that the transmitted signal remains in its authorized frequency block at extreme voltages and temperatures. The results above are deemed sufficient to demonstrate carrier frequency stability for all other channel bandwidth modes and modulations since all carriers are controlled by the same frequency stabilization circuitry that was subjected to the extreme conditions under this test.



### APPENDIX B: ANTENNA PORT LTE TEST DATA FOR THE AWS BAND

All conducted RF measurements in this section were made at AHFIG antenna ports. All available LTE channel bandwidths (1.4, 3, 5, 10, 15 & 20MHz) with all available modulation types (QPSK, 16QAM, 64QAM & 256QAM) were measured. The LTE modulation types are setup according to 3GPP TS 36.141 E-UTRA Test Models (E-TM) as follows E-TM 1.1: QPSK, E-TM 3.1: 64QAM, E-TM3.1a: 256QAM and E-TM 3.2: 16QAM. The test setup used is provided below.

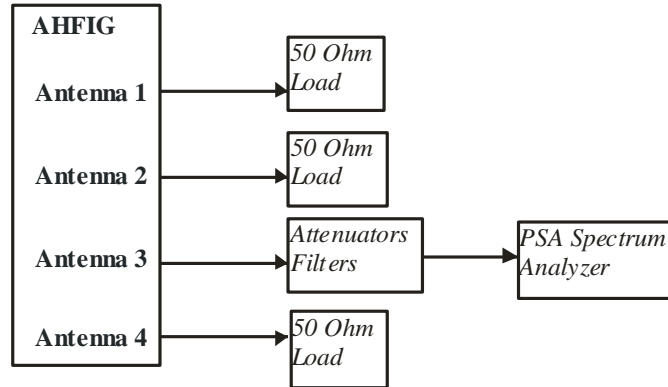

Test Setup Used for AHFIG Conducted RF Measurements

### RF Output Power

RF output power has been measured in RMS Average terms for each AWS transmit chain at the middle channel (2155.0MHz) for 256QAM modulation and LTE5 bandwidth as described in section 5.2 of KDB 971168 D01v03r01 and ANSI C63.26-2015 section 5.2.4.4. The RRH was operated at maximum RF output power. The peak to average power ratio (PAPR) has been measured using the signal analyzer complementary cumulative distribution function (CCDF) for a probability of 0.1% as described in section 5.7.2 of KDB971168 D01v03r01 and ANSI C63.26-2015 section 5.2.3.4. All results are presented in tabular form below. The highest measured values are highlighted.

Antenna	LTE Bandwidth	LTE - 256QAM	
		PAPR (dB)	Average (dBm)
Port 1 Middle Channel	5M	7.26	45.90
Port 2 Middle Channel	5M	7.26	45.87
Port 3 Middle Channel	5M	7.24	45.98
Port 4 Middle Channel	5M	7.23	45.96

The variation in RMS output power levels between the antenna ports is 0.11 dB per data sample provided above. Pre-compliance testing (and testing of similar EUTs) shows that the output power variation between antenna ports is small (the output ports are essentially electrically identical). The highest power port was selected as the worst case.

Pre-compliance testing has shown that the output power variation between modulation types is small. Antenna port 3 power output measurements for the LTE5 bandwidth for all modulation types on the middle (center) channel are provided below.

	Modulation Type							
	QPSK		16QAM		64QAM		256QAM	
	PAPR (dB)	Ave (dBm)	PAPR (dB)	Ave (dBm)	PAPR (dB)	Ave (dBm)	PAPR (dB)	Ave (dBm)
Antenna Port 3 Middle Channel LTE5	7.25	46.01	7.25	46.03	7.21	46.06	7.24	45.98

The output power variation between modulation types is small in this measurement snapshot (and from past efforts on similar hardware as well). The variation of average power output versus modulation type is 0.08dB for the data snapshot provided. The variation of PAPR versus modulation type is 0.04dB for the data snapshot provided. All power measurements in this report (except the sample test noted above) were performed with the EUT operating with 256QAM modulation.

Based on the results above, Port 3 had the highest LTE RMS average power for the AWS band (represents the worst case) and therefore it was selected for all the remaining antenna port tests. Port 3 has the highest combined LTE RMS average power for the AWS + PCS bands. Subsequently output power levels on bottom, middle, and top channels in all 6 LTE channel bandwidths and 256QAM modulation type were tested only at Port 3 and the results presented below. The highest measured values are highlighted.

Antenna LTE Channel	LTE Bandwidth	LTE - 256QAM	
		PAPR (dB)	Average (dBm)
Port 3 Bottom Channel	1.4M	7.28	45.88
	3M	7.24	45.91
	5M	7.26	45.90
	10M	7.25	46.13
	15M	7.25	46.17
	20M	7.24	46.15
Port 3 Middle Channel	1.4M	7.22	45.82
	3M	7.25	45.89
	5M	7.25	46.03
	10M	7.24	45.96
	15M	7.21	45.93
	20M	7.19	45.86
Port 3 Top Channel	1.4M	7.26	45.88
	3M	7.23	45.85
	5M	7.26	46.06
	10M	7.27	46.02
	15M	7.26	46.08
	20M	7.25	46.15

The data provided in the table shows (and testing of similar EUTs) that the output RMS power variation between channel bandwidths at the center frequency channel is small (0.21dB).

RF output power has been measured in RMS Average terms for each AWS multicarrier test configuration to verify/document the power levels. All results are presented in tabular form below.

<b>Measured RMS Average Carrier Power Level for the Multicarrier Configurations at Antenna Port 3</b>			
<b>AWS Multicarrier LTE1.4</b>		<b>Multiband Multicarrier LTE1.4</b>	
<b>Bottom Carriers 2010.7 &amp; 2012.1MHz</b>	<b>Top Carrier 2199.3MHz</b>	<b>Bottom Carriers 1930.7 &amp; 1932.1MHz</b>	<b>Top Carrier 2199.3MHz</b>
43.80 dBm (24.0 Watts)	41.10 dBm (12.9 Watts)	See Appendix A for data and test results for this test case	
Total Carrier Power in AWS Band is 36.9 Watts or 45.7 dBm			

All measurement results are provided in the following pages. The total measurement RF path loss of the test setup (attenuator and test cables) was 40.4 dB and is accounted for by the spectrum analyzer reference level offset.

LTE5 Channel Power Plots at Middle Channel and 256QAM Modulation:

Port 1 \_ Middle Channel\_ CCDF

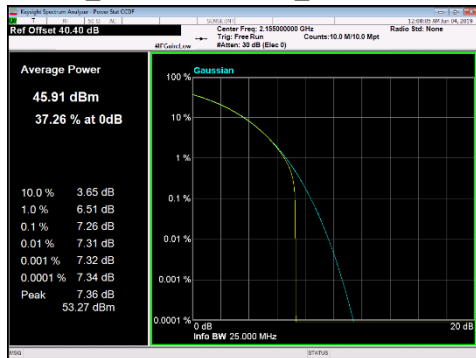

Port 1 \_ Middle Channel\_ Average

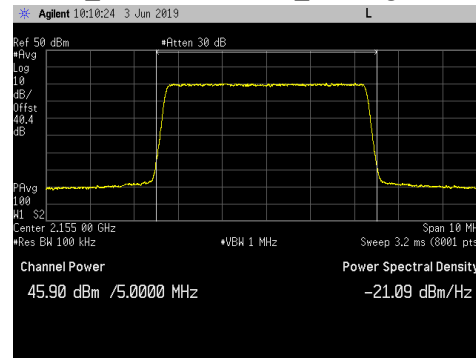

Port 2 \_ Middle Channel\_ CCDF

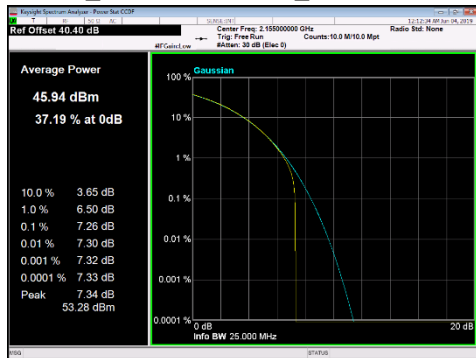

Port 2 \_ Middle Channel\_ Average

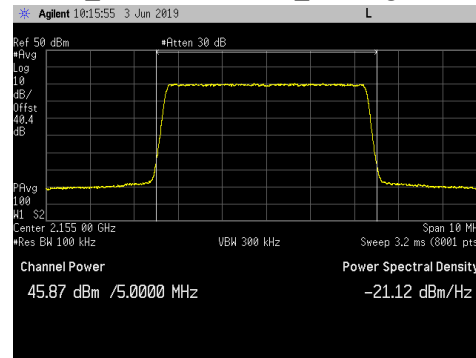

Port 3 \_ Middle Channel\_ CCDF

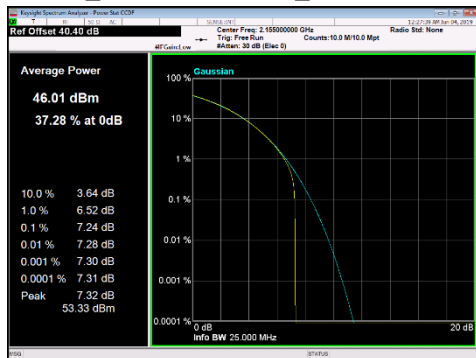

Port 3 \_ Middle Channel\_ Average

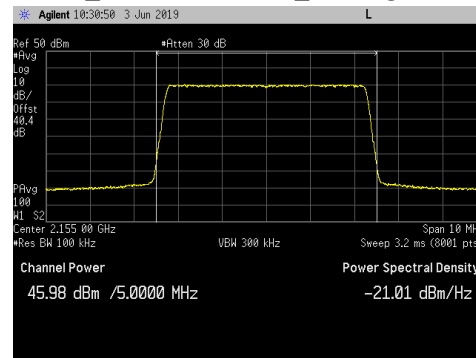

Port 4 \_ Middle Channel\_ CCDF



Port 4 \_ Middle Channel\_ Average

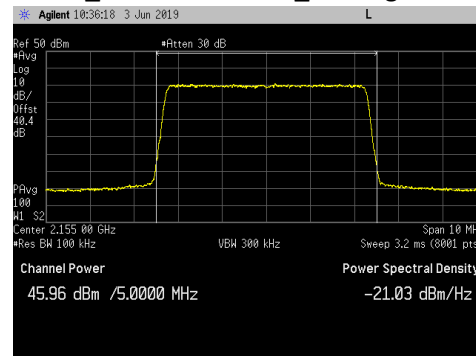

LTE5 Channel Power Plots for Antenna Port 3 at Middle Channel and all Modulation Types:

QPSK\_CCDF

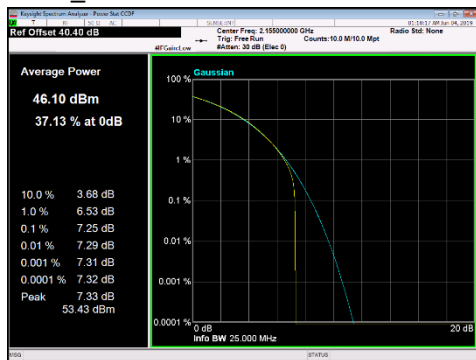

QPSK\_Average

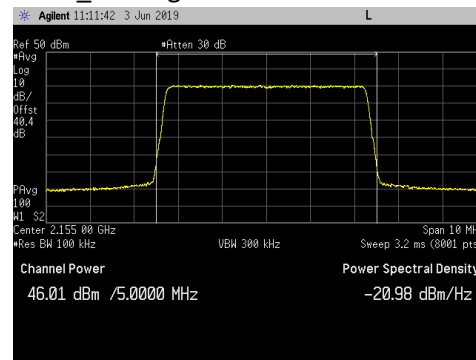

16QAM\_CCDF

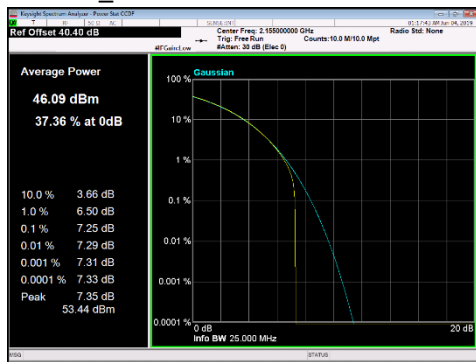

16QAM\_Average

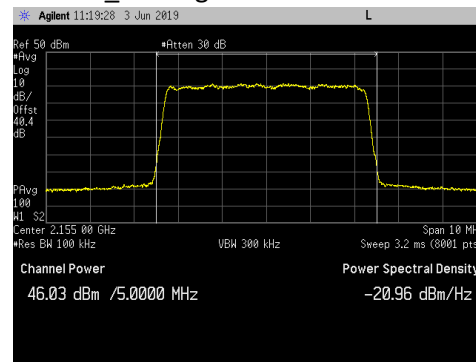

64QAM\_CCDF



64QAM\_Average

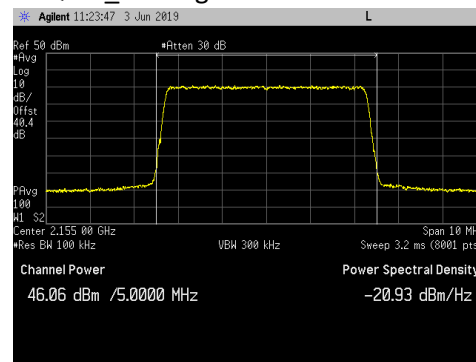

256QAM\_CCDF

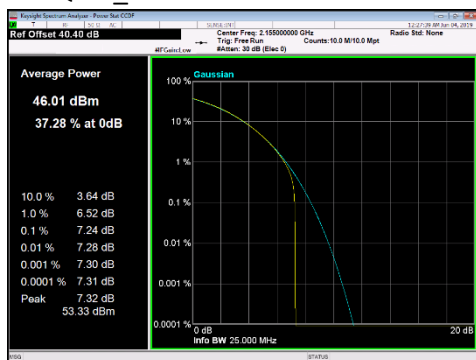

256QAM\_Average

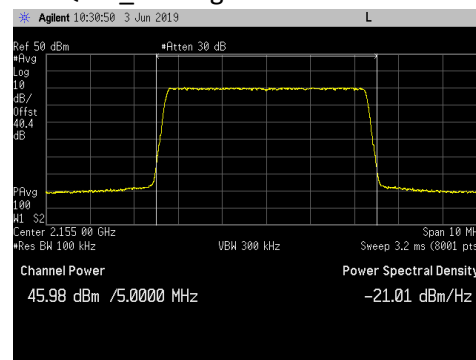

**LTE1.4 Channel Power Plots for Antenna Port 3 and 256QAM Modulation:**

**Bottom Channel\_ CCDF**

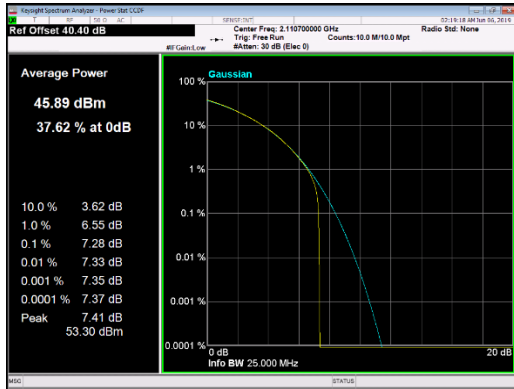

**Bottom Channel\_ Average**

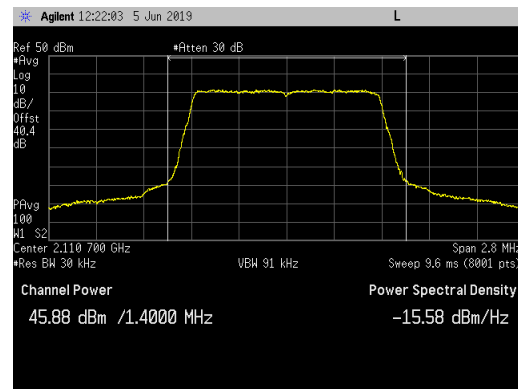

**Middle Channel\_ CCDF**

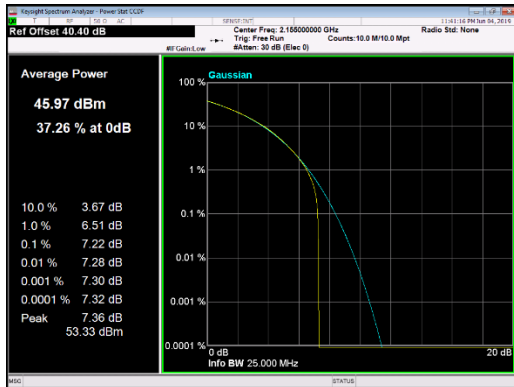

**Middle Channel\_ Average**

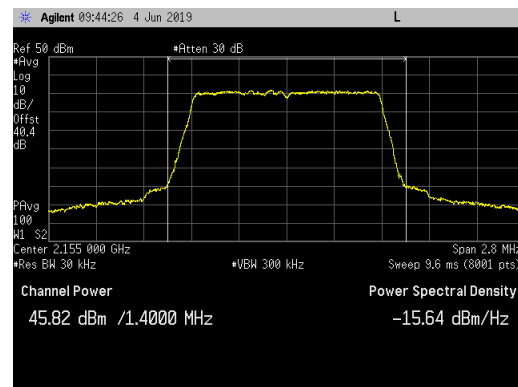

**Top Channel\_ CCDF**

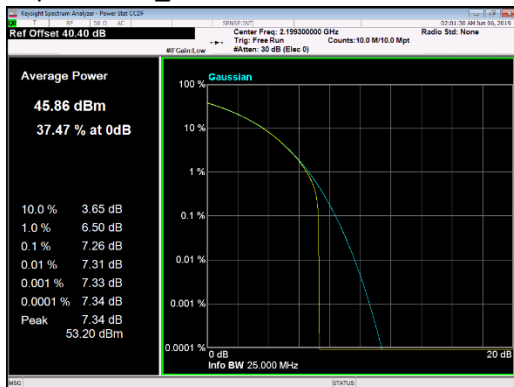

**Top Channel\_ Average**

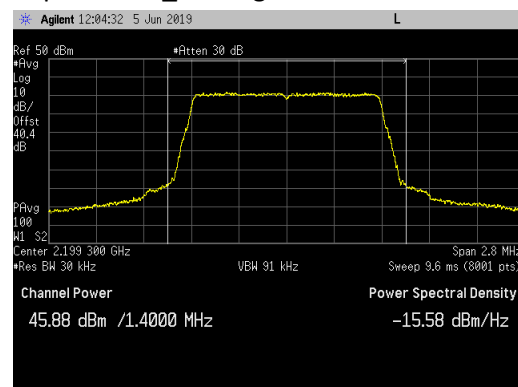

**LTE3 Channel Power Plots for Antenna Port 3 and 256QAM Modulation:**

**Bottom Channel\_ CCDF**

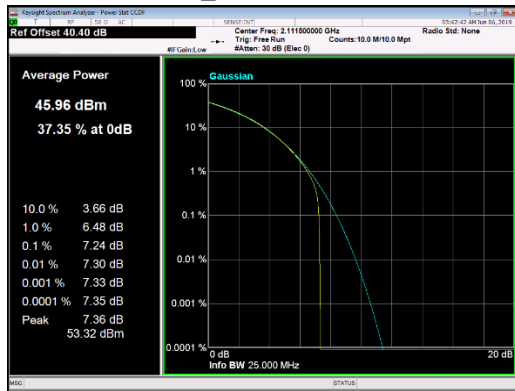

**Bottom Channel\_ Average**

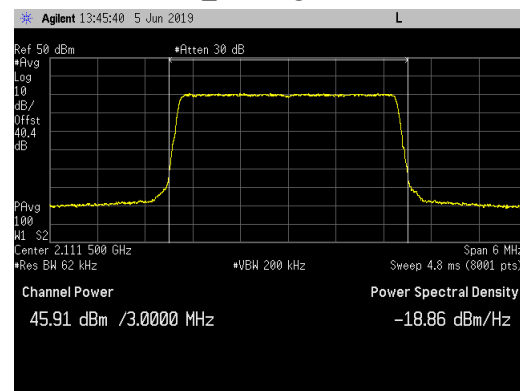

**Middle Channel\_ CCDF**

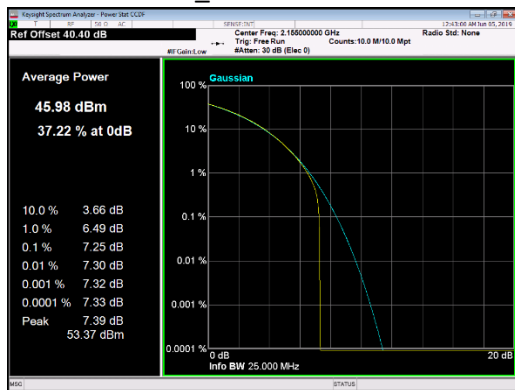

**Middle Channel\_ Average**

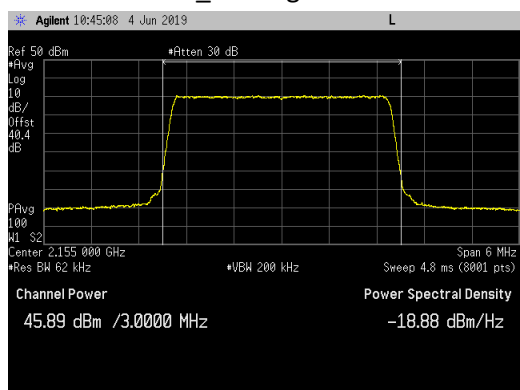

**Top Channel\_ CCDF**

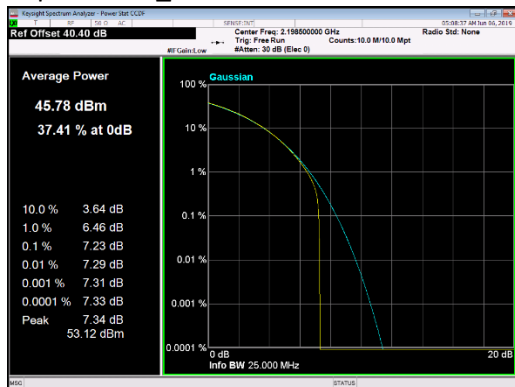

**Top Channel\_ Average**

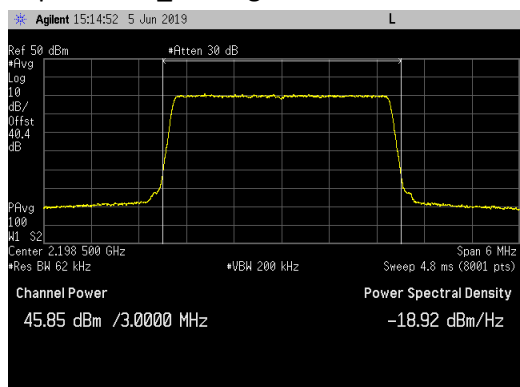



**LTE5 Channel Power Plots for Antenna Port 3 and 256QAM Modulation:**

**Bottom Channel\_ CCDF**

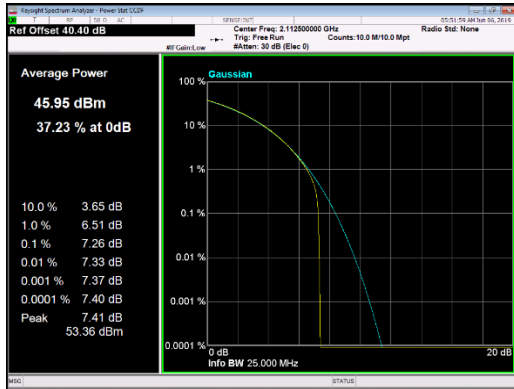

**Bottom Channel\_ Average**

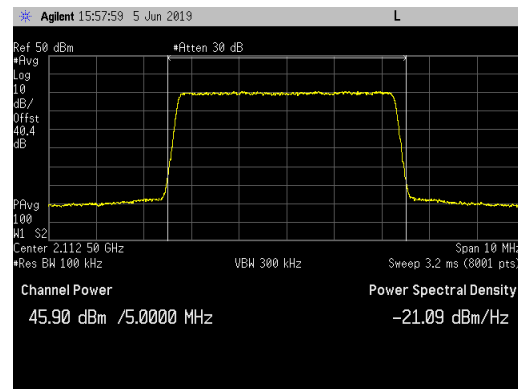

**Middle Channel\_ CCDF**

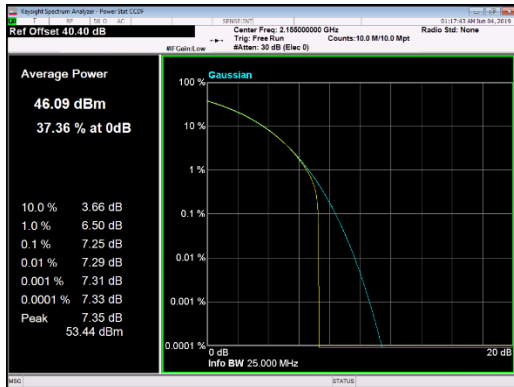

**Middle Channel\_ Average**

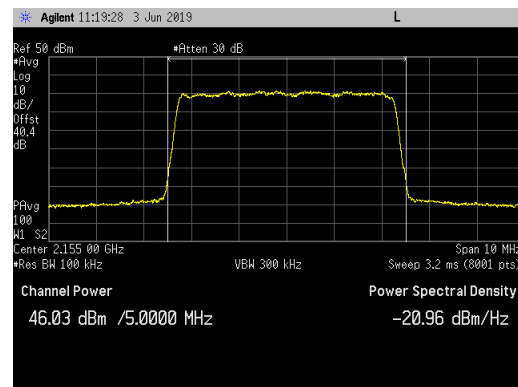

**Top Channel\_ CCDF**

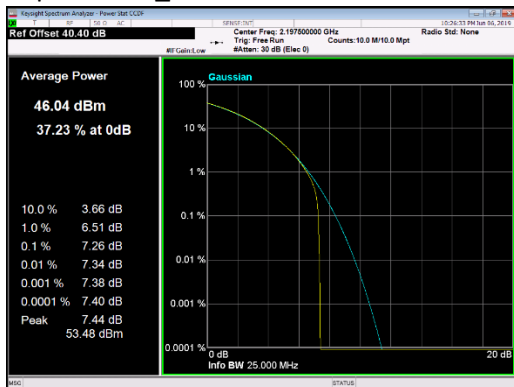

**Top Channel\_ Average**

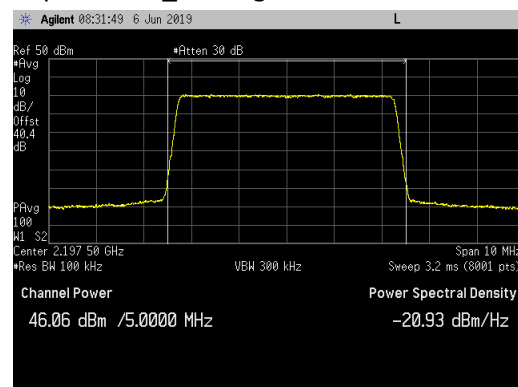

**LTE10 Channel Power Plots for Antenna Port 3 and 256QAM Modulation:**

**Bottom Channel\_ CCDF**

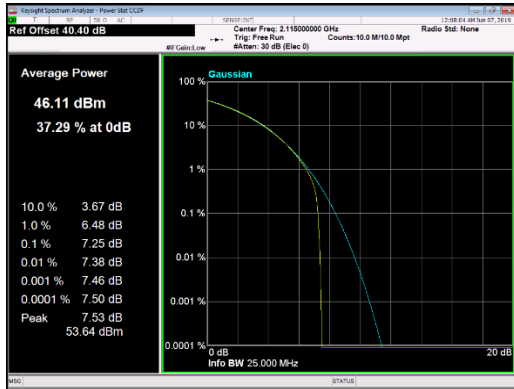

**Bottom Channel\_ Average**

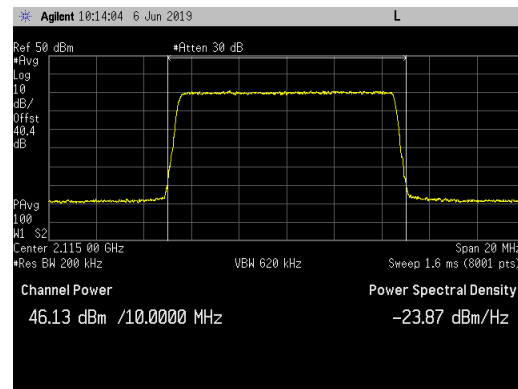

**Middle Channel\_ CCDF**

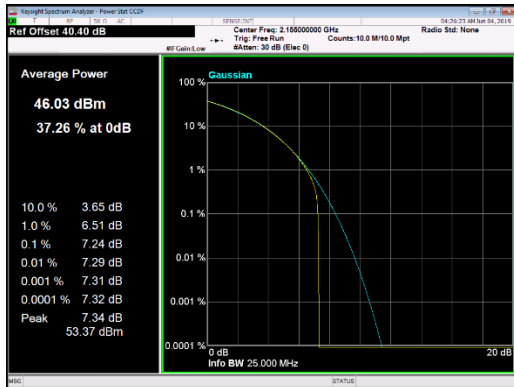

**Middle Channel\_ Average**

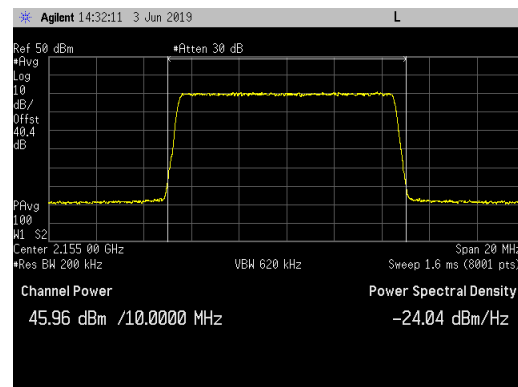

**Top Channel\_ CCDF**

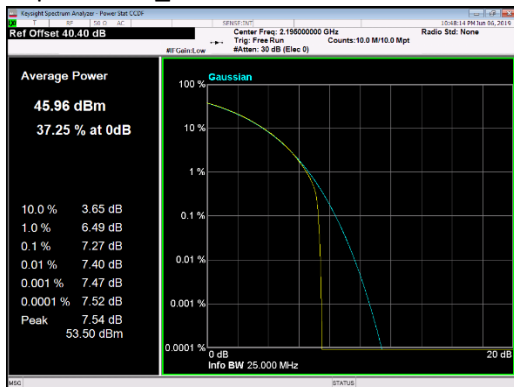

**Top Channel\_ Average**

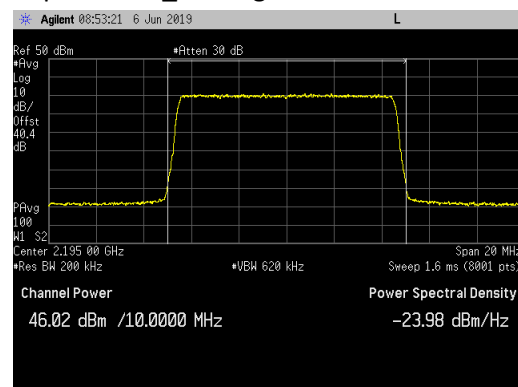

**LTE15 Channel Power Plots for Antenna Port 3 and 256QAM Modulation:**

**Bottom Channel\_ CCDF**

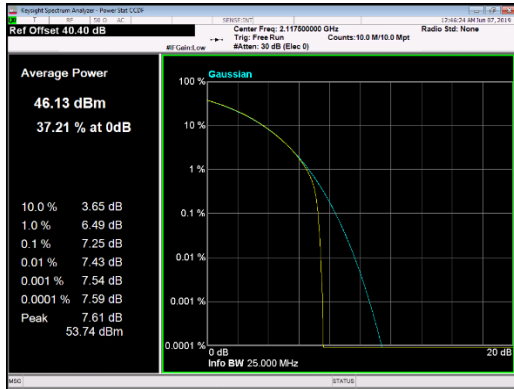

**Bottom Channel\_ Average**

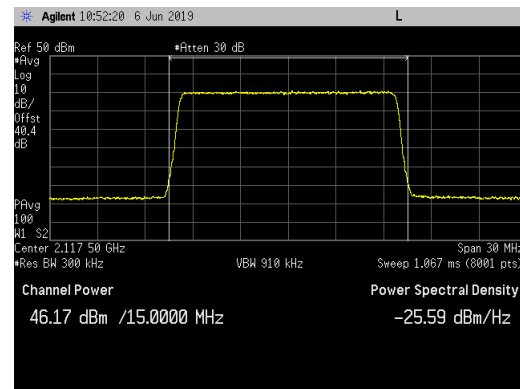

**Middle Channel\_ CCDF**

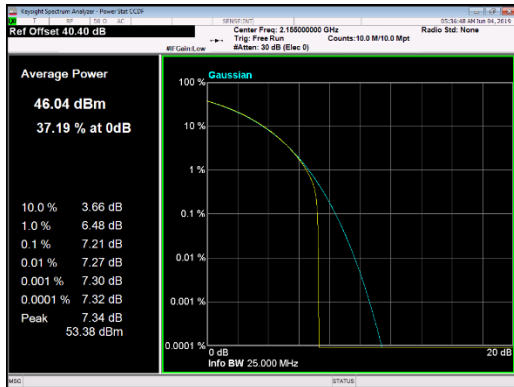

**Middle Channel\_ Average**

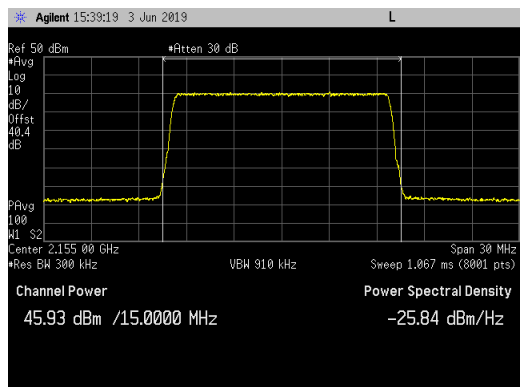

**Top Channel\_ CCDF**

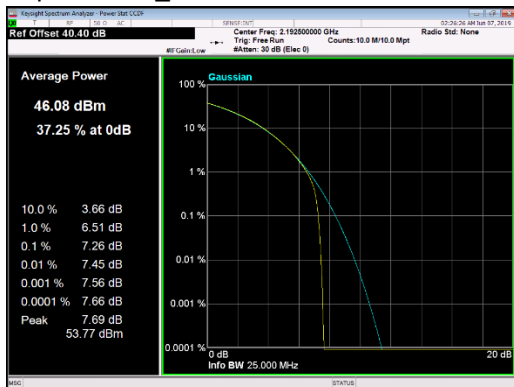

**Top Channel\_ Average**

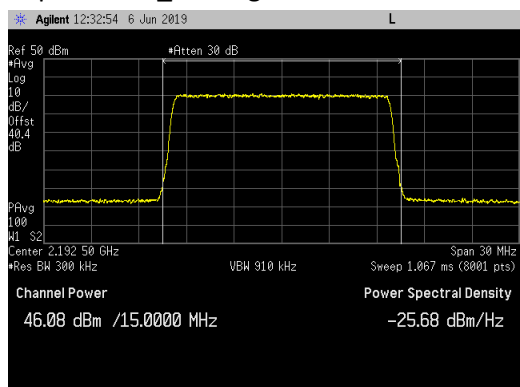

LTE20 Channel Power Plots for Antenna Port 3 and 256QAM Modulation:

Bottom Channel\_ CCDF

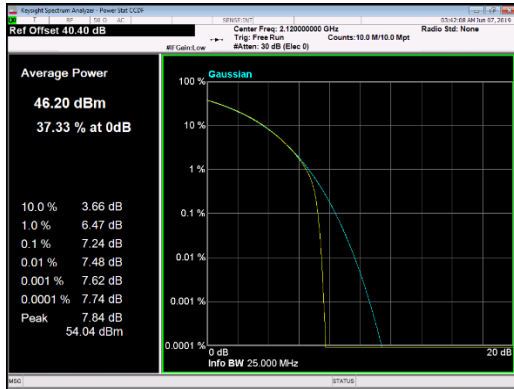

Bottom Channel\_ Average

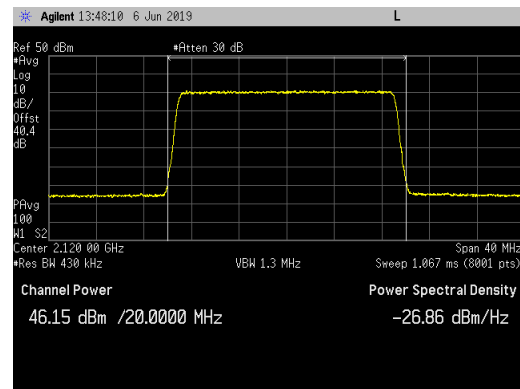

Middle Channel\_ CCDF

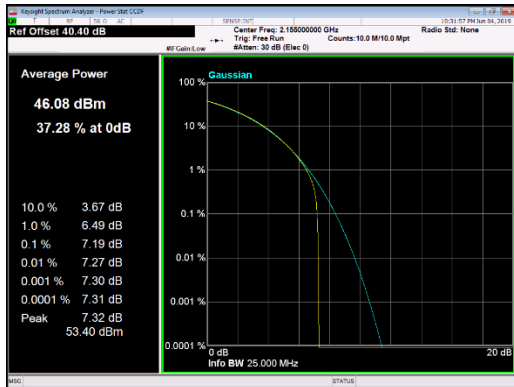

Middle Channel\_ Average

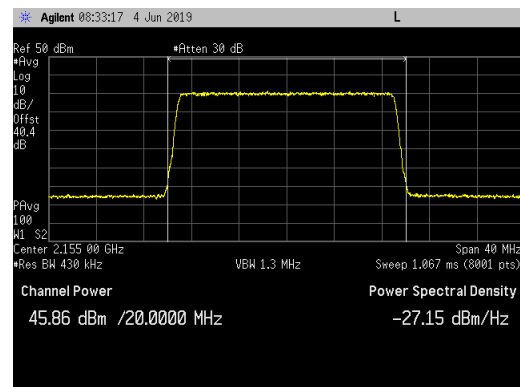

Top Channel\_ CCDF

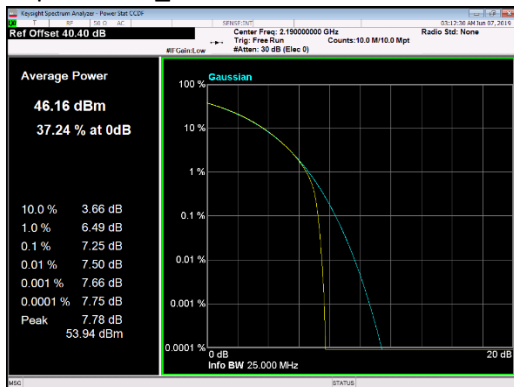

Top Channel\_ Average

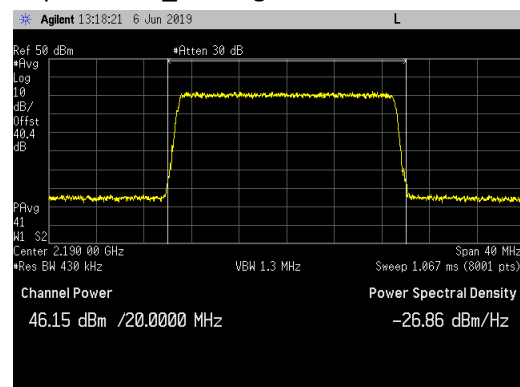

**Multicarrier LTE1.4 (Carriers at 2110.7, 2112.1 & 2199.3MHz) Channel Power Plots for Antenna Port 3:**

256QAM\_ 2110.7 & 2112.1MHz\_ Average Power

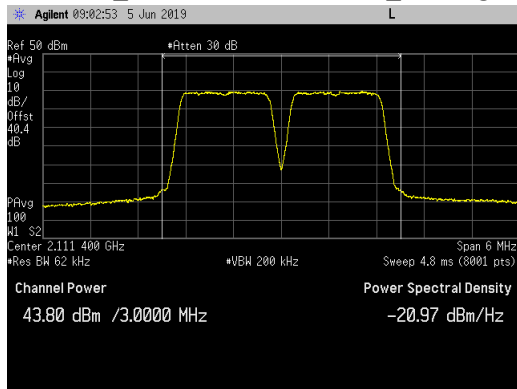

256QAM\_ 2199.3MHz\_ Average Power

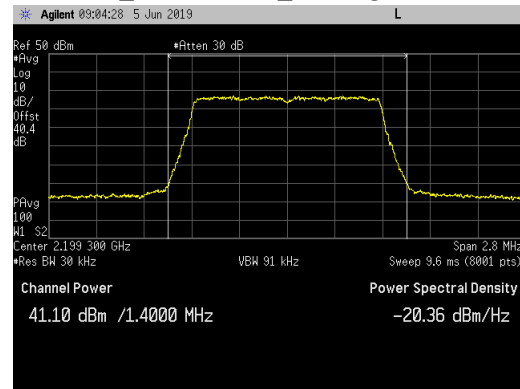

**Emission Bandwidth (26 dB down and 99%)**

Emission bandwidth measurements were made at antenna port 3 on the middle channel with maximum RF output power. All available LTE modulations (QPSK, 16QAM, 64QAM and 256QAM) were used. All available LTE channel bandwidths (1.4 MHz, 3MHz, 5MHz, 10MHz, 15MHz, and 20MHz) were used.

The 26dB emission bandwidth was measured in accordance with section 4 of FCC KDB 971168 D01v03r01 and ANSI C63.26 section 5.4. The 99% occupied bandwidth was measured in accordance with section 6.7 of RSS-Gen Issue 5. For both measurements, an occupied bandwidth built-in function in the spectrum analyzer was used. The results are provided in the following table. The largest emission bandwidths in each channel type are highlighted.

LTE Channel Bandwidth	Modulation Type							
	QPSK		16QAM		64QAM		256QAM	
	26dB (MHz)	99% (MHz)	26dB (MHz)	99% (MHz)	26dB (MHz)	99% (MHz)	26dB (MHz)	99% (MHz)
1.4M	1.240	1.1114	1.235	1.1083	<b>1.247</b>	<b>1.1160</b>	<b>1.247</b>	1.1150
3M	2.922	2.7071	2.926	2.7054	2.923	2.7059	<b>2.927</b>	<b>2.7197</b>
5M	<b>4.842</b>	4.4942	4.834	4.4821	4.834	<b>4.4982</b>	4.833	4.4959
10M	9.649	8.9693	9.626	<b>8.9854</b>	<b>9.670</b>	8.9785	9.631	8.9808
15M	14.443	13.4502	14.419	13.5017	14.466	<b>13.4621</b>	<b>14.474</b>	13.4587
20M	<b>19.390</b>	17.9554	19.243	<b>17.9712</b>	19.368	17.9463	19.334	17.9695

Emission bandwidth measurement data are provided in the following pages.

LTE1.4 and LTE3 Emission Bandwidth Plots on the Middle Channel for Antenna Port 3:

LTE1.4\_QPSK

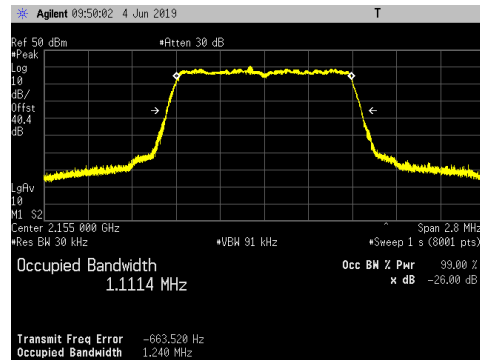

LTE3\_QPSK

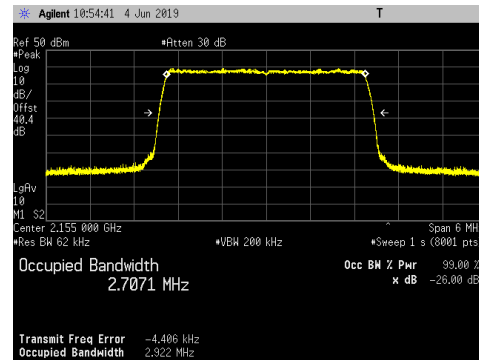

LTE1.4\_16QAM

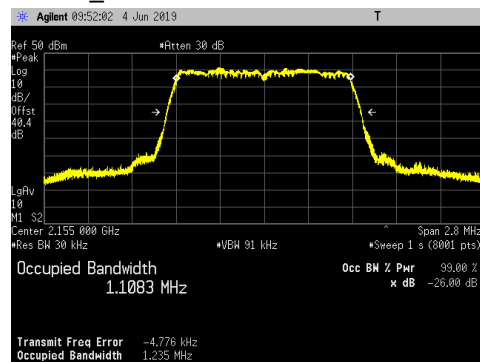

LTE3\_16QAM

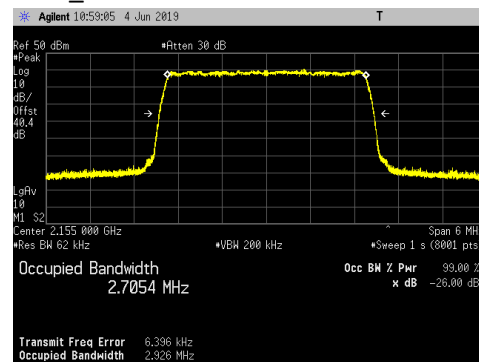

LTE1.4\_64QAM

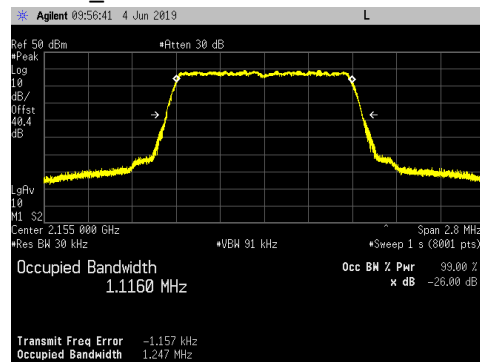

LTE3\_64QAM

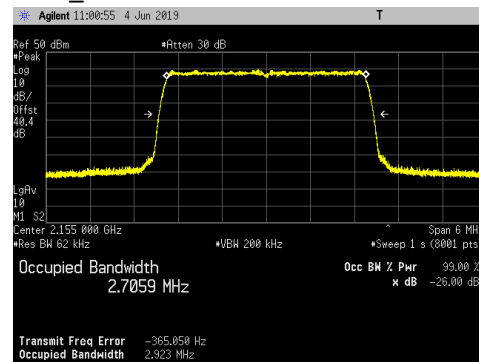

LTE1.4\_256QAM

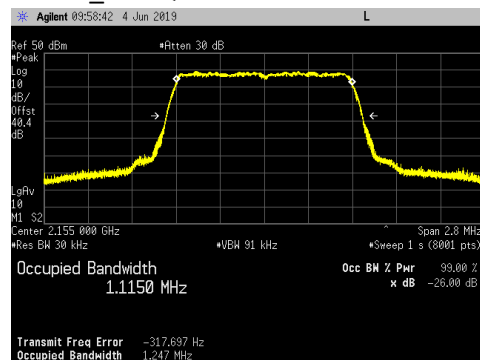

LTE3\_256QAM

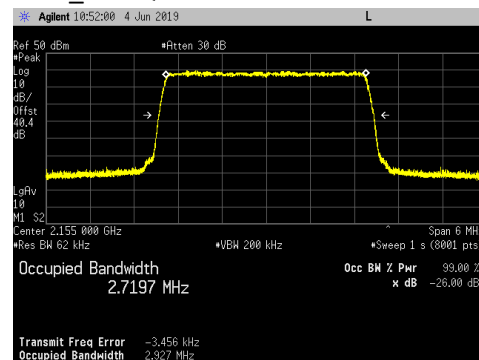

LTE5 and LTE10 Emission Bandwidth Plots on the Middle Channel for Antenna Port 3:

LTE5\_QPSK

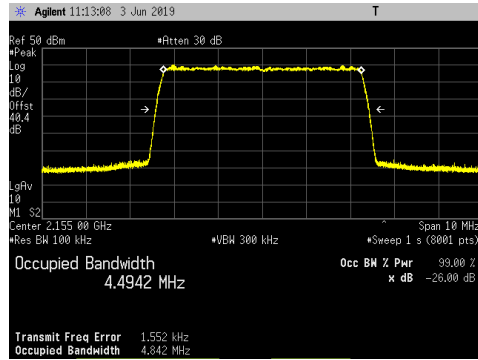

LTE10\_QPSK

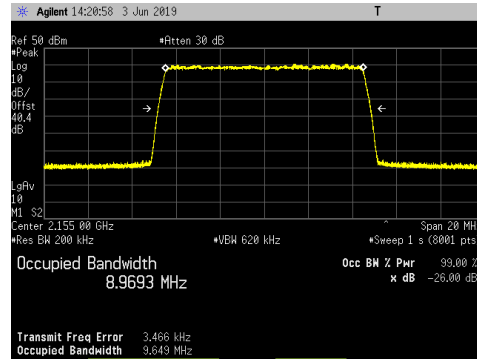

LTE5\_16QAM

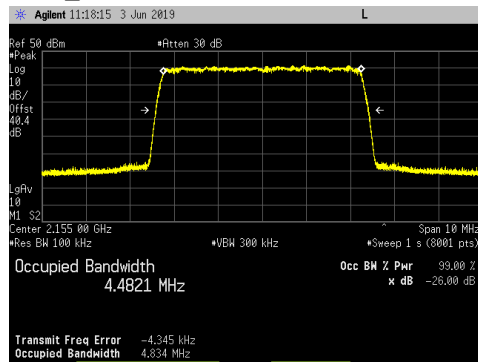

LTE10\_16QAM

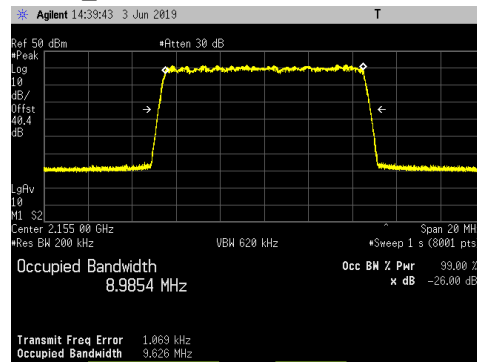

LTE5\_64QAM

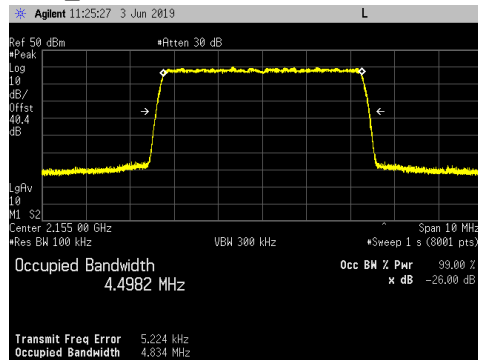

LTE10\_64QAM

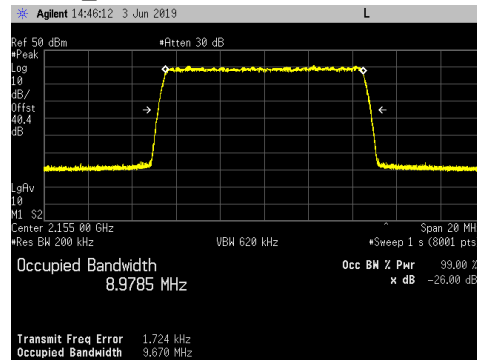

LTE5\_256QAM

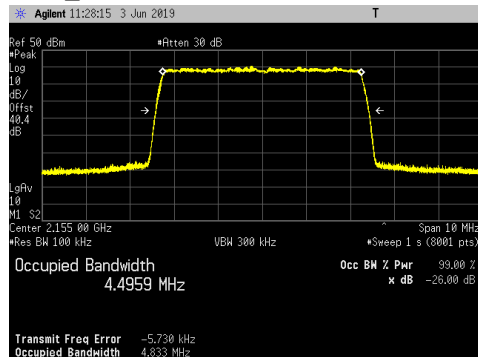

LTE10\_256QAM

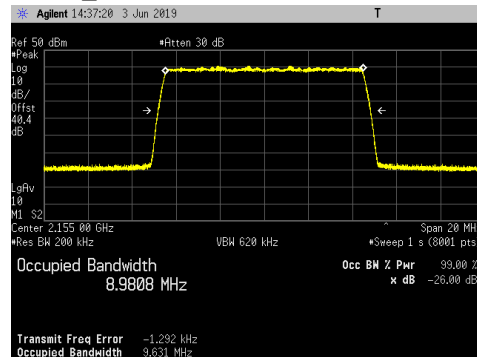



LTE15 and LTE20 Emission Bandwidth Plots on the Middle Channel for Antenna Port 3:

LTE15\_QPSK

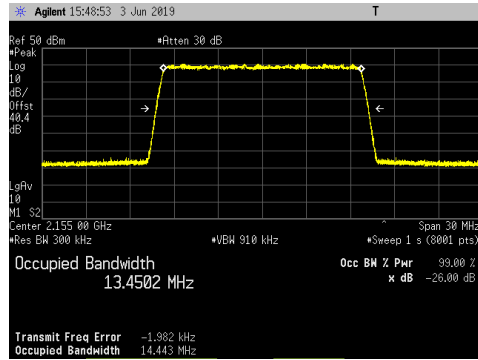

LTE20\_QPSK

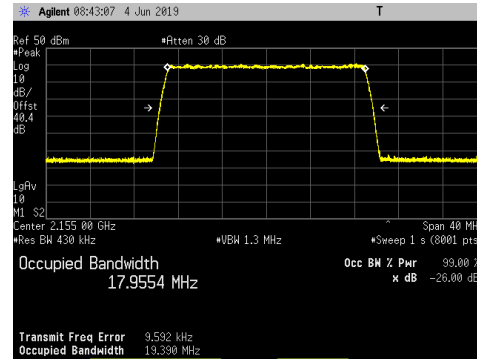

LTE15\_16QAM

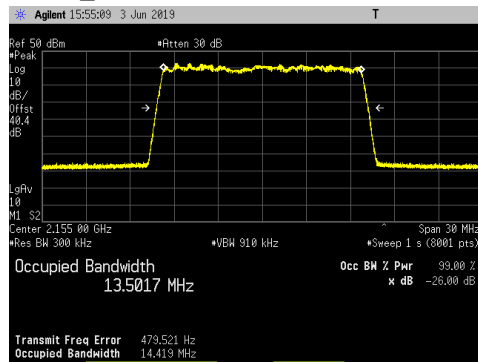

LTE20\_16QAM

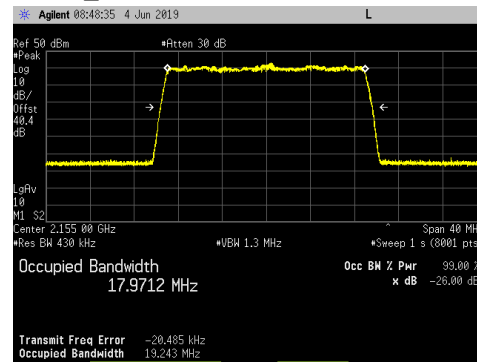

LTE15\_64QAM

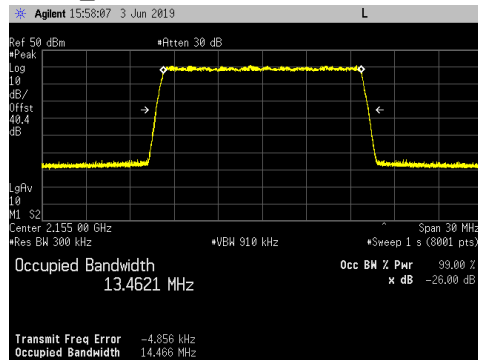

LTE20\_64QAM

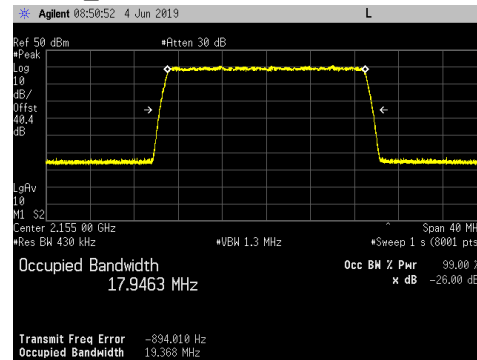

LTE15\_256QAM

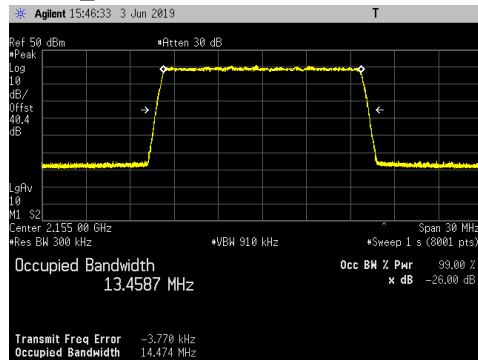

LTE20\_256QAM

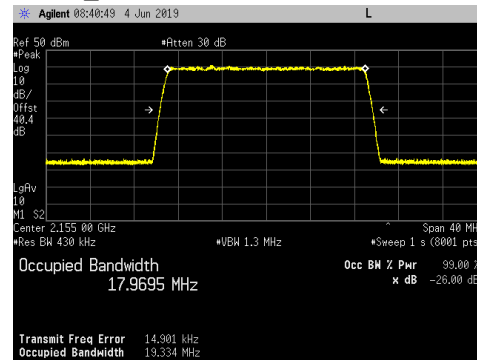

## **Antenna Port Conducted Band Edge**

Conducted band edge measurements were made at RRH antenna port 3.

### ***Single Carrier Test Cases***

The RRH was operated at the band edge frequencies with all modulation types (QPSK, 16QAM, 64QAM and 256QAM) for all LTE bandwidths (1.4MHz, 3MHz, 5MHz, 10MHz, 15MHz and 20MHz) at maximum power (40 watts/port and 40 watts/carrier).

### ***AWS Multicarrier Multiband Test Case***

In the AWS band: Three LTE1.4 carriers (based upon KDB 971168 D03v01) using two carriers (with minimum spacing between carrier frequencies) at the lower band edge (EARFCN 66443: 2110.7 & EARFCN 66457: 2112.1MHz) and a third carrier with maximum spacing between the other two carrier frequencies (EARFCN 67329: 2199.3MHz) at the upper band edge. In the PCS band: Single LTE1.4 carrier at the middle channel (EARFCN 8365: 1962.5MHz). The smallest channel bandwidth was selected to maximize carrier power spectral density. The carriers were operated at maximum power (~13W/AWS carrier and 80W/PCS carrier) with at total port power of 120 watts (80W for PCS band carrier + 40W for AWS band carriers). The same modulation type was used for both PCS and AWS carriers.

### ***Multicarrier Multiband Test Case***

Three LTE1.4 carriers (based upon KDB 971168 D03v01) using two carriers (with minimum spacing between carrier frequencies) at the PCS band lower band edge (EARFCN 8047: 1930.7 & EARFCN 8061: 1932.1MHz) and a third carrier with maximum spacing between the other two carrier frequencies (EARFCN 67329: 2199.3MHz) at the AWS band upper band edge. The smallest channel bandwidth was selected to maximize carrier power spectral density. The carriers were operated at maximum power (40W/PCS carrier and 40W/AWS carrier) with at total port power of 120 watts (80W for PCS band carriers + 40W for AWS band carrier). The same modulation type was used for both PCS and AWS carriers. Data for this test case is in Appendix A.

The limit of -19dBm was used in the certification testing. The limit is adjusted to -19dBm [-13dBm -10 log (4)] per FCC KDB 662911D01 v02r01 because the BTS may operate as a 4 port MIMO transmitter.

Measurements were performed with the spectrum analyzer in the RMS average mode over 100 traces. In the 1MHz bands outside and adjacent to the frequency block, a resolution bandwidth of 1% of the emission bandwidth was used. In the 1 to 2MHz frequency range outside the band edge (i.e.: 2108 to 2109MHz and 2201 to 2202MHz bands) the RBW was again reduced to 1% of the emission bandwidth and the power integrated over 1MHz. In the 2 to 22MHz frequency range outside the band edge (i.e.: 2088 to 2108MHz and 2202 to 2222MHz bands) a 1MHz RBW and 3MHz VBW was used.



The results are summarized in the following table. The highest (worst case) emissions from the measurement data are provided.

Ch BW, Carrier Freq, Carrier Pwr		QPSK (dBm)		16QAM (dBm)		64QAM (dBm)		256QAM (dBm)	
AWS Band	PCS Band	LBE	UBE	LBE	UBE	LBE	UBE	LBE	UBE
LTE1.4, BC, 40W	Carrier Off	-21.635	N/A	-22.048	N/A	-21.861	N/A	-21.913	N/A
LTE3, BC, 40W	Carrier Off	-20.805	N/A	-21.018	N/A	-20.602	N/A	-20.702	N/A
LTE5, BC, 40W	Carrier Off	-21.441	N/A	-21.274	N/A	-22.227	N/A	-21.667	N/A
LTE10, BC, 40W	Carrier Off	-24.858	N/A	-24.751	N/A	-24.890	N/A	-23.858	N/A
LTE15, BC, 40W	Carrier Off	-24.385	N/A	-24.262	N/A	-23.744	N/A	-25.407	N/A
LTE20, BC, 40W	Carrier Off	-25.573	N/A	-25.835	N/A	-25.756	N/A	-25.857	N/A
LTE1.4, TC, 40W	Carrier Off	N/A	-21.005	N/A	-22.393	N/A	-22.190	N/A	-21.749
LTE3, TC, 40W	Carrier Off	N/A	-21.139	N/A	-20.367	N/A	-20.241	N/A	-20.219
LTE5, TC, 40W	Carrier Off	N/A	-22.287	N/A	-22.340	N/A	-22.182	N/A	-22.421
LTE10, TC, 40W	Carrier Off	N/A	-23.445	N/A	-23.605	N/A	-23.532	N/A	-24.170
LTE15, TC, 40W	Carrier Off	N/A	-23.490	N/A	-23.752	N/A	-23.548	N/A	-23.703
LTE20, TC, 40W	Carrier Off	N/A	-24.776	N/A	-26.47	N/A	-24.757	N/A	-24.704
AWS Multicarrier LTE1.4, BC, BC+1 & TC, 13W + 13W + 13W	LTE1.4, MC, 80W	-22.018	-19.74	-22.499	-19.63	-22.732	-19.89	-22.718	-19.60
LTE1.4, TC, 40W	PCS Multicarrier LTE1.4, BC & BC+1, 40W + 40W	See Appendix A for data and test results for this test case.							

The total measurement RF path loss of the test setup (attenuator and test cables) was 40.4 dB and is accounted for by the spectrum analyzer reference level offset. The display line on the plots reflects the required limit.

Conducted band edge measurements are provided in the following pages.

Single Carrier LTE1.4 Band Edge Plots for Antenna Port 3 and QPSK Modulation:

Bottom Channel\_ LBE\_ 2109 to 2131MHz

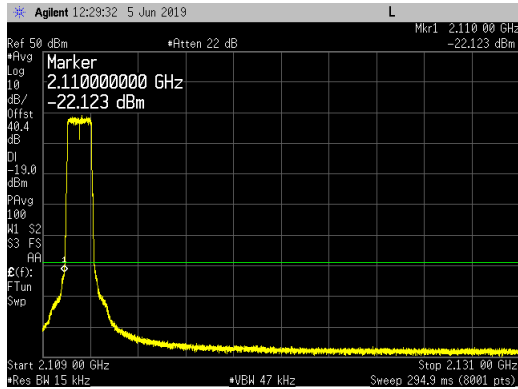

Top Channel\_ UBE\_ 2179 to 2201MHz

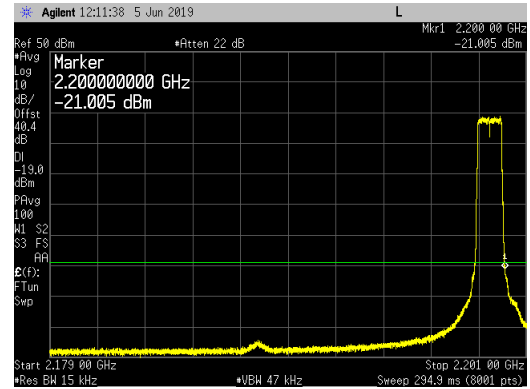

Bottom Channel\_ LBE\_ 2108 to 2109MHz

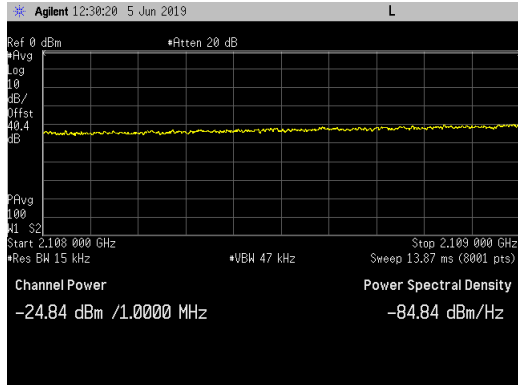

Top Channel\_ UBE\_ 2201 to 2202MHz

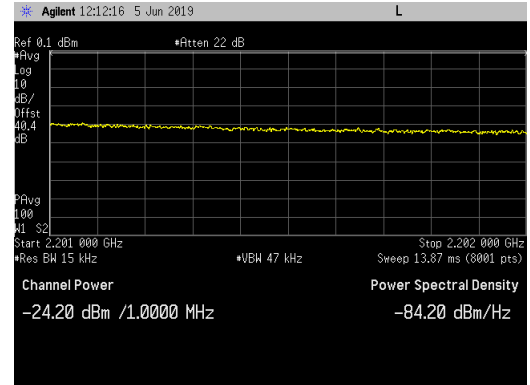

Bottom Channel\_ LBE\_ 2088 to 2108MHz

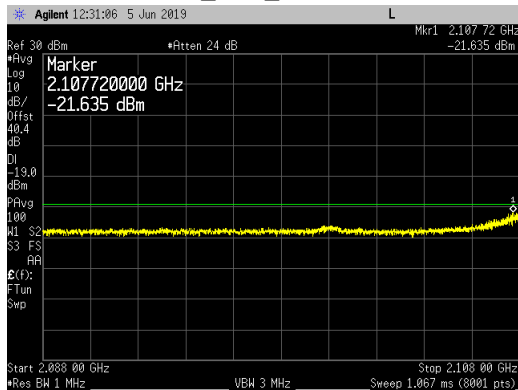

Top Channel\_ UBE\_ 2202 to 2222MHz

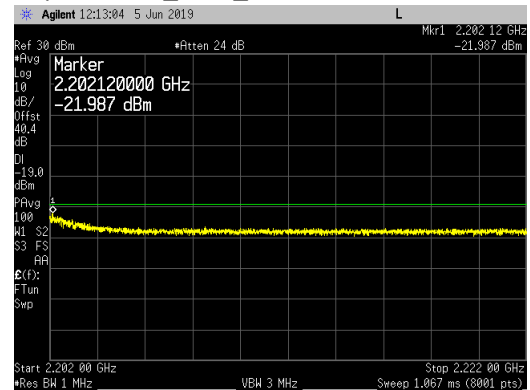

Single Carrier LTE1.4 Band Edge Plots for Antenna Port 3 and 16QAM Modulation:

Bottom Channel\_ LBE\_ 2109 to 2131MHz

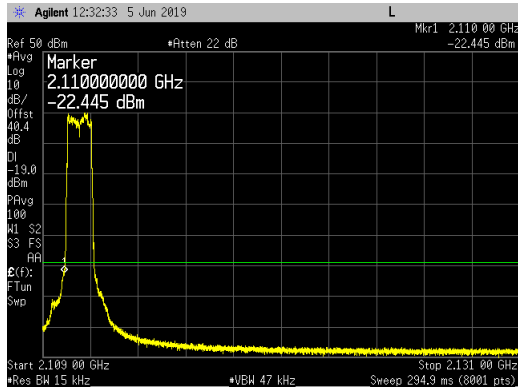

Top Channel\_ UBE\_ 2179 to 2201MHz

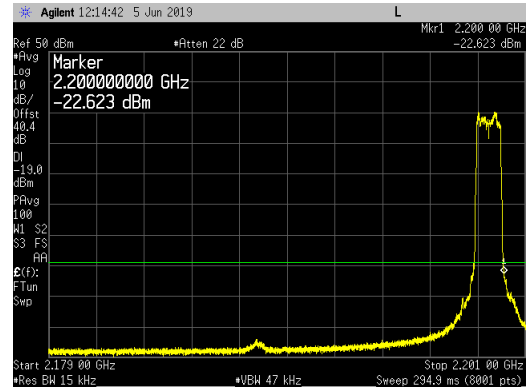

Bottom Channel\_ LBE\_ 2108 to 2109MHz

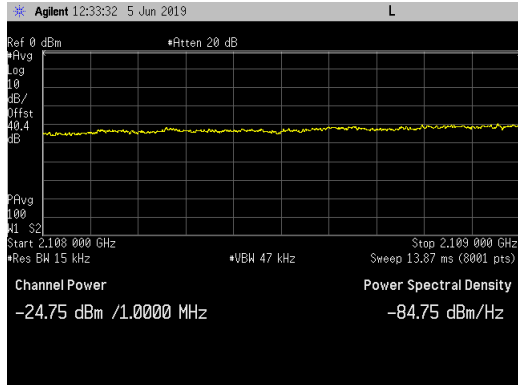

Top Channel\_ UBE\_ 2201 to 2202MHz

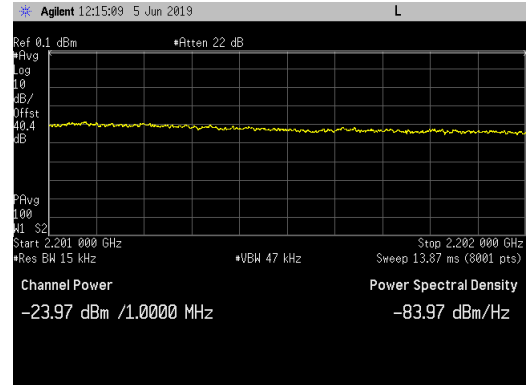

Bottom Channel\_ LBE\_ 2088 to 2108MHz

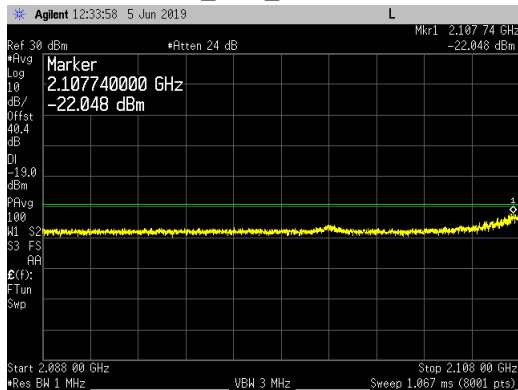

Top Channel\_ UBE\_ 2202 to 2222MHz

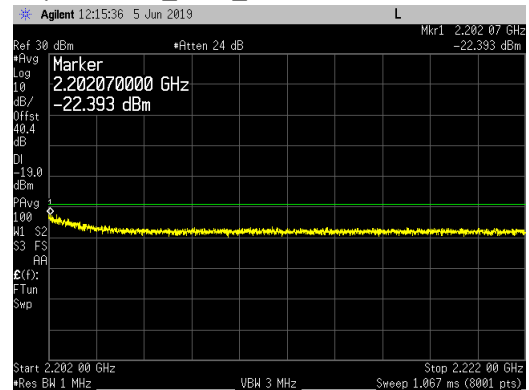

Single Carrier LTE1.4 Band Edge Plots for Antenna Port 3 and 64QAM Modulation:

Bottom Channel\_ LBE\_ 2109 to 2131MHz

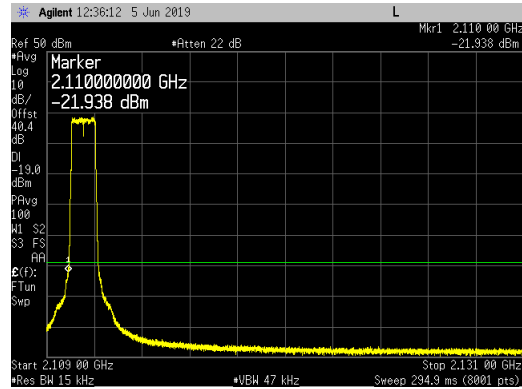

Top Channel\_ UBE\_ 2179 to 2201MHz

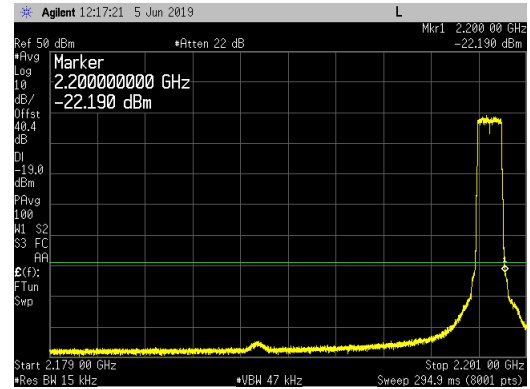

Bottom Channel\_ LBE\_ 2108 to 2109MHz

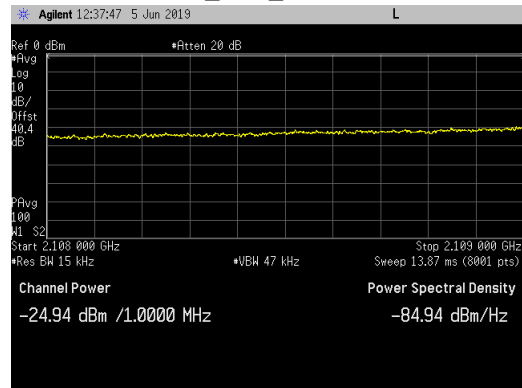

Top Channel\_ UBE\_ 2201 to 2202MHz

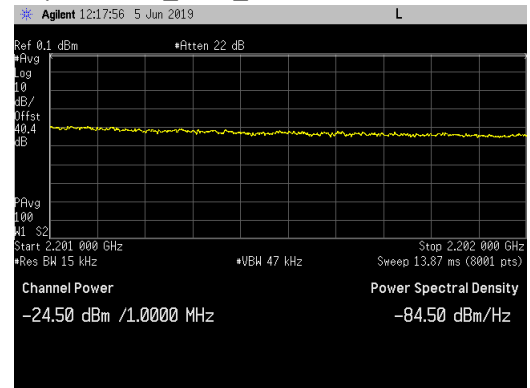

Bottom Channel\_ LBE\_ 2088 to 2108MHz

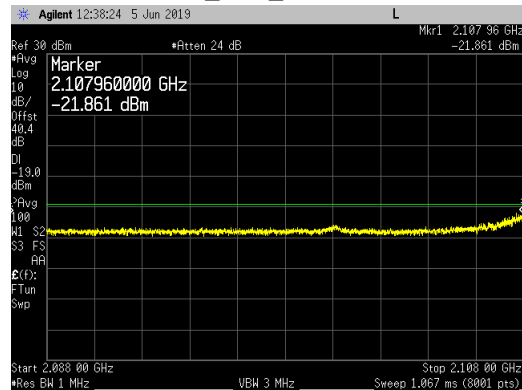

Top Channel\_ UBE\_ 2202 to 2222MHz

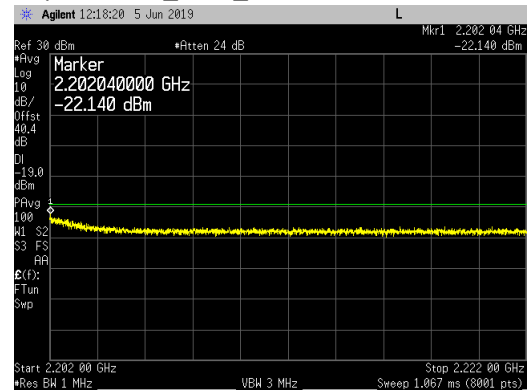

Single Carrier LTE1.4 Band Edge Plots for Antenna Port 3 and 256QAM Modulation:

Bottom Channel\_ LBE\_ 2109 to 2131MHz

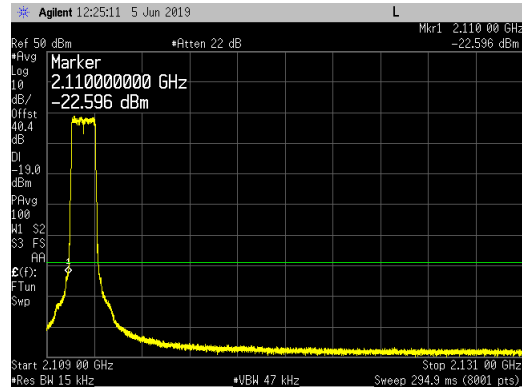

Top Channel\_ UBE\_ 2179 to 2201MHz

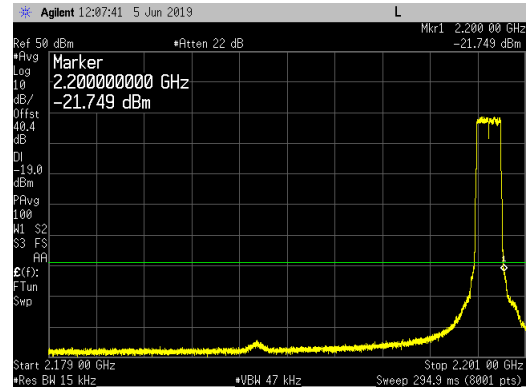

Bottom Channel\_ LBE\_ 2108 to 2109MHz

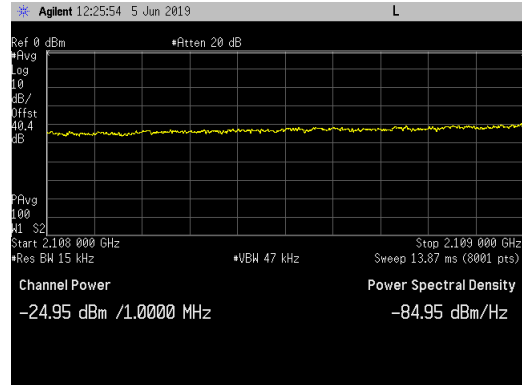

Top Channel\_ UBE\_ 2201 to 2202MHz

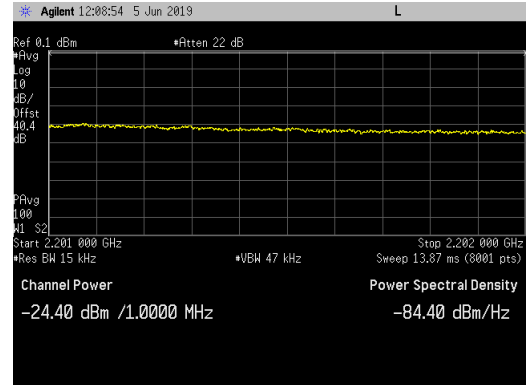

Bottom Channel\_ LBE\_ 2088 to 2108MHz

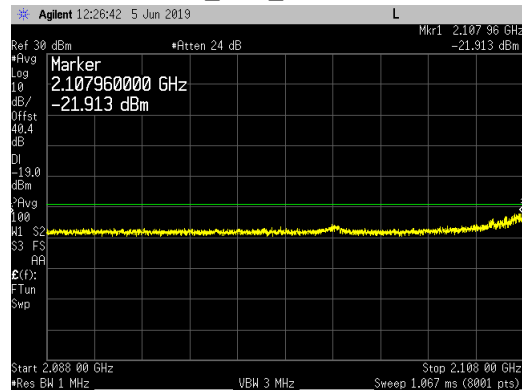

Top Channel\_ UBE\_ 2202 to 2222MHz

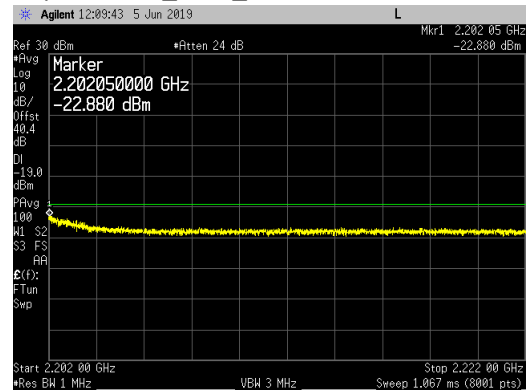

Single Carrier LTE3 Band Edge Plots for Antenna Port 3 and QPSK Modulation:

Bottom Channel\_ LBE\_ 2109 to 2131MHz

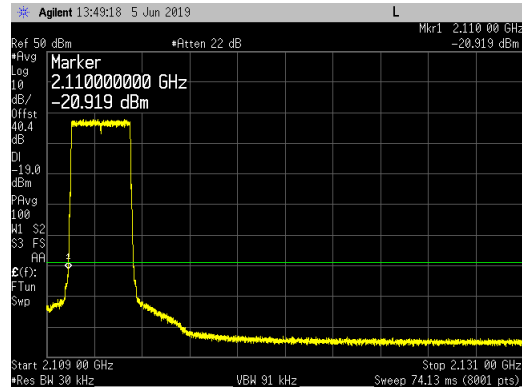

Top Channel\_ UBE\_ 2179 to 2201MHz

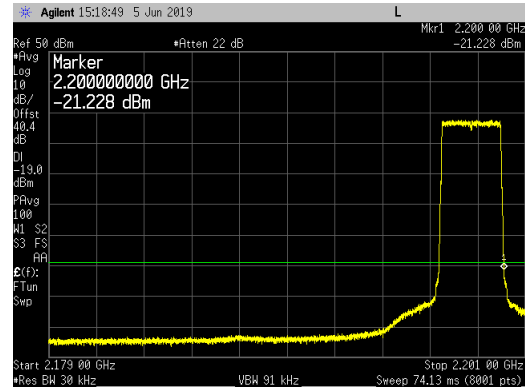

Bottom Channel\_ LBE\_ 2108 to 2109MHz

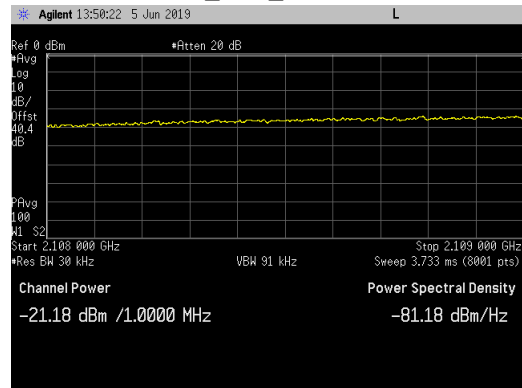

Top Channel\_ UBE\_ 2201 to 2202MHz

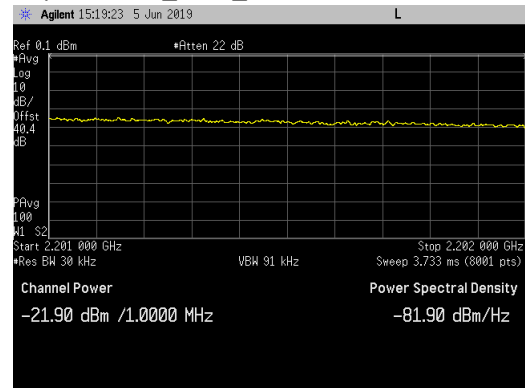

Bottom Channel\_ LBE\_ 2088 to 2108MHz

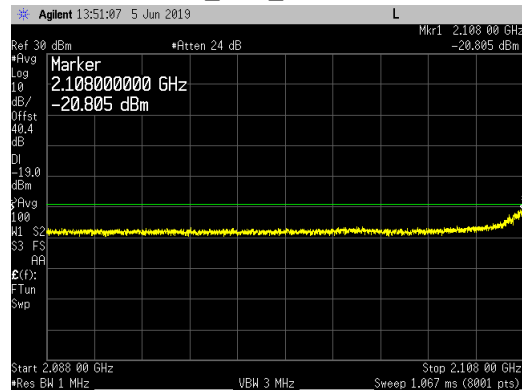

Top Channel\_ UBE\_ 2202 to 2222MHz

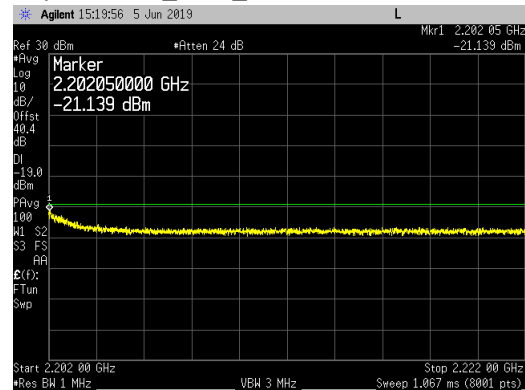



Single Carrier LTE3 Band Edge Plots for Antenna Port 3 and 16QAM Modulation:

Bottom Channel\_ LBE\_ 2109 to 2131MHz

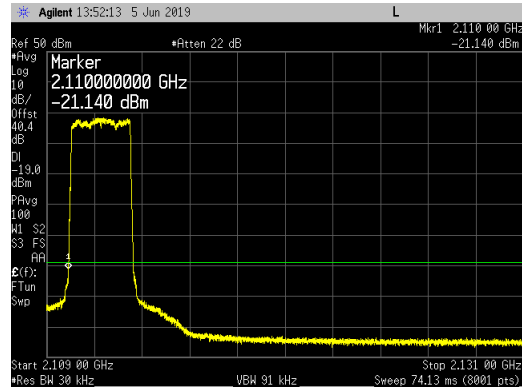

Top Channel\_ UBE\_ 2179 to 2201MHz

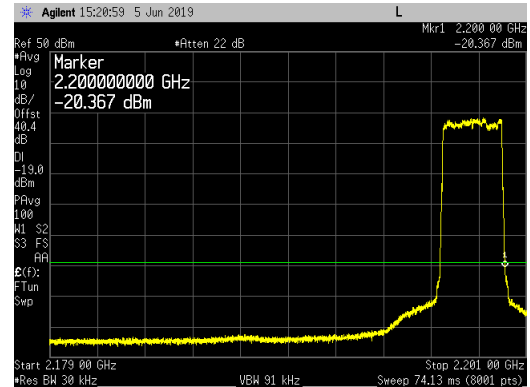

Bottom Channel\_ LBE\_ 2108 to 2109MHz

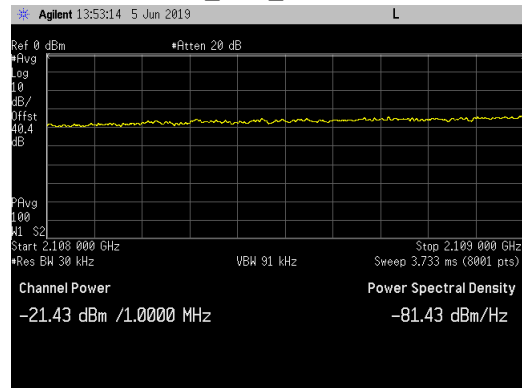

Top Channel\_ UBE\_ 2201 to 2202MHz

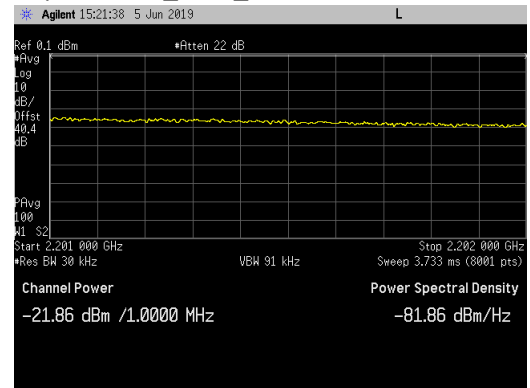

Bottom Channel\_ LBE\_ 2088 to 2108MHz

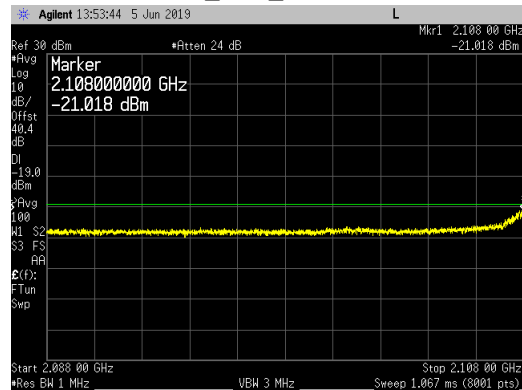

Top Channel\_ UBE\_ 2202 to 2222MHz

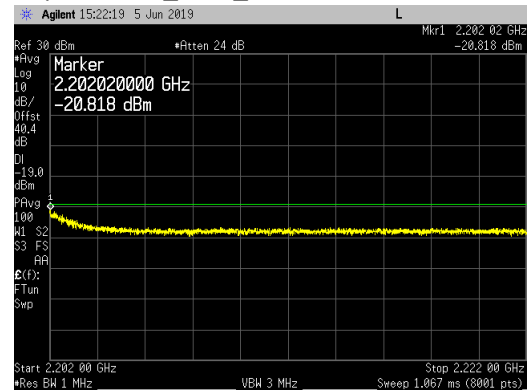

Single Carrier LTE3 Band Edge Plots for Antenna Port 3 and 64QAM Modulation:

Bottom Channel\_ LBE\_ 2109 to 2131MHz

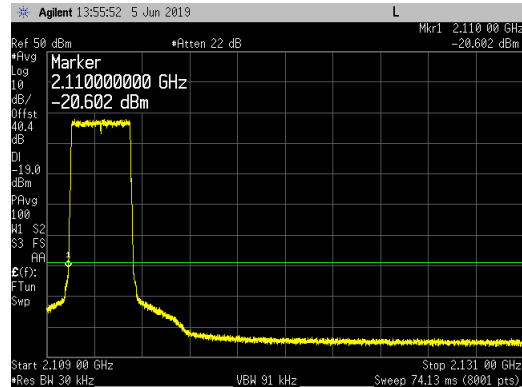

Top Channel\_ UBE\_ 2179 to 2201MHz

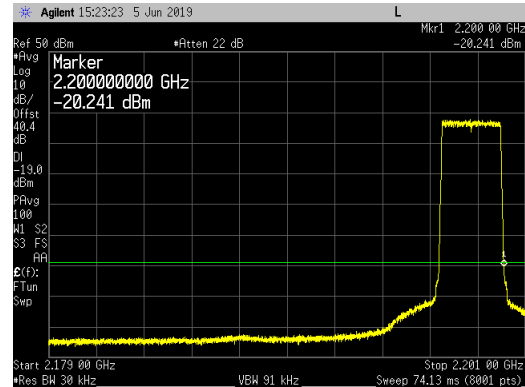

Bottom Channel\_ LBE\_ 2108 to 2109MHz

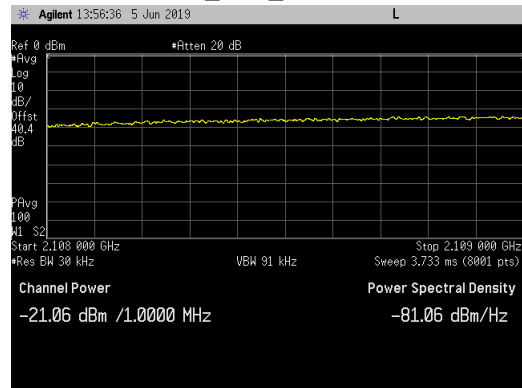

Top Channel\_ UBE\_ 2201 to 2202MHz

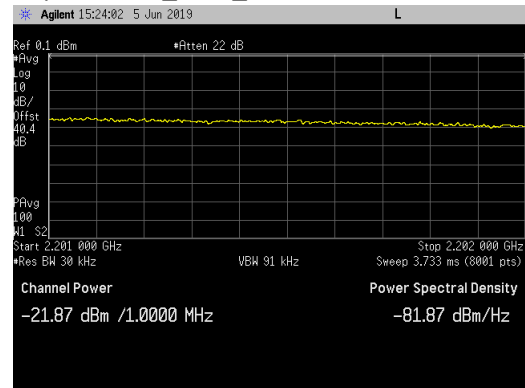

Bottom Channel\_ LBE\_ 2088 to 2108MHz

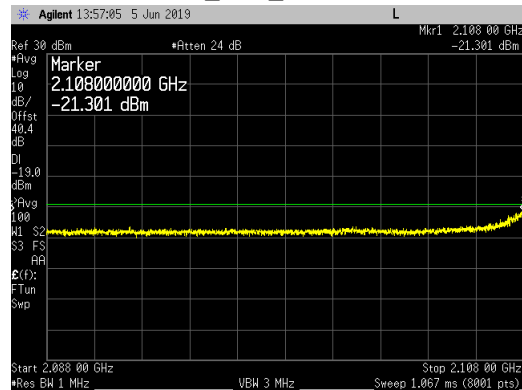

Top Channel\_ UBE\_ 2202 to 2222MHz

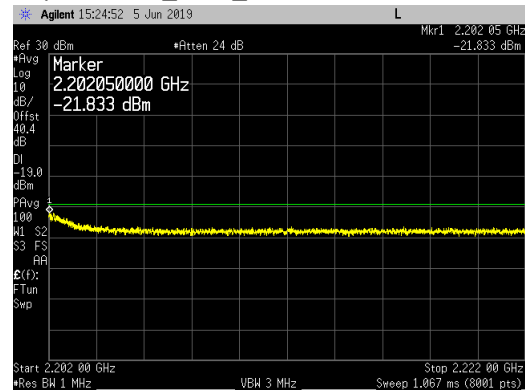

Single Carrier LTE3 Band Edge Plots for Antenna Port 3 and 256QAM Modulation:

Bottom Channel\_ LBE\_ 2109 to 2131MHz

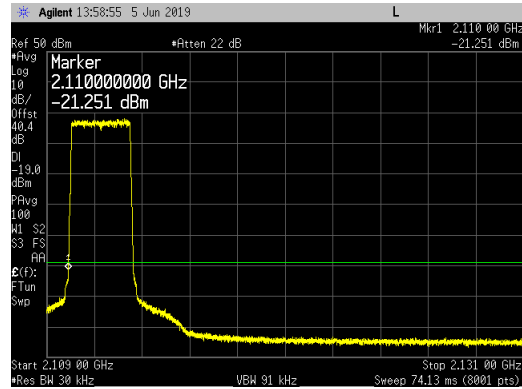

Top Channel\_ UBE\_ 2179 to 2201MHz

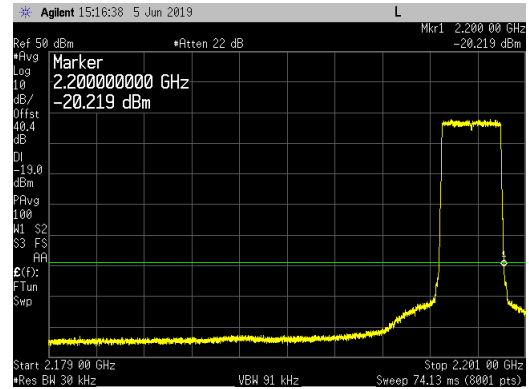

Bottom Channel\_ LBE\_ 2108 to 2109MHz

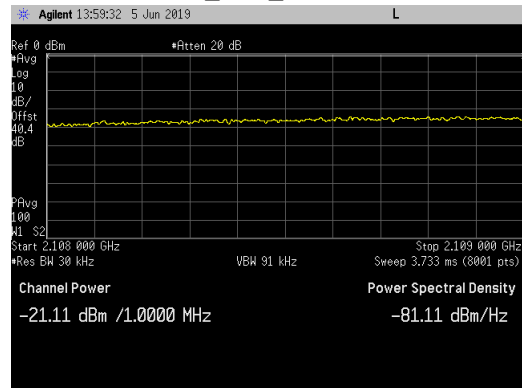

Top Channel\_ UBE\_ 2201 to 2202MHz

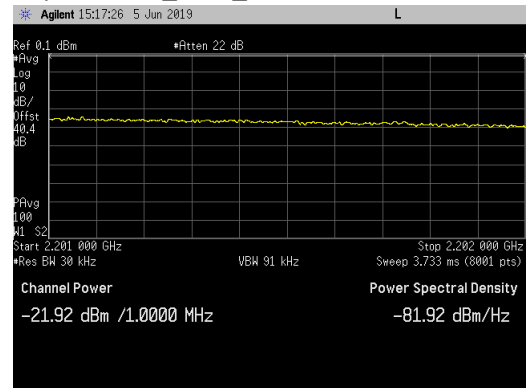

Bottom Channel\_ LBE\_ 2088 to 2108MHz

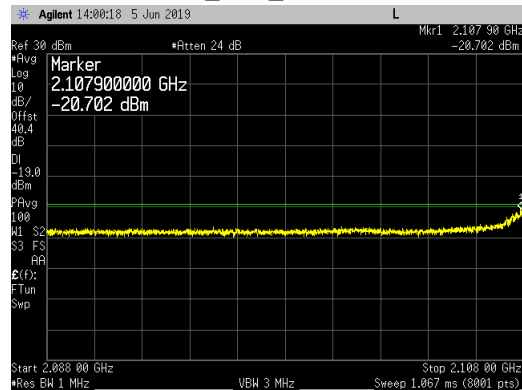

Top Channel\_ UBE\_ 2202 to 2222MHz

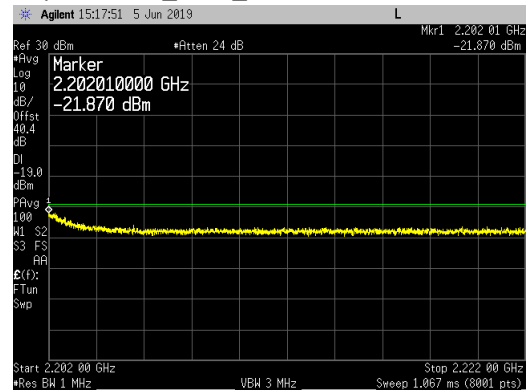

**Single Carrier LTE5 Band Edge Plots for Antenna Port 3 and QPSK Modulation:**

Bottom Channel\_ LBE\_ 2109 to 2131MHz

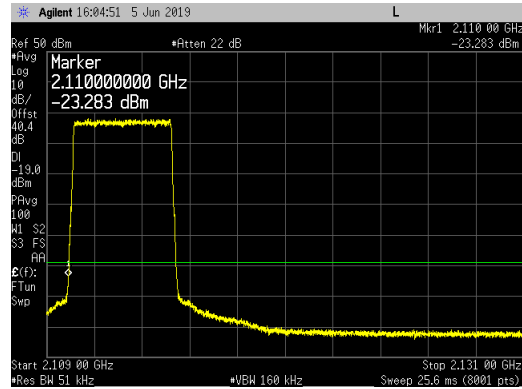

Top Channel\_ UBE\_ 2179 to 2201MHz

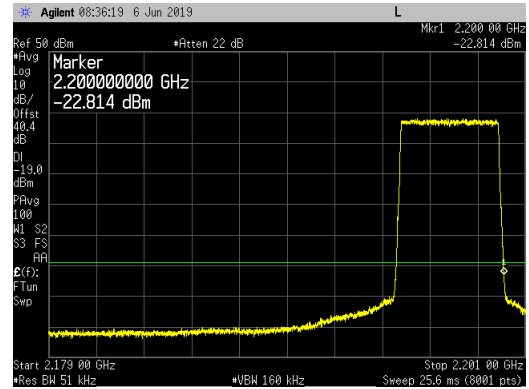

Bottom Channel\_ LBE\_ 2108 to 2109MHz

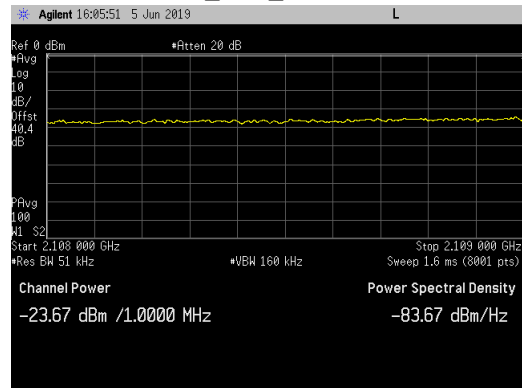

Top Channel\_ UBE\_ 2201 to 2202MHz

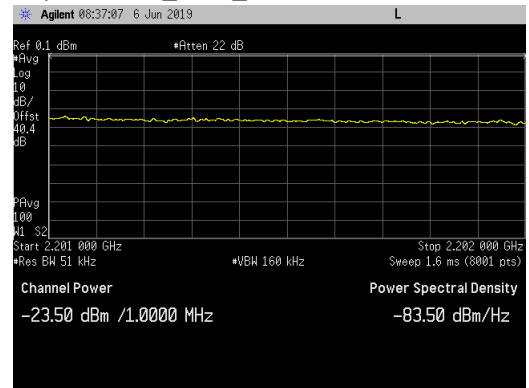

Bottom Channel\_ LBE\_ 2088 to 2108MHz

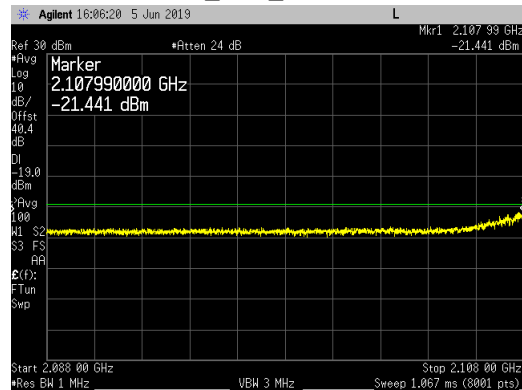

Top Channel\_ UBE\_ 2202 to 2222MHz

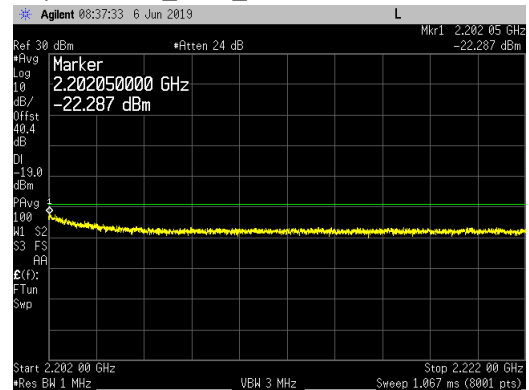

Single Carrier LTE5 Band Edge Plots for Antenna Port 3 and 16QAM Modulation:

Bottom Channel\_ LBE\_ 2109 to 2131MHz

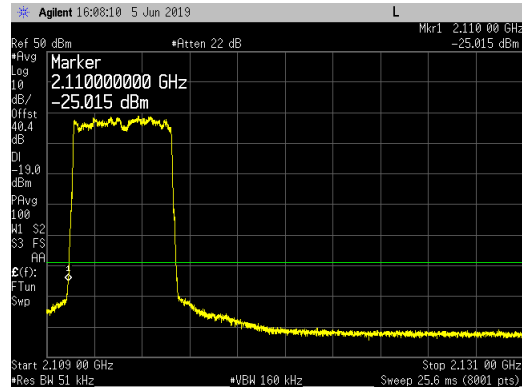

Top Channel\_ UBE\_ 2179 to 2201MHz

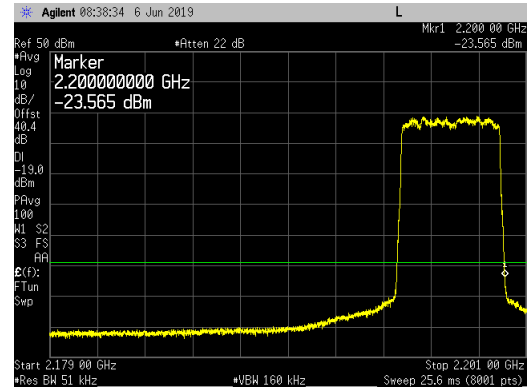

Bottom Channel\_ LBE\_ 2108 to 2109MHz

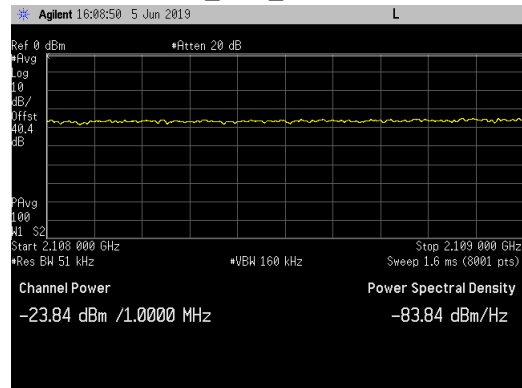

Top Channel\_ UBE\_ 2201 to 2202MHz

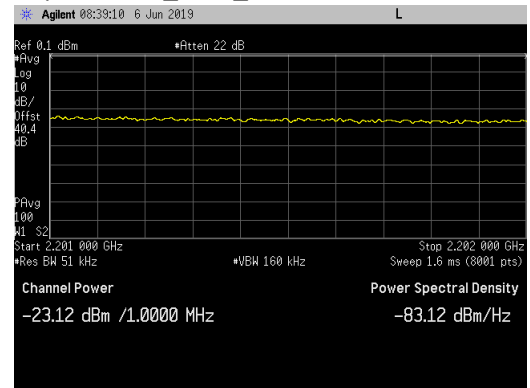

Bottom Channel\_ LBE\_ 2088 to 2108MHz

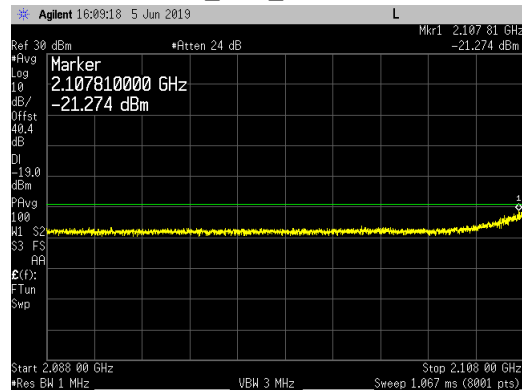

Top Channel\_ UBE\_ 2202 to 2222MHz

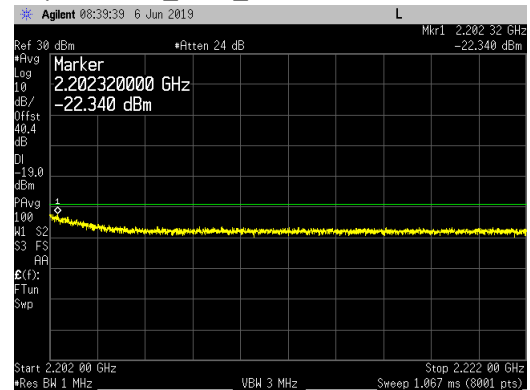

Single Carrier LTE5 Band Edge Plots for Antenna Port 3 and 64QAM Modulation:

Bottom Channel\_ LBE\_ 2109 to 2131MHz

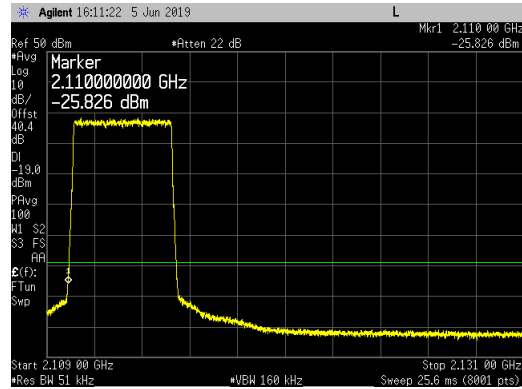

Top Channel\_ UBE\_ 2179 to 2201MHz

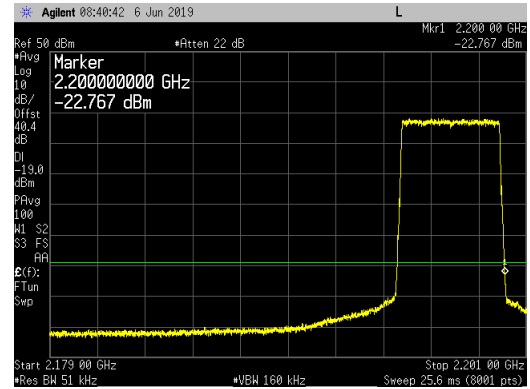

Bottom Channel\_ LBE\_ 2108 to 2109MHz

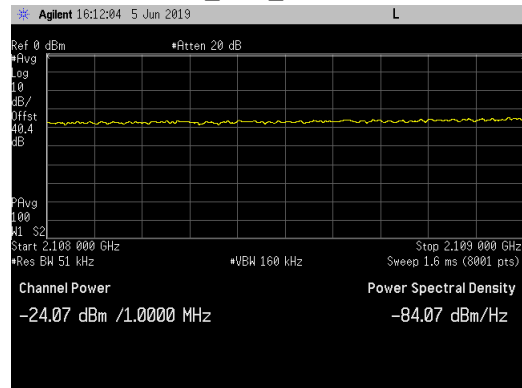

Top Channel\_ UBE\_ 2201 to 2202MHz

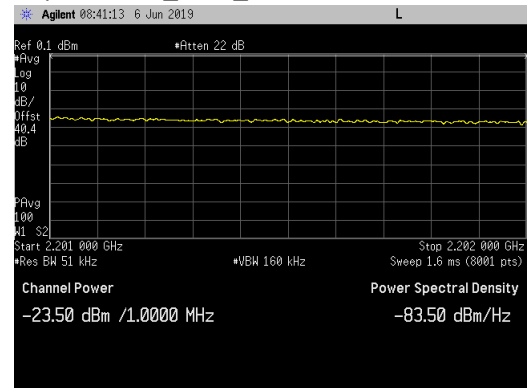

Bottom Channel\_ LBE\_ 2088 to 2108MHz

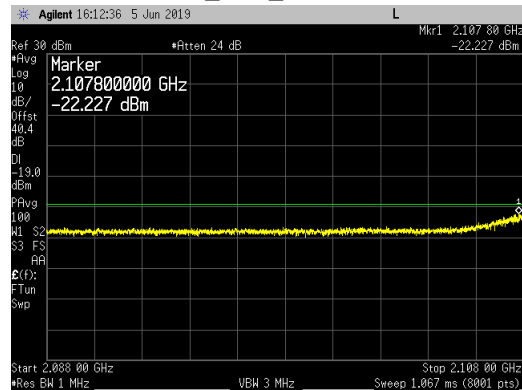

Top Channel\_ UBE\_ 2202 to 2222MHz

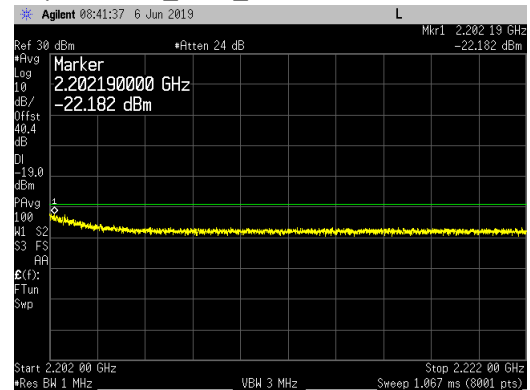

Single Carrier LTE5 Band Edge Plots for Antenna Port 3 and 256QAM Modulation:

Bottom Channel\_ LBE\_ 2109 to 2131MHz

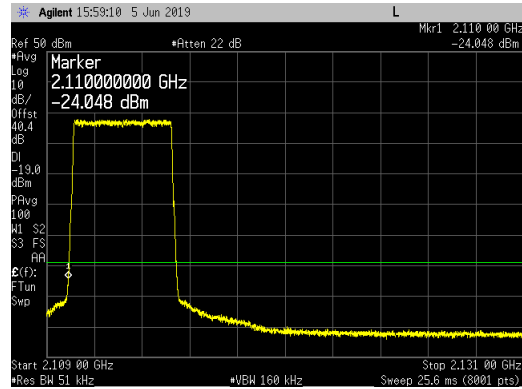

Top Channel\_ UBE\_ 2179 to 2201MHz

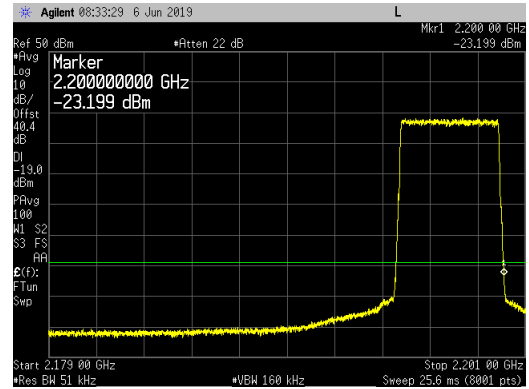

Bottom Channel\_ LBE\_ 2108 to 2109MHz

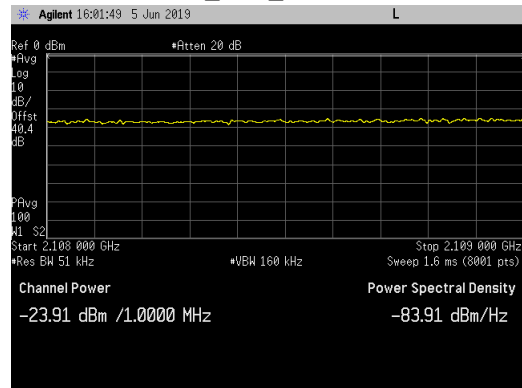

Top Channel\_ UBE\_ 2201 to 2202MHz

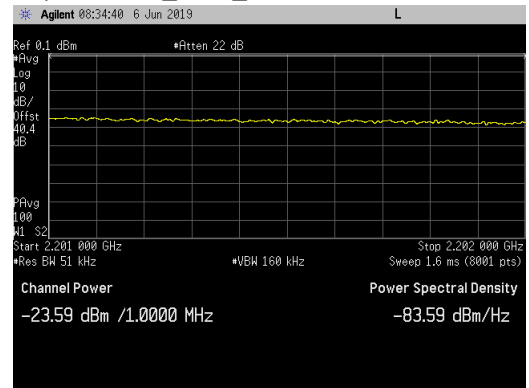

Bottom Channel\_ LBE\_ 2088 to 2108MHz

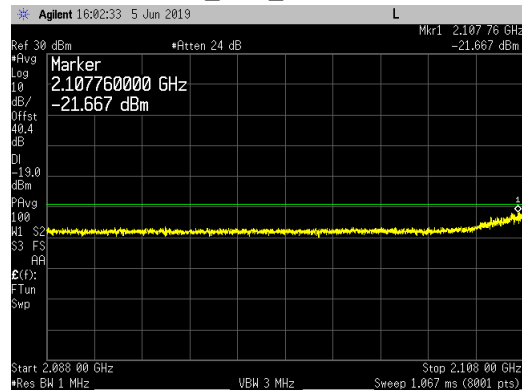

Top Channel\_ UBE\_ 2202 to 2222MHz

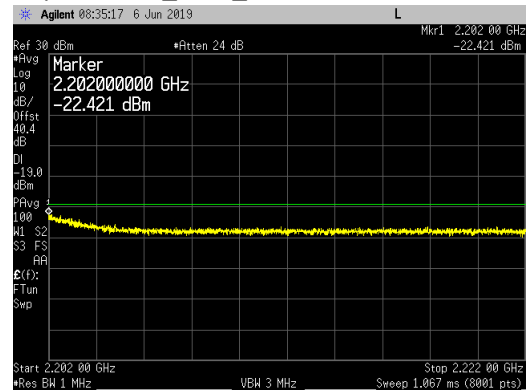

Single Carrier LTE10 Band Edge Plots for Antenna Port 3 and QPSK Modulation:

Bottom Channel\_ LBE\_ 2109 to 2131MHz

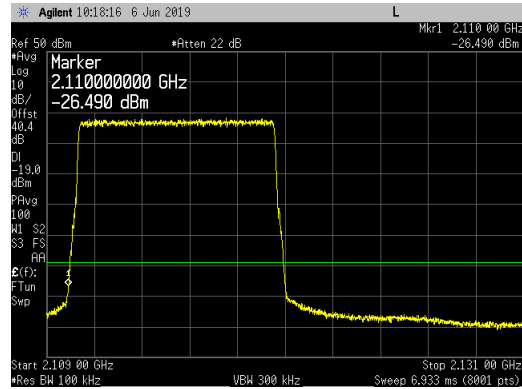

Top Channel\_ UBE\_ 2179 to 2201MHz

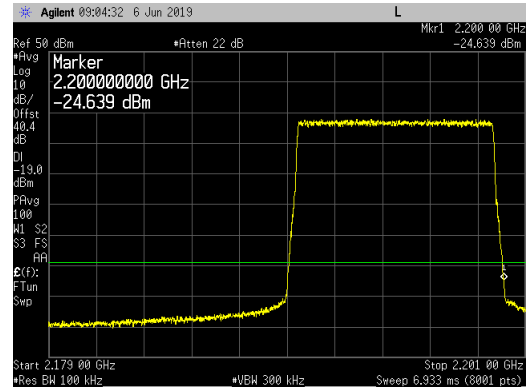

Bottom Channel\_ LBE\_ 2108 to 2109MHz

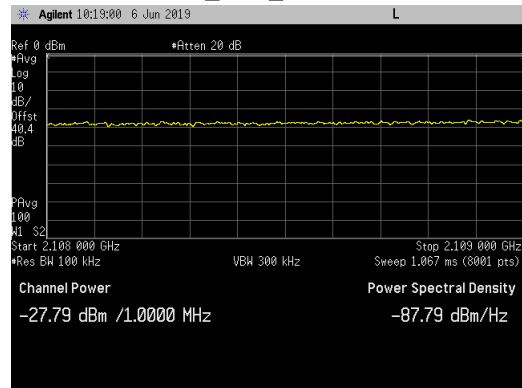

Top Channel\_ UBE\_ 2201 to 2202MHz

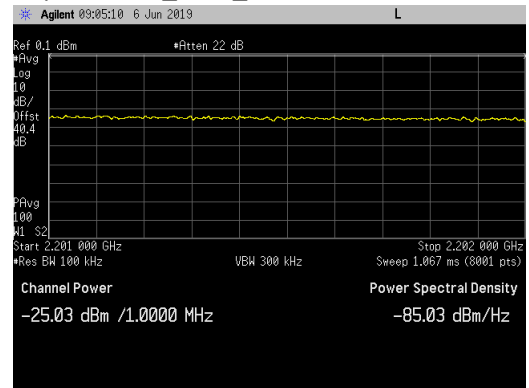

Bottom Channel\_ LBE\_ 2088 to 2108MHz

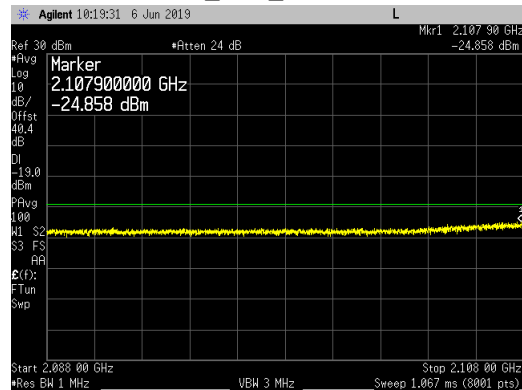

Top Channel\_ UBE\_ 2202 to 2222MHz

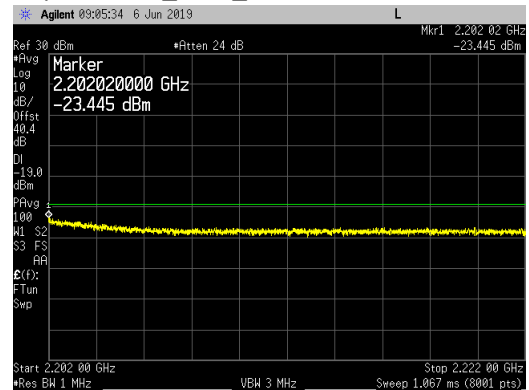



Single Carrier LTE10 Band Edge Plots for Antenna Port 3 and 16QAM Modulation:

Bottom Channel\_ LBE\_ 2109 to 2131MHz

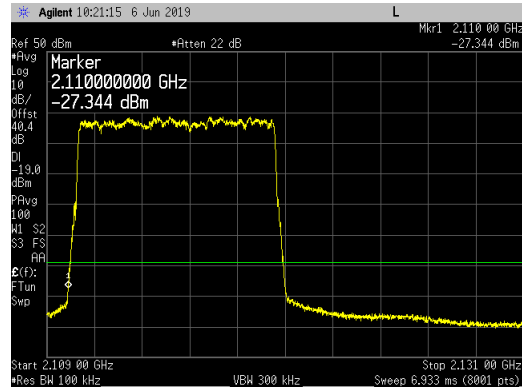

Top Channel\_ UBE\_ 2179 to 2201MHz

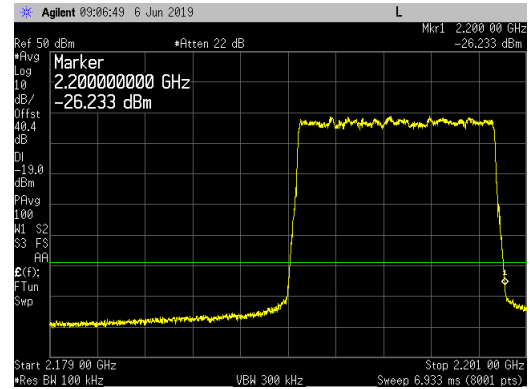

Bottom Channel\_ LBE\_ 2108 to 2109MHz

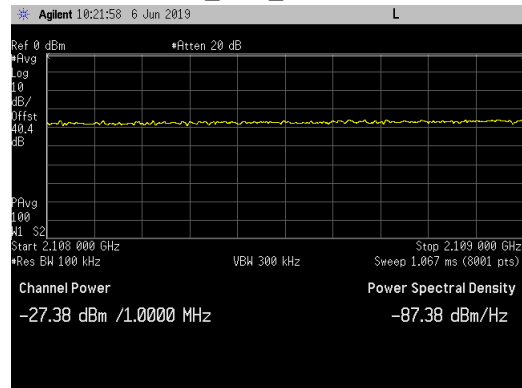

Top Channel\_ UBE\_ 2201 to 2202MHz

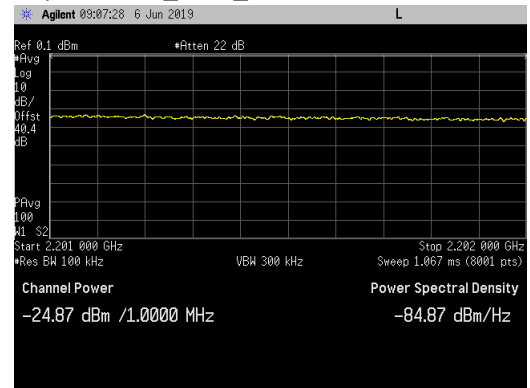

Bottom Channel\_ LBE\_ 2088 to 2108MHz

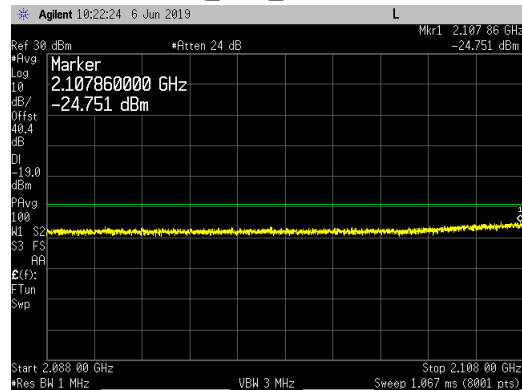

Top Channel\_ UBE\_ 2202 to 2222MHz

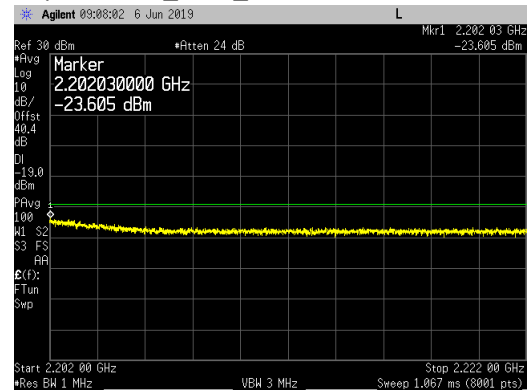

Single Carrier LTE10 Band Edge Plots for Antenna Port 3 and 64QAM Modulation:

Bottom Channel\_ LBE\_ 2109 to 2131MHz

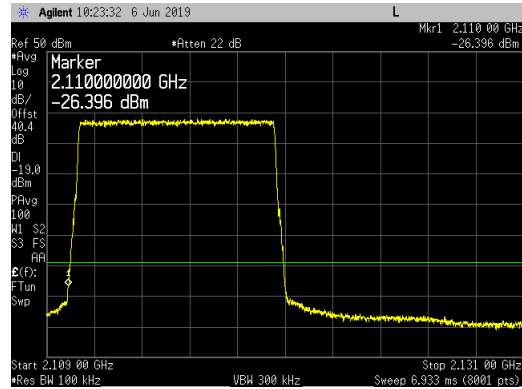

Top Channel\_ UBE\_ 2179 to 2201MHz

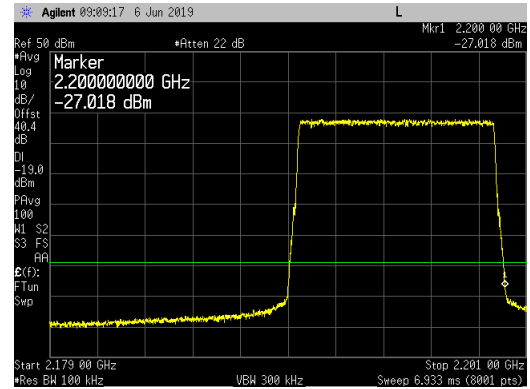

Bottom Channel\_ LBE\_ 2108 to 2109MHz

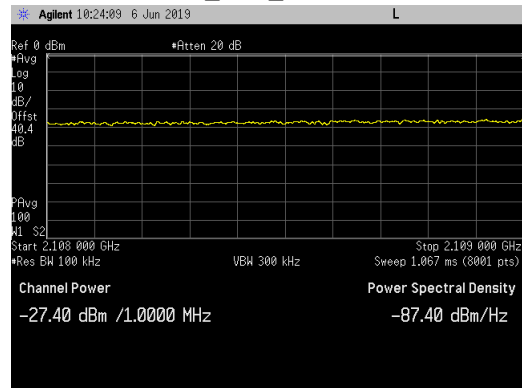

Top Channel\_ UBE\_ 2201 to 2202MHz

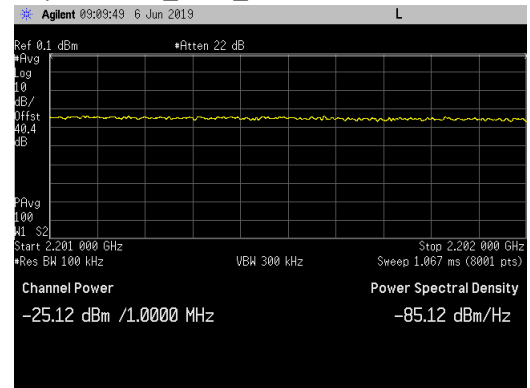

Bottom Channel\_ LBE\_ 2088 to 2108MHz

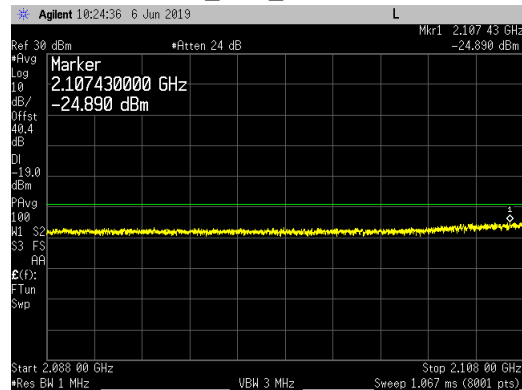

Top Channel\_ UBE\_ 2202 to 2222MHz

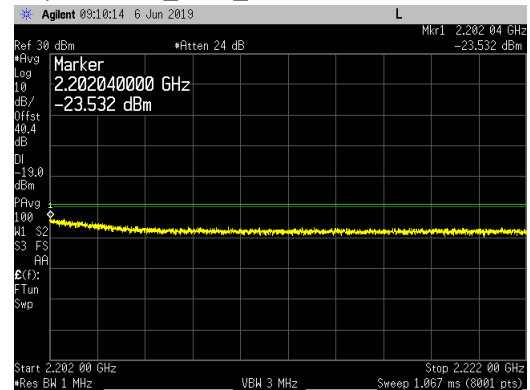

Single Carrier LTE10 Band Edge Plots for Antenna Port 3 and 256QAM Modulation:

Bottom Channel\_ LBE\_ 2109 to 2131MHz

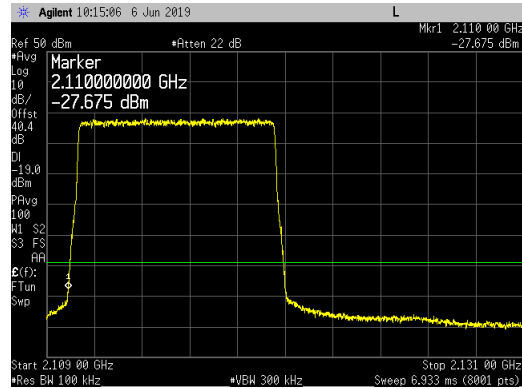

Top Channel\_ UBE\_ 2179 to 2201MHz

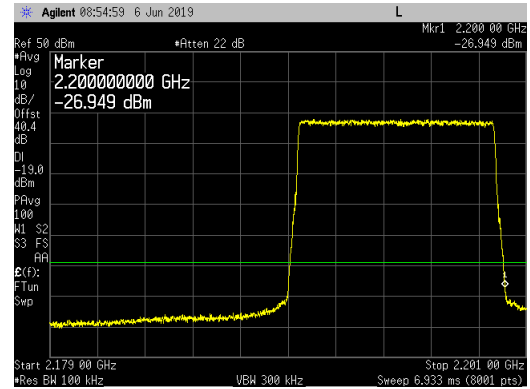

Bottom Channel\_ LBE\_ 2108 to 2109MHz

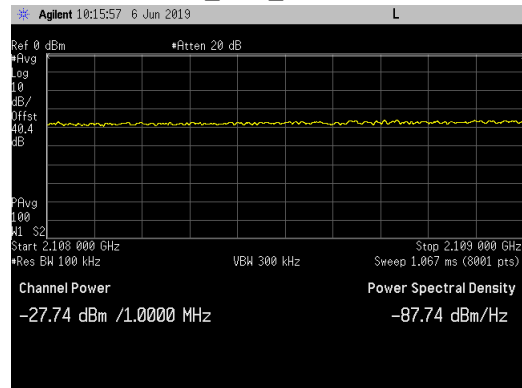

Top Channel\_ UBE\_ 2201 to 2202MHz

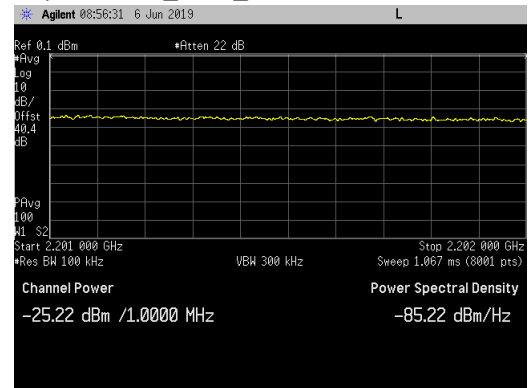

Bottom Channel\_ LBE\_ 2088 to 2108MHz

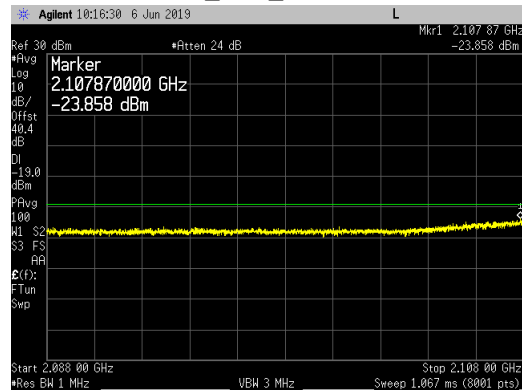

Top Channel\_ UBE\_ 2202 to 2222MHz

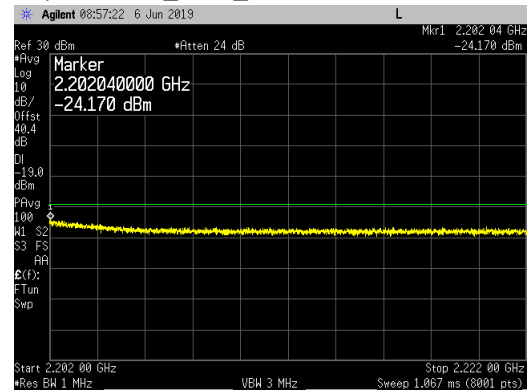

Single Carrier LTE15 Band Edge Plots for Antenna Port 3 and QPSK Modulation:

Bottom Channel\_ LBE\_ 2109 to 2131MHz

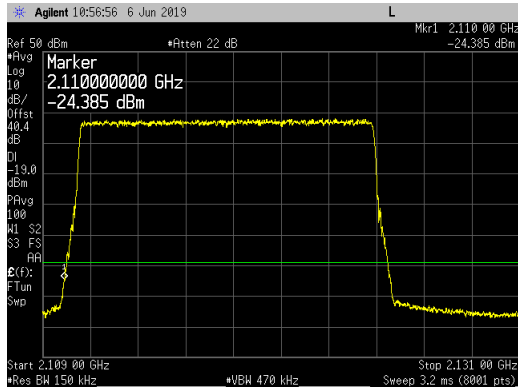

Top Channel\_ UBE\_ 2179 to 2201MHz

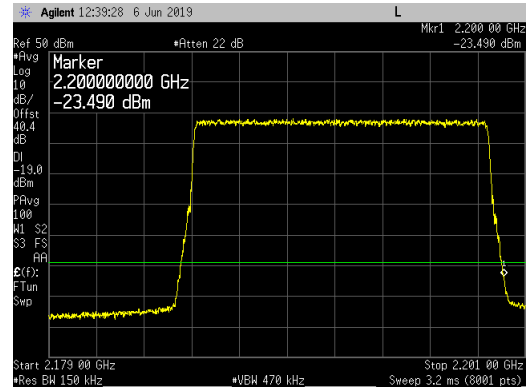

Bottom Channel\_ LBE\_ 2108 to 2109MHz

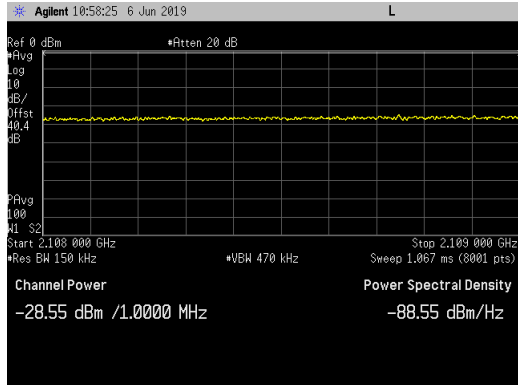

Top Channel\_ UBE\_ 2201 to 2202MHz

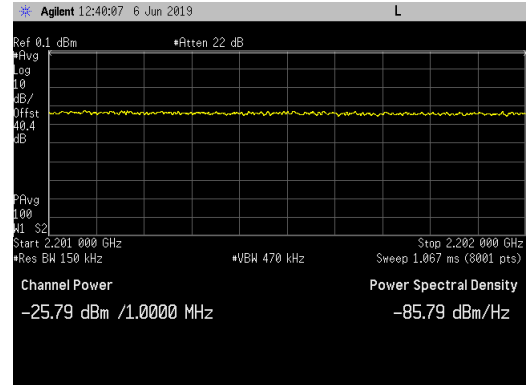

Bottom Channel\_ LBE\_ 2088 to 2108MHz

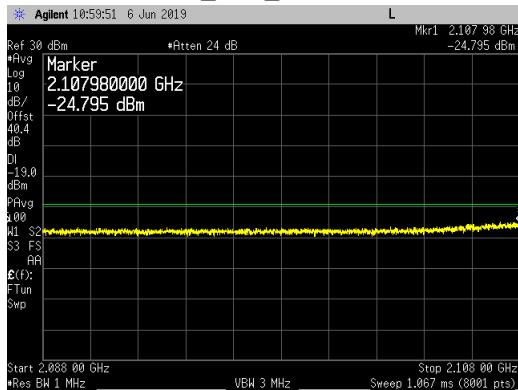

Top Channel\_ UBE\_ 2202 to 2222MHz

