

## EMC TEST REPORT for Intentional Radiator (Wi-Fi Function)

No. 140602015SHA-001

Applicant : Everflourish Electrical Co., Ltd.  
Renjiu Village, Wuxiang Town, Yinzhou, Ningbo,  
315111, P.R.China

Manufacturer : Everflourish Electrical Co., Ltd.  
Renjiu Village, Wuxiang Town, Yinzhou, Ningbo,  
315111, P.R.China

Product Name : Remote-control socket outlet

Trade Name :  EverFlourish

Type/Model : EMW302WF-UL

**TEST RESULT : Pass**

### SUMMARY

The equipment complies with the requirements according to the following standard(s):

**47CFR Part 15 (2013):** Radio Frequency Devices

**ANSI C63.4 (2009):** American National Standard for Methods of Measurement of Radio-Noise Emissions from Low-Voltage Electrical and Electronic Equipment in the Range of 9 kHz to 40 GHz

**RSS-210 Issue 8 (December 2010):** Low-power Licence-exempt Radio communication Devices (All Frequency Bands): Category I Equipment

**RSS-Gen Issue 3 (December 2010):** General Requirements and Information for the Certification of Radio communication Equipment

Date of issue: Jul 23, 2014

Prepared by:



Wade Zhang (Project engineer)

Reviewed by:

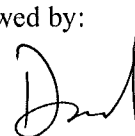

Daniel Zhao (Reviewer)



**FCC ID: VBA-EF302WFUL**  
**IC: 7098A-EF302WFUL**

## **Description of Test Facility**

Name: Intertek Testing Services Limited Shanghai  
Address: Building 86, No. 1198 Qinzhou Rd., North, Shanghai 200233, P.R. China

FCC Registration Number: 236597  
IC Assigned Code: 2042B-1

Name of contact: Jonny Jing  
Tel: +86 21 61278271  
Fax: +86 21 54262353

## Content

<b>SUMMARY</b> .....	<b>1</b>
<b>DESCRIPTION OF TEST FACILITY</b> .....	<b>2</b>
<b>1. GENERAL INFORMATION</b> .....	<b>4</b>
1.1 Applicant Information.....	4
1.2 Identification of the EUT .....	4
1.3 Technical specification .....	5
1.4 Mode of operation during the test / Test peripherals used.....	5
<b>2. TEST SPECIFICATION</b> .....	<b>6</b>
2.1 Instrument list .....	6
2.2 Test Standard .....	6
2.3 Test Summary .....	7
<b>3. MINIMUM 6dB BANDWIDTH</b> .....	<b>8</b>
3.1 Limit.....	8
3.2 Test Configuration .....	8
3.3 Test Procedure and test setup.....	8
3.4 Test Protocol .....	9
<b>4. MAXIMUM PEAK OUTPUT POWER</b> .....	<b>15</b>
4.1 Test limit .....	15
4.2 Test Configuration .....	15
4.3 Test procedure and test setup.....	15
4.4 Test protocol .....	16
<b>5. POWER SPECTRUM DENSITY</b> .....	<b>17</b>
5.1 Test limit .....	17
5.2 Test Configuration .....	17
5.3 Test procedure and test setup.....	17
5.4 Test Protocol .....	18
<b>6. RADIATED EMISSION</b> .....	<b>24</b>
6.1 Test limit .....	24
6.2 Test Configuration .....	24
6.3 Test procedure and test setup.....	25
6.4 Test protocol .....	26
<b>7. EMISSION OUTSIDE THE FREQUENCY BAND</b> .....	<b>31</b>
7.1 Limit.....	31
7.2 Test Configuration .....	31
7.3 Test procedure and test setup.....	31
7.4 Test protocol .....	32
<b>8. POWER LINE CONDUCTED EMISSION</b> .....	<b>55</b>
8.1 Limit.....	55
8.2 Test configuration .....	55
8.3 Test procedure and test set up.....	56
8.4 Test protocol .....	57



## **1. General Information**

### **1.1 Applicant Information**

Applicant : Everflourish Electrical Co., Ltd.  
Renjiu Village, Wuxiang Town, Yinzhou, Ningbo, 315111,  
P.R.China

Name of contact : Ms.Selina Dong

Tel : 0574-88330888

Fax : 0574-88330999

Email : dongsl@everflourish.com.cn

Manufacturer : Everflourish Electrical Co., Ltd.  
Renjiu Village, Wuxiang Town, Yinzhou, Ningbo, 315111,  
P.R.China

### **1.2 Identification of the EUT**

Product Name : Remote-control socket outlet

Type/model : EMW302WF-UL

FCC ID : VBA-EF302WFUL

IC : 7098A-EF302WFUL

### 1.3 Technical specification

Operation Frequency : 2412~2462 MHz  
Band  
Type of Modulation : CCK,BPSK,QPSK,DSSS,OFDM  
EUT Modes of : 802.11b/g;  
Modulation : 802.11n HT20  
Channel Number : 11Channel for 2412MHz~2462MHz for 11b,11g,11n HT20  
Description of EUT : The EUT is a wireless remote-control socket outlet, and it has only one model.  
Port identification : NA  
Antenna : Integral 2.0dBi  
Rating : DC 12V, 1A (Adaptor) or DC 57V, 350 mA(PoE)  
Declared Temperature : 0°C ~ 30°C  
range  
Category of EUT : Class B  
EUT type :  Table top  Floor standing  
Sample received date : Jun.27, 2014  
Sample Identification : 0140627-23-005  
No  
Date of test : Jun.28, 2014 – Jul.23, 2014

### 1.4 Mode of operation during the test / Test peripherals used

While testing transmitting mode of EUT, the internal modulation and continuously transmission was applied.

The lowest, middle and highest channel were tested as representatives.  
802.11b/g/n(HT20):2412MHz,2437MHz,2462MHz.

The test setting software for 802.11b/g/n (HT20) is offered by the manufactory.

The pre-scan for the conducted power with all rates in each modulation and bands was used, and the worst case was found and used in all test cases.

After this pre-scan, we choose the following table of the data rata as the worst case.  
802.11b: 11Mbps; 802.11g: 1Mbps; 802.11 n (HT20): MCS0.

Test peripherals used:

Laptop computer HP ProBook 6470b, 100-240V AC 50/60Hz.

## 2. Test Specification

### 2.1 Instrument list

Equipment	Type	Manu.	Internal no.	Cal. Date	Due date
Test Receiver	ESCS 30	R&S	EC 2107	2013-10-21	2014-10-20
Test Receiver	ESIB 26	R&S	EC 3045	2013-10-20	2014-10-19
Test Receiver	ESCI 7	R&S	EC4501	2013-12-29	2014-12-28
Spectrum Analyzer	N9010	Agilent	EC4890	2013-10-21	2014-10-20
Spectrum Analyzer	E4446	Agilent	/	2013-10-21	2014-10-20
Power meter	ML 2495A	Anritsu	EC 4895	2013-10-21	2014-10-20
A.M.N.	ESH2-Z5	R&S	EC 3119	2014-1-9	2015-1-8
Bilog Antenna	CBL 6112D	TESEQ	EC 4206	2014-5-15	2015-5-14
Horn antenna	HF 906	R&S	EC 3049	2014-5-12	2015-5-11
Pre-amplifier	Pre-amp 18	R&S	EC 3222	2014-4-11	2015-4-10
Pre-amplifier	Tpa0118-40	R&S	EC 4792-2	2014-4-11	2015-4-10
Log-period antenna	AT 1080	AR	EC 3044-7	2014-5-21	2015-5-20
Biconical antenna	3109PX	ETS	EC3564	2013-8-25	2014-8-24
Semi-anechoic chamber	-	Albatross project	EC 3048	2014-5-20	2015-5-19
Shielded room	-	Zhongyu	EC 2838	2014-1-12	2015-1-9
Shielded room	-	Zhongyu	EC 2839	2014-1-12	2015-1-9
High Pass Filter	WHKX 1.0/15G-10SS	Wainwright	EC4297-1	2014-2-1	2015-1-31
High Pass Filter	WHKX 2.8/18G-12SS	Wainwright	EC4297-2	2014-2-1	2015-1-31
High Pass Filter	WHKX 7.0/1.8G-8SS	Wainwright	EC4297-3	2014-2-1	2015-1-31
Band Reject Filter	WRCGV 2400/2483- 2390/2493- 35/10SS	Wainwright	EC4297-4	2014-2-1	2015-1-31

### 2.2 Test Standard

47CFR Part 15 (2013)  
ANSI C63.4 (2009)  
KDB 558074 (V03R02)  
RSS-210 Issue 8 (December 2010)  
RSS-Gen Issue 3 (December 2010)

### 2.3 Test Summary

**This report applies to tested sample only. This report shall not be reproduced in part without written approval of Intertek Testing Service Shanghai.**

TEST ITEM	FCC REFERANCE	IC REFERANCE	RESULT
Minimum 6dB Bandwidth	15.247(a)(2)	RSS-210 Issue 8 Annex 8	Pass
Maximum peak output power	15.247(b)	RSS-210 Issue 8 Annex 8	Pass
Power spectrum density	15.247(e)	RSS-210 Issue 8 Annex 8	Pass
Radiated emission	15.205 & 15.209	RSS-210 Issue 8 Clause 2	Pass
Emission outside the frequency band	15.247(d)	RSS-210 Issue 8 Annex 8	Pass
Power line conducted emission	15.207	RSS-Gen Issue 3 Clause 7.2.4	Pass

### 3. Minimum 6dB Bandwidth

Test result: PASS

#### 3.1 Limit

For systems using digital modulation techniques that may operate in the 902 - 928 MHz, 2400 - 2483.5 MHz and 5725 - 5850 MHz bands, the minimum 6 dB bandwidth shall be at least 500 kHz.

#### 3.2 Test Configuration

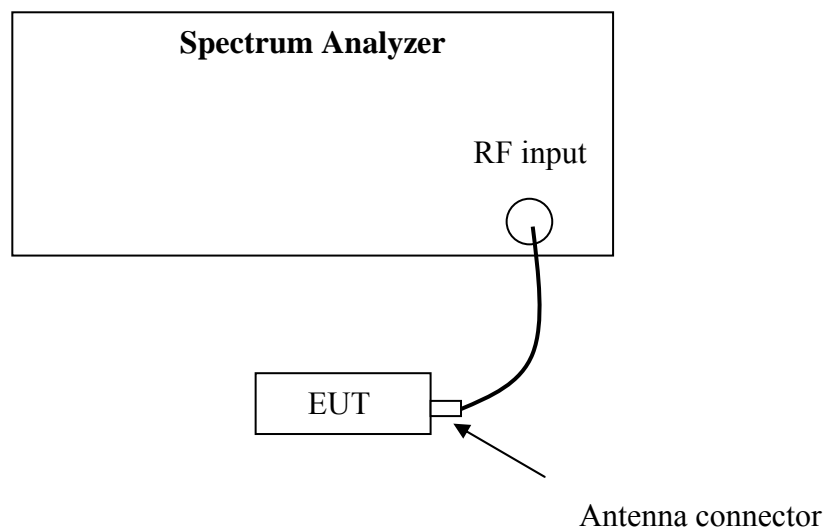

#### 3.3 Test Procedure and test setup

The minimum 6dB bandwidth per FCC § 15.247(a)(2) is measured using the Spectrum Analyzer according to DTS test procedure of "KDB558074 D01 DTS Meas Guidance v03r02" for compliance to FCC 47CFR 15.247 requirements(clause 8.2).



### 3.4 Test Protocol

Temperature : 25°C  
Relative Humidity : 55%

Mode	CH	Bandwidth (MHz)	Limit (MHz)
802.11b	L	10.02	≥0.5
	M	10.08	
	H	10.08	

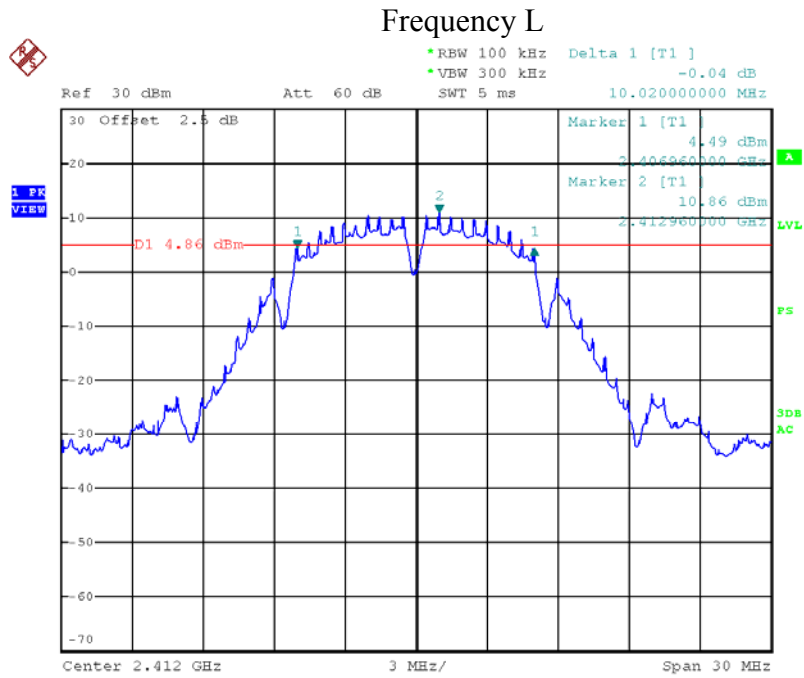

Date: 11.JUL.2014 15:23:15

**Frequency M**

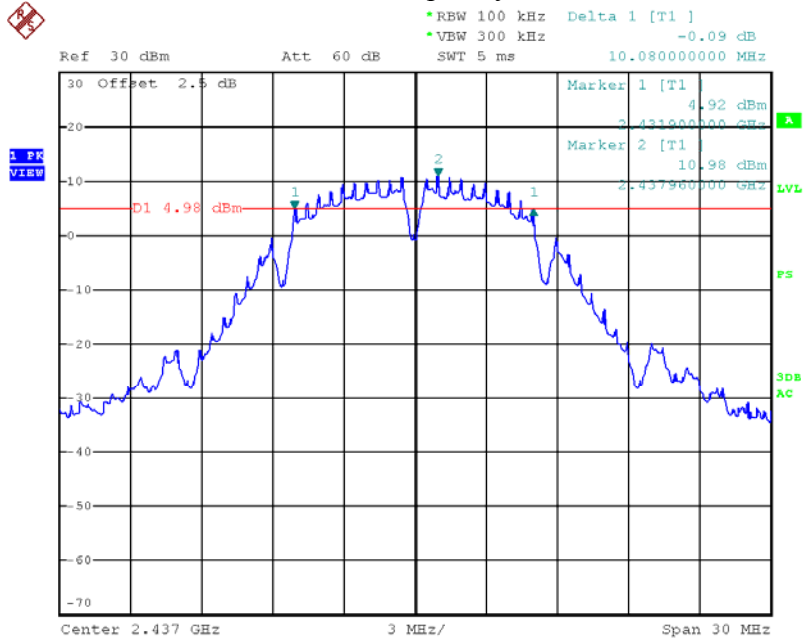

Date: 11.JUL.2014 15:25:08

**Frequency H**

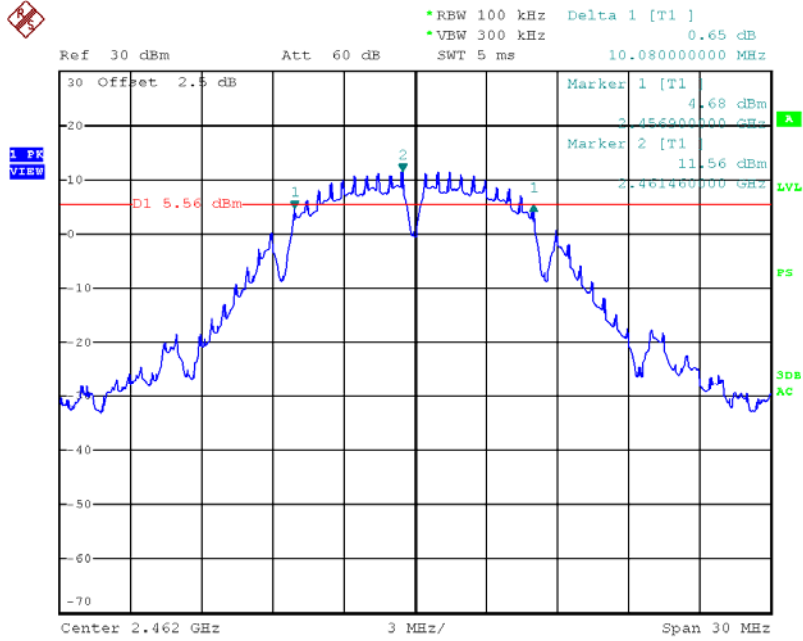

Date: 11.JUL.2014 15:27:46

Mode	CH	Bandwidth (MHz)	Limit (MHz)
802.11g	L	16.50	≥0.5
	M	16.50	
	H	16.44	

Frequency L

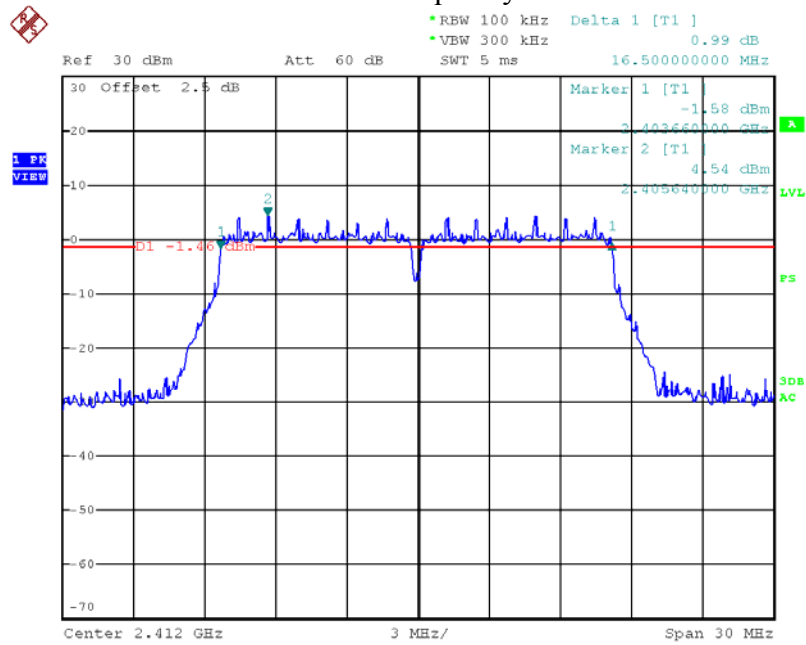

Date: 11.JUL.2014 15:31:17

**Frequency M**

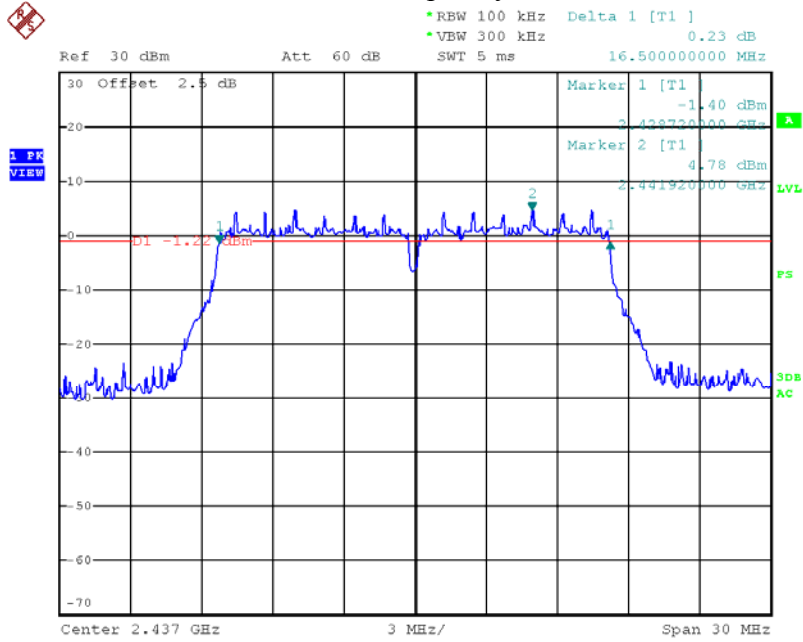

Date: 11.JUL.2014 15:33:16

**Frequency H**

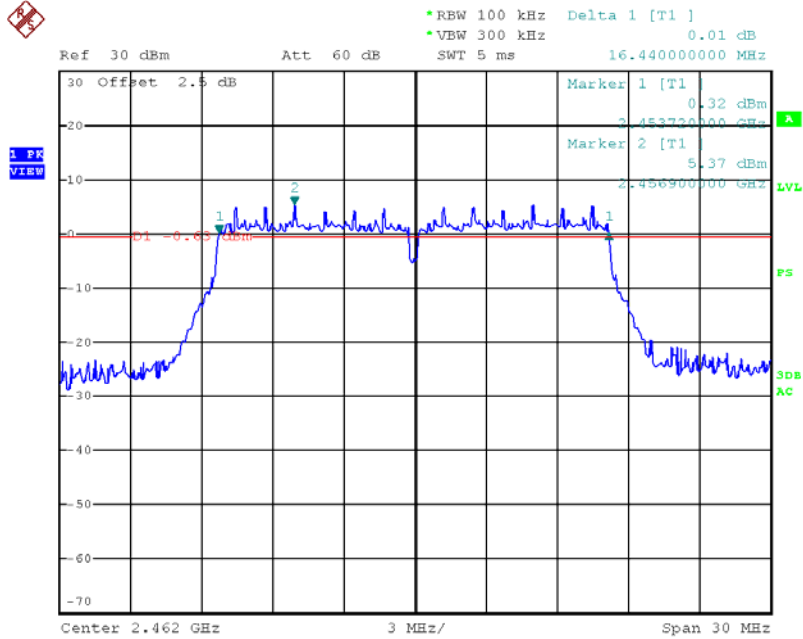

Date: 11.JUL.2014 15:35:36

Mode	CH	Bandwidth (MHz)	Limit (MHz)
802.11n(HT20)	L	17.04	≥0.5
	M	17.34	
	H	17.52	

### Frequency L

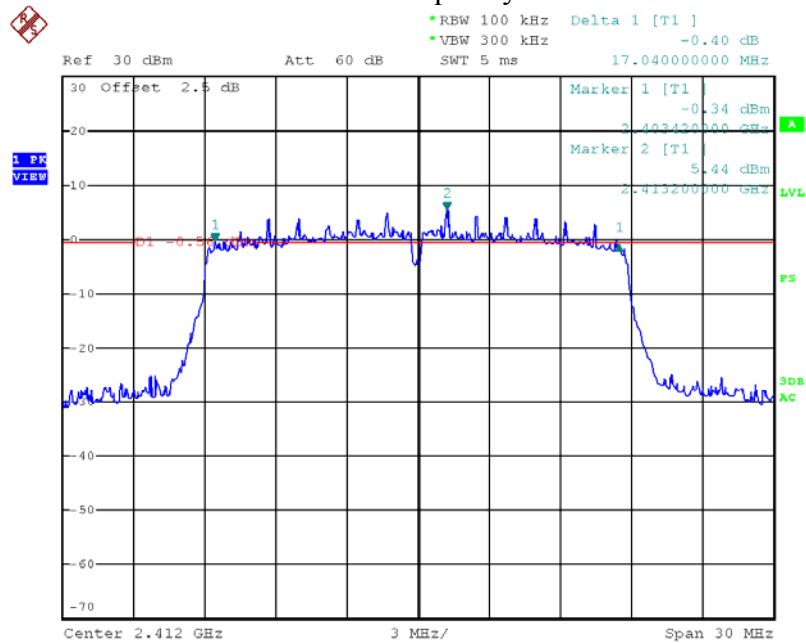

Date: 11.JUL.2014 15:45:29

**Frequency M**

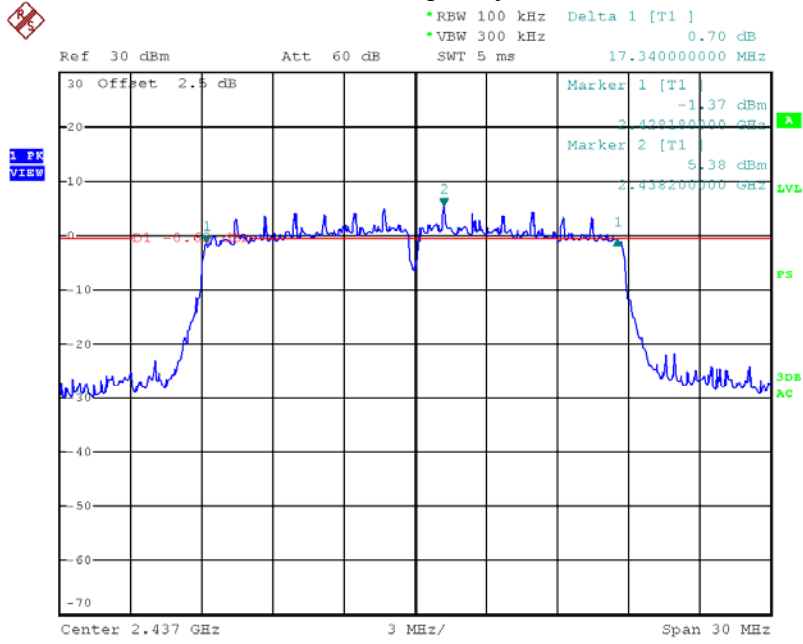

Date: 11.JUL.2014 15:48:16

**Frequency H**

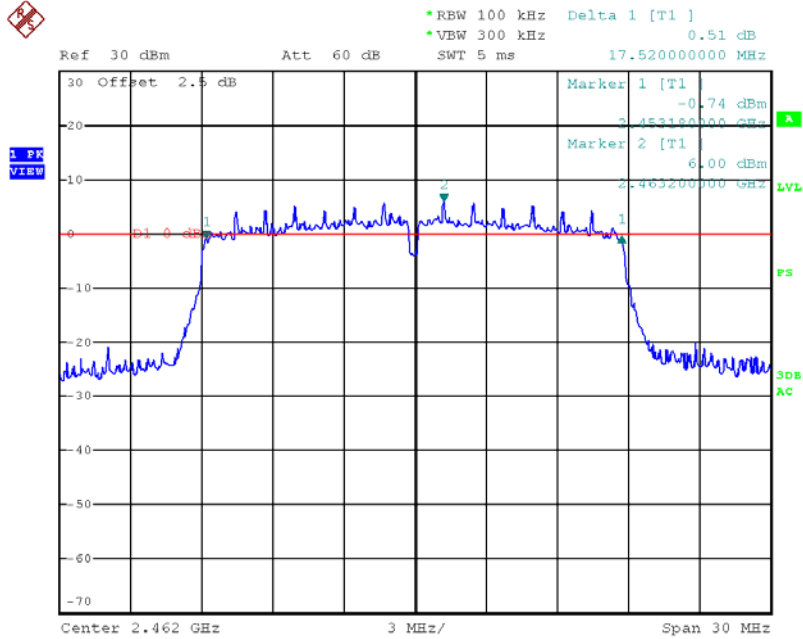

Date: 11.JUL.2014 15:51:10

#### 4. Maximum peak output power

Test result: PASS

##### 4.1 Test limit

- For frequency hopping systems operating in the 2400-2483.5 MHz band employing at least 75 non-overlapping hopping channels, and all frequency hopping systems in the 5725-5850 MHz band: 1 watt
- For all other frequency hopping systems in the 2400-2483.5 MHz band: 0.125 watts
- For systems using digital modulation in the 902-928 MHz, 2400-2483.5 MHz, and 5725-5850 MHz bands: 1 Watt.

If the transmitting antenna of directional gain greater than 6dBi is used, the power shall be reduced by the amount in dB that the directional gain of the antenna exceeds 6dBi.

##### 4.2 Test Configuration

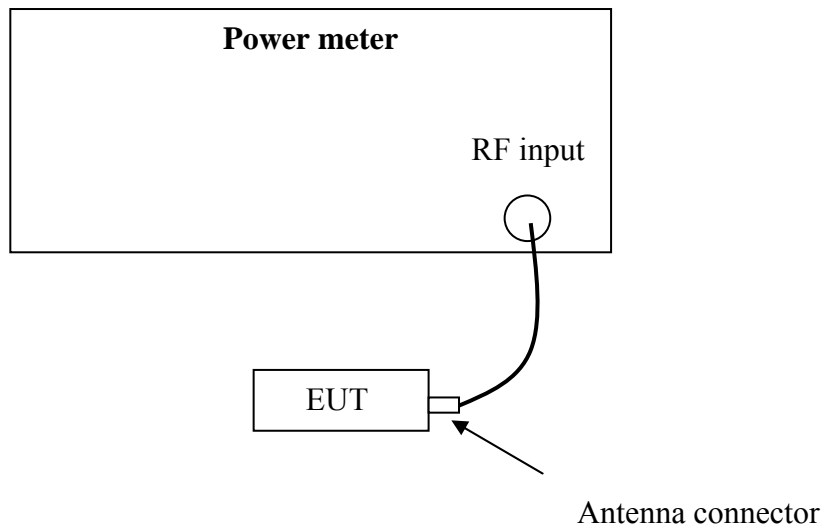

##### 4.3 Test procedure and test setup

The EUT was tested according to DTS test procedure of “KDB558074 D01 DTS Meas Guidance v03r02” for compliance to FCC 47CFR 15.247 requirements (clause 9.1.2).

#### 4.4 Test protocol

Temperature : 25°C  
Relative Humidity : 55%

Mode	Freq. (MHz)	Reading (dBm)	Limit (dBm)	Margin (dB)
802.11b	2412	20.07	30.00	9.93
	2437	20.12	30.00	9.88
	2462	20.03	30.00	9.97
802.11g	2412	17.79	30.00	12.21
	2437	17.85	30.00	12.15
	2462	17.45	30.00	12.55
802.11n(HT20)	2412	17.68	30.00	12.32
	2437	17.43	30.00	12.57
	2462	17.49	30.00	12.51

***The maximum EIRP of the EUT = 20.12dBm + 2.00dBi = 22.12dBm = 162.93mW which is lower than the EIRP limit of RSS-210.***



## 5. Power spectrum density

Test result: PASS

### 5.1 Test limit

For digitally modulated systems, the power spectral density conducted from the intentional radiator to the antenna shall not be greater than 8dBm in any 3 kHz band during any time interval of continuous transmission.

### 5.2 Test Configuration

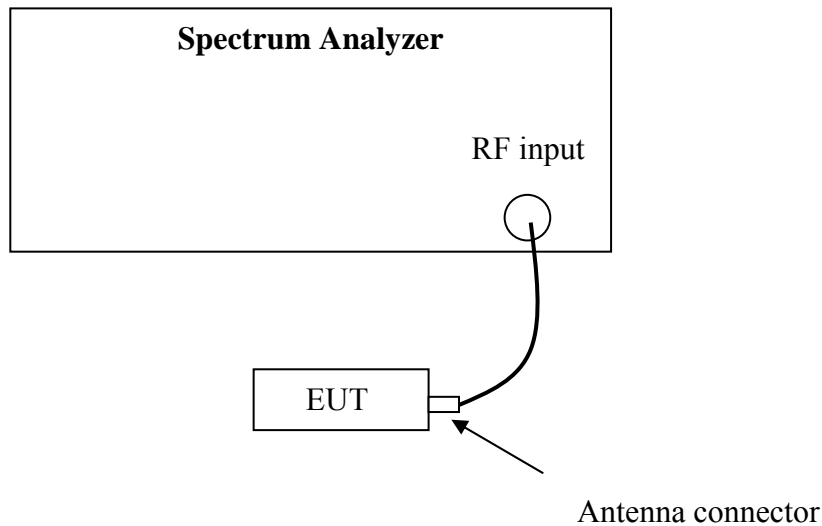

### 5.3 Test procedure and test setup

The power output per FCC § 15.247(e) was tested according to DTS test procedure of “KDB558074 D01 DTS Meas Guidance v03r02” (clause 10.2) for compliance to FCC 47CFR 15.247 requirements.

**5.4 Test Protocol**

Temperature : 25°C  
Relative Humidity : 55%

Mode	CH	PSD (dBm/3kHz)	Limit (dBm/3kHz)
802.11b	L	-3.23	≤8.00
	M	-2.95	
	H	-2.92	

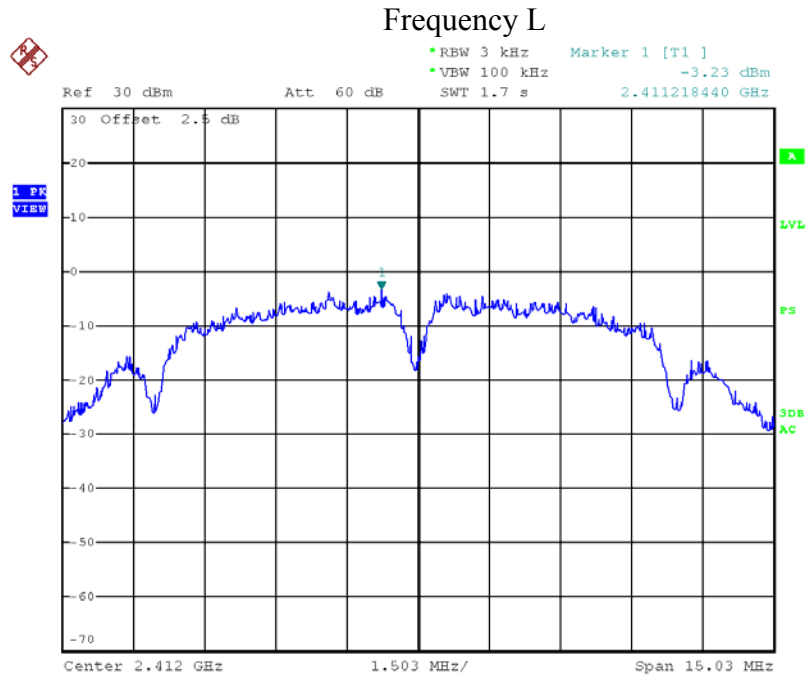

Date: 11.JUL.2014 16:23:22

### Frequency M

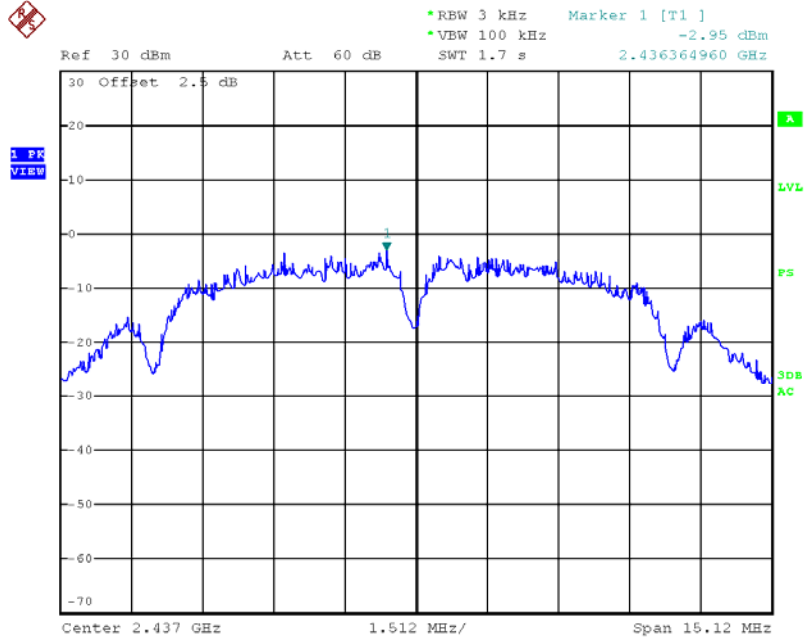

Date: 11.JUL.2014 16:25:50

### Frequency H

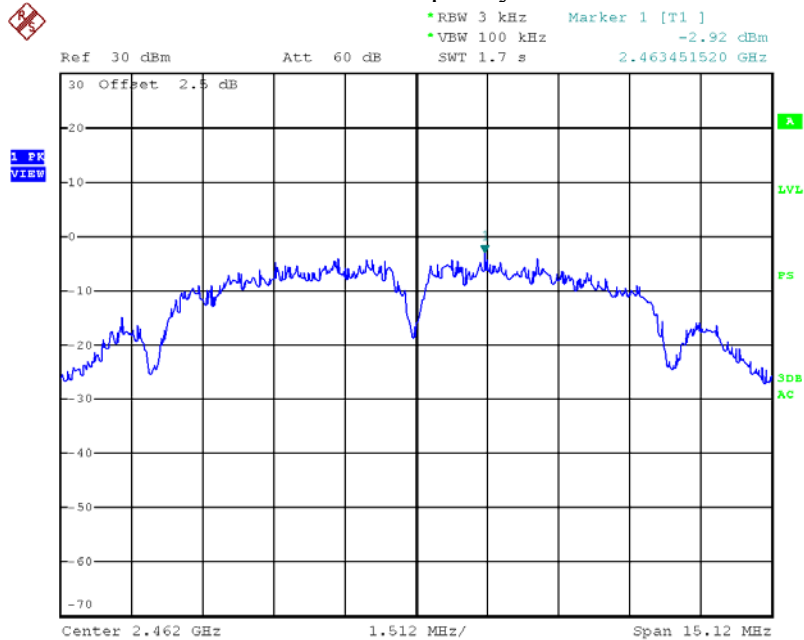

Date: 11.JUL.2014 16:27:14

Mode	CH	PSD (dBm/3kHz)	Limit (dBm/3kHz)
802.11g	L	-7.14	≤8.00
	M	-9.08	
	H	-9.53	

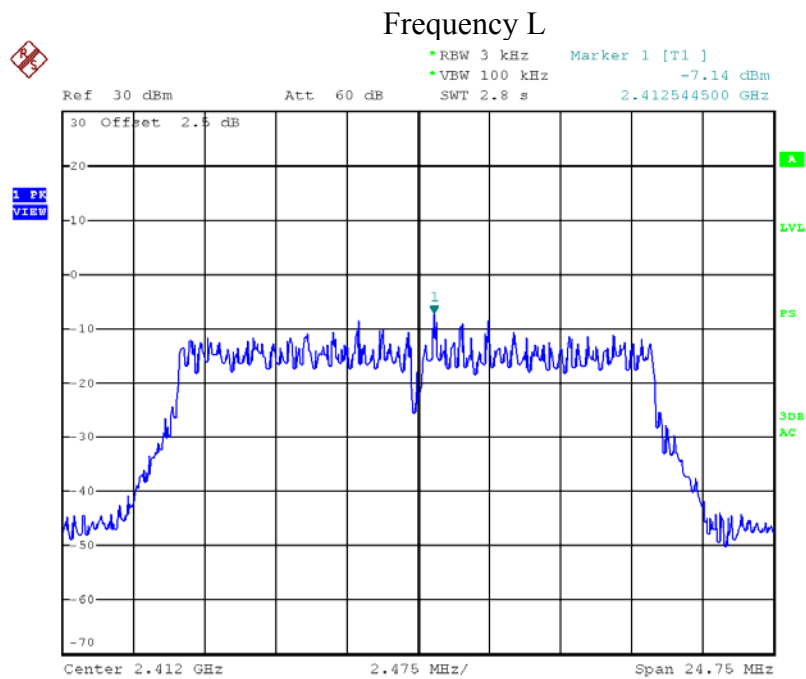

Date: 11.JUL.2014 16:33:09

### Frequency M

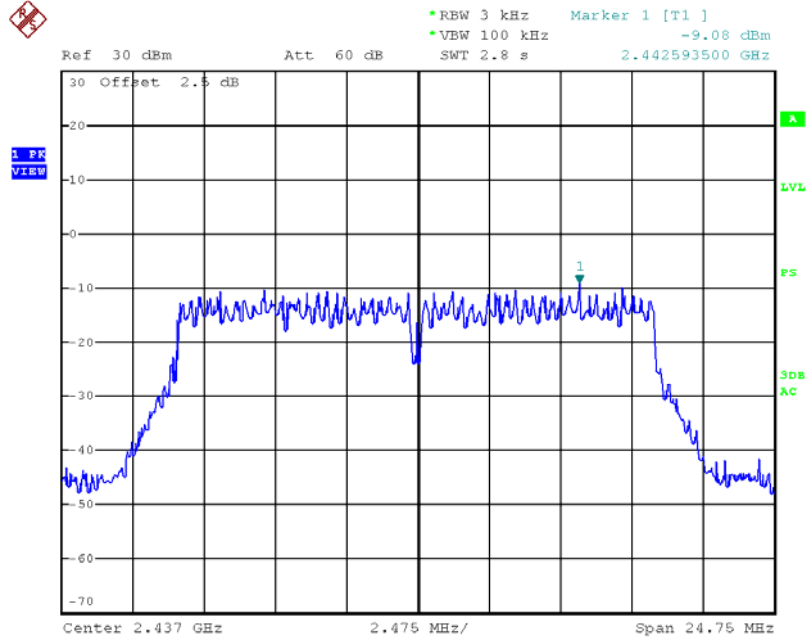

Date: 11.JUL.2014 16:35:06

### Frequency H

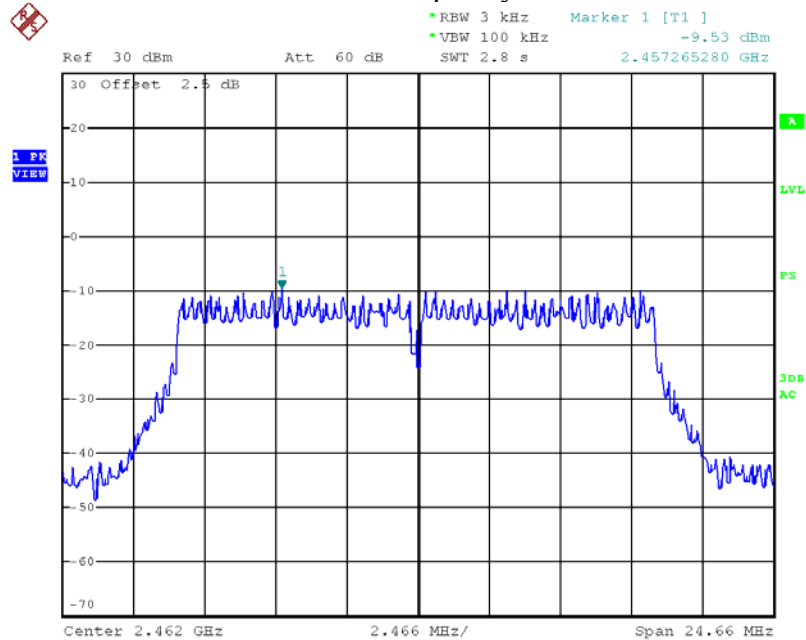

Date: 11.JUL.2014 16:38:18

Mode	CH	PSD (dBm/3kHz)	Limit (dBm/3kHz)
802.11n(HT20)	L	-9.08	≤8.00
	M	-9.11	
	H	-7.19	

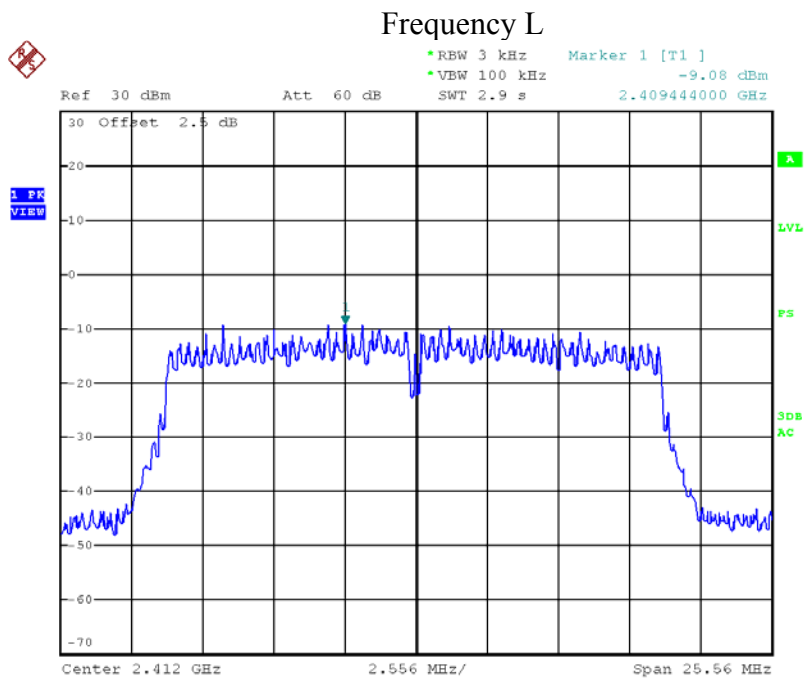

Date: 11.JUL.2014 16:40:54

### Frequency M

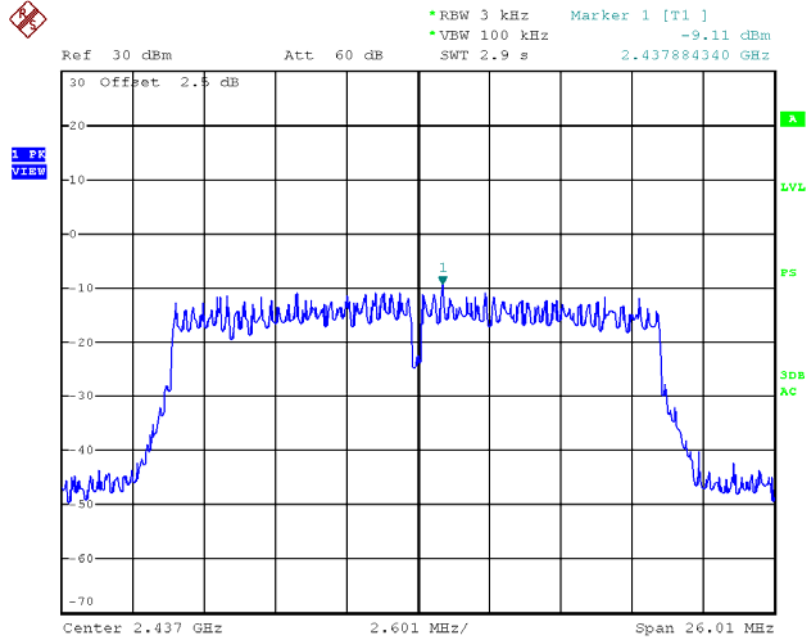

Date: 11.JUL.2014 16:42:29

### Frequency H

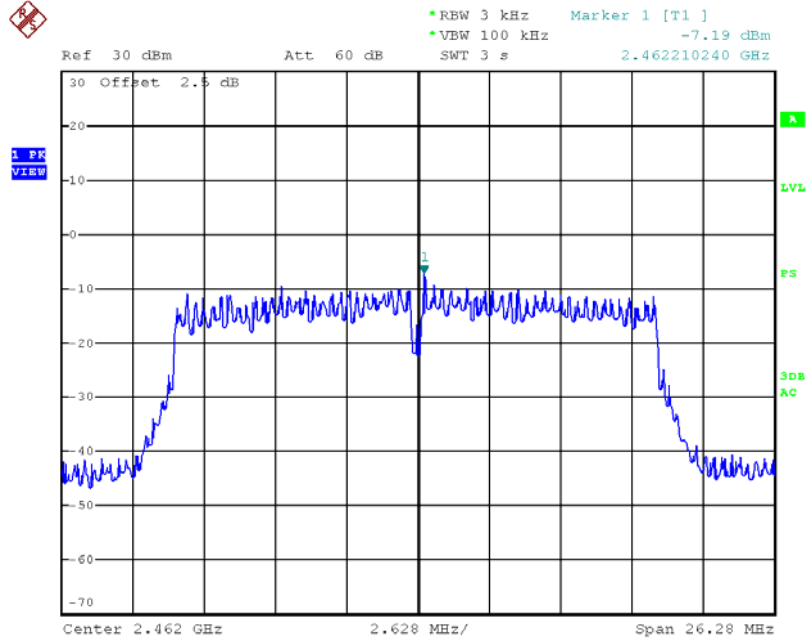

Date: 11.JUL.2014 16:43:40

## 6. Radiated emission

Test result: **PASS**

### 6.1 Test limit

The radiated emissions which fall in the restricted bands, as defined in §15.205(a), must also comply with the radiated emission limits specified in §15.209(a) showed as below:

Frequency (MHz)	Field Strength (dBuV/m)	Measurement Distance (m)
30 - 88	40.0	3
88 - 216	43.5	3
216 - 960	46.0	3
Above 960	54.0	3

### 6.2 Test Configuration

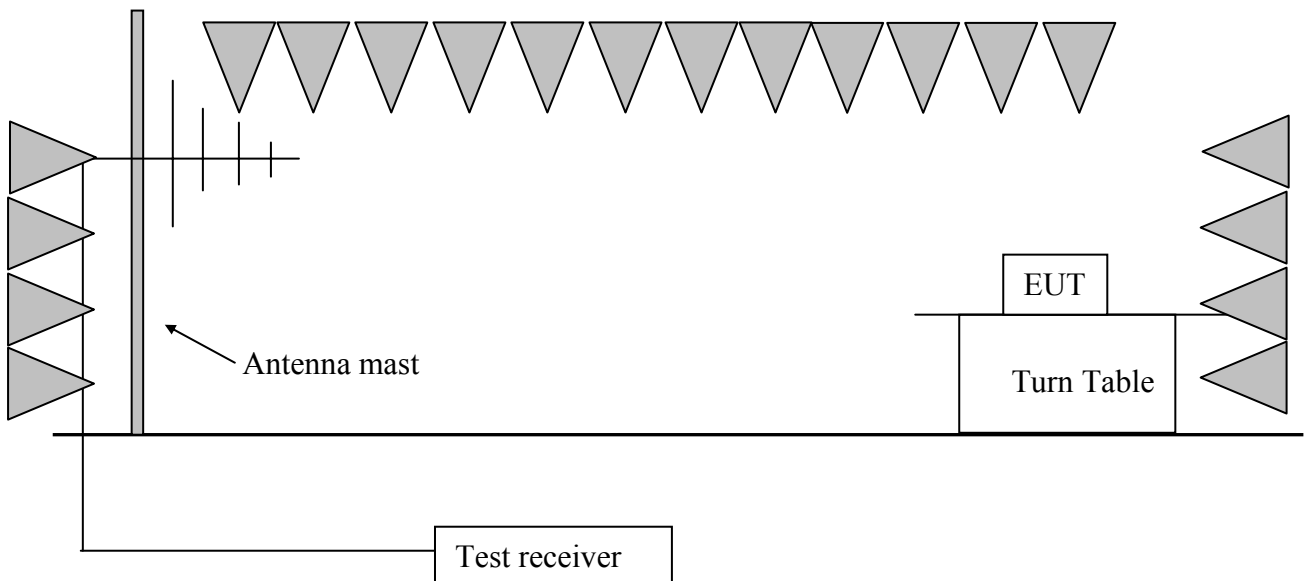



### **6.3 Test procedure and test setup**

The measurement was applied in a semi-anechoic chamber. While testing for spurious emission higher than 1GHz, if applied, the pre-amplifier would be equipped just at the output terminal of the antenna.

The EUT and simulators were placed on a 0.8m high wooden turntable above the horizontal metal ground plane. The turn table rotated 360 degrees to determine the position of the maximum emission level. The EUT was set 3 meters away from the receiving antenna which was mounted on an antenna mast. The antenna moved up and down between from 1meter to 4 meters to find out the maximum emission level.

The EUT was tested according to DTS test procedure of KDB558074 D01 DTS “Meas Guidance v03r02” (clause 12) for compliance to FCC 47CFR 15.247 requirements.

### 6.4 Test protocol

Temperature : 25°C  
Relative Humidity : 55 %

#### Worst Case below 1GHz:

#### Horizontal

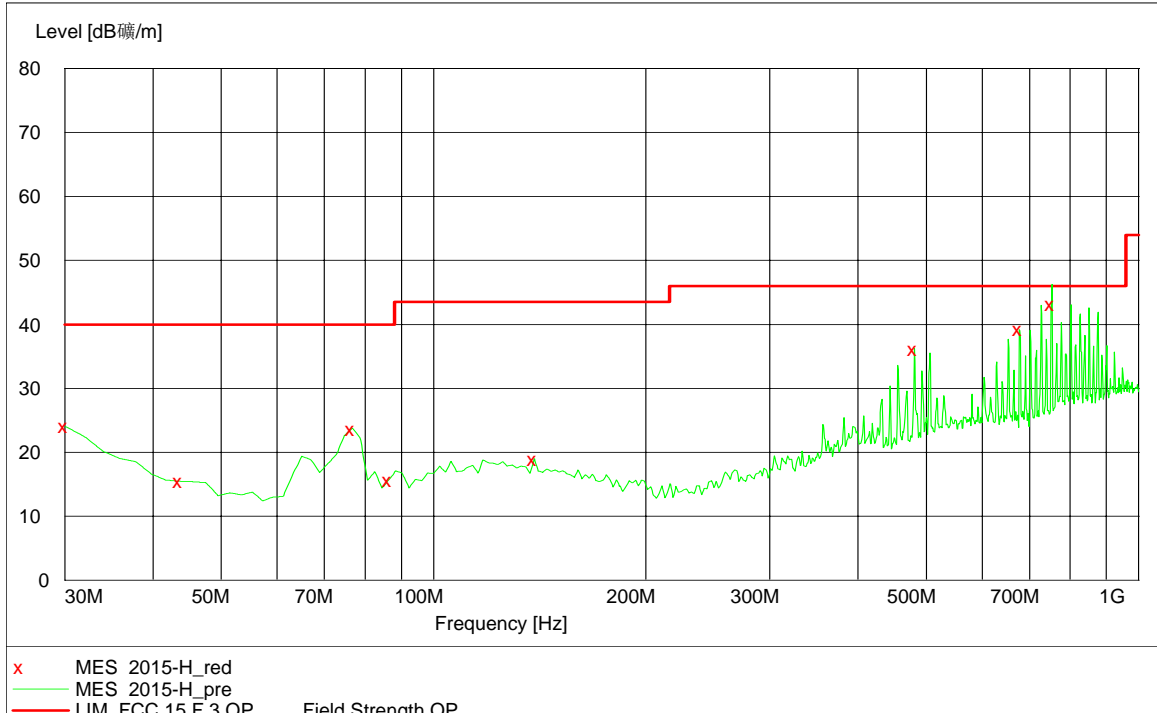

#### Vertical

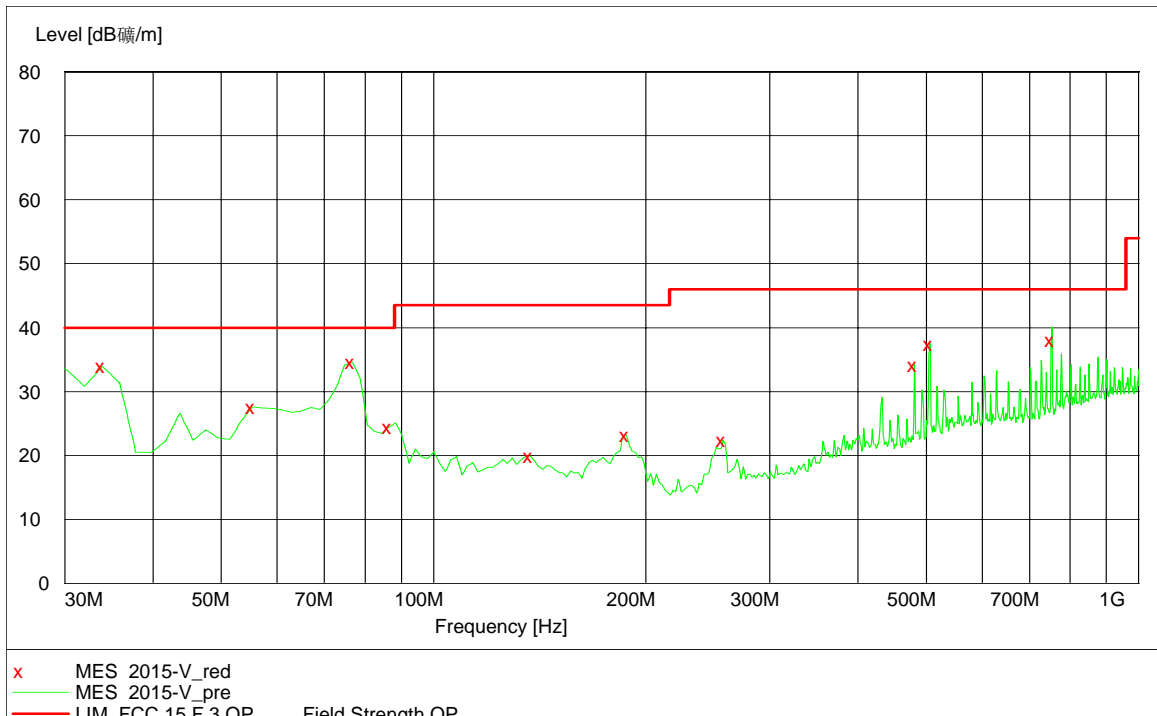

Test data:

Polarization	Frequency (MHz)	Measured level (dB $\mu$ V/m)	Limits (dB $\mu$ V/m)	Margin (dB)	Factor (dB)	Detector
H	30.00	24.00	40.00	16.00	22.00	PK
	43.61	15.50	40.00	24.50	13.70	PK
	76.65	23.70	40.00	16.30	10.00	PK
	86.37	15.70	40.00	24.30	11.30	PK
	138.86	19.00	43.50	24.50	15.20	PK
	480.98	36.20	46.00	9.80	20.00	PK
	677.31	39.20	46.00	6.80	22.60	PK
	753.13	43.20	46.00	2.80	23.10	QP
V	33.89	33.90	40.00	6.10	19.10	PK
	55.27	27.60	40.00	12.40	9.50	PK
	76.65	34.60	40.00	5.40	10.00	PK
	86.37	24.50	40.00	15.50	11.30	PK
	136.91	19.90	43.50	23.60	15.40	PK
	187.45	23.20	43.50	20.30	12.00	PK
	257.43	22.40	46.00	23.60	14.10	PK
	480.98	34.20	46.00	11.80	20.00	PK
	506.25	37.50	46.00	8.50	20.50	PK
	753.13	38.10	46.00	7.90	23.10	PK

- Remark: 1. Factor = Antenna Factor + Cable Loss (-Amplifier, is employed)  
 2. Measure level = Original Receiver Reading Level+ Correct Factor  
 3. Margin = limit - Measure level

Example: Assuming Antenna Factor = 30.20dB/m, Cable Loss = 2.00dB,  
 Gain of Preamplifier = 32.00dB, Original Receiver Reading level = 10dBuV.  
 Then Factor = 30.20 + 2.00 – 32.00 = 0.20dB/m; Measure level = 10dBuV +  
 0.20dB/m = 10.20dBuV/m  
 Assuming limit = 54dBuV/m, Measure level = 10.20dBuV/m, then Margin = 54-  
 10.20 = 43.80dBuV/m

**Above 1GHz:**

1: 802.11b

Polarity	Frequency (MHz)	Measured level (dBuV/m)	Limit (dBuV/m)	Factor (dB)	Antenna (cm)	Turn table (deg)	Margin (dB)	Remark
Ver/Hor	2390	62.32	74	-7.80	100	210	11.68	PK
		46.79	54	-7.80	100	210	7.21	AV
	2412	107.30	-	-7.80	100	190	-	PK
		106.20	-	-7.80	100	190	-	AV
	4824	45.34	74	-2.10	100	190	28.66	PK
		37.75	54	-2.10	100	190	16.25	AV
Note:	2412MHz is fundamental signal.							

Polarity	Frequency (MHz)	Measured level (dBuV/m)	Limit (dBuV/m)	Factor (dB)	Antenna (cm)	Turn table (deg)	Margin (dB)	Remark
Ver/Hor	2437	107.31	-	-7.8	100	210	-	PK
		106.12	-	-7.8	100	210	-	AV
	4874	45.42	74	-2.1	100	210	28.58	PK
		36.46	54	-2.1	100	210	17.54	AV
	7311	46.96	74	6.5	100	210	27.04	PK
		37.12	54	6.5	100	210	16.88	AV
Note:	2437MHz is fundamental signal.							

Polarity	Frequency (MHz)	Measured level (dBuV/m)	Limit (dBuV/m)	Factor (dB)	Antenna (cm)	Turn table (deg)	Margin (dB)	Remark
Ver/Hor	2462	106.56	-	-7.8	100	210	-	PK
		105.76	-	-7.8	100	210	-	AV
	2483.5	62.42	74	-7.5	100	210	11.58	PK
		46.42	54	-7.5	100	210	7.58	AV
	4924	43.52	74	-2.1	100	210	30.48	PK
		33.36	54	-2.1	100	210	20.64	AV
	7386	46.42	74	6.5	100	210	27.58	PK
		35.23	54	6.5	100	210	18.77	AV
Note:	2462MHz is fundamental signal.							

2: 802.11g

Polarity	Frequency (MHz)	Measured level (dBuV/m)	Limit (dBuV/m)	Factor (dB)	Antenna (cm)	Turn table (deg)	Margin (dB)	Remark
Ver/Hor	2390	66.55	74	-7.8	100	190	7.45	PK
		50.48	54	-7.8	100	190	3.52	AV
	2412	103.45	-	-7.8	100	190	-	PK
		102.56	-	-7.8	100	190	-	AV
	4824	43.27	74	-2.1	100	190	30.73	PK
		34.65	54	-2.1	100	190	19.35	AV
Note:	2412MHz is fundamental signal.							

Polarity	Frequency (MHz)	Measured level (dBuV/m)	Limit (dBuV/m)	Factor (dB)	Antenna (cm)	Turn table (deg)	Margin (dB)	Remark
Ver/Hor	2437	103.34	-	-7.8	100	213	-	PK
		102.56	-	-7.8	100	213	-	AV
	4874	46.34	74	-2.1	100	213	27.66	PK
		33.88	54	-2.1	100	213	20.12	AV
	7311	48.63	74	6.5	100	213	25.37	PK
		37.45	54	6.5	100	213	16.55	AV
Note:	2437MHz is fundamental signal.							

Polarity	Frequency (MHz)	Measured level (dBuV/m)	Limit (dBuV/m)	Factor (dB)	Antenna (cm)	Turn table (deg)	Margin (dB)	Remark
Ver/Hor	2462	103.56	-	-7.8	100	190	-	PK
		103.76	-	-7.8	100	190	-	AV
	2483.5	69.15	74	-7.5	100	190	4.85	PK
		48.53	54	-7.5	100	190	5.47	AV
	4924	43.32	74	-2.1	100	190	30.68	PK
		34.53	54	-2.1	100	190	19.47	AV
	7386	43.44	74	6.5	100	190	30.56	PK
		35.22	54	6.5	100	190	18.78	AV
Note:	2462MHz is fundamental signal.							

3: 802.11n20

Polarity	Frequency (MHz)	Measured level (dBuv/m)	Limit (dBuv/m)	Factor (dB)	Antenna (cm)	Turn table (deg)	Margin (dB)	Remark
Ver/Hor	2390	65.43	74	-7.8	100	190	8.57	PK
		50.66	54	-7.8	100	190	3.34	AV
	2412	102.45	-	-7.8	100	190	-	PK
		101.36	-	-7.8	100	190	-	AV
	4824	43.72	74	-2.1	100	190	30.28	PK
		34.45	54	-2.1	100	190	19.55	AV
Note:	2412MHz is fundamental signal.							

Polarity	Frequency (MHz)	Measured level (dBuv/m)	Limit (dBuv/m)	Factor (dB)	Antenna (cm)	Turn table (deg)	Margin (dB)	Remark
Ver/Hor	2437	101.21	-	-7.8	100	223	-	PK
		102.44	-	-7.8	100	223	-	AV
	4874	43.47	74	-2.1	100	223	30.53	PK
		35.44	54	-2.1	100	223	18.56	AV
	7311	48.49	74	6.5	100	223	25.51	PK
		38.55	54	6.5	100	223	15.45	AV
Note:	2437MHz is fundamental signal.							

Polarity	Frequency (MHz)	Measured level (dBuv/m)	Limit (dBuv/m)	Factor (dB)	Antenna (cm)	Turn table (deg)	Margin (dB)	Remark
Ver/Hor	2462	101.84	-	-7.8	100	179	-	PK
		100.44	-	-7.8	100	179	-	AV
	2483.5	65.22	74	-7.5	100	179	8.78	PK
		45.78	54	-7.5	100	179	8.22	AV
	4924	44.66	74	-2.1	100	179	29.34	PK
		34.52	54	-2.1	100	179	19.48	AV
	7386	45.66	74	6.5	100	179	28.34	PK
		36.56	54	6.5	100	179	17.44	AV
Note:	2462MHz is fundamental signal.							

## 7. Emission outside the frequency Band

Test result: PASS

### 7.1 Limit

In any 100 kHz bandwidth outside the frequency band in which the spread spectrum intentional radiator is operating, the radio frequency power that is produced by the intentional radiator shall be at least 20 dB below that in the 100 kHz bandwidth within the band that contains the highest level of the desired power.

### 7.2 Test Configuration

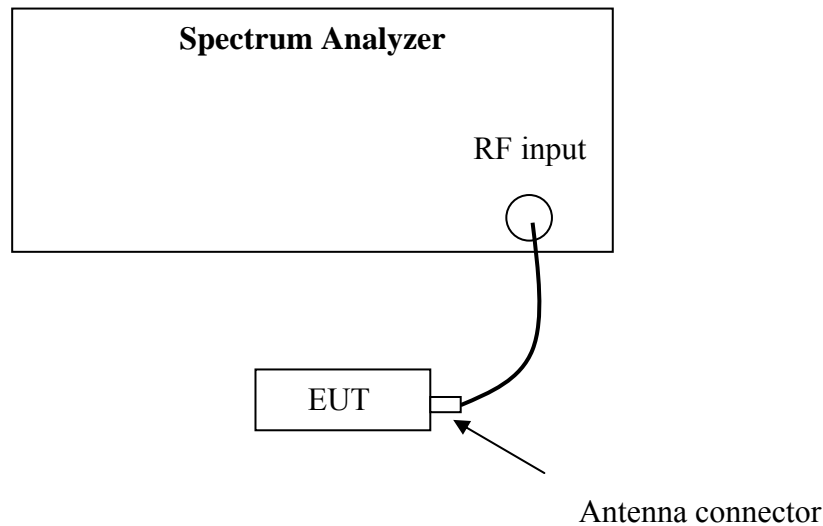

### 7.3 Test procedure and test setup

The Emission outside the frequency Band per FCC § 15.247(d) is measured using the Spectrum Analyzer with the resolutions bandwidth set at 100kHz, the video bandwidth set at 300kHz, and the SPAN>>RBW.

The EUT was tested according to DTS test procedure of “KDB558074 D01 DTS Meas Guidance v03r02” (clause 11.0) for compliance to FCC 47CFR 15.247 requirements.

### 7.4 Test protocol

Temperature : 25°C  
Relative Humidity : 55 %

### 802.11b Out-of-Band Emissions:

Reference Level – Frequency L

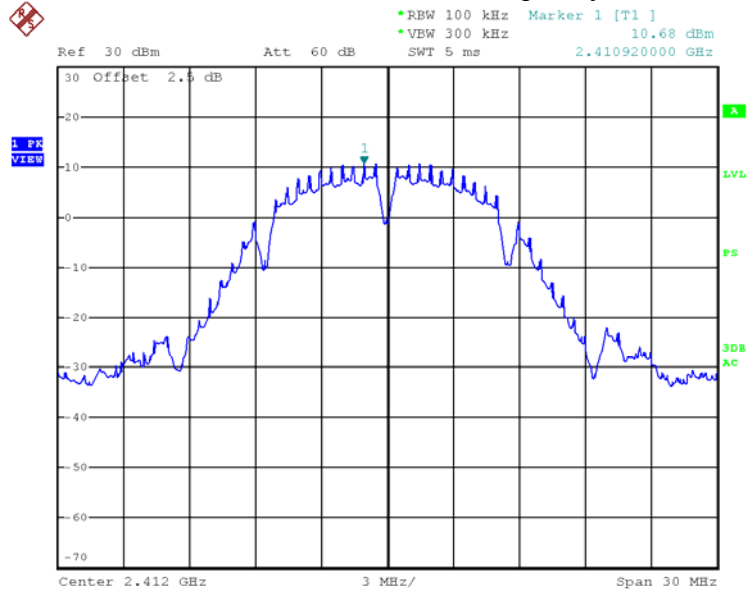

Date: 11.JUL.2014 16:54:30

Low Band Edge - Frequency L

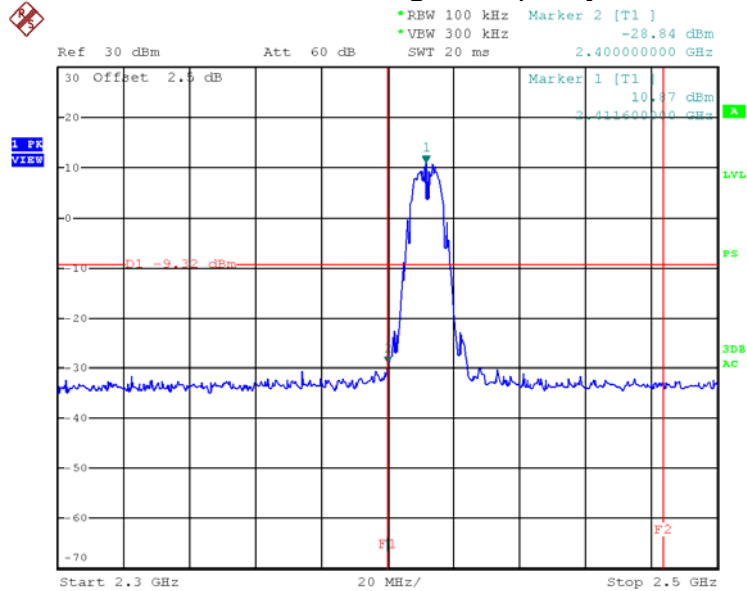

Date: 11.JUL.2014 17:20:40



### Spurious Emission 1MHz ~ 2.3GHz - Frequency L

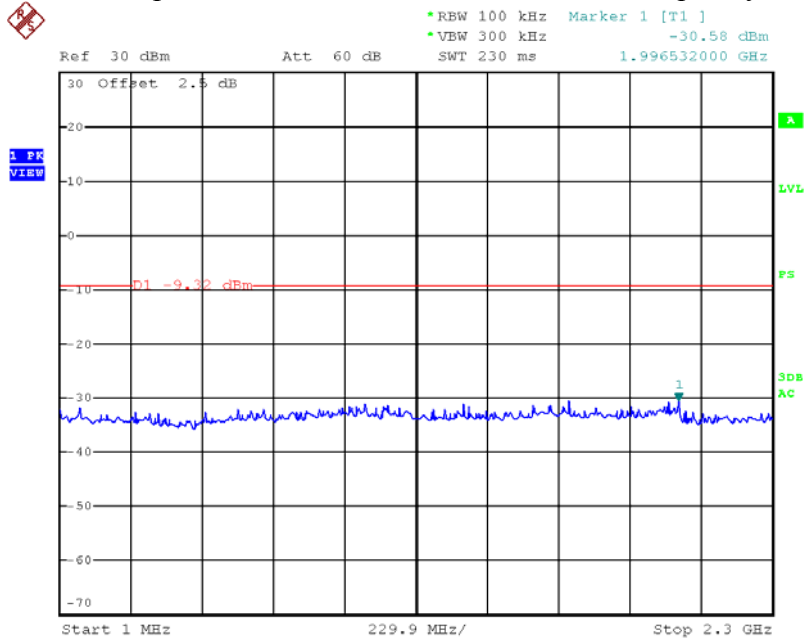

Date: 11.JUL.2014 17:18:23

### Spurious Emission 2.5GHz ~ 7GHz - Frequency L

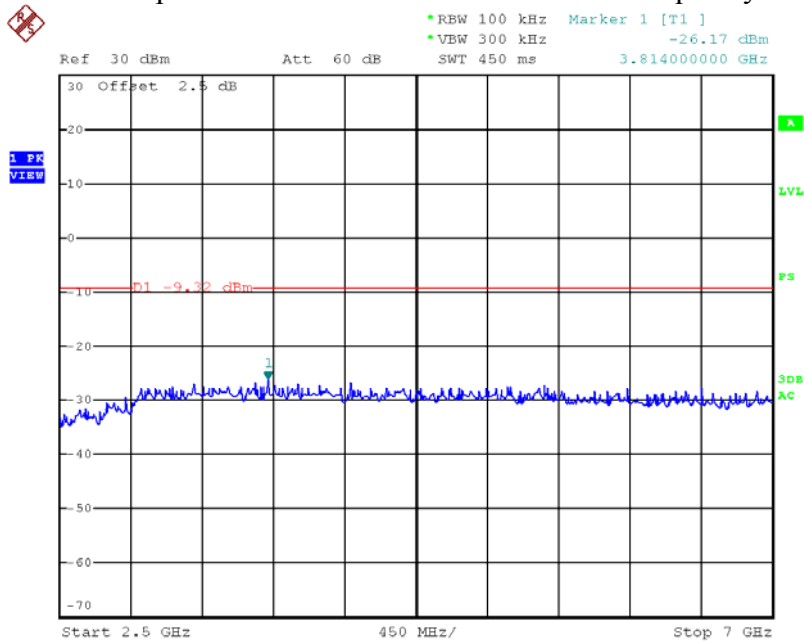

Date: 11.JUL.2014 17:22:06

### Spurious Emission 7GHz ~ 25GHz - Frequency L

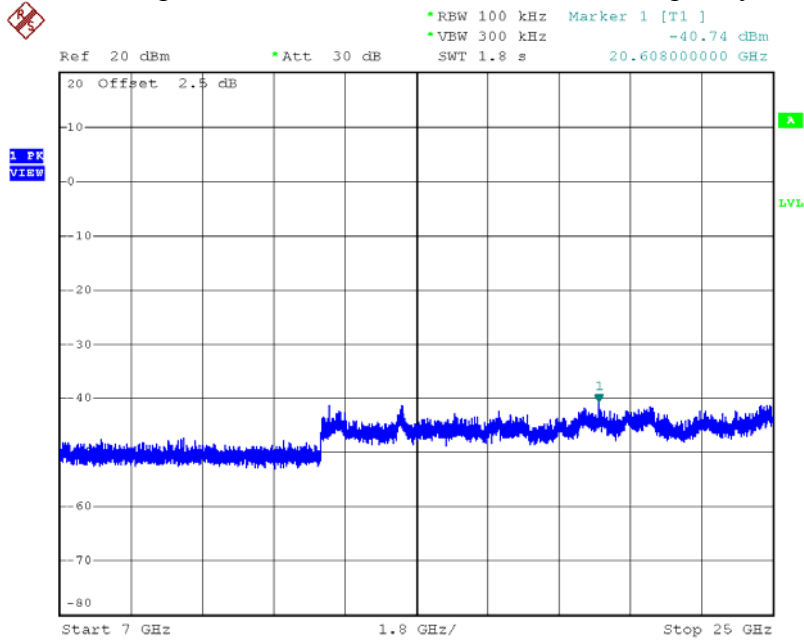

### Reference Level – Frequency M

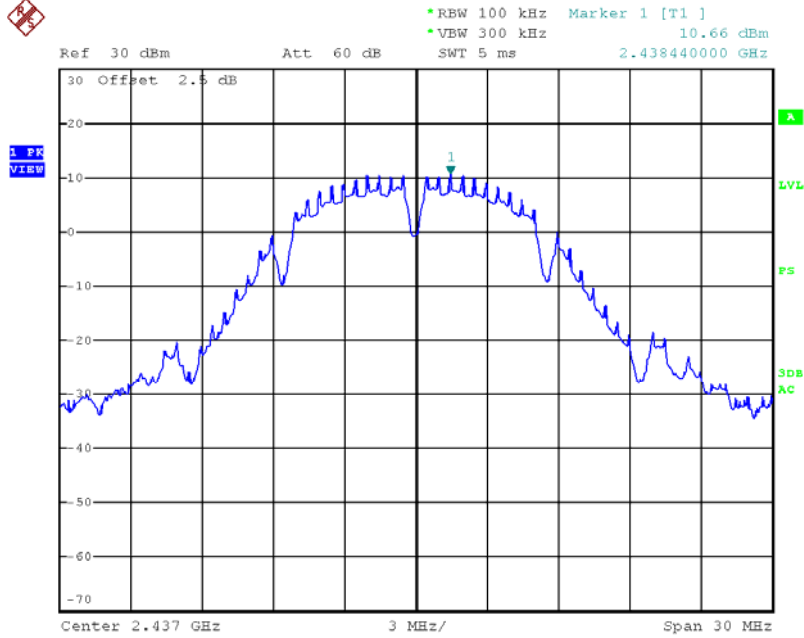

Date: 11.JUL.2014 16:56:06

### Band Edge - Frequency M

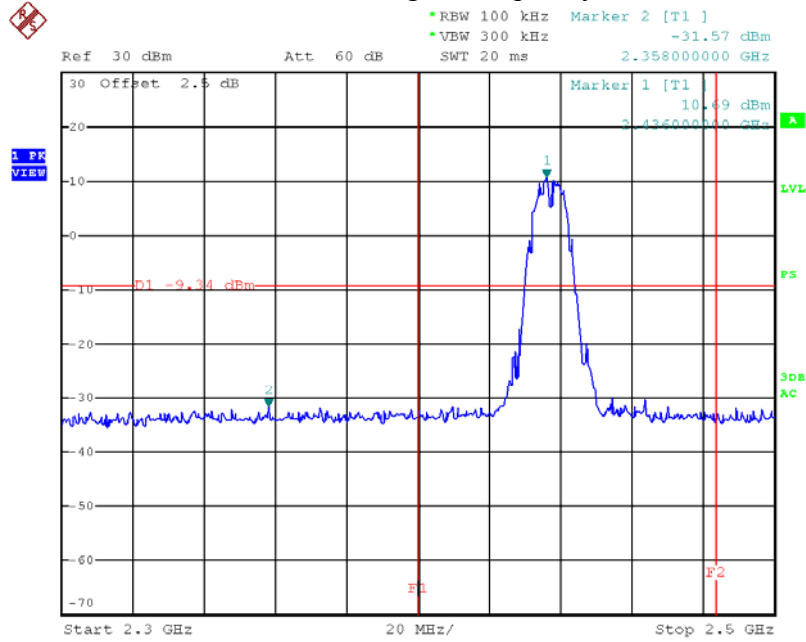

Date: 11.JUL.2014 17:25:42

### Spurious Emission 1MHz ~ 2.3GHz - Frequency M

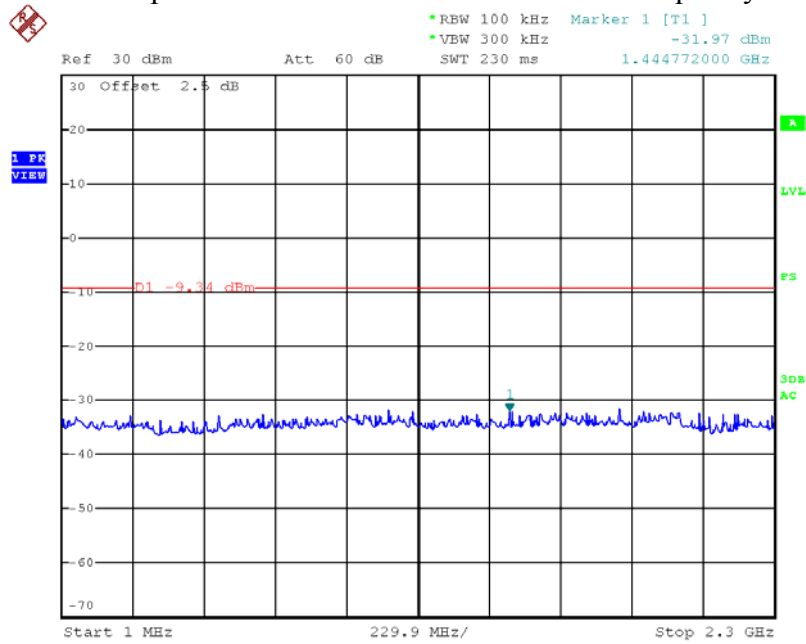

Date: 11.JUL.2014 17:23:33

**Spurious Emission 2.5GHz ~ 7GHz - Frequency M**

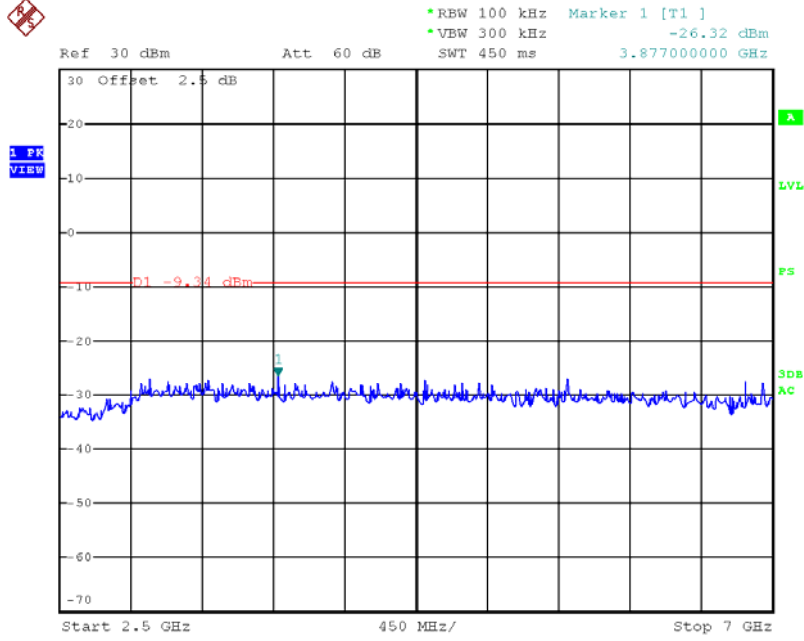

Date: 11.JUL.2014 17:26:37

**Spurious Emission 7GHz ~ 25GHz - Frequency M**

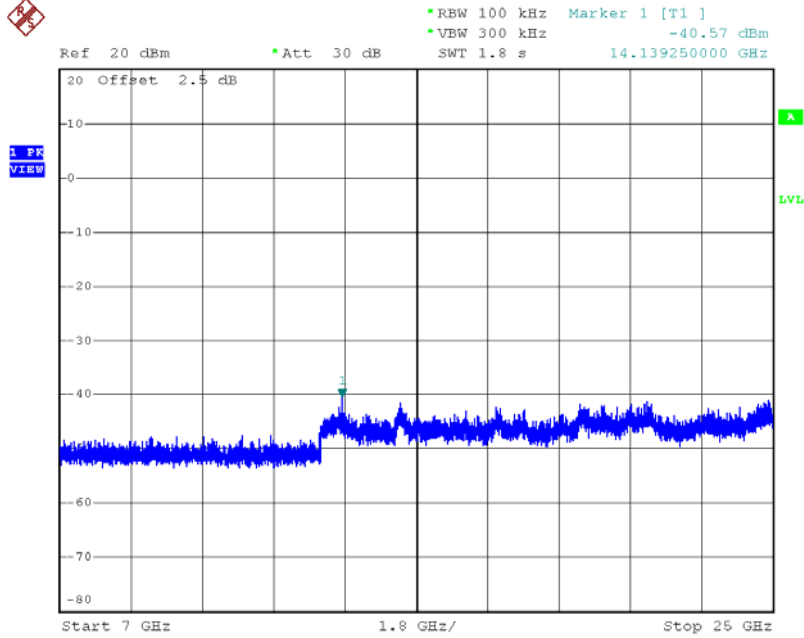

### Reference Level – Frequency H

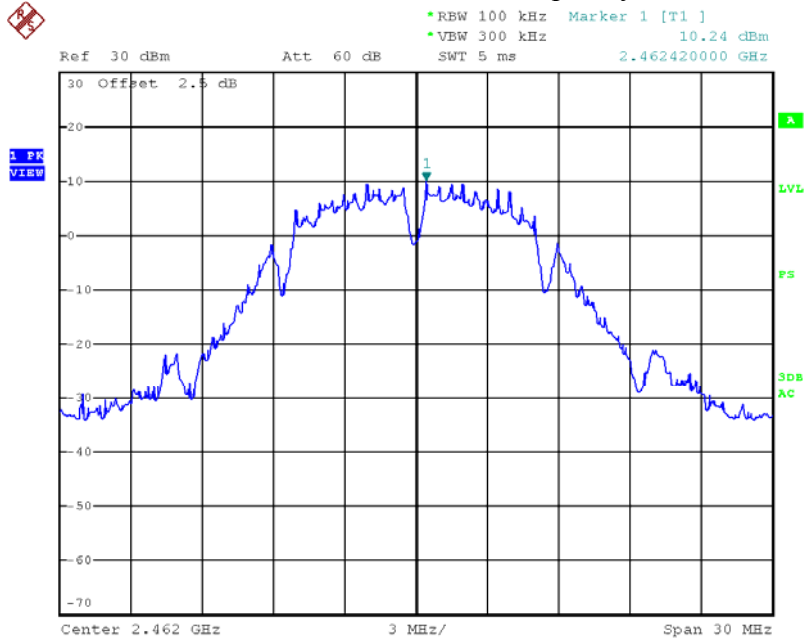

Date: 11.JUL.2014 16:57:42

### High Band Edge - Frequency H

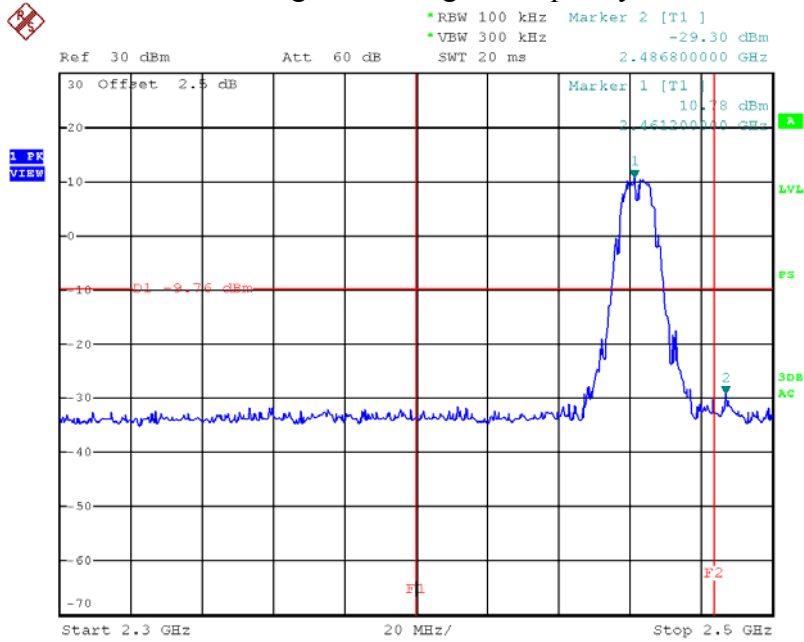

Date: 11.JUL.2014 17:29:46

### Spurious Emission 1MHz ~ 2.3GHz - Frequency H

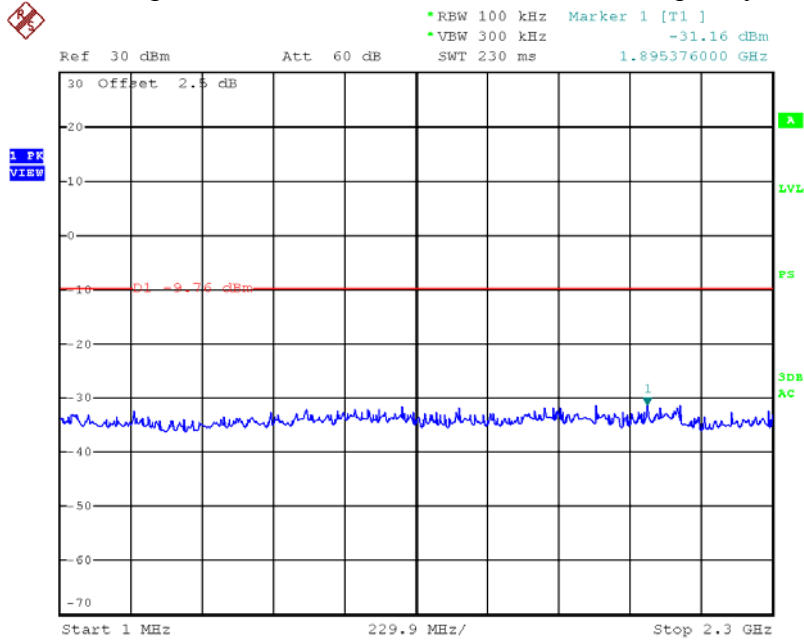

Date: 11.JUL.2014 17:27:40

### Spurious Emission 2.5GHz ~ 7GHz - Frequency H

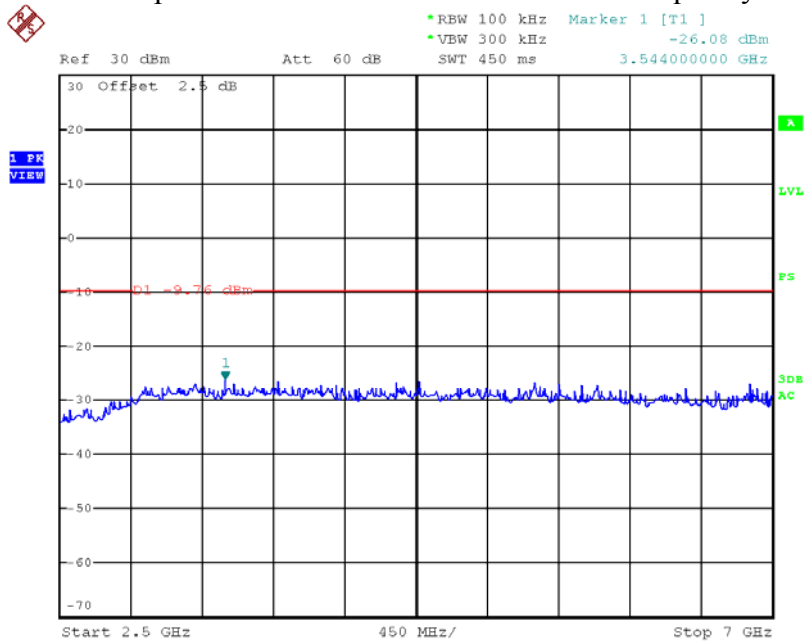

Date: 11.JUL.2014 17:30:43

**Spurious Emission 7GHz ~ 25GHz - Frequency H**

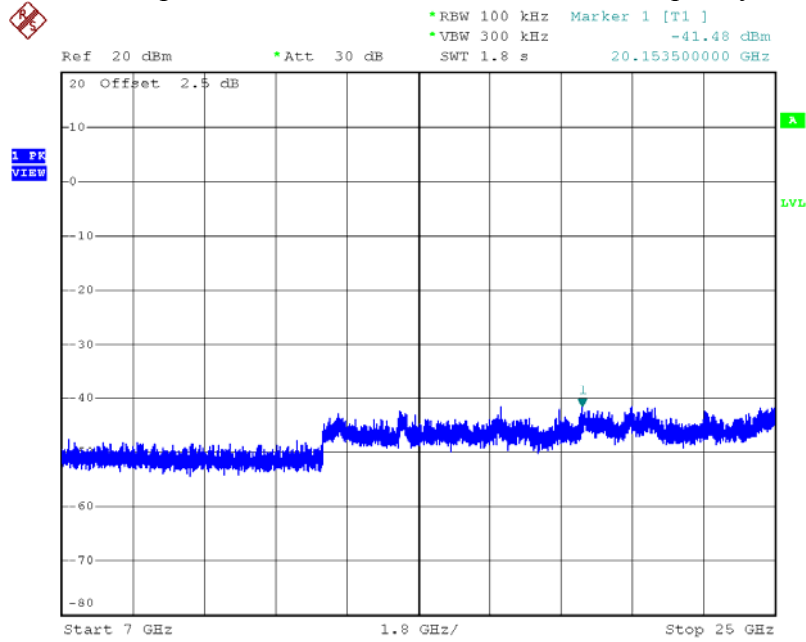

**802.11g Out-of-Band Emissions:**

**Reference Level – Frequency L**

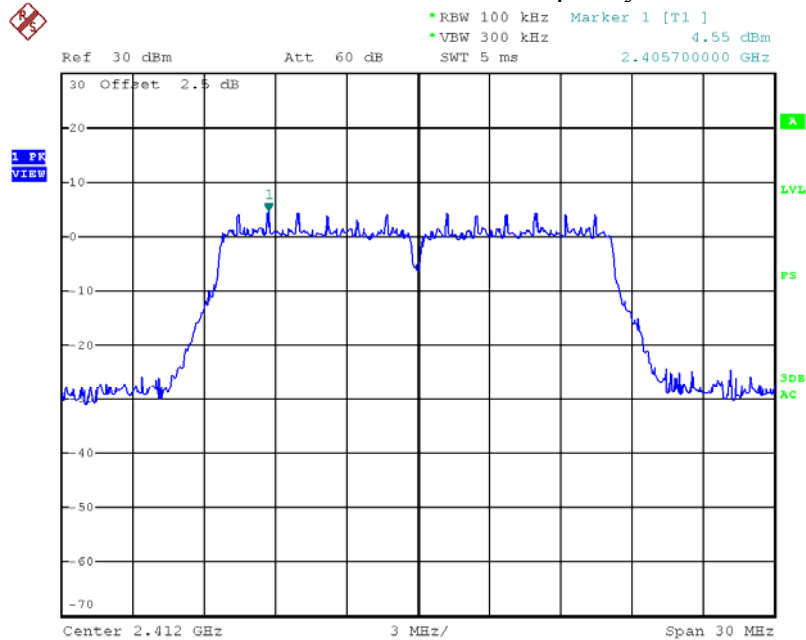

Date: 11.JUL.2014 16:58:55

**Low Band Edge - Frequency L**

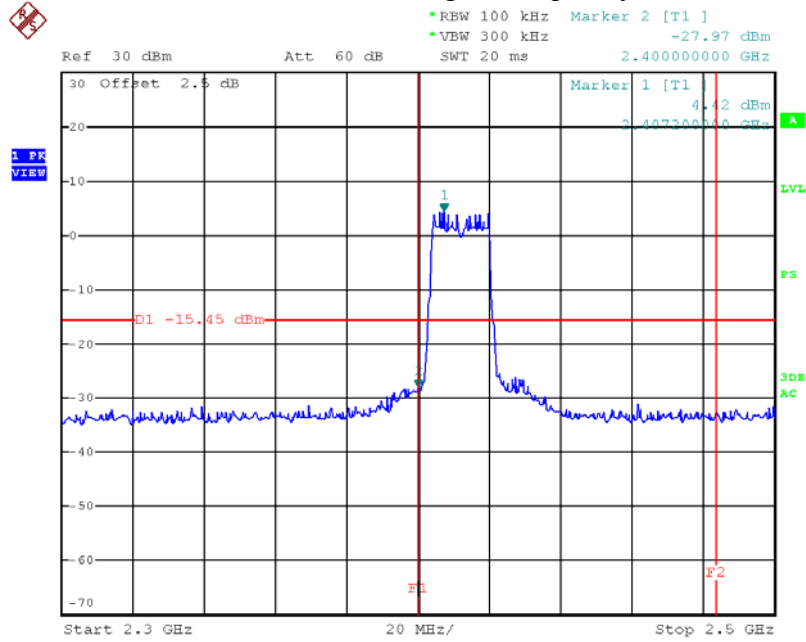

Date: 11.JUL.2014 17:38:53

**Spurious Emission 1MHz ~ 2.3GHz - Frequency L**

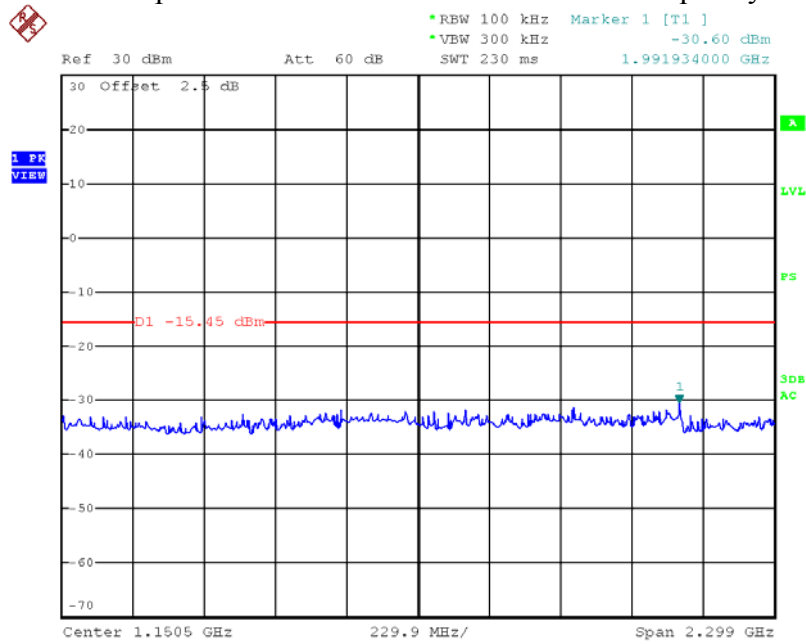

Date: 11.JUL.2014 17:37:03



### Spurious Emission 2.5GHz ~ 7GHz - Frequency L

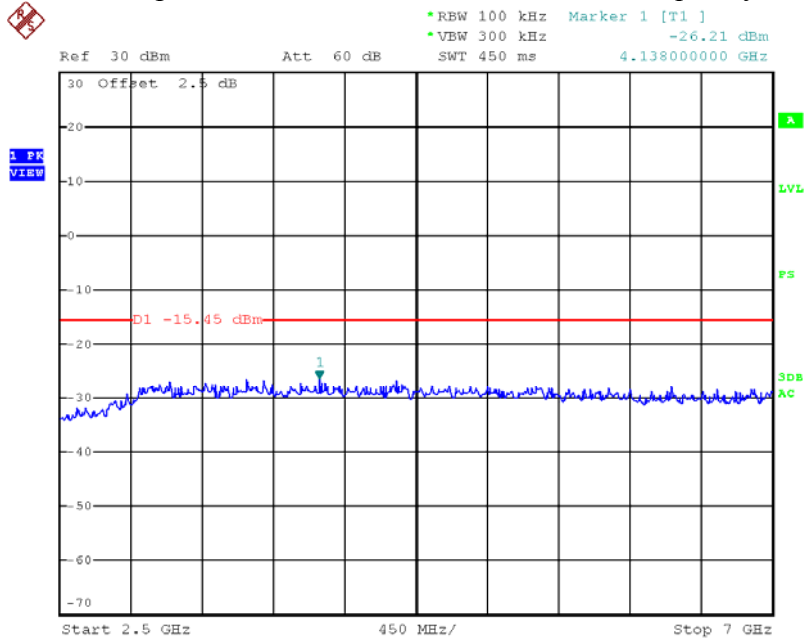

Date: 11.JUL.2014 17:39:54

### Spurious Emission 7GHz ~ 25GHz - Frequency L

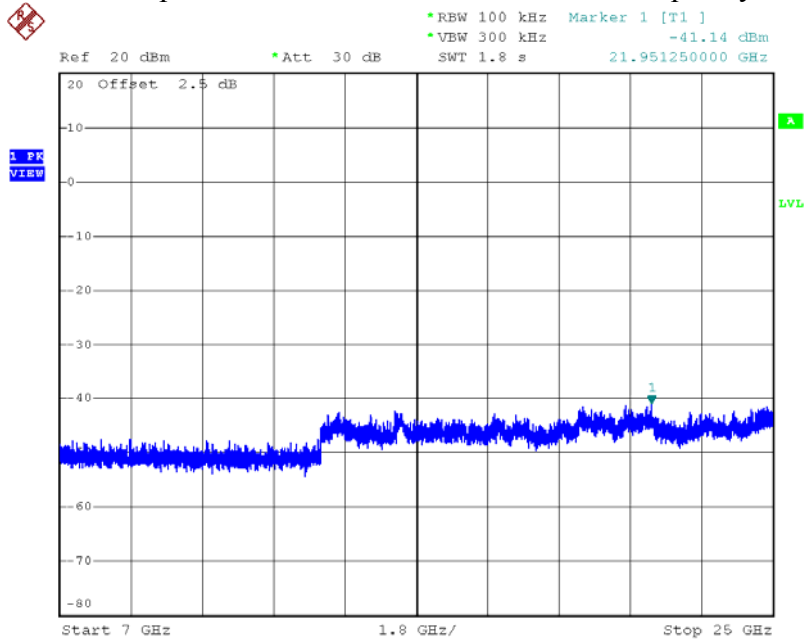

### Reference Level – Frequency M

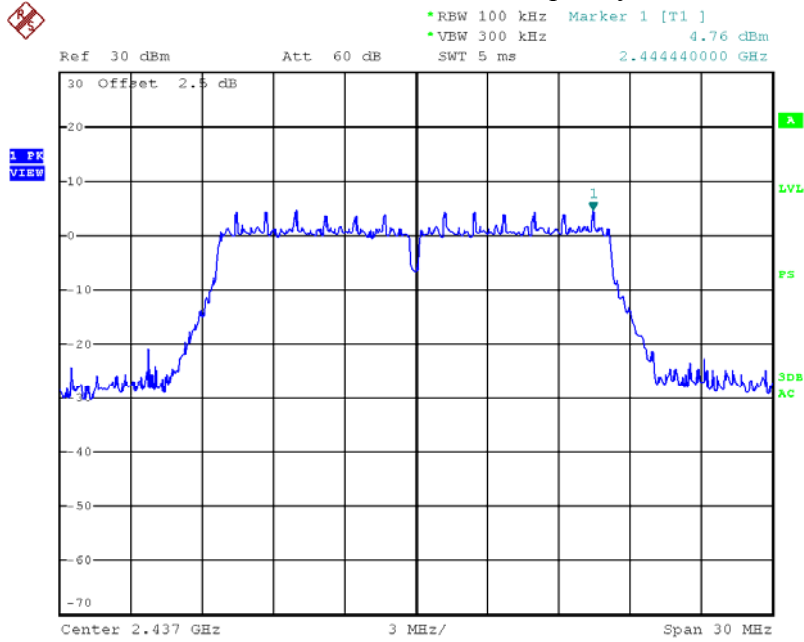

Date: 11.JUL.2014 17:00:13

### Band Edge - Frequency M

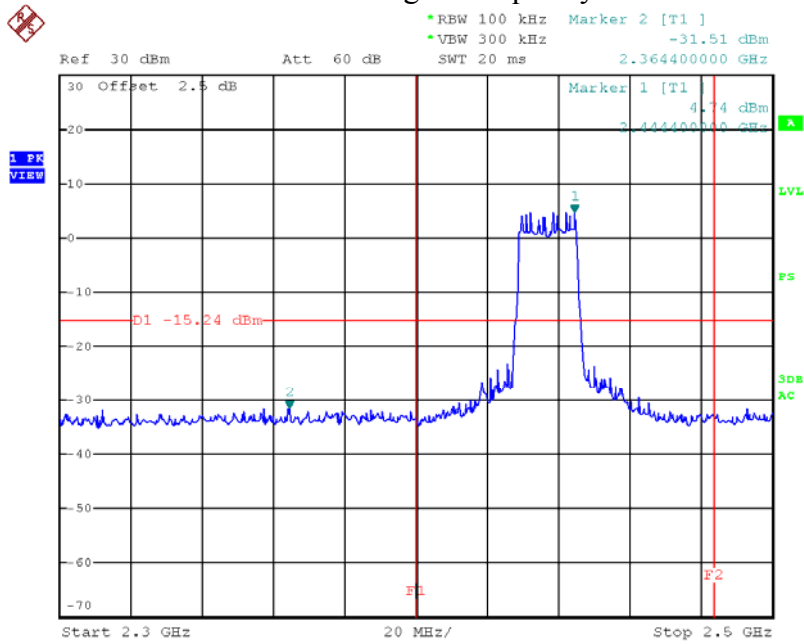

Date: 11.JUL.2014 17:42:34

### Spurious Emission 1MHz ~ 2.3GHz - Frequency M

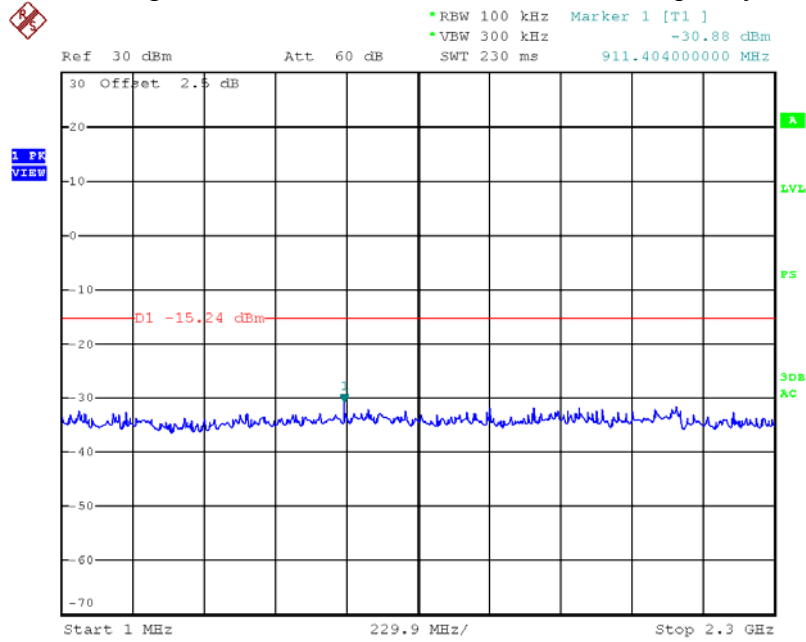

Date: 11.JUL.2014 17:41:17

### Spurious Emission 2.5GHz ~ 7GHz - Frequency M

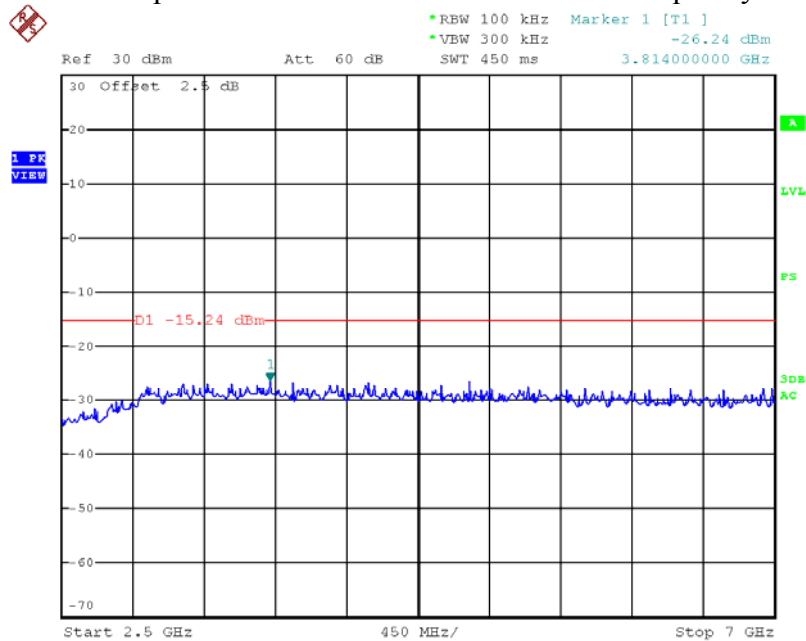

Date: 11.JUL.2014 17:43:54

**Spurious Emission 7GHz ~ 25GHz - Frequency M**

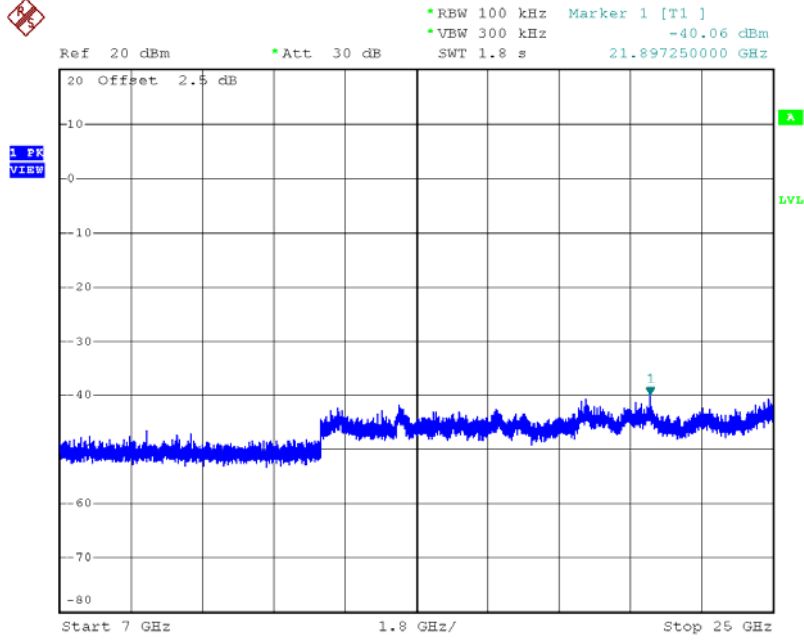

**Reference Level – Frequency H**

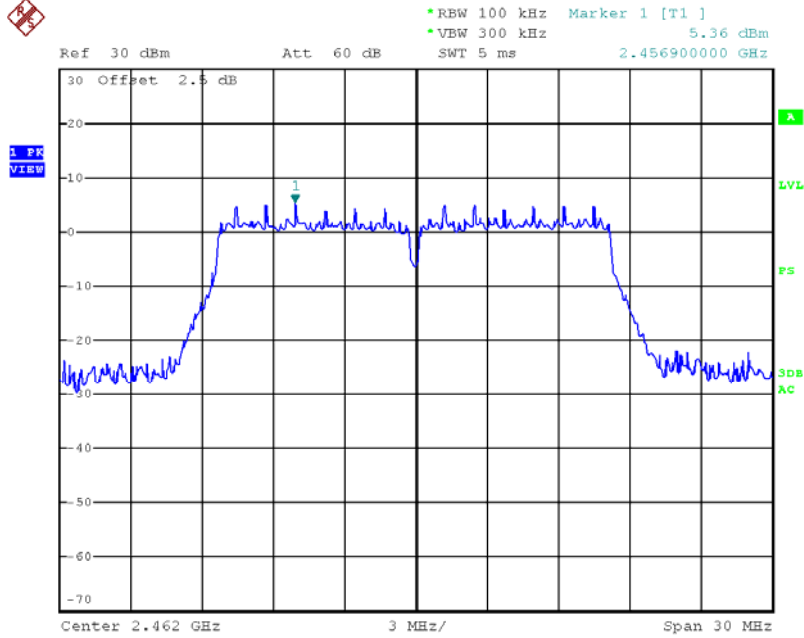

Date: 11.JUL.2014 17:01:24

### High Band Edge - Frequency H

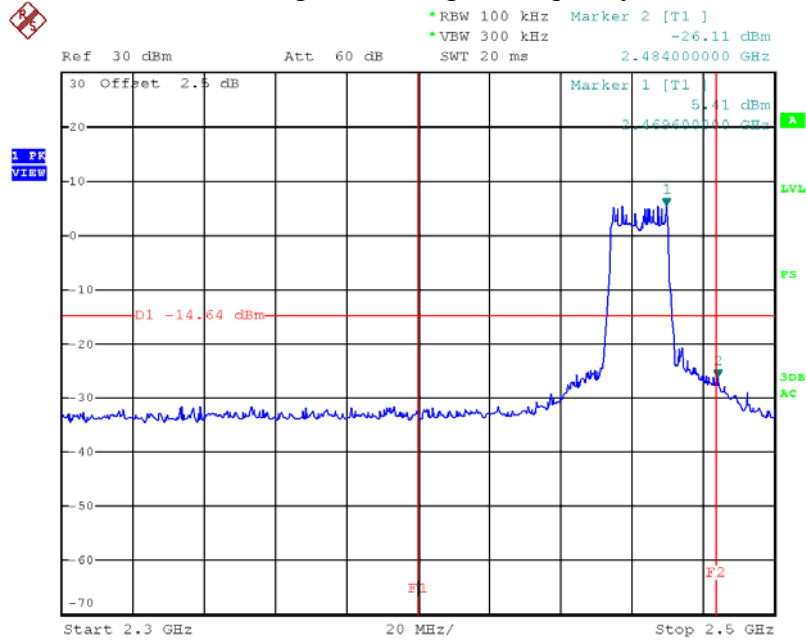

Date: 11.JUL.2014 17:46:52

### Spurious Emission 1MHz ~ 2.3GHz - Frequency H

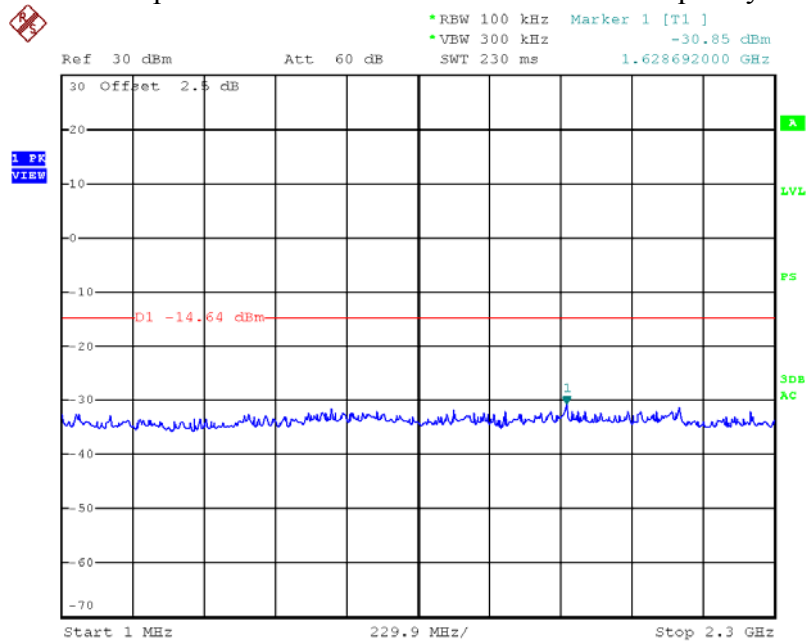

Date: 11.JUL.2014 17:45:18

**Spurious Emission 2.5GHz ~ 7GHz - Frequency H**

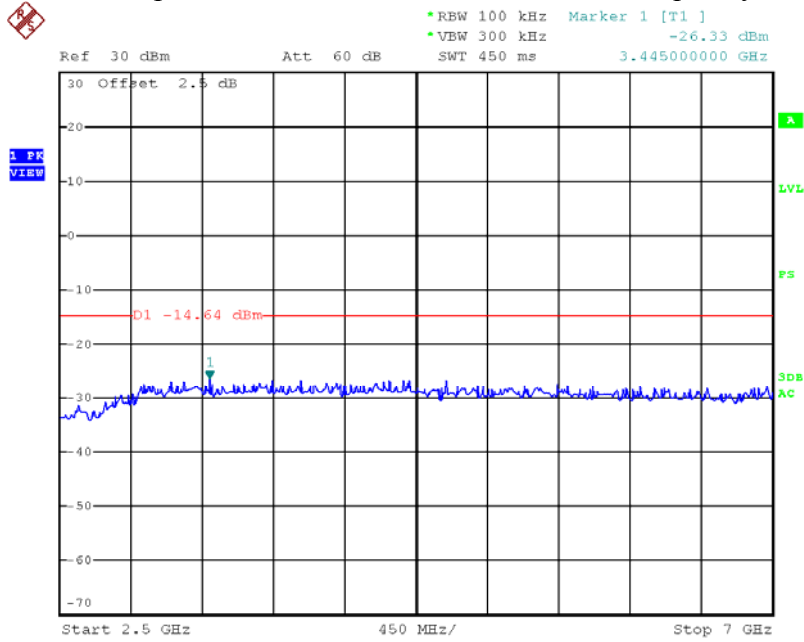

Date: 11.JUL.2014 17:47:53

**Spurious Emission 7GHz ~ 25GHz - Frequency H**

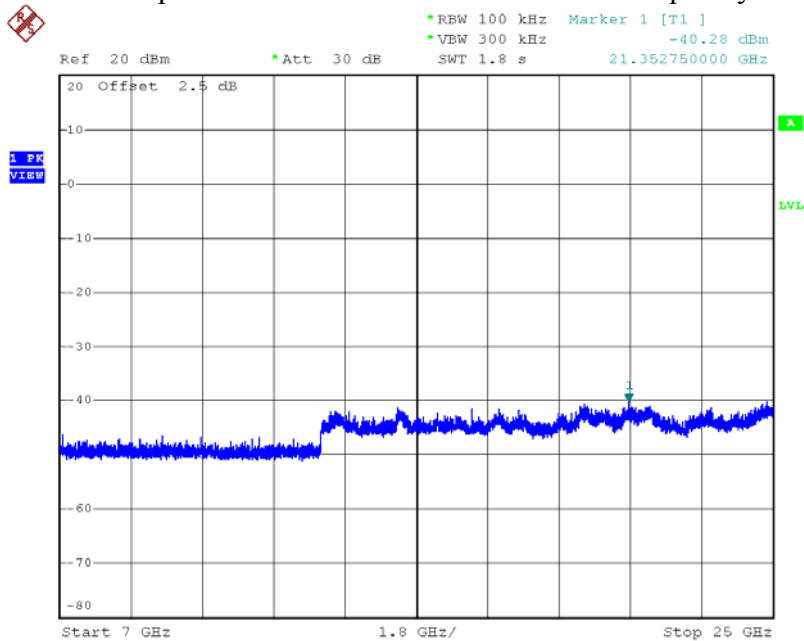

### 802.11n20 Out-of-Band Emissions:

#### Reference Level – Frequency L

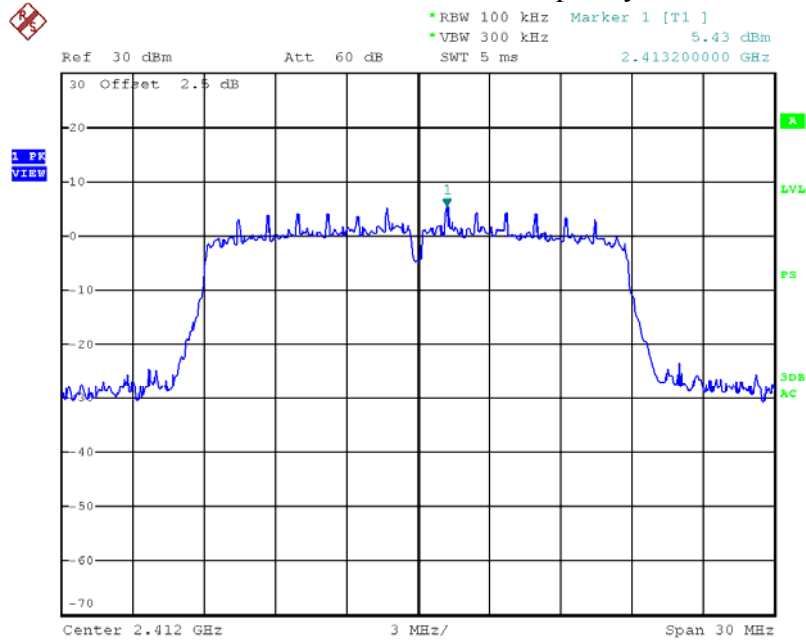

Date: 11.JUL.2014 17:02:44

#### Low Band Edge - Frequency L

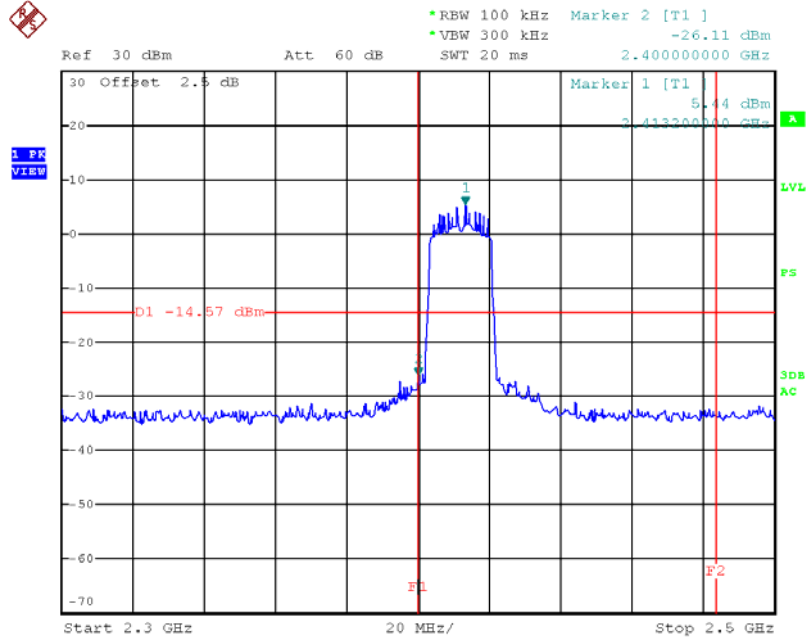

Date: 11.JUL.2014 17:50:28

**Spurious Emission 1MHz ~ 2.3GHz - Frequency L**

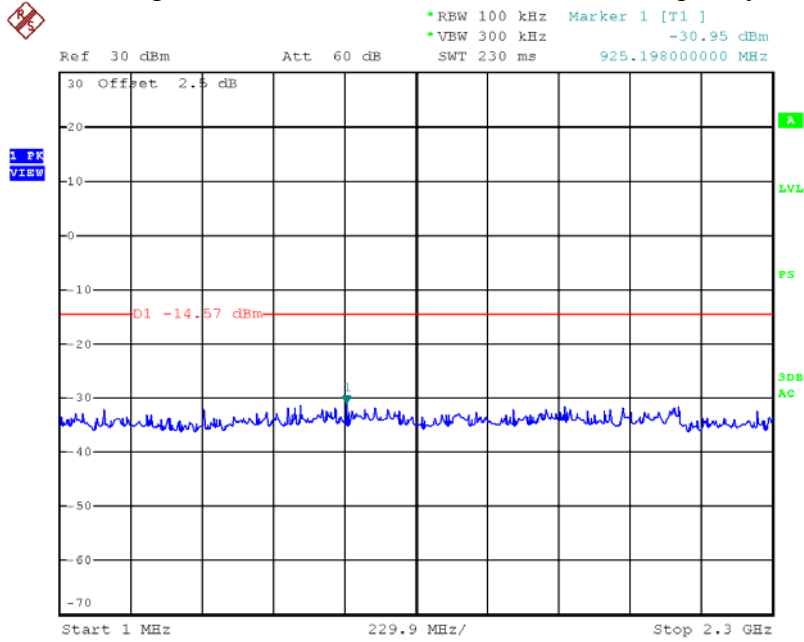

Date: 11.JUL.2014 17:49:22

**Spurious Emission 2.5GHz ~ 7GHz - Frequency L**

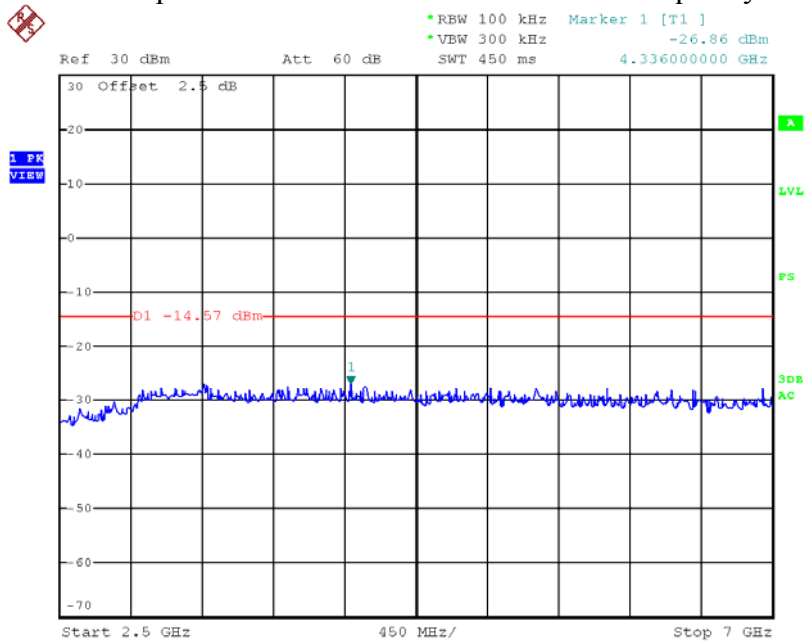

Date: 11.JUL.2014 17:51:18



### Spurious Emission 7GHz ~ 25GHz - Frequency L

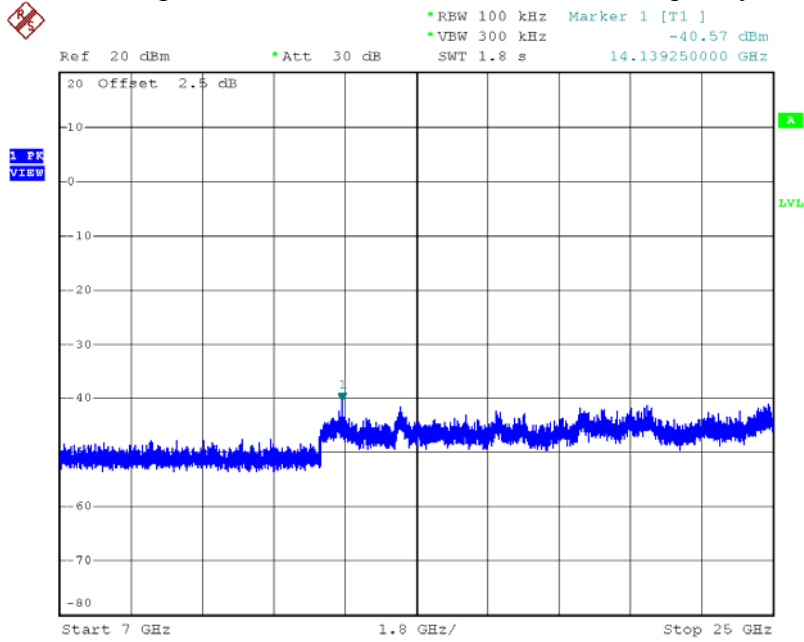

### Reference Level – Frequency M

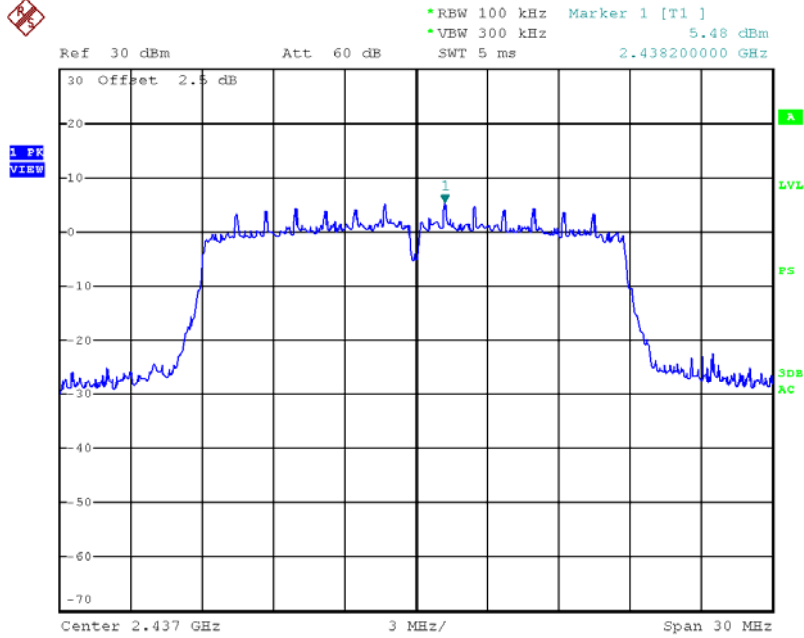

Date: 11.JUL.2014 17:04:03

**Band Edge - Frequency M**

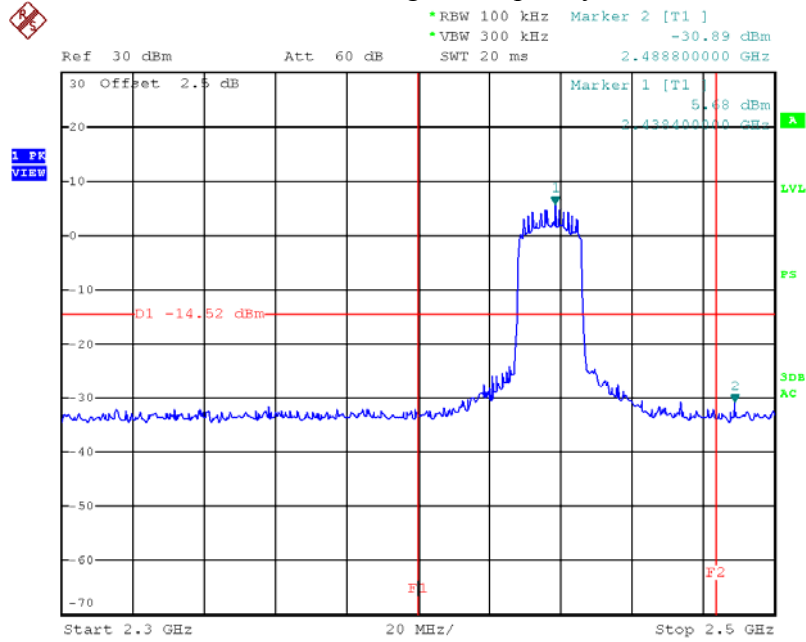

Date: 11.JUL.2014 17:53:46

**Spurious Emission 1MHz ~ 2.3GHz - Frequency M**

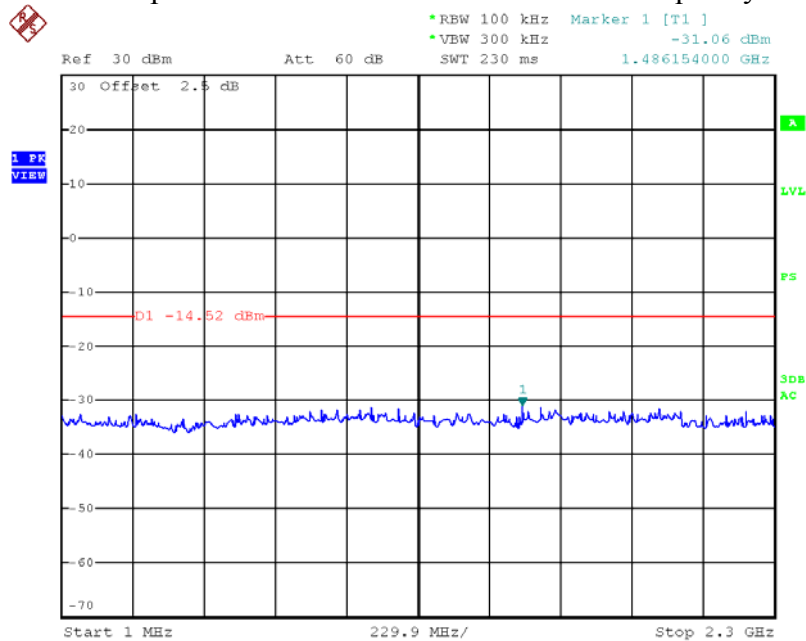

Date: 11.JUL.2014 17:52:16

### Spurious Emission 2.5GHz ~ 7GHz - Frequency M

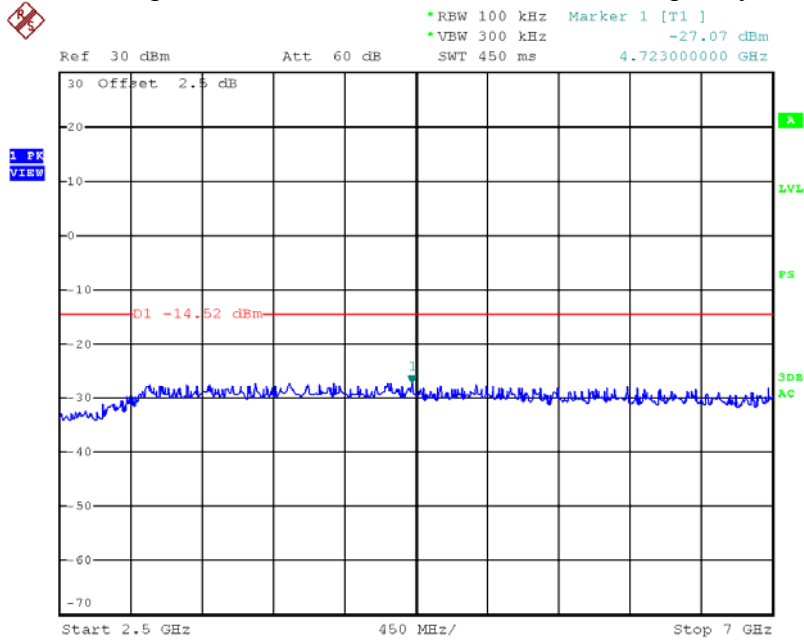

Date: 11.JUL.2014 17:54:38

### Spurious Emission 7GHz ~ 25GHz - Frequency M

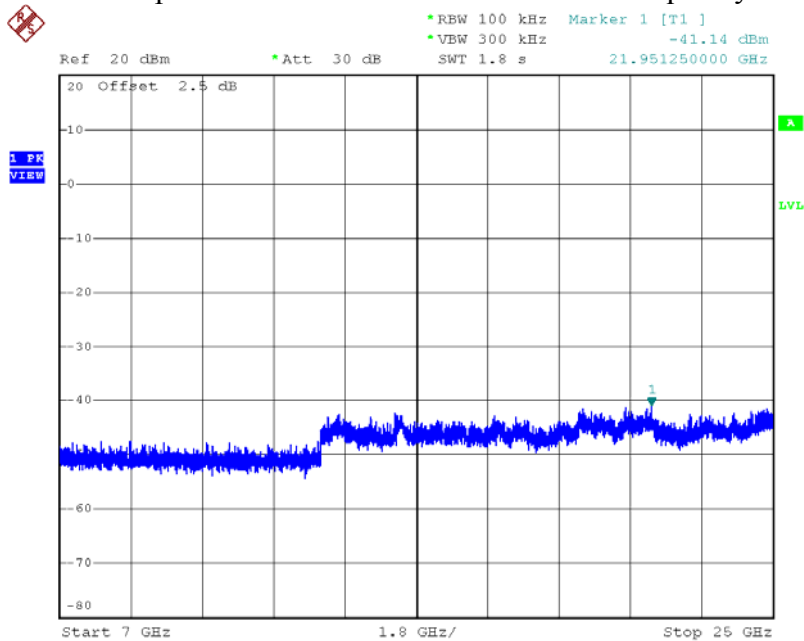

**Reference Level – Frequency H**

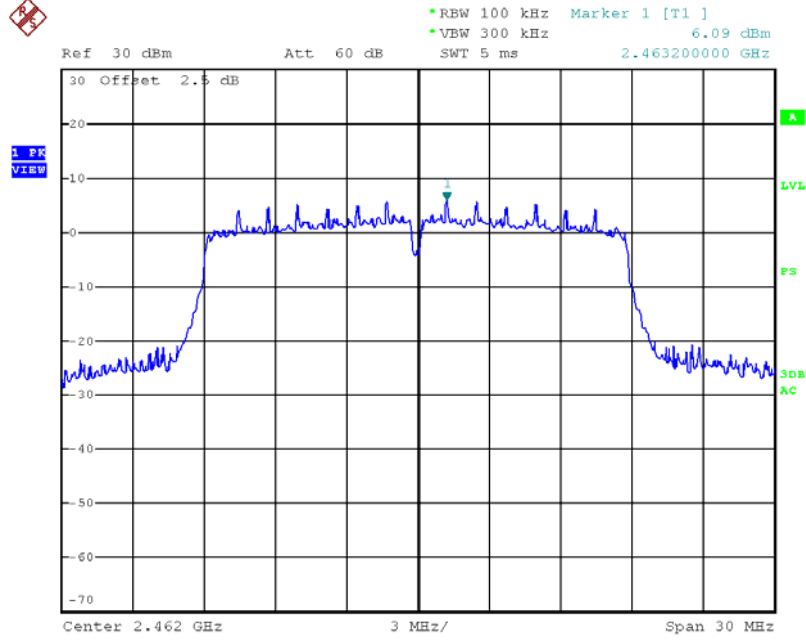

Date: 11.JUL.2014 17:05:02

**High Band Edge - Frequency H**

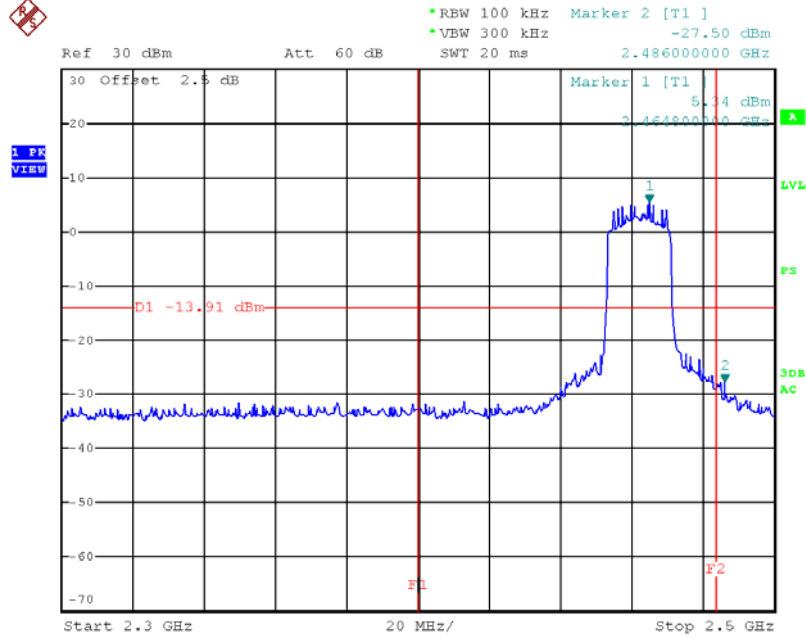

Date: 11.JUL.2014 17:57:46

### Spurious Emission 1MHz ~ 2.3GHz - Frequency H

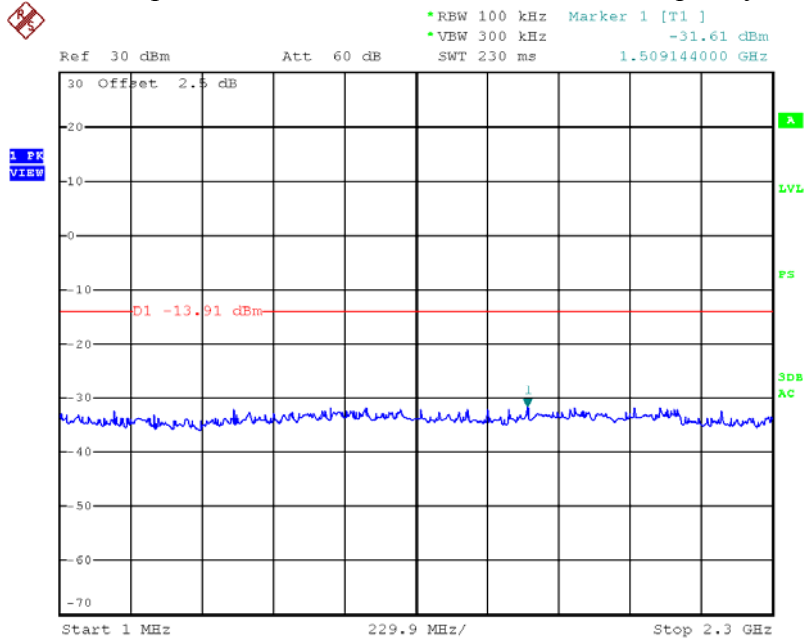

Date: 11.JUL.2014 17:55:56

### Spurious Emission 2.5GHz ~ 7GHz - Frequency H

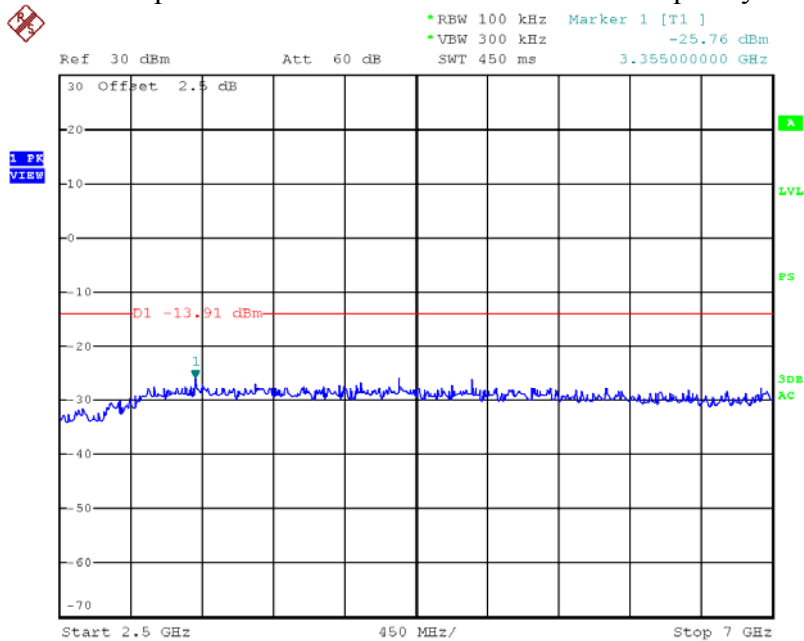

Date: 11.JUL.2014 17:59:27

### Spurious Emission 7GHz ~ 25GHz - Frequency H

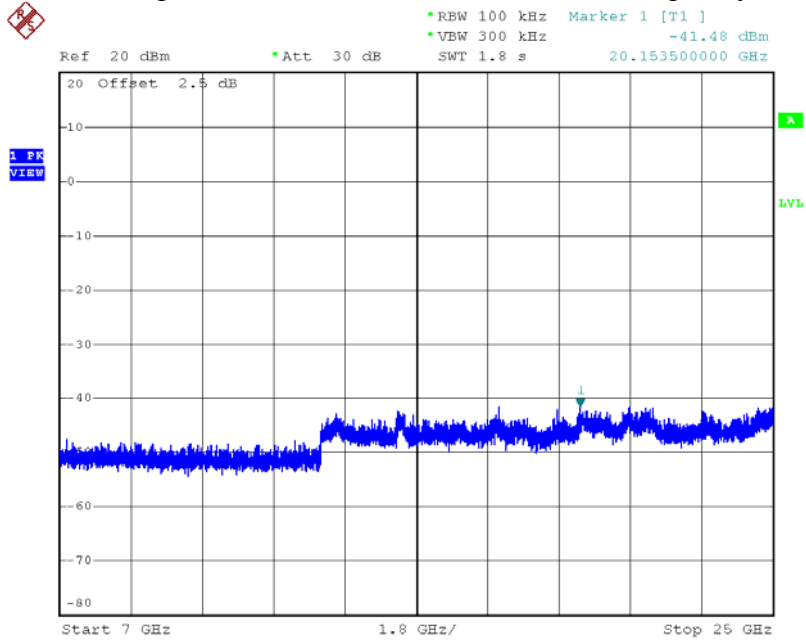

## 8. Power line conducted emission

Test result: PASS

### 8.1 Limit

Frequency of Emission (MHz)	Conducted Limit (dBuV)	
	QP	AV
0.15-0.5	66 to 56*	56 to 46 *
0.5-5	56	46
5-30	60	50

\* Decreases with the logarithm of the frequency.

### 8.2 Test configuration

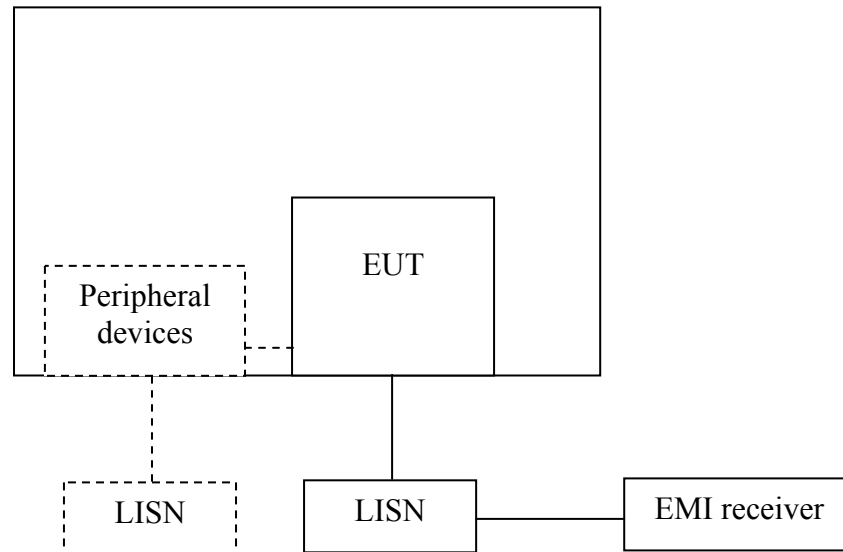

For table top equipment, wooden support is 0.8m height table

For floor standing equipment, wooden support is 0.1m height rack.

### **8.3 Test procedure and test set up**

The EUT are connected to the main power through a line impedance stabilization network (LISN). This provides a 50Ω/50uH coupling impedance for the measuring equipment. The peripheral devices are also connected to the main power through a LISN that provides a 50Ω/50uH coupling impedance with 50Ω termination.

Both sides (Line and Neutral) of AC line are checked for maximum conducted interference. In order to find the maximum emission, the relative positions of equipment and all of the interface cables must be changed according to ANSI C63.4 on conducted measurement. The bandwidth of the test receiver is set at 9 kHz.



### 8.4 Test protocol

Temperature : 25°C  
Relative Humidity : 55%

L Line:

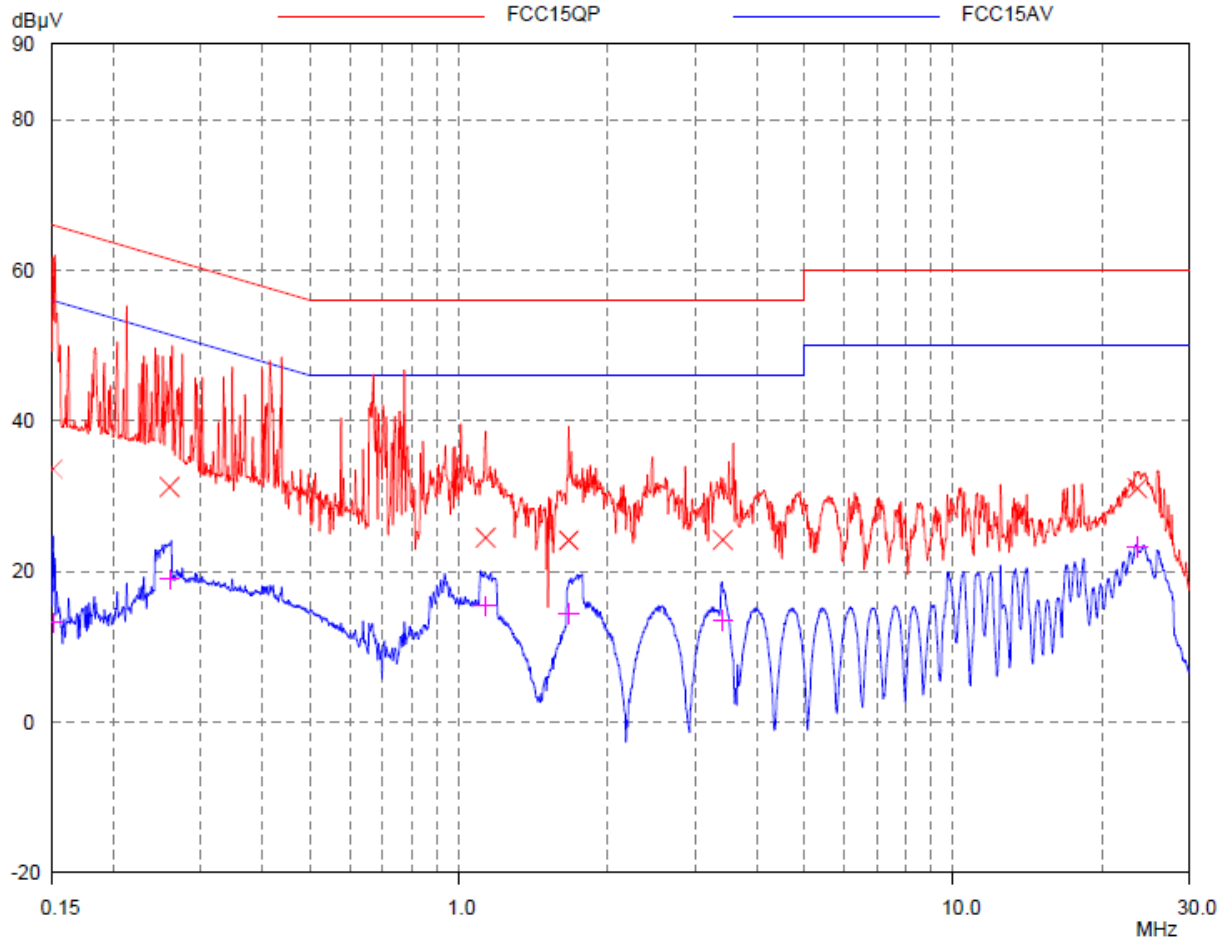

### Test Data:

Frequency (MHz)	Measure Level (dBµV)	Limit (dBµV)	Margin (dB)	Type
0.151	33.62	65.97	32.35	QP
0.259	31.22	61.46	30.24	QP
1.131	24.49	56.00	31.51	QP
1.665	24.14	56.00	31.86	QP
3.417	24.18	56.00	31.82	QP
23.589	31.05	60.00	28.95	QP
0.151	13.20	55.97	42.77	AV
0.259	18.97	51.46	32.49	AV
1.131	15.45	46.00	30.55	AV
1.665	14.40	46.00	31.60	AV
3.417	13.53	46.00	32.47	AV
23.589	23.28	50.00	26.72	AV

N line:

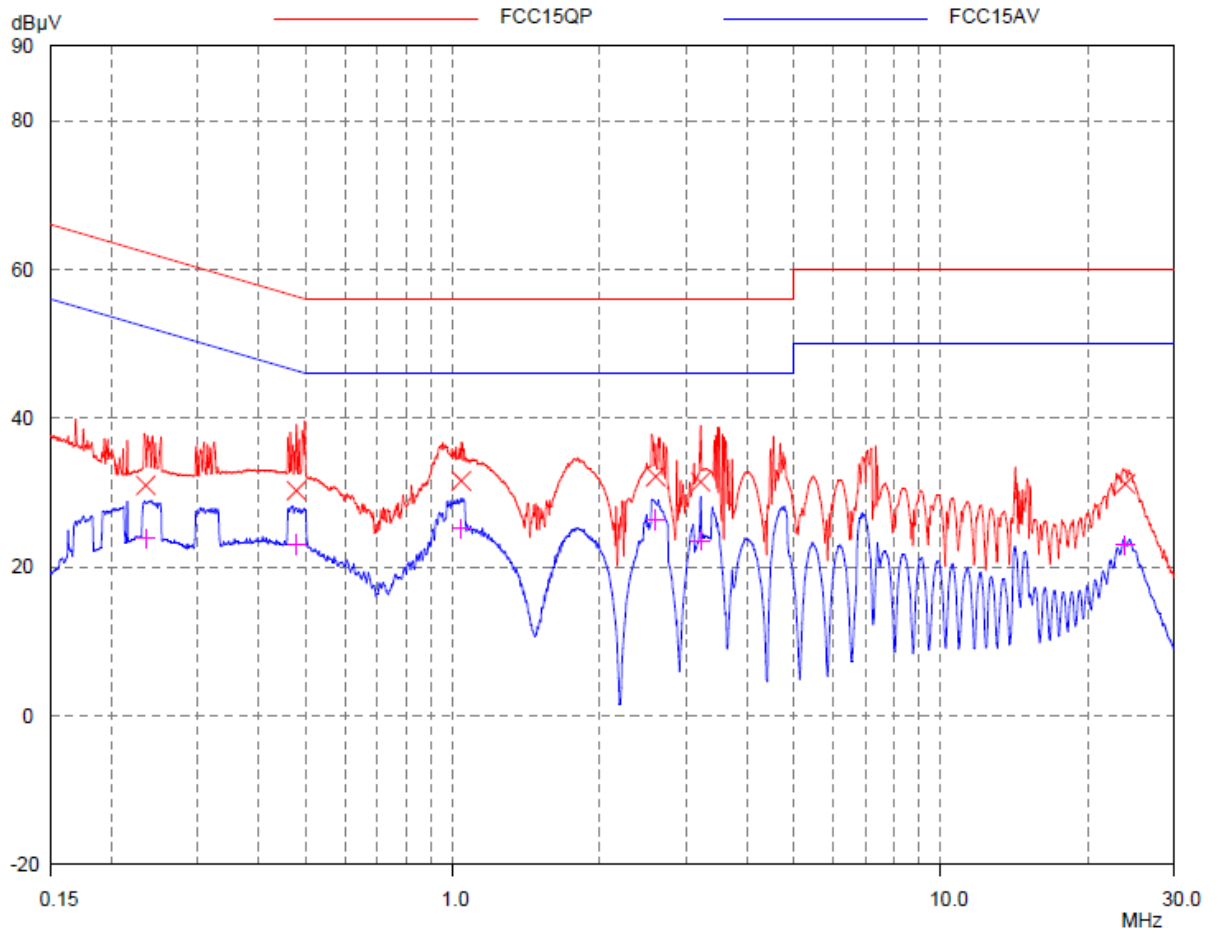

**Test Data:**

Frequency (MHz)	Measure Level (dBuV)	Limit (dBuV)	Margin (dB)	Type
0.235	30.98	62.29	31.31	QP
0.477	30.28	56.38	26.10	QP
1.040	31.59	56.00	24.41	QP
2.604	32.15	56.00	23.85	QP
3.218	31.45	56.00	24.55	QP
23.873	31.18	60.00	28.82	QP
0.235	23.84	52.29	28.45	AV
0.477	23.04	46.38	23.34	AV
1.040	25.20	46.00	20.80	AV
2.604	26.37	46.00	19.63	AV
3.218	23.53	46.00	22.47	AV
23.873	22.93	50.00	27.07	AV