

CERTIFICATION TEST REPORT

Report Number : 4791163219-FR1V1

Applicant : SEGI LIMITED
UNIT S, 3-F, HARIBEST INDUSTRIAL BUILDING,
45-47, AU PUI WAN STREET, SHATIN, NT, HONGKONG

Model : 1WG17R-AM

FCC ID : VA5REN500-1WAM

IC : 7087A-1WREN500AM

EUT Description : Keyless Entry System

Test Standard(s) : FCC 47 CFR PART 15 SUBPART C
INDUSTRY CANADA RSS-210 Issue 10
INDUSTRY CANADA RSS-GEN Issue 5

Date Of Issue:

2024-04-02

Prepared by:

UL KOREA LTD.

26th floor, 152, Teheran-ro, Gangnam-gu Seoul, 06236, Korea

Suwon Test Site: UL KOREA LTD. Suwon Laboratory

218 Maeyeong-ro, Yeongtong-gu,
Suwon-si, Gyeonggi-do, 16675, Korea

TEL: (031) 337-9902

FAX: (031) 213-5433

Revision History

<u>Rev.</u>	<u>Issue Date</u>	<u>Revisions</u>	<u>Revised By</u>
V1	2024-04-02	Initial issue	Yeonghwan Hong

TABLE OF CONTENTS

1. ATTESTATION OF TEST RESULTS	4
2. TEST METHODOLOGY	5
3. FACILITIES AND ACCREDITATION	5
4. CALIBRATION AND UNCERTAINTY	6
4.1. <i>MEASURING INSTRUMENT CALIBRATION</i>	<i>6</i>
4.2. <i>SAMPLE CALCULATION</i>	<i>6</i>
4.3. <i>MEASUREMENT UNCERTAINTY.....</i>	<i>6</i>
4.4. <i>DECISION RULE.....</i>	<i>6</i>
5. EQUIPMENT UNDER TEST.....	7
5.1. <i>EUT DESCRIPTION</i>	<i>7</i>
5.2. <i>MAXIMUM FIELD STRENGTH.....</i>	<i>7</i>
5.3. <i>DESCRIPTION OF AVAILABLE ANTENNAS</i>	<i>7</i>
5.4. <i>WORST-CASE CONFIGURATION AND MODE.....</i>	<i>7</i>
5.5. <i>DESCRIPTION OF TEST SETUP.....</i>	<i>8</i>
6. TEST AND MEASUREMENT EQUIPMENT	9
7. SUMMARY TABLE	10
8. CONDUCTED TEST RESULTS	11
8.1. <i>99% & 20 dB BANDWIDTH</i>	<i>11</i>
8.2. <i>AUTOMATICALLY DEACTIVATE.....</i>	<i>12</i>
9. RADIATED TEST RESULTS.....	13
9.1. <i>TRANSMITTER ABOVE 1 GHz</i>	<i>16</i>
9.2. <i>TRANSMITTER BELOW 1 GHz.....</i>	<i>18</i>
10. AC POWER LINE CONDUCTED EMISSIONS	20

1. ATTESTATION OF TEST RESULTS

COMPANY NAME: SEGI LIMITED
EUT DESCRIPTION: Keyless Entry System
MODEL NUMBER: 1WG17R-AM
SERIAL NUMBER: Identical prototype
DATE TESTED: 2024-01-25 ~ 2024-04-01;

APPLICABLE STANDARDS	
STANDARD	TEST RESULTS
CFR 47 Part 15 Subpart C RSS-GEN / RSS-210	Complies

UL KOREA LTD. tested the above equipment in accordance with the requirements set forth in the above standards. All indications of Pass/Fail in this report are opinions expressed by UL KOREA LTD. based on interpretations and/or observations of test results. Measurement Uncertainties were not taken into account and are published for informational purposes only. The test results show that the equipment tested is capable of demonstrating compliance with the requirements as documented in this report.

Note: The results documented in this report apply only to the tested sample, under the conditions and modes of operation as described herein. This document may not be altered or revised in any way unless done so by UL KOREA LTD. and all revisions are duly noted in the revisions section. Any alteration of this document not carried out by UL KOREA LTD. will constitute fraud and shall nullify the document. This report must not be used by the client to claim product certification, approval, or endorsement by IAS, any agency of the Federal Government, or any agency of any government.

Approved & Released For
UL KOREA LTD. By:

Tested By:



Seokhwan Hong
Suwon Lab Engineer
UL KOREA LTD.

Yeonghwan Hong
Suwon Lab Engineer
UL KOREA LTD.

2. TEST METHODOLOGY

1. FCC CFR 47 Part 2.
2. FCC CFR 47 Part 15.231
3. IC RSS-GEN Issue 5
4. IC RSS-210 Issue 10
5. ANSI C63.10-2013.

3. FACILITIES AND ACCREDITATION

The test sites and measurement facilities used to collect data are located at 218 Maeyeong-ro, Yeongtong-gu, Suwon-si, Gyeonggi-do, 16675, Korea. Line conducted emissions are measured only at the 218 address. The following table identifies which facilities were utilized for radiated emission measurements documented in this report. Specific facilities are also identified in the test results sections.

218 Maeyeong-ro	
<input type="checkbox"/>	Chamber 1(3m semi-anechoic chamber)
<input checked="" type="checkbox"/>	Chamber 2(3m semi-anechoic chamber)
<input type="checkbox"/>	Chamber 3(3m semi-anechoic chamber)

Used ISED Test Site Reg.(company number): 2324L
CAB Identifier: KR0161

UL Korea, Ltd. is accredited by IAS, Laboratory Code TL-637. The full scope of accreditation can be viewed at <https://www.iasonline.org/wp-content/uploads/2017/05/TL-637-cert-New.pdf>.

4. CALIBRATION AND UNCERTAINTY

4.1. MEASURING INSTRUMENT CALIBRATION

The measuring equipment utilized to perform the tests documented in this report has been calibrated in accordance with the manufacturer's recommendations, and is traceable to recognized national standards.

4.2. SAMPLE CALCULATION

Where relevant, the following sample calculation is provided:

$$\begin{aligned} \text{Field Strength (dBuV/m)} &= \text{Measured Voltage (dBuV)} + \text{Antenna Factor (dB/m)} + \\ &\text{Cable Loss (dB)} - \text{Preamp Gain (dB)} \\ 28.9 \text{ dBuV/m} &= 36.5 \text{ dBuV} + 18.7 \text{ dB/m} + 0.6 \text{ dB} - 26.9 \text{ dB} \end{aligned}$$

4.3. MEASUREMENT UNCERTAINTY

Where relevant, the following measurement uncertainty levels have been estimated for tests performed on the apparatus:

PARAMETER	UNCERTAINTY
Conducted Disturbance, 0.15 to 30 MHz	2.80 dB
Radiated Disturbance, 30 MHz to 1 GHz	3.92 dB
Radiated Disturbance, 1 GHz to 18 GHz	5.06 dB
Radiated Disturbance, 18 GHz to 40 GHz	6.02 dB

Uncertainty figures are valid to a confidence level of 95%.

4.4. DECISION RULE

Decision rule for statement(s) of conformity is based on Procedure 2, Clause 4.4.3 in IEC Guide 115:2021

5. EQUIPMENT UNDER TEST

5.1. EUT DESCRIPTION

The EUT is a Keyless Entry System and operating under FCC Part 15.231 & RSS-210 Annex A

5.2. MAXIMUM FIELD STRENGTH

The transmitter has a maximum fundamental field strength power as follows:

Frequency [MHz]	Maximum Fundamental field strength Power [dBuV/m]	
	PEAK	AVERAGE
433.92	80.37	68.24

5.3. DESCRIPTION OF AVAILABLE ANTENNAS

An intentional radiator antenna shall be designed to ensure that no antenna other than that furnished by the responsible party can be used with the device. The use of a permanently attached antenna or of an antenna that uses a unique coupling to the intentional radiator shall be considered sufficient to comply with the provisions of this section.

**The internal antenna was Permanently attached.
 Therefore this E.U.T Complies with the requirement of §15.203.**

The radio utilizes an internal antenna, with a maximum gain of -4.09 dBi

5.4. WORST-CASE CONFIGURATION AND MODE

Radiated emission was performed with the EUT set to transmit at the single frequency (433.92 MHz). Power line conducted emission was not performed since this device using un-rechargeable battery.

The fundamental and radiated spurious emission were investigated in three orthogonal orientations X, Y and Z. It was determined that below orientation was worst-case orientation for each antenna.

Antenna	Worst Case		
	X	Y	Z
Fundamental(433.92MHz)	-	-	O
Radiated spurious emission	Please see the tested data		

5.5. DESCRIPTION OF TEST SETUP

TEST SETUP

The EUT is a stand-alone unit during the tests.

SETUP DIAGRAM FOR TESTS (CONDUCTED TEST SETUP)

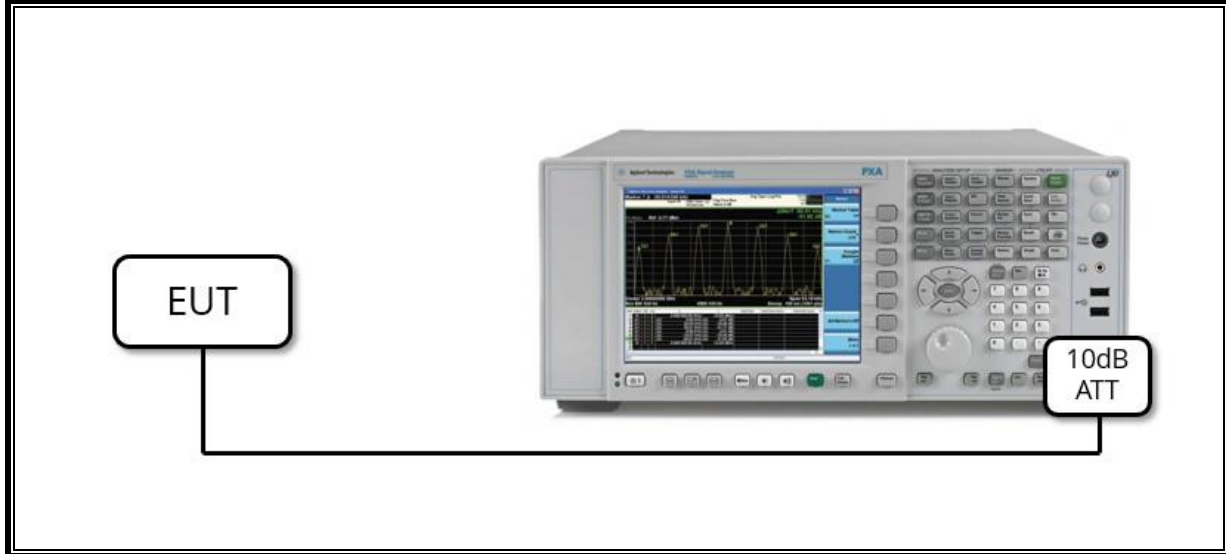

SETUP DIAGRAM FOR TESTS (RADIATED TEST SETUP)

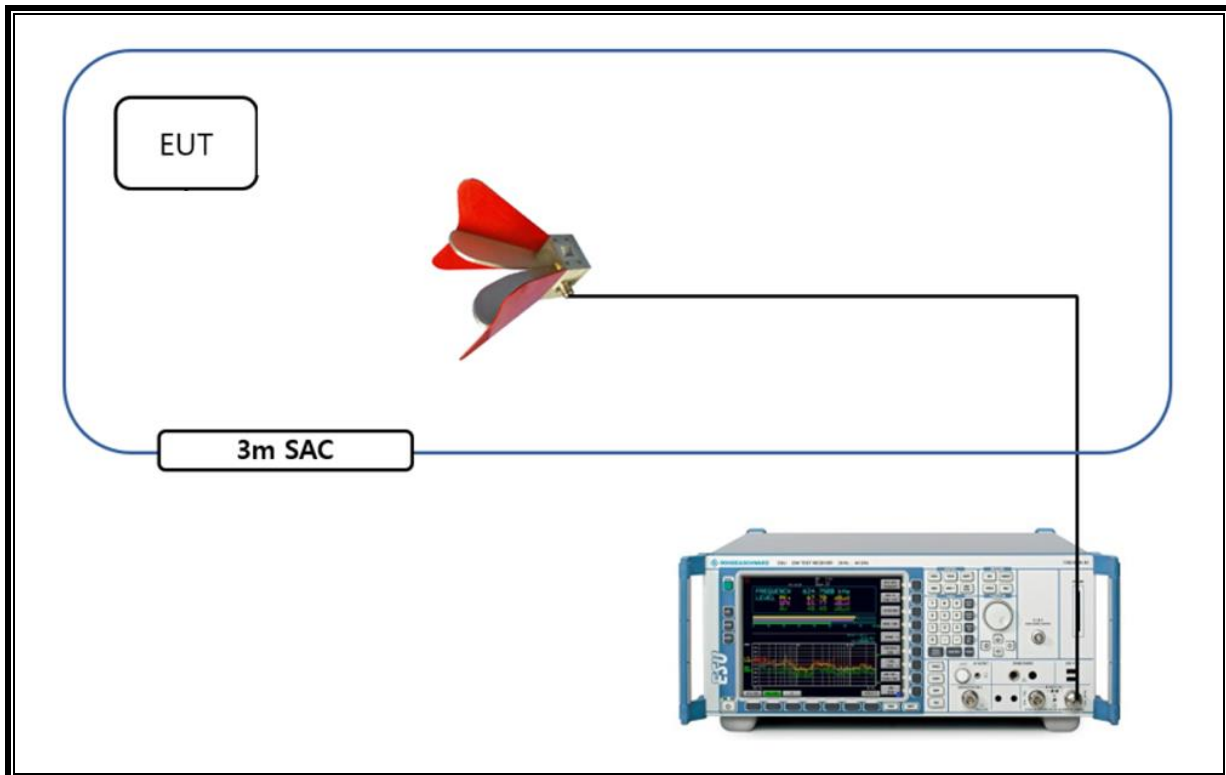

6. TEST AND MEASUREMENT EQUIPMENT

The following test and measurement equipment was utilized for the tests documented in this report:

Test Equipment List				
Description	Manufacturer	Model	S/N	Cal Due
Antenna, Bilog, 30MHz-1GHz	SCHWARZBECK	VULB9163	750	2024-08-15
Antenna, Horn, 18 GHz	ETS	3117	00168717	2024-08-21
Antenna, Horn, 40 GHz	ETS	3116C	00166155	2024-08-02
Preamplifier	ETS	3116C-PA	00168841	2024-07-25
Preamplifier, 1000 MHz	Sonoma	310N	341282	2024-07-24
Preamplifier, 18 GHz	Miteq	AFS42-00101800-25-S-42	2029169	2024-07-24
Spectrum Analyzer, 44 GHz	Agilent / HP	N9030A	MY54170614	2024-07-25
Spectrum Analyzer, 44 GHz	Agilent / HP	N9030A	MY54490312	2024-07-24
Spectrum Analyzer, 44 GHz	KEYSIGHT	N9040B	MY60080268	2025-01-03
Average Power Sensor	Agilent / HP	U2000A	MY54270007	2024-07-23
Average Power Sensor	Agilent / HP	U2000A	MY54260010	2024-07-24
Attenuator	PASTERNAK	PE7087-10	A001	2024-07-23
Attenuator	PASTERNAK	PE7087-10	A008	2024-07-27
EMI Test Receive, 40 GHz	R&S	ESU40	100439	2024-07-23
EMI Test Receive, 40 GHz	R&S	ESU40	100457	2024-07-24
EMI Test Receive, 3 GHz	R&S	ESR3	101832	2024-07-23
High Pass Filter 1.2GHz	Micro-Tronics	HPM50108-02	G005	2024-07-23
High Pass Filter 1.2GHz	Micro-Tronics	HPM50108-02	G006	2024-07-23
High Pass Filter 2.8GHz	Micro-Tronics	HPM50111-02	010	2024-07-24
High Pass Filter 2.8GHz	Micro-Tronics	HPM50111-02	011	2024-07-24
Low Pass Filter 5GHz	Micro-Tronics	LPS17541	009	2024-07-23
High Pass Filter 3GHz	Micro-Tronics	HPM17543	010	2024-07-23
High Pass Filter 6GHz	Micro-Tronics	HPS17542	021	2024-07-24
Antenna, Loop, 9kHz-30MHz	R&S	HFH2-Z2	100418	2025-09-06
UL Software				
Description	Manufacturer	Model	Version	
Radiated software	UL	UL EMC	Ver 9.5	
AC Line Conducted software	UL	UL EMC	Ver 9.5	

7. SUMMARY TABLE

FCC Part Section	IC Section	Test Description	Test Limit	Test Condition	Test Result
15.231 (c)	-	20dB bandwidth	no wider than 0.25% of the center frequency for device	Conducted	PASS
-	RSS-210 [A1.3]	Occupied bandwidth(99%)	no wider than 0.25% of the center frequency for device		PASS
15.231 (a)(1)	RSS-210 [A1.1]	Automatically deactivate	< 5s		PASS
15.231 (b)	RSS-210 [A1.2]	Field strength of fundamental and spurious emissions	Fundamental: < 100.8 dBuV/m(Pk) < 80.8 dBuV/m(Av)	Radiated	PASS
			Spurious emission: < 80.8 dBuV/m(Pk) < 60.8 dBuV/m(Av)		
15.205, 15.209	RSS-GEN [8.9] & [8.10]	General field strength limits(restricted bands and radiated emission limits)	Spurious emission: < 74 dBuV/m(Pk) < 54 dBuV/m(Av)		
15.207 (a)	RSS-GEN [8.8]	AC Power Line conducted emissions	Section 11	Power Line conducted	N/P

Note. AC Power line conducted emission was not performed since this device using un-rechargeable battery.

8. CONDUCTED TEST RESULTS

8.1. 99% & 20 dB BANDWIDTH

LIMITS

The bandwidth of the emission shall be no wider than 0.25 % of the center frequency for devices operating above 70 MHz and below 900 MHz. For devices operating above 900 MHz, the emission shall be no wider than

TEST PROCEDURE

The transmitter output is connected to the spectrum analyzer. The RBW is set to 1% to 3% of the 99 % bandwidth and to 1% of the span. The VBW is set to 3 times the RBW. The sweep time is coupled. The spectrum analyzer internal 99% bandwidth function is utilized.

RESULTS

Channel	Frequency [MHz]	20 dB Bandwidth [kHz]	99 % Bandwidth [kHz]	Limit [kHz]
Single channel	433.92	61.73	146.15	1084.80

20 dB & 99% BANDWIDTH PLOTS

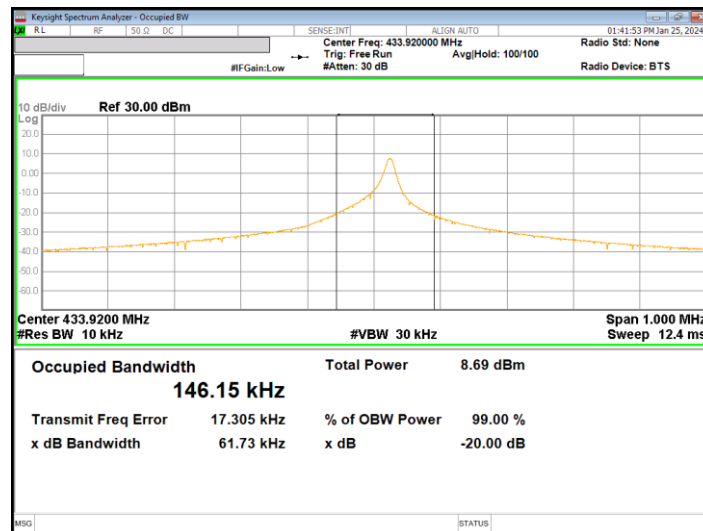

8.2. AUTOMATICALLY DEACTIVATE

LIMITS

FCC §15.231 (a) & RSS-210 Annex A.1.1

A manually operated transmitter shall employ a switch that will automatically deactivate the transmitter within not more than 5 seconds of being released.

RESULTS

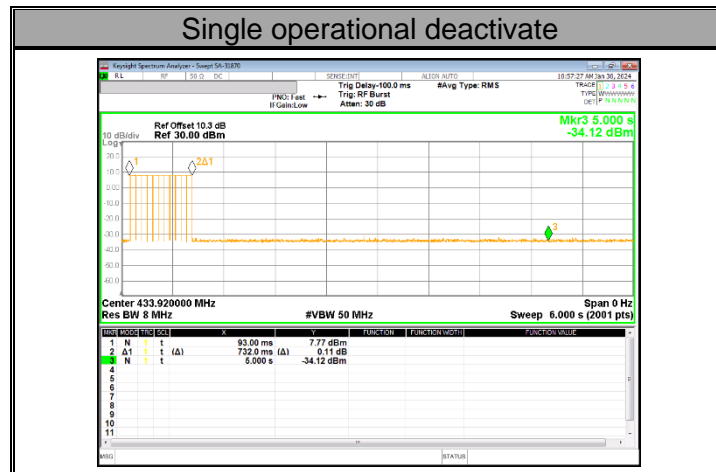

Single operational time[s]	Limit[s]
0.732	5

9. RADIATED TEST RESULTS

LIMITS

FCC §15.205 and §15.209, §15.231 (b), RSS-210 Annex A1.2

Limits for radiated disturbance of an intentional radiator		
Frequency range (MHz)	Limits (µV/m)	Measurement Distance (m)
0.009 – 0.490	2400 / F (kHz)	300
0.490 – 1.705	24000 / F (kHz)	30
1.705 – 30.0	30	30
30 – 88	100**	3
88 - 216	150**	3
216 – 960	200**	3
Above 960	500	3

** Except as provided in paragraph (g), fundamental emissions from intentional radiators operating under this section shall not be located in the frequency bands 54-72 MHz, 76-88 MHz, 174-216 MHz or 470-806 MHz. However, operation within these frequency bands is permitted under other sections of this part, e.g. §§ 15.231 and 15.241.

FCC Part 15.205 (a) : Only spurious emissions are permitted in any of the frequency bands listed below :

MHz	MHz	MHz	MHz	GHz	GHz
0.009 ~ 0.110	8.41425 ~ 8.41475	108 ~ 121.94	1300 ~ 1427	4.5 ~ 5.15	14.47 ~ 14.5
0.495 ~ 0.505	12.29 ~ 12.293	123 ~ 138	1435 ~ 1626.5	5.35 ~ 5.46	15.35 ~ 16.2
2.1735 ~ 2.1905	12.51975 ~ 12.52025	149.9 ~ 150.05	1645.5 ~ 1646.5	7.25 ~ 7.75	17.7 ~ 21.4
4.125 ~ 4.128	12.57675 ~ 12.57725	156.52475 ~	1660 ~ 1710	8.025 ~ 8.5	22.01 ~ 23.12
4.17725 ~ 4.17775	13.36 ~ 13.41	156.52525	1718.8 ~ 1722.2	9.0 ~ 9.2	23.6 ~ 24.0
4.20725 ~ 4.20775	16.42 ~ 16.423	156.7 ~ 156.9	2200 ~ 2300	9.3 ~ 9.5	31.2 ~ 31.8
6.215 ~ 6.218	16.69475 ~ 16.69525	162.0125 ~	2310 ~ 2390	10.6 ~ 12.7	36.43 ~ 36.5
6.26775 ~ 6.26825	16.80425 ~ 16.80475	167.17	2483.5 ~ 2500	13.25 ~ 13.4	Above 38.6
6.31175 ~ 6.31225	25.5 ~ 25.67	167.72 ~ 173.2	2655 ~ 2900		
8.291 ~ 8.294	37.5 ~ 38.25	240 ~ 285	3260 ~ 3267		
8.362 ~ 8.366	73 ~ 74.6	322 ~ 335.4	3332 ~ 3339		
8.37625 ~ 8.38675	74.8 ~ 75.2	399.90 ~ 410	3345.8 ~ 3358		
		608 ~ 614	3600 ~ 4400		
		960 ~ 1240			

▪ FCC Part 15.205(b) : The field strength of emissions appearing within these frequency bands shall not exceed the limits shown in §15.209. At frequencies equal to or less than 1000 MHz, compliance with the limits in §15.209 shall be demonstrated using measurement instrumentation employing a CISPR quasi-peak detector. Above 1000 MHz, compliance with the emission limits in §15.209 shall be demonstrated based on the average value of the measured emissions. The provisions in §15.35 apply to these measurements.

FCC §15.231 & RSS-210 Annex A1.2		
Fundamental Frequency (MHz)		Field strength of fundamental (µV/m)
For FCC	For IC(RSS-Gen)	
40.66-40.70	-	2,250
70-130	70-130	1,250
130-174	130-174	1,250 to 3,750*
174-260	174-260	3,750
260-470	260-470	3,750 to 12,500*
Above 470	Above 470	12,500

* Linear interpolation.

TEST PROCEDURE

The EUT is placed on a non-conducting table 80 cm above the ground plane for below 1 GHz and 150 cm for above 1 GHz. The antenna to EUT distance is 3 meters. The EUT is configured in accordance with ANSI C63.10. The EUT is set to transmit in a continuous mode.

For measurements below 1 GHz the resolution bandwidth is set to 100 kHz for peak detection measurements or 120 kHz for quasi-peak detection measurements. Peak detection is used unless otherwise noted as quasi-peak.

For measurements above 1 GHz the resolution bandwidth is set to 1 MHz; the video bandwidth is set to 3 MHz for peak measurements and add duty cycle factor for average calculations.

$$\begin{aligned} \text{Total Average Factor} &= 20 \log \frac{24.75}{100} \text{ dB} \\ &= \mathbf{-12.13 \text{ dB}} \end{aligned}$$

Total Average Factor = -12.13 dB

Declared Worst Data Format of 1 Word

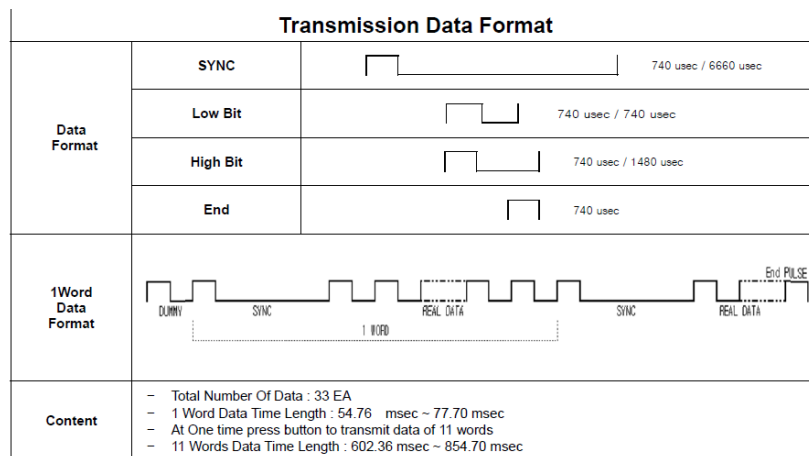

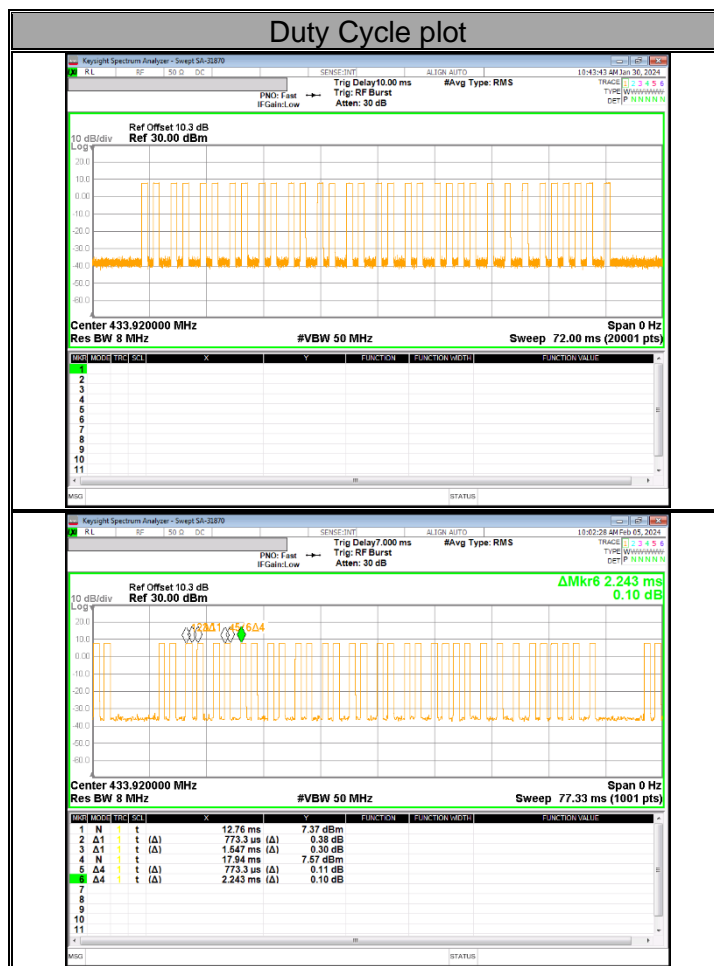

Pre-scans to detect harmonic and spurious emissions, the resolution bandwidth is set to 1 MHz; the video bandwidth is set to 30 kHz for peak measurements.

The spectrum from 30MHz to 1GHz is investigated with the transmitter set to 433.92 MHz. (From 1 GHz to 5 GHz, test was performed with the EUT set to transmit at the position with highest output power)

The frequency range of interest is monitored at a fixed antenna height and EUT azimuth. The EUT is rotated through 360 degrees to maximize emissions received. The antenna is scanned from 1 to 4 meters above the ground plane to further maximize the emission. Measurements are made with the antenna polarized in both the vertical and the horizontal positions.

Note : Emission was pre-scanned from 9 kHz to 30 MHz; No emissions were detected which was at least 20dB below the specification limit (consider distance correction factor). Per FCC part 15.31(o), test results were not reported.

Although these tests were performed other than open field test site, adequate comparison measurements were confirmed against 30 m open field test site. Therefore sufficient tests were made to demonstrate that the alternative site produces results that correlate with the one of tests made in an open field based on KDB 414788.

9.1. TRANSMITTER ABOVE 1 GHz

HARMONICS AND SPURIOUS EMISSIONS

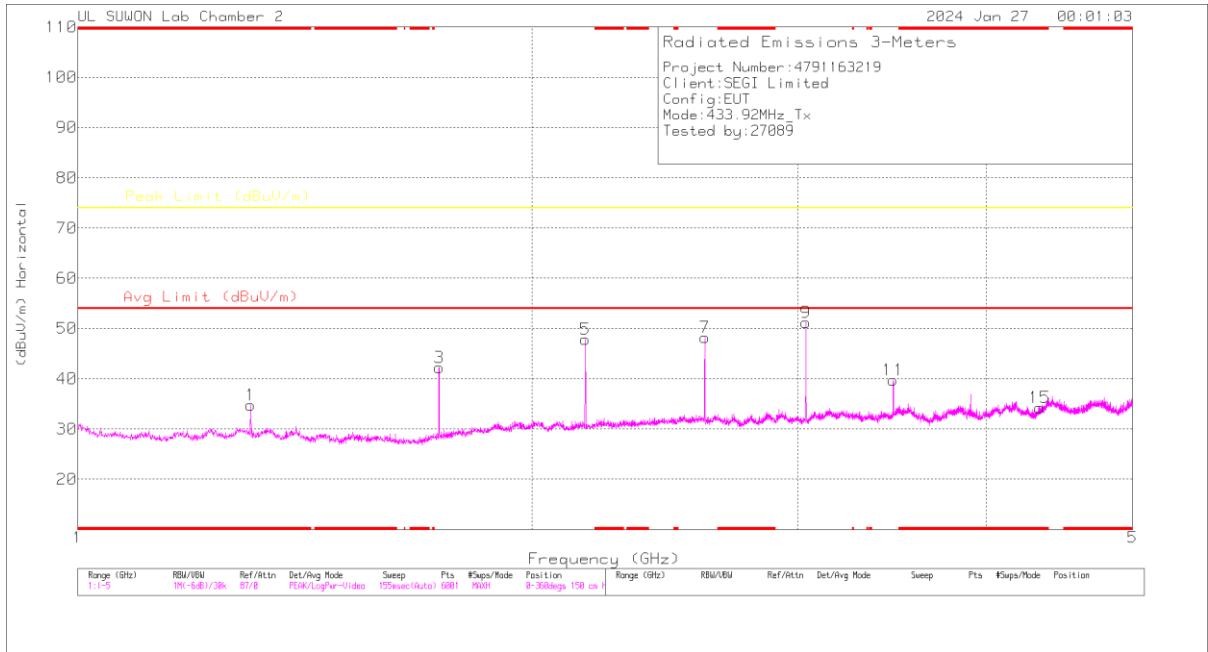

HORIZONTAL

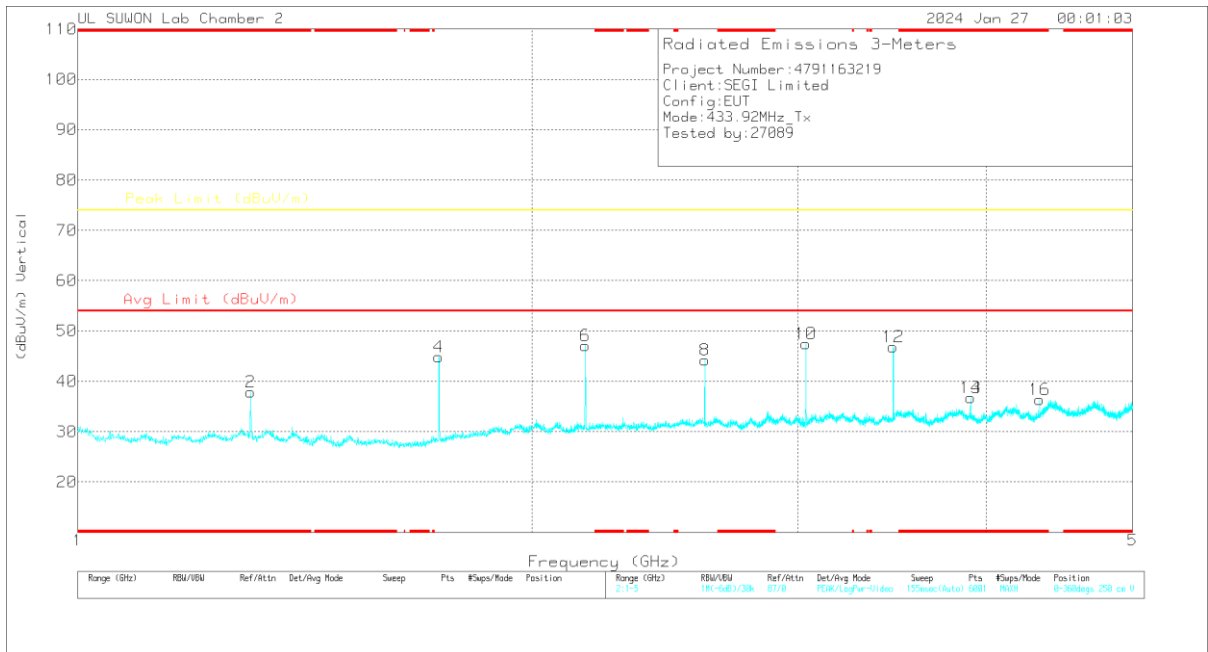

VERTICAL

Spurious Data

Freq. [MHz]	Axis	Frequency [GHz]	Reading [dBuV]	Detector Mode	ANT Factor	Loss [dB]	DC Corr [dB]	Result [dBuV/m]	AV Limit [dBuV/m]	AV Margin [dB]	PK Limit [dBuV/m]	PK Margin [dB]	Azimuth [Degs]	Height [cm]	Polarity	
433.92	Z	* 1.30133	35.07	PK2	29.50	-29.80	-	34.77	-	-	74.00	-39.23	112	138	H	
		* 1.30133	35.07	PK2	29.50	-29.80	-12.13	-	22.64	54.00	-31.36	-	-	112	138	H
		1.73600	42.77	PK2	28.90	-29.40	-	-	42.27	-	-	74.00	-31.73	103	382	H
		1.73600	42.77	PK2	28.90	-29.40	-12.13	-	30.14	54.00	-23.86	-	-	103	382	H
		2.16933	44.86	PK2	31.50	-28.50	-	-	47.86	-	-	74.00	-26.14	343	345	H
		2.16933	44.86	PK2	31.50	-28.50	-12.13	-	35.73	54.00	-18.27	-	-	343	345	H
		2.60333	44.19	PK2	32.10	-28.10	-	-	48.19	-	-	74.00	-25.81	199	343	H
		2.60333	44.19	PK2	32.10	-28.10	-12.13	-	36.06	54.00	-17.94	-	-	199	343	H
		3.03733	46.85	PK2	32.50	-28.10	-	-	51.25	-	-	74.00	-22.75	47	385	H
		3.03733	46.85	PK2	32.50	-28.10	-12.13	-	39.12	54.00	-14.88	-	-	47	385	H
		3.47133	34.04	PK2	32.70	-27.00	-	-	39.74	-	-	74.00	-34.26	34	378	H
		3.47133	34.04	PK2	32.70	-27.00	-12.13	-	27.61	54.00	-26.39	-	-	34	378	H
		* 4.33867	27.98	PK2	33.50	-27.20	-	-	34.28	-	-	74.00	-39.72	103	382	H
		* 4.33867	27.98	PK2	33.50	-27.20	-12.13	-	22.15	54.00	-31.85	-	-	103	382	H
		* 1.30133	38.19	PK2	29.50	-29.80	-	-	37.89	-	-	74.00	-36.11	343	345	H
		* 1.30133	38.19	PK2	29.50	-29.80	-12.13	-	25.76	54.00	-28.24	-	-	343	345	H
		1.73533	45.35	PK2	28.90	-29.40	-	-	44.85	-	-	74.00	-29.15	199	343	H
		1.73533	45.35	PK2	28.90	-29.40	-12.13	-	32.72	54.00	-21.28	-	-	199	343	H
		2.16933	44.12	PK2	31.50	-28.50	-	-	47.12	-	-	74.00	-26.88	112	138	V
		2.16933	44.12	PK2	31.50	-28.50	-12.13	-	34.99	54.00	-19.01	-	-	112	138	V
		2.60400	40.29	PK2	32.10	-28.20	-	-	44.19	-	-	74.00	-29.81	103	382	V
		2.60400	40.29	PK2	32.10	-28.20	-12.13	-	32.06	54.00	-21.94	-	-	103	382	V
		3.03733	43.03	PK2	32.50	-28.10	-	-	47.43	-	-	74.00	-26.57	343	345	V
		3.03733	43.03	PK2	32.50	-28.10	-12.13	-	35.30	54.00	-18.70	-	-	343	345	V
		3.47133	41.17	PK2	32.70	-27.00	-	-	46.87	-	-	74.00	-27.13	199	343	V
		3.47133	41.17	PK2	32.70	-27.00	-12.13	-	34.74	54.00	-19.26	-	-	199	343	V
		* 3.90533	31.15	PK2	33.20	-27.60	-	-	36.75	-	-	74.00	-37.25	47	385	V
		* 3.90533	31.15	PK2	33.20	-27.60	-12.13	-	24.62	54.00	-29.38	-	-	47	385	V
		* 4.33934	30.09	PK2	33.50	-27.20	-	-	36.39	-	-	74.00	-37.61	34	378	V
		* 4.33934	30.09	PK2	33.50	-27.20	-12.13	-	24.26	54.00	-29.74	-	-	34	378	V

9.2. TRANSMITTER BELOW 1 GHz

FUNDAMENTAL AND SPURIOUS EMISSIONS

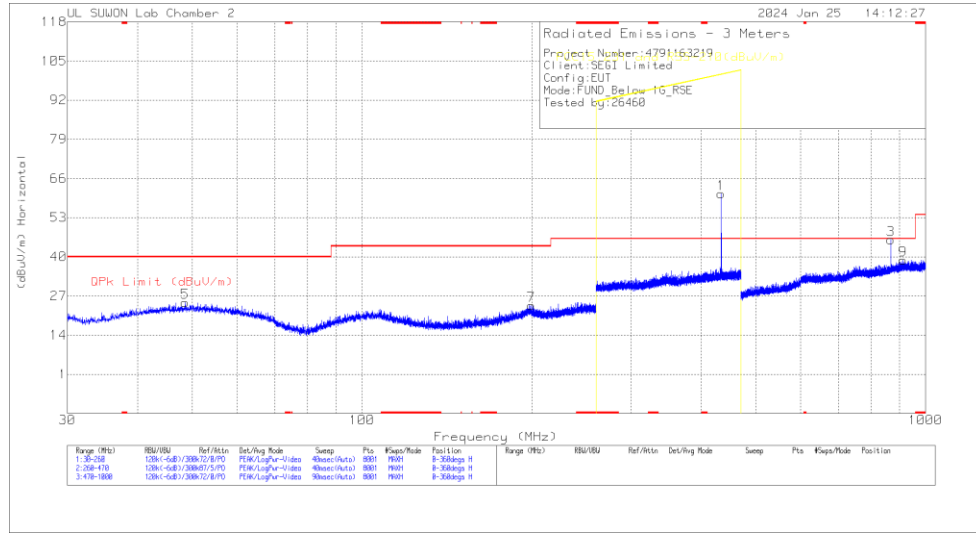

HORIZONTAL

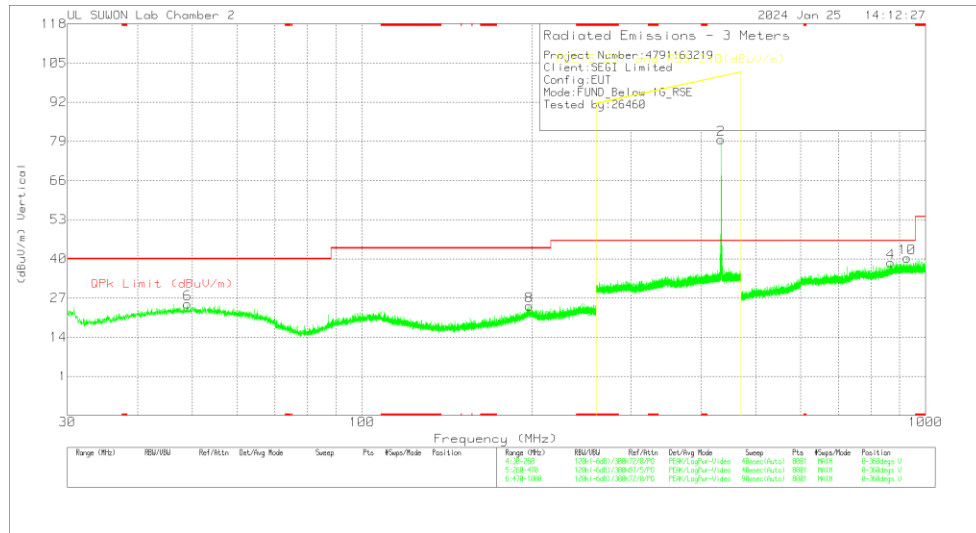

VERTICAL

Fundamental Data

Freq. [MHz]	Axis	Frequency [GHz]	Reading [dBuV]	Detector Mode	ANT Factor	Loss [dB]	DC Corr [dB]	Result dBuV/m	QP Limit dBuV/m	QP Margin [dB]	AV Limit dBuV/m	AV Margin [dB]	PK Limit dBuV/m	PK Margin [dB]	Azimuth [Degs]	Height [cm]	Polarity	
433.92	X	433.920	55.16	Pk	21.80	2.60	-	79.56	-	-	-	-	100.80	-21.24	0-360	200	H	
		433.920	55.16	Av	21.80	2.60	-12.13	67.43	-	-	80.80	-13.37	-	-	0-360	200	H	
		433.920	47.80	Pk	21.80	2.60	-	72.20	-	-	-	-	-	100.80	-28.60	0-360	100	V
		433.920	47.80	Av	21.80	2.60	-12.13	60.07	-	-	80.80	-20.73	-	-	0-360	100	V	
433.92	Y	433.920	54.70	Pk	21.80	2.60	-	79.10	-	-	-	-	100.80	-21.70	0-360	100	H	
		433.920	54.70	Av	21.80	2.60	-12.13	66.97	-	-	80.80	-13.83	-	-	0-360	100	H	
		433.920	47.22	Pk	21.80	2.60	-	71.62	-	-	-	-	-	100.80	-29.18	0-360	100	V
		433.920	47.22	Av	21.80	2.60	-12.13	59.49	-	-	80.80	-21.31	-	-	0-360	100	V	
433.92	Z	433.920	36.70	Pk	21.80	2.60	-	61.10	-	-	-	-	100.80	-39.70	0-360	100	H	
		433.920	36.70	Av	21.80	2.60	-12.13	48.97	-	-	80.80	-31.83	-	-	0-360	100	H	
		433.920	55.97	Pk	21.80	2.60	-	80.37	-	-	-	-	-	100.80	-20.43	0-360	200	V
		433.920	55.97	Av	21.80	2.60	-12.13	68.24	-	-	80.80	-12.56	-	-	0-360	200	V	

Spurious Data

Axis	Frequency [GHz]	Reading [dBuV]	Detector Mode	ANT Factor	Loss [dB]	DC Corr [dB]	Result dBuV/m	QP Limit dBuV/m	QP Margin [dB]	AV Limit dBuV/m	AV Margin [dB]	PK Limit [dBuV/m]	PK Margin [dB]	Azimuth [Degs]	Height [cm]	Polarity
Z	48.57	3.87	Pk	20.10	0.80	-	24.77	40.00	-15.23	-	-	-	-	0-360	300	H
	199.60	4.39	Pk	17.70	1.70	-	23.79	43.52	-19.73	-	-	-	-	0-360	300	H
	867.90	14.46	Pk	27.40	3.80	-	45.66	-	-	-	-	80.80	-35.14	0-360	100	H
	867.90	14.46	Pk	27.40	3.80	-	45.66	-	-	60.80	-15.14	-	-	0-360	100	H
	911.56	7.25	Pk	27.70	3.90	-	38.85	46.02	-7.17	-	-	80.80	-41.95	0-360	100	H
	49.00	4.09	Pk	20.10	0.80	-	24.99	40.00	-15.01	-	-	-	-	0-360	200	V
	198.13	4.59	Pk	18.00	1.70	-	24.29	43.52	-19.23	-	-	-	-	0-360	400	V
	867.90	7.51	Pk	27.40	3.80	-	38.71	-	-	-	-	80.80	-42.09	0-360	100	V
	867.90	7.51	Pk	27.40	3.80	-	38.71	-	-	60.80	-22.09	-	-	0-360	100	V
	927.59	8.60	Pk	27.70	3.90	-	40.20	46.02	-5.82	-	-	80.80	-40.60	0-360	100	V

10. AC POWER LINE CONDUCTED EMISSIONS

LIMITS

FCC §15.207 (a) & RSS-GEN[8.8]

Frequency of Emission (MHz)	Conducted Limit (dBuV)	
	Quasi-peak	Average
0.15-0.5	66 to 56	56 to 46
0.5-5	56	46
5-30	60	50

* Decreases with the logarithm of the frequency.

TEST PROCEDURE

The EUT is placed on a non-conducting table 40 cm from the vertical ground plane and 80 cm above the horizontal ground plane. The EUT is configured in accordance with ANSI C63.10.

The receiver is set to a resolution bandwidth of 9 kHz. Peak detection is used unless otherwise noted as quasi-peak or average.

Line conducted data is recorded for both NEUTRAL and HOT lines.

RESULTS: N/P

Note. EUT use Non-rechargeable battery.

END OF TEST REPORT