



HCT CO., LTD.

CERTIFICATE OF COMPLIANCE FCC Certification

Applicant Name:
SEGI LIMITED

Date of Issue:
July 11, 2011

Address:
henfiapucun, Liaobu Town, Dongguan City, Guangdong
Dongguan City, 186 China

Location:
HCT CO., LTD., 105-1, Jangam-ri, Majang-Myeon, Icheon-si, Kyunggi-Do, Korea

Test Report No.: HCTR1107FR12

HCT FRN: 0005866421

FCC ID: VA5GT1000

APPLICANT: SEGI LIMITED

FCC Model(s): GT1000
EUT Type: Modem
FCC Classification: PCS Licensed Transmitter (PCB)
FCC Rule Part(s): §22, §24, §2
Tx Frequency: 824.20 - 848.80 MHz (GSM850)
1 850.20 - 1 909.80 MHz (GSM1900)
Rx Frequency: 869.20 - 893.80 MHz (GSM850)
1 930.20 - 1 989.80 MHz (GSM1900)

Max. RF Output Power: 1.253 W ERP GPRS850 (30.98 dBm) / 1.396 W EIRP GPRS1900 (31.45 dBm)

Emission Designator(s): 250KGXW (GPRS850) 244KGXW (GPRS1900)

The measurements shown in this report were made in accordance with the procedures specified in §2.947. I assume full responsibility for the accuracy and completeness of these measurements, and for the qualifications of all persons taking them.

HCT CO., LTD. Certifies that no party to this application has subject to a denial of Federal benefits that includes FCC benefits pursuant to section 5301 of the Anti-Drug Abuse Act of 1998, 21 U.S.C. 853(a)

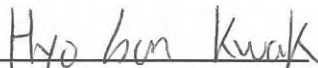
Report prepared by
: Hyo Sun Kwak
Test engineer of RF Team

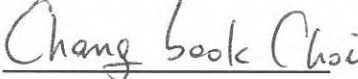
Approved by
: Chang Seok Choi
Manager of RF Team

This report only responds to the tested sample and may not be reproduced, except in full, without written approval of the HCT Co., Ltd.

FCC CERTIFICATION REPORT			www.hct.co.kr
Test Report No. HCTR1107FR12	Date of Issue: July 11, 2011	EUT Type: Modem	FCC ID: VA5GT1000

Version

TEST REPORT NO.	DATE	DESCRIPTION
HCTR1107FR12	July 11, 2011	First Approval Report

Table of Contents

70

1. GENERAL INFORMATION		4
2. INTRODUCTION		5
2.1. EUT DESCRIPTION.....		5
2.2. MEASURING INSTRUMENT CALIBRATION.....		5
2.3. TEST FACILITY		5
3. DESCRIPTION OF TESTS		6
3.1 EFFECTIVE RADIATED POWER/EQUIVALENT ISOTROPIC RADIATED POWER.....		6
3.2 PEAK- TO- AVERAGE RATIO		7
3.3 OCCUPIED BANDWIDTH.		8
3.4 SPURIOUS AND HARMONIC EMISSIONS AT ANTENNA TERMINAL.....		9
3.5 RADIATED SPURIOUS AND HARMONIC EMISSIONS		10
3.6 FREQUENCY STABILITY / VARIATION OF AMBIENT TEMPERATURE		11
4. LIST OF TEST EQUIPMENT		12
5. SUMMARY OF TEST RESULTS		13
6. SAMPLE CALCULATION		14
7. TEST DATA		15
7.1 CONDUCTED OUTPUT POWER		15
7.2 PEAK-TO-AVERAGE RATIO		15
7.3 OCCUPIED BANDWIDTH		16
7.4 CONDUCTED SPURIOUS EMISSIONS		17
7.4.1 BAND EDGE.....		17
7.5 EFFECTIVE RADIATED POWER OUTPUT (GSM).....		18
7.6 EQUIVALENT ISOTROPIC RADIATED POWER (GSM)		19
7.7 RADIATED SPURIOUS EMISSIONS		20
7.7.1 RADIATED SPURIOUS EMISSIONS (GSM850).....		20
7.7.2 RADIATED SPURIOUS EMISSIONS (GSM1900).....		21
7.8 FREQUENCY STABILITY / VARIATION OF AMBIENT TEMPERATURE		22
7.8.1 FREQUENCY STABILITY (GSM850)		22
7.8.2 FREQUENCY STABILITY (GSM1900)		23
8. TEST PLOTS.....		24

FCC CERTIFICATION REPORT			www.hct.co.kr
Test Report No. HCTR1107FR12	Date of Issue: July 11, 2011	EUT Type: Modem	FCC ID: VA5GT1000



MEASUREMENT REPORT

1. GENERAL INFORMATION

Applicant Name: SEGI LIMITED

Address: henfiapucun, Liaobu Town, Dongguan City, Guangdon Dongguan City, 186 China

FCC ID: VA5GT1000

Application Type: Certification

FCC Classification: PCS Licensed Transmitter (PCB)

FCC Rule Part(s): §22, §24, §2

EUT Type: Modem

FCC Model(s): GT1000

Tx Frequency: 824.20 - 848.80 MHz (GSM850)
1 850.20 - 1 909.80 MHz (GSM1900)

Rx Frequency: 869.20 - 893.80 MHz (GSM850)
1 930.20 - 1 989.80 MHz (GSM1900)

Max. RF Output Power: 1.253 W ERP GPRS850 (30.98 dBm) / 1.396 W EIRP GPRS1900 (31.45 dBm)

Emission Designator(s): 250KGXW (GSM850) 244KGXW (GSM1900)

Antenna Specification Manufacturer: LS Mtron Co. Ltd.
Antenna type: Internal Antenna
Peak Gain: 0.18 dBi

Date(s) of Tests: July 04, 2011 ~ July 08, 2011

Attention: Name: Youngil Chang
Phone #: +82-32-623-5550-25

FCC CERTIFICATION REPORT			www.hct.co.kr
Test Report No. HCTR1107FR12	Date of Issue: July 11, 2011	EUT Type: Modem	FCC ID: VA5GT1000



2. INTRODUCTION

2.1. EUT DESCRIPTION

The SEGI LIMITED GT1000 Modem consists of GSM850, GSM1900 and GPRS Class10.

2.2. MEASURING INSTRUMENT CALIBRATION

The measuring equipment, which was utilized in performing the tests documented herein, has been calibrated in accordance with the manufacturer's recommendations for utilizing calibration equipment, which is traceable to recognized national standards.

2.3. TEST FACILITY

The SAC(Semi-Anechoic Chamber) and conducted measurement facility used to collect the radiated data are located at the 105-1, Jangam-ri , Majang-Myeon, Icheon-si, 467-811, KOREA.

The site is constructed in conformance with the requirements of ANSI C63.4 and CISPR Publication 22. Detailed description of test facility was submitted to the Commission and accepted dated March 02, 2011 (Registration Number: 90661)

FCC CERTIFICATION REPORT			www.hct.co.kr
Test Report No. HCTR1107FR12	Date of Issue: July 11, 2011	EUT Type: Modem	FCC ID: VA5GT1000

3. DESCRIPTION OF TESTS

3.1 EFFECTIVE RADIATED POWER/EQUIVALENT ISOTROPIC RADIATED POWER

Test Set-up

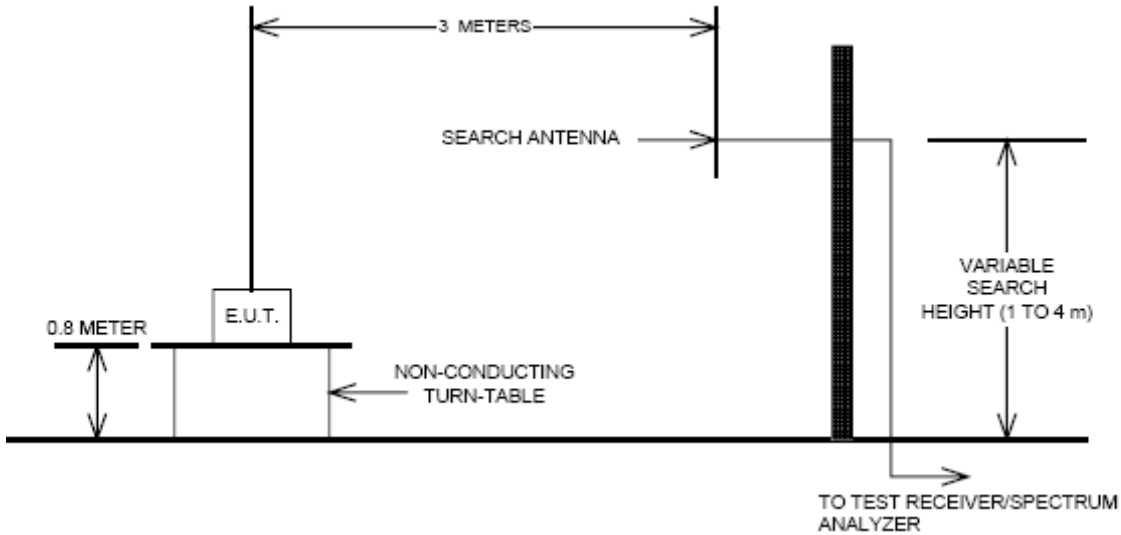

Test Procedure

Radiated emission measurements were performed at an SAC(Semi-Anechoic Chamber)

The equipment under test is placed on a non-conductive styrofoam resin table 3-meters from the receive antenna. A styrofoam turntable was rotated 360° and the receiving antenna scanned from 1-4m in order to capture the maximum emission. A half wave dipole was substituted in place of the EUT. This dipole antenna was driven by a signal generator and the previously recorded signal was duplicated.

The maximum EIRP was calculated by adding the forward power to the calibrated source plus its appropriate gain value. These steps were carried out with the receiving antenna in both vertical and horizontal polarization. For readings above 1GHz, the above procedure is repeated using horn antennas and the difference between the gain of the horn and an isotropic antenna are taken into consideration.

FCC CERTIFICATION REPORT			www.hct.co.kr
Test Report No. HCTR1107FR12	Date of Issue: July 11, 2011	EUT Type: Modem	FCC ID: VA5GT1000



3.2 PEAK- TO- AVERAGE RATIO

A peak to average ratio measurement is performed at the conducted port of the EUT. For CDMA and WCDMA signals, the spectrum analyzers Complementary Cumulative Distribution Function (CCDF) measurement profile is used to determine the largest deviation between the average and the peak power of the EUT in a given bandwidth. The CCDF curve shows how much time the peak waveform spends at or above a given average power level. The percent of time the signal spends at or above the level defines the probability for that particular power level. For GSM signals, an average and a peak trace are used on a

spectrum analyzer to determine the largest deviation between the average and the peak power of the EUT in a bandwidth greater than the emission bandwidth. Plots of the EUT's Peak- to- Average Ratio are shown herein.

FCC CERTIFICATION REPORT			www.hct.co.kr
Test Report No. HCTR1107FR12	Date of Issue: July 11, 2011	EUT Type: Modem	FCC ID: VA5GT1000

3.3 OCCUPIED BANDWIDTH.

Test set-up

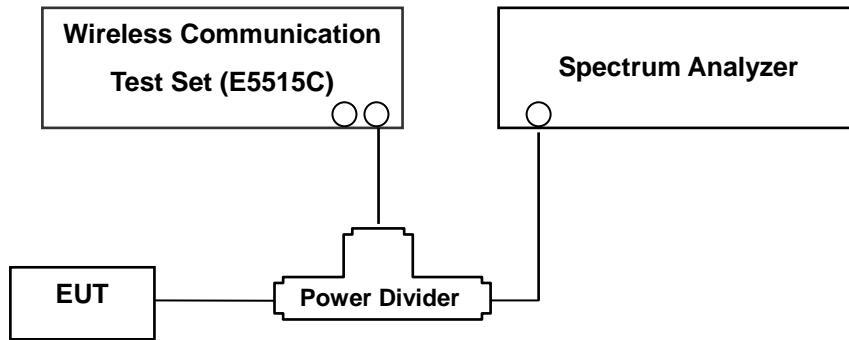

(Configuration of conducted Emission measurement)

Test Procedure

The EUT was setup to maximum output power at its lowest channel. The occupied bandwidth was measured using a spectrum analyzer. The measurements are repeated for the highest and a middle channel. The EUT's occupied bandwidth is measured as the width of the signal between two points, one below the carrier center frequency and one above the carrier frequency, outside of which all emissions are attenuated at least 26 dB below the transmitter power. Plots of the EUT's occupied bandwidth are shown herein.

FCC CERTIFICATION REPORT			www.hct.co.kr
Test Report No. HCTR1107FR12	Date of Issue: July 11, 2011	EUT Type: Modem	FCC ID: VA5GT1000

3.4 SPURIOUS AND HARMONIC EMISSIONS AT ANTENNA TERMINAL.

Test Procedure

The level of the carrier and the various conducted spurious and harmonic frequencies is measured by means of a calibrated spectrum analyzer.

The EUT was setup to maximum output power at its lowest channel. The Resolution BW of the analyzer is set to 1 % of the emission bandwidth to show compliance with the – 13 dBm limit, in the 1 MHz bands immediately outside and adjacent to the edge of the frequency block. The 1 MHz RBW was used to scan from 10 MHz to 10 GHz. (GSM1900 Mode: 10 MHz to 20 GHz). A display line was placed at – 13 dBm to show compliance. The high, lowest and a middle channel were tested for out of band measurements.

- Band Edge Requirement : In the 1MHz bands immediately outside and adjacent to the frequency block, a resolution bandwidth of at least 1 percent of the emission bandwidth of the fundamental emission of the transmitter may be employed to measure the out of band Emissions. Limit, -13dBm.

FCC CERTIFICATION REPORT			www.hct.co.kr
Test Report No. HCTR1107FR12	Date of Issue: July 11, 2011	EUT Type: Modem	FCC ID: VA5GT1000

3.5 RADIATED SPURIOUS AND HARMONIC EMISSIONS

Test Set-up

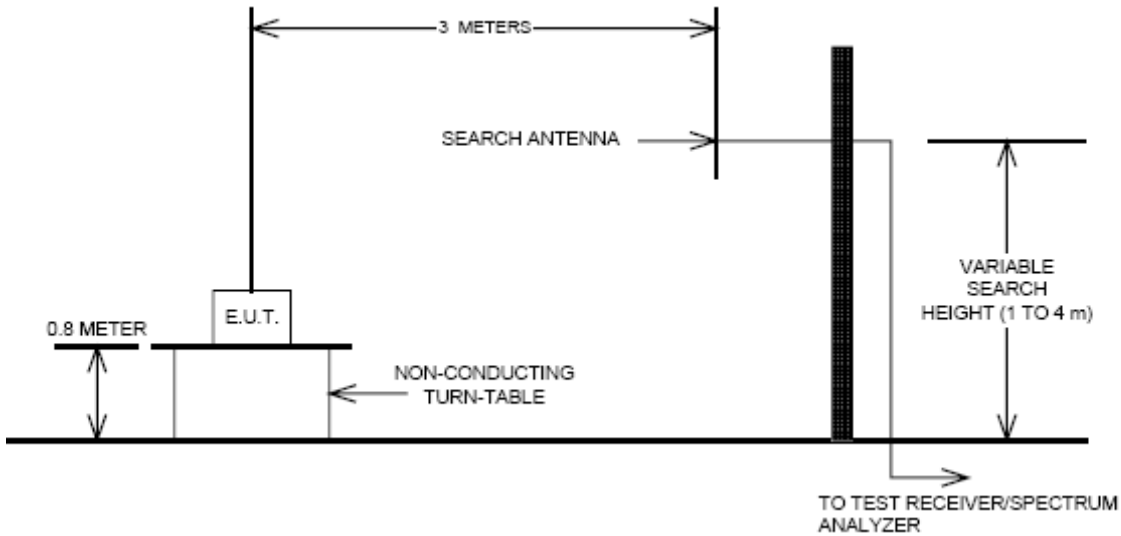

The measurement facilities used for this test have been documented in previous filings with the commission pursuant to section § 2.948. The SAC(Semi-Anechoic Chamber) meets requirements in ANSI C63.4 –2003. A mast capable of lifting the receiving antenna from a height of one to four meters is used together with a rotatable styrofoam platform mounted at three from the antenna mast.

- 1) The unit mounted on a styrofoam turntable 1.5 m × 1.0 m × 0.80 m is 0.8 meter above test site ground level.
- 2) During the emission test, the turntable is rotated and the EUT is manipulated to find the configuration resulting in maximum emission under normal condition of installation and operation.
- 3) The antenna height and polarization are also varied from 1 to 4 meters until the maximum signal is found.
- 4) The spectrum shall be scanned up to the 10th harmonic of the fundamental frequency.

Test Procedure

The equipment under test is placed on a non-conductive styrofoam resin table 3-meters from the receive antenna. A styrofoam turntable was rotated 360° and the receiving antenna scanned from 1-4m in order to capture the maximum emission. A half wave dipole was substituted in place of the EUT. This dipole antenna was driven by a signal generator and the previously recorded signal was duplicated.

The maximum EIRP was calculated by adding the forward power to the calibrated source plus its appropriate gain value. These steps were carried out with the receiving antenna in both vertical and horizontal polarization. For readings above 1GHz, the above procedure is repeated using horn antennas and the difference between the gain of the horn and an isotropic antenna are taken into consideration.

FCC CERTIFICATION REPORT			www.hct.co.kr
Test Report No. HCTR1107FR12	Date of Issue: July 11, 2011	EUT Type: Modem	FCC ID: VA5GT1000

3.6 FREQUENCY STABILITY / VARIATION OF AMBIENT TEMPERATURE

Test Set-up

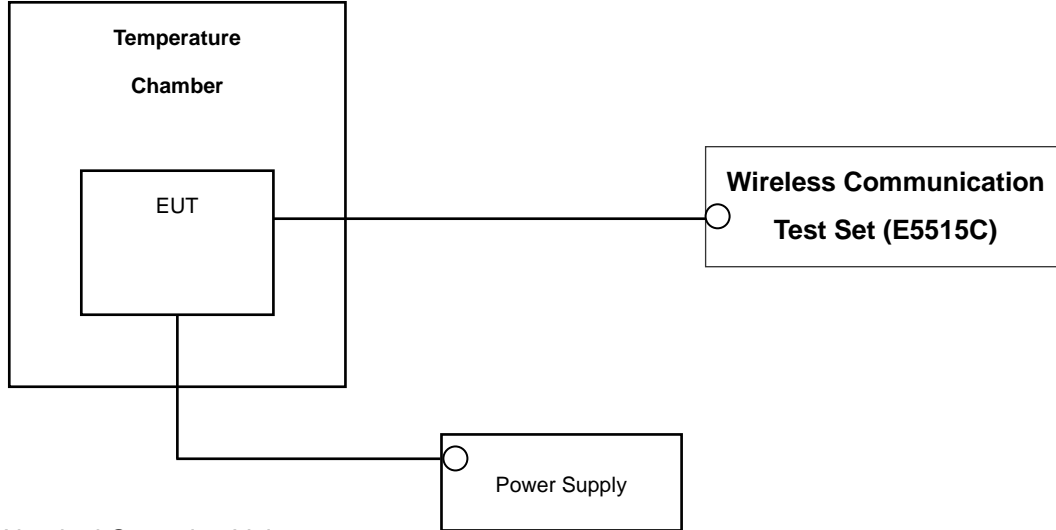

* Nominal Operating Voltage

Test Procedure

The frequency stability of the transmitter is measured by:

- a.) **Temperature:** The temperature is varied from - 30 °C to + 50 °C using an environmental chamber.
- b.) **Primary Supply Voltage:** The primary supply voltage is varied from battery end point to 115 % of the voltage normally at the input to the device or at the power supply terminals if cables are not normally supplied.

Specification — the frequency stability shall be sufficient to ensure that the fundamental emission stays within the authorized frequency block. The frequency stability of the transmitter shall be maintained within $\pm 0.00025\%$ (± 2.5 ppm) of the center frequency.

Time Period and Procedure:

The carrier frequency of the transmitter is measured at room temperature (20°C to provide a reference).

1. The equipment is turned on in a “standby” condition for one minute before applying power to the transmitter. Measurement of the carrier frequency of the transmitter is made within one minute after applying power to the transmitter.
2. Frequency measurements are made at 10°C intervals ranging from -30°C to +50°C. A period of at least one half-hour is provided to allow stabilization of the equipment at each temperature level.

NOTE: The EUT is tested down to the battery endpoint.

FCC CERTIFICATION REPORT			www.hct.co.kr
Test Report No. HCTR1107FR12	Date of Issue: July 11, 2011	EUT Type: Modem	FCC ID: VA5GT1000

4. LIST OF TEST EQUIPMENT

Manufacture	Model/ Equipment	Serial Number	Calibration Interval	Calibration Due
R&S	N9020A	MY51110020	Annual	04/16/2012
Agilent	E4416A/ Power Meter	GB41291412	Annual	01/04/2012
Agilent	E9327A/ Power Sensor	MY4442009	Annual	05/02/2012
Agilent	8960 (E5515C)/ Base Station	GB44400269	Annual	02/10/2012
MITEQ	AMF-6D-001180-35-20P/AMP	990893	Annual	05/02/2012
Wainwright	WHK1.2/15G-10EF/H.P.F	2	Annual	05/02/2012
Wainwright	WHK3.3/18G-10EF/H.P.F	1	Annual	05/02/2012
Agilent	775D/ Dual Directional Coupler	12922	Annual	12/29/2011
Agilent	11636B/ Power Divider	11377	Annual	12/29/2011
Digital	EP-3010/ Power Supply	3110117	Annual	01/04/2012
Schwarzbeck	UHAP/ Dipole Antenna	949	Biennial	03/18/2012
Schwarzbeck	UHAP/ Dipole Antenna	950	Biennial	03/18/2012
Korea Engineering	KR-1005L / Chamber	KRAB07063-2CH	Annual	12/28/2011
Schwarzbeck	BBHA 9120D/ Horn Antenna	296	Biennial	09/23/2011
Schwarzbeck	BBHA 9120D/ Horn Antenna	147	Biennial	04/13/2012
Agilent	E4440A/Spectrum Analyzer	US45303008	Annual	05/02/2012

5. SUMMARY OF TEST RESULTS

FCC Part Section(s)	Test Description	Test Limit	Test Condition	Test Result
2.1049, 22.917(a), 24.238(a)	Occupied Bandwidth	N/A	CONDUCTED	PASS
2.1051, 22.917(a), 24.238(a)	Band Edge / Spurious and Harmonic Emissions at Antenna Terminal.	< 43 + 10log10 (P[Watts]) at Band Edge and for all out-of-band emissions		PASS
2.1046	Conducted Output Power	-		PASS
24.232(d)	Peak- to- Average Ratio	< 13 dB		PASS
2.1055, 22.355, 24.235	Frequency stability / variation of ambient temperature	< 2.5 ppm		PASS
22.913(a)(2) 24.232(c)	Effective Radiated Power	< 7 Watts max. ERP	RADIATED	PASS
	Equivalent Isotropic Radiated Power	< 2 Watts max. EIRP		PASS
2.1053, 22.917(a), 24.238(a)	Radiated Spurious and Harmonic Emissions	< 43 + 10log10 (P[Watts]) for all out-of band emissions		PASS

6. SAMPLE CALCULATION

A. ERP Sample Calculation

Mode	Ch./ Freq.		Measured	Substitute	Ant. Gain	C.L	Pol.	ERP	
	channel	Freq.(MHz)	Level(dBm)	LEVEL(dBm)				W	dBm
GSM850	128	824.20	-11.56	34.28	-8.32	1.17	H	0.30	24.79

ERP = SubstituteLEVEL(dBm) + Ant. Gain – CL(Cable Loss)

- 1) The EUT mounted on a wooden tripod is 0.8 meter above test site ground level.
- 2) During the test , the turn table is rotated and the antenna height is also varied from 1 to 4 meters until the maximum signal is found.
- 3) Record the field strength meter's level.
- 4) Replace the EUT with dipole/Horn antenna that is connected to a calibrated signal generator.
- 5) Increase the signal generator output till the field strength meter's level is equal to the item (3).
- 6) The signal generator output level with Ant. Gain and cable loss are the rating of effective radiated power (ERP).

B. Emission Designator

GSM Emission Designator

Emission Designator = 249KGXW

GSM BW = 249 kHz

G = Phase Modulation

X = Cases not otherwise covered

W = Combination (Audio/Data)

WCDMA Emission Designator

Emission Designator = 4M17F9W

WCDMA BW = 4.17 MHz

F = Frequency Modulation

9 = Composite Digital Info

W = Combination (Audio/Data)

FCC CERTIFICATION REPORT			www.hct.co.kr
Test Report No. HCTR1107FR12	Date of Issue: July 11, 2011	EUT Type: Modem	FCC ID: VA5GT1000

7. TEST DATA

7.1 CONDUCTED OUTPUT POWER

A base station simulator was used to establish communication with the EUT. The base station simulator parameters were set to produce the maximum power from the EUT. This device was tested under all configurations and the highest power is reported. Conducted Output Powers of EUT are reported below.

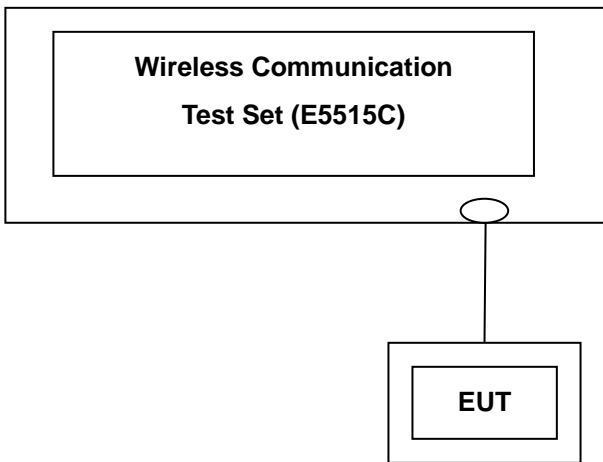

Test Result

Band	Channel	GPRS Data	
		GPRS 1 TX Slot (dBm)	GPRS 2 TX Slot (dBm)
GSM 850	128	31.45	29.71
	190	31.61	29.89
	251	31.32	29.59
GSM 1900	512	28.07	26.43
	661	28.01	26.40
	810	28.22	26.59

(GSM Conducted Maximum Output Powers)

7.2 PEAK-TO-AVERAGE RATIO

- Plots of the EUT's Peak- to- Average Ratio are shown Page 28.

7.3 OCCUPIED BANDWIDTH

Band	Channel	Frequency(MHz)	Data (GSM: kHz / WCDMA : MHz)
GSM850	128	824.20	249.8539
	190	836.60	248.7664
	251	848.80	247.2376
GSM1900	512	1850.20	244.1078
	661	1880.00	242.0280
	810	1909.80	241.2726

- Plots of the EUT's Occupied Bandwidth are shown Page 25 ~ 27.

7.4 CONDUCTED SPURIOUS EMISSIONS

Band	Channel	Frequency of Maximum Harmonic (GHz)	Maximum Data (dBm)
GSM850	128	7.1125	-30.32
	190	7.3875	-30.06
	251	7.0750	-31.37
GSM1900	512	14.3200	-27.67
	661	13.6530	-27.61
	810	13.7330	-28.31

- Plots of the EUT's Conducted Spurious Emissions are shown Page 32 ~ 38.

7.4.1 BAND EDGE

- Plots of the EUT's Band Edge are shown Page 28 ~ 32.

7.5 EFFECTIVE RADIATED POWER OUTPUT (GSM)

(GSM850 Mode)

Ch./ Freq.		Measured Level(dBm)	Substitute LEVEL (dBm)	Ant. Gain (dBd)	C.L	Pol.	ERP	
channel	Freq.(MHz)						W	dBm
128	824.20	-7.55	41.38	-10.54	1.61	V	0.84	29.23
190	836.60	-5.77	43.15	-10.50	1.67	V	1.25	30.98
251	848.80	-6.45	42.61	-10.47	1.64	V	1.12	30.50

Note: Standard batteries are the only options for this phone

NOTES:

Effective Radiated Power Output Measurements by Substitution Method

according to ANSI/TIA/EIA-603-C-2004, Aug. 17, 2004:

The EUT was placed on a non-conductive styrofoam resin table 3-meters from the receive antenna. The receive antenna height and turntable rotation was adjusted for the highest reading on the receive spectrum analyzer. For CDMA signals, a peak detector is used, with RBW = VBW = 3 MHz. For WCDMA signals, a peak detector is used, with RBW = VBW = 5MHz. For AMPS, GSM, and NADC TDMA signals, a peak detector is used, with RBW = VBW = 1 MHz. A half-wave dipole was substituted in place of the EUT. This dipole antenna was driven by a signal generator and the level of the signal generator was adjusted to obtain the same receive spectrum analyzer reading. The conducted power at the terminals of the dipole is measured. The ERP is recorded.

This device was tested under all configurations and the highest power is reported in WCDMA mode with HSDPA Inactive at 12.2 kbps RMC and TPC bits all set to "1" and in GSM mode and using a Power Control Level of "0" in the PCS Band and "5" in the Cellular Band. This unit was tested with its standard battery. Also, we have done x, y, z planes in EUT and horizontal and vertical polarization in detecting antenna. The worst case of the EUT is z plane in GSM850 mode. Also worst case of detecting Antenna is vertical polarization in GSM850 mode.

FCC CERTIFICATION REPORT			www.hct.co.kr
Test Report No. HCTR1107FR12	Date of Issue: July 11, 2011	EUT Type: Modem	FCC ID: VA5GT1000

7.6 EQUIVALENT ISOTROPIC RADIATED POWER (GSM)

(GSM1900 Mode)

Ch./ Freq.		Measured Level(dBm)	Substitute LEVEL (dBm)	Ant. Gain (dBi)	C.L	Pol.	EIRP	
channel	Freq.(MHz)						W	dBm
512	1,850.20	-9.82	23.89	10.40	2.83	H	1.40	31.45
661	1,880.00	-10.19	23.59	10.43	2.81	H	1.32	31.21
810	1,909.80	-10.45	23.54	10.47	2.86	H	1.30	31.15

Note: Standard batteries are the only options for this phone

NOTES:

Equivalent Isotropic Radiated Power Measurements by Substitution Method

according to ANSI/TIA/EIA-603-C-2004, Aug. 17, 2004:

The EUT was placed on a non-conductive styrofoam resin table 3-meters from the receive antenna. The receive antenna height and turntable rotation was adjusted for the highest reading on the receive spectrum analyzer. For CDMA signals, a peak detector is used, with RBW = VBW = 3 MHz. For WCDMA signals, a peak detector is used, with RBW = VBW = 5MHz. For AMPS, GSM, and NADC TDMA signals, a peak detector is used, with RBW = VBW = 1 MHz. A Horn antenna was substituted in place of the EUT. This Horn antenna was driven by a signal generator and the level of the signal generator was adjusted to obtain the same receive spectrum analyzer reading. The conducted power at the terminals of the Horn antenna is measured. The difference between the gain of the horn and an isotropic antenna is taken into consideration and the EIRP is recorded.

This device was tested under all configurations and the highest power is reported in WCDMA mode with HSDPA Inactive at 12.2 kbps RMC and TPC bits all set to "1" and in GSM mode and using a Power Control Level of "0" in the PCS Band and "5" in the Cellular Band. This unit was tested with its standard battery. Also, we have done x, y, z planes in EUT and horizontal and vertical polarization in detecting antenna. The worst case of the EUT is x plane in GSM1900 mode. Also worst case of detecting Antenna is in horizontal polarization in GSM1900 mode.

FCC CERTIFICATION REPORT			www.hct.co.kr
Test Report No. HCTR1107FR12	Date of Issue: July 11, 2011	EUT Type: Modem	FCC ID: VA5GT1000

7.7 RADIATED SPURIOUS EMISSIONS

7.7.1 RADIATED SPURIOUS EMISSIONS (GSM850)

- MEASURED OUTPUT POWER: 30.98 dBm = 1.253W
- MODULATION SIGNAL: GSM850
- DISTANCE: 3 meters
- LIMIT: $-(43 + 10 \log_{10}(W)) =$ - 43.98 dBc

Ch.	Freq.(MHz)	Measured Level [dBm]	Ant. Gain (dBd)	Substitute Level [dBm]	C.L	Pol.	ERP (dBm)	dBc
128 (824.2)	1,648.40	-47.21	9.66	-57.54	2.63	H	-50.51	-81.49
	2,472.60	-43.37	10.79	-51.21	3.55	H	-43.97	-74.95
	3,296.80	-	-	-	-	-	-	-
190 (836.6)	1,673.20	-34.70	9.77	-45.10	2.67	H	-38.00	-68.98
	2,509.80	-46.88	10.82	-54.79	3.61	H	-47.58	-78.56
	3,346.40	-	-	-	-	-	-	-
251 (848.8)	1,697.60	-31.39	9.94	-42.22	2.61	V	-34.89	-65.87
	2,546.40	-49.10	10.84	-57.44	3.60	H	-50.20	-81.18
	3,395.20	-	-	-	-	-	-	-

- NOTES:**
1. Radiated Spurious Emission Measurements at 3 meters by Substitution Method according to ANSI/TIA/EIA-603-C-2004, Aug. 17, 2004:
 2. The magnitude of spurious emissions attenuated more than 20dB below the limit above 5th Harmonic for all channel.
 3. we have done x, y, z planes in EUT and horizontal and vertical polarization in detecting antenna.

7.7.2 RADIATED SPURIOUS EMISSIONS (GSM1900)

- MEASURED OUTPUT POWER: 31.45 dBm = 1.396 W
- MODULATION SIGNAL: GSM1900
- DISTANCE: 3 meters
- LIMIT: - (43 + 10 log₁₀ (W)) = - 44.45 dBc

Ch.	Freq.(MHz)	Measured Level [dBm]	Ant. Gain (dBi)	Substitute Level [dBm]	C.L	Pol.	EIRP (dBm)	dBc
512 (1850.2)	3,700.40	-53.22	12.36	-60.01	4.87	H	-52.52	-83.97
	5,550.60	-52.03	12.61	-53.08	6.66	V	-47.13	-78.58
	7,400.80	-	-	-	-	-	-	-
661 (1880.0)	3,760.00	-53.38	12.40	-60.10	4.88	H	-52.58	-84.03
	5,640.00	-50.54	12.65	-51.85	6.54	H	-45.74	-77.19
	7,520.00	-56.74	10.84	-48.46	7.32	V	-44.94	-76.39
810 (1909.8)	3,819.60	-53.34	12.45	-59.57	5.02	H	-52.14	-83.59
	5,729.40	-49.09	12.71	-50.46	6.54	V	-44.29	-75.74
	7,639.20	-	-	-	-	-	-	-

- NOTES:**
1. Radiated Spurious Emission Measurements at 3 meters by Substitution Method according to ANSI/TIA/EIA-603-C-2004, Aug. 17, 2004:
 2. The magnitude of spurious emissions attenuated more than 20dB below the limit above 5th Harmonic for all channel.
 3. we have done x, y, z planes in EUT and horizontal and vertical polarization in detecting antenna.

7.8 FREQUENCY STABILITY / VARIATION OF AMBIENT TEMPERATURE

7.8.1 FREQUENCY STABILITY (GSM850)

OPERATING FREQUENCY: 836,600,000 Hz
 CHANNEL: 190
 REFERENCE VOLTAGE: 3.7 VDC
 DEVIATION LIMIT: ± 0.000 25 % or 2.5 ppm

Voltage (%)	Power (VDC)	Temp. (°C)	Frequency (Hz)	Frequency Error (Hz)	Deviation (%)	ppm
100%	3.700	+20(Ref)	836 600 017	0	0.000 000	0.000
100%		-30	836 599 977	-23.41	-0.000 003	-0.028
100%		-20	836 599 994	-5.58	-0.000 001	-0.007
100%		-10	836 600 003	2.89	0.000 000	0.003
100%		0	836 599 985	-15.36	-0.000 002	-0.018
100%		+10	836 599 998	-1.84	0.000 000	-0.002
100%		+30	836 600 003	2.87	0.000 000	0.003
100%		+40	836 599 983	-17.14	-0.000 002	-0.020
100%		+50	836 600 000	0.06	0.000 000	0.000
115%		4.255	+20	836 599 979	-21.27	-0.000 003
Batt. Endpoint	3.400	+20	836 600 004	4.42	0.000 001	0.005

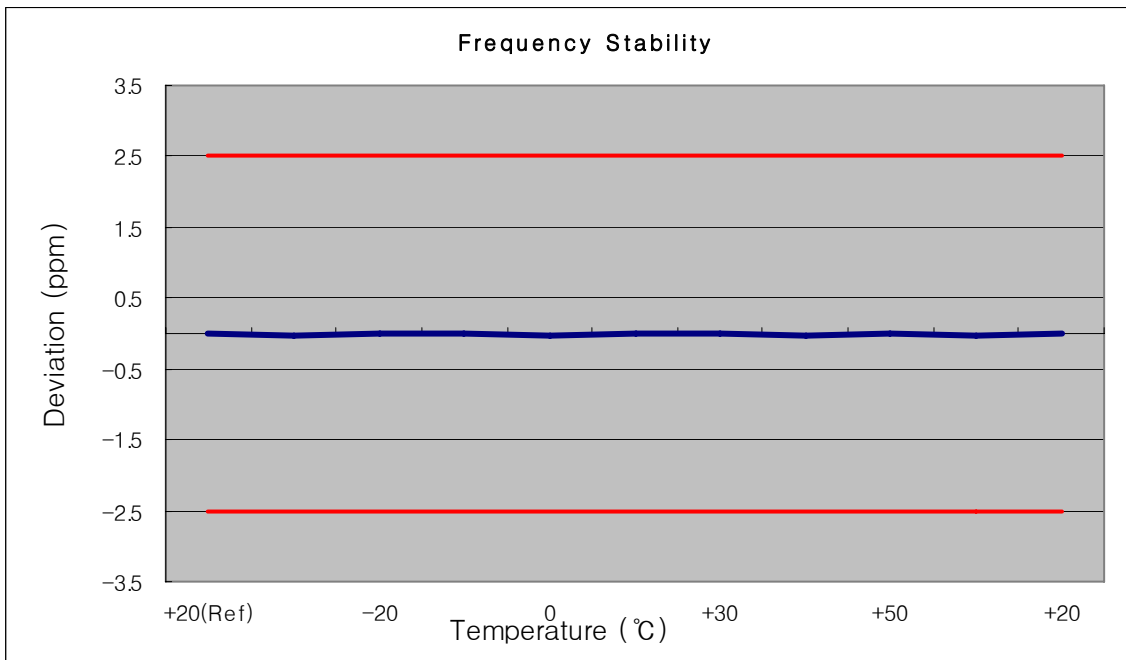

7.8.2 FREQUENCY STABILITY (GSM1900)

OPERATING FREQUENCY: 1880,000,000 Hz
 CHANNEL: 661
 REFERENCE VOLTAGE: 3.7 VDC
 DEVIATION LIM IT: ± 0.000 25 % or 2.5 ppm

Voltage (%)	Power (VDC)	Temp. (°C)	Frequency (Hz)	Frequency Error (Hz)	Deviation (%)	ppm
100%	3.700	+20(Ref)	1879 999 972	0	0.000 000	0.000
100%		-30	1879 999 986	-13.58	-0.000 001	-0.007
100%		-20	1879 999 993	-6.69	0.000 000	-0.004
100%		-10	1879 999 992	-8.50	0.000 000	-0.005
100%		0	1879 999 999	-1.43	0.000 000	-0.001
100%		+10	1880 000 025	25.18	0.000 001	0.013
100%		+30	1879 999 994	-5.84	0.000 000	-0.003
100%		+40	1879 999 982	-18.17	-0.000 001	-0.010
100%		+50	1879 999 990	-10.33	-0.000 001	-0.005
115%		4.255	+20	1880 000 030	30.46	0.000 002
Batt. Endpoint	3.400	+20	1880 000 036	35.79	0.000 002	0.019

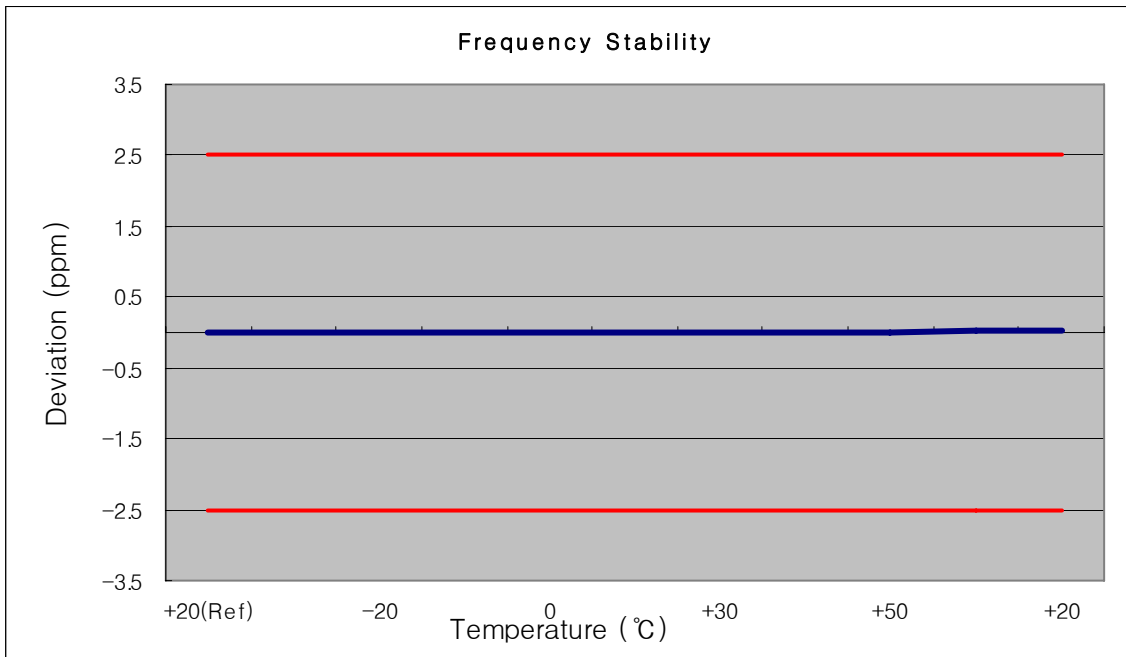



8. TEST PLOTS

FCC CERTIFICATION REPORT			www.hct.co.kr
Test Report No. HCTR1107FR12	Date of Issue: July 11, 2011	EUT Type: Modem	FCC ID: VA5GT1000

■ GSM850 MODE (128 CH.) Occupied Bandwidth

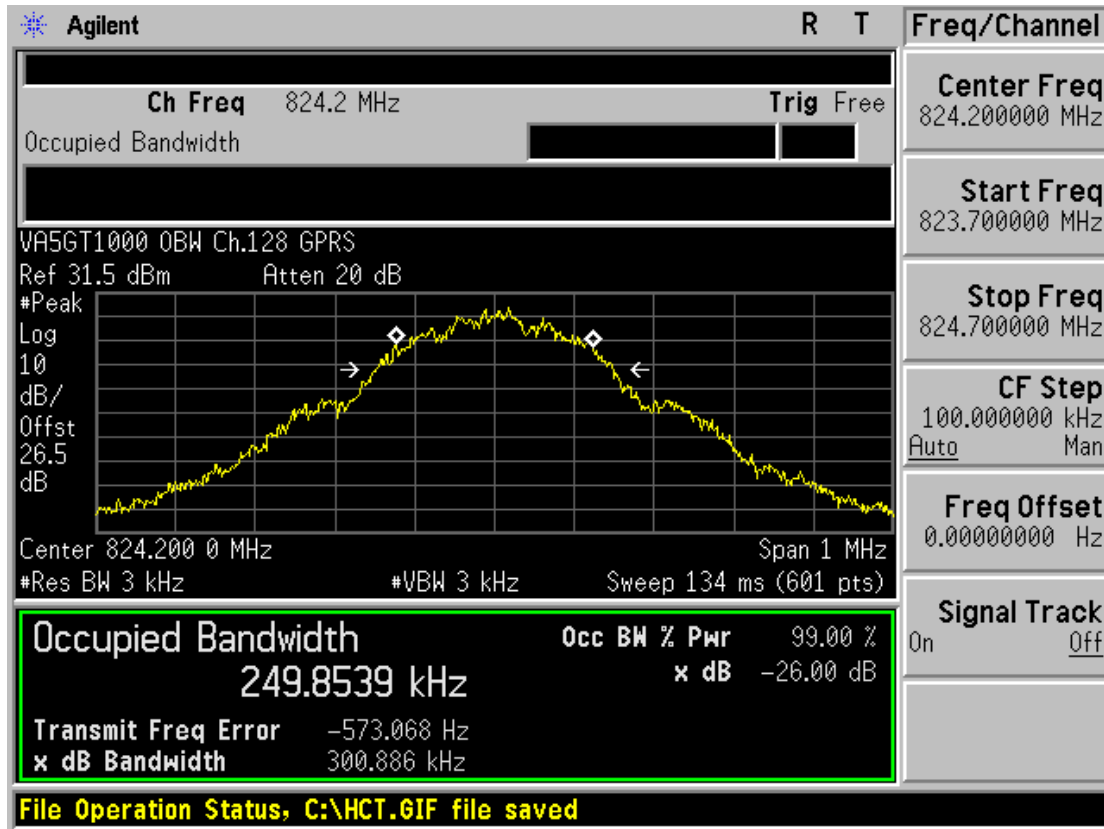

■ GSM850 MODE (190 CH.) Occupied Bandwidth

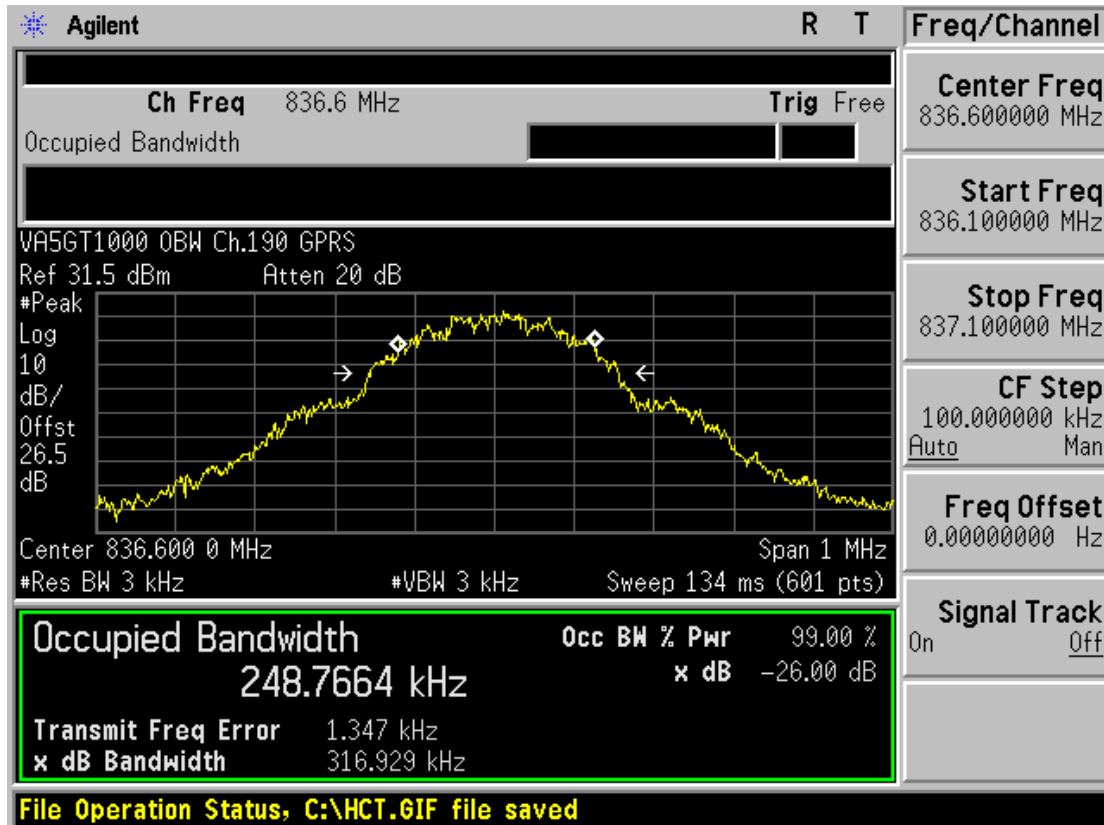

■ GSM850 MODE (251 CH.) Occupied Bandwidth

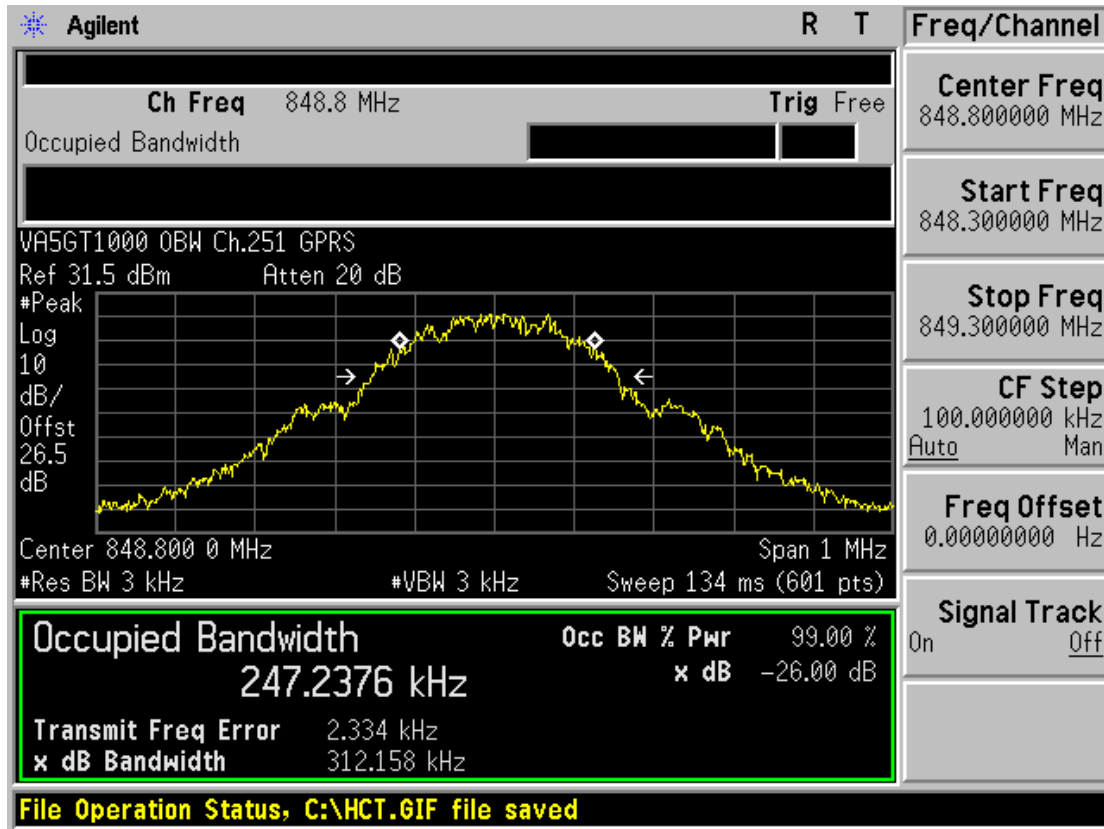

■ GSM1900 MODE (512 CH.) Occupied Bandwidth

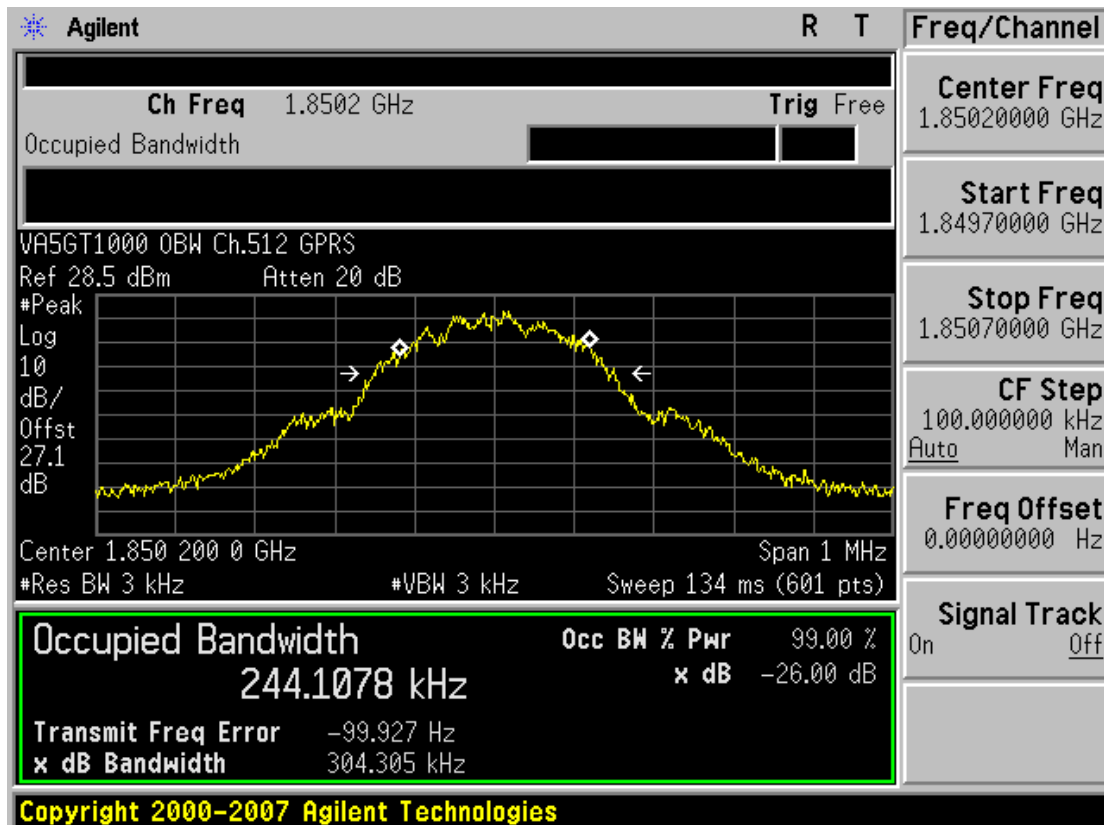

■ GSM1900 MODE (661 CH.) Occupied Bandwidth

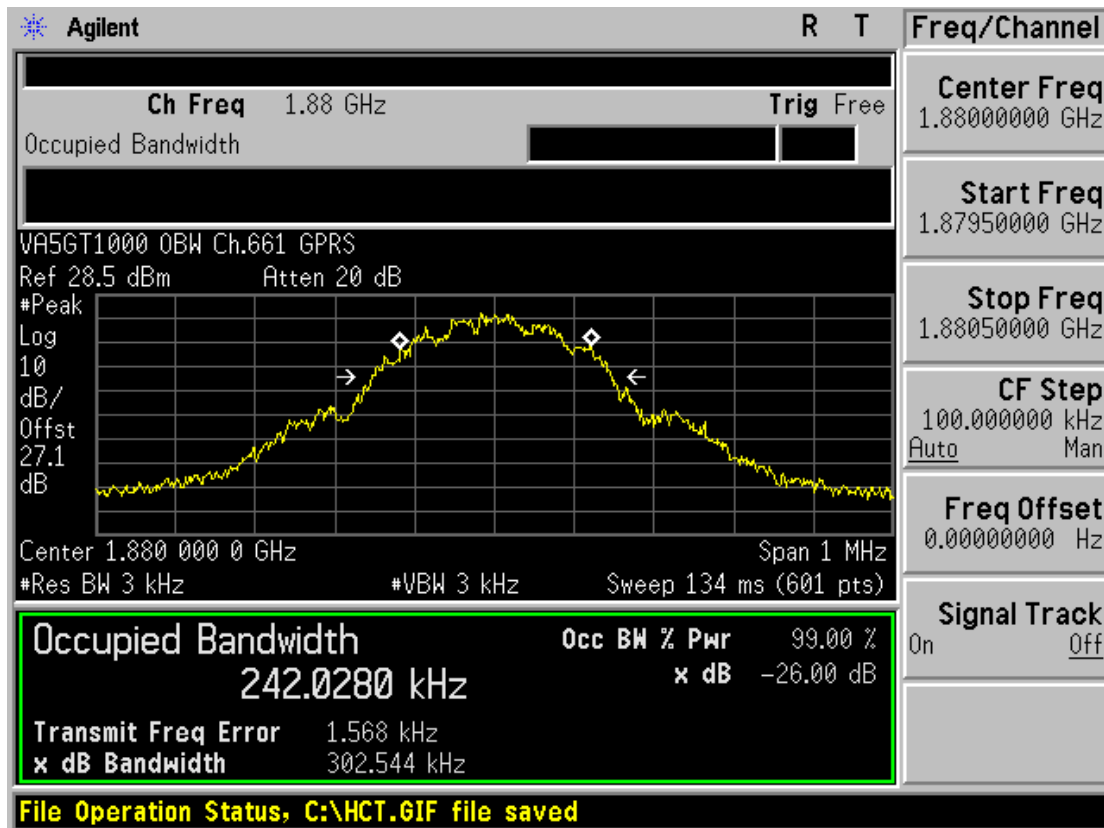

■ GSM1900 MODE (810 CH.) Occupied Bandwidth

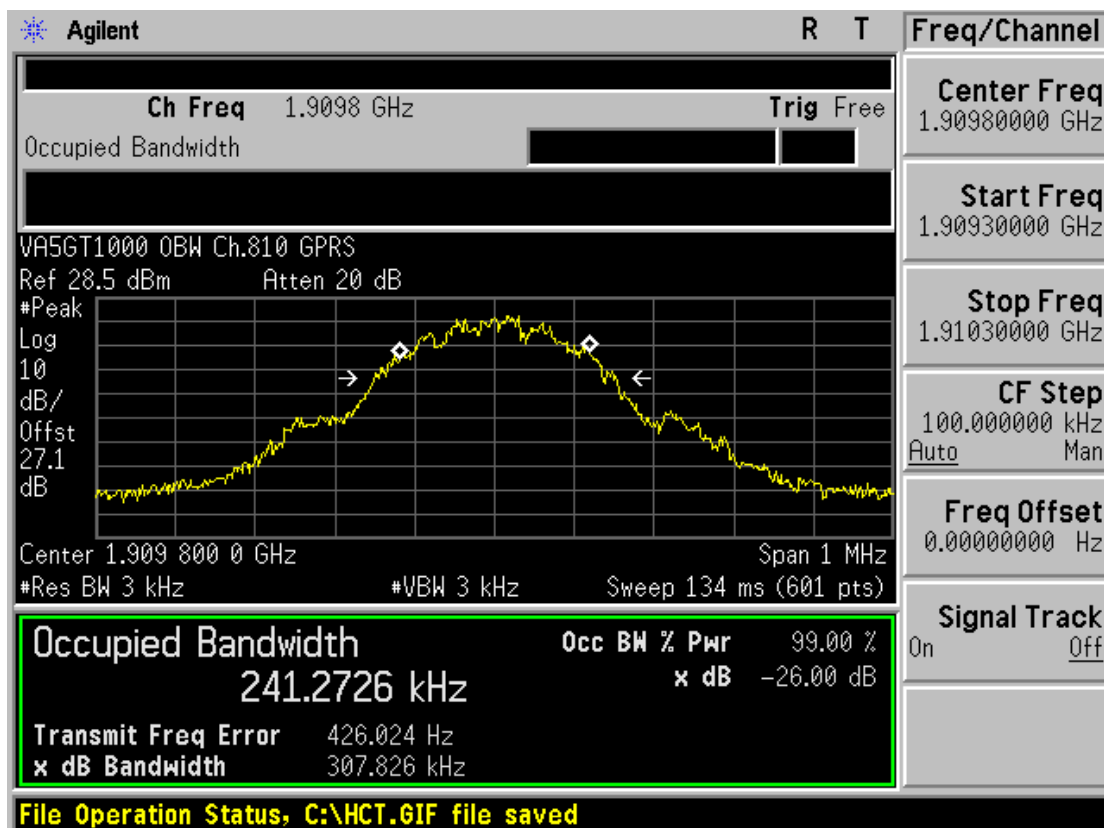

FCC CERTIFICATION REPORT

Test Report No. HCTR1107FR12	Date of Issue: July 11, 2011	EUT Type: Modem	www.hct.co.kr FCC ID: VA5GT1000
---------------------------------	---------------------------------	--------------------	--

■ GSM1900 MODE (661 CH.) Peak-to-Average Ratio

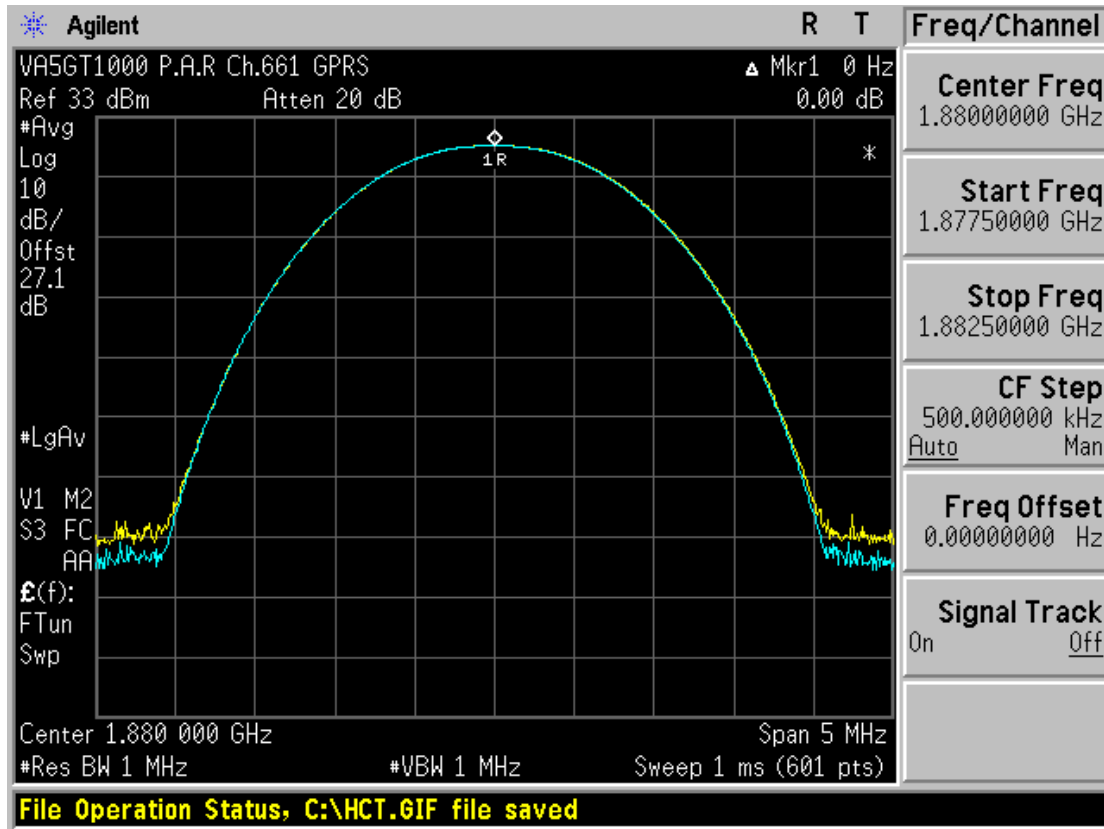

■ GSM850 MODE (128 CH.) Block Edge 1

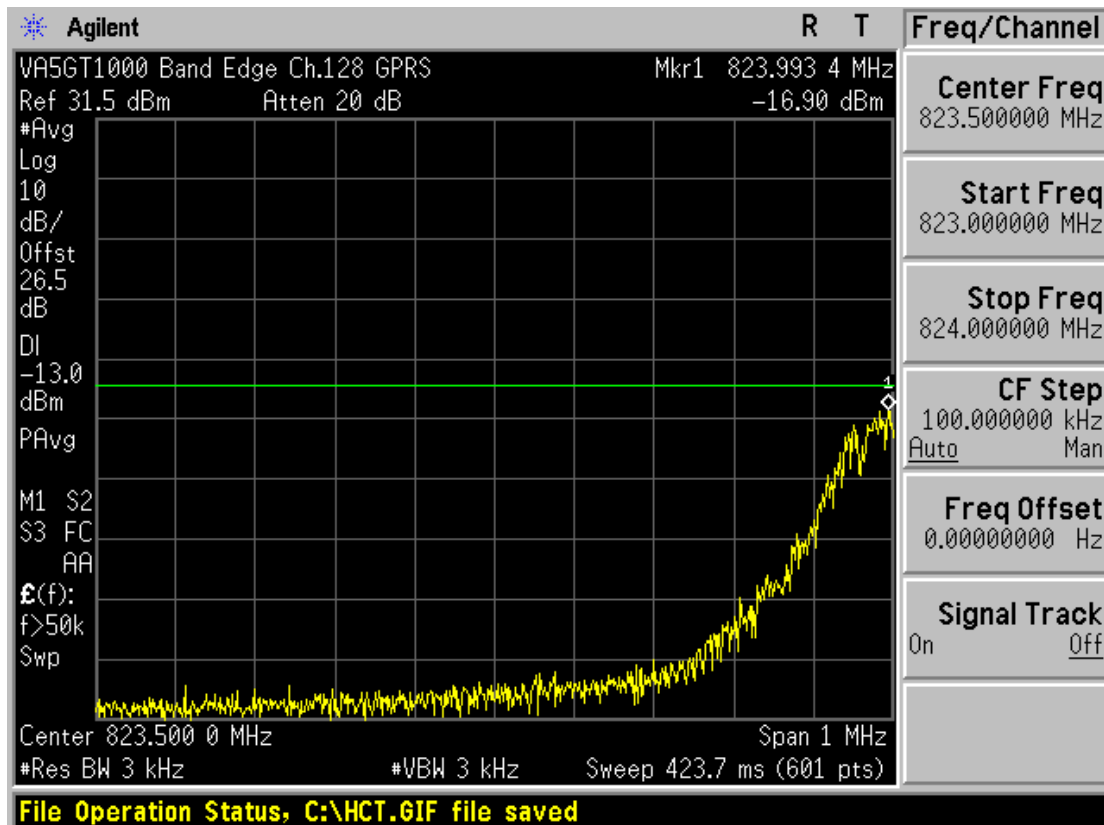

■ GSM850 MODE (128 CH.) Block Edge 2



■ GSM850 MODE (251 CH.) Block Edge 1

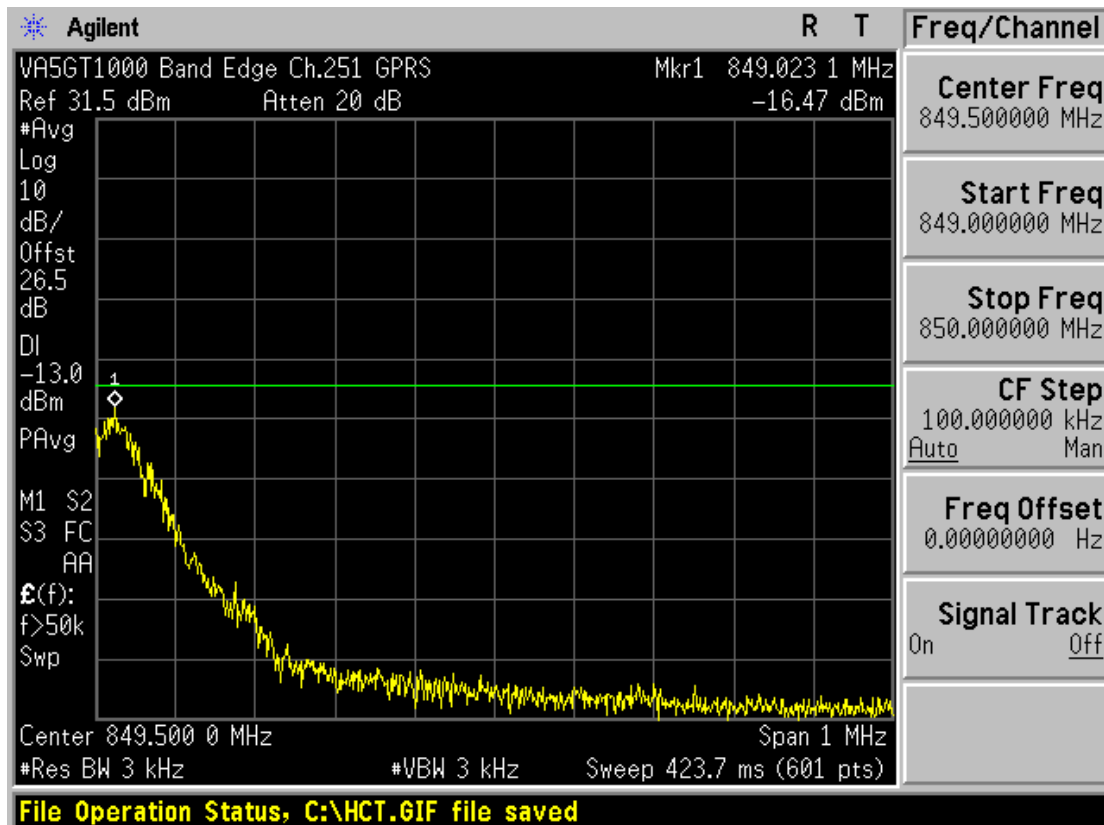

FCC CERTIFICATION REPORT			www.hct.co.kr
Test Report No. HCTR1107FR12	Date of Issue: July 11, 2011	EUT Type: Modem	FCC ID: VA5GT1000

■ GSM850 MODE (251 CH.) Block Edge 2

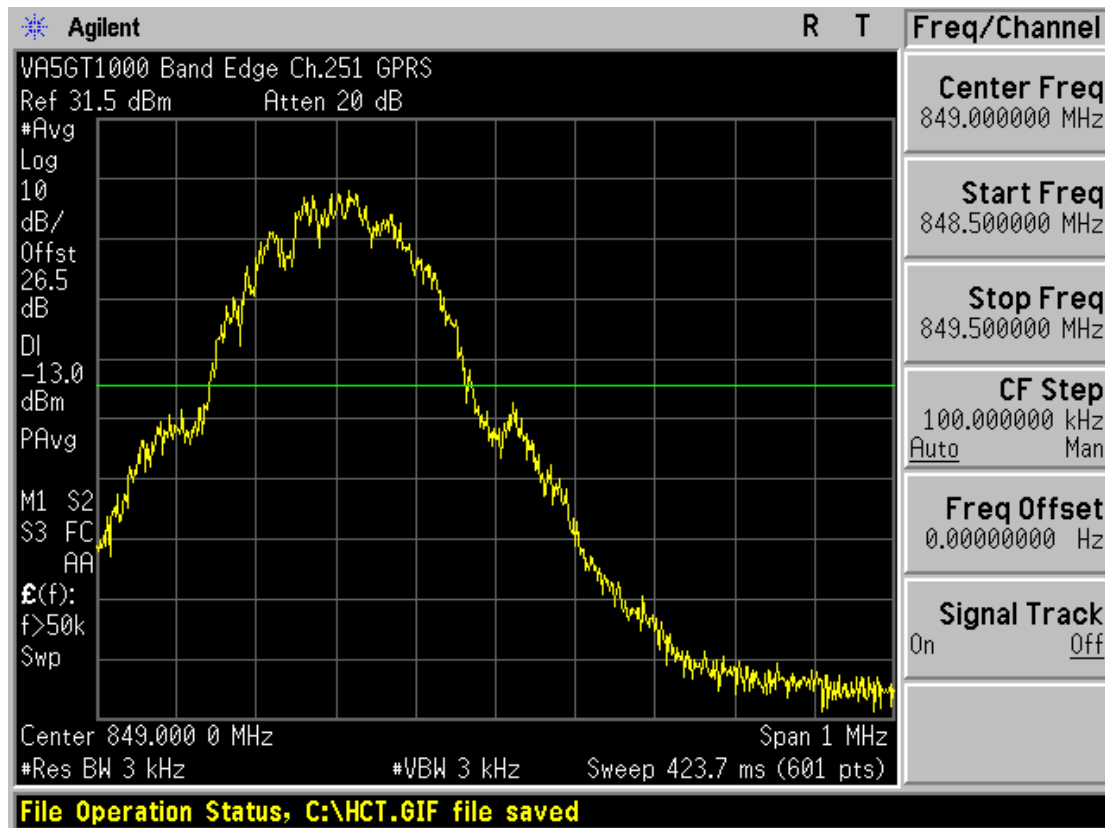

■ GSM1900 MODE (512 CH.) Block Edge 1

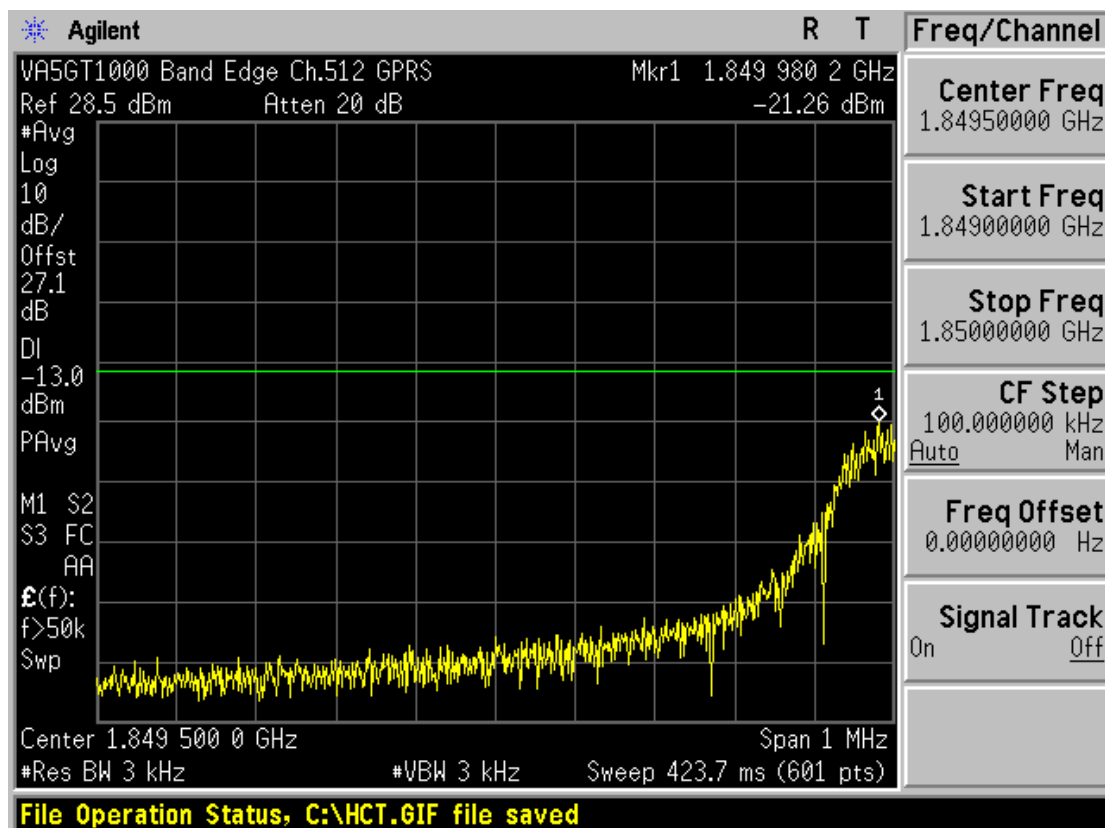

FCC CERTIFICATION REPORT			www.hct.co.kr
Test Report No. HCTR1107FR12	Date of Issue: July 11, 2011	EUT Type: Modem	FCC ID: VA5GT1000

■ GSM1900 MODE (512 CH.) Block Edge 2

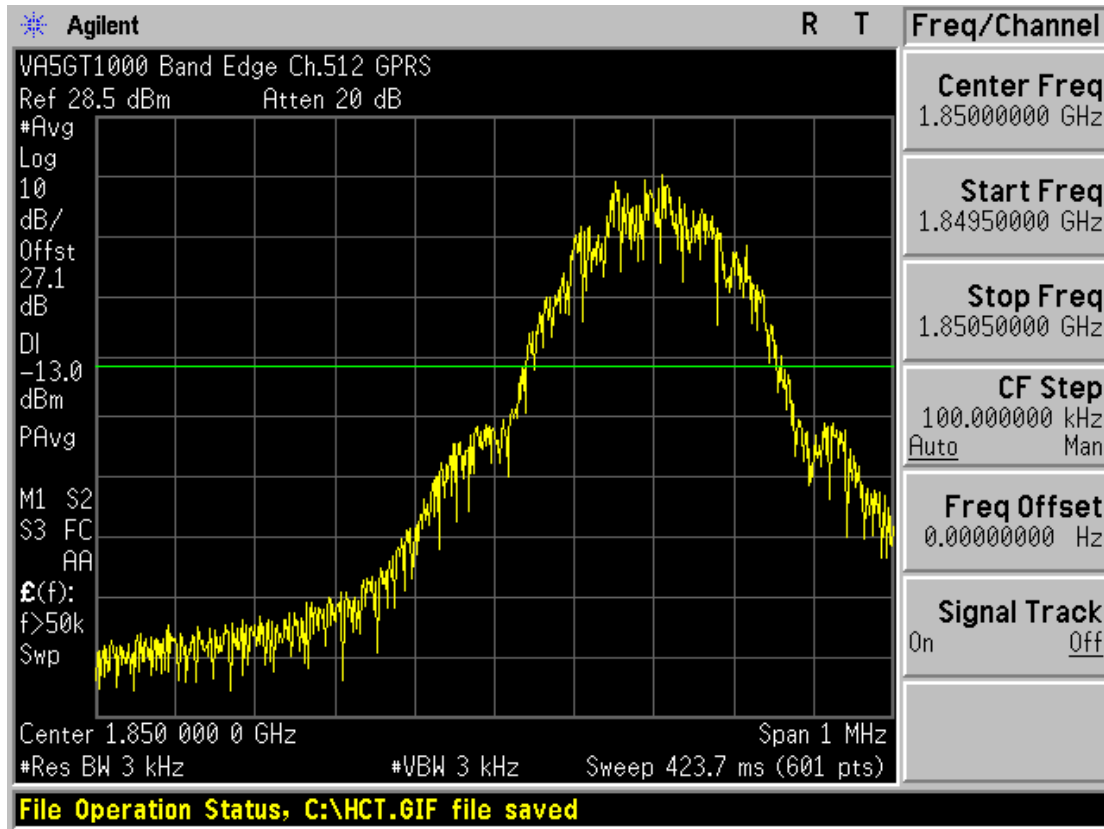

■ GSM1900 MODE (810 CH.) Block Edge 1

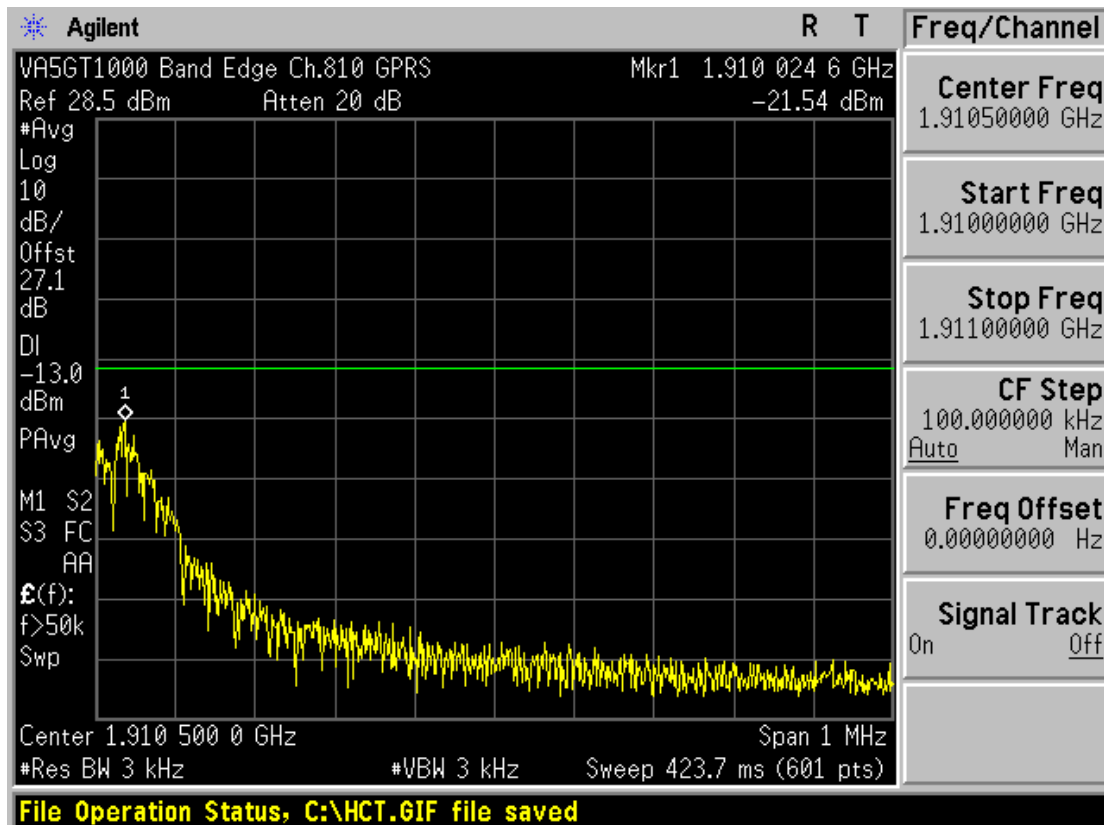

FCC CERTIFICATION REPORT			www.hct.co.kr
Test Report No. HCTR1107FR12	Date of Issue: July 11, 2011	EUT Type: Modem	FCC ID: VA5GT1000

■ GSM1900 MODE (810 CH.) Block Edge 2

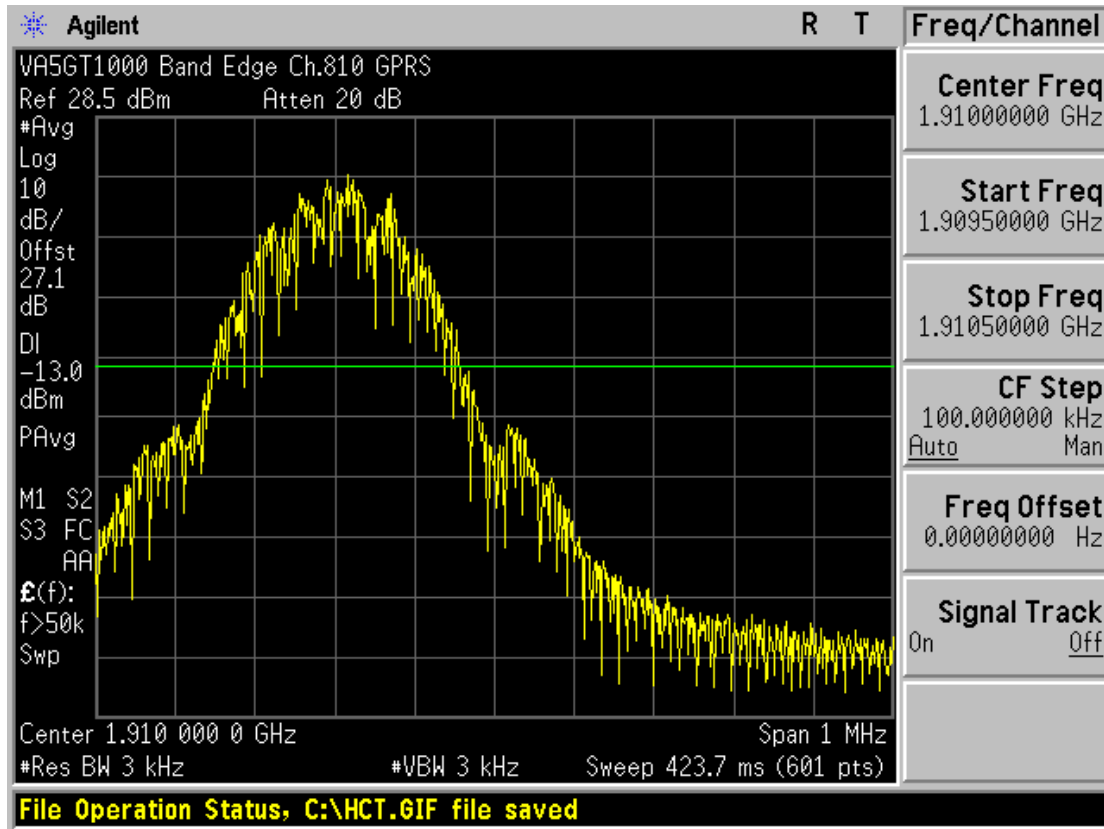

■ GSM850 MODE (128 CH.) Conducted Spurious Emissions1

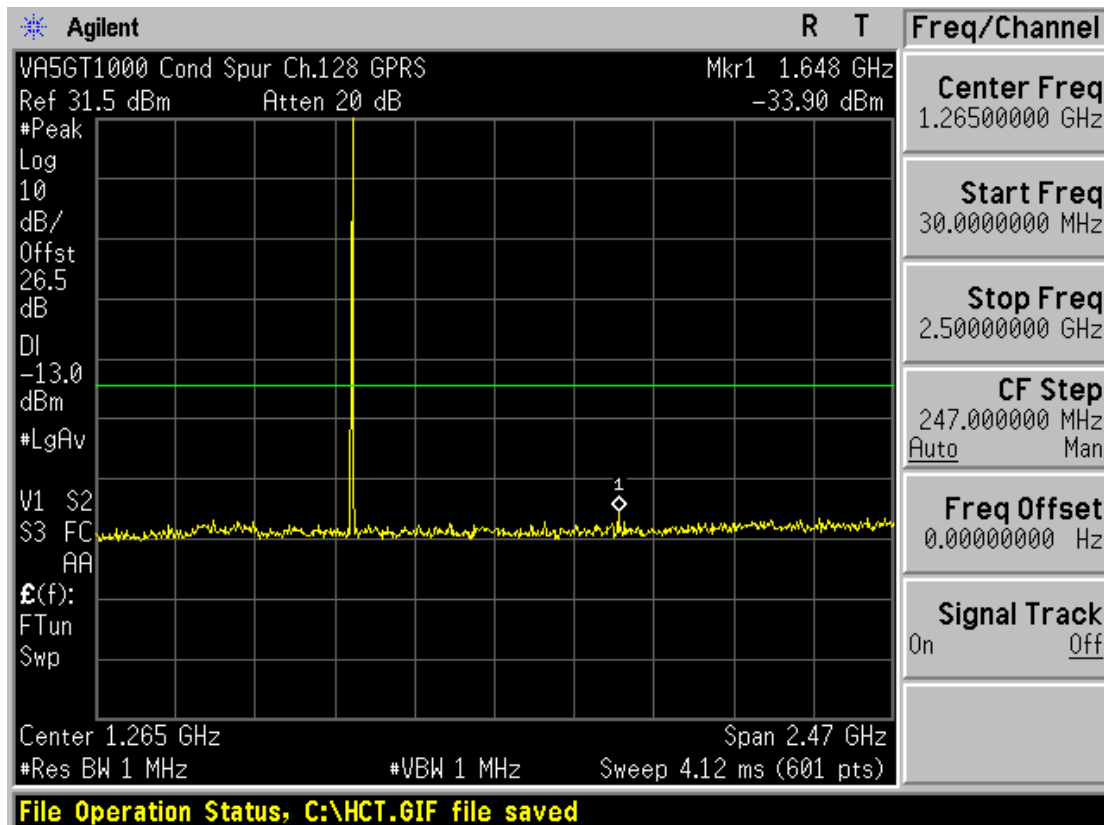

FCC CERTIFICATION REPORT			www.hct.co.kr
Test Report No. HCTR1107FR12	Date of Issue: July 11, 2011	EUT Type: Modem	FCC ID: VA5GT1000

■ GSM850 MODE (128 CH.) Conducted Spurious Emissions2

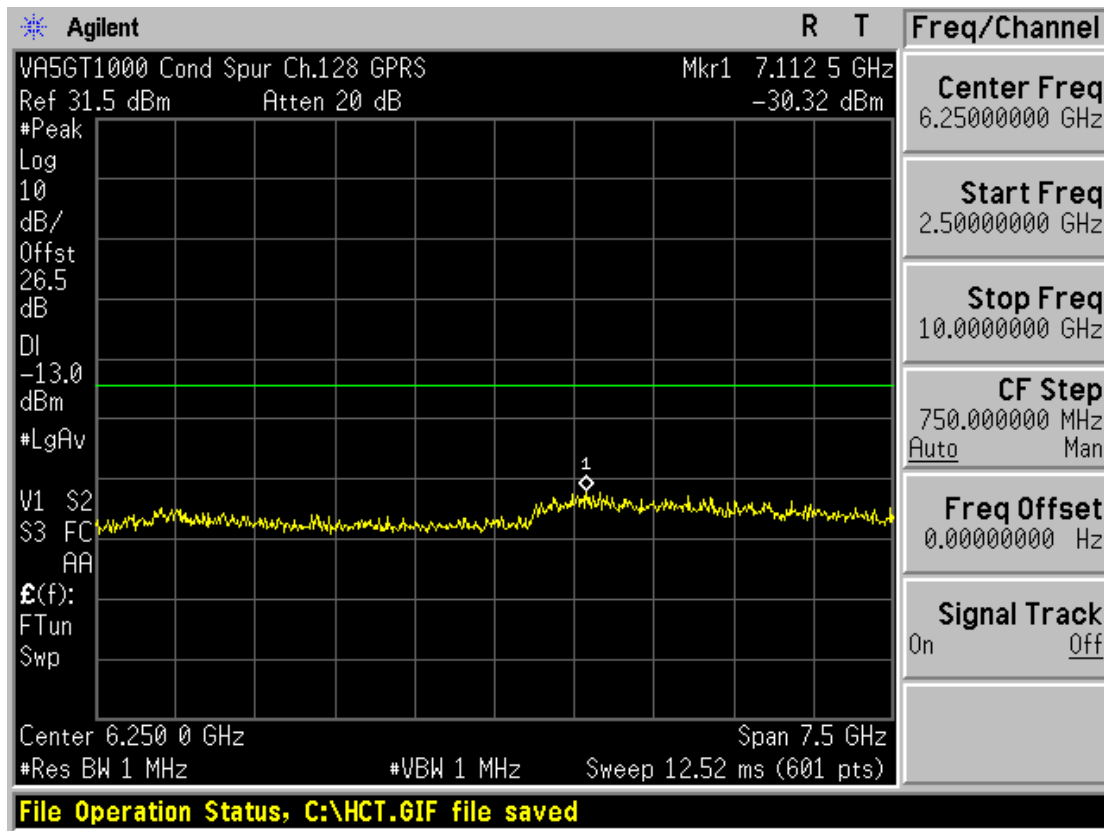

■ GSM850 MODE (190 CH.) Conducted Spurious Emissions1

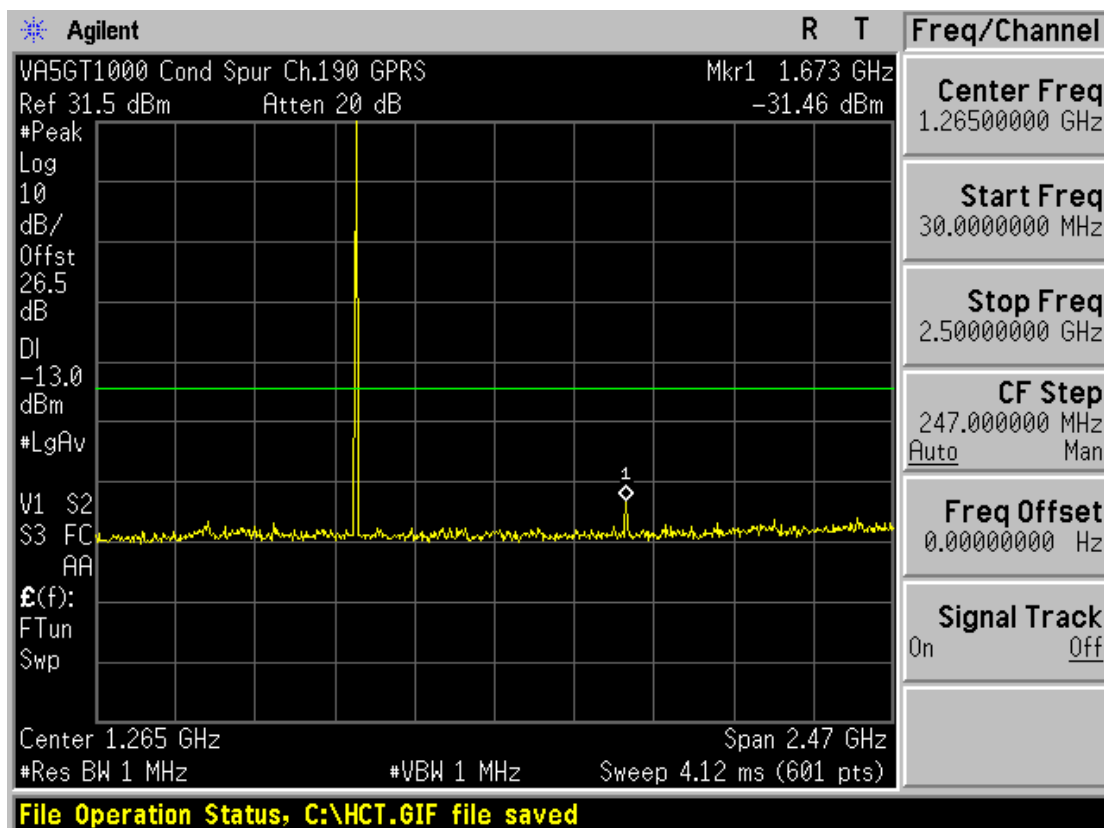

FCC CERTIFICATION REPORT			www.hct.co.kr
Test Report No. HCTR1107FR12	Date of Issue: July 11, 2011	EUT Type: Modem	FCC ID: VA5GT1000

■ GSM850 MODE (190 CH.) Conducted Spurious Emissions2

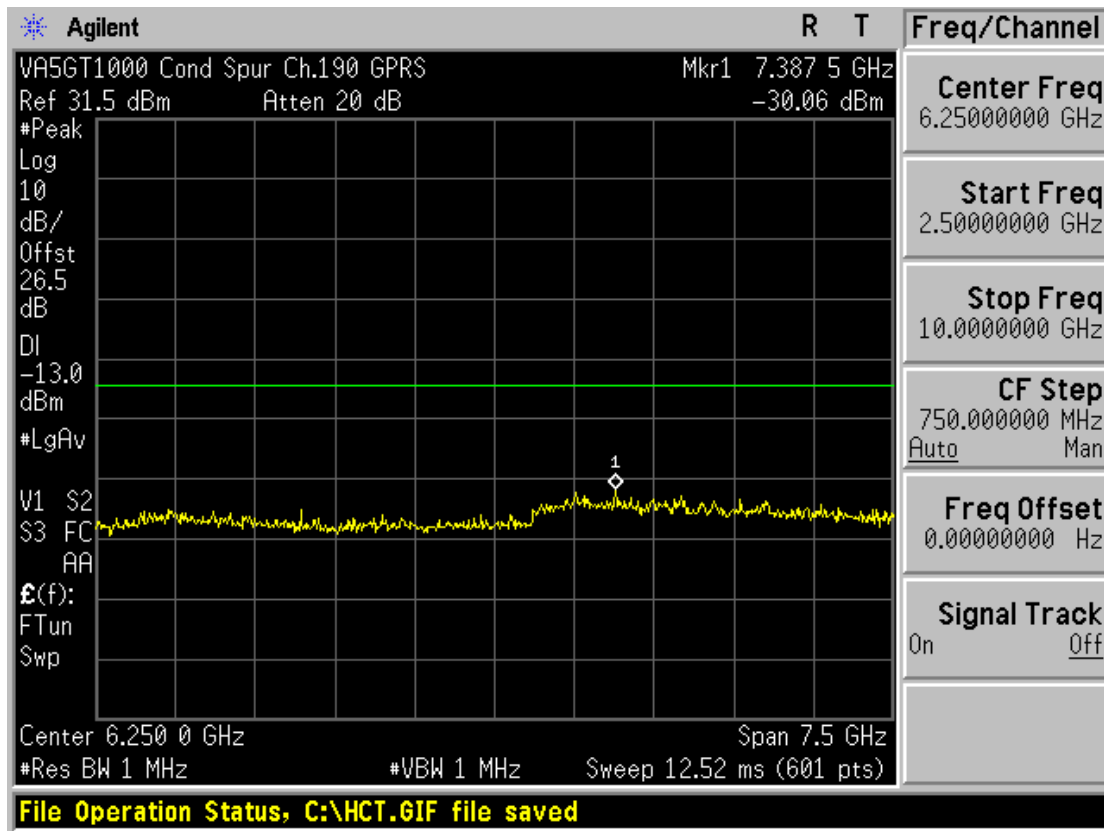

■ GSM850 MODE (251 CH.) Conducted Spurious Emissions1

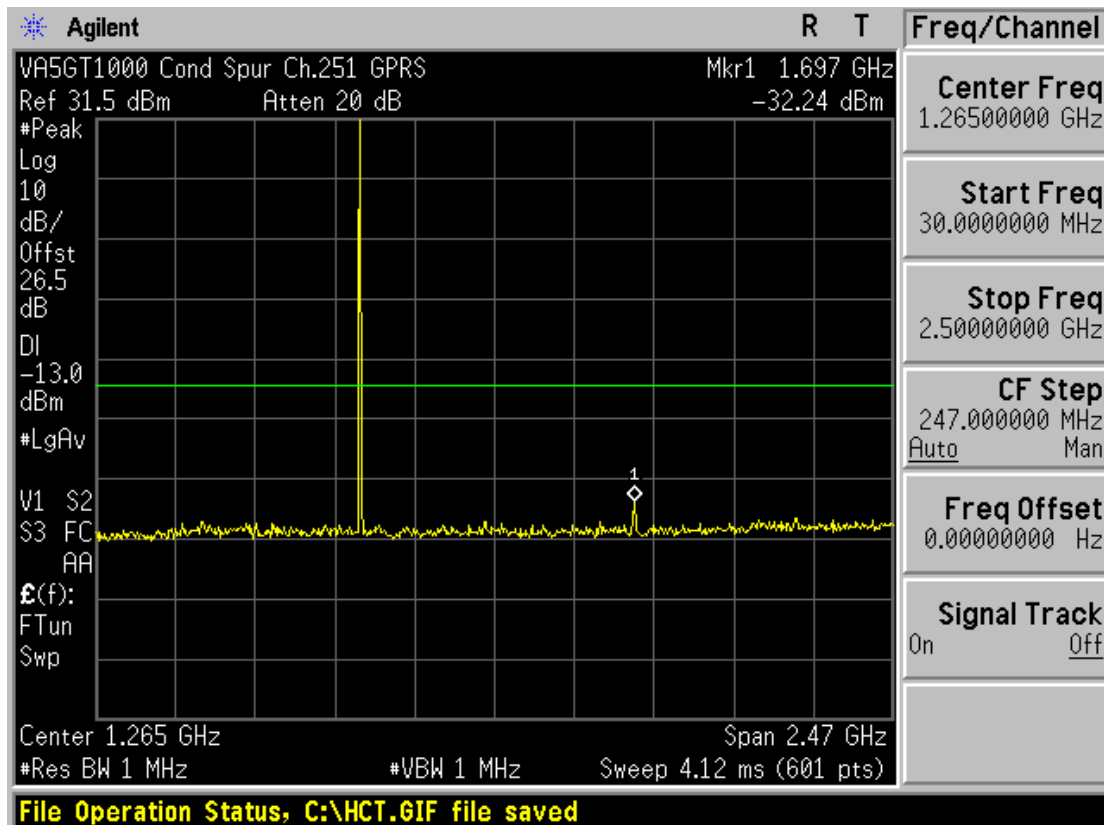

FCC CERTIFICATION REPORT			www.hct.co.kr
Test Report No. HCTR1107FR12	Date of Issue: July 11, 2011	EUT Type: Modem	FCC ID: VA5GT1000

■ GSM850 MODE (251 CH.) Conducted Spurious Emissions2

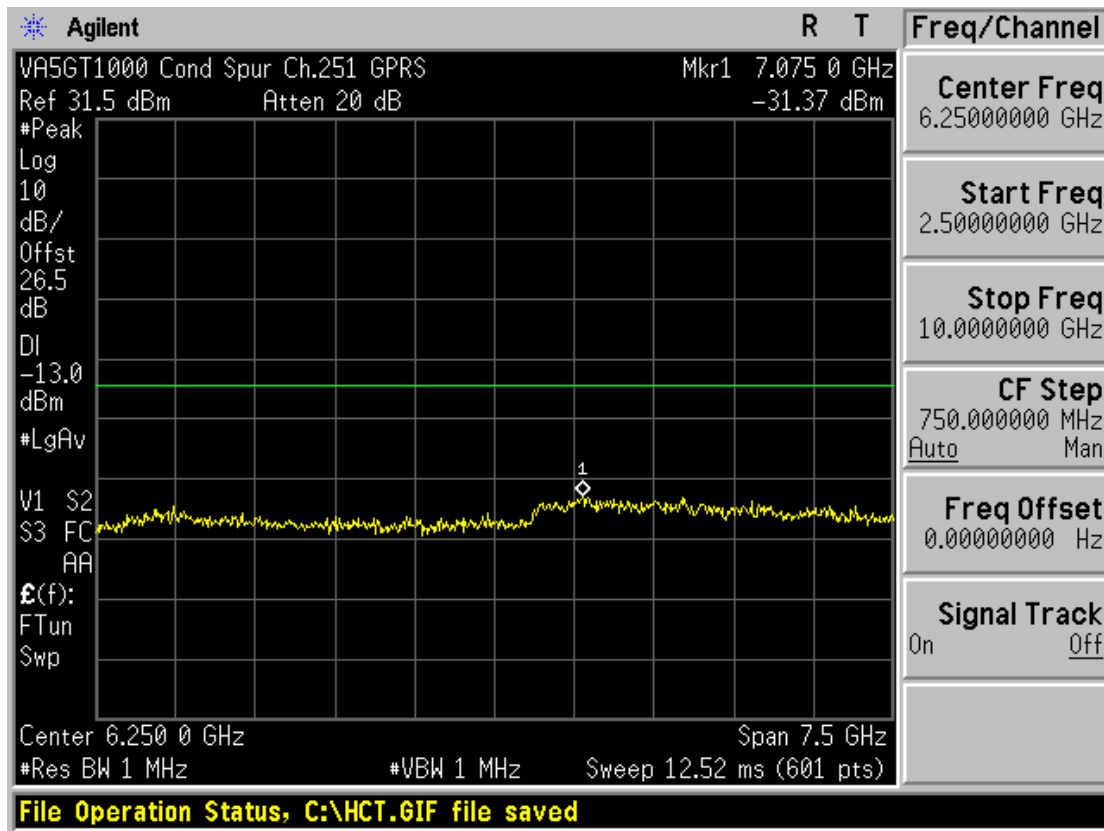

■ GSM1900 MODE (512 CH.) Conducted Spurious Emissions1

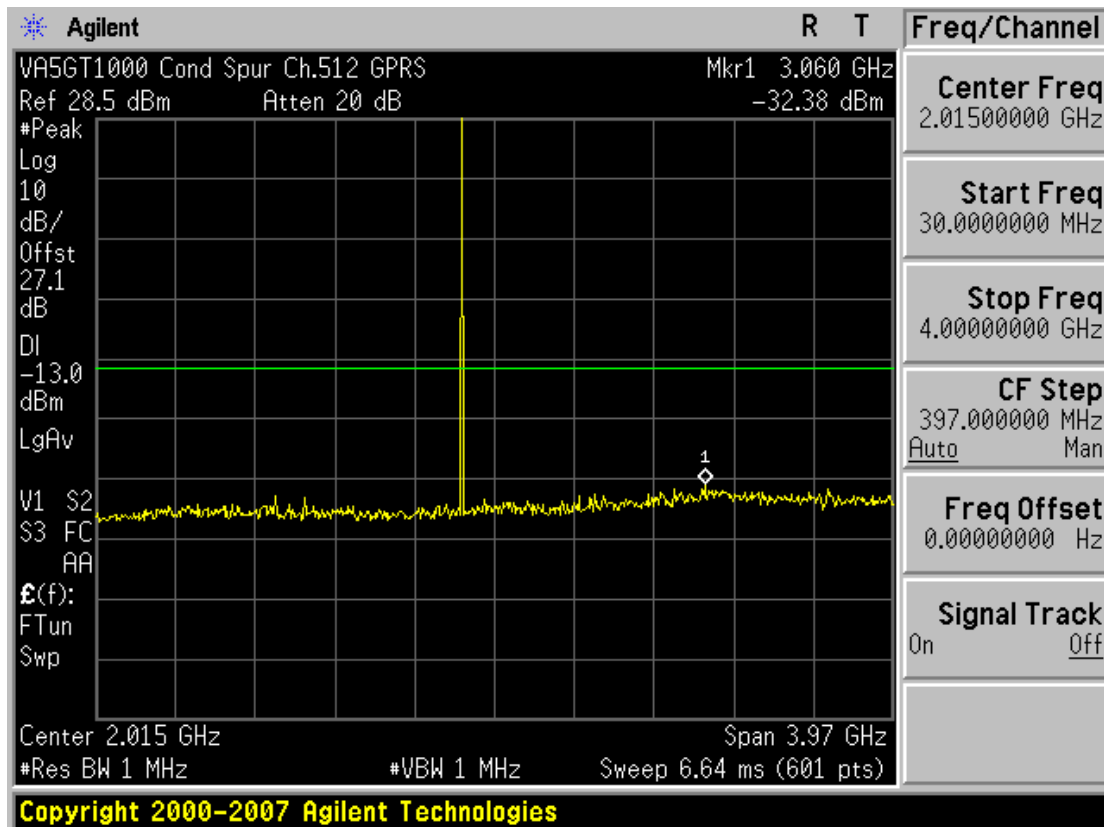

FCC CERTIFICATION REPORT			www.hct.co.kr
Test Report No. HCTR1107FR12	Date of Issue: July 11, 2011	EUT Type: Modem	FCC ID: VA5GT1000

■ GSM1900 MODE (512 CH.) Conducted Spurious Emissions2



■ GSM1900 MODE (661 CH) Conducted Spurious Emissions1

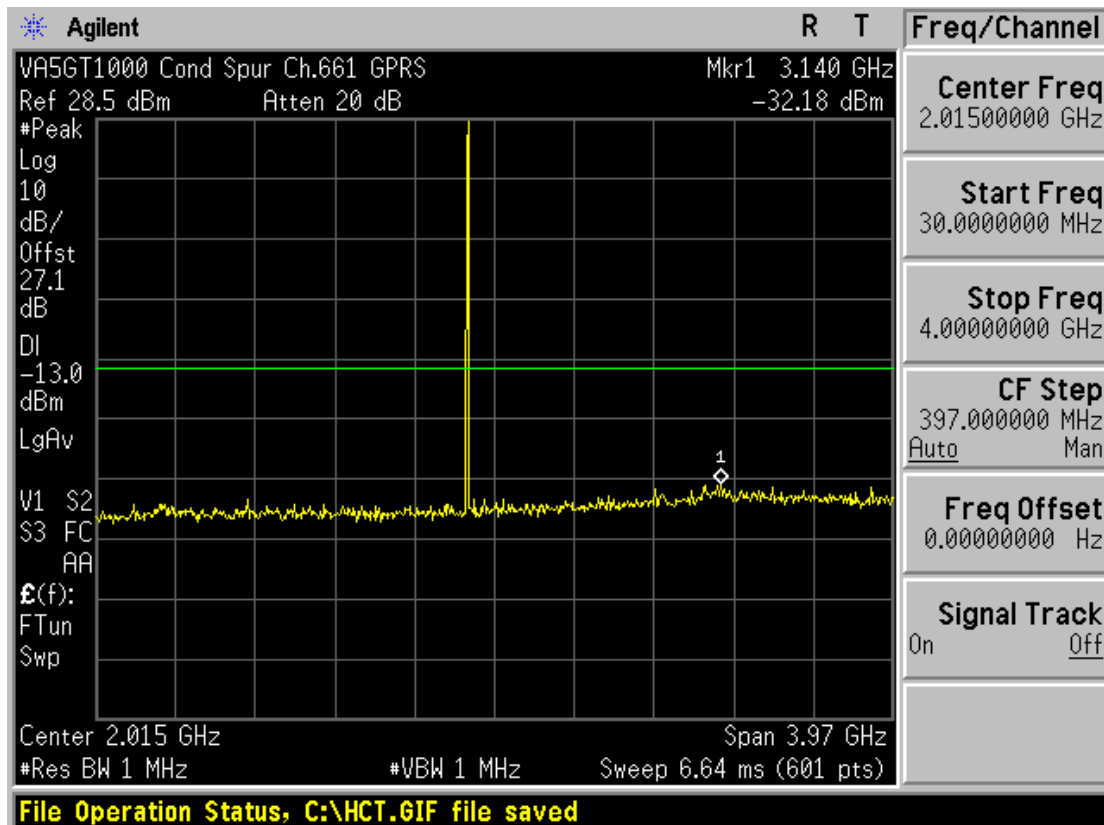

■ GSM1900 MODE (661 CH.) Conducted Spurious Emissions2

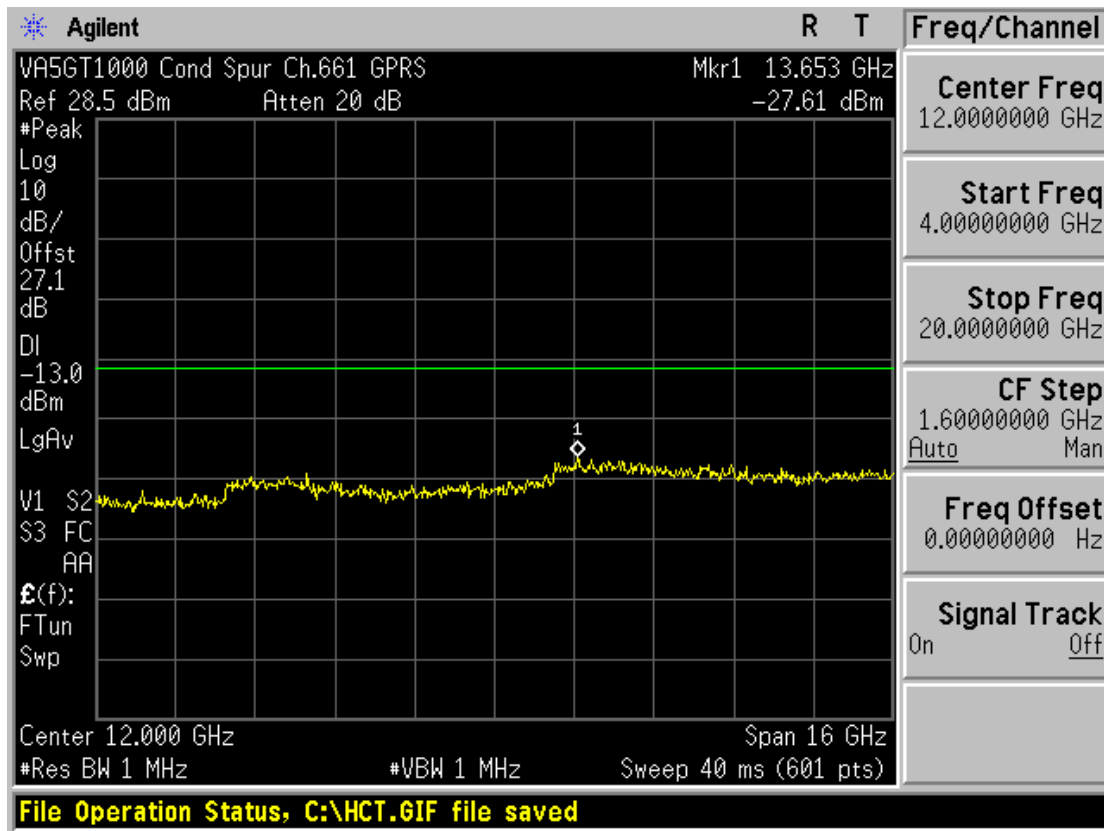

■ GSM1900 MODE (810 CH.) Conducted Spurious Emissions1

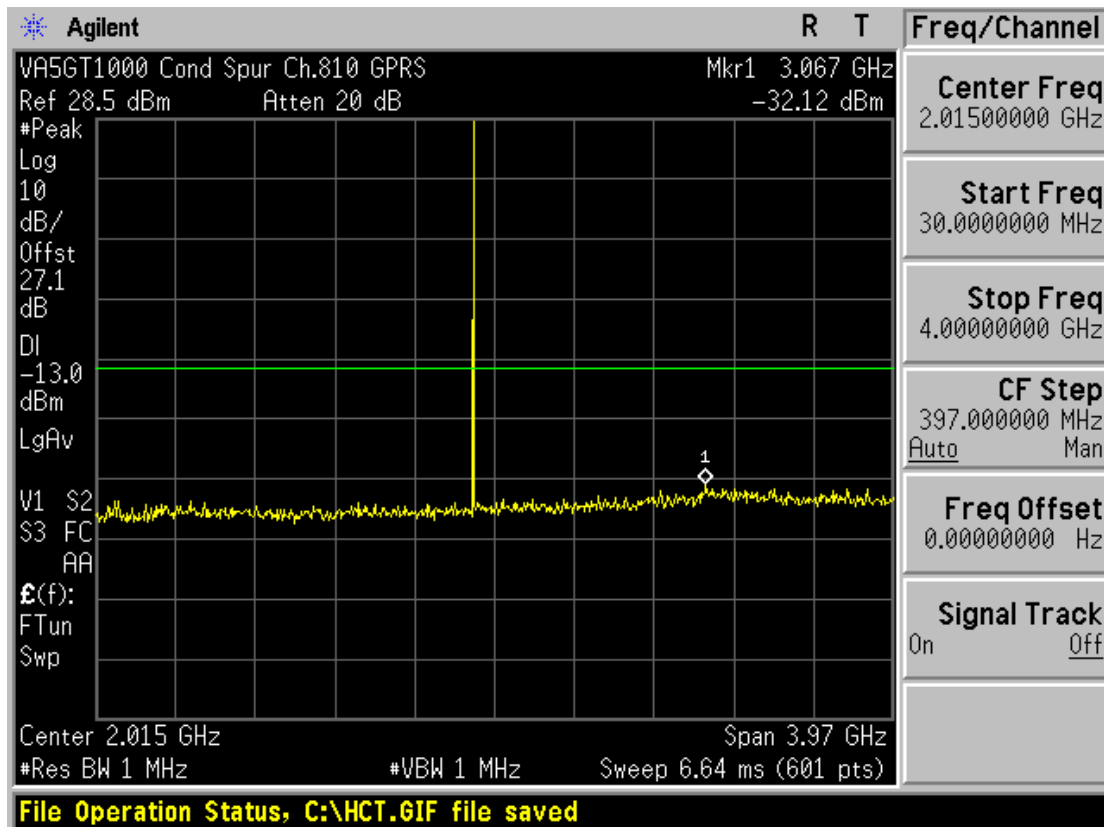

■ GSM1900 MODE (810 CH.) Conducted Spurious Emissions2

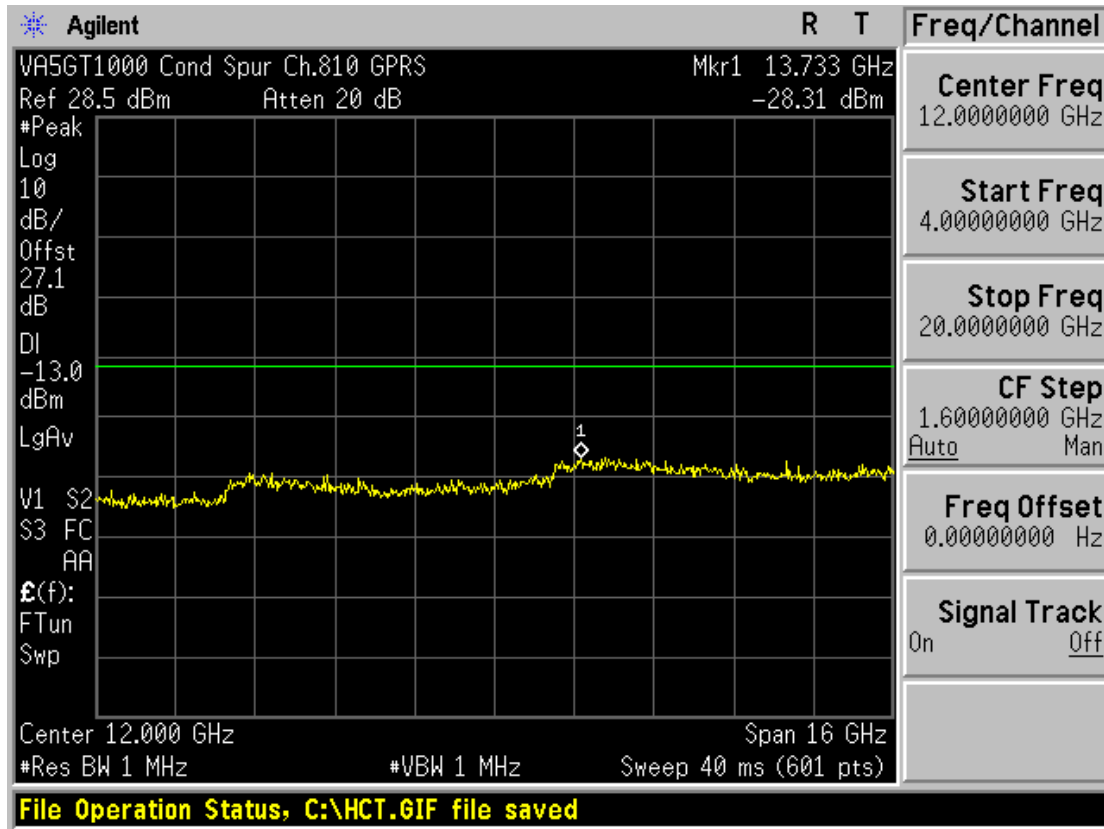

FCC CERTIFICATION REPORT			www.hct.co.kr
Test Report No. HCTR1107FR12	Date of Issue: July 11, 2011	EUT Type: Modem	FCC ID: VA5GT1000