



Valued Quality. Delivered.

## TEST REPORT

**Report No.: 16071735HKG-001**

**Toy State International Ltd.**

Application  
For  
Certification  
(Original Grant)  
**(FCC ID: V9Q-94424F27)**

Transmitter

Prepared and Checked by:

Approved by:

Signed On File  
Lok Chi Hang, Wil  
Assistant Engineer

---

Wong Kwok Yeung, Kenneth  
Senior Lead Engineer  
Date: September 13, 2016

- Intertek's standard Terms and Conditions can be obtained at our website <http://www.intertek.com/terms/>.
- The test report only allows to be revised within the retention period unless further standard or the requirement was noticed.
- This report is for the exclusive use of Intertek's Client and is provided pursuant to the agreement between Intertek and its Client. Intertek's responsibility and liability are limited to the terms and conditions of the agreement. Intertek assumes no liability to any party, other than to the Client in accordance with the agreement, for any loss, expense or damage occasioned by the use of this report. Only the Client is authorized to permit copying or distribution of this report and then only in its entirety. Any use of the Intertek name or one of its marks for the sale or advertisement of the tested material, product or service must first be approved in writing by Intertek. The observations and test results in this report are relevant only to the sample tested. This report by itself does not imply that the material, product, or service is or has ever been under an Intertek certification program.
- © 2016 Intertek

**Intertek Testing Services Hong Kong Ltd.**

2/F., Garment Centre, 576 Castle Peak Road, Kowloon, Hong Kong.

Tel: (852) 2173 8888 Fax: (852) 2785 5487 Website: [www.hk.intertek-ettsemko.com](http://www.hk.intertek-ettsemko.com)

## INTERTEK TESTING SERVICES

---

### GENERAL INFORMATION

Grantee:	Toy State International Ltd.
Grantee Address:	Unit 905, 9/F., West Wing, Tsim Sha Tsui Centre, 66 Mody Road, Tsim Sha Tsui East, Kowloon, Hong Kong.
Contact Person:	Cheung Yiuchung
Tel:	0755-3680 6243
Fax:	0755-2870 0487
e-mail:	N/A
Manufacturer:	Toy State International Limited
Manufacturer Address:	Unit 905, 9/F, West Wing, Tsim Sha Tsui Centre, 66 Mody Road, Tsim Sha Tsui East, Hong Kong.
Brand Name:	Nikko
Model:	94424
Type of EUT:	Transmitter
Description of EUT:	Nikko Hydro Thunder
Serial Number:	N/A
FCC ID:	V9Q-94424F27
Date of Sample Submitted:	July 23, 2016
Date of Test:	July 23, 2016 to August 11, 2016
Report No.:	16071735HKG-001
Report Date:	September 13, 2016
Environmental Conditions:	Temperature: +10 to 40°C Humidity: 10 to 90%

## INTERTEK TESTING SERVICES

---

### SUMMARY OF TEST RESULT

TEST SPECIFICATION	REFERENCE	RESULTS
Transmitter Field Strength	15.227	Pass

The equipment under test is found to be complying with the following standards:  
FCC Part 15, October 1, 2014 Edition

- Note: 1. The EUT uses a permanently attached antenna which, in accordance to section 15.203, is considered sufficient to comply with the provisions of this section.
2. Pursuant to FCC part 15 Section 15.215(c), the 20 dB bandwidth of the emission was contained within the frequency band designated (mentioned as above) which the EUT operated. The effects, if any, from frequency sweeping, frequency hopping, other modulation techniques and frequency stability over excepted variations in temperature and supply voltage were considered.

---

# INTERTEK TESTING SERVICES

---

## Table of Contents

1.0	<b><u>General Description</u></b> .....	1
1.1	Product Description .....	1
1.2	Related Submittal(s) Grants.....	1
1.3	Test Methodology .....	1
1.4	Test Facility .....	1
2.0	<b><u>System Test Configuration</u></b> .....	2
2.1	Justification.....	2
2.2	EUT Exercising Software.....	2
2.3	Special Accessories .....	2
2.4	Measurement Uncertainty.....	2
2.5	Support Equipment List and Description.....	2
3.0	<b><u>Emission Results</u></b> .....	3
3.1	Field Strength Calculation.....	3
3.2	Radiated Emission Configuration Photograph .....	4
3.3	Radiated Emission Data .....	4
4.0	<b><u>Equipment Photographs</u></b> .....	6
5.0	<b><u>Product Labelling</u></b> .....	6
6.0	<b><u>Technical Specifications</u></b> .....	6
7.0	<b><u>Instruction Manual</u></b> .....	6
8.0	<b><u>Miscellaneous Information</u></b> .....	7
8.1	Measured Bandwidth / Radiated Emission on the Bandedge .....	7
8.2	Discussion of Pulse Desensitization .....	8
8.3	Calculation of Average Factor.....	8
8.4	Emissions Test Procedures .....	8
9.0	<b><u>Equipment List</u></b> .....	11

## INTERTEK TESTING SERVICES

---

### 1.0 General Description

#### 1.1 Product Description

The Equipment Under Test (EUT) is a portable transmitter of a RC Boat operating at 27.145 MHz as dictated by a crystal. The EUT is powered by 2X1.5V AA batteries. The EUT has a left / right control lever and a forward / backward control lever.

After switching ON the EUT and the receiver of the RC Boat, activating the control levers on the EUT can control the receiver moving forward, backward, left and right directions.

Antenna Type: Integral, External antenna

For electronic filing, the brief circuit description is saved with filename: descri.pdf.

#### 1.2 Related Submittal(s) Grants

This is a single application for certification of a transmitter.

#### 1.3 Test Methodology

Radiated emission measurements was performed according to the procedures in ANSI C63.10 (2013). All radiated measurements were performed in an 3m Chamber. Preliminary scans were performed in the 3m Chamber only to determine worst case modes. All radiated tests were performed at an antenna to EUT distance of 3 meters, unless stated otherwise in the “**Justification Section**” of this Application.

#### 1.4 Test Facility

The 3m Chamber facility used to collect the radiated data is located at Workshop No. 3, G/F., World-Wide Industrial Centre, 43-47 Shan Mei Street, Fo Tan, Sha Tin, N.T., Hong Kong. This test facility and site measurement data have been placed on file with the FCC.

## INTERTEK TESTING SERVICES

---

### 2.0 **System Test Configuration**

#### 2.1 Justification

The system was configured for testing in a typical fashion (as a customer would normally use it), and in the confines as outlined in ANSI C63.10 (2013).

The device was powered by new 2 x 1.5V AA batteries.

For maximizing emissions below 30 MHz, the EUT was rotated through 360°, the centre of the loop antenna was placed 1 meter above the ground, and the antenna polarization was changed. For maximizing emission at and above 30 MHz, the EUT was rotated through 360°, the antenna height was varied from 1 meter to 4 meters above the ground plane, and the antenna polarization was changed. This step by step procedure for maximizing emissions led to the data report in Exhibit 3.0.

The unit was operated standalone and placed in the center of the turntable.

The equipment under test (EUT) was configured for testing in a typical fashion (as a customer would normally use it). The EUT was mounted to a plastic stand if necessary and placed on the wooden turntable, which enabled the engineer to maximize emissions through its placement in the three orthogonal axes.

#### 2.2 EUT Exercising Software

There was no special software to exercise the device. Once the unit is powered up, it transmits the RF signal continuously.

#### 2.3 Special Accessories

There are no special accessories necessary for compliance of this product.

#### 2.4 Measurement Uncertainty

When determining of the test conclusion, the Measurement Uncertainty of test has been considered.

#### 2.5 Support Equipment List and Description

N/A.

## INTERTEK TESTING SERVICES

---

### 3.0 Emission Results

Data is included of the worst case configuration (the configuration which resulted in the highest emission levels). A sample calculation, configuration photographs and data tables of the emissions are included.

#### 3.1 Field Strength Calculation

The field strength is calculated by adding the Antenna Factor and Cable Factor, and subtracting the Amplifier Gain (if any), Average Factor (optional) from the measured reading. The basic equation with a sample calculation is as follows:

$$FS = RA + AF + CF - AG - AV$$

where

- FS = Field Strength in dB $\mu$ V/m
- RA = Receiver Amplitude (including preamplifier) in dB $\mu$ V
- CF = Cable Attenuation Factor in dB
- AF = Antenna Factor in dB
- AG = Amplifier Gain in dB
- AV = Average Factor in dB

In the following table(s), the reading shown on the data table reflects the preamplifier gain. An example for the calculations in the following table is as follows:

$$FS = RR + LF$$

where

- FS = Field Strength in dB $\mu$ V/m
- RR = RA - AG - AV in dB $\mu$ V
- LF = CF + AF in dB

Assume a receiver reading of 52.0 dB $\mu$ V is obtained. The antenna factor of 7.4 dB and cable factor of 1.6 dB are added. The amplifier gain of 29 dB and average factor of 5 dB are subtracted, giving a field strength of 27 dB $\mu$ V/m. This value in dB $\mu$ V/m was converted to its corresponding level in  $\mu$ V/m.

$$\begin{aligned} RA &= 52.0 \text{ dB}\mu\text{V/m} \\ AF &= 7.4 \text{ dB} & RR &= 18.0 \text{ dB}\mu\text{V} \\ CF &= 1.6 \text{ dB} & LF &= 9.0 \text{ dB} \\ AG &= 29.0 \text{ dB} \\ AV &= 5.0 \text{ dB} \\ FS &= RR + LF \\ FS &= 18 + 9 = 27 \text{ dB}\mu\text{V/m} \end{aligned}$$

$$\text{Level in } \mu\text{V/m} = \text{Common Antilogarithm } [(27 \text{ dB}\mu\text{V/m})/20] = 22.4 \mu\text{V/m}$$

## INTERTEK TESTING SERVICES

---

### 3.2 Radiated Emission Configuration Photograph

The worst case in radiated emission was found at 27.145 MHz

For electronic filing, the worst case radiated emission configuration photographs are saved with filename: radiated photos.pdf.

### 3.3 Radiated Emission Data

The data on the following page lists the significant emission frequencies, the limit and the margin of compliance. Numbers with a minus sign are below the limit.

Judgment: Passed by 6.3 dB



## INTERTEK TESTING SERVICES

Applicant: Toy State International Ltd.

Date of Test: August 11, 2016

Model: 94424

Worst-Case Operating Mode: Transmitting

Table 1  
**Radiated Emissions**  
**Pursuant to FCC Part 15 Section 15.227 Requirement**

Polarization	Frequency (MHz)	Reading (dB $\mu$ V)	Pre-Amp (dB)	Antenna Factor (dB)	Average Factor (dB)	Net at 3m (dB $\mu$ V/m)	Limit at 3m (dB $\mu$ V/m)	Margin (dB)
V	27.145	74.3	16	15.4	0.0	73.7	80.0	-6.3
V	54.282	35.2	16	11.0	-	30.2	40.0	-9.8
V	81.420	37.6	16	7.0	-	28.6	40.0	-11.4
<b>V</b>	<b>108.590</b>	<b>37.8</b>	<b>16</b>	<b>14.0</b>	-	<b>35.8</b>	<b>43.5</b>	<b>-7.7</b>
<b>V</b>	<b>112.717</b>	<b>27.8</b>	<b>16</b>	<b>14.0</b>	-	<b>25.8</b>	<b>43.5</b>	<b>-17.7</b>
<b>V</b>	<b>135.727</b>	<b>38.4</b>	<b>16</b>	<b>14.0</b>	-	<b>36.4</b>	<b>43.5</b>	<b>-7.1</b>
<b>V</b>	<b>162.865</b>	<b>34.9</b>	<b>16</b>	<b>16.0</b>	-	<b>34.9</b>	<b>43.5</b>	<b>-8.6</b>
V	190.035	31.6	16	16.0	-	31.6	43.5	-11.9
V	217.172	36.5	16	17.0	-	37.5	46.0	-8.5
<b>V</b>	<b>244.310</b>	<b>34.4</b>	<b>16</b>	<b>20.0</b>	-	<b>38.4</b>	<b>46.0</b>	<b>-7.6</b>
<b>V</b>	<b>271.447</b>	<b>31.9</b>	<b>16</b>	<b>22.0</b>	-	<b>37.9</b>	<b>46.0</b>	<b>-8.1</b>

NOTES: 1. Peak Detector Data unless otherwise stated.

2. All measurements were made at 3 meters. Harmonic emissions not detected at the 3-meter distances were measured at 0.3-meter and an inverse proportional extrapolation was performed to compare the signal level to the 3-meter limit. No other harmonic emissions than those reported were detected at a test distance of 0.3-meter.

3. Negative sign in the column shows value below limit.

4. Loop antenna is used for the emissions below 30MHz.

5. Emission (the row indicated by **bold italic**) within the restricted band meets the requirement of FCC Part 15 Section 15.205.

6. Measurement Uncertainty is  $\pm 5.3$ dB at a level of confidence of 95%.

## INTERTEK TESTING SERVICES

---

### 4.0 **Equipment Photographs**

For electronic filing, the photographs are saved with filename: external photos.pdf and internal photos.pdf.

### 5.0 **Product Labelling**

For electronics filing, the FCC ID label artwork and the label location are saved with filename: label.pdf.

### 6.0 **Technical Specifications**

For electronic filing, the block diagram and schematic of the tested EUT are saved with filename: block.pdf and circuit.pdf respectively.

### 7.0 **Instruction Manual**

For electronic filing, a preliminary copy of the Instruction Manual is saved with filename: manual.pdf.

This manual will be provided to the end-user with each unit sold/leased in the United States.

# INTERTEK TESTING SERVICES

## 8.0 Miscellaneous Information

The miscellaneous information includes details of the test procedure.

### 8.1 Measured Bandwidth

The plot shows the fundamental emission is confined in the specified band. And it also shows that the emission is at least -36.33 dB below the carrier level at the band edge (26.96 and 27.28 MHz). It meets the requirement of Section 15.227(b).

Pursuant to FCC Part 15 Section 15.215(c), the 20dB bandwidth of the emission was contained within the frequency band designed (mentioned as above) which the EUT operated. The effects, if any, from frequency sweeping, frequency hopping, other modulation techniques and frequency stability over expected variations in temperature and supply voltage were considered.

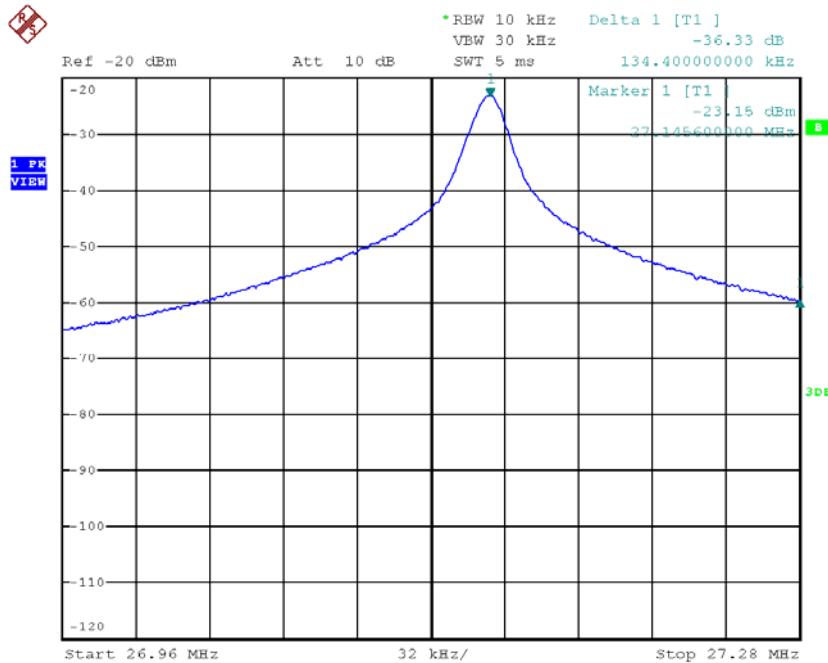

## INTERTEK TESTING SERVICES

---

### 8.2 Discussion of Pulse Desensitization

Pulse desensitivity is not applicable for this device. Since the transmitter transmits the RF signal continuously.

### 8.3 Calculation of Average Factor

It is not necessary to apply average factor as the measured (peak) data has been complied with average limit of the radiated emission.

### 8.4 Emissions Test Procedures

The following is a description of the test procedure used by Intertek Testing Services Hong Kong Ltd. in the measurements of transmitter operating under the Part 15, Subpart C rules.

The transmitting equipment under test (EUT) is placed on a wooden turntable which is four feet in diameter and approximately 0.8m in height above the ground plane for emission measurement at or below 1GHz and 1.5m in height above the ground plane for emission measurement above 1GHz. During the radiated emissions test, the turntable is rotated and any cables leaving the EUT are manipulated to find the configuration resulting in maximum emissions. The EUT is adjusted through all three orthogonal axis to obtain maximum emission levels. The antenna height and polarization are also varied during the testing to search for maximum signal levels. The height of the antenna is varied from one to four meters.

Detector function for radiated emissions is in peak mode. Average readings, when required, are taken by measuring the duty cycle of the equipment under test and subtracting the corresponding amount in dB from the measured peak readings. A detailed description for the calculation of the average factor can be found in Exhibit 8.3.

The frequency range scanned is from the lowest radio frequency signal generated in the device which is greater than 9 kHz to the tenth harmonic of the highest fundamental frequency or 40 GHz, whichever is lower.

## INTERTEK TESTING SERVICES

---

### 8.4 Emissions Test Procedures (cont'd)

The EUT is warmed up for 15 minutes prior to the test.

AC power to the unit is varied from 85% to 115% nominal and variation in the fundamental emission field strength is recorded. If battery powered, a new, fully charged battery is used.

Conducted measurements were made as described in ANSI C63.10 (2013).

The IF bandwidth used for measurement of radiated signal strength was 100 kHz or greater when frequency is below 1000 MHz. Where pulsed transmissions of short enough pulse duration warrant, a greater bandwidth is selected according to the recommendations of Hewlett Packard Application Note 150-2. A discussion of whether pulse desensitivity is applicable to this unit is included in this report (See Exhibit 8.1). Above 1000 MHz, a resolution bandwidth of 1 MHz is used.

Transmitter measurements are normally conducted at a measurement distance of three meters. However, to assure low enough noise floor in the forbidden bands and above 1 GHz, signals are acquired at a distance of one meter or less. All measurements are extrapolated to three meters using inverse scaling, unless otherwise reported. Measurements taken at a closer distance are so marked.

# INTERTEK TESTING SERVICES

## 8.4.1 Radiated Emission Test Setup

The figure below shows the test setup, which is utilized to make these measurements.

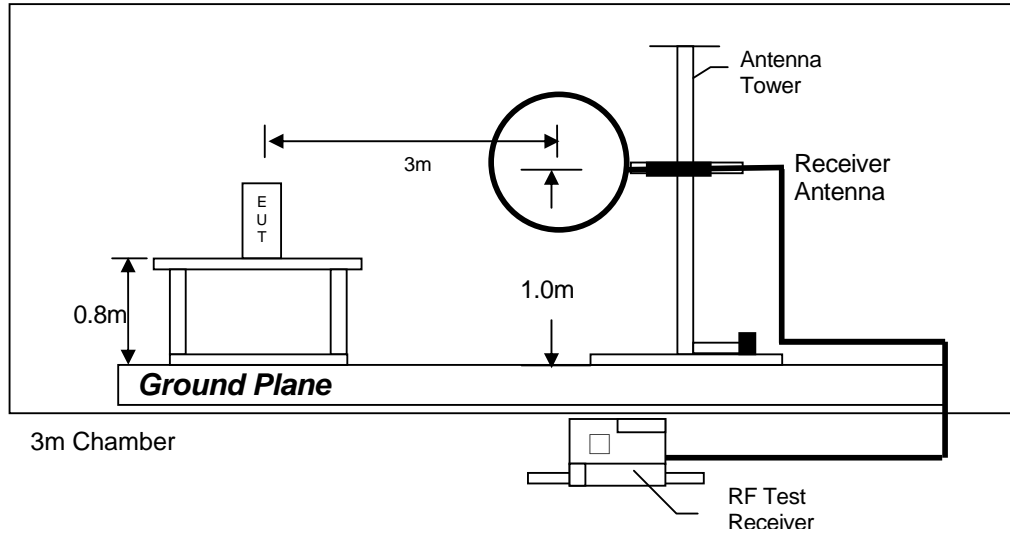

Test setup of radiated emissions up to 30MHz

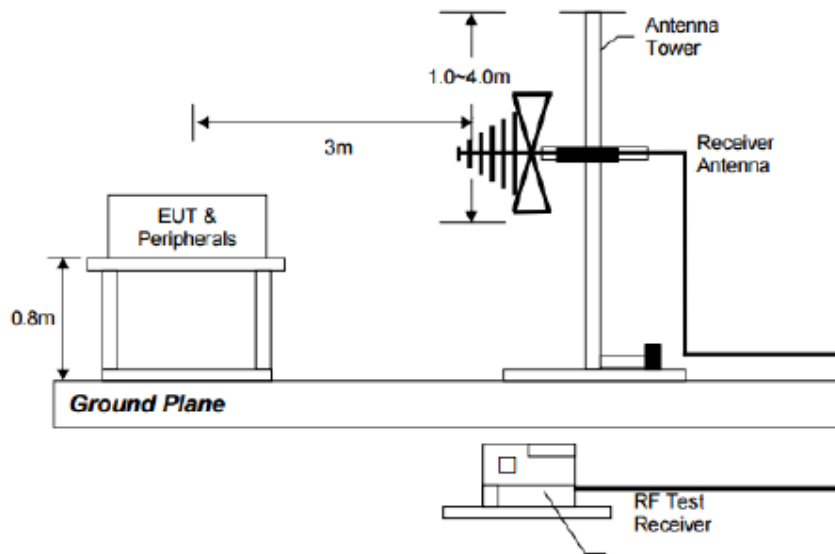

Test setup of radiated emissions from 30MHz to 1GHz

## INTERTEK TESTING SERVICES

---

### 9.0 Equipment List

#### 1) Radiated Emissions Test

Equipment	EMI Test Receiver	Biconical Antenna
Registration No.	EW-3156	EW-0571
Manufacturer	R&S	EMCO
Model No.	ESR26	3104C
Calibration Date	Nov. 03, 2015	Jun. 23, 2015
Calibration Due Date	Nov. 03, 2016	Dec. 23, 2016

Equipment	Log Periodic Antenna
Registration No.	EW-0572
Manufacturer	EMCO
Model No.	3148
Calibration Date	May. 21, 2015
Calibration Due Date	Nov. 21, 2016

Equipment	Active Loop H-field
Registration No.	EW-0191
Manufacturer	ELETROMETRIC
Model No.	EM-6876
Calibration Date	Mar. 11, 2016
Calibration Due Date	Sep. 11, 2017

#### 2) Bandedge Measurement

Equipment	Spectrum Analyzer
Registration No.	EW-2249
Manufacturer	R&S
Model No.	FSP30
Calibration Date	Nov. 27, 2015
Calibration Due Date	Nov. 27, 2016

END OF TEST REPORT